

relief from this Court to resolve this dispute and be compensated for the injury caused by Defendants' unlawful business practices.

PARTIES

4. Plaintiff is now, and at all times relevant herein was, a California limited liability company, having a principal place of business in Hacienda Heights, California.

5. Plaintiff is informed and believes, and on that basis alleges, that Defendant DreamBuilder Toy LLC is, and at all times relevant herein was, an Ohio limited liability company, having a principal place of business at 4727 Vista Ridge Drive, Dublin, Ohio 43017.

6. The true names and capacities, whether individual, corporate, associate, or otherwise, of Defendants DOES 1 through 10, inclusive (individual a "Doe Defendant" and collectively, "Doe Defendants"), are unknown to Plaintiff at this time, and Plaintiff, therefore, sues Doe Defendants by such fictitious names. Plaintiff will ask leave of Court to amend this Complaint when the same shall have been ascertained. Plaintiff is informed and believes, and based thereon alleges that each Doe Defendant was responsible intentionally, or in some other actionable manner for the events and happenings referred to herein, which proximately caused injury and damage to Plaintiff, as hereafter alleged. Any reference to Defendants shall refer to each named Defendant and all Doe Defendants, and to each of them. Any reference to a particular Defendant shall refer to the named Defendant only.

7. Plaintiff is informed and believes, and on that basis alleges, that Defendants are responsible for their acts and for their conduct, which are the true legal causes of the damages herein alleged.

JURISDICTION AND VENUE

8. This Court has jurisdiction over the subject matter of this action under 28 U.S.C. §§ 1331 (federal question), 1338(a) (patent infringement), and 1332 (diversity of citizenship).

9. Personal jurisdiction as to these Defendants is conferred on this Court because Defendants have purposefully availed themselves of the benefits and privileges of transacting business within the State of Ohio. In particular, Defendants have their principal place of business in Dublin, Ohio and are, therefore, domiciled in the State of Ohio.

10. This Court also has personal jurisdiction over Defendants because Defendants have caused injury to Plaintiff within the State of Ohio and within this judicial district. Defendants have committed and continue to commit unlawful acts expressly aimed at Plaintiff in Ohio, knowing that the harm resulting from this conduct will be suffered by Plaintiff in Ohio.

11. Venue is proper in the Southern District of Ohio under 28 U.S.C. § 1400(a) and (b). Defendants reside in this district and, therefore, have a regular and established place of business in this district at 4727 Vista Ridge Drive, Dublin, Ohio 43017. Defendants have also committed acts of infringement of the Patents in this district by offering for sale the Infringing Products.

FACTUAL BACKGROUND

12. On October 6, 2015, a design patent application for “magnetic brick” was filed with the United States Patent and Trademark Office (USPTO) and on April 25, 2017, was duly and lawfully issued by the USPTO as D784,938. On October 6, 2015, another design patent application for “single magnetic brick” was filed with the USPTO and on June 13, 2017, was duly and lawfully issued by the USPTO as D789,312. True and correct copies of the Patents are attached hereto as **EXHIBIT A.**

13. Plaintiff is the true owner of all rights, title, and interest in the Patents that encompasses the magnetic brick designs. Plaintiff possesses the right to sue for and obtain equitable relief and damages for infringement of the Patents.

14. The success and novelty of the Patents prompted third parties, including Defendants, to manufacture and/or distribute blatant counterfeits of Plaintiff’s innovative design

to compete with and infringe the Patents. See **EXHIBIT B** for examples of Defendants’ infringement of the Patents.

15. Defendants have directly infringed and continue to directly infringe the Patent by making, using, selling, and offering for sale in the United States, and/or importing into the United States the Infringing Products (exemplified in **EXHIBIT B**), embodying the invention defined by one or more claims of the Patent, without authority or license from Plaintiff. More particularly, Defendants have infringed and continue to infringe the Patents because Infringing Products are substantially similar to the designs protected by the Patents.

16. Plaintiff has complied with the marking and notice requirements of 35 U.S.C. § 287.

17. A comparison of the numerous substantially similar, if not nearly identical, ornamental features of the Infringing Products are apparent with reference to the below charts:

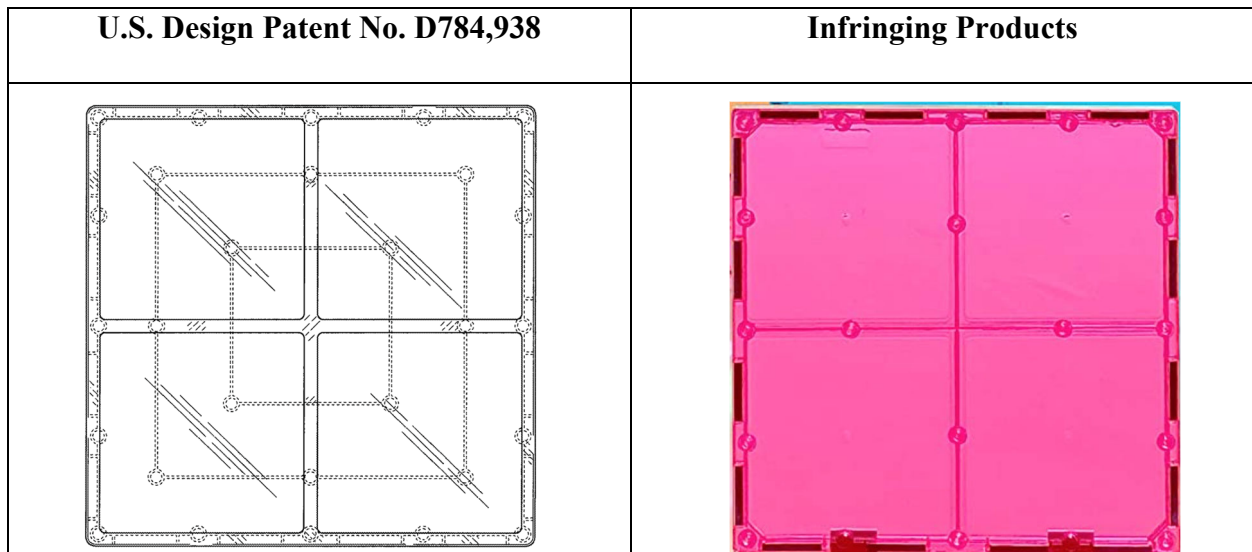

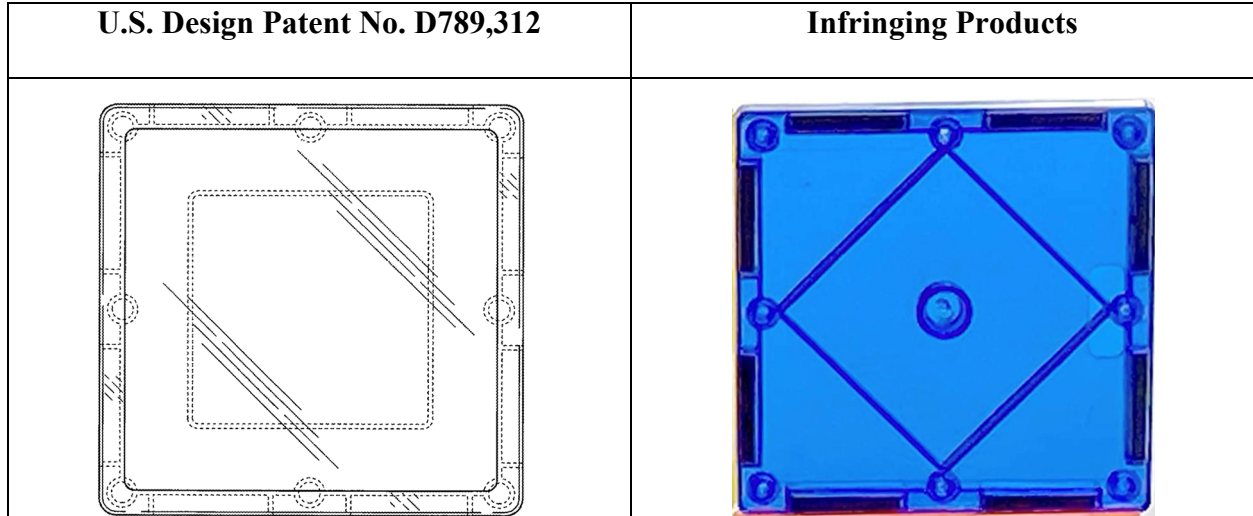

18. To address Defendants' infringement, Plaintiff filed a takedown notice against Defendants' Infringing Products on Amazon.com. Because these notices were unsuccessful, Plaintiff was left with no choice but to resolve this dispute in a formalized proceeding.

19. Defendants' Infringing Products were, and still are manufactured, distributed, and/or offered for sale using a substantially similar design, characteristic, and size as Plaintiff's Patents.

20. Plaintiff is informed and believes, and on that basis alleges, that Defendants were aware of Plaintiff's rights before they began their infringing activities. Defendants' use and infringement is therefore willful.

FIRST CLAIM FOR RELIEF

Design Patent Infringement – 35 U.S.C. § 271

21. Plaintiff hereby restates and realleges the allegations set forth in paragraphs 1 through 20 above and incorporates them by reference.

22. Plaintiff is the sole owner of the entire right, title, and interest in the Patents, which were duly and lawfully issued by the USPTO.

23. Defendants have, and continue to, knowingly, intentionally, and willfully infringe

the Patents by selling, offering for sale, and/or importing the Infringing Products that would appear to an ordinary observer to be substantially similar to the claims of the Patents.

24. Defendants undertook their acts of infringement of the Patents without permission or license.

25. Plaintiff is informed and believes, and on that basis alleges, that Defendants had actual knowledge of Plaintiff's right in the designs claimed in the Patents. Defendants' actions constitute reckless disregard for Plaintiff's patent rights or otherwise willful and intentional infringement of the Patents.

26. As a direct and proximate result of Defendants' acts of infringement, Defendants have derived and received gains, profits, and advantages in an amount that is not presently known to Plaintiff.

27. Pursuant to 35 U.S.C. § 284, Plaintiff is entitled to damages for Defendants' infringing acts and treble damages together with interest and cost as fixed by this Court.

28. Pursuant to 35 U.S.C. § 285, Plaintiff is entitled to reasonable attorneys' fees for the necessity of bringing this claim.

29. Pursuant to 35 U.S.C. § 289, Plaintiff is entitled to recover Defendants' total profits from Defendants' infringement.

30. Due to Defendants' infringing acts, Plaintiff has suffered great and irreparable injury, for which Plaintiff has no adequate remedy at law.

31. Defendants will continue to infringe Plaintiff's patent rights and Plaintiff will continue to suffer irreparable harm unless enjoined by this Court.

SECOND CLAIM FOR RELIEF

Unfair Competition – Cal. Bus. & Prof. Code § 17200 *et seq.*

32. Plaintiff hereby restates and realleges the allegations set forth in paragraphs 1 through 31 above and incorporates them by reference.

33. California Business and Professions Code, Section 17200 states, in pertinent part: “...unfair competition shall mean and include any unlawful, unfair or fraudulent business act or practice and unfair, deceptive, untrue or misleading advertising and any act prohibited by Chapter 1 (commencing with Section 17500) of Part 3 of Division 7 of the Business and Professions Code.”

34. At all times mentioned herein, Defendants have engaged in “unfair” business practices. Defendants have maliciously disrupted Plaintiff’s business by offering for sale and selling the Infringing Products, which infringe Plaintiff’s Patents. Such acts by Defendants are unlawful.

35. As a direct and proximate result of Defendants’ wrongful acts, Plaintiff has been, is now, and will be irreparably injured and damaged by Defendants’ aforementioned acts. Unless Defendants are enjoined by this Court, Plaintiff will suffer further harm to its business. This harm constitutes an injury for which Plaintiff has no adequate remedy at law.

36. Defendants have acted with the intent to disrupt Plaintiff’s business and thus, its acts are willful and intentional.

37. Defendants should be required to restore to Plaintiff its lost revenue as a result of Defendants’ unlawful business acts or to provide Plaintiff with any other restitutionary relief as the Court deems appropriate.

PRAYER FOR RELIEF

WHEREFORE, Plaintiff respectfully prays for judgment against Defendants as follows:

A. Entry of a judgment that Defendants have infringed U.S. Patent No. D784,938;

- B. Entry of a judgment that Defendants have infringed U.S. Patent No. D789,312;
- C. Entry of a judgment that Defendants willfully and deliberately infringed Plaintiff's Patents;
- D. An order preliminarily and permanently restraining and enjoining Defendants, its officers, agents, attorneys and employees, and those acting in privity or concert with Defendants, from engaging in the manufacture, use, offer for sale or sale within the United States, or importation into the United States, of the Infringing Products until after the expiration date of the Patents;
- E. An order requiring Defendants to deliver and be impounded during the pendency of this action all material in Defendants' possession, custody, or control that includes or incorporates products that infringe Plaintiff's patent rights, including but not limited to, any products, containers, packages, labels, and advertisements in their possession or under their control utilizing Plaintiff's Patents, or any simulation, reproduction, counterfeit, copy, or colorable imitation thereof;
- F. An order of an independent accounting of all of Defendants' financial records relating to their infringing activities in order to determine the sums of money owed to Plaintiff;
- G. An order requiring Defendants to pay to Plaintiff all damages or other monetary relief, including but not limited to all gains, profits, and advantages derived by Defendants as a result of Defendants' infringement of the Patents;
- H. An order requiring Defendants to pay to Plaintiff treble damages and/or exemplary damages because of Defendants' willful conduct pursuant to 35 U.S.C. § 284;
- I. Costs and reasonable attorneys' fees relating to this action pursuant to 35 U.S.C. § 285;
- J. Pre-judgment and post-judgment interest and costs in bringing this action against

Defendants; and

K. Such other and further relief as the Court may deem just and proper.

DEMAND FOR A JURY TRIAL

Pursuant to Rule 38(b) of the Federal Rules of Civil Procedure, Plaintiff requests a jury trial of all issues that may be tried to a jury in this action.

RESPECTFULLY SUBMITTED this 23rd day of July, 2022.

/s/ Jeffrey C. Norris

Jeffrey C. Norris (OH Bar 0066986)
F. Michael Speed, Jr. (OH Bar 0067541)
STANDLEY LAW GROUP LLP
6300 Riverside Drive
Dublin, Ohio 43017
Phone: 614.792.5555
Facsimile: 614.792.5536
jnorris@standleyllp.com
mspeed@standleyllp.com
litigation@standleyllp.com

Omid E. Khalifeh*, SBN 267340
Lara A. Petersen*, SBN 318475
OMNI LEGAL GROUP
2029 Century Park E, Suite 438
Los Angeles, California 90067
Phone: 310.276.6664
Facsimile: 310.305.1550
omid@omnilg.com
lara@omnilg.com

Attorneys for Plaintiff,
LALTITUDE LLC

**Pro Hac Vice pending*