

EXHIBIT B

**IN THE UNITED STATES DISTRICT COURT
FOR THE EASTERN DISTRICT OF WISCONSIN
MILWAUKEE DIVISION**

NUHN INDUSTRIES LTD.

Plaintiff,

v.

BAZOOKA FARMSTAR, LLC

and

TASCH'S CUSTOM LLC

Defendants.

CASE NO. 2:21-cv-01322

JURY TRIAL DEMANDED

FIRST AMENDED COMPLAINT FOR PATENT INFRINGEMENT

Plaintiff, Nuhn Industries, Ltd. (“Nuhn” or “Plaintiff”), for its Complaint against Defendants Bazooka Farmstar, LLC (“Bazooka”) and Tasch’s Custom LLC (“Tasch’s”) (collectively “Defendants”), alleges as follows:

NATURE OF THE ACTION

1. This is an action for patent infringement under 35 U.S.C. § 271, *et. seq.*, by Nuhn against Defendants for infringement of United States Patent No. 10,974,557 (“the ‘557 Patent”) (collectively “the Nuhn Patent”) by making, using, selling, and/or offering to sell the “Wolverine Agitation Boat” in the United States.

PARTIES

2. Nuhn is a corporation organized and existing under the laws of the province of Ontario, Canada, having a principal place of business at 4816 Line 34, Sebringville, ON N0K 1X0

Canada.

3. Among numerous other products, Nuhn markets an amphibious pumping vehicle for use in agitating manure lagoons, that is known as the Lagoon Crawler. The Lagoon Crawler is covered by claims of the Nuhn Patent.



4. Nuhn has sold the Lagoon Crawler to customers within this District.

5. On information and belief, Bazooka is a limited liability company organized and existing under the laws of the state of Iowa, having a principal place of business at 800 E. 7th Street, Washington, IA 52353. On information and belief, Bazooka is registered to do business in the State of Wisconsin and may be served through its registered agent Scott Szymanek 800 E. 7th Street, Washington, IA 52353.

6. On information and belief, Tasch's is a limited liability company organized and existing under the laws of the state of Wisconsin, having a principal place of business at N10212 St. Paul Rd., Malone, WI 53049. On information and belief, Tasch's is registered to do business in the State of Wisconsin and may be served through its registered agent Chad M. Tasch at N9900 Saint Paul Rd., Malone, WI 53049-1308.

JURISDICTION AND VENUE

7. This Court has subject matter jurisdiction over the matters asserted in this Complaint under 28 U.S.C. §§ 1331 and 1338(a) because the claims herein arise under the patent laws of the United States, 35 U.S.C. § 1 et seq., including 35 U.S.C. § 271.

8. On information and belief, Defendants are subject to this Court's specific and general personal jurisdiction, pursuant to due process and/or the Wisconsin Long Arm Statute, due at least to their substantial business in this forum, including at least because they have infringed the patent-in-suit directly and/or indirectly in this district. Defendants regularly transact business in the State of Wisconsin and within this District. Defendants engage in other persistent courses of conduct and derive substantial revenue from products and/or services in the State of Wisconsin and this District, and have purposefully established substantial, systematic, and continuous contacts within this District and should reasonably expect to be sued in a court in this District.

9. On information and belief, this Court has personal jurisdiction over Bazooka because it has committed acts of patent infringement and/or contributed to and/or induced acts of patent infringement by others in the State of Wisconsin and in this District. On information and belief, Bazooka directly has made, used, offered to sell, sold, and/or advertised (including through websites) in the United States, including to customers located within the State of Wisconsin and this District, including co-defendant Tasch's, products that infringe one or more claims of the Nuhn Patent. On information and belief, Bazooka has purposefully and voluntarily placed the infringing products into the stream of commerce with the awareness, expectation, and/or intent that they will be purchased by consumers in the State of Wisconsin and in this District.

10. On information and belief, this Court has personal jurisdiction over Tasch's because Tasch's is located in the State of Wisconsin and in this District. Further, Tasch's has

committed acts of patent infringement and/or contributed to and/or induced acts of patent infringement by others in the State of Wisconsin and in this District. On information and belief, Tasch's directly has offered to sell, sold, and/or advertised in the United States, including to customers located within the State of Wisconsin and this District, products that infringe one or more claims of the Nuhn Patent.

11. Venue is proper in this judicial district under 28 U.S.C. §§ 1391(b), (c) and 1400(b). On information and belief, Defendants have transacted business in this District and have committed acts of direct and indirect infringement in this District by, among other things, using, offering to sell, and selling products that infringe the Nuhn Patent to businesses in this District. At least Tasch's resides in this district. *See* 28 U.S.C. § 1400(b). Additionally, on information and belief, Bazooka and Tasch's have committed acts of infringement and have a regular and established place of business in this district. *See id.* Additional facts demonstrating that venue is proper in this judicial district are set forth below and incorporated into this paragraph by reference.

NUHN'S LEGACY OF INNOVATION

12. Nuhn is a family-owned business that was founded in 1902 as Nuhn Welding & Manufacturing in Wartburg, Ontario, Canada. Initially, the business specialized in making horseshoes.

13. Since its founding, Nuhn has consistently adapted to changing needs in the farming industry, creatively providing solutions to that industry. For example, in 1965, Dennis Nuhn made the company's first liquid manure spreader. The spreader was fabricated from an old gas tank with airplane tires.

14. Nuhn's legacy of creativity has led to the development of a broad patent portfolio consisting of innovative, unique designs related to the liquid manure handling industry. The first

such patent was an innovative dual tanker design that allows farmers to increase loads by up to 70%, with greater ease of handling.

15. An additional patented innovation is an alley vacuum that allows for the cleanup of manure in dairy barns. The inventions described and claimed in these patents have revolutionized how dairy barns are made and how liquid manure is handled.

16. As yet another example, Nuhn developed a multi-pump outlet that enables 30% more volume with the same horsepower as a conventional pump. This patented innovation has taken over the industry given the time savings, fuel savings, and better performance.

17. This lawsuit concerns another significant innovation from Nuhn, its Lagoon Crawler amphibious agitation vehicle, which is covered by the claims of the Nuhn Patent.

18. Prior to this innovation, in 2009-2010 the best solution for pumping out a manure lagoon was an agitator that required a long pump driven by a tractor along the bank of a lagoon. Depending on the size of the lagoon, as many as four pump/tractor combinations were required to adequately mix the lagoon, and not leave any solids behind. To the extent this pump/tractor method was not sufficiently effective, lagoon operators would be required to scoop out residual solids from the pit.

19. While other agitation boat devices were introduced to the market, they had numerous drawbacks that the Nuhn Patent overcame. For example, the Lagoon Crawler made it easier for the vehicle to enter and exit the lagoon. A typical lagoon has a berm that requires navigation both up and then back down. Prior art designs required a trailer to launch the boat. Compounding this difficulty was the fact that the terrain around a lagoon is often muddy and wet. Indeed, a typical problem with the prior art boats was that they would get stuck on the bank or enter the lagoon too quickly and nosedive under the liquid.



20. Relatedly, prior art designs were often ineffective in exiting the lagoon, either because they got stuck in the mud at the bottom of the lagoon or got stuck on “islands” of solid buildup in the lagoon. This could lead to safety concerns when a tractor used chains to pull the boat from the lagoon. If the boat was stuck in the mud, the chains were known to break, endangering the drivers of the tractors.

21. The inventions of the Nuhn Patent solved these considerable deficiencies in the prior art designs. As an all-terrain, amphibious vehicle, the Nuhn inventions allowed for superior agitation without fear of the vehicle becoming stuck either on the lagoon floor or islands of solid waste that may have formed. Indeed, the Lagoon Crawler, which is a commercial embodiment of the inventions claimed in the Nuhn Patent, was an instant success leading to significant commercial success, as well as copying by Bazooka and Tasch’s.

THE PATENT-IN-SUIT

22. On April 13, 2021, U.S. Patent No. 10,974,557, entitled “Amphibious Pumping

Vehicle,” was duly and legally issued by the United States Patent and Trademark Office. A true and accurate copy of the ‘557 Patent is attached hereto as Exhibit 1.

THE WOLVERINE SERIES AGITATION BOAT

23. Upon information and belief, in early 2021, Bazooka began marketing its Wolverine Series Agitation Boat. *See* May 13, 2021, video published on YouTube.com (<https://www.youtube.com/watch?v=ehAHKL442as>).

24. The Wolverine Series Agitation Boat is marketed as a floating vehicle that can be driven into a manure lagoon in view of four “large diameter, aggressive tires [that] make climbing out of steep banks effortless.” (<https://bazookafarmstar.com/wolverine-series/>).

25. The Wolverine Series Agitation Boat also includes a fluid nozzle connected to a pump. The pump is powered by an engine. (https://bazookafarmstar.com/wp-content/uploads/2021/05/IMG_3850-straightened-1024x683.jpg).



26. Lastly, Bazooka advertises that the Wolverine Series Agitation Boat is controllable by a remote control. (<https://bazookafarmstar.com/wp-content/uploads/2021/04/GOPR1101-1620x1080.jpg>).



27. Upon information and belief, Bazooka has made, used, sold, and/or offered for sale the Wolverine Series Agitation Boat in this District, including to Tasch's.

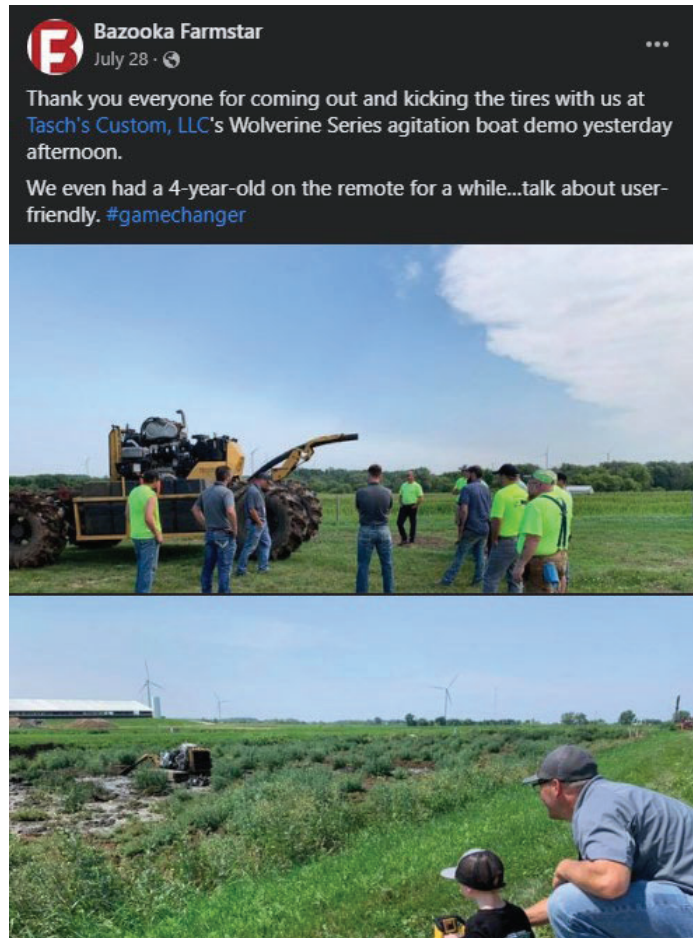

(<https://www.facebook.com/bazookafarmstar>)

28. Bazooka has a regular and established place of business in this judicial district via its distributor, Tasch's. On the home page of Bazooka's website, it has five drop down menus along the top of the website. One of those menus states "FIND US":



(<https://www.bazookafarmstar.com/>)

29. Under the "FIND US" menu, are three choices, including a "Dealer Locator." That locator leads to the following map, showing the Bazooka logo covering a portion of this judicial district:

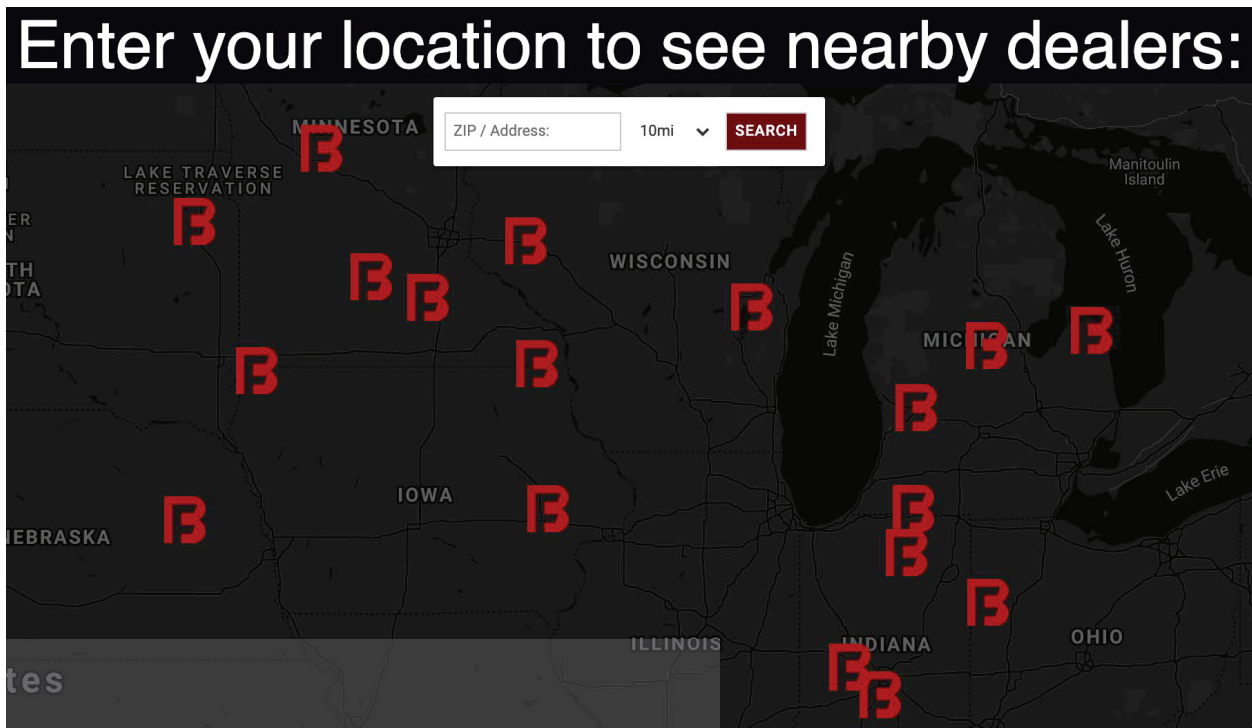

(<https://www.bazookafarmstar.com/dealer-locator/>)

30. Upon information and belief, Bazooka also solicits orders for the Wolverine Series Agitation Boat on its own website for the benefit of its distributors, such as Tasch's ("...so

we can best align with your business goals and *an official dealer nearest you.*”) (emphasis added):

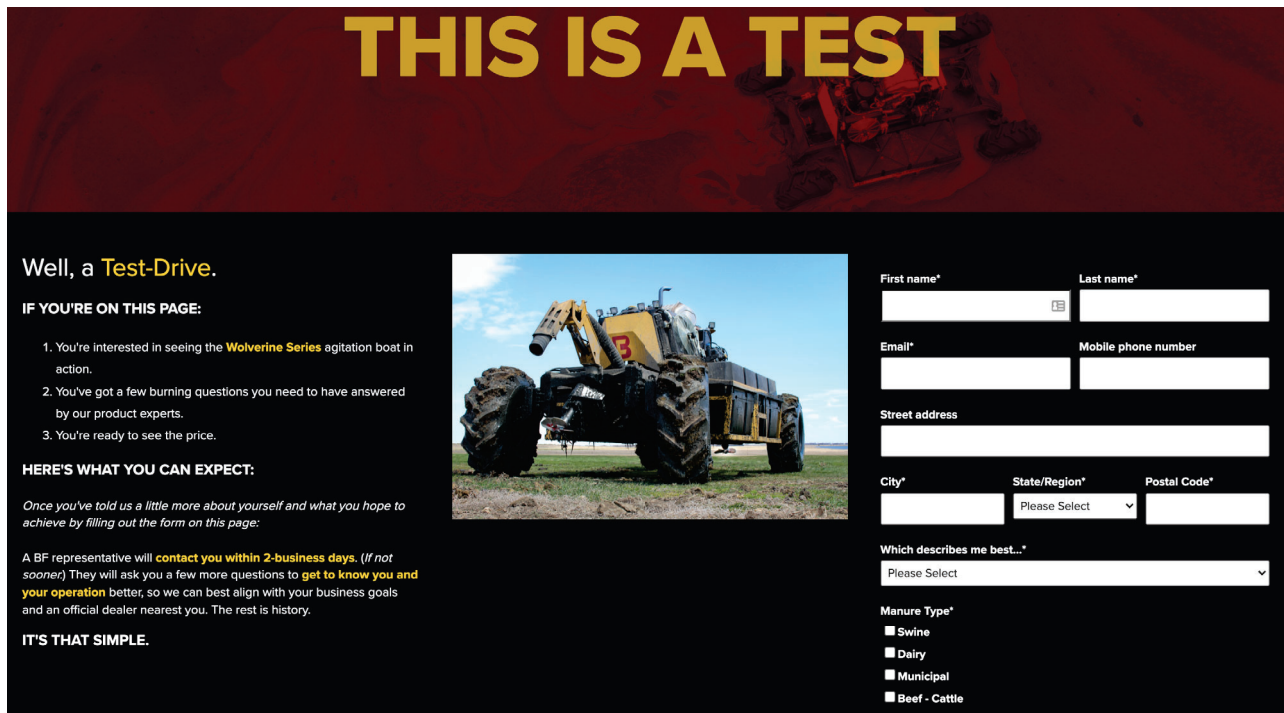

(<https://gamechanger.bazookafarmstar.com/request-a-demo-with-bazooka-farmstar-0>)

31. Tasch’s website, in turn, points out that its dealership is directed to supporting Bazooka and one other company:



(<https://taschscustomllc.com/>)

32. On its Facebook social media page, Tasch’s has, in the past nine months exclusively advertised its relationship with Bazooka. Indeed, since the Wolverine Series

Agitation Boat was introduced on May 13, 2021, ten of the twelve exclusively Bazooka-related posts on Facebook have been directed to the accused device. *See* Exhibit 2.

33. The above-referenced social media posts include re-postings of Bazooka’s Facebook postings relating to the Wolverine Series Agitation Boat.

34. Upon information and belief, Tasch’s has also used, sold, and/or offered for sale the Wolverine Series Agitation Boat in this district, including on the Manure Equipment for Sale website.

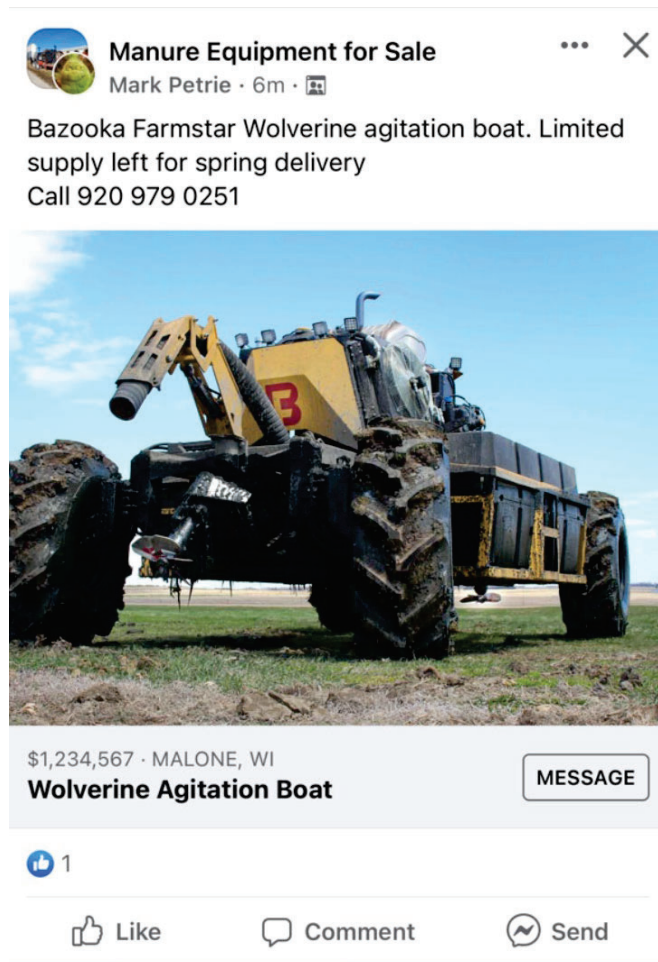

35. Upon information and belief, Tasch’s has also used, sold, and/or offered for sale the Wolverine Series Agitation Boat in this district, including to BHF Pumping of Campbellsport, Wisconsin.

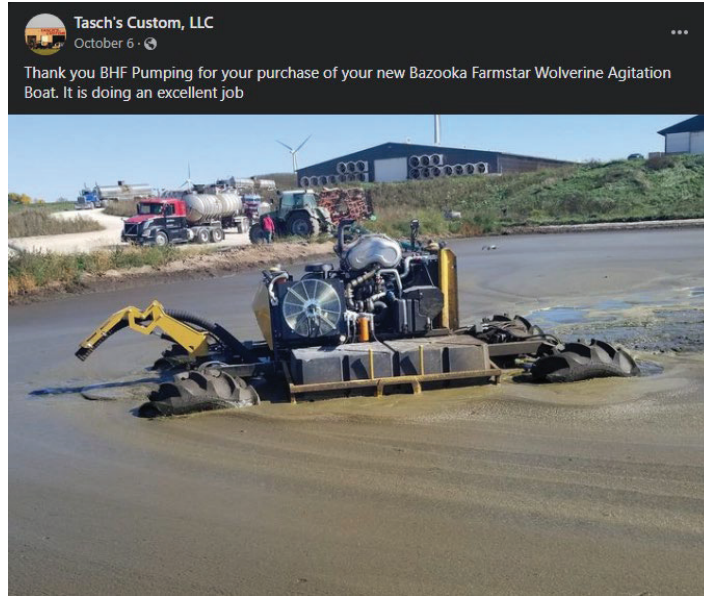

(<https://www.facebook.com/taschscustomllc>).

36. Upon information and belief, Tasch's has also used, sold, and/or offered for sale the Wolverine Series Agitation Boat to Dvorachek Farm & Industry, LLC of Billion, Wisconsin.

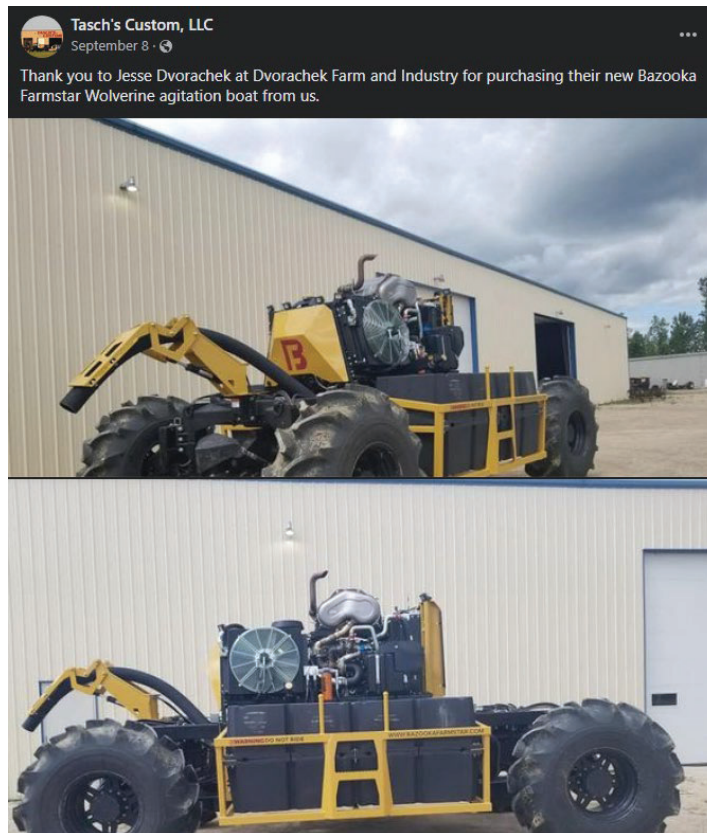

(<https://www.facebook.com/taschscustomllc>)

37. Upon information and belief, Tasch's has also used, sold, and/or offered for sale the Wolverine Series Agitation Boat to Eisentraut AG Services of Waldo, Wisconsin.

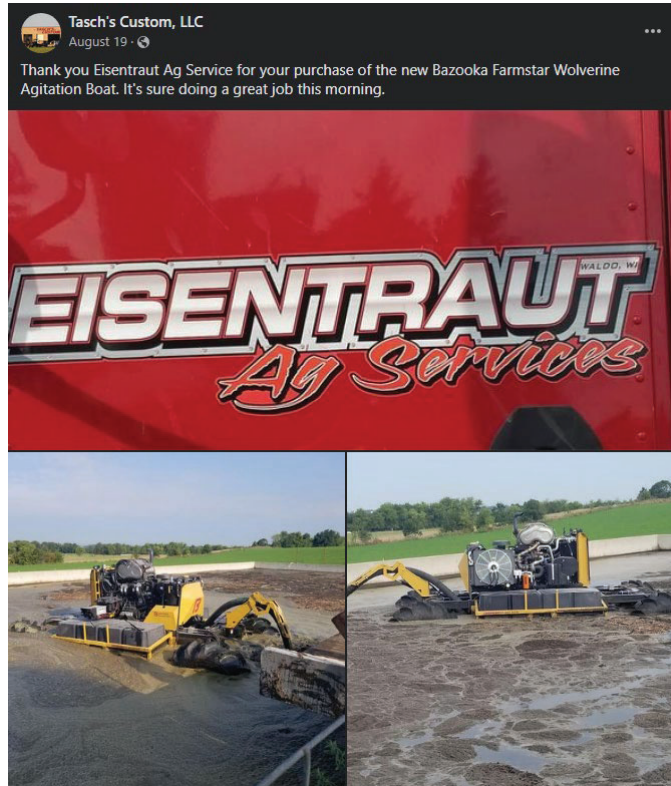

(<https://www.facebook.com/taschscustomllc>)

38. Upon information and belief, Tasch's has performed repairs to one or more Wolverine Series Agitation Boats in this judicial district. As such, Tasch's serves as more than a mere sales arm of Bazooka, but also services the accused devices.

39. The three elements of 28 USC 1400(b) are met here. *See In re Cray Inc.*, 871 F.3d 1355, 1360 (Fed. Cir. 2017). Bazooka has a physical place in this district, it is a regular and established place of business of Bazooka's, and it is the place of Bazooka's.

DEFENDANTS' KNOWLEDGE OF THE PATENT-IN-SUIT

40. On April 14, 2021, Bazooka was notified of its infringement by way of the letter

attached hereto as Exhibit 3.

41. On November 24, 2021, Tasch's was notified of its infringement by way of the service of an original complaint by Nuhn's. Despite this knowledge, Tasch's has continued to offer for sale the Wolverine Series Agitation Boat in this judicial district, as evidenced below in a social media posting as recently as December 31, 2021.

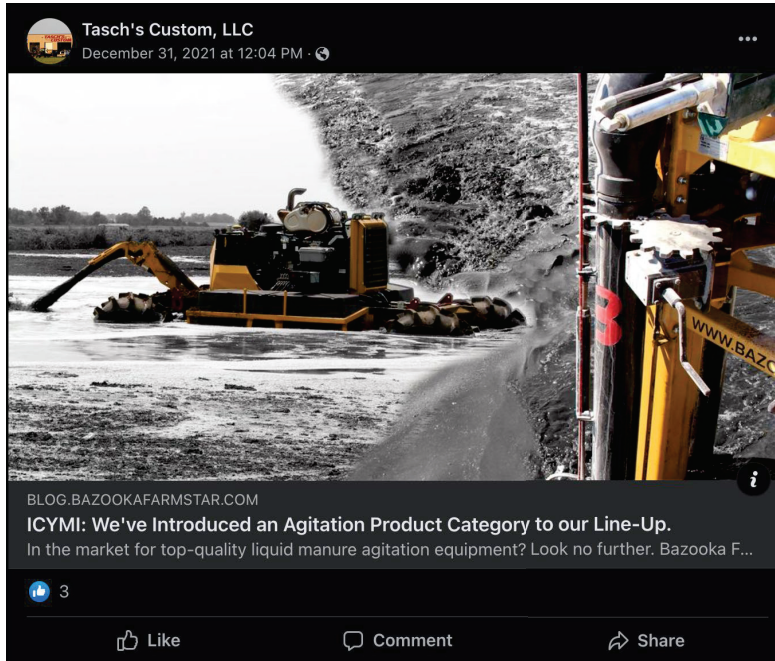

FIRST CAUSE OF ACTION

(Infringement of the '557 Patent by Bazooka)

42. Nuhn incorporates by reference and realleges each and every allegation of the previous paragraphs as if set forth herein.

43. Nuhn owns all substantial right, title, and interest in and to the '557 Patent, including the sole and exclusive right to prosecute this action and enforce the '557 Patent against infringers, and to collect damages for all relevant times.

44. The '557 Patent generally describes an amphibious vehicle that is equipped for pumping, including the pumping of liquid manure, such as animal manure contained in a farm

lagoon.

45. The written description of the '557 Patent describes in technical detail each of the limitations of the claims, allowing a skilled artisan to understand the scope of the claims and how the non-conventional and non-generic combination of claim limitations is patentably distinct from and improved upon what may have been considered conventional or generic in the art at the time of the invention.

46. Bazooka has made, used, sold, and/or offered for sale products, including its Wolverine Series Agitation Boat, that infringe one or more claims of the '557 Patent.

47. As set forth in the attached non-limiting claim chart (Exhibit 4), upon information and belief, Bazooka, without authorization or license from Nuhn, has directly infringed and continues to directly infringe at least Claim 1 of the '557 Patent, either literally or under the doctrine of equivalents, by making, having made, using, distributing, selling, and/or offering for sale the Wolverine Series Agitation Boat.

48. Nuhn has been damaged as a result of the infringing conduct by Bazooka alleged above. Thus, Bazooka is liable to Nuhn in an amount that compensates it for such infringement, which by law cannot be less than a reasonable royalty, together with interest and costs as fixed by this Court under 35 U.S.C. § 284.

49. Bazooka's infringement of the '557 Patent has caused, and will continue to cause, Nuhn to suffer substantial and irreparable harm.

50. Nuhn is entitled to injunctive relief in accordance with 35 U.S.C. § 283.

51. Bazooka has been aware that it infringes the '557 Patent since at least April 14, 2021, upon the receipt of the letter attached as Exhibit 3. Since obtaining knowledge of its infringing activities, Bazooka has failed to cease its infringing activities.

52. Bazooka's infringement of the '557 Patent is, has been, and continues to be, willful, intentional, deliberate, and/or in conscious disregard of Nuhn's rights under the patent, justifying a trebling of damages under 35 U.S.C. § 284.

53. Bazooka's infringement is exceptional and entitles Nuhn to attorneys' fees and costs under 35 U.S.C. § 285.

54. Nuhn has complied with the marking requirements of 35 U.S.C. § 287 with respect to the '557 Patent.

SECOND CAUSE OF ACTION

(Infringement of the '557 Patent by Tasch's)

55. Nuhn incorporates by reference and realleges each and every allegation of the previous paragraphs as if set forth herein.

56. Tasch's has used, sold, and/or offered for sale products, including the Wolverine Series Agitation Boat, that infringe one or more claims of the '557 Patent.

57. As set forth in the attached non-limiting claim chart (Exhibit 4), upon information and belief, Tasch's, without authorization or license from Nuhn, has directly infringed and continues to directly infringe at least Claim 1 of the '557 Patent, either literally or under the doctrine of equivalents, by using, distributing, selling, and/or offering for sale the Wolverine Series Agitation Boat.

58. Nuhn has been damaged as a result of the infringing conduct by Tasch's alleged above. Thus, Tasch's is liable to Nuhn in an amount that compensates it for such infringement, which by law cannot be less than a reasonable royalty, together with interest and costs as fixed by this Court under 35 U.S.C. § 284.

59. Tasch's infringement of the '557 Patent has caused, and will continue to cause,

Nuhn to suffer substantial and irreparable harm.

60. Nuhn is entitled to injunctive relief in accordance with 35 U.S.C. § 283.

61. Tasch's has been aware that it infringes the '557 Patent since at least November 24, 2021, upon the service of the original complaint in this matter. Since obtaining knowledge of its infringing activities, Tasch's has failed to cease its infringing activities.

62. Tasch's infringement of the '557 Patent is, has been, and continues to be, willful, intentional, deliberate, and/or in conscious disregard of Nuhn's rights under the patent, justifying a trebling of damages under 35 U.S.C. § 284.

63. Tasch's infringement is exceptional and entitles Nuhn to attorneys' fees and costs under 35 U.S.C. § 285.

64. Nuhn has complied with the marking requirements of 35 U.S.C. § 287 with respect to the '557 Patent.

PRAYER FOR RELIEF

Wherefore, Nuhn respectfully requests that the Court enter judgment in its favor and against Defendants on the patent infringement claims set forth above and respectfully requests that this Court:

- (a) enter judgment that, under 35 U.S.C. §§ 271(a) and (b), both Bazooka and Tasch's have directly infringed at least one claim of the '557 Patent;
- (b) in accordance with 35 U.S.C. § 283, enjoin Defendants, and all affiliates, employees, agents, officers, directors, attorneys, successors, and assigns and all those acting on behalf of or in active concert or participation with Defendants, preliminarily and permanently from infringing the '557 Patent;
- (c) award Nuhn all available and legally permissible damages and relief sufficient to

compensate Nuhn for Defendants' infringement of the '557 Patent, including to the full extent permitted by 35 U.S.C. § 284, together with interest, in an amount to be determined at trial;

- (d) award Nuhn treble damages under 35 U.S.C. § 284 as a result of Bazooka's and Tasch's willful and deliberate infringement of the '557 Patent;
- (e) declare this to be an exceptional case under 35 U.S.C. § 285 and award Nuhn costs, expenses, and disbursements in this action, including reasonable attorneys' fees; and
- (f) award Nuhn such other and further relief that this Court deems just and proper.

JURY DEMAND

Pursuant to Rule 38(b) of the Federal Rules of Civil Procedure, Nuhn hereby demands a trial by jury on all issues triable of right by a jury.

Date: January 12, 2022

/s/Scott E. Yackey
HARNESS, DICKEY & PIERCE, P.L.C.
Scott E. Yackey (TX Bar Number 24100052)
2801 Network Blvd., Suite 600
Frisco, TX 75034
Telephone: (469) 777-5400
Facsimile: (469) 777-5401
syackey@harnessip.com

Matthew L. Cutler (MO Bar Number 46305)
(To be admitted to practice)
7700 Bonhomme, Suite 400
Clayton, MO 63105
Telephone: (314) 726-7500
Facsimile: (314) 726-7501
mcutler@harnessip.com

Attorneys for Plaintiff, Nuhn Industries, Ltd.

EXHIBIT C



US010974557B2

(12) **United States Patent**
Nuhn

(10) **Patent No.:** **US 10,974,557 B2**
(45) **Date of Patent:** ***Apr. 13, 2021**

- (54) **AMPHIBIOUS PUMPING VEHICLE**
- (71) Applicant: **Nuhn Industries Ltd.**, Sebringville (CA)
- (72) Inventor: **Ian Nuhn**, Sebringville (CA)
- (73) Assignee: **Nuhn Industries Ltd.**, Sebringville (CA)

- (56) **References Cited**
- U.S. PATENT DOCUMENTS
- 1,943,152 A 1/1934 Weiss
- 2,586,218 A * 2/1952 Gazda B60F 3/0015 440/95

(Continued)

FOREIGN PATENT DOCUMENTS

- (*) Notice: Subject to any disclaimer, the term of this patent is extended or adjusted under 35 U.S.C. 154(b) by 0 days.
- This patent is subject to a terminal disclaimer.

- CA 2002619 A1 5/1991
 - DE 2364962 A1 7/1975
- (Continued)

OTHER PUBLICATIONS

(21) Appl. No.: **16/891,627**

International Search Report and Written Opinion, PCT/CA2014/050789, dated Nov. 5, 2014.

(22) Filed: **Jun. 3, 2020**

(Continued)

- (65) **Prior Publication Data**
- US 2020/0290415 A1 Sep. 17, 2020

Related U.S. Application Data

- (63) Continuation of application No. 16/157,950, filed on Oct. 11, 2018, now Pat. No. 10,710,422, which is a (Continued)

Primary Examiner — Stephen P Avila
(74) *Attorney, Agent, or Firm* — Brunet & Co. Ltd.; Robert Brunet; Hans Koenig

- (51) **Int. Cl.**
 - B60F 3/00** (2006.01)
 - A01C 23/04** (2006.01)
- (Continued)

(57) **ABSTRACT**

An amphibious pumping vehicle has a floatable vehicle body, a ground engaging propulsion structure, a fluid pump, a plurality of fluid nozzles comprising a first fluid nozzle connected by a fluid conduit to the fluid pump and at least one second fluid nozzle connected to the fluid conduit, a valve structure in the fluid conduit, the plurality of fluid nozzles and the valve structure co-operating to provide directional control and motive power for the vehicle when floating, and a power source configured to provide power to both the ground engaging propulsion structure and the fluid pump.

- (52) **U.S. Cl.**
- CPC **B60F 3/0061** (2013.01); **A01C 3/026** (2013.01); **A01C 23/045** (2013.01); **B60F 3/003** (2013.01);
- (Continued)
- (58) **Field of Classification Search**
- CPC B60F 3/00; B60F 3/0061; B60F 3/0007; B60F 3/003; B60F 3/0038
- See application file for complete search history.

13 Claims, 7 Drawing Sheets

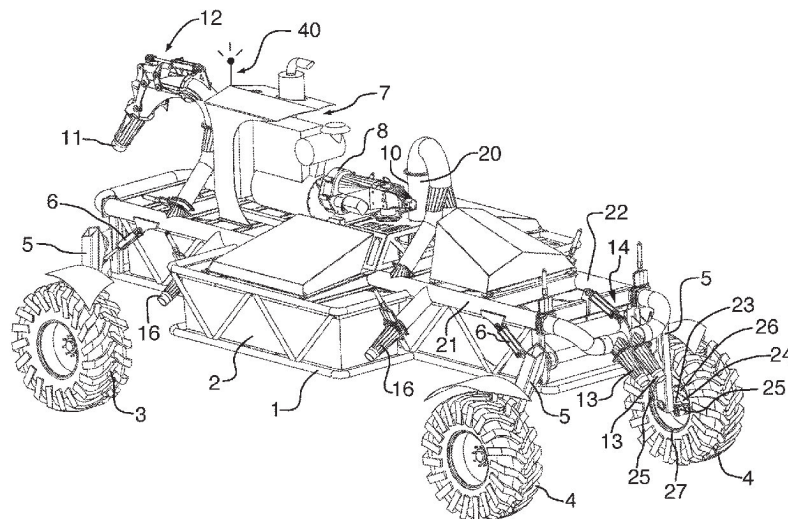

US 10,974,557 B2

Page 2

Related U.S. Application Data

continuation of application No. 15/586,493, filed on May 4, 2017, now Pat. No. 10,124,638, which is a continuation of application No. 15/044,905, filed on Feb. 16, 2016, now Pat. No. 9,694,636, which is a continuation of application No. PCT/CA2014/050789, filed on Aug. 18, 2014.

4,594,006	A	6/1986	Depeault	
5,176,098	A	1/1993	Royle	
9,694,636	B2 *	7/2017	Nuhn	A01C 3/026
10,124,638	B2 *	11/2018	Nuhn	A01C 23/045
10,710,422	B2 *	7/2020	Nuhn	A01C 3/026
2010/0144220	A1	6/2010	Bailey	
2013/0145980	A1	6/2013	Puck	
2014/0112093	A1	4/2014	Puck	
2014/0288763	A1 *	9/2014	Bennett	B62D 11/18 701/31.6
2015/0258868	A1	9/2015	Visscher	

(60) Provisional application No. 61/867,598, filed on Aug. 19, 2013.

(51) **Int. Cl.**

A01C 3/02 (2006.01)
B63H 25/02 (2006.01)
F04D 13/02 (2006.01)

DE	3431345	A1	3/1986
WO	2008/038029	A2	4/2008

FOREIGN PATENT DOCUMENTS

(52) **U.S. Cl.**

CPC **B60F 3/0007** (2013.01); **B60F 3/0038** (2013.01); **B63H 25/02** (2013.01); **F04D 13/02** (2013.01); **B60F 2301/00** (2013.01); **B63H 2025/028** (2013.01)

OTHER PUBLICATIONS

Translation of Chinese Office Action dated Mar. 2, 2017 on CN 201480053275.
 Translation of Chinese Office Action dated Nov. 6, 2017 on CN 201480053275.
 Office Action dated Aug. 23, 2018 on EA 201690422-31.
 Office action dated Jan. 5, 2017 on U.S. Appl. No. 15/044,905.
 Office action dated Aug. 23, 2017 on U.S. Appl. No. 15/586,493.
 Office action dated Dec. 15, 2017 on U.S. Appl. No. 15/586,493.
 Office action dated Nov. 21, 2019 on U.S. Appl. No. 16/157,950.

(56) **References Cited**

U.S. PATENT DOCUMENTS

3,384,047	A	5/1968	Remley
4,406,413	A	9/1983	Houle

* cited by examiner

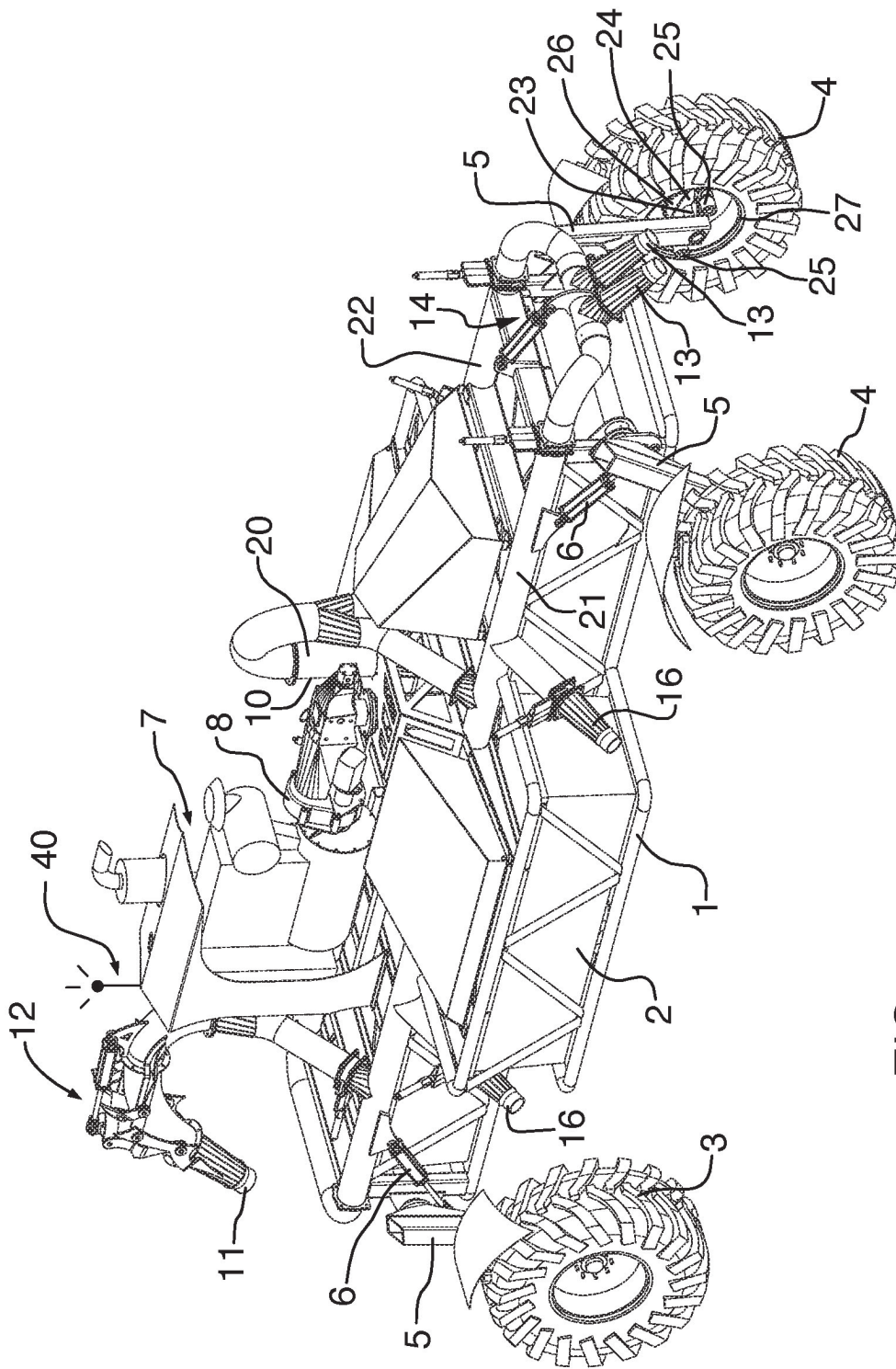

FIG.1

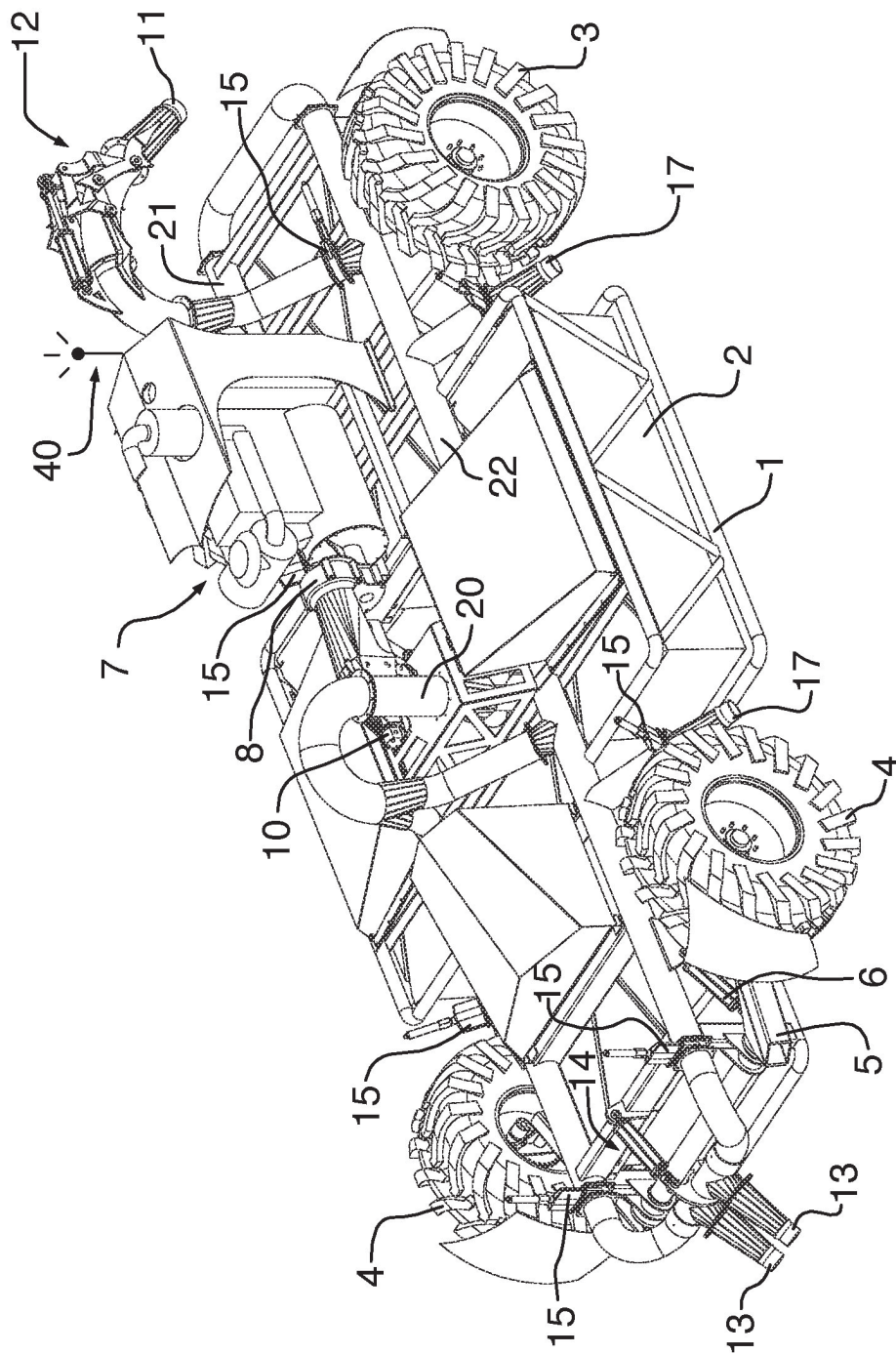

FIG. 2

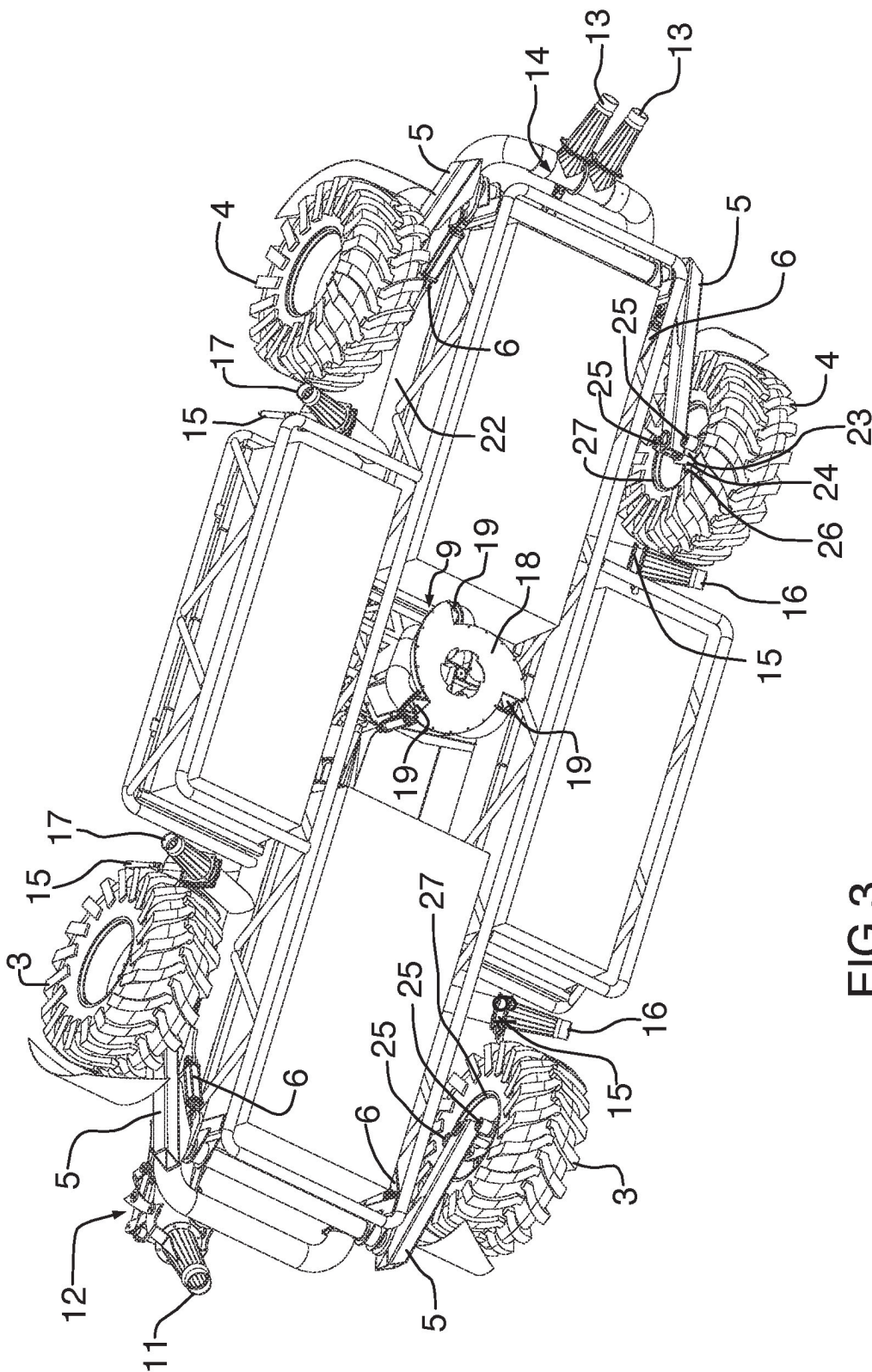

FIG.3

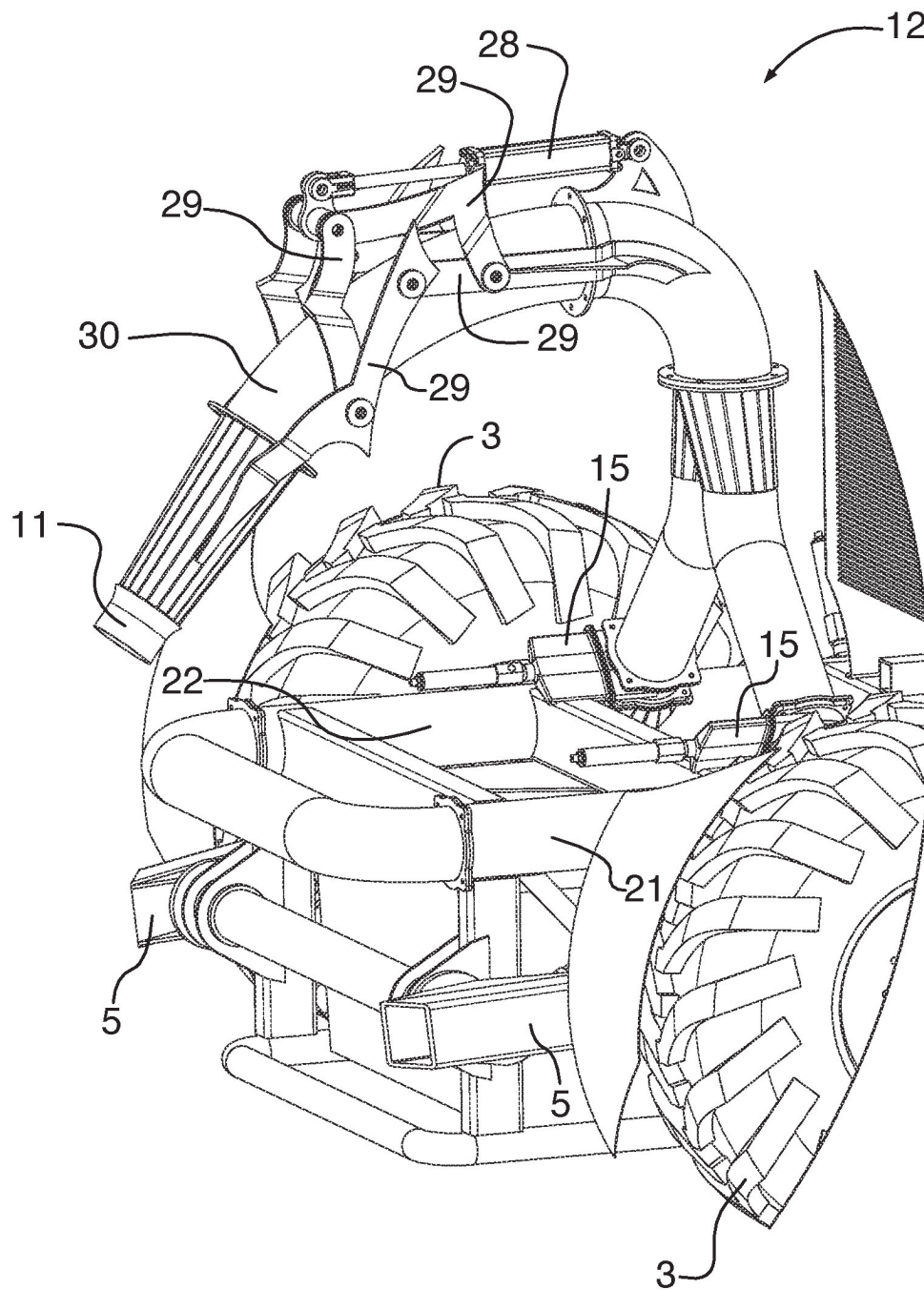

FIG. 5

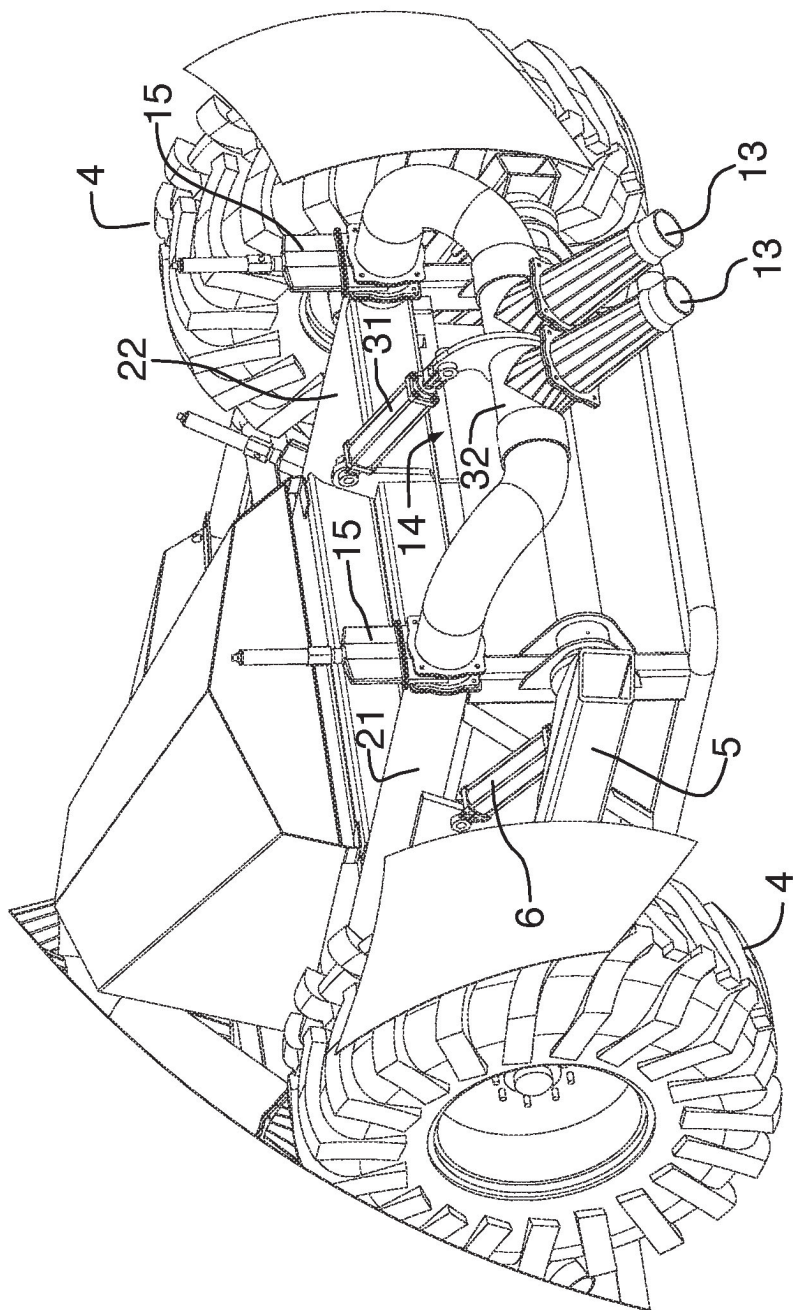

FIG.6

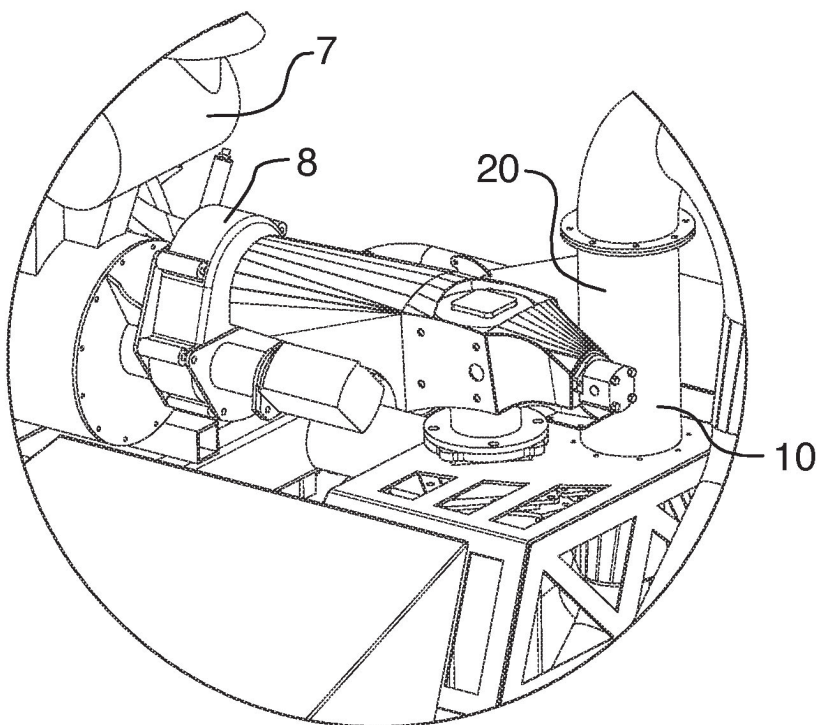

FIG. 7

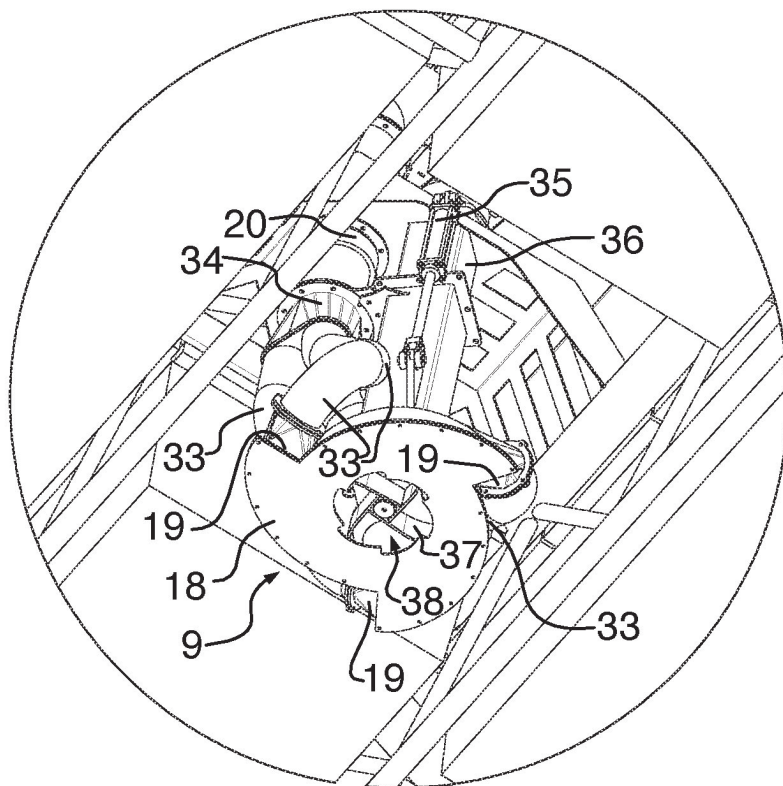

FIG. 8

US 10,974,557 B2

1

AMPHIBIOUS PUMPING VEHICLE**CROSS-REFERENCE TO RELATED APPLICATIONS**

This application is a continuation of U.S. patent application Ser. No. 16/157,950, filed Oct 11, 2018 now issued under U.S. Pat. No. 10,710,422 on Jul. 14, 2020, which is a continuation of U.S. Ser. No. 15/586,493 filed May 4, 2017, now issued under U.S. Pat. No. 10,124,638 on Nov. 13, 2018, which is a continuation of U.S. patent application Ser. No. 15/044,905 filed Feb. 16, 2016 now issued under U.S. Pat. No. 9,694,636 on Jul. 4, 2017, which is a continuation of international patent application PCT/CA2014/050789, filed Aug. 18, 2014, which claims the benefit of U.S. patent application Ser. No. 61/867,598 filed Aug. 19, 2013, the entire contents of which are herein incorporated by reference.

TECHNICAL FIELD

The invention relates to pumps and vehicles equipped for pumping. In particular, the invention relates to manure pumps and amphibious vehicles equipped for pumping liquid manure, such as animal manure contained in a farm lagoon.

BACKGROUND

Manure produced during animal husbandry, particularly hog and cattle manure, is transferred by washing to a pit or lagoon for storage prior to removal for land application or further processing. During storage, a crust can develop on the surface of the pit or lagoon that must be disrupted prior to or during removal of the manure. Pumps are employed for this purpose with jets that return a percentage of the manure back to the pit or lagoon in the form of a high volume spray to disrupt the crust and recirculate the manure. Pumps for use in recirculating manure from smaller pits are known; however, these pumps are typically suitable for accessing the pit or lagoon from its edge and are connected to a tractor or similar land vehicle for operational power. They are therefore limited in their ability to recirculate manure to the middle of large lagoons, which are becoming increasing common as the size of animal husbandry operations increases.

Accordingly, there is a need for improved pumps and vehicles equipped for pumping, particularly pumps and vehicles suitable for use with large manure lagoons.

SUMMARY OF THE INVENTION

According to the invention, there is provided an amphibious pumping vehicle comprising: a floatable vehicle body; ground engaging propulsion structure configured to raise and lower relative to the vehicle body; a fluid pump; a first fluid nozzle configured to direct fluid through the air, the fluid nozzle connected by a fluid conduit to the fluid pump; and, a power source configured to provide power to both the ground engaging propulsion structure and the fluid pump.

The floatable vehicle body may be in the shape of a mono-hull, a catamaran or a barge. Floatation of the vehicle body may be provided by a displacement hull, pontoon elements, or buoyant elements, for example foam filled buoyant chambers, such as are used for supporting floating

2

docks. The vehicle body may be made using a variety of suitable materials, for example, fiberglass, aluminum, plastics, steel, etc.

The ground engaging propulsion structure may comprise ground engaging elements of the type suitable for powering a vehicle across wet or muddy terrain. For example, the ground engaging propulsion structure may comprise an endless track or a set of wheels. The set of wheels may comprise two or more wheels, for example four wheels, six wheels or eight wheels. May be provided in pairs with one wheel of each pair disposed on opposite sides of the vehicle. When the vehicle comprises a set of wheels, any number of the wheels may be driven in order to provide propulsion for the vehicle. Although at least two wheels may be driven, it is preferred that at least four wheels are driven. Although the vehicle may be provided with steering structure configured to change direction of one or more pairs of wheels, it is preferred that the wheels are independently driven at variable speeds, allowing them to be fixed in direction relative to the vehicle body. This provides directional control of the vehicle, even in wet or muddy conditions where conventional steering is likely to be ineffective due to sliding of the steerable set of wheels. A variety of drive mechanisms may be used to operate the wheels independently at variable speed; for example, at least one motor may be connected to each wheel that is hydraulically or electrically operable at variable speed. A transmission may alternatively be provided with structure configured to allow each wheel to be operated at variable speeds.

The ground engaging propulsion structure is configured to raise and lower relative to the vehicle body. Raising and lowering may be provided by telescoping structure or lever structure configured to pivot relative to the vehicle body. The lever structure may comprise a linear actuator that is driven, for example hydraulically, to cause pivoting of the lever arm relative to the vehicle body and thereby raise or lower the wheels. Each wheel is preferably raised or lowered at the same time. Alternatively, the lever structure may comprise a planetary drive that is either mechanically or hydraulically powered to cause pivoting of the lever arm.

The vehicle further comprises a power source configured to provide power to both the ground engaging propulsion structure and the fluid pump. The power source may be self-contained on the vehicle or may be linked to shore. For example, the power source may comprise an internal combustion engine, a fuel-cell, electric batteries, etc. The power source may comprise an electric motor that may be driven from shore via an electrical cable. The power source may be connected to a generator for supplying electrical power to electrical systems on board the vehicle. The power source may be connected to a hydraulic pump for supplying hydraulic fluid pressure to hydraulic systems on board the vehicle. The power source may be connected to the fluid pump hydraulically, electrically, or via a mechanical drive. A single power source may be used to provide power to all vehicle systems, including the fluid pump. In one embodiment, the power source is an internal combustion engine that is connected to the fluid pump and a hydraulic pump via a mechanical drive. The mechanical drive may comprise a gearbox to provide an appropriate rotational speed for the fluid pump. The mechanical drive may comprise a gearbox to provide an appropriate rotational speed for the hydraulic pump. The fluid pump and hydraulic pump may be operated at the same or different rotational speeds.

The fluid pump may comprise a pump housing configured for immersion within the fluid. The pump housing may comprise a bottom fluid inlet and at least two tangential fluid

US 10,974,557 B2

3

outlets. A greater number of tangential fluid outlets may be provided, for example three fluid outlets. The tangential fluid outlets may be combined into a single fluid conduit for directing the combined output of the fluid pump to a desired location. The vehicle may comprise structure configured to cause raising and lowering of the fluid pump, especially the fluid pump housing, relative to the vehicle body. For example, a hydraulically or electrically driven linear actuator may be provided on the vehicle and configured to raise and lower the fluid pump. This may be accomplished via a telescoping structure or a lever structure of the vehicle. The tangential fluid outlets may be equipped with flexible or telescoping connections to the single fluid conduit. Lowering the fluid pump for immersion into the fluid obviates the need for priming the fluid pump, which can be problematic when the fluid is manure comprising solid materials that can plug the pump or priming structure. Immersion of the pump also simplifies intermittent operation of the pump, due to eliminating potential loss of prime, and reduces the need for pump maintenance.

The vehicle comprises a first fluid nozzle configured to direct fluid through the air. The fluid nozzle is connected by fluid conduit to the fluid pump. The fluid conduit connecting the fluid nozzle to the fluid pump may comprise the single fluid conduit that is connected to the tangential fluid outlets of the pump. The vehicle may further comprise a plurality of fluid nozzles comprising the first fluid nozzle and at least one second fluid nozzle connected to the fluid conduit. The first fluid nozzle may comprise a front nozzle and the second fluid conduit may comprise the rear nozzle or a pair of rear nozzles. The plurality of fluid nozzles may comprise at least two side fluid nozzles on opposite sides of vehicle connected to the fluid conduit. The at least two side fluid nozzles may comprise a pair of fluid nozzles on opposite sides of the vehicle connected to the fluid conduit; thus, the at least two side fluid nozzles may comprise a total of four fluid nozzles. The vehicle may further comprise valve structure configured to proportion fluid flow between the plurality of fluid nozzles. The valve structure may comprise a valve corresponding to each fluid nozzle. The valve corresponding to each fluid nozzle may be actuatable, for example hydraulically or electrically. The valve structure may be actuatable remotely.

The plurality of fluid nozzles and the valve structure may cooperate to provide directional control, motive power, or a combination thereof for the vehicle when floating. For example, by closing valve structure associated with the fluid nozzle(s) on the right side of the vehicle, fluid flow is directed to the nozzle(s) on the left side of the vehicle, causing the vehicle to turn to the right. In one embodiment, steering is achieved solely by cooperation of the plurality of fluid nozzles and the valve structure; accordingly, the vehicle does not comprise a rudder. In one embodiment, movement of the vehicle while floating is achieved solely by cooperation of at least the second fluid nozzle and the valve structure; accordingly, the vehicle does not comprise a propeller.

One or more fluid nozzles may comprise adjustment structure that is powered and configured to adjust an angle of the fluid nozzle relative to the floatable vehicle body. For example, the first fluid nozzle may comprise first adjustment structure and the second fluid nozzle(s) may comprise second adjustment structure, each adjustment structure configured to adjust an angular orientation of its respective fluid nozzle(s) in a vertical and/or horizontal plane. In one embodiment, both the first fluid nozzle and the second fluid nozzle(s) are adjustable in a vertical plane. The second fluid

4

nozzle(s) is/are adjustable in the vertical plane by an amount sufficient to cause forward or backward movement of the vehicle when floating. In other words, the second fluid nozzle(s) is/are adjustable to point at least partially toward the front of the vehicle at least partially toward the rear of the vehicle. The second fluid nozzle(s) may be configured to direct fluid through the air in a substantially downward direction. The first fluid nozzle may be configured to direct fluid through the air in a substantially upward direction. The side fluid nozzle(s) may be configured to direct fluid through the air in a substantially downward direction. One or more side fluid nozzle(s) may comprise adjustment structure configured to adjust an angular orientation of its respective side fluid nozzle(s) in a vertical plane.

The location of at least the ground engaging propulsion structure, the power source and the fluid pump may be selected to provide a desired location for a center of gravity of the vehicle. The desired location for the center of gravity of the vehicle may be selected to improve handling characteristics of the vehicle while floating. The center of gravity may be located along the longitudinal centerline of the vehicle. The center of gravity may be located substantially in the middle of the vehicle, for example at an intersection of longitudinal centerline of the vehicle and the transverse centerline of the vehicle. The center of gravity may be located rearward of the transverse centerline of the vehicle. The center of gravity may be located forward of the transverse centerline of the vehicle. Thus the ground engaging propulsion structure, power source, and fluid pump cooperate together to improve handling characteristics of the vehicle.

The vehicle may comprise remote control structure configured to cause the vehicle to be remotely controllable by an operator remote from the vehicle. The vehicle may be remotely controllable by an operator remote from the vehicle when the vehicle is ground engaging and when the vehicle is floating. The remote control structure may comprise a wireless transmitter and a wireless receiver. The remote control structure may be configured to control the speed and or direction of the vehicle when ground engaging and when floating. The remote control structure may be configured to control an amount of fluid flow from at least the first nozzle. The remote control structure may be configured to control an angular orientation of at least the first nozzle relative to the vehicle body. The remote control structure may be configured to control an amount of fluid flow from at least the second nozzle(s). The remote control structure may be configured to control an angular orientation of at least the second nozzle(s) relative to the vehicle body. The remote control structure may be configured to control the valve structure in order to proportion fluid flow between the plurality of fluid nozzles. The remote control structure may be configured to control rotational speed of the fluid pump. The remote control structure may be configured to raise and lower the fluid pump. The remote control structure may be configured to raise and lower the ground engaging propulsion structure. The remote control structure may be configured to start and stop the power source.

Further features of the invention will be described or will become apparent in the course of the following description.

BRIEF DESCRIPTION OF THE DRAWINGS

In order that the invention may be more clearly understood, embodiments thereof will now be described in detail by way of example, with reference to the accompanying drawings, in which:

US 10,974,557 B2

5

FIG. 1 shows a perspective view of an embodiment of the vehicle with wheels lowered;

FIG. 2 shows another perspective view of the vehicle with wheels raised;

FIG. 3 shows a perspective view of the underside of the vehicle; and,

FIG. 4 shows a perspective view of a set of wheels of the vehicle from the underside of the vehicle;

FIG. 5 shows a perspective view of the first fluid nozzle of vehicle;

FIG. 6 shows a perspective view of a second fluid nozzle of the vehicle;

FIG. 7 shows a perspective view of a mechanical drive connecting the power source of the vehicle to the fluid pump and a hydraulic pump of the vehicle;

FIG. 8 shows a perspective view of the fluid pump from the underside of the vehicle.

DETAILED DESCRIPTION

In describing the figures, like features are referred to by like reference numerals. Although not all features indicated on a particular drawing are necessarily described with reference to that drawing, all of the features are described with reference to at least one of the drawings.

Referring to FIGS. 1-3, an amphibious vehicle comprises a vehicle body 1 incorporating buoyant elements 2. The buoyant elements comprise flotation tanks of the type that may be foam filled and used, for example, in the construction of floating docks. The vehicle comprises a ground engaging propulsion structure comprising two sets of wheels 3, 4. Each wheel is rotatably mounted to lever structure 5 that is pivotally attached to the vehicle body. Each lever structure 5 is driven by a hydraulic actuator 6 that is operable to cause raising and lowering of the wheels 3, 4 by pivoting of the lever structure 5. A power source 7 comprising an internal combustion engine, for example a diesel engine, is mounted to the vehicle body. A mechanical drive 8 connects the power source 7 to the fluid pump 9 and a hydraulic pump 10 that is used to provide hydraulic system fluid pressure for the vehicle.

The fluid pump 9 comprises a pump housing 18 with three tangential fluid outlets 19 that are combined into a single fluid conduit 20. The single fluid conduit 20 is then split into left side 21 and right side 22 fluid conduits which connect at the front and rear of the vehicle to form a complete circuit. The fluid pump 9 is thus fluidically connected to all fluid nozzles of the vehicle via the fluid conduits 20-22.

A first fluid nozzle 11 is provided at a front of the vehicle. The first fluid nozzle 11 comprises first articulation means 12 that is hydraulically powered to cause the nozzle to change angular orientation relative to the vehicle body 1 in a vertical plane. A pair of second fluid nozzles 13 is provided at a rear of the vehicle. The second fluid nozzles 13 comprise a second articulation means 14 that is hydraulically powered to cause the nozzles to change angular orientation relative to the vehicle body 1 in a vertical plane. The first and second fluid nozzles are part of a plurality of fluid nozzles of the vehicle. The plurality of fluid nozzles further comprises side fluid nozzles 16, 17 on opposite sides of the vehicle. A pair of left side fluid nozzles 16 and a pair of right side fluid nozzles 17 are provided.

Valve structure comprising a valve 15 corresponding to each fluid nozzle 11, 13, 16, 17 is also provided. The valves 15 are powered and operable to open or close. The valves 15 may be opened fully or partially to proportion flow between the plurality of fluid nozzles. Cooperation between the

6

valves 15 and the plurality of fluid nozzles is used to provide directional control and motive power for the vehicle while floating. For example, proportioning fluid flow from the right side fluid nozzles 17 to the left side fluid nozzles 16 causes the vehicle to turn to the right while floating. Similarly, fluid flow may be proportioned between the first fluid nozzle 11 and the second fluid nozzles 13 to cause the vehicle to move forward or backward. By rotating the second fluid nozzles 13 fully downwardly and then up toward the front of the vehicle using the second articulation means 14, the vehicle may also be directed rearward and/or slowed in its forward movement speed. Thus, the combination of proportioning flow between the plurality of fluid nozzles using the valve structure and/or articulating the nozzles may be used to control forward, rearward, left and right movement and speed of the vehicle. The flow rate of the fluid pump 9 may also be adjusted to enhance directional and speed control via the plurality of nozzles while floating.

Referring additionally to FIG. 4, each wheel of the front set of wheels 3 is rotatably attached to its corresponding lever 5 by a spindle 23. Fixedly mounted to lever 5 is a bracket 24 supporting a pair of hydraulic motors 25. Each hydraulic motor 25 has an output gear (not shown) that is engaged with a drive gear 26. The drive gear 26 is fixedly attached to a rim 27 of each wheel 3 concentric with the spindle 23. Referring to the right side wheel of the set of wheels 3 (showing an interior of the rim 27), operation of the hydraulic motors 25 in a clockwise direction causes the drive gear 26 to rotate in a counterclockwise direction, moving the vehicle forward. Reversing the direction of operation of the hydraulic motors 25 causes the vehicle to move rearward. By increasing the rotational speed of the hydraulic motors 25 on the right side relative to the motors 25 on the left side, the vehicle is caused to turn to the left. The motors 25 connected to the rear set of wheels 4 work in a similar manner to those described for the front set of wheels 3. Thus, directional and motive control of the vehicle (forward/reverse) while on land is controlled by varying the relative speed and rotational direction of the hydraulic motors 25.

Turning now to FIG. 5, the first fluid nozzle 11 is able to change angular direction in a vertical plane relative to the vehicle body 1 through operation of a powered first articulation means 12. The first articulation means 12 comprises a hydraulic first articulation cylinder 28 that is coupled to a four bar linkage 29. The four bar linkage 29 serves to amplify the effective stroke length of the first articulation cylinder 28 to cause the nozzle to move through a larger degree of motion in the vertical plane than if the linkage 29 were not present. The first fluid nozzle 11 is connected to the fluid conduits 21, 22 via a flexible conduit 30 that permits articulation of the nozzle. Valves 15 are provided to proportion flow to the first fluid nozzle in a manner as described previously.

Referring to FIG. 6, the second fluid nozzles 13 are connected to the fluid conduits 21, 22 by articulation means 14 that comprises a hydraulic second articulation cylinder 31 mounted to the vehicle body 1 and connected to a rotatable conduit section 32. Actuation of the second articulation cylinder 31 causes the rotatable conduit section 32 to rotate relative to the first and second fluid conduits 21, 22. The second fluid nozzles 13 are provided on rotatable conduit section 32 and thus rotate with the conduit section 32 upon actuation of the articulation cylinder 31. This causes the nozzles 13 to change angular orientation relative to the vehicle body 1 in a vertical plane. The geometry of the second articulation cylinder 31 and the rotatable conduit

US 10,974,557 B2

7

section 32 is such that the nozzles 13 may be rotated fully downwardly and then upwardly towards the front of the vehicle. This allows an operator to change the amount of forward movement to slow or even reverse forward movement of the vehicle. When operated in conjunction with the valves 15, the nozzles 13 and second articulation structure 14 provide a high degree of control over forward and reverse movement of the vehicle.

Referring to FIG. 7, the power source 7 comprises an internal combustion engine connected to a mechanical drive 8 that delivers power to the pump 9 (not shown in FIG. 7) and also to the hydraulic pump 10 that is used to provide hydraulic fluid pressure to the vehicle's hydraulic systems. A transmission is provided within the mechanical drive 8 that allows the rotational speed of the fluid pump 9 to be adjusted independently of the rotational speed of the hydraulic pump 10. The power source 7 is thus mechanically connected to both the fluid pump 9 and the hydraulic pump 10.

Referring to FIG. 8, the fluid pump 9 comprises a pump housing 18 comprising three tangential fluid outlets 19 that are connected via flexible pump outlet conduits 33 to a combiner 34 that is used to combine the fluid output of the tangential fluid outlets 19 into the single conduit 20. A pump actuation cylinder 35 is provided to cause raising and lowering of the pump 9 and especially the pump housing 18 relative to the vehicle body 1. A telescoping pump support structure 36 is provided for use in combination with the pump actuation cylinder 35. A mechanical drive shaft (not shown) runs through the telescoping pump support structure 36 to provide power to the pump impeller 37. When powered, the impeller 37 draws the fluid to be pumped through an enlarged bottom fluid opening 38 of the pump housing 18. By immersing the pump housing 18 in the fluid, fluid is allowed to enter the pump housing, thereby obviating the need for priming the pump. Raising the pump 9 via the pump actuation cylinder 35 and telescoping pump support structure 36 allows the vehicle to exit the lagoon (or similar fluid reservoir) without damaging the pump. Thus, these structures cooperate with the ground engaging propulsion structure to allow the vehicle to operate on land.

An example of a pump 9 suitable for use with the vehicle is disclosed in co-pending U.S. patent application Ser. No. 13/038,189 filed Mar. 1, 2011, entitled Pump for Immersion Within a Fluid Reservoir, which is incorporated herein by reference.

The location of at least the ground engaging propulsion structure, the power source and the fluid pump are selected to provide a desired location for a center of gravity of the vehicle. The desired location for the center of gravity of the vehicle is selected to improve handling characteristics of the vehicle while floating. The center of gravity is located along the longitudinal centerline of the vehicle, substantially in the middle of the vehicle.

A remote control structure 40 comprises an antenna configured to cause the vehicle to be remotely controllable by an operator remote from the vehicle. The remote control structure comprises a wireless transmitter used by the operator and a wireless receiver on the vehicle. The wireless receiver interfaces with a hydraulic control center on the vehicle to permit control of hydraulically operated components, such as hydraulic cylinders, valves, motors, etc. This allows the operator to control vehicle speed and direction on land or when floating, to raise the wheels and to change the angular orientation of the first and second fluid nozzles. A wireless engine starter is provided to control operation of the internal combustion engine used as a power source. A set of

8

hydraulic controls is optionally provided to modulate engine speed and/or fluid pump rotational speed. Thus, a variety of functions may be controlled remotely that allow the vehicle to operate on land or when floating.

In operation, an operator uses the remote controls to maneuver the vehicle to the lagoon entrance, drive the vehicle into the lagoon, raise the ground engaging propulsion structure (wheels), lower the fluid pump, begin pumping fluid with the fluid pump through the fluid conduits and selectively open at least the second fluid nozzles to cause the vehicle to move out on to the surface of the lagoon. The valves associated with the side fluid nozzles may also be opened or closed to provide directional control of the vehicle on the lagoon. Once the vehicle is in the desired position, the valves associated with the first fluid nozzle are opened and the first articulation structure is used to position the first fluid nozzle at a desired angular orientation relative to the vehicle body. This is generally an upward orientation so that the fluid is sprayed widely to break crusts of material floating on the surface of the lagoon. In this manner, fluid is recirculated and directed to desired locations in the lagoon. As fluid is emptied from the lagoon, the floating vehicle is permitted to lower with the fluid level. When the lagoon has been sufficiently emptied, the operator is able to reverse the foregoing process in order to maneuver the vehicle to the lagoon exit, lower the wheels, and drive the vehicle up the muddy bank out of the lagoon.

The novel features will become apparent to those of skill in the art upon examination of the description. It should be understood, however, that the scope of the claims should not be limited by the embodiments, but are intended by the inventor to be given the broadest interpretation consistent with the wording of the claims and the specification as a whole.

The invention claimed is:

1. An amphibious vehicle comprising:

- a floatable vehicle body;
- ground engaging propulsion structure;
- a fluid pump for pumping liquid manure;
- at least one fluid nozzle connected by a fluid conduit to the fluid pump;
- a power source connected to a hydraulic pump and configured to provide power to both the ground engaging propulsion structure and the fluid pump; and,
- remote control structure configured to control the ground engaging propulsion structure and a flow of fluid from the fluid nozzle, wherein the speed and/or direction of the vehicle is remotely controllable by an operator remote from the vehicle when the vehicle is ground engaging and when the vehicle is floating.

2. The vehicle according to claim 1, wherein the ground engaging propulsion structure comprises a set of wheels or an endless track.

3. The vehicle according to claim 1, wherein the power source is configured to provide hydraulic fluid power to both the ground engaging propulsion structure and the fluid pump.

4. The vehicle according to claim 3, wherein the ground engaging propulsion structure is operable at variable speed by a hydraulic motor.

5. The vehicle according to claim 1, wherein the at least one fluid nozzle comprises a plurality of fluid nozzles connected to the fluid conduit.

6. The vehicle according to claim 1, wherein the location of the ground engaging propulsion structure, power source and fluid pump are selected to provide a desired location for a center of gravity of the vehicle.

US 10,974,557 B2

9

7. The vehicle according to claim 1, wherein the amount of fluid flow from the at least one fluid nozzle and/or the direction of the at least one fluid nozzle are remotely controllable by the operator remote from the vehicle when the vehicle is floating.

8. An amphibious vehicle comprising:
a floatable vehicle body;
four hydraulically powered ground engaging wheels;
four hydraulic motors, one hydraulic motor per wheel, for powering the four hydraulically powered ground engaging wheels;
a fluid pump for pumping liquid manure;
at least one directionally adjustable nozzle through which the liquid manure is pumped;
an internal combustion engine configured to provide power to both the four variable speed hydraulic motors and the fluid pump;
the location of the four hydraulically powered ground engaging wheels, the internal combustion engine and the fluid pump selected to provide a desired location for a center of gravity of the vehicle; and,
remote control structure configured to control the four variable speed hydraulic motors and the fluid pump,

10

wherein the speed and/or direction of the vehicle is remotely controllable by an operator remote from the vehicle when the vehicle is ground engaging and when the vehicle is floating.

5 9. The vehicle according to claim 8, wherein the power source is configured to provide hydraulic fluid power to the four hydraulic motors and the fluid pump.

10 10. The vehicle according to claim 9, wherein the four hydraulic motors are variable speed hydraulic motors and wherein the four hydraulically powered ground engaging wheels are each operable at variable speed.

15 11. The vehicle according to claim 8, wherein the at least one directionally adjustable nozzle is connected to a fluid conduit connected to the fluid pump.

20 12. The vehicle according to claim 11, wherein a plurality of nozzles comprising the at least one directionally adjustable nozzle is connected to the fluid conduit.

13. The vehicle according to claim 8, wherein the amount of fluid flow from the directionally adjustable nozzle and/or the direction of the directionally adjustable nozzle are remotely controllable by the operator remote from the vehicle when the vehicle is floating.

* * * * *

 **Tasch's Custom, LLC**
May 13, 2021 · 🌐



GAMECHANGER.BAZOOKAFARMSTAR.COM

The wait is over. Meet the highly anticipated, Wolverine Series agitation... [Learn more](#)

Bazooka Farmstar
May 13, 2021 · 🌐

The wait is over.

Meet the highly anticipated, Wolverine Series agitation boat. >>
<https://hubs.la/H0NfzNX0>

👍 4 1 Share

👍 Like 💬 Comment ➦ Share

 **Tasch's Custom, LLC**
July 14, 2021 · 🌐







Bazooka Farmstar
July 13, 2021 · 🌐



Attention, Wisconsinites!

We are headed to your state with none other than the Wolverine Series! Kick the tires at the [Wisconsin Farm Technology Days](#) next wee... [See more](#)

 3

 Like  Comment  Share

 **Tasch's Custom, LLC**
July 28, 2021 · 🌐



Bazooka Farmstar
July 28, 2021 · 🌐

Thank you everyone for coming out and kicking the tires with us at [Tasch's Custom, LLC's](#) Wolverine Series agitation boat demo yesterday afternoon.

We even had... [See more](#)

 19

 Like  Comment  Share

 **Tasch's Custom, LLC**
August 3, 2021 · 🌐

The Bazooka Farmstar toolbar and the 2 Full Throttle pump trailer's are delivered, and waiting for the start up tomorrow afternoon



👍 21 1 Share

👍 Like 💬 Comment ➦ Share



Tasch's Custom, LLC

August 19, 2021 · 🌐



Thank you Eisentraut Ag Service for your purchase of the new Bazooka Farmstar Wolverine Agitation Boat. It's sure doing a great job this morning.



👍 29

1 Share

👍 Like

💬 Comment

➦ Share



Tasch's Custom, LLC

September 8, 2021 · 🌐



Thank you to Jesse Dvorachek at Dvorachek Farm and Industry for purchasing their new Bazooka Farmstar Wolverine agitation boat from us.



👍 46

1 Share

👍 Like

💬 Comment

➦ Share



 **Tasch's Custom, LLC**
September 16, 2021 · 🌐







BLOG.BAZOOKAFARMSTAR.COM

NEW | High Performance Agitation Solutions

[Learn more](#)

 4  1 Share



 Like  Comment  Share



 **Tasch's Custom, LLC**
September 24, 2021 · 🌐



Bazooka Farmstar
September 24, 2021 · 🌐

Performance report:
The Wolverine Series went to work at an on-site demo last week. This pit typically takes 2 stick agitators running most of the day to break... [See more](#)

  5



 Like  Comment  Share

 **Tasch's Custom, LLC**
October 6, 2021 · 🌐

Thank you BHF Pumping for your purchase of your new Bazooka Farmstar Wolverine Agitation Boat. It is doing an excellent job



👍 23 1 Share

 Like  Comment  Share

 **Tasch's Custom, LLC**
October 27, 2021 · 🌐

Applying manure into cover crops today, with the Bazooka Farmstar 26' toolbar with Phantom Edge row units



34 2 Comments 5 Shares

 Like  Comment  Share

 **Tasch's Custom, LLC**
November 19, 2021 · 🌐

The Bazooka Farmstar Wolverine busting up a thick frozen crust



👍 🤯 13 1 Comment 1 Share

👍 Like 💬 Comment ➦ Share



 **Tasch's Custom, LLC**
December 31, 2021 at 12:04 PM · 🌐



BLOG.BAZOOKAFARMSTAR.COM

ICYMI: We've Introduced an Agitation Product Category to our Line-Up.

 3

 Like  Comment  Share

HASSE & NESBITT LLC
INTELLECTUAL PROPERTY & TECHNOLOGY LAW

Daniel F. Nesbitt †
Donald E. Hasse †
Ronald J. Richter †
Cheryl S. Scotney †
Daniel H. Lajiness †

8837 Chapel Square Drive, Suite C
Cincinnati, Ohio 45249, USA
Phone: 513-229-0383
Fax: 513-229-0683

† Licensed Attorneys in Ohio and
Registered Patent Attorneys

Sender's E-mail: dfn@hn-iplaw.com

April 14, 2021

Mr. Eric Hahn
Managing Partner (ehahn@bazookafarmstar.com)
Bazooka Farmstar, LLC
800 E. 7th Street
Washington, IA 52353

Dear Mr. Hahn:

My firm represents Nuhn Industries Ltd. ("Nuhn") of Sebringville, Ontario, with respect to its ownership and exclusive rights to the following United States Patents relating to amphibious vehicles for manure lagoons: U.S. Patent No. 9,694,636; U.S. Patent No. 10,124,638; U.S. Patent No. 10,710,422; U.S. Patent No. 10,974,557; and pending continuation patent application 17/201,100, filed on March 15, 2021 (collectively, "the Nuhn patent portfolio"). The Nuhn patent portfolio (including the pending continuation application) is the preeminent intellectual property in the U.S. for this inventive technology, marketed in the United States since 2013 under the Lagoon Crawler® trademark.

I attach for your convenience U.S. Patent 10,974,557, which issued yesterday, April 13, 2021. It has come to Nuhn's attention that Bazooka Farmstar LLC is planning to manufacture or is presently manufacturing, and intending to introduce to the market, an amphibious vehicle for manure lagoons. Nuhn has information that would indicate that the amphibious vehicle to be manufactured, used and/or sold by Bazooka Farmstar LLC may infringe one or more of the claims of Nuhn's just-issued U.S. Patent 10,974,557.

Nuhn intends to assert its valuable patent rights, including U.S. Patent 10,974,557, against any party who without authorization, makes, uses or sells an amphibious vehicle covered by one or more claims of the Nuhn patent portfolio, and shall reserve the right to bring prompt and determined legal action against any infringer for such unauthorized use of its exclusive rights and damages resulting therefrom, and any other recourse or remedy available under the law.

If Bazooka Farmstar LLC is making, using, offering for sale, or selling an amphibious vehicle that infringes any patent claim within the Nuhn patent portfolio, and specifically any patent claim of U.S. Patent 10,974,557, Nuhn demands that Bazooka Farmstar LLC immediately CEASE AND DESIST from manufacturing, using, offering for sale, and selling such vehicles.

I look forward to hearing from you.

Very truly yours,



Daniel F. Nesbitt

Enclosures

cc: Ian Nuhn (ian@nuhn.ca)
Phil Minino (pminino@bazookafarmstar.com)

Exhibit 3

Infringement of U.S. Patent No. 10,974,557 by the Wolverine Series Agitation Boat

An amphibious vehicle comprising:

- a floatable vehicle body;
- ground engaging propulsion structure;
- a fluid pump for pumping liquid manure;
- at least one fluid nozzle connected by a fluid conduit to the fluid pump;
- a power source connected to a hydraulic pump and configured to provide power to both the ground engaging propulsion structure and the fluid pump; and,
- remote control structure configured to control the ground engaging propulsion structure and a flow of fluid from the fluid nozzle, wherein the speed and/or direction of the vehicle is remotely controllable by an operator remote from the vehicle when the vehicle is ground engaging and when the vehicle is floating.



The Bazooka Website (bazookafarmstar.com) describes the Wolverine Series Agitation Boat as a "boat" that can enter a manure lagoon.

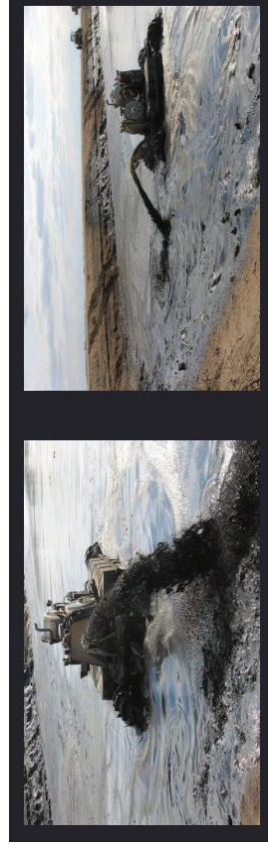

Exhibit 4

Infringement of U.S. Patent No. 10,974,557 by the Wolverine Series Agitation Boat

An amphibious vehicle comprising:

- a **floatable vehicle body**;
- ground engaging propulsion structure;
- a fluid pump for pumping liquid manure;
- at least one fluid nozzle connected by a fluid conduit to the fluid pump;
- a power source connected to a hydraulic pump and configured to provide power to both the ground engaging propulsion structure and the fluid pump; and,
- remote control structure configured to control the ground engaging propulsion structure and a flow of fluid from the fluid nozzle, wherein the speed and/or direction of the vehicle is remotely controllable by an operator remote from the vehicle when the vehicle is ground engaging and when the vehicle is floating.



Floats on the sides of the Wolverine Series Agitation Boat provide for a floatable vehicle body.

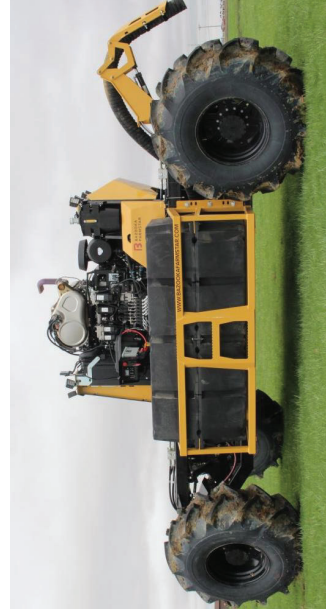

Source: <https://bazookafarmstar.com/wolverine-series/>;
https://bazookafarmstar.com/wp-content/uploads/2021/05/IMG_3695-cropped-1024x683.jpg

Infringement of U.S. Patent No. 10,974,557 by the Wolverine Series Agitation Boat

An amphibious vehicle comprising:

- a floatable vehicle body;
- ground engaging propulsion structure;**
- a fluid pump for pumping liquid manure;
- at least one fluid nozzle connected by a fluid conduit to the fluid pump;
- a power source connected to a hydraulic pump and configured to provide power to both the ground engaging propulsion structure and the fluid pump; and,
- remote control structure configured to control the ground engaging propulsion structure and a flow of fluid from the fluid nozzle, wherein the speed and/or direction of the vehicle is remotely controllable by an operator remote from the vehicle when the vehicle is ground engaging and when the vehicle is floating.



The Wolverine Series Agitation Boat has “large diameter, aggressive tires [that] make climbing out of steep banks effortless.”

DRIVE SYSTEM

- [4] Goodyear tires, 23.1-26, 12 ply [68" DIA x 24" wide]
- 4-wheel steering
 - Crab, front, and rear steering capabilities
- High-torque planetary wheel drives
- Double-acting steering cylinders

Infringement of U.S. Patent No. 10,974,557 by the Wolverine Series Agitation Boat

An amphibious vehicle comprising:

- a floatable vehicle body;
- ground engaging propulsion structure;
- a fluid pump for pumping liquid manure;**
- at least one fluid nozzle connected by a fluid conduit to the fluid pump;
- a power source connected to a hydraulic pump and configured to provide power to both the ground engaging propulsion structure and the fluid pump; and,
- remote control structure configured to control the ground engaging propulsion structure and a flow of fluid from the fluid nozzle, wherein the speed and/or direction of the vehicle is remotely controllable by an operator remote from the vehicle when the vehicle is ground engaging and when the vehicle is floating.



The Wolverine Series Agitation Boat includes a submersible pump for pumping the contents of a manure lagoon.



Source: <https://bazookafarmstar.com/wolverine-series/>
https://bazookafarmstar.com/wp-content/uploads/2021/05/IMG_4077-2-1024x683.jpg

Infringement of U.S. Patent No. 10,974,557 by the Wolverine Series Agitation Boat

An amphibious vehicle comprising:

- a floatable vehicle body;
- ground engaging propulsion structure;
- a fluid pump for pumping liquid manure;
- at least one fluid nozzle connected by a fluid conduit to the fluid pump;
- a power source connected to a hydraulic pump and configured to provide power to both the ground engaging propulsion structure and the fluid pump; and,
- remote control structure configured to control the ground engaging propulsion structure and a flow of fluid from the fluid nozzle, wherein the speed and/or direction of the vehicle is remotely controllable by an operator remote from the vehicle when the vehicle is ground engaging and when the vehicle is floating.



The Wolverine Series Agitation Boat includes a fluid nozzle connected by a fluid conduit to the fluid pump.

SUBMERSIBLE PUMP

- 18" Bazooka Submersible Pump | 4,000+ GPM
 - Dual, 6" plumbing into a single, 8" discharge
 - Dual-port outlets provide next-level efficiency
 - 5-blade impeller constructed with Hardox steel



Infringement of U.S. Patent No. 10,974,557 by the Wolverine Series Agitation Boat

- An amphibious vehicle comprising:
 - a floatable vehicle body;
 - ground engaging propulsion structure;
 - a fluid pump for pumping liquid manure;
 - at least one fluid nozzle connected by a fluid conduit to the fluid pump;
 - a power source connected to a hydraulic pump and configured to provide power to both the ground engaging propulsion structure and the fluid pump;** and,

remote control structure configured to control the ground engaging propulsion structure and a flow of fluid from the fluid nozzle, wherein the speed and/or direction of the vehicle is remotely controllable by an operator remote from the vehicle when the vehicle is ground engaging and when the vehicle is floating.

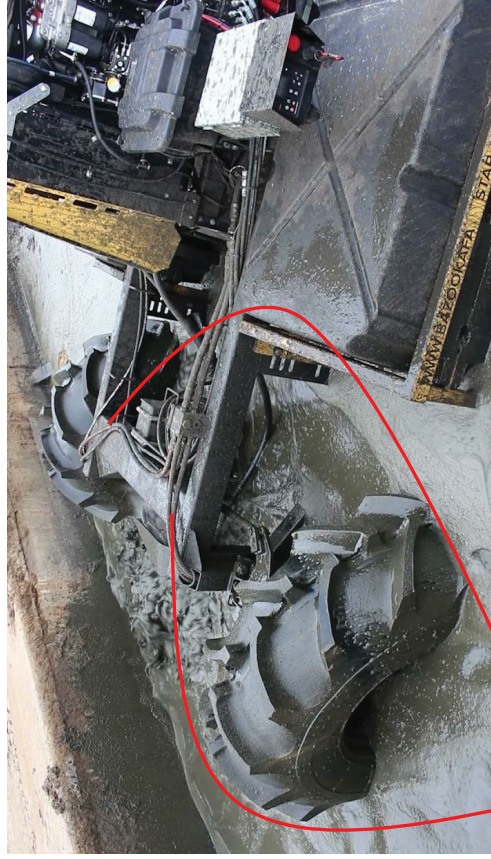

The Wolverine Series Agitation Boat includes a power source configured to provide power to the tires (via hydraulic lines) and the fluid pump. The power source (engine) is connected to a hydraulic pump.

ENGINE	<ul style="list-style-type: none"> Perkins 71 L 302 HP, Tier 4 Final <ul style="list-style-type: none"> 15 gal/hr. fuel consumption rate at full load
HYDRAULIC SYSTEM	<ul style="list-style-type: none"> Dual hydrostat Linde piston pumps 20-gallon Cyclone hydraulic oil tank <ul style="list-style-type: none"> 18 gallons are required for entire system 8 hydraulic cylinders 8 hydraulic valves

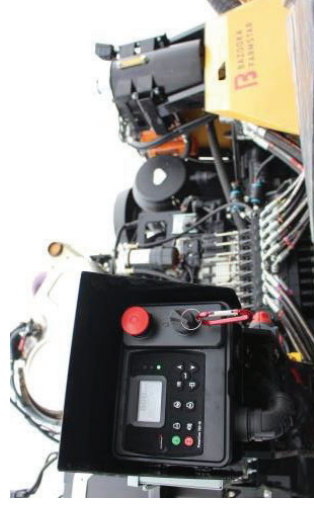

Source: https://bazookafarmstar.com/wp-content/uploads/2021/04/IMG_3689-500x305.jpg;
<https://i.ytimg.com/vi/Md8vlz5v15k/maxresdefault.jpg>; <https://bazookafarmstar.com/wolverine-series/>

Infringement of U.S. Patent No. 10,974,557 by the Wolverine Series Agitation Boat

An amphibious vehicle comprising:

- a floatable vehicle body;
- ground engaging propulsion structure;
- a fluid pump for pumping liquid manure;
- at least one fluid nozzle connected by a fluid conduit to the fluid pump;
- a power source connected to a hydraulic pump and configured to provide power to both the ground engaging propulsion structure and the fluid pump; and,
- remote control structure configured to control the ground engaging propulsion structure and a flow of fluid from the fluid nozzle**, wherein the speed and/or direction of the vehicle is remotely controllable by an operator remote from the vehicle when the vehicle is ground engaging and when the vehicle is floating.



The Wolverine Series Agitation Boat includes a remote control structure that controls both the tires and the flow from the fluid nozzle.



Infringement of U.S. Patent No. 10,974,557 by the Wolverine Series Agitation Boat

An amphibious vehicle comprising:

- a floatable vehicle body;
- ground engaging propulsion structure;
- a fluid pump for pumping liquid manure;
- at least one fluid nozzle connected by a fluid conduit to the fluid pump;
- a power source connected to a hydraulic pump and configured to provide power to both the ground engaging propulsion structure and the fluid pump; and,
- remote control structure configured to control the ground engaging propulsion structure and a flow of fluid from the fluid nozzle, **wherein the speed and/or direction of the vehicle is remotely controllable by an operator remote from the vehicle when the vehicle is ground engaging and when the vehicle is floating.**



The Wolverine Series Agitation Boat includes a remote control structure that controls the speed and/or direction of the vehicle when it is ground engaging and when it is floating.

