

**UNITED STATES DISTRICT COURT
FOR THE NORTHERN DISTRICT OF TEXAS
DALLAS DIVISION**

ROSEN TECHNOLOGIES LLC,

Plaintiff,

v.

LENNOX INDUSTRIES INC.,

Defendant.

Case No. 3:22-cv-732

**COMPLAINT FOR PATENT
INFRINGEMENT**

JURY TRIAL DEMANDED

COMPLAINT FOR PATENT INFRINGEMENT

Plaintiff Rosen Technologies LLC (“Rosen” or “Plaintiff”) hereby asserts the following claims for patent infringement against Defendant Lennox Industries Inc. (“Lennox” or “Defendant”), and alleges as follows:

SUMMARY

1. Rosen owns by assignment all right, title and interest in numerous United States and foreign patents and applications including United States Patent Nos. 6,581,846; 6,619,555; 6,789,739; 7,156,318; 7,185,825; and 7,232,075 (“Asserted Patents”).

2. Defendant infringes the Asserted Patents by at least selling, without authorization, Rosen’s proprietary technologies in a number of its products including the Lennox iComfort Wi-Fi Thermostat, and other substantially similar products (collectively, the “Accused Products”). These Accused Products are marketed, offered, and distributed throughout the United States, including in this District.

3. By this action, Rosen seeks to obtain compensation for the harm it has suffered as a result of Defendant’s infringement of the Asserted Patents.

NATURE OF THE ACTION

4. This is a civil action for patent infringement arising under the patent laws of the United States, 35 U.S.C. § 1 *et seq.*

5. Defendant has infringed and continues to infringe, and at least as early as the filing and/or service of this Complaint, has induced and continues to induce infringement of, and has contributed to and continues to contribute to infringement of, one or more claims of Rosen's Asserted Patents at least by making, using, selling, and/or offering to sell its products and services in the United States, including in this District, and/or by importing the Accused Products into the United States.

6. Rosen is the legal owner by assignment of the Asserted Patents, which were duly and legally issued by the United States Patent and Trademark Office ("USPTO"). Rosen seeks monetary damages for Defendant's infringement of the Asserted Patents.

THE PARTIES

7. Plaintiff Rosen Technologies LLC is a Texas limited liability company with its principal place of business at 17330 Preston Road, Suite 200D, Dallas, Texas 75252. Rosen is the owner of intellectual property rights at issue in this action.

8. On information and belief, Defendant Lennox is a corporation organized and existing under the laws of Delaware, with a place of business at 2100 Lake Park Blvd., Richardson, TX 75080. Lennox may be served via its registered agent, Corporation Service Company, 251 Little Falls Drive, Wilmington, DE, 19808.

9. On information and belief, Defendant directly and/or indirectly develops, designs, manufactures, distributes, markets, offers to sell and/or sells infringing products and services in the United States, including in the Northern District of Texas, and otherwise directs infringing

activities to this District in connection with its products and services.

JURISDICTION AND VENUE

10. As this is a civil action for patent infringement arising under the patent laws of the United States, 35 U.S.C. § 1 *et seq.*, this Court has subject matter jurisdiction over the matters asserted herein under 28 U.S.C. §§ 1331 and 1338(a).

11. This Court has personal jurisdiction over Defendant, in part because Defendant does continuous and systematic business in this District, including by providing infringing products and services to the residents of the Northern District of Texas that Defendant knew would be used within this District, and by soliciting business from the residents of the Northern District of Texas. For example, Defendant is subject to personal jurisdiction in this Court because, *inter alia*, Defendant has a regular place of business in the district, and directly and through agents regularly does, solicits, and transacts business in the Northern District of Texas.

12. In particular, Defendant has committed and continues to commit acts of infringement in violation of 35 U.S.C. § 271, and has made, used, marketed, distributed, offered for sale, sold, and/or imported infringing products in the State of Texas, and engaged in infringing conduct within and directed at or from this District. For example, Defendant has purposefully and voluntarily placed the Accused Products into the stream of commerce with the expectation that the Accused Products will be used in this District. The Accused Products have been and continue to be distributed to and used in this District. Defendant's acts cause and have caused injury to Rosen, including within this District.

13. Venue is proper in this District under the provisions of 28 U.S.C. § 1400(b) at least because Defendant has committed acts of infringement in this District and has a regular and established place of business in this District at 2100 Lake Park Blvd., Richardson, TX 75080.

PATENTS-IN-SUIT

14. The Asserted Patents stem from inventions from Howard Rosen. Mr. Rosen has been a dedicated Inventor in the field of electronics for decades. In 1977, he created the first solid state radio frequency epilation equipment.

15. In 1982, Mr. Rosen developed many improvements to the home satellite TV market including the block-down frequency converter to allow for multiple receiver/program viewing from one satellite to a plurality of satellite home receivers.

16. In 1994, Mr. Rosen continued work in communications by inventing automatic caller-id phone number blocking which was represented by U.S. Patent No. 5,309,508 which was subsequently acquired by Motorola.

17. In 1998, among other things, Mr. Rosen developed computerized automatic telephone recorders as well as diagnostic tools for accessing the efficacy of the optic nerve after laser treatment. Mr. Rosen has been referred to many times at trade shows by many peers and companies as a prolific inventor.

18. Around 1999, Mr. Rosen recognized a large void in the thermostat market and a definite need to make thermostats and their controls more user friendly. In or around 2000, he began filing patents on methods for making thermostats with touchscreens which were more intuitive and user friendly and he continued by additionally adding features which would turn out to help make homes more comfortable, efficient, and informative by acting on external stimulus. Further, the thermostats would incorporate more information and display important messages on a thermostat screen while maintaining the principle of user friendliness in working with virtual touchscreen thermostats which would subliminally teach a user how to control the HVAC system in a complex way without any burden on the user.

19. Mr. Rosen developed thermostats that could change their user interface to adapt to the HVAC systems specifically in a particular equipment environment. AED Electronics Inc., owned by Mr. Rosen, set out to make headways into the HVAC market at the turn of the century.

20. AED Electronics thermostats were beginning to be produced by AED Electronics and were marketed under the OEM names of Carrier Corporation such as “Totaline” as well as private labeling for other companies. Most of the AED products included dot matrix liquid crystal displays similar to the way today’s LCD television screen work with dots and the ability to have a virtual touchscreen thermostat allowed thermostat screen greatly improved user interface which could even include changes in contrast and look to accommodate for décor and dark rooms. The list of improvements in the thermostat field that developed by Mr. Rosen, were vast and covered multiple options for user screens including but not limited to making buttons that were only necessary to the user appear on each individual thermostat thus eliminating unused buttons which was the old conventional way of developing thermostats.

21. In 2004, Mr. Rosen developed a remote wireless device that included a temperature sensor and an occupancy sensor that could be placed in many rooms in a building or home so that a thermostat would control temperature more accurately in occupied rooms in commercial buildings or homes.

22. At that point, Mr. Rosen created a company, Verdant Environmental Technologies, which used various methods to wirelessly control large building energy consumption and reduce electrical and fossil fuel demand by as much as 48%. The results were more successful than anyone dreamed of and as a result within approximately 8 years the company was sold to a large multinational group and evolved into products today manufactured as a subsidiary under Emerson Electric.

23. Mr. Rosen's contributions to the technology now incorporated into today's HVAC systems are immeasurable.

U.S. Patent No. 6,581,846

24. U.S. Patent No. 6,581,846 ("the '846 Patent") is entitled "Thermostat including a vacation mode in which electrical devices within and proximate the conditioned space are operated by the thermostat to provide an occupied appearance," and was issued on June 24, 2003. A true and correct copy of the '846 Patent is attached as Exhibit A.

25. The '846 Patent was filed on March 6, 2002, as U.S. Patent Application No. 10/091,757.

26. Rosen is the owner of all rights, title, and interest in and to the '846 Patent, with the full and exclusive right to bring suit to enforce the '846 Patent, including the right to recover for past infringement.

27. The '846 Patent is valid and enforceable under United States Patent Laws.

28. The '846 Patent recognized several problems with existing thermostats with a "vacation" mode of operation, wherein third parties may notice that the homeowner is away from the residence. Exhibit A at 1:11-20.

29. To address one or more shortcomings of these existing microcontrollers, the '836 Patent discloses the ability for the thermostat "when operating in 'vacation' mode, issues commands to various devices situated in and around the conditioned space to provide an appearance of ongoing occupancy." *Id.* at 1:15-20. This is performed by the system "issu[ing]" a pattern of actuate and deactuate commands to the addressable electrical devices to provide the illusion of ongoing occupancy." *Id.*, 2:18-22

U.S. Patent No. 6,619,555

30. U.S. Patent No. 6,619,555 (“the ’555 Patent”) is entitled “Thermostat System Communicating With A Remote Correspondent For Receiving And Displaying Diverse Information,” and was issued on September 16, 2003. A true and correct copy of the ’555 Patent is attached as Exhibit B.

31. The ’555 Patent was filed on February 13, 2002, as U.S. Patent Application No. 10/075,886.

32. Rosen is the owner of all rights, title, and interest in and to the ’555 Patent, with the full and exclusive right to bring suit to enforce the ’555 Patent, including the right to recover for past infringement.

33. The ’555 Patent is valid and enforceable under United States Patent Laws.

34. The ’555 Patent recognized several problems with existing programmable and non-programmable thermostat systems. Exhibit B at 1:48-64. Specifically, in the prior art, “thermostat systems are [either] programmable by a user” or “may limit, or even make no provision for, user programming... [such as] thermostats distributed throughout a large commercial establishment.” *Id.*

35. To address one or more shortcomings of these existing thermostats, the ’555 Patent discloses, *inter alia*, a “thermostat system incorporating a communication interface for receiving and displaying diverse information from a remote correspondent.” *Id.* at 1:8-10.

U.S. Patent No. 6,789,739

36. U.S. Patent No. 6,789,739 (“the ’739 Patent”) is entitled “Thermostat System With Location Data,” and was issued on September 14, 2004. A true and correct copy of the ’739 Patent is attached as Exhibit C.

37. The '739 Patent was filed on November 4, 2002, as U.S. Patent Application No. 10/287,677.

38. Rosen is the owner of all rights, title, and interest in and to the '739 Patent, with the full and exclusive right to bring suit to enforce the '739 Patent, including the right to recover for past infringement.

39. The '739 Patent is valid and enforceable under United States Patent Laws.

40. The '739 Patent recognized several problems with existing thermostat systems. Exhibit C at 1:48-64. Specifically, in the prior art solution, “thermostat systems are [either] programmable by a user” or “may limit, or even make no provision for, user programming... [such as] thermostats distributed throughout a large commercial establishment.” *Id.*

41. To address one or more shortcomings of these existing thermostats, the '739 Patent discloses, *inter alia*, a “thermostat system incorporating a communication interface for receiving and displaying diverse information from a remote correspondent.” *Id.* at 1:9-11.

U.S. Patent No. 7,156,318

42. U.S. Patent No. 7,156,318 (“the '318 Patent”) is entitled “Programmable Thermostat Incorporating A Liquid Crystal Display Selectively Presenting Adaptable System Menus Including Changeable Interactive Virtual Buttons,” and was issued on January 2, 2007. A true and correct copy of the '318 Patent is attached as Exhibit D.

43. The '318 Patent was filed on September 3, 2003, as U.S. Patent Application No. 10/654,235.

44. Rosen is the owner of all rights, title, and interest in and to the '318 Patent, with the full and exclusive right to bring suit to enforce the '318 Patent, including the right to recover for past infringement.

45. The '318 Patent is valid and enforceable under United States Patent Laws.

46. The '318 Patent recognized several problems with existing programmable thermostats. Exhibit D at 1:65-2:9. Specifically, in the prior art solution, “[t]here is a fundamental problem with the prior art programmable thermostat systems: they are difficult to program to the extent that some users are unable to successfully program them. This is because the user interfaces which have been employed in prior art programmable interfaces are not highly intuitive.” *Id.* at 2:10-15. Furthermore, the prior art relied on “fixed position real or virtual buttons, at least some of which have multi-functions depending upon the point which a user has reached in the programming process.” *Id.* at 2:15-20.

47. To address one or more shortcomings of these existing thermostats, the '318 Patent discloses, *inter alia*, “a field programmable thermostat which may be user-configured to limit functionality only as necessary for the specific conditioned space for which the program is being established.” *Id.* at 3:1-5.

U.S. Patent No. 7,185,825

48. U.S. Patent No. 7,185,825 (“the '825 Patent”) is entitled “Programmable Thermostat Employing A Fail Safe Real Time Clock,” and was issued on March 6, 2007. A true and correct copy of the '825 Patent is attached as Exhibit E.

49. The '825 Patent was filed on June 24, 2004, as U.S. Patent Application No. 10/875,579.

50. Rosen is the owner of all rights, title, and interest in and to the '825 Patent, with the full and exclusive right to bring suit to enforce the '825 Patent, including the right to recover for past infringement.

51. The '825 Patent is valid and enforceable under United States Patent Laws.

52. The '825 Patent recognized several problems with existing thermostat systems. Exhibit E at 2:10-55. Specifically, in the prior art, “power to a programmable thermostat is supplied from the controlled space conditioning equipment, and either a battery or very high capacity capacitor ('super-cap') provides backup power to 'ride out' equipment power failure ('outage') until power is restored” *Id.* at 2:18-22. Furthermore, “[b]atteries must be changed at intervals to ensure that the thermostat will continue to hold its time and setting throughout an outage.” *Id.* at 2:22-25.

53. To address one or more shortcomings of these existing thermostats, the '825 Patent discloses, *inter alia*, a “a fail safe real time clock in a programmable clock, particularly a thermostat incorporating a vacation mode of operation.” *Id.* at 2:56-59.

U.S. Patent No. 7,232,075

54. U.S. Patent No. 7,232,075 (“the '075 Patent”) is entitled “Thermostat System With Touchscreen With User Interfaces Or Operational Algorithms Via A Remote Correspondent” and was issued on June 19, 2007. A true and correct copy of the '075 Patent is attached as Exhibit F.

55. The '075 Patent was filed on January 19, 2005, as U.S. Patent Application No. 11/039,180.

56. Rosen is the owner of all rights, title, and interest in and to the '075 Patent, with the full and exclusive right to bring suit to enforce the '075 Patent, including the right to recover for past infringement.

57. The '075 Patent is valid and enforceable under United States Patent Laws.

58. The '075 Patent recognized several problems with existing thermostat systems. Exhibit F at 1:34-3:4. Specifically, in the prior art “information or operational interfaces of

programmable thermostats can be incomprehensible or overly challenging to many users with advanced age, learning skills, poor vision and others in similar circumstances”. *Id.* at 2:27-30. In the prior art, “user interface that use a mixture of raised push buttons with representations of environmental sensor information and control data on a segmented liquid crystal display.” *Id.* at 2:35-38. The ’075 Patent provides a solution to the prior art problems where “thermostat systems are [either] programmable by a user” or “may limit, or even make no provision for, user programming... [such as] thermostats distributed throughout a large commercial establishment.” *Id.*

59. To address one or more shortcomings of these existing thermostats, the ’075 Patent discloses, *inter alia*, a thermostat “whose user interface can be easily changed after installation to accommodate equipment or control options not anticipated at installation or to change the user interface to a form not possible with a control program originally installed with the thermostat.” *Id.* at 3:5-10.

COUNT I: INFRINGEMENT OF U.S. PATENT NO. 6,581,846

60. Rosen incorporates by reference and re-alleges paragraphs 1-59 of this Complaint as if fully set forth herein.

61. Defendant has infringed and is infringing, either literally or under the doctrine of equivalents, the ’846 Patent in violation of 35 U.S.C. § 271 *et seq.*, directly and/or indirectly, by making, using, offering for sale, or selling in the United States, and/or importing into the United States without authority or license, the Lennox iComfort Wi-Fi Thermostat, and other substantially similar products (“’846 Accused Products”)

62. As just one non-limiting example, set forth below (with claim language in bold and italics) is exemplary evidence of infringement of Claim 1 of the ’846 Patent in connection

with the '846 Accused Products. This description is based on publicly available information. Rosen reserves the right to modify this description, including, for example, on the basis of information about the '846 Accused Products that it obtains during discovery.

1) A thermostat system for controlling space conditioning equipment comprising: - For instance, the '846 Accused Product is a thermostat system.

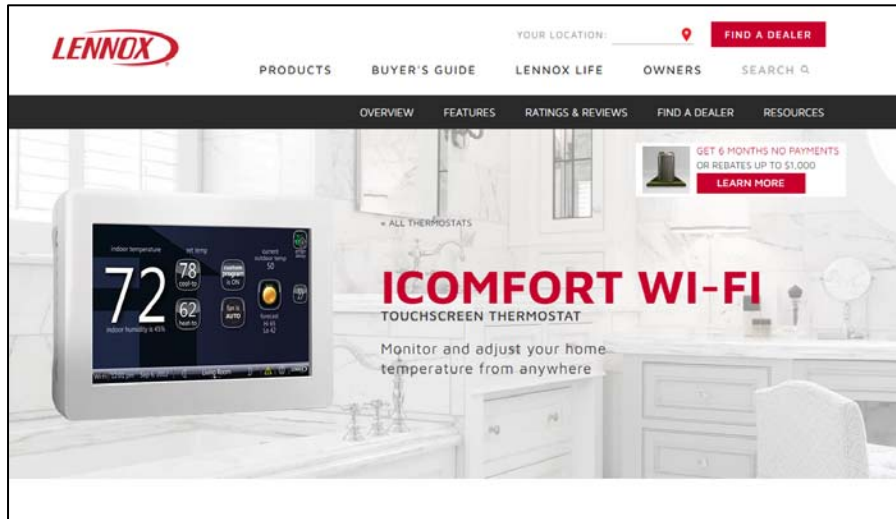

This thermostat supports:

- Wireless bands 802.11b, 802.11g and 802.11n
- Three languages (English, French, Spanish)
- Air conditioning or heat pump units with up to four stages of heat / two stages of compressor operation (2 stages of heat pump heating, 2 stages of auxiliary back-up heating and 2 stages of emergency heating)
- Variable-capacity / multiple-stage heat / cool and universal compatibility (gas/electric/heat pump/air conditioner).
- Dual-fuel capable (iComfort®-enabled HP only) with two balance points.
- Indoor air quality with time-based notification of consumables including media filters, UVC bulbs, humidifier pads and PureAir™ system catalyst service / replacement,
- iHarmony® Zoning System (2 - 4 zones)
- Lennox iComfort® Equipment Interface Module (Catalog number 10T50) (provides iComfort Wi-Fi® to non-communicating indoor unit,
- Humidification measurement and control.
- Dew point adjustment control
- Humiditrol® Enhanced Dehumidification Accessory (EDA)
- Multiple-stage HVAC systems
- Equipment maintenance reminders
- Autochangeover mode -- Permits control of heating, cooling, humidification, and dehumidification without user involvement
- All Lennox branded communicating outdoor units contain a built-in outdoor temperature sensor.

1A) a temperature sensor for providing an electrical signal indicative of the

temperature of a conditioned space in which the temperature sensor is situated;— For instance, the '846 Accused Product comes with a built-in temperature sensor, which senses the temperature of the conditioned space and sends a signal indicative of the temperature to the processor of thermostat.

29	Critical	(Thermostat) The thermostat is reading an indoor temperature that is higher than 99°F. The thermostat will not allow any heating operation to begin until it senses a temperature lower than 99°F.	Indoor temperature rose above 99°F during a heating or cooling demand. Heating operation is not allowed. Check to ensure that Heating Equipment is not stuck ON (reversing valve, etc.). Check the accuracy of the thermostat temperature sensor. Select cooling system mode to cool the indoor space.
30	Moderate	(Thermostat) The thermostat is reading an indoor temperature that is lower than 40°F. The thermostat will not allow any cooling operation to begin until it senses a temperature higher than 40°F.	Indoor Temp fell below 40°F. Cooling operation is not allowed. Check to ensure that cooling equipment is not stuck ON. Check accuracy of the thermostat temperature sensor. Select heating system mode to heat the indoor space to above 40°F.

1(B): a processor, said processor including;— For instance, the '846 Accused Products includes a processor; further including.

1(B)(1): a central processing unit;—For instance, the '846 Accused Products includes a central processing unit.

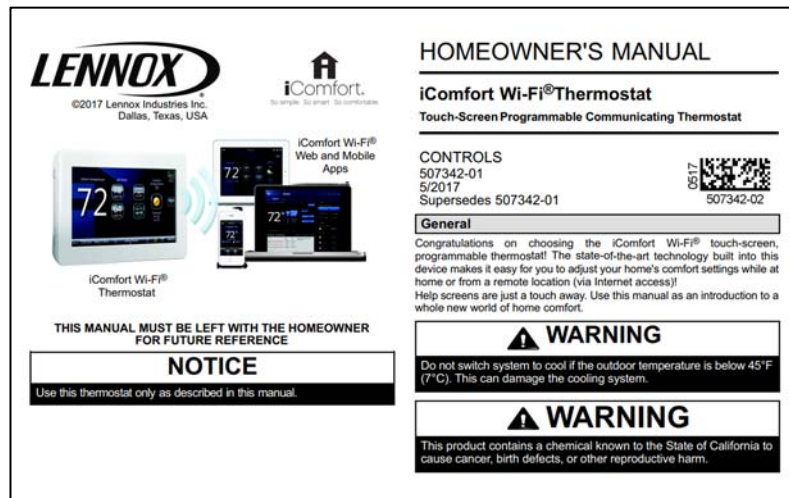

1(B)(2): a memory coupled to said central processing unit for storing program and data information; and;— For instance, the '846 Accused Products includes a memory coupled to the CPU.

 WARNING
<p>This is a 24VAC Class 2 thermostat. Do not install on voltages higher than 30VAC.</p> <p>Do not switch system to cool if the outdoor temperature is below 45°F (7°C). This can damage the cooling system.</p>
<p>iComfort Wi-Fi® Thermostat - Technical Description and Features</p>
<p>The 24VAC iComfort Wi-Fi® thermostat is an electronic communicating, color display touchscreen and 7-day programmable thermostat. It stores system parameters and settings in non-volatile memory (i.e., it retains data when electrical power fails or is turned off).</p> <p>The iComfort Wi-Fi® thermostat can connect to online services via the Internet through the homeowner's Wi-Fi access point. After online registration is completed, the system may then be accessed by the homeowner from anywhere using a remote Internet connection via computer or personal communicating device.</p> <p>Refer to page 37 for information on making connections to the thermostat.</p>

I(B)(3): an input/output unit including - For instance, the '846 Accused Products includes I/O ports for information transmission and reception.

- This thermostat supports:
- Wireless bands 802.11b, 802.11g and 802.11n
 - Three languages (English, French, Spanish)
 - Air conditioning or heat pump units with up to four stages of heat / two stages of compressor operation (2 stages of heat pump heating, 2 stages of auxiliary back-up heating and 2 stages of emergency heating)
 - Variable-capacity / multiple-stage heat / cool and universal compatibility (gas/electric/heat pump/air conditioner).
 - Dual-fuel capable (iComfort®-enabled HP only) with two balance points.
 - Indoor air quality with time-based notification of consumables including media filters, UVC bulbs, humidifier pads and PureAir™ system catalyst service / replacement,
 - iHarmony® Zoning System (2 - 4 zones)
 - Lennox iComfort® Equipment Interface Module (Catalog number 10T50) (provides iComfort Wi-Fi® to non-communicating indoor unit,
 - Humidification measurement and control.
 - Dew point adjustment control
 - Humiditrol® Enhanced Dehumidification Accessory (EDA)
 - Multiple-stage HVAC systems
 - Equipment maintenance reminders
 - Autochangeover mode -- Permits control of heating, cooling, humidification, and dehumidification without user involvement
 - All Lennox branded communicating outdoor units contain a built-in outdoor temperature sensor.

Figure 13. Registration Screen

NOTE - This following information is customer setup instructions and is shown here to allow the installer to help walk the customer through the setup process.

After registering through your iComfort Wi-Fi® thermostat interface, go to the homeowner's computer and locate the email sent from the server.

NOTE - If the customer has already setup an account, click the "Click Here" button to access that account.

Click on the Register link; the screen (to the left) will appear. Fill in the User Name and Password fields and check the agree to terms and conditions box. Click **Create User** button.

507341-02 12

Adding Non-Communicating Outdoor Unit and Accessories

OUTDOOR UNIT (AIR CONDITIONER OR HEAT PUMP)

To add (or remove) an outdoor unit that is not iComfort®-enabled, you must be at the "Add or Remove Non-communicating equipment?" screen.

1. Touch the **yes** button next to **Add or Remove Non-communicating equipment?**
2. In the "non-communicating device list" screen, use the arrows to highlight **Outdoor Unit Type** and touch **edit**.
3. Touch one of the radio buttons to select a 1-or 2-stage air conditioner unit or a 1-or 2-stage heat pump unit; touch **save**.
4. Use arrows to highlight any red colored text in the device list (e.g. select **Outdoor Unit Capacity**; text turns white). Touch **edit**.

5. Use either the up or down arrows to display the correct size outdoor unit. Touch **save** to continue.

NOTE - If the defaults are correct, you do not have to make any changes, but you must touch save. When all red text is gone, the back button will appear; touch it to return to the "Add or Remove Non-communicating equipment?" screen.

ADDING A HUMIDIFIER

Before adding a humidifier, be sure that the:

- Humidifier is wired to the furnace or air handler control as shown on the Optional Accessories wiring diagram (see page 42).
- Entire system is wired, powered up, and the thermostat has detected the system's installed communicating devices, and you are at the "Add or Remove Non-communicating equipment?" screen.

To add (or remove) a humidifier:

1. Touch the **yes** button on this screen.
2. In the "non-communicating device list" screen, use the arrows to highlight **Humidifier** (note the current value, **Not Installed**) and touch **edit**.
3. Touch one of the radio buttons to select the type of humidifier (or select **Not Installed**, if removing humidifier); touch **save**.
4. The previous screen returns, but the current value now shows your selection. Touch the **back** button.
5. The "Add or Remove..." screen reappears with your addition shown in the system devices list. At this point, you may add more equipment (touch **yes**) or if finished, touch the **next** button to advance to the "Adjust a setting..." screen (see page 15).

NOTE - Adding humidity regulating non-communicating devices may be a 2-step procedure:

- **First** the device must be installed and wired. After the humidifier is installed, the setting under the "System" mode "Humidification Control Mode" defaults to "Basic".
- **Second**, if you want another mode, i.e. Precision, Basic Dew Point, or Precision Dew Point, the device requires further configuration (see page 15).

ADDING HUMIDITROL® OR AN AUXILIARY DEHUMIDIFIER

Before adding a dehumidifier, be sure that:

- the dehumidifier is wired to the furnace or air handler control as shown on the Optional Accessories wiring diagram (see page 42).
- the entire system is wired, powered up, and the thermostat has detected the system's installed communicating devices, and you are at the "Add or Remove Non-communicating equipment?" screen.

To add (or remove) a dehumidifier, you must be at the "Add or Remove Non-communicating equipment?" screen.

1. Touch the **yes** button on this screen.
2. In the "non-communicating device list" screen, use the arrows to highlight **Dehumidifier** and touch **edit**. Note the current value (e.g. Not Installed).
3. Touch one of the radio buttons to select the type of dehumidifier (or select **Not Installed**, if removing dehumidifier); touch **save**.
4. When you scroll to the Dehumidifier device, (Note the current value, e.g. Humiditrol.) Click **back** to return to the "Add or Remove..." screen.
5. The "Add or Remove..." screen reappears with your addition shown in the system devices list. At this point, you may add more equipment (touch **yes**) or if finished, touch the **next** button to advance to the "Adjust a setting..." screen.

NOTE - Adding humidity regulating non-communicating devices may be a 2-step procedure:

- **First** the device must be installed and wired. After the dehumidifier is installed, the setting under the "System" mode "Dehumidification Control Mode" defaults to "Basic".
- **Second**, set Humiditrol® comfort adjust overcooling and the min/max dehumidification setpoints if desired (see page 16).

While iComfort Wi-Fi is designed for use with premium Lennox® equipment, the iComfort Wi-Fi Flex can work with almost any system. So no matter what type of home heating and cooling equipment you have, you can enjoy the innovation of Lennox, and a more comfortable, energy-efficient home.



	iComfort Wi-Fi®	iComfort Wi-Fi® Flex
Compatible with Lennox®-brand communicating heating and cooling equipment	•	
Compatible with Lennox-brand non-communicating equipment and most other brands of heating and cooling equipment		•
Touchscreen Operation	•	•
Remote Access	•	•
7-Day Programmable	•	•
One-Touch Away	•	•
5-Day Weather Forecast	•	•
Customizable Reminders	•	•
Automatic Updates	•	•
Dual-Fuel Compatible	•	•
Humidity Control	•	•
Diagnostics and Alerts	Highly Advanced	Limited Reporting
Compatible with zoned systems	Designed for integration with iHarmony® Zoning System	
Exchanges information with heating and cooling equipment	Uses Lennox Precise Comfort® Technology to optimize system performance	
Warranty	5-Year Limited	5-Year Limited

1(B)(3)(a): a sensor input coupled to said temperature sensor for receiving said electrical signal therefrom- For instance, the '846 Accused Products includes a built-in temperature sensor, which senses the temperature around and sends a signal indicative of the

temperature to the processor of thermostat. Also, it receives temperatures from its built-in sensor.

29	Critical	(Thermostat) The thermostat is reading an indoor temperature that is higher than 99°F. The thermostat will not allow any heating operation to begin until it senses a temperature lower than 99°F.	Indoor temperature rose above 99°F during a heating or cooling demand. Heating operation is not allowed. Check to ensure that Heating Equipment is not stuck ON (reversing valve, etc.). Check the accuracy of the thermostat temperature sensor. Select cooling system mode to cool the indoor space.
30	Moderate	(Thermostat) The thermostat is reading an indoor temperature that is lower than 40°F. The thermostat will not allow any cooling operation to begin until it senses a temperature higher than 40°F.	Indoor Temp fell below 40°F. Cooling operation is not allowed. Check to ensure that cooling equipment is not stuck ON. Check accuracy of the thermostat temperature sensor. Select heating system mode to heat the indoor space to above 40°F.

1(B)(3)(b): a control output coupled to the space conditioning equipment for issuing control signals thereto; and- For instance, the '846 Accused Products connects to multiple heating/cooling devices such as AC and humidifier (control output). These connections help the thermostat to control these devices by sending control signal over these connections.

iComfort Wi-Fi® Thermostat

The communicating iComfort Wi-Fi® thermostat is an electronic 7-day programmable touch-screen thermostat with a color display. It also offers enhanced capabilities which include: humidification measurement and control, dew point adjustment control, dehumidification measurement and control, Humiditrol® Enhanced Dehumidification Accessory (EDA) compatibility, and equipment maintenance reminders. The thermostat's autochangeover mode permits control of heating, cooling, humidification, and dehumidification without user involvement.

<p style="text-align: center;">Figure 13. Registration Screen</p> <p>NOTE - This following information is customer setup instructions and is shown here to allow the installer to help walk the customer through the setup process.</p> <p>After registering through your iComfortWi-Fi® thermostat interface, go to the homeowner's computer and locate the email sent from the server.</p> <p>NOTE - If the customer has already setup an account, click the "Click Here" button to access that account.</p> <p>Click on the Register link; the screen (to the left) will appear. Fill in the User Name and Password fields and check the agree to terms and conditions box. Click Create User button.</p> <p>507341-02</p>	<p style="text-align: center;">Adding Non-Communicating Outdoor Unit and Accessories</p> <p>OUTDOOR UNIT (AIR CONDITIONER OR HEAT PUMP)</p> <p>To add (or remove) an outdoor unit that is not iComfort®-enabled, you must be at the "Add or Remove Non-communicating equipment?" screen.</p> <ol style="list-style-type: none"> 1. Touch the yes button next to Add or Remove Non-communicating equipment? 2. In the "non-communicating device list" screen, use the arrows to highlight Outdoor Unit Type and touch edit. 3. Touch one of the radio buttons to select a 1-or 2-stage air conditioner unit or a 1-or 2-stage heat pump unit; touch save. 4. Use arrows to highlight any red colored text in the device list (e.g. select Outdoor Unit Capacity; text turns white). Touch edit. <p>12</p>
<ol style="list-style-type: none"> 5. Use either the up or down arrows to display the correct size outdoor unit. Touch save to continue. <p>NOTE - If the defaults are correct, you do not have to make any changes, but you must touch save. When all red text is gone, the back button will appear; touch it to return to the "Add or Remove Non-communicating equipment?" screen.</p> <p>ADDING A HUMIDIFIER</p> <p>Before adding a humidifier, be sure that the:</p> <ul style="list-style-type: none"> • Humidifier is wired to the furnace or air handler control as shown on the Optional Accessories wiring diagram (see page 42). • Entire system is wired, powered up, and the thermostat has detected the system's installed communicating devices, and you are at the "Add or Remove Non-communicating equipment?" screen. <p>To add (or remove) a humidifier:</p> <ol style="list-style-type: none"> 1. Touch the yes button on this screen. 2. In the "non-communicating device list" screen, use the arrows to highlight Humidifier (note the current value, Not Installed) and touch edit. 3. Touch one of the radio buttons to select the type of humidifier (or select Not Installed, if removing humidifier); touch save. 4. The previous screen returns, but the current value now shows your selection. Touch the back button. 5. The "Add or Remove..." screen reappears with your addition shown in the system devices list. At this point, you may add more equipment (touch yes) or if finished, touch the next button to advance to the "Adjust a setting..." screen (see page 15). <p>NOTE - Adding humidity regulating non-communicating devices may be a 2-step procedure:</p> <ul style="list-style-type: none"> • First the device must be installed and wired. After the humidifier is installed, the setting under the "System" mode "Humidification Control Mode" defaults to "Basic". 	<ul style="list-style-type: none"> • Second, if you want another mode, i.e. Precision, Basic Dew Point, or Precision Dew Point, the device requires further configuration (see page 15). <p>ADDING HUMIDITROL® OR AN AUXILIARY DEHUMIDIFIER</p> <p>Before adding a dehumidifier, be sure that:</p> <ul style="list-style-type: none"> • the dehumidifier is wired to the furnace or air handler control as shown on the Optional Accessories wiring diagram (see page 42). • the entire system is wired, powered up, and the thermostat has detected the system's installed communicating devices, and you are at the "Add or Remove Non-communicating equipment?" screen. <p>To add (or remove) a dehumidifier, you must be at the "Add or Remove Non-communicating equipment?" screen.</p> <ol style="list-style-type: none"> 1. Touch the yes button on this screen. 2. In the "non-communicating device list" screen, use the arrows to highlight Dehumidifier and touch edit. Note the current value (e.g. Not Installed). 3. Touch one of the radio buttons to select the type of dehumidifier (or select Not Installed, if removing dehumidifier); touch save. 4. When you scroll to the Dehumidifier device, (Note the current value, e.g. Humiditrol.) Click back to return to the "Add or Remove..." screen. 5. The "Add or Remove..." screen reappears with your addition shown in the system devices list. At this point, you may add more equipment (touch yes) or if finished, touch the next button to advance to the "Adjust a setting..." screen. <p>NOTE - Adding humidity regulating non-communicating devices may be a 2-step procedure:</p> <ul style="list-style-type: none"> • First the device must be installed and wired. After the dehumidifier is installed, the setting under the "System" mode "Dehumidification Control Mode" defaults to "Basic". • Second, set Humiditrol® comfort adjust overcooling and the min/max dehumidification setpoints if desired (see page 16).

1(B)(3)(c): an electrical device interface adapted to establish communications between said processor and a plurality of addressable electrical devices for selective actuation and deactuation thereof; said addressable electrical devices being situated within and proximate said conditioned space; and- For instance, the '846 Accused Products connects to multiple heating/cooling devices such as AC and humidifier/dehumidifier.

Figure 13. Registration Screen

NOTE - This following information is customer setup instructions and is shown here to allow the installer to help walk the customer through the setup process.

After registering through your iComfortWi-Fi® thermostat interface, go to the homeowner's computer and locate the email sent from the server.

NOTE - If the customer has already setup an account, click the "Click Here" button to access that account.

Click on the Register link; the screen (to the left) will appear. Fill in the User Name and Password fields and check the agree to terms and conditions box. Click **Create User** button.

507341-02 12

5. Use either the up or down arrows to display the correct size outdoor unit. Touch **save** to continue.

NOTE - If the defaults are correct, you do not have to make any changes, but you must touch save. When all red text is gone, the back button will appear; touch it to return to the "Add or Remove Non-communicating equipment?" screen.

ADDING A HUMIDIFIER

Before adding a humidifier, be sure that the:

- Humidifier is wired to the furnace or air handler control as shown on the Optional Accessories wiring diagram (see page 42).
- Entire system is wired, powered up, and the thermostat has detected the system's installed communicating devices, and you are at the "Add or Remove Non-communicating equipment?" screen.

To add (or remove) a humidifier:

1. Touch the **yes** button on this screen.
2. In the "non-communicating device list" screen, use the arrows to highlight **Humidifier** (note the current value, **Not Installed**) and touch **edit**.
3. Touch one of the radio buttons to select the type of humidifier (or select **Not Installed**, if removing humidifier); touch **save**.
4. The previous screen returns, but the current value now shows your selection. Touch the **back** button.
5. The "Add or Remove..." screen reappears with your addition shown in the system devices list. At this point, you may add more equipment (touch **yes**) or if finished, touch the **next** button to advance to the "Adjust a setting..." screen (see page 15).

NOTE - Adding humidity regulating non-communicating devices may be a 2-step procedure:

- **First** the device must be installed and wired. After the humidifier is installed, the setting under the "System" mode "Humidification Control Mode" defaults to "Basic".

Adding Non-Communicating Outdoor Unit and Accessories

OUTDOOR UNIT (AIR CONDITIONER OR HEAT PUMP)

To add (or remove) an outdoor unit that is not iComfort®-enabled, you must be at the "Add or Remove Non-communicating equipment?" screen.

1. Touch the **yes** button next to **Add or Remove Non-communicating equipment?**
2. In the "non-communicating device list" screen, use the arrows to highlight **Outdoor Unit Type** and touch **edit**.
3. Touch one of the radio buttons to select a 1-or 2-stage air conditioner unit or a 1-or 2-stage heat pump unit; touch **save**.
4. Use arrows to highlight any red colored text in the device list (e.g. select **Outdoor Unit Capacity**; text turns white). Touch **edit**.

• **Second**, if you want another mode, i.e. Precision, Basic Dew Point, or Precision Dew Point, the device requires further configuration (see page 15).

ADDING HUMIDITROL® OR AN AUXILIARY DEHUMIDIFIER

Before adding a dehumidifier, be sure that:

- the dehumidifier is wired to the furnace or air handler control as shown on the Optional Accessories wiring diagram (see page 42).
- the entire system is wired, powered up, and the thermostat has detected the system's installed communicating devices, and you are at the "Add or Remove Non-communicating equipment?" screen.

To add (or remove) a dehumidifier, you must be at the "Add or Remove Non-communicating equipment?" screen.

1. Touch the **yes** button on this screen.
2. In the "non-communicating device list" screen, use the arrows to highlight **Dehumidifier** and touch **edit**. Note the current value (e.g. Not Installed).
3. Touch one of the radio buttons to select the type of dehumidifier (or select **Not Installed**, if removing dehumidifier); touch **save**.
4. When you scroll to the Dehumidifier device, (Note the current value, e.g. Humiditrol.) Click **back** to return to the "Add or Remove..." screen.
5. The "Add or Remove..." screen reappears with your addition shown in the system devices list. At this point, you may add more equipment (touch **yes**) or if finished, touch the **next** button to advance to the "Adjust a setting..." screen.

NOTE - Adding humidity regulating non-communicating devices may be a 2-step procedure:

- **First** the device must be installed and wired. After the dehumidifier is installed, the setting under the "System" mode "Dehumidification Control Mode" defaults to "Basic".
- **Second**, set Humiditrol® comfort adjust overcooling and the min/max dehumidification setpoints if desired (see page 16).

Thermostat Wire Termination in Communicating System

RSBus
Minimum wire size is 18 gauge

Note: iComfort Wi-Fi® thermostat does not require shielded cable wiring.

BEST PRACTICES! Keep all communication wiring as far away from house electric wiring and large electrical appliances as possible (15' [5m] recommended).

Maximum total length of all connections on the RSBus is limited to 1500 ft. (450 m). Max. length between components is 300 ft. (90 m).

Communicating systems using the iComfort Wi-Fi® thermostat require four thermostat wires between the thermostat and the furnace/air handler control and four wires between the outdoor unit and the furnace/air handler control. When a thermostat cable with more than four wires is used, the extra wires must be properly connected to avoid electrical noise. The wires must not be left disconnected.

Use wire nuts to bundle the unused wires at each end of the cable. A single wire should then be connected to the indoor unit end of the wire bundle and attached to the "C" terminals as shown in the diagram above. This is not an issue in non-communicating systems.

45 iComfort Wi-Fi® 7-Day Programmable Communicating Thermostat

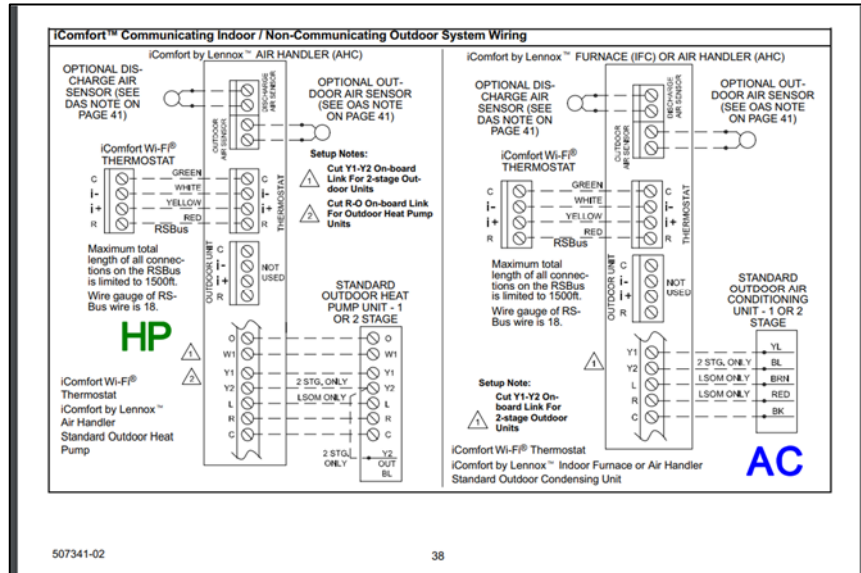

I(C): a program stored in said memory for causing said central processing unit to selectively:- For instance, the '846 Accused Products includes built-in programs, which user can configure.

WARNING

This is a 24VAC Class 2 thermostat. Do not install on voltages higher than 30VAC.

Do not switch system to cool if the outdoor temperature is below 45°F (7°C). This can damage the cooling system.

iComfort Wi-Fi® Thermostat - Technical Description and Features

The 24VAC iComfort Wi-Fi® thermostat is an electronic communicating, color display touchscreen and 7-day programmable thermostat. It stores system parameters and settings in non-volatile memory (i.e., it retains data when electrical power fails or is turned off).

The iComfort Wi-Fi® thermostat can connect to online services via the Internet through the homeowner's Wi-Fi access point. After online registration is completed, the system may then be accessed by the homeowner from anywhere using a remote Internet connection via computer or personal communicating device.

Refer to page 37 for information on making connections to the thermostat.

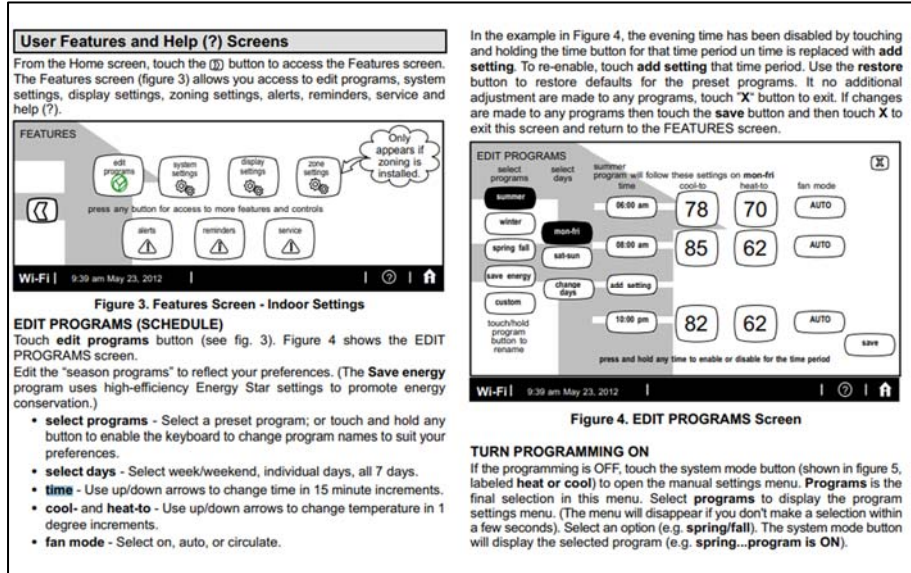

I(C)(1): place said thermostat system into a “vacation” mode; and:- For instance, the '846 Accused Products includes a vacation mode.

I(C)(2): if said thermostat system is in said “vacation” mode, periodically actuate and deactuate predetermined ones of said addressable electrical devices in a predetermined pattern:- For instance, in the '846 Accused Products, a user can set the vacation mode by providing a date and a target heat and cool temp. At the configured time, it automatically changes the mode of thermostat and starts sending commands to electrical devices such as heating/cooling equipment as per the vacation profile configuration to maintain the temperature of the room without user intervention.

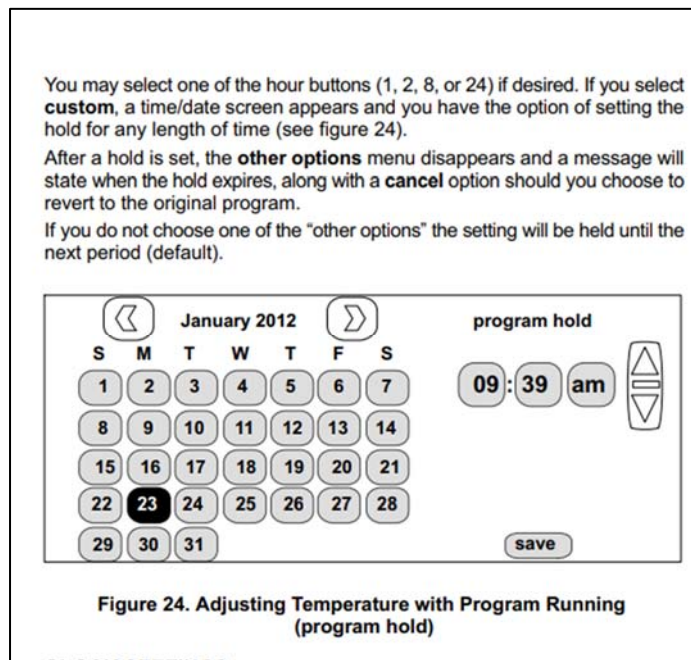
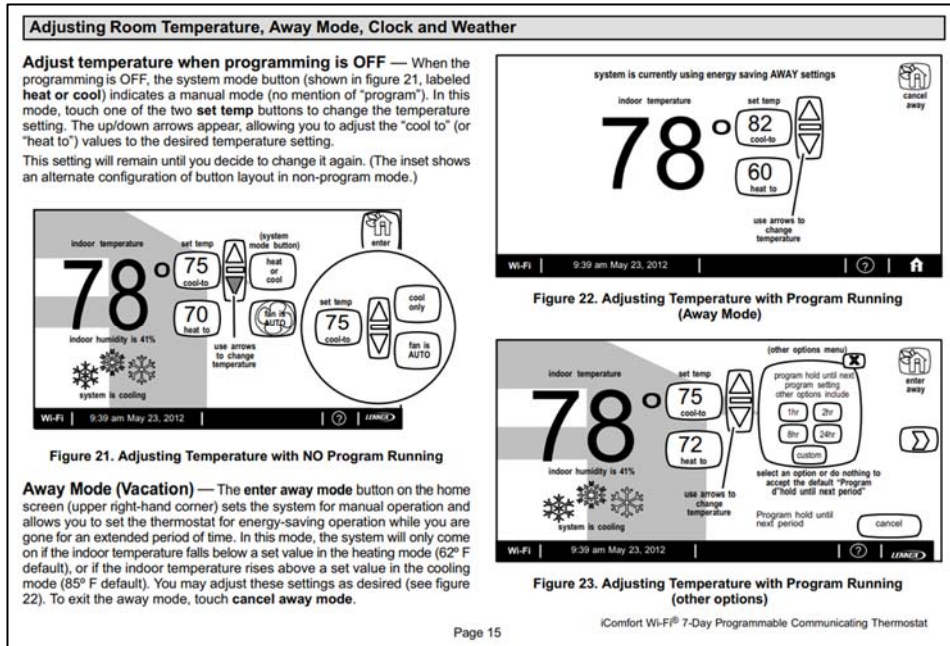

63. At least as early as of the date of the filing of the Complaint, Defendant has had actual knowledge of the '846 Patent.

64. Additionally, Defendant contributorily infringes at least one or more claims of the '846 Patent by providing the '846 Accused Products and/or software components thereof, that embody a material part of the claimed inventions of the '846 Patent, that are known by

Defendant to be specially made or adapted for use in an infringing manner, and are not staple articles with substantial non-infringing uses. The '846 Accused Products are specially designed to infringe at least one or more claims of the '846 Patent, and their accused components have no substantial non-infringing uses. In particular, on information and belief, the software modules and code that implement and perform the infringing functionalities identified above are specially made and adapted to carry out said functionality and do not have any substantial non-infringing uses.

65. At least as early as the filing and/or service of this Complaint, Defendant's infringement of the '846 Patent was and continues to be willful and deliberate, entitling Rosen to enhanced damages.

66. Additional allegations regarding Defendant's knowledge of the '846 Patent and willful infringement will likely have evidentiary support after a reasonable opportunity for discovery.

67. Defendant's infringement of the '846 Patent is exceptional and entitles Rosen to attorneys' fees and costs incurred in prosecuting this action under 35 U.S.C. § 285.

68. Rosen is in compliance with any applicable marking and/or notice provisions of 35 U.S.C. § 287 with respect to the '846 Patent.

69. Rosen is entitled to recover from Defendant all damages that Rosen has sustained as a result of Defendant's infringement of the '846 Patent, including, without limitation, a reasonable royalty.

COUNT II: INFRINGEMENT OF U.S. PATENT NO. 6,619,555

70. Rosen incorporates by reference and re-alleges paragraphs 1-69 of this Complaint as if fully set forth herein.

71. Defendant has infringed and is infringing, either literally or under the doctrine of equivalents, the '555 Patent in violation of 35 U.S.C. § 271 *et seq.*, directly and/or indirectly, by making, using, offering for sale, or selling in the United States, and/or importing into the United States without authority or license, the Lennox iComfort Wi-Fi Thermostat, and other substantially similar products (the "'555 Accused Products").

72. As just one non-limiting example, set forth below (with claim language in bold and italics) is exemplary evidence of infringement of Claim 18 of the '555 Patent in connection with the '555 Accused Products. This description is based on publicly available information. Rosen reserves the right to modify this description, including, for example, on the basis of information about the '555 Accused Products that it obtains during discovery.

18) thermostat system for controlling space conditioning equipment comprising: - For instance, the '555 Accused Product is a thermostat system.

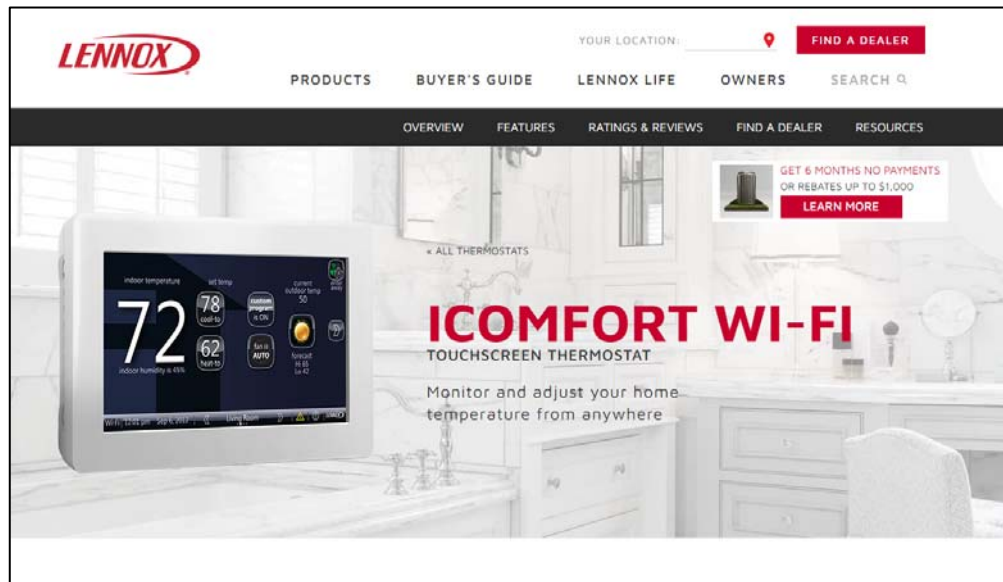

- This thermostat supports:
- Wireless bands 802.11b, 802.11g and 802.11n
 - Three languages (English, French, Spanish)
 - Air conditioning or heat pump units with up to four stages of heat / two stages of compressor operation (2 stages of heat pump heating, 2 stages of auxiliary back-up heating and 2 stages of emergency heating)
 - Variable-capacity / multiple-stage heat / cool and universal compatibility (gas/electric/heat pump/air conditioner).
 - Dual-fuel capable (iComfort®-enabled HP only) with two balance points.
 - Indoor air quality with time-based notification of consumables including media filters, UVC bulbs, humidifier pads and PureAir™ system catalyst service / replacement,
 - iHarmony® Zoning System (2 - 4 zones)
 - Lennox iComfort® Equipment Interface Module (Catalog number 10T50) (provides iComfort Wi-Fi® to non-communicating indoor unit,
 - Humidification measurement and control.
 - Dew point adjustment control
 - Humiditrol® Enhanced Dehumidification Accessory (EDA)
 - Multiple-stage HVAC systems
 - Equipment maintenance reminders
 - Autochangeover mode – Permits control of heating, cooling, humidification, and dehumidification without user involvement
 - All Lennox branded communicating outdoor units contain a built-in outdoor temperature sensor.

18(A) a temperature sensor for providing an electrical signal indicative of the temperature of a conditioned space in which the temperature sensor is situated;— For instance, the '555 Accused Product includes temperature sensors for detecting temperature in the installed location. The sensor further sends the corresponding temperature value to the thermostat.

29	Critical	(Thermostat) The thermostat is reading an indoor temperature that is higher than 99°F. The thermostat will not allow any heating operation to begin until it senses a temperature lower than 99°F.	Indoor temperature rose above 99°F during a heating or cooling demand. Heating operation is not allowed. Check to ensure that Heating Equipment is not stuck ON (reversing valve, etc.). Check the accuracy of the thermostat temperature sensor. Select cooling system mode to cool the indoor space.
30	Moderate	(Thermostat) The thermostat is reading an indoor temperature that is lower than 40°F. The thermostat will not allow any cooling operation to begin until it senses a temperature higher than 40°F.	Indoor Temp fell below 40°F. Cooling operation is not allowed. Check to ensure that cooling equipment is not stuck ON. Check accuracy of the thermostat temperature sensor . Select heating system mode to heat the indoor space to above 40°F.

18(B): a liquid crystal display for selectively displaying an alphanumeric message; - For instance, the '555 Accused Products include an LCD touchscreen that displays various options, including temperature, to a user.



Alerts and Reminders: Not only will your iComfort Wi-Fi monitor itself with advanced diagnostics, but it can also send you and your dealer alerts and emails if the system needs service or maintenance.

Smart Energy Use: Seasonal schedules save energy all year long, while One-Touch Away Mode helps your system use less when no one is home.

App-Enabled: Free to download for Apple and Android devices, the iComfort App is like a touchscreen window into your home comfort. Whether you're on the road or on the couch, simply start the app to check and change your temperature with only a finger.

Convenience

Touchscreen Operation: The bright, clear screen is easy to read in any light, and easy to operate with just one finger.

One-Touch Away Mode: One touch or remote click will put your system into One-Touch Away Mode, reducing system use and energy consumption when no one is home.

Weather Data: The iComfort Wi-Fi can display live weather alerts and a five-day forecast, so you're always prepared for what's happening outside.

Screen Saver: Customize your thermostat by uploading a family picture.

Remote Access: Once connected to the Cloud through your wireless network, your iComfort Wi-Fi can be adjusted from anywhere in the world via your smartphone, tablet, laptop or other web-enabled device.

Innovation



App-Enabled: Free to download for Apple and Android devices, the iComfort App is like a touchscreen window into your home comfort. Whether you're on the road or on the couch, simply start the app to check and change your temperature with only a finger.

Comfort

Perfect Air: The iComfort Wi-Fi works with your Lennox® system to carefully control both temperature and humidity, filling your home with perfectly comfortable air.

Peace of Mind: Like all Lennox equipment, the iComfort Wi-Fi is built to deliver more, and built to last. So you'll enjoy reliable comfort season after season.

Precise Control: For the ultimate in home comfort, pair the iComfort Wi-Fi thermostat with iHarmony Zoning to customize the temperature in any area of your home. Zoning not only helps eliminate hot and cold spots, but also helps you save money on utility bills by ensuring that you are not heating or cooling seldom-used areas of your home, like guest rooms or media rooms.

User Features and Help (?) Screens

From the Home screen, touch the (?) button to access the Features screen. The Features screen (figure 3) allows you access to edit programs, system settings, zoning settings, alerts, reminders, service and help (?).

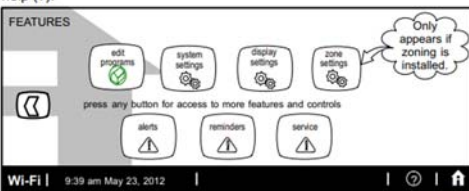

Figure 3. Features Screen - Indoor Settings

EDIT PROGRAMS (SCHEDULE)

Touch **edit programs** button (see fig. 3). Figure 4 shows the EDIT PROGRAMS screen.

Edit the "season programs" to reflect your preferences. (The **Save energy** program uses high-efficiency Energy Star settings to promote energy conservation.)

- select programs** - Select a preset program; or touch and hold any button to enable the keyboard to change program names to suit your preferences.
- select days** - Select week/weekend, individual days, all 7 days.
- time** - Use up/down arrows to change time in 15 minute increments.
- cool-** and **heat-to** - Use up/down arrows to change temperature in 1 degree increments.
- fan mode** - Select on, auto, or circulate.

In the example in Figure 4, the evening time has been disabled by touching and holding the time button for that time period un time is replaced with **add setting**. To re-enable, touch **add setting** that time period. Use the **restore** button to restore defaults for the preset programs. If no additional adjustment are made to any programs, touch **X** button to exit. If changes are made to any programs then touch the **save** button and then touch **X** to exit this screen and return to the FEATURES screen.

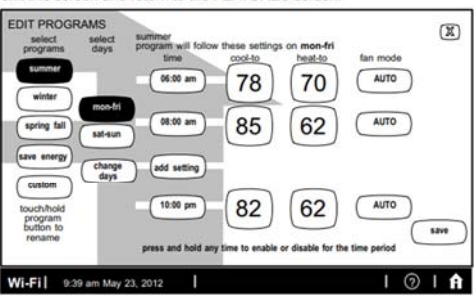

Figure 4. EDIT PROGRAMS Screen

TURN PROGRAMMING ON

If the programming is OFF, touch the system mode button (shown in figure 5, labeled **heat or cool**) to open the manual settings menu. **Programs** is the final selection in this menu. Select **programs** to display the program settings menu. (The menu will disappear if you don't make a selection within a few seconds). Select an option (e.g. **spring/fall**). The system mode button will display the selected program (e.g. **spring...program is ON**).

Touchscreen

Features a large, easy-to-use display with adjustable brightness



I(C): processor, said processor including;— For instance, the '555 Accused Products includes a processor; further including.

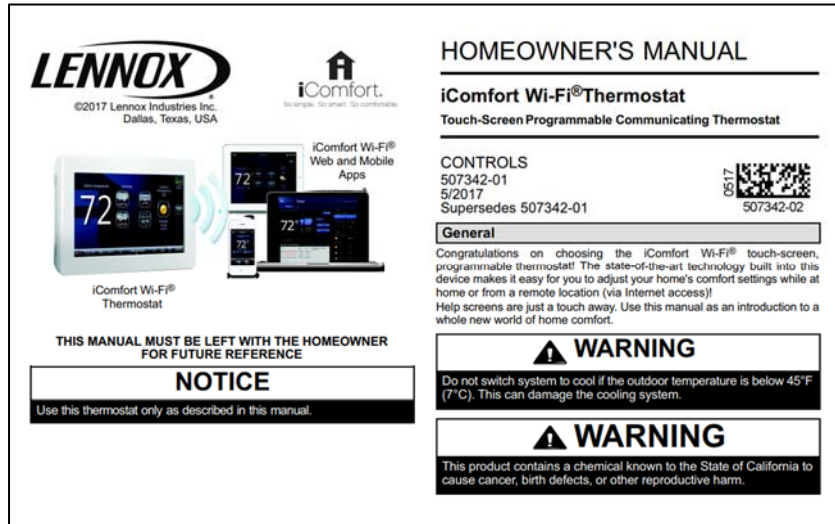

I(C)(1): a central processing unit;—For instance, the '555 Accused Products includes a central processing unit.



I(C)(2): a real time clock;—For instance, the '555 Accused Products includes a processor having a real time clock.

Adjusting System Setting

SET TIME AND DATE

Use the arrows to select **Time and Date**; touch **edit** to proceed to the "Set current time and date" screen.

When "Time and Date" screen appears, enter the correct date as follows:

- Use the left and right arrows to change the month and year.
- Touch a day of the month to select it.
- Touch on the hour or minute; up down arrows appear to allow change.
- Touch the **am/pm** field to toggle it between am and pm.
- When the correct date and time is set, touch **save** to save settings and return to previous settings screen.

Touch **next** to continue to next screen.

I(C)(3): a memory coupled to said central processing unit for storing program and data information; and;— For instance, the '555 Accused Products includes a memory coupled to the CPU.

 **WARNING**

This is a 24VAC Class 2 thermostat. Do not install on voltages higher than 30VAC.

Do not switch system to cool if the outdoor temperature is below 45°F (7°C). This can damage the cooling system.

iComfort Wi-Fi® Thermostat - Technical Description and Features

The 24VAC iComfort Wi-Fi® thermostat is an electronic communicating, color display touchscreen and 7-day programmable thermostat. It stores system parameters and settings in non-volatile memory (i.e., it retains data when electrical power fails or is turned off).

The iComfort Wi-Fi® thermostat can connect to online services via the Internet through the homeowner's Wi-Fi access point. After online registration is completed, the system may then be accessed by the homeowner from anywhere using a remote Internet connection via computer or personal communicating device.

Refer to page 37 for information on making connections to the thermostat.

I(C)(4): an input/output unit including - For instance, the '555 Accused Products includes a processor in the thermostat having I/O modules. The I/O modules are coupled with the processor.

This thermostat supports:

- Wireless bands 802.11b, 802.11g and 802.11n
- Three languages (English, French, Spanish)
- Air conditioning or heat pump units with up to four stages of heat / two stages of compressor operation (2 stages of heat pump heating, 2 stages of auxiliary back-up heating and 2 stages of emergency heating)
- Variable-capacity / multiple-stage heat / cool and universal compatibility (gas/electric/heat pump/air conditioner).
- Dual-fuel capable (iComfort®-enabled HP only) with two balance points.
- Indoor air quality with time-based notification of consumables including media filters, UVC bulbs, humidifier pads and PureAir™ system catalyst service / replacement,
- iHarmony® Zoning System (2 - 4 zones)
- Lennox iComfort® Equipment Interface Module (Catalog number 10T50) (provides iComfort Wi-Fi® to non-communicating indoor unit,
- Humidification measurement and control.
- Dew point adjustment control
- Humiditrol® Enhanced Dehumidification Accessory (EDA)
- Multiple-stage HVAC systems
- Equipment maintenance reminders
- Autochangeover mode -- Permits control of heating, cooling, humidification, and dehumidification without user involvement
- All Lennox branded communicating outdoor units contain a built-in outdoor temperature sensor.

Figure 13. Registration Screen

NOTE - This following information is customer setup instructions and is shown here to allow the installer to help walk the customer through the setup process.

After registering through your iComfort Wi-Fi® thermostat interface, go to the homeowner's computer and locate the email sent from the server.

NOTE - if the customer has already setup an account, click the "Click Here" button to access that account.

Click on the Register link; the screen (to the left) will appear. Fill in the User Name and Password fields and check the agree to terms and conditions box. Click **Create User** button.

507341-02 12

Adding Non-Communicating Outdoor Unit and Accessories

OUTDOOR UNIT (AIR CONDITIONER OR HEAT PUMP)
To add (or remove) an outdoor unit that is not iComfort®-enabled, you must be at the "Add or Remove Non-communicating equipment?" screen.

1. Touch the **yes** button next to **Add or Remove Non-communicating equipment?**
2. In the "non-communicating device list" screen, use the arrows to highlight **Outdoor Unit Type** and touch **edit**.
3. Touch one of the radio buttons to select a 1-or 2-stage air conditioner unit or a 1-or 2-stage heat pump unit; touch **save**.
4. Use arrows to highlight any red colored text in the device list (e.g. select **Outdoor Unit Capacity**; text turns white). Touch **edit**.

5. Use either the up or down arrows to display the correct size outdoor unit. Touch **save** to continue.

NOTE - If the defaults are correct, you do not have to make any changes, but you must touch **save. When all red text is gone, the **back** button will appear; touch it to return to the "Add or Remove Non-communicating equipment?" screen.**

ADDING A HUMIDIFIER

Before adding a humidifier, be sure that the:

- Humidifier is wired to the furnace or air handler control as shown on the Optional Accessories wiring diagram (see page 42).
- Entire system is wired, powered up, and the thermostat has detected the system's installed communicating devices, and you are at the "Add or Remove Non-communicating equipment?" screen.

To add (or remove) a humidifier:

1. Touch the **yes** button on this screen.
2. In the "non-communicating device list" screen, use the arrows to highlight **Humidifier** (note the current value, **Not Installed**) and touch **edit**.
3. Touch one of the radio buttons to select the type of humidifier (or select **Not Installed**, if removing humidifier); touch **save**.
4. The previous screen returns, but the current value now shows your selection. Touch the **back** button.
5. The "Add or Remove..." screen reappears with your addition shown in the system devices list. At this point, you may add more equipment (touch **yes**) or if finished, touch the **next** button to advance to the "Adjust a setting..." screen (see page 15).

NOTE - Adding humidity regulating non-communicating devices may be a 2-step procedure:

- **First** the device must be installed and wired. After the humidifier is installed, the setting under the "System" mode "Humidification Control Mode" defaults to "Basic".
- **Second**, if you want another mode, i.e. Precision, Basic Dew Point, or Precision Dew Point, the device requires further configuration (see page 15).

ADDING HUMIDITROL® OR AN AUXILIARY DEHUMIDIFIER

Before adding a dehumidifier, be sure that:

- the dehumidifier is wired to the furnace or air handler control as shown on the Optional Accessories wiring diagram (see page 42).
- the entire system is wired, powered up, and the thermostat has detected the system's installed communicating devices, and you are at the "Add or Remove Non-communicating equipment?" screen.

To add (or remove) a dehumidifier, you must be at the "Add or Remove Non-communicating equipment?" screen.

1. Touch the **yes** button on this screen.
2. In the "non-communicating device list" screen, use the arrows to highlight **Dehumidifier** and touch **edit**. Note the current value (e.g. Not Installed).
3. Touch one of the radio buttons to select the type of dehumidifier (or select **Not Installed**, if removing dehumidifier); touch **save**.
4. When you scroll to the Dehumidifier device, (Note the current value, e.g. Humiditrol.) Click **back** to return to the "Add or Remove..." screen.
5. The "Add or Remove..." screen reappears with your addition shown in the system devices list. At this point, you may add more equipment (touch **yes**) or if finished, touch the **next** button to advance to the "Adjust a setting..." screen.

NOTE - Adding humidity regulating non-communicating devices may be a 2-step procedure:

- **First** the device must be installed and wired. After the dehumidifier is installed, the setting under the "System" mode "Dehumidification Control Mode" defaults to "Basic".
- **Second**, set Humiditrol® comfort adjust overcooling and the min/max dehumidification setpoints if desired (see page 16).

While iComfort Wi-Fi is designed for use with premium Lennox® equipment, the iComfort Wi-Fi Flex can work with almost any system. So no matter what type of home heating and cooling equipment you have, you can enjoy the innovation of Lennox, and a more comfortable, energy-efficient home.



	iComfort Wi-Fi®	iComfort Wi-Fi® Flex
Compatible with Lennox®-brand communicating heating and cooling equipment	•	
Compatible with Lennox-brand non-communicating equipment and most other brands of heating and cooling equipment		•
Touchscreen Operation	•	•
Remote Access	•	•
7-Day Programmable	•	•
One-Touch Away	•	•
5-Day Weather Forecast	•	•
Customizable Reminders	•	•
Automatic Updates	•	•
Dual-Fuel Compatible	•	•
Humidity Control	•	•
Diagnostics and Alerts	Highly Advanced	Limited Reporting
Compatible with zoned systems	Designed for integration with iHarmony® Zoning System	
Exchanges information with heating and cooling equipment	Uses Lennox Precise Comfort® Technology to optimize system performance	
Warranty	5-Year Limited	5-Year Limited

I(C)(4)(a): a sensor input coupled to said temperature sensor for receiving said electrical signal therefrom- For instance, the '555 Accused Products includes a built-in temperature sensor, which senses the temperature around and sends a signal indicative of the temperature to the processor of thermostat. Also, it receives temperatures from its built-in sensor. This received temperature is displayed on the thermostat's LCD display

29	Critical	(Thermostat) The thermostat is reading an indoor temperature that is higher than 99°F. The thermostat will not allow any heating operation to begin until it senses a temperature lower than 99°F.	Indoor temperature rose above 99°F during a heating or cooling demand. Heating operation is not allowed. Check to ensure that Heating Equipment is not stuck ON (reversing valve, etc.). Check the accuracy of the thermostat temperature sensor. Select cooling system mode to cool the indoor space.
30	Moderate	(Thermostat) The thermostat is reading an indoor temperature that is lower than 40°F. The thermostat will not allow any cooling operation to begin until it senses a temperature higher than 40°F.	Indoor Temp fell below 40°F. Cooling operation is not allowed. Check to ensure that cooling equipment is not stuck ON. Check accuracy of the thermostat temperature sensor. Select heating system mode to heat the indoor space to above 40°F.

I(C)(4)(b): a control output coupled to the space conditioning equipment for issuing control signals thereto; and- For instance, the '555 Accused Products connects to the heating or cooling systems based on heating or cooling signals generating from the output present in the thermostat.

iComfort Wi-Fi® Thermostat

The communicating iComfort Wi-Fi® thermostat is an electronic 7-day programmable touch-screen thermostat with a color display. It also offers enhanced capabilities which include: humidification measurement and control, dew point adjustment control, dehumidification measurement and control, Humiditrol® Enhanced Dehumidification Accessory (EDA) compatibility, and equipment maintenance reminders. The thermostat's autochangeover mode permits control of heating, cooling, humidification, and dehumidification without user involvement.

Figure 13. Registration Screen

NOTE - This following information is customer setup instructions and is shown here to allow the installer to help walk the customer through the setup process.

After registering through your iComfortWi-Fi® thermostat interface, go to the homeowner's computer and locate the email sent from the server.

NOTE - if the customer has already setup an account, click the "Click Here" button to access that account.

Click on the Register link; the screen (to the left) will appear. Fill in the User Name and Password fields and check the agree to terms and conditions box. Click **Create User** button.

507341-02 12

Adding Non-Communicating Outdoor Unit and Accessories

OUTDOOR UNIT (AIR CONDITIONER OR HEAT PUMP)

To add (or remove) an outdoor unit that is not iComfort®-enabled, you must be at the "Add or Remove Non-communicating equipment?" screen.

1. Touch the **yes** button next to **Add or Remove Non-communicating equipment?**
2. In the "non-communicating device list" screen, use the arrows to highlight **Outdoor Unit Type** and touch **edit**.
3. Touch one of the radio buttons to select a 1-or 2-stage air conditioner unit or a 1-or 2-stage heat pump unit; touch **save**.
4. Use arrows to highlight any red colored text in the device list (e.g. select **Outdoor Unit Capacity**; text turns white). Touch **edit**.

5. Use either the up or down arrows to display the correct size outdoor unit. Touch **save** to continue.

NOTE - If the defaults are correct, you do not have to make any changes, but you must touch save. When all red text is gone, the back button will appear; touch it to return to the "Add or Remove Non-communicating equipment?" screen.

ADDING A HUMIDIFIER

Before adding a humidifier, be sure that the:

- Humidifier is wired to the furnace or air handler control as shown on the Optional Accessories wiring diagram (see page 42).
- Entire system is wired, powered up, and the thermostat has detected the system's installed communicating devices, and you are at the "Add or Remove Non-communicating equipment?" screen.

To add (or remove) a humidifier:

1. Touch the **yes** button on this screen.
2. In the "non-communicating device list" screen, use the arrows to highlight **Humidifier** (note the current value, **Not Installed**) and touch **edit**.
3. Touch one of the radio buttons to select the type of humidifier (or select **Not Installed**, if removing humidifier); touch **save**.
4. The previous screen returns, but the current value now shows your selection. Touch the **back** button.
5. The "Add or Remove..." screen reappears with your addition shown in the system devices list. At this point, you may add more equipment (touch **yes**) or if finished, touch the **next** button to advance to the "Adjust a setting..." screen.

NOTE - Adding humidity regulating non-communicating devices may be a 2-step procedure:

- **First** the device must be installed and wired. After the humidifier is installed, the setting under the "System" mode "Humidification Control Mode" defaults to "Basic".
- **Second**, if you want another mode, i.e. Precision, Basic Dew Point, or Precision Dew Point, the device requires further configuration (see page 15).

ADDING HUMIDITROL® OR AN AUXILIARY DEHUMIDIFIER

Before adding a dehumidifier, be sure that:

- the dehumidifier is wired to the furnace or air handler control as shown on the Optional Accessories wiring diagram (see page 42),
- the entire system is wired, powered up, and the thermostat has detected the system's installed communicating devices, and you are at the "Add or Remove Non-communicating equipment?" screen.

To add (or remove) a dehumidifier, you must be at the "Add or Remove Non-communicating equipment?" screen.

1. Touch the **yes** button on this screen.
2. In the "non-communicating device list" screen, use the arrows to highlight **Dehumidifier** and touch **edit**. Note the current value (e.g. Not Installed).
3. Touch one of the radio buttons to select the type of dehumidifier (or select **Not Installed**, if removing dehumidifier); touch **save**.
4. When you scroll to the Dehumidifier device, (Note the current value, e.g. Humiditrol.) Click **back** to return to the "Add or Remove..." screen.
5. The "Add or Remove..." screen reappears with your addition shown in the system devices list. At this point, you may add more equipment (touch **yes**) or if finished, touch the **next** button to advance to the "Adjust a setting..." screen.

NOTE - Adding humidity regulating non-communicating devices may be a 2-step procedure:

- **First** the device must be installed and wired. After the dehumidifier is installed, the setting under the "System" mode "Dehumidification Control Mode" defaults to "Basic".
- **Second**, set Humiditrol® comfort adjust overcooling and the min/max dehumidification setpoints if desired (see page 16).

I(C)(4)(c): a communications interface adapted to establish bi-directional communications between said processor and a first remote correspondent which is a source of current information; and- For instance, the '555 Accused Products includes an interface to connect to the internet using Wi-Fi for receiving weather information from the internet.

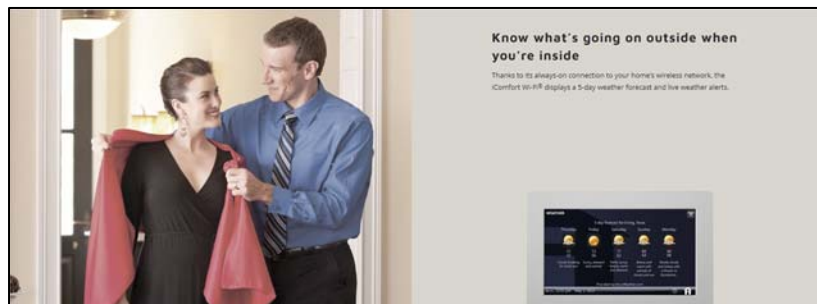

Registering the Thermostat

REGISTRATION FOR ONLINE ACCESS

- From the WI-FI SETTINGS screen, press either the **thermostat not registered** icon or the **connection status** icon and select the **server** icon.

press to change network settings Wi-Fi enabled press to enable / disable Wi-Fi AP3 connected press to toggle off / auto thermostat not registered press to change thermostat registration

72° router internet server

- Enter homeowner email address and press the register button.

Register with iComfort Wi-Fi thermostat to enable remote access and online weather information

enter your email

System Desc

register

- A pop-up screen will appear asking if the email address below is correct? Verify the email address is correct and press **yes**.

4. Another pop-up screen will appear notifying the user to check their email.

An email has been sent to xxxxxxxx@lennoxind.com with instructions on how to register your thermostat. If you haven't received the email, please check your spam folder and make sure that your email address is correct.

NOTE - If the email address originally entered is incorrect, return to the thermostat registered screen and reenter the correct information and press register.

- After the server sends the email with the network link, registration and account creation must be completed from the homeowners personal computer.

NOTE - Time from pushing the registration button on the thermostat and receiving the consumer portal register link from your email on your computer is normally from 5 to 15 minutes depending on Internet speed and traffic.

NOTE - Registration cannot be completed from any mobile device.
- After registration has been completed, press the connection status icon to verify the connection was successful. If the connection is successful the server icon background will be green.

72° router internet server

- After successful connection to the server is completed, the **firmware update** button will appear. The default setting is set to auto. If any firmware updates are available they will immediately start downloading and update the thermostat. The thermostat will reboot itself after the update is completed. Updates are done in the background and will not impair normal thermostat operations.

This auto update feature can be disabled by pressing the firmware update button to toggle to OFF however this is not recommended.

Page 25 iComfort Wi-Fi® 7-Day Programmable Communicating Thermostat

I(D): means coupling said communications interface and said first remote correspondent; and:- For instance, the '555 Accused Products includes means for connecting to the internet.

- Press and release **Wi-Fi** in the lower left corner of the HOME screen

Indoor temperature 78° let temp 75° heat or cool outdoor temperature 80° enter away

indoor humidity is 41% 72° heat-to cool-to

system is cooling Wi-Fi 9:30 am May 23, 2012 Zone 1 (IMM)

Figure 34. Press Wi-Fi

- Press the **Wi-Fi disable** button to enable Wi-Fi.

Wi-Fi SETTINGS Thermostat is not connected to the Wi-Fi network

Wi-Fi disabled Press to enable / disable Wi-Fi

Figure 35. Enable Wi-Fi

3. The **User Agreement** screens will appear next. Press **next** as many times as necessary; then press **accept** after reading the User Agreement.

ESTABLISHING A WI-FI CONNECTIONS

There are two methods to setup your Wi-Fi connection. Select either **NETWORK SETTINGS** or **connection status**.

Method 1 — Network Settings Method

- Press **NETWORK SETTINGS**; this screen shows a graphical view of buttons representing **OPEN** and **SECURE** Wi-Fi networks and a button for adding a network.

Wi-Fi SETTINGS Thermostat is not connected to the Wi-Fi network

connection status Wi-Fi enabled NETWORK SETTINGS

Press to see connection status press to enable / disable Wi-Fi press to change network settings

Must setup a network connection before registering thermostat

Figure 36. Enable Wi-Fi

- Open** connection which requires no password.
- Secure** connection which requires Wi-Fi password (security key).
- Add a network** is required when Wi-Fi identification (SSID) is being hidden (not broadcasting). You will need to know the Wi-Fi network name (SSID), security encryption type (if enabled), and security password (if security encryption is enabled).

- When selecting a:
 - unsecured** connection a screen will appear with two options, **connect** and **router info**. Press **connect** to continue.
 - secured** connection a screen will appear requesting the Wi-Fi network password (security key). There are two options to select from which are **connect** and **router info**. Using the on-screen keyboard, enter the password (security key) and then press **connect** to continue.

Page 21 iComfort Wi-Fi® 7-Day Programmable Communicating Thermostat

Registering the Thermostat

REGISTRATION FOR ONLINE ACCESS

- From the WI-FI SETTINGS screen, press either the **thermostat not registered** icon or the **connection status** icon and select the **server** icon.

WI-FI SETTINGS

press to change network settings

press to enable / disable Wi-Fi

press to toggle off / auto

press to change thermostat registration

72°

router internet server

- Enter homeowner email address and press the register button.

Register with iComfort Wi-Fi thermostat to enable remote access and online weather information

enter your email

System Desc

register

- A pop-up screen will appear asking if the email address below is correct? Verify the email address is correct and press **yes**.

4. Another pop-up screen will appear notifying the user to check their email.

An email has been sent to xxxxxxxx@lennoxind.com with instructions on how to register your thermostat. If you haven't received the email, please check your spam folder and make sure that your email address is correct.

NOTE - If the email address originally entered is incorrect, return to the thermostat registered screen and reenter the correct information and press register.

- After the server sends the email with the network link, registration and account creation must be completed from the homeowners personal computer.

NOTE - Time from pushing the registration button on the thermostat and receiving the consumer portal register link from your email on your computer is normally from 5 to 15 minutes depending on Internet speed and traffic.

NOTE - Registration cannot be completed from any mobile device.

- After registration has been completed, press the connection status icon to verify the connection was successful. If the connection is successful the server icon background will be green.

router internet server

- After successful connection to the server is completed, the **firmware update** button will appear. The default setting is set to auto. If any firmware updates are available they will immediately start downloading and update the thermostat. The thermostat will reboot itself after the update is completed. Updates are done in the background and will not impair normal thermostat operations.

This auto update feature can be disabled by pressing the firmware update button to toggle to OFF however this is not recommended.

iComfort Wi-Fi® 7-Day Programmable Communicating Thermostat

Page 25

1(E): a program stored in said memory for displaying messages received from said first remote correspondent, which received messages do not pertain to the operation of said thermostat system, on said liquid crystal display.- For instance, the '555 Accused Products includes a weekly forecast program that uses the weather information received from the internet (first remote correspondent). The thermostat also displays weather data on the LCD touchscreen.

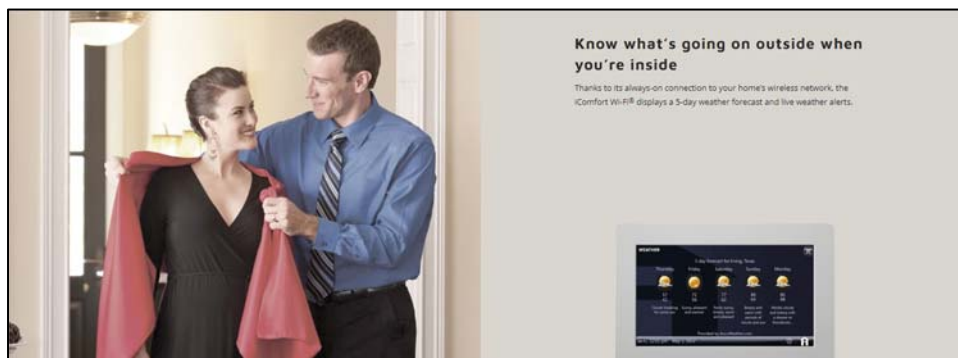

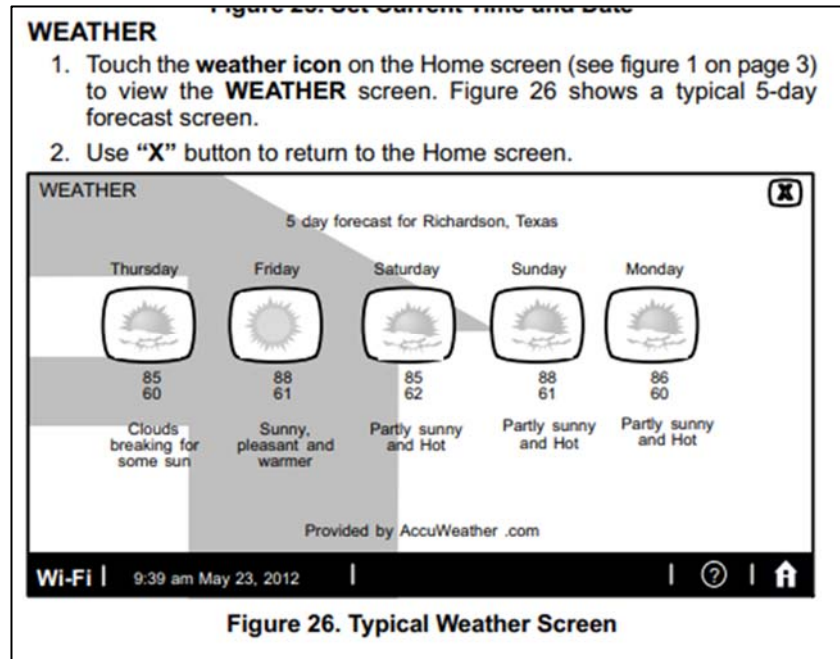

73. At least as early as of the date of the filing of the Complaint, Defendant has had actual knowledge of the '555 Patent.

74. Additionally, Defendant contributorily infringes at least one or more claims of the '555 Patent by providing the '555 Accused Products and/or software components thereof, that embody a material part of the claimed inventions of the '555 Patent, that are known by Defendant to be specially made or adapted for use in an infringing manner, and are not staple articles with substantial non-infringing uses. The '555 Accused Products are specially designed to infringe at least one or more claims of the '555 Patent, and their accused components have no substantial non-infringing uses. In particular, on information and belief, the software modules and code that implement and perform the infringing functionalities identified above are specially made and adapted to carry out said functionality and do not have any substantial non-infringing uses.

75. At least as early as the filing and/or service of this Complaint, Defendant's infringement of the '555 Patent was and continues to be willful and deliberate, entitling Rosen to

enhanced damages.

76. Additional allegations regarding Defendant's knowledge of the '555 Patent and willful infringement will likely have evidentiary support after a reasonable opportunity for discovery.

77. Defendant's infringement of the '555 Patent is exceptional and entitles Rosen to attorneys' fees and costs incurred in prosecuting this action under 35 U.S.C. § 285.

78. Rosen is in compliance with any applicable marking and/or notice provisions of 35 U.S.C. § 287 with respect to the '555 Patent.

79. Rosen is entitled to recover from Defendant all damages that Rosen has sustained as a result of Defendant's infringement of the '555 Patent, including, without limitation, a reasonable royalty.

COUNT III: INFRINGEMENT OF U.S. PATENT NO. 6,789,739

80. Rosen incorporates by reference and re-alleges paragraphs 1-79 of this Complaint as if fully set forth herein

81. Defendant has infringed and is infringing, either literally or under the doctrine of equivalents, the '739 Patent in violation of 35 U.S.C. § 271 *et seq.*, directly and/or indirectly, by making, using, offering for sale, or selling in the United States, and/or importing into the United States without authority or license, among other things, the Lennox iComfort Wi-Fi Thermostat, and other substantially similar products ("the '739 Accused Products").

82. As just one non-limiting example, set forth below (with claim language in bold and italics) is exemplary evidence of infringement of Claim 1 of the '739 Patent in connection with the '739 Accused Products. This description is based on publicly available information. Rosen reserves the right to modify this description, including, for example, on the basis of

information about the '739 Accused Products that it obtains during discovery

1.: A location response system with an environmental controller located at a single physical location adapted to be an integral part of a system of environmental sensing or control for a local and substantially enclosed space comprising: - For instance, the '739 Accused Product is a thermostat system which can provide information related to the indoor and outdoor environments of a home and display the local weather information based on postal /zip code of an area.

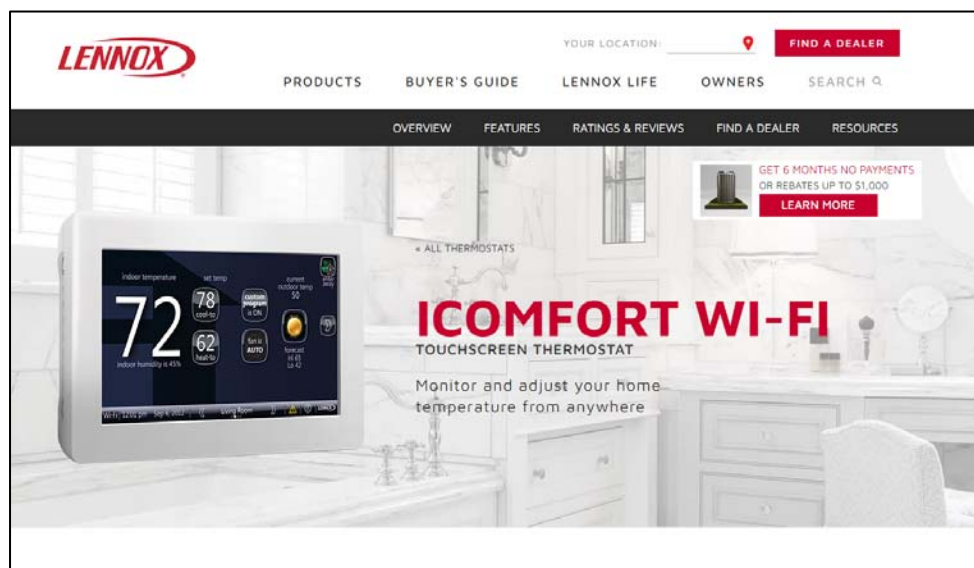

- This thermostat supports:
- Wireless bands 802.11b, 802.11g and 802.11n
 - Three languages (English, French, Spanish)
 - Air conditioning or heat pump units with up to four stages of heat / two stages of compressor operation (2 stages of heat pump heating, 2 stages of auxiliary back-up heating and 2 stages of emergency heating)
 - Variable-capacity / multiple-stage heat / cool and universal compatibility (gas/electric/heat pump/air conditioner).
 - Dual-fuel capable (iComfort®-enabled HP only) with two balance points.
 - Indoor air quality with time-based notification of consumables including media filters, UVC bulbs, humidifier pads and PureAir™ system catalyst service / replacement,
 - iHarmony® Zoning System (2 - 4 zones)
 - Lennox iComfort® Equipment Interface Module (Catalog number 10T50) (provides iComfort Wi-Fi® to non-communicating indoor unit,
 - Humidification measurement and control.
 - Dew point adjustment control
 - Humiditro® Enhanced Dehumidification Accessory (EDA)
 - Multiple-stage HVAC systems
 - Equipment maintenance reminders
 - Autochangeover mode – Permits control of heating, cooling, humidification, and dehumidification without user involvement
 - All Lennox branded communicating outdoor units contain a built-in outdoor temperature sensor.

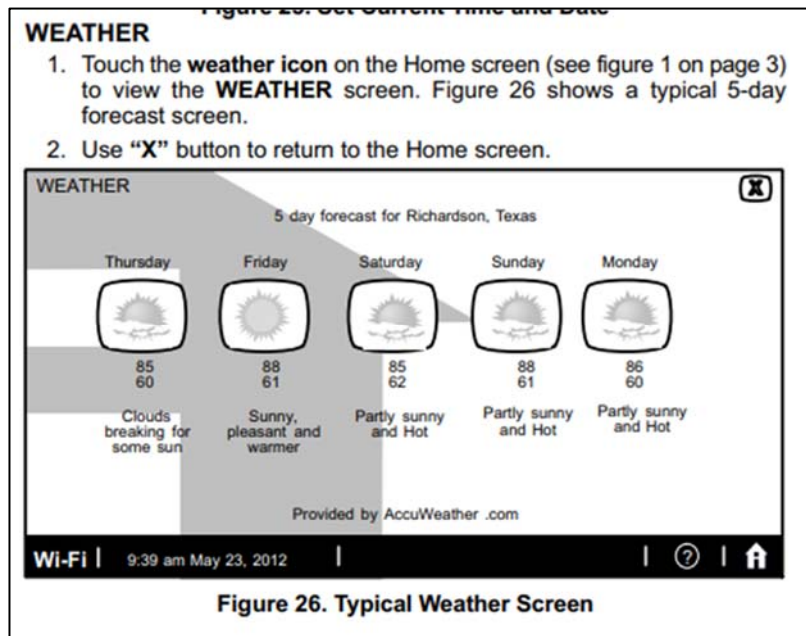

1(A) a physical location of the environmental controller stored as location data in storage means in the controller;— For instance, the '739 Accused Products display the local

weather information based on postal/zip code of an area. The address/zip code is saved by the thermostat to show weather forecast for that area based on that zip code.

<p>Remote Capability</p> <p>Monitor and adjust temperatures and schedules from anywhere in the world using the iComfort App and your smartphone, tablet or other web-enabled device</p>	<p>✓</p>
<p>Weather-On-Demand</p> <p>Air quality conditions are offered for your local area, so you always know what's happening outside</p>	<p>✓</p>
<p>Precise Comfort® Plus</p> <p>Holds your home's temperature to within 0.5 degree or less when used with premium Lennox® equipment</p>	<p>✓</p>



Convenience

- Touchscreen Operation:** The bright, clear screen is easy to read in any light, and easy to operate with just one finger.
- One-Touch Away Mode:** One touch or remote click will put your system into One-Touch Away Mode, reducing system use and energy consumption when no one is home.
- Weather Data:** The iComfort Wi-Fi can display live weather alerts and a five-day forecast, so you're always prepared for what's happening outside.
- Screen Saver:** Customize your thermostat by uploading a family picture.

1(B): transmitter means connected to the controller adapted to transmit location data to a remote device physically remote from the controller, so that a location response is induced at the remote device; and;- For instance, the '739 Accused Products uses a Wi-Fi network connection for transmitting location data to a remote weather service device.

1. Press and release **Wi-Fi** in the lower left corner of the HOME screen

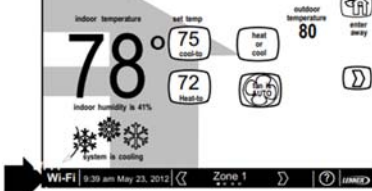

Figure 34. Press Wi-Fi

2. Press the **Wi-Fi disable** button to enable Wi-Fi.

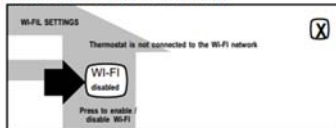

Figure 35. Enable Wi-Fi

3. The **User Agreement** screens will appear next. Press **next** as many times as necessary; then press **accept** after reading the User Agreement.

ESTABLISHING A WI-FI CONNECTIONS
There are two methods to setup your Wi-Fi connection. Select either **NETWORK SETTINGS** or **connection status**.

Method 1 — Network Settings Method

1. Press **NETWORK SETTINGS**; this screen shows a graphical view of buttons representing **OPEN** and **SECURE** Wi-Fi networks and a button for adding a network.

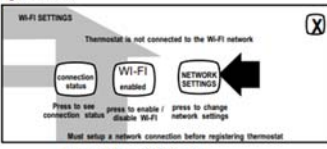

Figure 36. Enable Wi-Fi

- **Open** connection which requires no password.
- **Secure** connection which requires Wi-Fi password (security key).
- **Add a network** is required when Wi-Fi identification (SSID) is being hidden (not broadcasting). You will need to know the Wi-Fi network name (SSID), security encryption type (if enabled), and security password (if security encryption is enabled).

2. When selecting a:

- **unsecured** connection a screen will appear with two options, **connect** and **router info**. Press **connect** to continue.
- **secured** connection a screen will appear requesting the Wi-Fi network password (security key). There are two options to select from which are **connect** and **router info**. Using the on-screen keyboard, enter the password (security key) and then press **connect** to continue.

Page 21 iComfort Wi-Fi® 7-Day Programmable Communicating Thermostat

Registering the Thermostat

REGISTRATION FOR ONLINE ACCESS

1. From the **WI-FI SETTINGS** screen, press either the **thermostat not registered** icon or the **connection status** icon and select the **server** icon.

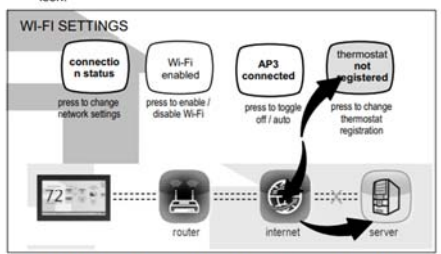

2. Enter homeowner email address and press the register button.

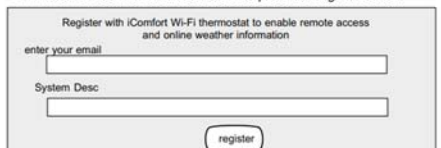

3. A pop-up screen will appear asking if the email address below is correct? Verify the email address is correct and press **yes**.

4. Another pop-up screen will appear notifying the user to check their email.

An email has been sent to xxxxxxxx@lennoxind.com with instructions on how to register your thermostat. If you haven't received the email, please check your spam folder and make sure that your email address is correct.

NOTE - If the email address originally entered is incorrect, return to the thermostat registered screen and reenter the correct information and press register.

5. After the server sends the email with the network link, registration and account creation must be completed from the homeowners personal computer.

NOTE - Time from pushing the registration button on the thermostat and receiving the consumer portal register link from your email on your computer is normally from 5 to 15 minutes depending on Internet speed and traffic.

NOTE - Registration cannot be completed from any mobile device.

6. After registration has been completed, press the connection status icon to verify the connection was successful. If the connection is successful the server icon background will be green.



7. After successful connection to the server is completed, the **firmware update** button will appear. The default setting is set to auto. If any firmware updates are available they will immediately start downloading and update the thermostat. The thermostat will reboot itself after the update is completed. Updates are done in the background and will not impair normal thermostat operations.

This auto update feature can be disabled by pressing the firmware update button to toggle to OFF however this is not recommended.

Page 25 iComfort Wi-Fi® 7-Day Programmable Communicating Thermostat

I(C): location response is storage of the location data at the remote device and correlation of the physical location to location response data stored at or available to the remote device or created by processing of location data at the remote device, whereafter location response data is transmitted from the remote device to the controller;-For instance, the '738 Accused Products receive local weather information based on its postal /zip code from remote weather service devices and provide the outdoor temperature and weather forecast on the

screen display. The remote weather service device provides the weather forecast based on the zip code of an area.

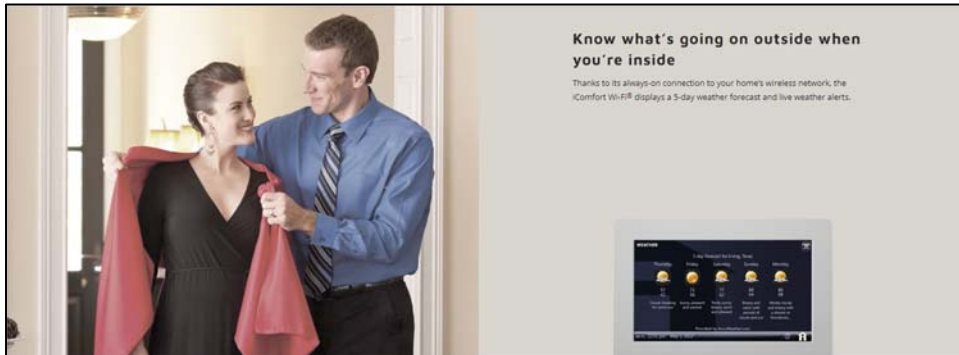

WEATHER

1. Touch the **weather icon** on the Home screen (see figure 1 on page 3) to view the **WEATHER** screen. Figure 26 shows a typical 5-day forecast screen.
2. Use **"X"** button to return to the Home screen.

Thursday	Friday	Saturday	Sunday	Monday
85 60	88 61	85 62	88 61	86 60
Clouds breaking for some sun	Sunny, pleasant and warmer	Partly sunny and Hot	Partly sunny and Hot	Partly sunny and Hot

Provided by AccuWeather .com

Wi-Fi | 9:39 am May 23, 2012

Figure 26. Typical Weather Screen

83. At least as early as of the date of the filing of the Complaint, Defendant has had actual knowledge of the '739 Patent.

84. Additionally, Defendant contributorily infringes at least one or more claims of the '739 Patent by providing the '739 Accused Products and/or software components thereof, that embody a material part of the claimed inventions of the '739 Patent, that are known by Defendant to be specially made or adapted for use in an infringing manner, and are not staple

articles with substantial non-infringing uses. The '739 Accused Products are specially designed to infringe at least one or more claims of the '739 Patent, and their accused components have no substantial non-infringing uses. In particular, on information and belief, the software modules and code that implement and perform the infringing functionalities identified above are specially made and adapted to carry out said functionality and do not have any substantial non-infringing uses.

85. At least as early as the filing and/or service of this Complaint, Defendant's infringement of the '739 Patent was and continues to be willful and deliberate, entitling Rosen to enhanced damages.

86. Additional allegations regarding Defendant's knowledge of the '739 Patent and willful infringement will likely have evidentiary support after a reasonable opportunity for discovery.

87. Defendant's infringement of the '739 Patent is exceptional and entitles Rosen to attorneys' fees and costs incurred in prosecuting this action under 35 U.S.C. § 285.

88. Rosen is in compliance with any applicable marking and/or notice provisions of 35 U.S.C. § 287 with respect to the '739 Patent.

89. Rosen is entitled to recover from Defendant all damages that Rosen has sustained as a result of Defendant's infringement of the '739 Patent, including, without limitation, a reasonable royalty.

COUNT IV: INFRINGEMENT OF U.S. PATENT NO. 7,156,318

90. Rosen incorporates by reference and re-alleges paragraphs 1-89 of this Complaint as if fully set forth herein

91. Defendant has infringed and is infringing, either literally or under the doctrine of

equivalents, the '318 Patent in violation of 35 U.S.C. § 271 *et seq.*, directly and/or indirectly, by making, using, offering for sale, or selling in the United States, and/or importing into the United States without authority or license, among other things, the Lennox iComfort Wi-Fi Thermostat, and other substantially similar products (“the '318 Accused Product”).

92. As just one non-limiting example, set forth below (with claim language in bold and italics) is exemplary evidence of infringement of Claim 1 of the '318 Patent in connection with the '318 Accused Products. This description is based on publicly available information. Rosen reserves the right to modify this description, including, for example, on the basis of information about the '318 Accused Products that it obtains during discovery

1: A programmable thermostat system for controlling space conditioning equipment comprising: - For instance, the '318 Accused Product is a programmable thermostat which controls the room temperature and humidity level (space conditioning equipment).

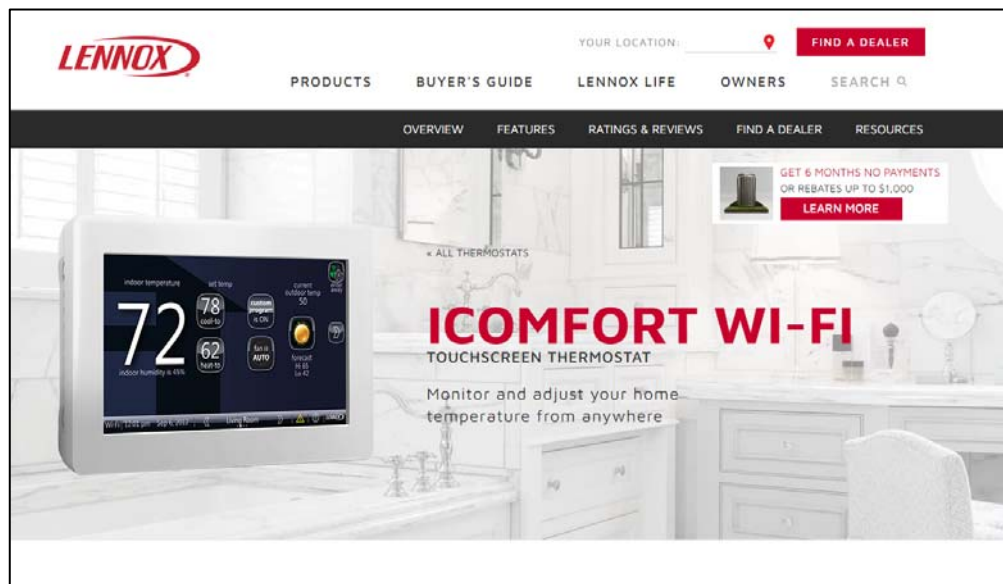

- This thermostat supports:
- Wireless bands 802.11b, 802.11g and 802.11n
 - Three languages (English, French, Spanish)
 - Air conditioning or heat pump units with up to four stages of heat / two stages of compressor operation (2 stages of heat pump heating, 2 stages of auxiliary back-up heating and 2 stages of emergency heating)
 - Variable-capacity / multiple-stage heat / cool and universal compatibility (gas/electric/heat pump/air conditioner).
 - Dual-fuel capable (iComfort®-enabled HP only) with two balance points.
 - Indoor air quality with time-based notification of consumables including media filters, UVC bulbs, humidifier pads and PureAir™ system catalyst service / replacement,
 - iHarmony® Zoning System (2 - 4 zones)
 - Lennox iComfort® Equipment Interface Module (Catalog number 10T50) (provides iComfort Wi-Fi® to non-communicating indoor unit,
 - Humidification measurement and control.
 - Dew point adjustment control
 - Humiditro® Enhanced Dehumidification Accessory (EDA)
 - Multiple-stage HVAC systems
 - Equipment maintenance reminders
 - Autochangeover mode – Permits control of heating, cooling, humidification, and dehumidification without user involvement
 - All Lennox branded communicating outdoor units contain a built-in outdoor temperature sensor.

1(A) at least one environmental condition sensor providing an electrical signal indicative of the ambient temperature of a conditioned space in which said environmental condition sensor is situated;— For instance, the '318 Accused Products include temperature sensors (environmental condition sensor). The sensors detect the current space temperature and displays the current indoor temperature (providing an electrical signal indicative of the ambient temperature of a conditioned space in which said environmental condition sensor is situated).

29	Critical	(Thermostat) The thermostat is reading an indoor temperature that is higher than 99°F. The thermostat will not allow any heating operation to begin until it senses a temperature lower than 99°F.	Indoor temperature rose above 99°F during a heating or cooling demand. Heating operation is not allowed. Check to ensure that Heating Equipment is not stuck ON (reversing valve, etc.). Check the accuracy of the thermostat temperature sensor. Select cooling system mode to cool the indoor space.
30	Moderate	(Thermostat) The thermostat is reading an indoor temperature that is lower than 40°F. The thermostat will not allow any cooling operation to begin until it senses a temperature higher than 40°F.	Indoor Temp fell below 40°F. Cooling operation is not allowed. Check to ensure that cooling equipment is not stuck ON. Check accuracy of the thermostat temperature sensor . Select heating system mode to heat the indoor space to above 40°F.

1(B): a transparent touch pad juxtaposed with a liquid crystal display to constitute a touch screen for interactive interface with a user; - For instance, the '318 Accused Products

include a transparent touchscreen.



Alerts and Reminders: Not only will your iComfort Wi-Fi monitor itself with advanced diagnostics, but it can also send you and your dealer alerts and emails if the system needs service or maintenance.

Smart Energy Use: Seasonal schedules save energy all year long, while One-Touch Away Mode helps your system use less when no one is home.

App-Enabled: Free to download for Apple and Android devices, the iComfort App is like a touchscreen window into your home comfort. Whether you're on the road or on the couch, simply start the app to check and change your temperature with only a finger.

Convenience

Touchscreen Operation: The bright, clear screen is easy to read in any light, and easy to operate with just one finger.

One-Touch Away Mode: One touch or remote click will put your system into One-Touch Away Mode, reducing system use and energy consumption when no one is home.

Weather Data: The iComfort Wi-Fi can display live weather alerts and a five-day forecast, so you're always prepared for what's happening outside.

Screen Saver: Customize your thermostat by uploading a family picture.

Remote Access: Once connected to the Cloud through your wireless network, your iComfort Wi-Fi can be adjusted from anywhere in the world via your smartphone, tablet, laptop or other web-enabled device.

Innovation

App-Enabled: Free to download for Apple and Android devices, the iComfort App is like a touchscreen window into your home comfort. Whether you're on the road or on the couch, simply start the app to check and change your temperature with only a finger.

Comfort

Perfect Air: The iComfort Wi-Fi works with your Lennox® system to carefully control both temperature and humidity, filling your home with perfectly comfortable air.

Peace of Mind: Like all Lennox equipment, the iComfort Wi-Fi is built to deliver more, and built to last. So you'll enjoy reliable comfort season after season.

Precise Control: For the ultimate in home comfort, pair the iComfort Wi-Fi thermostat with iHarmony Zoning to customize the temperature in any area of your home. Zoning not only helps eliminate hot and cold spots, but also helps you save money on utility bills by ensuring that you are not heating or cooling seldom-used areas of your home, like guest rooms or media rooms.

User Features and Help (?) Screens

From the Home screen, touch the (?) button to access the Features screen. The Features screen (figure 3) allows you access to edit programs, system settings, zoning settings, alerts, reminders, service and help (?).

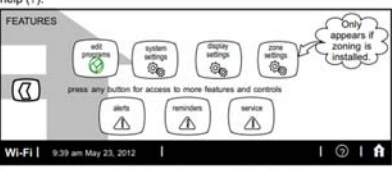

Figure 3. Features Screen - Indoor Settings

EDIT PROGRAMS (SCHEDULE)

Touch **edit programs** button (see fig. 3). Figure 4 shows the EDIT PROGRAMS screen.

Edit the "season programs" to reflect your preferences. (The **Save energy** program uses high-efficiency Energy Star settings to promote energy conservation.)

- **select programs** - Select a preset program; or touch and hold any button to enable the keyboard to change program names to suit your preferences.
- **select days** - Select week/weekend, individual days, all 7 days.
- **time** - Use up/down arrows to change time in 15 minute increments.
- **cool- and heat-to** - Use up/down arrows to change temperature in 1 degree increments.
- **fan mode** - Select on, auto, or circulate.

In the example in Figure 4, the evening time has been disabled by touching and holding the time button for that time period until time is replaced with **add setting**. To re-enable, touch **add setting** that time period. Use the **restore** button to restore defaults for the preset programs. If no additional adjustment are made to any programs, touch "X" button to exit. If changes are made to any programs then touch the **save** button and then touch X to exit this screen and return to the FEATURES screen.

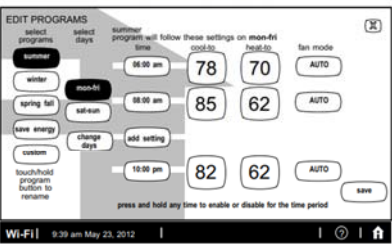

Figure 4. EDIT PROGRAMS Screen

TURN PROGRAMMING ON

If the programming is OFF, touch the system mode button (shown in figure 5, labeled **heat or cool**) to open the manual settings menu. **Programs** is the final selection in this menu. Select **programs** to display the program settings menu. (The menu will disappear if you don't make a selection within a few seconds). Select an option (e.g. **spring/fall**). The system mode button will display the selected program (e.g. **spring...program is ON**).

Touchscreen

Features a large, easy-to-use display with adjustable brightness



I(C): a processor, said processor including;-For instance, the '318 Accused Products includes a processor.



I(C)(1): a central processing unit;-For instance, in the '318 Accused Products the processor, includes a central processing unit.

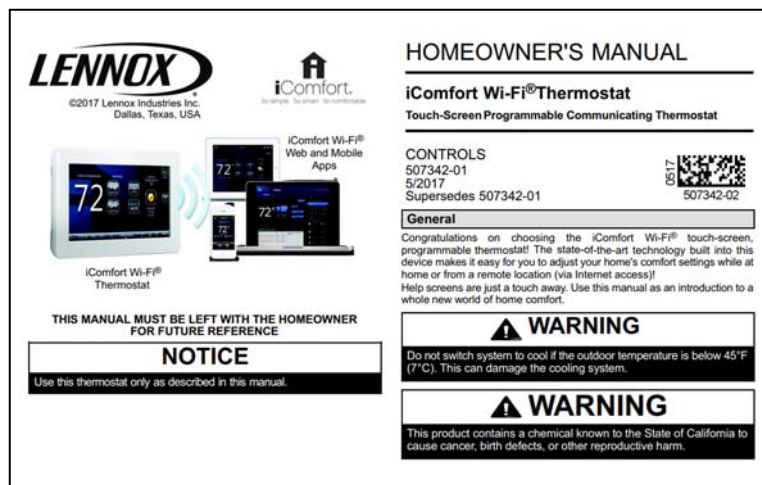

I(C)(2): a real time clock;- For instance, in the '318 Accused Products the processor, includes a real time clock.

Adjusting System Setting

SET TIME AND DATE

Use the arrows to select **Time and Date**; touch **edit** to proceed to the "Set current time and date" screen.

When "Time and Date" screen appears, enter the correct date as follows:

- Use the left and right arrows to change the month and year.
- Touch a day of the month to select it.
- Touch on the hour or minute; up down arrows appear to allow change.
- Touch the **am/pm** field to toggle it between am and pm.
- When the correct date and time is set, touch **save** to save settings and return to previous settings screen.

Touch **next** to continue to next screen.

I(C)(3): a memory coupled to said central processing unit for storing program and data information; and;-For instance, in the '318 Accused Products the application processor includes internal memory.

 **WARNING**

This is a 24VAC Class 2 thermostat. Do not install on voltages higher than 30VAC.
Do not switch system to cool if the outdoor temperature is below 45°F (7°C). This can damage the cooling system.

iComfort Wi-Fi® Thermostat - Technical Description and Features

The 24VAC iComfort Wi-Fi® thermostat is an electronic communicating, color display touchscreen and 7-day programmable thermostat. It stores system parameters and settings in non-volatile memory (i.e., it retains data when electrical power fails or is turned off).

The iComfort Wi-Fi® thermostat can connect to online services via the Internet through the homeowner's Wi-Fi access point. After online registration is completed, the system may then be accessed by the homeowner from anywhere using a remote Internet connection via computer or personal communicating device.

Refer to page 37 for information on making connections to the thermostat.

I(C)(4): an input/output unit coupled between said processor and said touch screen for carrying out information transfer there between, said input/output unit further including;-For instance, the '318 Accused Products include an I/O unit for providing coupling between processor and LCD touch screen interface.

This thermostat supports:

- Wireless bands 802.11b, 802.11g and 802.11n
- Three languages (English, French, Spanish)
- Air conditioning or heat pump units with up to four stages of heat / two stages of compressor operation (2 stages of heat pump heating, 2 stages of auxiliary back-up heating and 2 stages of emergency heating)
- Variable-capacity / multiple-stage heat / cool and universal compatibility (gas/electric/heat pump/air conditioner).
- Dual-fuel capable (iComfort®-enabled HP only) with two balance points.
- Indoor air quality with time-based notification of consumables including media filters, UVC bulbs, humidifier pads and PureAir™ system catalyst service / replacement,
- iHarmony® Zoning System (2 - 4 zones)
- Lennox iComfort® Equipment Interface Module (Catalog number 10T50) (provides iComfort Wi-Fi® to non-communicating indoor unit,
- Humidification measurement and control.
- Dew point adjustment control
- Humiditrol® Enhanced Dehumidification Accessory (EDA)
- Multiple-stage HVAC systems
- Equipment maintenance reminders
- Autochangeover mode -- Permits control of heating, cooling, humidification, and dehumidification without user involvement
- All Lennox branded communicating outdoor units contain a built-in outdoor temperature sensor.

Figure 13. Registration Screen

NOTE - This following information is customer setup instructions and is shown here to allow the installer to help walk the customer through the setup process.

After registering through your iComfortWi-Fi® thermostat interface, go to the homeowner's computer and locate the email sent from the server.

NOTE - If the customer has already setup an account, click the "Click Here" button to access that account.

Click on the Register link; the screen (to the left) will appear. Fill in the User Name and Password fields and check the agree to terms and conditions box. Click **Create User** button.

507341-02 12

Adding Non-Communicating Outdoor Unit and Accessories

OUTDOOR UNIT (AIR CONDITIONER OR HEAT PUMP)

To add (or remove) an outdoor unit that is not iComfort®-enabled, you must be at the "Add or Remove Non-communicating equipment?" screen.

1. Touch the **yes** button next to **Add or Remove Non-communicating equipment?**
2. In the "non-communicating device list" screen, use the arrows to highlight **Outdoor Unit Type** and touch **edit**.
3. Touch one of the radio buttons to select a 1-or 2-stage air conditioner unit or a 1-or 2-stage heat pump unit; touch **save**.
4. Use arrows to highlight any red colored text in the device list (e.g. select **Outdoor Unit Capacity**; text turns white). Touch **edit**.

5. Use either the up or down arrows to display the correct size outdoor unit. Touch **save** to continue.

NOTE - If the defaults are correct, you do not have to make any changes, but you must touch **save. When all red text is gone, the **back** button will appear; touch it to return to the "Add or Remove Non-communicating equipment?" screen.**

ADDING A HUMIDIFIER

Before adding a humidifier, be sure that the:

- Humidifier is wired to the furnace or air handler control as shown on the Optional Accessories wiring diagram (see page 42),
- Entire system is wired, powered up, and the thermostat has detected the system's installed communicating devices, and you are at the "Add or Remove Non-communicating equipment?" screen.

To add (or remove) a humidifier:

1. Touch the **yes** button on this screen.
2. In the "non-communicating device list" screen, use the arrows to highlight **Humidifier** (note the current value, **Not Installed**) and touch **edit**.
3. Touch one of the radio buttons to select the type of humidifier (or select **Not Installed**, if removing humidifier); touch **save**.
4. The previous screen returns, but the current value now shows your selection. Touch the **back** button.
5. The "Add or Remove..." screen reappears with your addition shown in the system devices list. At this point, you may add more equipment (touch **yes**) or if finished, touch the **next** button to advance to the "Adjust a setting..." screen (see page 15).

NOTE - Adding humidity regulating non-communicating devices may be a 2-step procedure:

- **First** the device must be installed and wired. After the humidifier is installed, the setting under the "System" mode "Humidification Control Mode" defaults to "Basic".
- **Second**, if you want another mode, i.e. Precision, Basic Dew Point, or Precision Dew Point, the device requires further configuration (see page 15).

ADDING HUMIDITROL® OR AN AUXILIARY DEHUMIDIFIER

Before adding a dehumidifier, be sure that:

- the dehumidifier is wired to the furnace or air handler control as shown on the Optional Accessories wiring diagram (see page 42),
- the entire system is wired, powered up, and the thermostat has detected the system's installed communicating devices, and you are at the "Add or Remove Non-communicating equipment?" screen.

To add (or remove) a dehumidifier, you must be at the "Add or Remove Non-communicating equipment?" screen.

1. Touch the **yes** button on this screen.
2. In the "non-communicating device list" screen, use the arrows to highlight **Dehumidifier** and touch **edit**. Note the current value (e.g. Not Installed).
3. Touch one of the radio buttons to select the type of dehumidifier (or select **Not Installed**, if removing dehumidifier); touch **save**.
4. When you scroll to the Dehumidifier device, (Note the current value, e.g. Humiditrol.) Click **back** to return to the "Add or Remove..." screen.
5. The "Add or Remove..." screen reappears with your addition shown in the system devices list. At this point, you may add more equipment (touch **yes**) or if finished, touch the **next** button to advance to the "Adjust a setting..." screen.

NOTE - Adding humidity regulating non-communicating devices may be a 2-step procedure:

- **First** the device must be installed and wired. After the dehumidifier is installed, the setting under the "System" mode "Dehumidification Control Mode" defaults to "Basic".
- **Second**, set Humiditrol® comfort adjust overcooling and the min/max dehumidification setpoints if desired (see page 16).

While iComfort Wi-Fi is designed for use with premium Lennox® equipment, the iComfort Wi-Fi Flex can work with almost any system. So no matter what type of home heating and cooling equipment you have, you can enjoy the innovation of Lennox, and a more comfortable, energy-efficient home.



	iComfort Wi-Fi®	iComfort Wi-Fi® Flex
Compatible with Lennox®-brand communicating heating and cooling equipment	●	
Compatible with Lennox-brand non-communicating equipment and most other brands of heating and cooling equipment		●
Touchscreen Operation	●	●
Remote Access	●	●
7-Day Programmable	●	●
One-Touch Away	●	●
5-Day Weather Forecast	●	●
Customizable Reminders	●	●
Automatic Updates	●	●
Dual-Fuel Compatible	●	●
Humidity Control	●	●
Diagnostics and Alerts	Highly Advanced	Limited Reporting
Compatible with zoned systems	Designed for integration with iHarmony® Zoning System	
Exchanges information with heating and cooling equipment	Uses Lennox Precise Comfort® Technology to optimize system performance	
Warranty	5-Year Limited	5-Year Limited

1(C)(4)(a): a sensor input coupled to each said environmental condition sensors for receiving said electrical signal therefrom; and;-For instance, the '318 Accused Products include thermostat sensors that sense the current space temperature (receiving said electrical signal).

29	Critical	(Thermostat) The thermostat is reading an indoor temperature that is higher than 99°F. The thermostat will not allow any heating operation to begin until it senses a temperature lower than 99°F.	Indoor temperature rose above 99°F during a heating or cooling demand. Heating operation is not allowed. Check to ensure that Heating Equipment is not stuck ON (reversing valve, etc.). Check the accuracy of the thermostat temperature sensor. Select cooling system mode to cool the indoor space.
30	Moderate	(Thermostat) The thermostat is reading an indoor temperature that is lower than 40°F. The thermostat will not allow any cooling operation to begin until it senses a temperature higher than 40°F.	Indoor Temp fell below 40°F. Cooling operation is not allowed. Check to ensure that cooling equipment is not stuck ON. Check accuracy of the thermostat temperature sensor. Select heating system mode to heat the indoor space to above 40°F.

1(C)(4)(b): a control output coupled to the space conditioning equipment for issuing control signals thereto; and;-For instance, the '318 Accused Products control the heating and cooling system (space conditioning equipment).

iComfort Wi-Fi® Thermostat

The communicating iComfort Wi-Fi® thermostat is an electronic 7-day programmable touch-screen thermostat with a color display. It also offers enhanced capabilities which include: humidification measurement and control, dew point adjustment control, dehumidification measurement and control, Humiditrol® Enhanced Dehumidification Accessory (EDA) compatibility, and equipment maintenance reminders. The thermostat's autochangeover mode permits control of heating, cooling, humidification, and dehumidification without user involvement.

Figure 13. Registration Screen

NOTE - This following information is customer setup instructions and is shown here to allow the installer to help walk the customer through the setup process.

After registering through your iComfort Wi-Fi® thermostat interface, go to the homeowner's computer and locate the email sent from the server.

NOTE - If the customer has already setup an account, click the "Click Here" button to access that account.

Click on the Register link; the screen (to the left) will appear. Fill in the User Name and Password fields and check the agree to terms and conditions box. Click **Create User** button.

507341-02 12

5. Use either the up or down arrows to display the correct size outdoor unit. Touch **save** to continue.

NOTE - If the defaults are correct, you do not have to make any changes, but you must touch **save**. When all red text is gone, the **back** button will appear; touch it to return to the "Add or Remove Non-communicating equipment?" screen.

ADDING A HUMIDIFIER

Before adding a humidifier, be sure that the:

- Humidifier is wired to the furnace or air handler control as shown on the Optional Accessories wiring diagram (see page 42).
- Entire system is wired, powered up, and the thermostat has detected the system's installed communicating devices, and you are at the "Add or Remove Non-communicating equipment?" screen.

To add (or remove) a humidifier:

- Touch the **yes** button on this screen.
- In the "non-communicating device list" screen, use the arrows to highlight **Humidifier** (note the current value, **Not Installed**) and touch **edit**.
- Touch one of the radio buttons to select the type of humidifier (or select **Not Installed**, if removing humidifier); touch **save**.
- The previous screen returns, but the current value now shows your selection. Touch the **back** button.
- The "Add or Remove..." screen reappears with your addition shown in the system devices list. At this point, you may add more equipment (touch **yes**) or if finished, touch the **next** button to advance to the "Adjust a setting..." screen (see page 15).

NOTE - Adding humidity regulating non-communicating devices may be a 2-step procedure:

- First** the device must be installed and wired. After the humidifier is installed, the setting under the "System" mode "Humidification Control Mode" defaults to "Basic".
- Second**, if you want another mode, i.e. Precision, Basic Dew Point, or Precision Dew Point, the device requires further configuration (see page 15).

ADDING HUMIDITROL® OR AN AUXILIARY DEHUMIDIFIER

Before adding a dehumidifier, be sure that:

- the dehumidifier is wired to the furnace or air handler control as shown on the Optional Accessories wiring diagram (see page 42).
- the entire system is wired, powered up, and the thermostat has detected the system's installed communicating devices, and you are at the "Add or Remove Non-communicating equipment?" screen.

To add (or remove) a dehumidifier, you must be at the "Add or Remove Non-communicating equipment?" screen.

- Touch the **yes** button on this screen.
- In the "non-communicating device list" screen, use the arrows to highlight **Dehumidifier** and touch **edit**. Note the current value (e.g. Not Installed).
- Touch one of the radio buttons to select the type of dehumidifier (or select **Not Installed**, if removing dehumidifier); touch **save**.
- When you scroll to the Dehumidifier device, (Note the current value, e.g. Humiditrol.) Click **back** to return to the "Add or Remove..." screen.
- The "Add or Remove..." screen reappears with your addition shown in the system devices list. At this point, you may add more equipment (touch **yes**) or if finished, touch the **next** button to advance to the "Adjust a setting..." screen.

NOTE - Adding humidity regulating non-communicating devices may be a 2-step procedure:

- First** the device must be installed and wired. After the dehumidifier is installed, the setting under the "System" mode "Dehumidification Control Mode" defaults to "Basic".
- Second**, set Humiditrol® comfort adjust overcooling and the min/max dehumidification setpoints if desired (see page 16).

1(D): a control program stored in said memory for causing said central processing unit to communicate through said input/output unit to selectively;-For instance, the '318 Accused Products enable a user to set different system modes which are stored on the thermostat.



WARNING

This is a 24VAC Class 2 thermostat. Do not install on voltages higher than 30VAC.

Do not switch system to cool if the outdoor temperature is below 45°F (7°C). This can damage the cooling system.

iComfort Wi-Fi® Thermostat - Technical Description and Features

The 24VAC iComfort Wi-Fi® thermostat is an electronic communicating, color display touchscreen and 7-day programmable thermostat. It stores system parameters and settings in non-volatile memory (i.e., it retains data when electrical power fails or is turned off).

The iComfort Wi-Fi® thermostat can connect to online services via the Internet through the homeowner's Wi-Fi access point. After online registration is completed, the system may then be accessed by the homeowner from anywhere using a remote Internet connection via computer or personal communicating device.

Refer to page 37 for information on making connections to the thermostat.

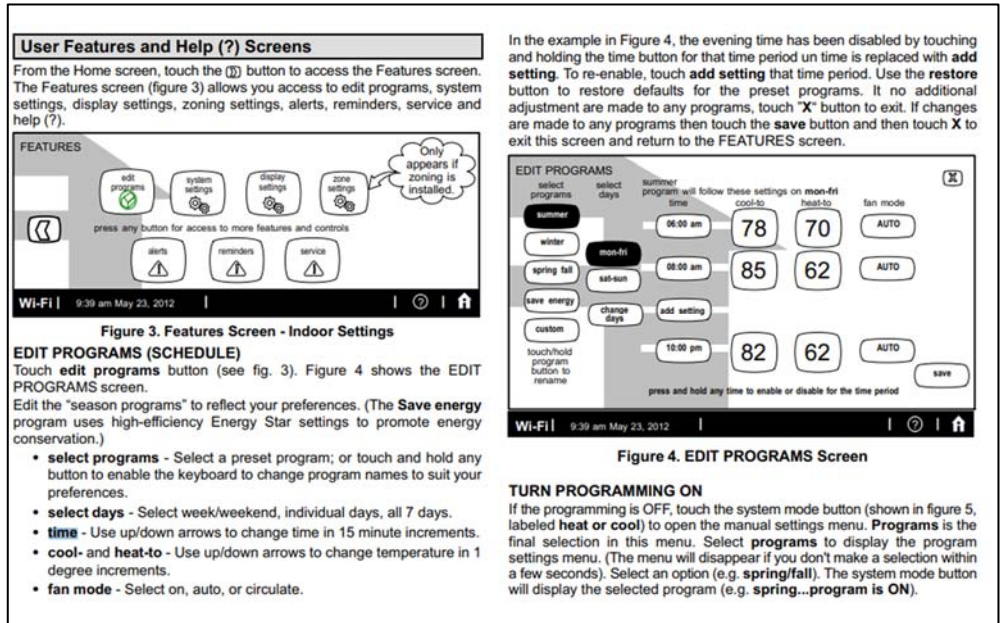

1(D)1: establish on said liquid crystal display;-For instance, the '318 Accused Products include an LCD touchscreen for display purpose..



1(D)1(a): a representation of a first virtual button at a first predetermined position on the liquid crystal display; and;-For instance, the '318 Accused Products LCD screen displays various icons (a first virtual button).

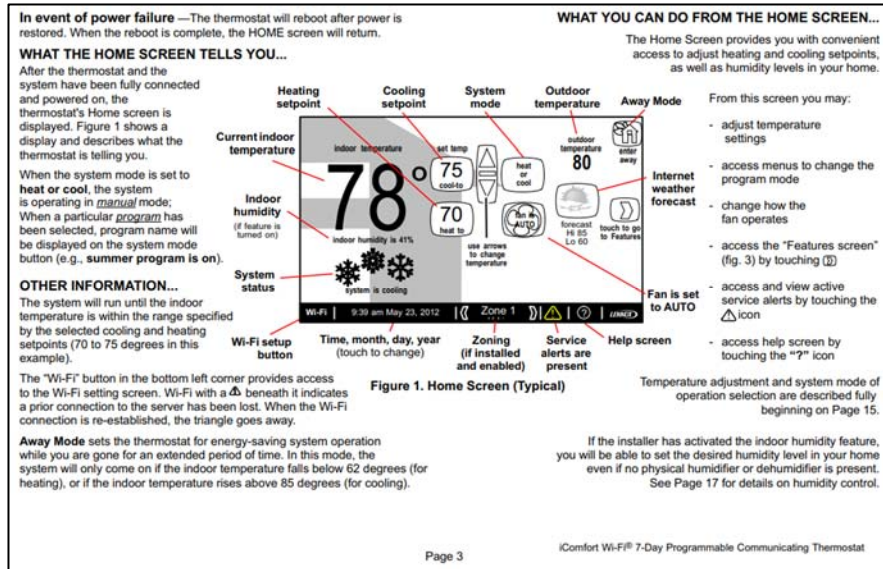

1(D)(1)(b): a first legend indicative of a first control function of said thermostat, which first control function is for controlling a first space conditioning equipment component, which first control function is active when the first legend is viewable;;-For instance, in the '318 Accused Products, the "system is heating" graphic represents that the thermostat is in Heating mode.

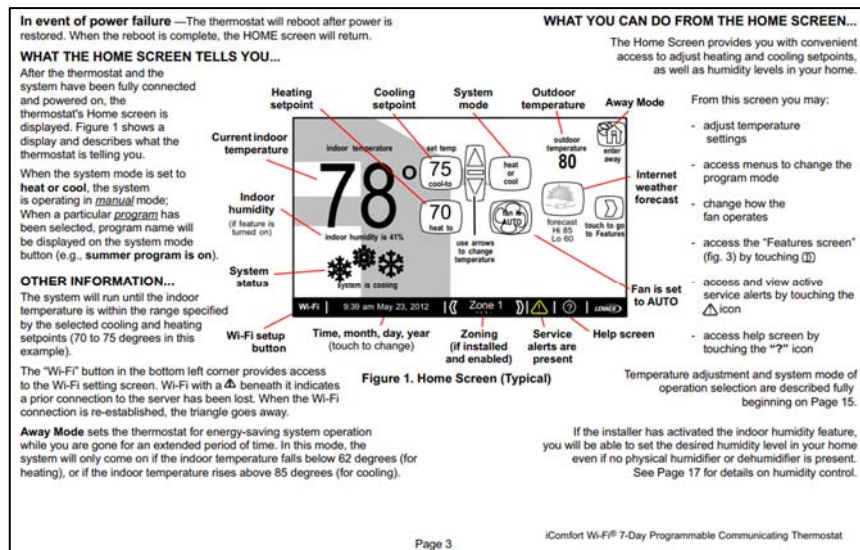



1(D)(2): read the position on the touch pad juxtaposed with said first predetermined position on said liquid crystal display to determine if the representation of said first virtual button has been touched;-For instance, in the '318 Accused Products, when a user touches the adjustable temperature arrow on the touch screen of the thermostat (first virtual button has been touched), a cooling/heating signal is sent to the equipment.

In event of power failure —The thermostat will reboot after power is restored. When the reboot is complete, the HOME screen will return.

WHAT THE HOME SCREEN TELLS YOU...
 After the thermostat and the system have been fully connected and powered on, the thermostat's Home screen is displayed. Figure 1 shows a display and describes what the thermostat is telling you.
 When the system mode is set to **heat or cool**, the system is operating in **manual** mode. When a particular **program** has been selected, program name will be displayed on the system mode button (e.g., **summer program** is on).

OTHER INFORMATION...
 The system will run until the indoor temperature is within the range specified by the selected cooling and heating setpoints (70 to 75 degrees in this example).
 The "Wi-Fi" button in the bottom left corner provides access to the Wi-Fi setting screen. Wi-Fi with a beneath it indicates a prior connection to the server has been lost. When the Wi-Fi connection is re-established, the triangle goes away.

Away Mode sets the thermostat for energy-saving system operation while you are gone for an extended period of time. In this mode, the system will only come on if the indoor temperature falls below 62 degrees (for heating), or if the indoor temperature rises above 85 degrees (for cooling).

WHAT YOU CAN DO FROM THE HOME SCREEN...
 The Home Screen provides you with convenient access to adjust heating and cooling setpoints, as well as humidity levels in your home.
 From this screen you may:
 - adjust temperature settings
 - access menus to change the program mode
 - change how the fan operates
 - access the "Features screen" (fig. 3) by touching
 - access and view active service alerts by touching the
 - access help screen by touching the "?" icon
 - Temperature adjustment and system mode of operation selection are described fully beginning on Page 15.
 If the installer has activated the indoor humidity feature, you will be able to set the desired humidity level in your home even if no physical humidifier or dehumidifier is present. See Page 17 for details on humidity control.

Figure 1. Home Screen (Typical)

Page 3 iComfort Wi-Fi® 7-Day Programmable Communicating Thermostat

1(D)(3): if the first virtual button has been touched;-For instance, the '318 Accused Products provide for a user to adjust the temperature by touching the adjustable temperature arrows.

In event of power failure —The thermostat will reboot after power is restored. When the reboot is complete, the HOME screen will return.

WHAT THE HOME SCREEN TELLS YOU...
 After the thermostat and the system have been fully connected and powered on, the thermostat's Home screen is displayed. Figure 1 shows a display and describes what the thermostat is telling you.

When the system mode is set to **heat or cool**, the system is operating in *manual* mode. When a particular *program* has been selected, program name will be displayed on the system mode button (e.g., **summer program is on**).

OTHER INFORMATION...
 The system will run until the indoor temperature is within the range specified by the selected cooling and heating setpoints (70 to 75 degrees in this example).

The "Wi-Fi" button in the bottom left corner provides access to the Wi-Fi setting screen. Wi-Fi with a  beneath it indicates a prior connection to the server has been lost. When the Wi-Fi connection is re-established, the triangle goes away.

Away Mode sets the thermostat for energy-saving system operation while you are gone for an extended period of time. In this mode, the system will only come on if the indoor temperature falls below 62 degrees (for heating), or if the indoor temperature rises above 85 degrees (for cooling).

WHAT YOU CAN DO FROM THE HOME SCREEN...
 The Home Screen provides you with convenient access to adjust heating and cooling setpoints, as well as humidity levels in your home.

From this screen you may:



- adjust temperature settings
- access menus to change the program mode
- change how the fan operates
- access the "Features screen" (fig. 3) by touching 
- access and view active service alerts by touching the  icon
- access help screen by touching the "?" icon

Figure 1. Home Screen (Typical)



Page 3

iComfort Wi-Fi® 7-Day Programmable Communicating Thermostat

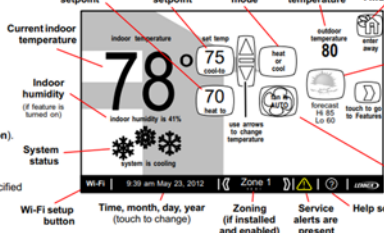

1(D)(3)(a): determining that the thermostat has been directed to control a second space conditioning equipment component;- For instance, the '318 Accused Products allows a user to set different modes by touching the virtual buttons.

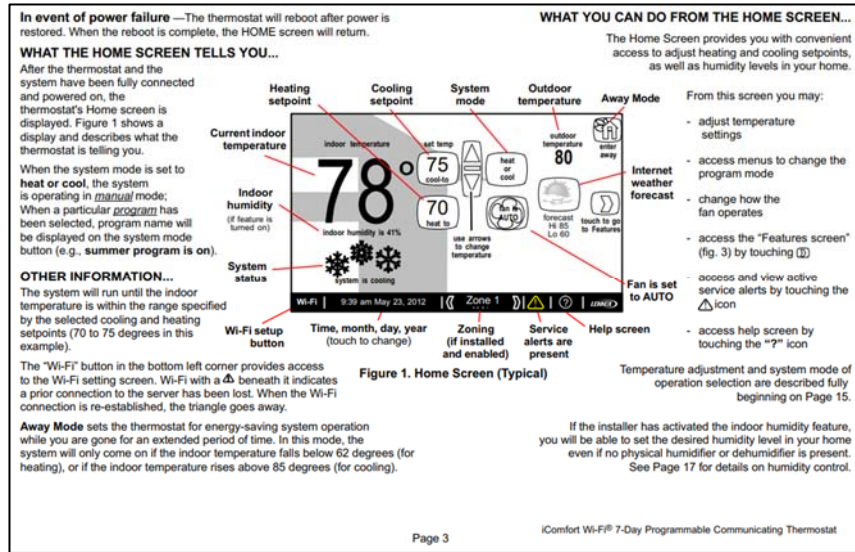

I(D)(3)(b): activating a second control function for controlling the second space conditioning equipment component; and—For instance, the '318 Accused Products include the functionality to activate a second control function for controlling the second space conditioning equipment, such as the Cooling mode.

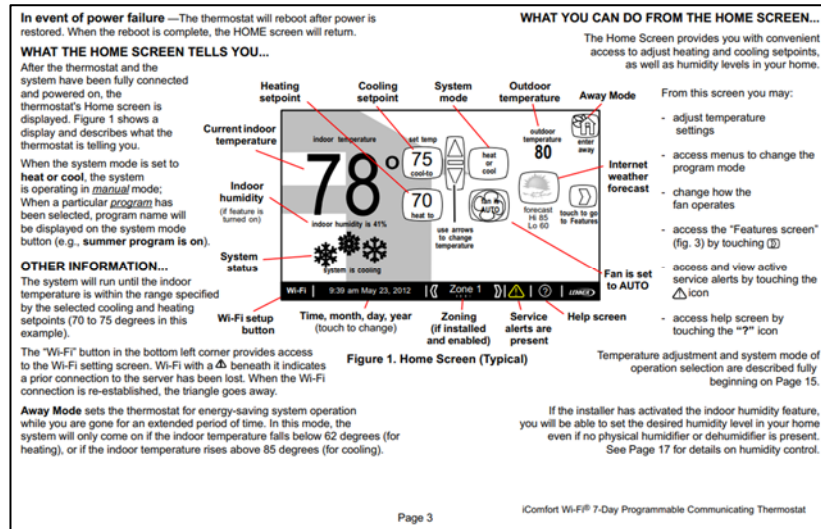

I(D)(3)(c): displaying on said liquid crystal display a second legend indicative of said second control function of said thermostat, which second control function is for controlling the second space conditioning equipment component, which second control function is active when the second legend is viewable.—For instance, the '318 Accused Products can display a

second legend indicative of a second control function, which in turn controls a second space conditioning equipment component.

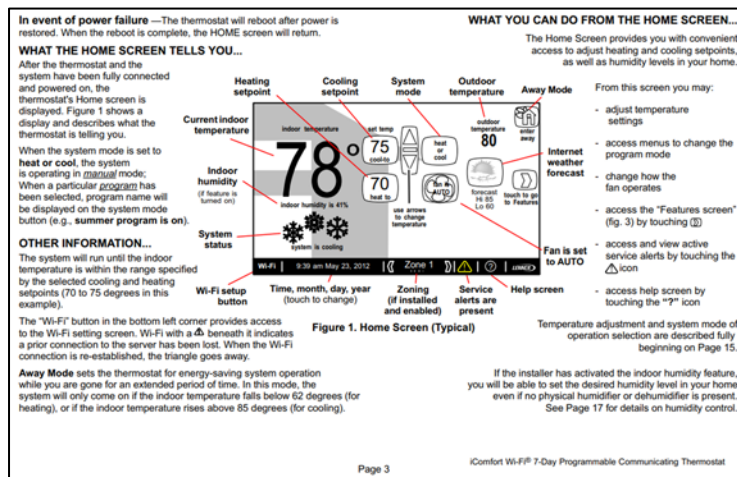
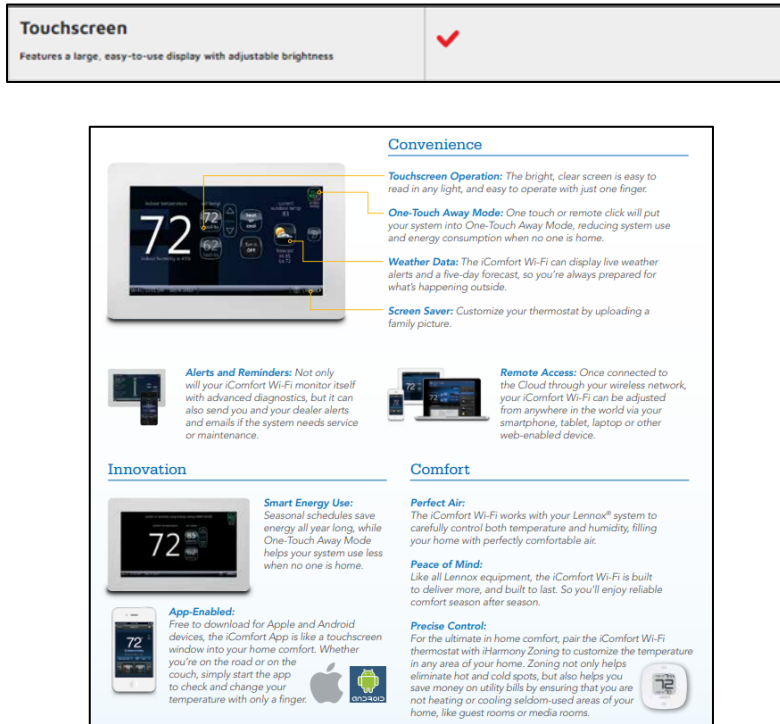

93. At least as early as of the date of the filing of the Complaint, Defendant has had actual knowledge of the '318 Patent.

94. Additionally, Defendant contributorily infringes at least one or more claims of the '318 Patent by providing the '318 Accused Products and/or software components thereof, that

embody a material part of the claimed inventions of the '318 Patent, that are known by Defendant to be specially made or adapted for use in an infringing manner, and are not staple articles with substantial non-infringing uses. The '318 Accused Products are specially designed to infringe at least one or more claims of the '318 Patent, and their accused components have no substantial non-infringing uses. In particular, on information and belief, the software modules and code that implement and perform the infringing functionalities identified above are specially made and adapted to carry out said functionality and do not have any substantial non-infringing uses.

95. At least as early as the filing and/or service of this Complaint, Defendant's infringement of the '318 Patent was and continues to be willful and deliberate, entitling Rosen to enhanced damages.

96. Additional allegations regarding Defendant's knowledge of the '318 Patent and willful infringement will likely have evidentiary support after a reasonable opportunity for discovery.

97. Defendant's infringement of the '318 Patent is exceptional and entitles Rosen to attorneys' fees and costs incurred in prosecuting this action under 35 U.S.C. § 285.

98. Rosen is in compliance with any applicable marking and/or notice provisions of 35 U.S.C. § 287 with respect to the '318 Patent.

99. Rosen is entitled to recover from Defendant all damages that Rosen has sustained as a result of Defendant's infringement of the '318 Patent, including, without limitation, a reasonable royalty.

COUNT V: INFRINGEMENT OF U.S. PATENT NO. 7,185,825

100. Rosen incorporates by reference and re-alleges paragraphs 1-99 of this Complaint

as if fully set forth herein.

101. Defendant has infringed and is infringing, either literally or under the doctrine of equivalents, the '825 Patent in violation of 35 U.S.C. § 271 *et seq.*, directly and/or indirectly, by making, using, offering for sale, or selling in the United States, and/or importing into the United States without authority or license, among other things, the Lennox iComfort Wi-Fi Thermostat, and other substantially similar products, (“the '825 Accused Products”).

102. As just one non-limiting example, set forth below (with claim language in bold and italics) is exemplary evidence of infringement of Claim 1 of the '825 Patent in connection with the '825 Accused Products. This description is based on publicly available information. Rosen reserves the right to modify this description, including, for example, on the basis of information about the '825 Accused Products that it obtains during discovery

1: A programmable thermostat for controlling space conditioning equipment comprising: - For instance, the '825 Accused Product is a programmable thermostat which controls the cooling and heating systems (space conditioning equipment).

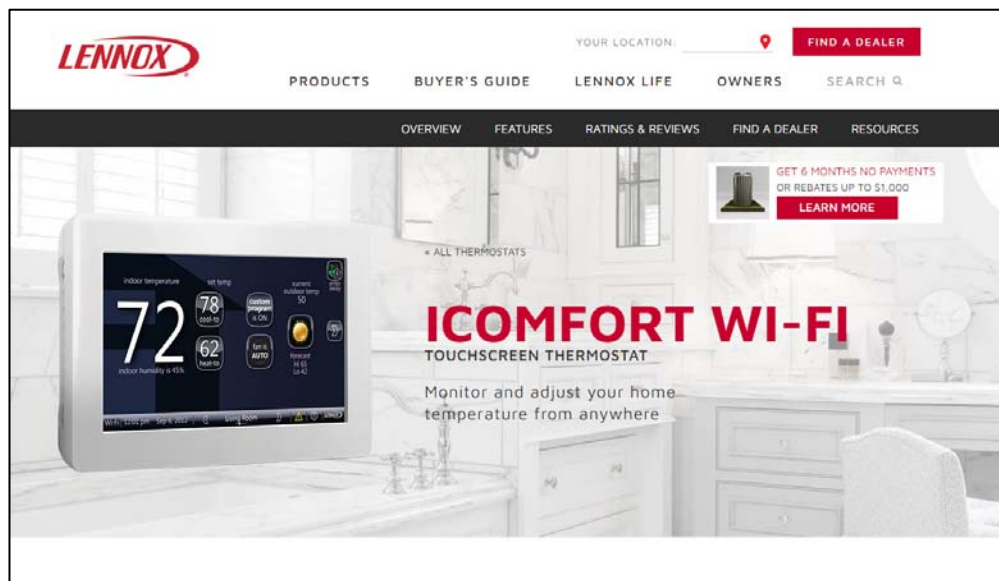

This thermostat supports:

- Wireless bands 802.11b, 802.11g and 802.11n
- Three languages (English, French, Spanish)
- Air conditioning or heat pump units with up to four stages of heat / two stages of compressor operation (2 stages of heat pump heating, 2 stages of auxiliary back-up heating and 2 stages of emergency heating)
- Variable-capacity / multiple-stage heat / cool and universal compatibility (gas/electric/heat pump/air conditioner).
- Dual-fuel capable (iComfort®-enabled HP only) with two balance points.
- Indoor air quality with time-based notification of consumables including media filters, UVC bulbs, humidifier pads and PureAir™ system catalyst service / replacement,
- iHarmony® Zoning System (2 - 4 zones)
- Lennox iComfort® Equipment Interface Module (Catalog number 10T50) (provides iComfort Wi-Fi® to non-communicating indoor unit,
- Humidification measurement and control.
- Dew point adjustment control
- Humiditrol® Enhanced Dehumidification Accessory (EDA)
- Multiple-stage HVAC systems
- Equipment maintenance reminders
- Autochangeover mode – Permits control of heating, cooling, humidification, and dehumidification without user involvement
- All Lennox branded communicating outdoor units contain a built-in outdoor temperature sensor.

I(A): means coupling suitable power for energizing said thermostat from said space conditioning equipment to said thermostat;— For instance, the '825 Accused Product draws power (power for energizing) from HVAC transformer (said space conditioning equipment).

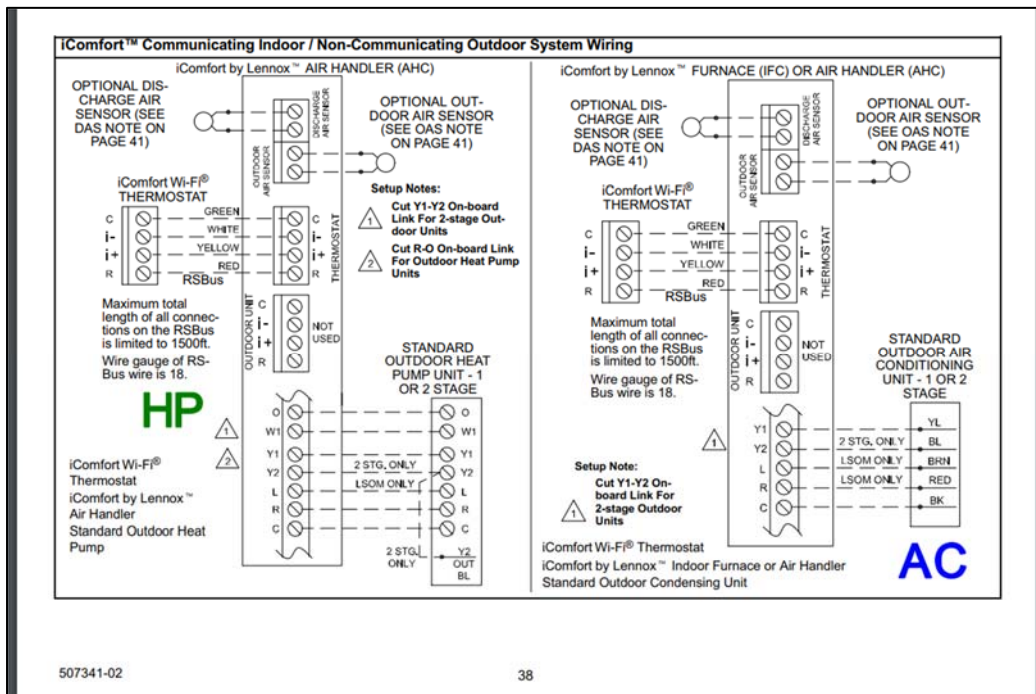
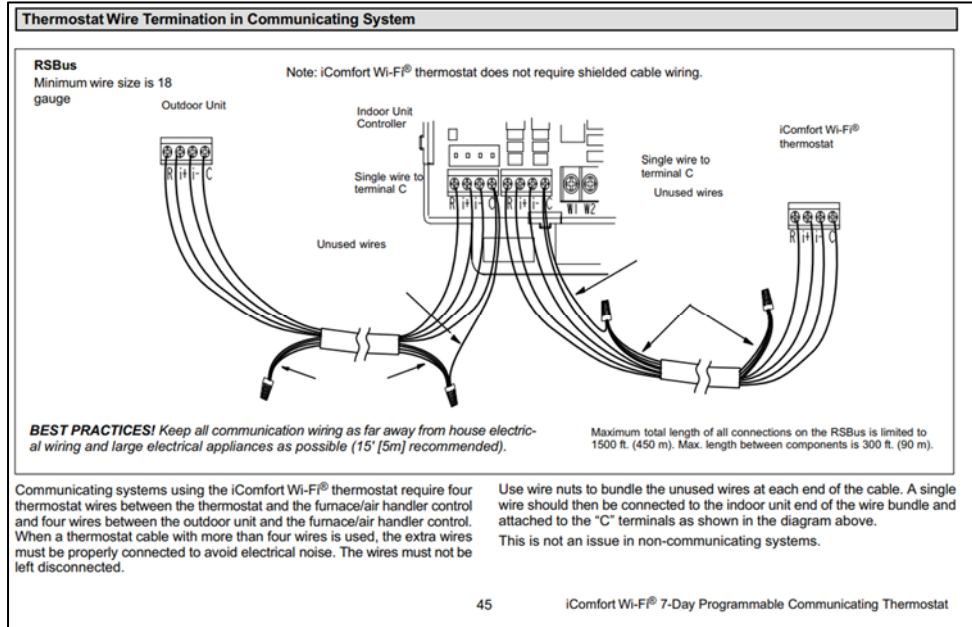

I(B): an interactive interface for a user to enter programming information into said thermostat; - For instance, the '825 Accused Products include an LCD touchscreen display. The touchscreen enables a user to configure settings such as set schedules, priorities etc. (to enter programming information).



Alerts and Reminders: Not only will your iComfort Wi-Fi monitor itself with advanced diagnostics, but it can also send you and your dealer alerts and emails if the system needs service or maintenance.

Smart Energy Use: Seasonal schedules save energy all year long, while One-Touch Away Mode helps your system use less when no one is home.

App-Enabled: Free to download for Apple and Android devices, the iComfort App is like a touchscreen window into your home comfort. Whether you're on the road or on the couch, simply start the app to check and change your temperature with only a finger.

Convenience

Touchscreen Operation: The bright, clear screen is easy to read in any light, and easy to operate with just one finger.

One-Touch Away Mode: One touch or remote click will put your system into One-Touch Away Mode, reducing system use and energy consumption when no one is home.

Weather Data: The iComfort Wi-Fi can display live weather alerts and a five-day forecast, so you're always prepared for what's happening outside.

Screen Saver: Customize your thermostat by uploading a family picture.

Remote Access: Once connected to the Cloud through your wireless network, your iComfort Wi-Fi can be adjusted from anywhere in the world via your smartphone, tablet, laptop or other web-enabled device.

Comfort

Perfect Air: The iComfort Wi-Fi works with your Lennox® system to carefully control both temperature and humidity, filling your home with perfectly comfortable air.

Peace of Mind: Like all Lennox equipment, the iComfort Wi-Fi is built to deliver more, and built to last. So you'll enjoy reliable comfort season after season.

Precise Control: For the ultimate in home comfort, pair the iComfort Wi-Fi thermostat with iHarmony Zoning to customize the temperature in any area of your home. Zoning not only helps eliminate hot and cold spots, but also helps you save money on utility bills by ensuring that you are not heating or cooling seldom-used areas of your home, like guest rooms or media rooms.

User Features and Help (?) Screens

From the Home screen, touch the (?) button to access the Features screen. The Features screen (figure 3) allows you access to edit programs, system settings, display settings, zoning settings, alerts, reminders, service and help (?).

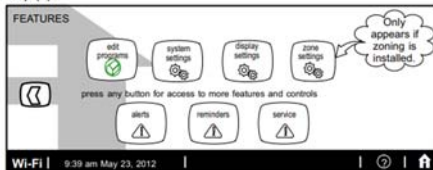

Figure 3. Features Screen - Indoor Settings

EDIT PROGRAMS (SCHEDULE)

Touch **edit programs** button (see fig. 3). Figure 4 shows the EDIT PROGRAMS screen.

Edit the "season programs" to reflect your preferences. (The **Save energy** program uses high-efficiency Energy Star settings to promote energy conservation.)

- **select programs** - Select a preset program; or touch and hold any button to enable the keyboard to change program names to suit your preferences.
- **select days** - Select week/weekend, individual days, all 7 days.
- **time** - Use up/down arrows to change time in 15 minute increments.
- **cool- and heat-to** - Use up/down arrows to change temperature in 1 degree increments.
- **fan mode** - Select on, auto, or circulate.

In the example in Figure 4, the evening time has been disabled by touching and holding the time button for that time period un time is replaced with **add setting**. To re-enable, touch **add setting** that time period. Use the **restore** button to restore defaults for the preset programs. If no additional adjustment are made to any programs, touch "X" button to exit. If changes are made to any programs then touch the **save** button and then touch X to exit this screen and return to the FEATURES screen.

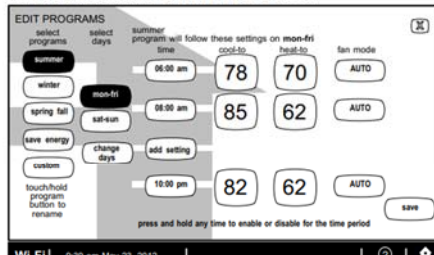

Figure 4. EDIT PROGRAMS Screen

TURN PROGRAMMING ON

If the programming is OFF, touch the system mode button (shown in figure 5, labeled **heat or cool**) to open the manual settings menu. **Programs** is the final selection in this menu. Select **programs** to display the program settings menu. (The menu will disappear if you don't make a selection within a few seconds). Select an option (e.g. **spring/fall**). The system mode button will display the selected program (e.g. **spring...program is ON**).

Touchscreen

Features a large, easy-to-use display with adjustable brightness



I(C): a temperature sensor for providing an electrical signal indicative of the temperature of a conditioned space in which the temperature sensor is situated;-For instance, the '825 Accused Products works with temperature sensors. The temperature sensor detects the

current space temperature and enables a user to see the current indoor temperature.

29	Critical	(Thermostat) The thermostat is reading an indoor temperature that is higher than 99°F. The thermostat will not allow any heating operation to begin until it senses a temperature lower than 99°F.	Indoor temperature rose above 99°F during a heating or cooling demand. Heating operation is not allowed. Check to ensure that Heating Equipment is not stuck ON (reversing valve, etc.). Check the accuracy of the thermostat temperature sensor. Select cooling system mode to cool the indoor space.
30	Moderate	(Thermostat) The thermostat is reading an indoor temperature that is lower than 40°F. The thermostat will not allow any cooling operation to begin until it senses a temperature higher than 40°F.	Indoor Temp fell below 40°F. Cooling operation is not allowed. Check to ensure that cooling equipment is not stuck ON. Check accuracy of the thermostat temperature sensor. Select heating system mode to heat the indoor space to above 40°F.

I(D): a processor, said processor including;-For instance, the '825 Accused Products includes a processor.

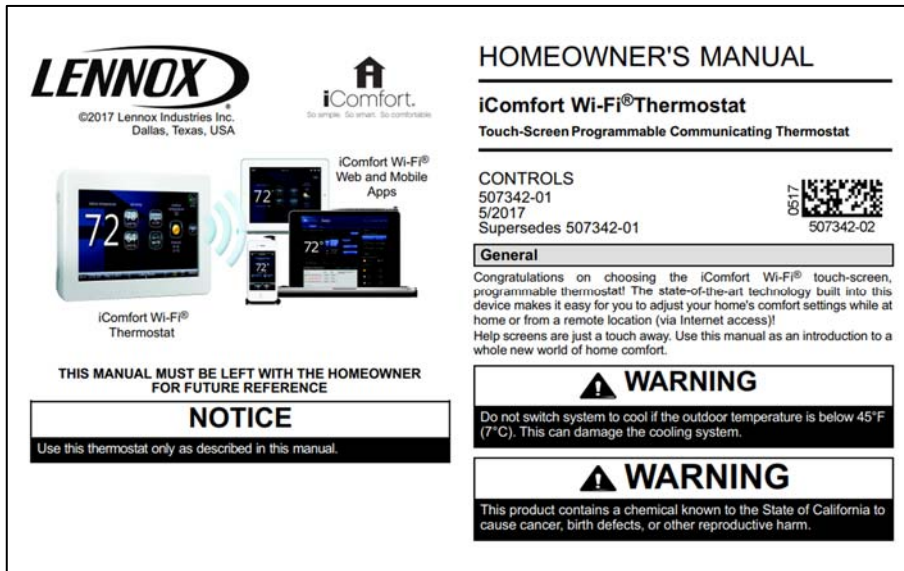

I(D)(1): a central processing unit;-For instance, in the '825 Accused Products the processor, includes a central processing unit.

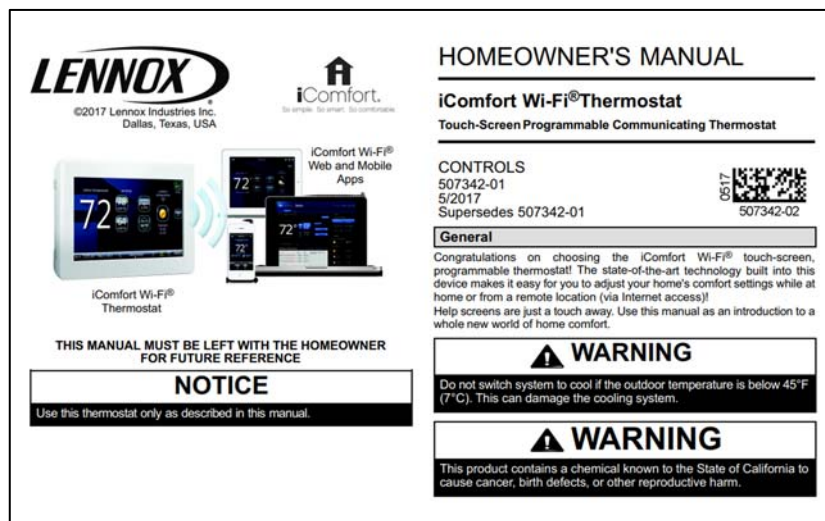

1(D)(2): a first memory coupled to said central processing unit for storing program and data information; and;-For instance, in the '825 Accused Products the application processor includes internal memory.

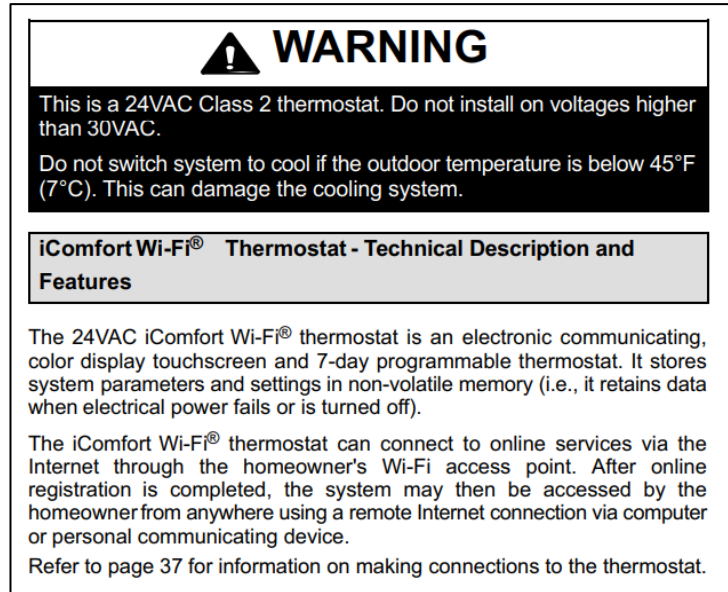

1(D)(3): an input/output unit including: - For instance, the '825 Accused Products includes input/output. Said I/O receives and sends data between the variety of thermostat sensors, LCD screen, and the space conditioning equipment.

This thermostat supports:

- Wireless bands 802.11b, 802.11g and 802.11n
- Three languages (English, French, Spanish)
- Air conditioning or heat pump units with up to four stages of heat / two stages of compressor operation (2 stages of heat pump heating, 2 stages of auxiliary back-up heating and 2 stages of emergency heating)
- Variable-capacity / multiple-stage heat / cool and universal compatibility (gas/electric/heat pump/air conditioner).
- Dual-fuel capable (iComfort®-enabled HP only) with two balance points.
- Indoor air quality with time-based notification of consumables including media filters, UVC bulbs, humidifier pads and PureAir™ system catalyst service / replacement,
- iHarmony® Zoning System (2 - 4 zones)
- Lennox iComfort® Equipment Interface Module (Catalog number 10T50) (provides iComfort Wi-Fi® to non-communicating indoor unit,
- Humidification measurement and control.
- Dew point adjustment control
- Humiditrol® Enhanced Dehumidification Accessory (EDA)
- Multiple-stage HVAC systems
- Equipment maintenance reminders
- Autochangeover mode -- Permits control of heating, cooling, humidification, and dehumidification without user involvement
- All Lennox branded communicating outdoor units contain a built-in outdoor temperature sensor.

Figure 13. Registration Screen

NOTE - This following information is customer setup instructions and is shown here to allow the installer to help walk the customer through the setup process.

After registering through your iComfortWi-Fi® thermostat interface, go to the homeowner's computer and locate the email sent from the server.

NOTE - If the customer has already setup an account, click the "Click Here" button to access that account.

Click on the Register link; the screen (to the left) will appear. Fill in the User Name and Password fields and check the agree to terms and conditions box. Click **Create User** button.

Adding Non-Communicating Outdoor Unit and Accessories

OUTDOOR UNIT (AIR CONDITIONER OR HEAT PUMP)

To add (or remove) an outdoor unit that is not iComfort®-enabled, you must be at the "Add or Remove Non-communicating equipment?" screen.

1. Touch the **yes** button next to **Add or Remove Non-communicating equipment?**
2. In the "non-communicating device list" screen, use the arrows to highlight **Outdoor Unit Type** and touch **edit**.
3. Touch one of the radio buttons to select a 1-or 2-stage air conditioner unit or a 1-or 2-stage heat pump unit; touch **save**.
4. Use arrows to highlight any red colored text in the device list (e.g. select **Outdoor Unit Capacity**; text turns white). Touch **edit**.

507341-02 12

5. Use either the up or down arrows to display the correct size outdoor unit. Touch **save** to continue.

NOTE - If the defaults are correct, you do not have to make any changes, but you must touch save. When all red text is gone, the back button will appear; touch it to return to the "Add or Remove Non-communicating equipment?" screen.

ADDING A HUMIDIFIER

Before adding a humidifier, be sure that the:

- Humidifier is wired to the furnace or air handler control as shown on the Optional Accessories wiring diagram (see page 42).
- Entire system is wired, powered up, and the thermostat has detected the system's installed communicating devices, and you are at the "Add or Remove Non-communicating equipment?" screen.

To add (or remove) a humidifier:

1. Touch the **yes** button on this screen.
2. In the "non-communicating device list" screen, use the arrows to highlight **Humidifier** (note the current value, **Not Installed**) and touch **edit**.
3. Touch one of the radio buttons to select the type of humidifier (or select **Not Installed**, if removing humidifier); touch **save**.
4. The previous screen returns, but the current value now shows your selection. Touch the **back** button.
5. The "Add or Remove..." screen reappears with your addition shown in the system devices list. At this point, you may add more equipment (touch **yes**) or if finished, touch the **next** button to advance to the "Adjust a setting..." screen (see page 15).

NOTE - Adding humidity regulating non-communicating devices may be a 2-step procedure:

- **First** the device must be installed and wired. After the humidifier is installed, the setting under the "System" mode "Humidification Control Mode" defaults to "Basic".
- **Second**, if you want another mode, i.e. Precision, Basic Dew Point, or Precision Dew Point, the device requires further configuration (see page 15).

ADDING HUMIDITROL® OR AN AUXILIARY DEHUMIDIFIER

Before adding a dehumidifier, be sure that:

- the dehumidifier is wired to the furnace or air handler control as shown on the Optional Accessories wiring diagram (see page 42).
- the entire system is wired, powered up, and the thermostat has detected the system's installed communicating devices, and you are at the "Add or Remove Non-communicating equipment?" screen.

To add (or remove) a dehumidifier, you must be at the "Add or Remove Non-communicating equipment?" screen.

1. Touch the **yes** button on this screen.
2. In the "non-communicating device list" screen, use the arrows to highlight **Dehumidifier** and touch **edit**. Note the current value (e.g. Not Installed).
3. Touch one of the radio buttons to select the type of dehumidifier (or select **Not Installed**, if removing dehumidifier); touch **save**.
4. When you scroll to the Dehumidifier device, (Note the current value, e.g. Humiditrol.) Click **back** to return to the "Add or Remove..." screen.
5. The "Add or Remove..." screen reappears with your addition shown in the system devices list. At this point, you may add more equipment (touch **yes**) or if finished, touch the **next** button to advance to the "Adjust a setting..." screen.

NOTE - Adding humidity regulating non-communicating devices may be a 2-step procedure:

- **First** the device must be installed and wired. After the dehumidifier is installed, the setting under the "System" mode "Dehumidification Control Mode" defaults to "Basic".
- **Second**, set Humiditrol® comfort adjust overcooling and the min/max dehumidification setpoints if desired (see page 16).

While iComfort Wi-Fi is designed for use with premium Lennox® equipment, the iComfort Wi-Fi Flex can work with almost any system. So no matter what type of home heating and cooling equipment you have, you can enjoy the innovation of Lennox, and a more comfortable, energy-efficient home.



	iComfort Wi-Fi®	iComfort Wi-Fi® Flex
Compatible with Lennox®-brand communicating heating and cooling equipment	•	
Compatible with Lennox-brand non-communicating equipment and most other brands of heating and cooling equipment		•
Touchscreen Operation	•	•
Remote Access	•	•
7-Day Programmable	•	•
One-Touch Away	•	•
5-Day Weather Forecast	•	•
Customizable Reminders	•	•
Automatic Updates	•	•
Dual-Fuel Compatible	•	•
Humidity Control	•	•
Diagnostics and Alerts	Highly Advanced	Limited Reporting
Compatible with zoned systems	Designed for integration with iHarmony® Zoning System	
Exchanges information with heating and cooling equipment	Uses Lennox Precise Comfort® Technology to optimize system performance	
Warranty	5-Year Limited	5-Year Limited

1(D)(3)(a): a sensor input coupled to said temperature sensor for receiving said electrical signal therefrom; and; - For instance, the '825 Accused Products includes a thermostat sensor which senses the current space temperature (receiving said electrical signal).

29	Critical	(Thermostat) The thermostat is reading an indoor temperature that is higher than 99°F. The thermostat will not allow any heating operation to begin until it senses a temperature lower than 99°F.	Indoor temperature rose above 99°F during a heating or cooling demand. Heating operation is not allowed. Check to ensure that Heating Equipment is not stuck ON (reversing valve, etc.). Check the accuracy of the thermostat temperature sensor. Select cooling system mode to cool the indoor space.
30	Moderate	(Thermostat) The thermostat is reading an indoor temperature that is lower than 40°F. The thermostat will not allow any cooling operation to begin until it senses a temperature higher than 40°F.	Indoor Temp fell below 40°F. Cooling operation is not allowed. Check to ensure that cooling equipment is not stuck ON. Check accuracy of the thermostat temperature sensor. Select heating system mode to heat the indoor space to above 40°F.

1(C)(4)(b): a control output coupled to the space conditioning equipment for issuing control signals thereto; and; - For instance, the '825 Accused Products control the heating and cooling system (space conditioning equipment).

iComfort Wi-Fi® Thermostat

The communicating iComfort Wi-Fi® thermostat is an electronic 7-day programmable touch-screen thermostat with a color display. It also offers enhanced capabilities which include: humidification measurement and control, dew point adjustment control, dehumidification measurement and control, Humiditrol® Enhanced Dehumidification Accessory (EDA) compatibility, and equipment maintenance reminders. The thermostat's autochangeover mode permits control of heating, cooling, humidification, and dehumidification without user involvement.

Figure 13. Registration Screen

NOTE - This following information is customer setup instructions and is shown here to allow the installer to help walk the customer through the setup process.

After registering through your iComfortWi-Fi® thermostat interface, go to the homeowner's computer and locate the email sent from the server.

NOTE - if the customer has already setup an account, click the "Click Here" button to access that account.

Click on the Register link; the screen (to the left) will appear. Fill in the User Name and Password fields and check the agree to terms and conditions box. Click **Create User** button.

507341-02 12

Adding Non-Communicating Outdoor Unit and Accessories

OUTDOOR UNIT (AIR CONDITIONER OR HEAT PUMP)

To add (or remove) an outdoor unit that is not iComfort®-enabled, you must be at the "Add or Remove Non-communicating equipment?" screen.

1. Touch the **yes** button next to **Add or Remove Non-communicating equipment?**
2. In the "non-communicating device list" screen, use the arrows to highlight **Outdoor Unit Type** and touch **edit**.
3. Touch one of the radio buttons to select a 1-or 2-stage air conditioner unit or a 1-or 2-stage heat pump unit; touch **save**.
4. Use arrows to highlight any red colored text in the device list (e.g. select **Outdoor Unit Capacity**; text turns white). Touch **edit**.

5. Use either the up or down arrows to display the correct size outdoor unit. Touch **save** to continue.

NOTE - If the defaults are correct, you do not have to make any changes, but you must touch save. When all red text is gone, the back button will appear; touch it to return to the "Add or Remove Non-communicating equipment?" screen.

ADDING A HUMIDIFIER

Before adding a humidifier, be sure that the:

- Humidifier is wired to the furnace or air handler control as shown on the Optional Accessories wiring diagram (see page 42).
- Entire system is wired, powered up, and the thermostat has detected the system's installed communicating devices, and you are at the "Add or Remove Non-communicating equipment?" screen.

To add (or remove) a humidifier:

1. Touch the **yes** button on this screen.
2. In the "non-communicating device list" screen, use the arrows to highlight **Humidifier** (note the current value, **Not Installed**) and touch **edit**.
3. Touch one of the radio buttons to select the type of humidifier (or select **Not Installed**, if removing humidifier); touch **save**.
4. The previous screen returns, but the current value now shows your selection. Touch the **back** button.
5. The "Add or Remove..." screen reappears with your addition shown in the system devices list. At this point, you may add more equipment (touch **yes**) or if finished, touch the **next** button to advance to the "Adjust a setting..." screen (see page 15).

NOTE - Adding humidity regulating non-communicating devices may be a 2-step procedure:

- **First** the device must be installed and wired. After the humidifier is installed, the setting under the "System" mode "Humidification Control Mode" defaults to "Basic".
- **Second**, if you want another mode, i.e. Precision, Basic Dew Point, or Precision Dew Point, the device requires further configuration (see page 15).

Adding Humiditrol® or an Auxiliary Dehumidifier

Before adding a dehumidifier, be sure that:

- the dehumidifier is wired to the furnace or air handler control as shown on the Optional Accessories wiring diagram (see page 42).
- the entire system is wired, powered up, and the thermostat has detected the system's installed communicating devices, and you are at the "Add or Remove Non-communicating equipment?" screen.

To add (or remove) a dehumidifier, you must be at the "Add or Remove Non-communicating equipment?" screen.

1. Touch the **yes** button on this screen.
2. In the "non-communicating device list" screen, use the arrows to highlight **Dehumidifier** and touch **edit**. Note the current value (e.g. Not Installed).
3. Touch one of the radio buttons to select the type of dehumidifier (or select **Not Installed**, if removing dehumidifier); touch **save**.
4. When you scroll to the Dehumidifier device, (Note the current value, e.g. Humiditrol.) Click **back** to return to the "Add or Remove..." screen.
5. The "Add or Remove..." screen reappears with your addition shown in the system devices list. At this point, you may add more equipment (touch **yes**) or if finished, touch the **next** button to advance to the "Adjust a setting..." screen.

NOTE - Adding humidity regulating non-communicating devices may be a 2-step procedure:

- **First** the device must be installed and wired. After the dehumidifier is installed, the setting under the "System" mode "Dehumidification Control Mode" defaults to "Basic".
- **Second**, set Humiditrol® comfort adjust overcooling and the min/max dehumidification setpoints if desired (see page 16).

I(D)(4): a real time clock;- For instance, in the '825 Accused Products the processor, includes a real time clock.

Adjusting System Setting

SET TIME AND DATE

Use the arrows to select **Time and Date**; touch **edit** to proceed to the "Set current time and date" screen.

When "Time and Date" screen appears, enter the correct date as follows:

- Use the left and right arrows to change the month and year.
- Touch a day of the month to select it.
- Touch on the hour or minute; up down arrows appear to allow change.
- Touch the **am/pm** field to toggle it between am and pm.
- When the correct date and time is set, touch **save** to save settings and return to previous settings screen.

Touch **next** to continue to next screen.

I(D)(5): a non-volatile random access memory; and; - For instance, in the '825 Accused

Products the processor includes a non-volatile random access memory.

 WARNING
<p>This is a 24VAC Class 2 thermostat. Do not install on voltages higher than 30VAC.</p> <p>Do not switch system to cool if the outdoor temperature is below 45°F (7°C). This can damage the cooling system.</p>
iComfort Wi-Fi® Thermostat - Technical Description and Features
<p>The 24VAC iComfort Wi-Fi® thermostat is an electronic communicating, color display touchscreen and 7-day programmable thermostat. It stores system parameters and settings in non-volatile memory (i.e., it retains data when electrical power fails or is turned off).</p> <p>The iComfort Wi-Fi® thermostat can connect to online services via the Internet through the homeowner's Wi-Fi access point. After online registration is completed, the system may then be accessed by the homeowner from anywhere using a remote Internet connection via computer or personal communicating device.</p> <p>Refer to page 37 for information on making connections to the thermostat.</p>

1(D)(6): a control program stored in said first memory; - For instance, the memory of '825 Accused Products stores all the settings and other information in the memory.

 WARNING
<p>This is a 24VAC Class 2 thermostat. Do not install on voltages higher than 30VAC.</p> <p>Do not switch system to cool if the outdoor temperature is below 45°F (7°C). This can damage the cooling system.</p>
iComfort Wi-Fi® Thermostat - Technical Description and Features
<p>The 24VAC iComfort Wi-Fi® thermostat is an electronic communicating, color display touchscreen and 7-day programmable thermostat. It stores system parameters and settings in non-volatile memory (i.e., it retains data when electrical power fails or is turned off).</p> <p>The iComfort Wi-Fi® thermostat can connect to online services via the Internet through the homeowner's Wi-Fi access point. After online registration is completed, the system may then be accessed by the homeowner from anywhere using a remote Internet connection via computer or personal communicating device.</p> <p>Refer to page 37 for information on making connections to the thermostat.</p>

User Features and Help (?) Screens

From the Home screen, touch the (?) button to access the Features screen. The Features screen (figure 3) allows you access to edit programs, system settings, display settings, zoning settings, alerts, reminders, service and help (?).

Figure 3. Features Screen - Indoor Settings

EDIT PROGRAMS (SCHEDULE)
Touch **edit programs** button (see fig. 3). Figure 4 shows the EDIT PROGRAMS screen.

Edit the "season programs" to reflect your preferences. (The **Save energy** program uses high-efficiency Energy Star settings to promote energy conservation.)

- **select programs** - Select a preset program; or touch and hold any button to enable the keyboard to change program names to suit your preferences.
- **select days** - Select week/weekend, individual days, all 7 days.
- **time** - Use up/down arrows to change time in 15 minute increments.
- **cool-** and **heat-to** - Use up/down arrows to change temperature in 1 degree increments.
- **fan mode** - Select on, auto, or circulate.

Figure 4. EDIT PROGRAMS Screen

TURN PROGRAMMING ON
If the programming is OFF, touch the system mode button (shown in figure 5, labeled **heat or cool**) to open the manual settings menu. **Programs** is the final selection in this menu. Select **programs** to display the program settings menu. (The menu will disappear if you don't make a selection within a few seconds). Select an option (e.g. **spring/fall**). The system mode button will display the selected program (e.g. **spring...program is ON**).

Adjusting System Setting

SET TIME AND DATE

Use the arrows to select **Time and Date**; touch **edit** to proceed to the "Set current time and date" screen.

When "Time and Date" screen appears, enter the correct date as follows:

- Use the left and right arrows to change the month and year.
- Touch a day of the month to select it.
- Touch on the hour or minute; up down arrows appear to allow change.
- Touch the **am/pm** field to toggle it between am and pm.
- When the correct date and time is set, touch **save** to save settings and return to previous settings screen.

Touch **next** to continue to next screen.

I(D)(a): said real time clock to periodically read its current time and date information into said non-volatile memory; and; - For instance, the '825 Accused Products include a real time clock which periodically reads the current time and date into the non volatile memory.

Adjusting System Setting

SET TIME AND DATE

Use the arrows to select **Time and Date**; touch **edit** to proceed to the "Set current time and date" screen.

When "Time and Date" screen appears, enter the correct date as follows:

- Use the left and right arrows to change the month and year.
- Touch a day of the month to select it.
- Touch on the hour or minute; up down arrows appear to allow change.
- Touch the **am/pm** field to toggle it between am and pm.
- When the correct date and time is set, touch **save** to save settings and return to previous settings screen.

Touch **next** to continue to next screen.



WARNING

This is a 24VAC Class 2 thermostat. Do not install on voltages higher than 30VAC.

Do not switch system to cool if the outdoor temperature is below 45°F (7°C). This can damage the cooling system.

iComfort Wi-Fi® Thermostat - Technical Description and Features

The 24VAC iComfort Wi-Fi® thermostat is an electronic communicating, color display touchscreen and 7-day programmable thermostat. It stores system parameters and settings in non-volatile memory (i.e., it retains data when electrical power fails or is turned off).

The iComfort Wi-Fi® thermostat can connect to online services via the Internet through the homeowner's Wi-Fi access point. After online registration is completed, the system may then be accessed by the homeowner from anywhere using a remote Internet connection via computer or personal communicating device.

Refer to page 37 for information on making connections to the thermostat.

I(D)(b): upon restart after a loss and then return of power from said space conditioning equipment, read the time and date information stored in said non-volatile memory into said real time clock.; - For instance, the '825 Accused Products upon restart after a loss and subsequent return of power will read the time and date from the non volatile memory.

Adjusting System Setting

SET TIME AND DATE

Use the arrows to select **Time and Date**; touch **edit** to proceed to the "Set current time and date" screen.

When "Time and Date" screen appears, enter the correct date as follows:

- Use the left and right arrows to change the month and year.
- Touch a day of the month to select it.
- Touch on the hour or minute; up down arrows appear to allow change.
- Touch the **am/pm** field to toggle it between am and pm.
- When the correct date and time is set, touch **save** to save settings and return to previous settings screen.

Touch **next** to continue to next screen.

 **WARNING**

This is a 24VAC Class 2 thermostat. Do not install on voltages higher than 30VAC.

Do not switch system to cool if the outdoor temperature is below 45°F (7°C). This can damage the cooling system.

iComfort Wi-Fi® Thermostat - Technical Description and Features

The 24VAC iComfort Wi-Fi® thermostat is an electronic communicating, color display touchscreen and 7-day programmable thermostat. It stores system parameters and settings in non-volatile memory (i.e., it retains data when electrical power fails or is turned off).

The iComfort Wi-Fi® thermostat can connect to online services via the Internet through the homeowner's Wi-Fi access point. After online registration is completed, the system may then be accessed by the homeowner from anywhere using a remote Internet connection via computer or personal communicating device.

Refer to page 37 for information on making connections to the thermostat.

103. At least as early as of the date of the filing of the Complaint, Defendant has had actual knowledge of the '825 Patent.

104. Additionally, Defendant contributorily infringes at least one or more claims of the '825 Patent by providing the '825 Accused Products and/or software components thereof, that embody a material part of the claimed inventions of the '825 Patent, that are known by Defendant to be specially made or adapted for use in an infringing manner, and are not staple articles with substantial non-infringing uses. The '825 Accused Products are specially designed

to infringe at least one or more claims of the '825 Patent, and their accused components have no substantial non-infringing uses. In particular, on information and belief, the software modules and code that implement and perform the infringing functionalities identified above are specially made and adapted to carry out said functionality and do not have any substantial non-infringing uses.

105. At least as early as the filing and/or service of this Complaint, Defendant's infringement of the '825 Patent was and continues to be willful and deliberate, entitling Rosen to enhanced damages.

106. Additional allegations regarding Defendant's knowledge of the '825 Patent and willful infringement will likely have evidentiary support after a reasonable opportunity for discovery.

107. Defendant's infringement of the '825 Patent is exceptional and entitles Rosen to attorneys' fees and costs incurred in prosecuting this action under 35 U.S.C. § 285.

108. Rosen is in compliance with any applicable marking and/or notice provisions of 35 U.S.C. § 287 with respect to the '825 Patent.

109. Rosen is entitled to recover from Defendant all damages that Rosen has sustained as a result of Defendant's infringement of the '825 Patent, including, without limitation, a reasonable royalty.

COUNT VI: INFRINGEMENT OF U.S. PATENT NO. 7,232,075

110. Rosen incorporates by reference and re-alleges paragraphs 1-109 of this Complaint as if fully set forth herein

111. Defendant has infringed and is infringing, either literally or under the doctrine of equivalents, the '075 Patent in violation of 35 U.S.C. § 271 *et seq.*, directly and/or indirectly, by

making, using, offering for sale, or selling in the United States, and/or importing into the United States without authority or license, among other things, the Lennox iComfort Wi-Fi Thermostat, and other substantially similar products (“the ‘075 Accused Product”).

112. As just one non-limiting example, set forth below (with claim language in bold and italics) is exemplary evidence of infringement of Claim 1 of the ‘075 Patent in connection with the Accused Products. This description is based on publicly available information. Rosen reserves the right to modify this description, including, for example, on the basis of information about the Accused Products that it obtains during discovery

1): A thermostat system for controlling space conditioning equipment comprising: - For instance, the ‘075 Accused Product is a thermostat system for controlling space conditioning equipment such as heater, boiler, humidifiers, heating system or cooling system.

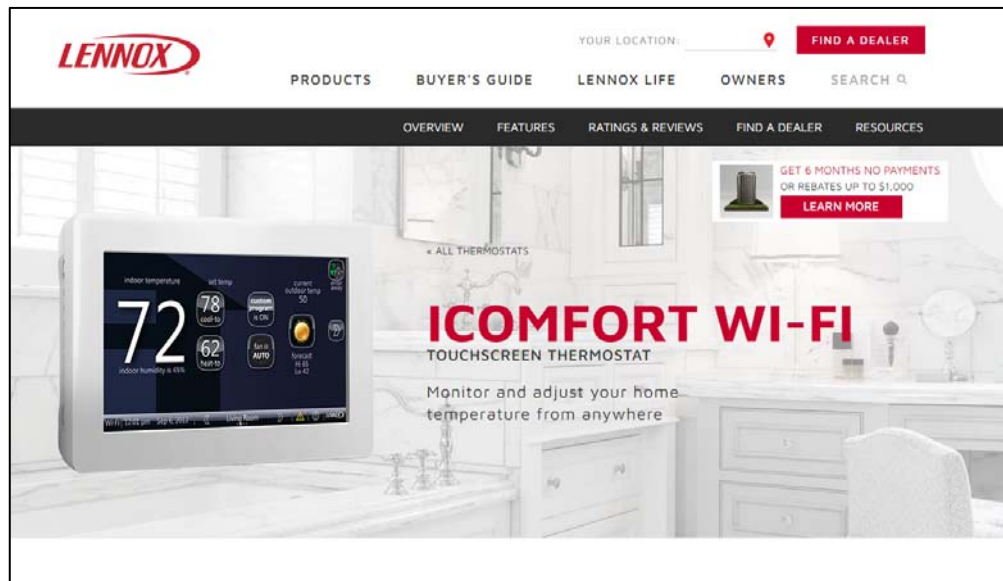

- This thermostat supports:
- Wireless bands 802.11b, 802.11g and 802.11n
 - Three languages (English, French, Spanish)
 - Air conditioning or heat pump units with up to four stages of heat / two stages of compressor operation (2 stages of heat pump heating, 2 stages of auxiliary back-up heating and 2 stages of emergency heating)
 - Variable-capacity / multiple-stage heat / cool and universal compatibility (gas/electric/heat pump/air conditioner).
 - Dual-fuel capable (iComfort®-enabled HP only) with two balance points.
 - Indoor air quality with time-based notification of consumables including media filters, UVC bulbs, humidifier pads and PureAir™ system catalyst service / replacement,
 - iHarmony® Zoning System (2 - 4 zones)
 - Lennox iComfort® Equipment Interface Module (Catalog number 10T50) (provides iComfort Wi-Fi® to non-communicating indoor unit,
 - Humidification measurement and control.
 - Dew point adjustment control
 - Humiditrol® Enhanced Dehumidification Accessory (EDA)
 - Multiple-stage HVAC systems
 - Equipment maintenance reminders
 - Autochangeover mode – Permits control of heating, cooling, humidification, and dehumidification without user involvement
 - All Lennox branded communicating outdoor units contain a built-in outdoor temperature sensor.

1(A) a temperature sensor for providing an electrical signal indicative of the temperature of a conditioned space in which the temperature sensor is situated; - For instance, the '075 Accused Products come with a temperature sensor, which is used to detect the temperature of a room. The sensor senses the temperature and displays it on the thermostat screen. The temperature sensor is situated within the conditioned space.

29	Critical	(Thermostat) The thermostat is reading an indoor temperature that is higher than 99°F. The thermostat will not allow any heating operation to begin until it senses a temperature lower than 99°F.	Indoor temperature rose above 99°F during a heating or cooling demand. Heating operation is not allowed. Check to ensure that Heating Equipment is not stuck ON (reversing valve, etc.). Check the accuracy of the thermostat temperature sensor. Select cooling system mode to cool the indoor space.
30	Moderate	(Thermostat) The thermostat is reading an indoor temperature that is lower than 40°F. The thermostat will not allow any cooling operation to begin until it senses a temperature higher than 40°F.	Indoor Temp fell below 40°F. Cooling operation is not allowed. Check to ensure that cooling equipment is not stuck ON. Check accuracy of the thermostat temperature sensor. Select heating system mode to heat the indoor space to above 40°F.

1(B): a transparent touch pad juxtaposed over a liquid crystal display to constitute a touch screen for interactive interface with a user and for selectively displaying alphanumeric and graphic devices; - For instance, the '075 Accused Products come with an LCD (liquid

crystal display) having a transparent touch pad which is an interactive interface, displaying graphical icons and text to represent temperature, schedule a program or set priority for rooms.



Convenience

Touchscreen Operation: The bright, clear screen is easy to read in any light, and easy to operate with just one finger.

One-Touch Away Mode: One touch or remote click will put your system into One-Touch Away Mode, reducing system use and energy consumption when no one is home.

Weather Data: The iComfort Wi-Fi can display live weather alerts and a five-day forecast, so you're always prepared for what's happening outside.

Screen Saver: Customize your thermostat by uploading a family picture.

Alerts and Reminders: Not only will your iComfort Wi-Fi monitor itself with advanced diagnostics, but it can also send you and your dealer alerts and emails if the system needs service or maintenance.

Remote Access: Once connected to the Cloud through your wireless network, your iComfort Wi-Fi can be adjusted from anywhere in the world via your smartphone, tablet, laptop or other web-enabled device.

Innovation

Smart Energy Use: Seasonal schedules save energy all year long, while One-Touch Away Mode helps your system use less when no one is home.

App-Enabled: Free to download for Apple and Android devices, the iComfort App is like a touchscreen window into your home comfort. Whether you're on the road or on the couch, simply start the app to check and change your temperature with only a finger.

Comfort

Perfect Air: The iComfort Wi-Fi works with your Lennox® system to carefully control both temperature and humidity, filling your home with perfectly comfortable air.

Peace of Mind: Like all Lennox equipment, the iComfort Wi-Fi is built to deliver more, and built to last. So you'll enjoy reliable comfort season after season.

Precise Control: For the ultimate in home comfort, pair the iComfort Wi-Fi thermostat with iHarmony Zoning to customize the temperature in any area of your home. Zoning not only helps eliminate hot and cold spots, but also helps you save money on utility bills by ensuring that you are not heating or cooling seldom-used areas of your home, like guest rooms or media rooms.

User Features and Help (?) Screens

From the Home screen, touch the (?) button to access the Features screen. The Features screen (figure 3) allows you access to edit programs, system settings, display settings, zoning settings, alerts, reminders, service and help (?).



Figure 3. Features Screen - Indoor Settings

EDIT PROGRAMS (SCHEDULE)

Touch **edit programs** button (see fig. 3). Figure 4 shows the EDIT PROGRAMS screen.

Edit the "season programs" to reflect your preferences. (The **Save energy** program uses high-efficiency Energy Star settings to promote energy conservation.)

- select programs** - Select a preset program; or touch and hold any button to enable the keyboard to change program names to suit your preferences.
- select days** - Select week/weekend, individual days, all 7 days.
- time** - Use up/down arrows to change time in 15 minute increments.
- cool- and heat-to** - Use up/down arrows to change temperature in 1 degree increments.
- fan mode** - Select on, auto, or circulate.

In the example in Figure 4, the evening time has been disabled by touching and holding the time button for that time period un time is replaced with **add setting**. To re-enable, touch **add setting** that time period. Use the **restore** button to restore defaults for the preset programs. If no additional adjustment are made to any programs, touch "X" button to exit. If changes are made to any programs then touch the **save** button and then touch X to exit this screen and return to the FEATURES screen.



Figure 4. EDIT PROGRAMS Screen

TURN PROGRAMMING ON

If the programming is OFF, touch the system mode button (shown in figure 5, labeled **heat** or **cool**) to open the manual settings menu. **Programs** is the final selection in this menu. Select **programs** to display the program settings menu. (The menu will disappear if you don't make a selection within a few seconds). Select an option (e.g. **spring/fall**). The system mode button will display the selected program (e.g. **spring...program is ON**).

Touchscreen

Features a large, easy-to-use display with adjustable brightness



I(C): a processor, said processor including;-For instance, the '075 Accused Products

75

include a processor.

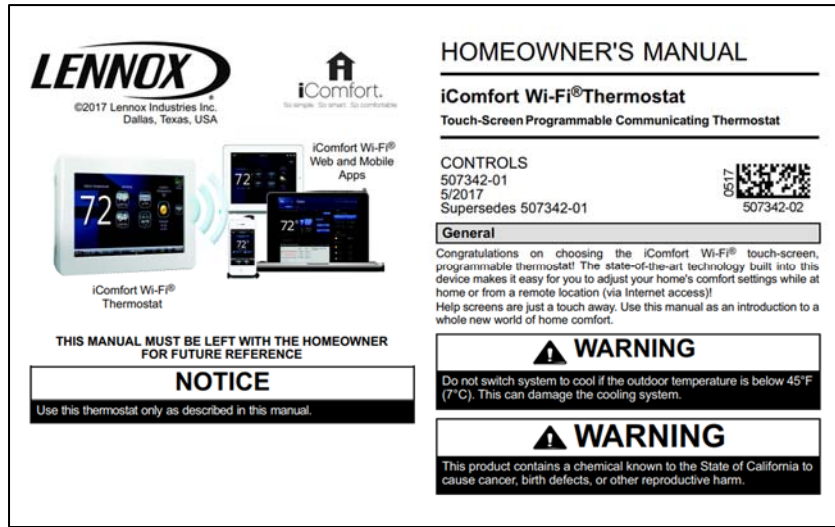

I(C)(1): a central processing unit;—For instance, the ‘075 Accused Products include a central processing unit.

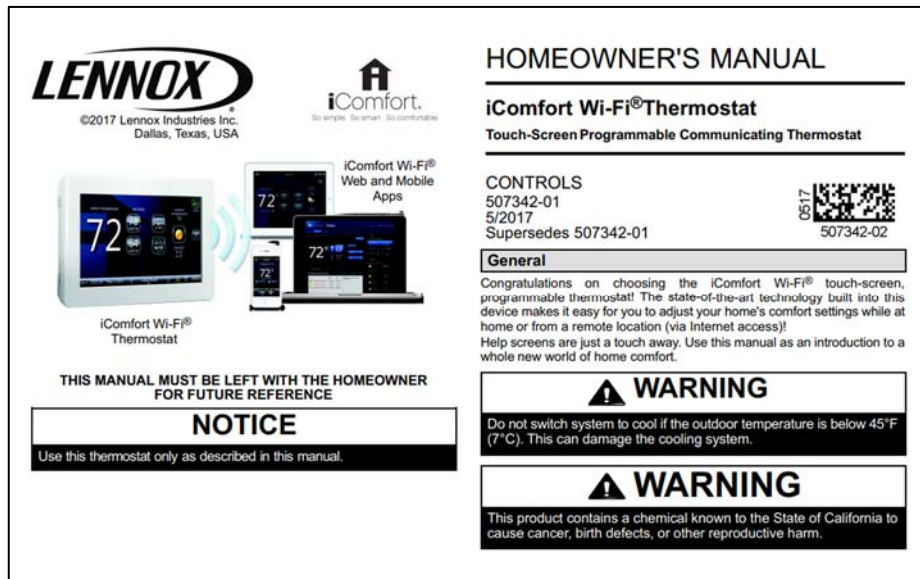

I(C)(2): a real time clock;—For instance, the ‘075 Accused Products include a processor having a real time clock.

Adjusting System Setting

SET TIME AND DATE

Use the arrows to select **Time and Date**; touch **edit** to proceed to the "Set current time and date" screen.

When "Time and Date" screen appears, enter the correct date as follows:

- Use the left and right arrows to change the month and year.
- Touch a day of the month to select it.
- Touch on the hour or minute; up down arrows appear to allow change.
- Touch the **am/pm** field to toggle it between am and pm.
- When the correct date and time is set, touch **save** to save settings and return to previous settings screen.

Touch **next** to continue to next screen.

WARNING

This is a 24VAC Class 2 thermostat. Do not install on voltages higher than 30VAC.

Do not switch system to cool if the outdoor temperature is below 45°F (7°C). This can damage the cooling system.

iComfort Wi-Fi® Thermostat - Technical Description and Features

The 24VAC iComfort Wi-Fi® thermostat is an electronic communicating, color display touchscreen and 7-day programmable thermostat. It stores system parameters and settings in non-volatile memory (i.e., it retains data when electrical power fails or is turned off).

The iComfort Wi-Fi® thermostat can connect to online services via the Internet through the homeowner's Wi-Fi access point. After online registration is completed, the system may then be accessed by the homeowner from anywhere using a remote Internet connection via computer or personal communicating device.

Refer to page 37 for information on making connections to the thermostat.

User Features and Help (?) Screens

From the Home screen, touch the (?) button to access the Features screen. The Features screen (figure 3) allows you access to edit programs, system settings, display settings, zoning settings, alerts, reminders, service and help (?).

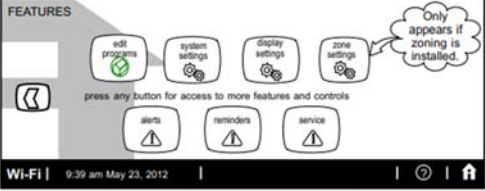

Figure 3. Features Screen - Indoor Settings

EDIT PROGRAMS (SCHEDULE)
Touch **edit programs** button (see fig. 3). Figure 4 shows the EDIT PROGRAMS screen.

Edit the "season programs" to reflect your preferences. (The **Save energy** program uses high-efficiency Energy Star settings to promote energy conservation.)

- **select programs** - Select a preset program; or touch and hold any button to enable the keyboard to change program names to suit your preferences.
- **select days** - Select week/weekend, individual days, all 7 days.
- **time** - Use up/down arrows to change time in 15 minute increments.
- **cool-** and **heat-to** - Use up/down arrows to change temperature in 1 degree increments.
- **fan mode** - Select on, auto, or circulate.

In the example in Figure 4, the evening time has been disabled by touching and holding the time button for that time period on time is replaced with **add setting**. To re-enable, touch **add setting** that time period. Use the **restore** button to restore defaults for the preset programs. If no additional adjustment are made to any programs, touch "X" button to exit. If changes are made to any programs then touch the **save** button and then touch X to exit this screen and return to the FEATURES screen.

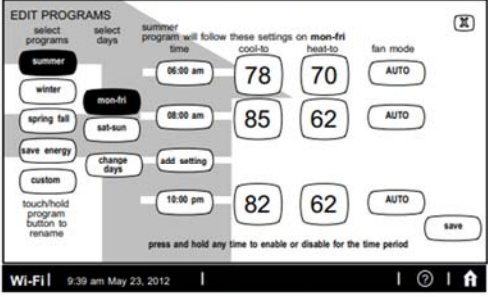

Figure 4. EDIT PROGRAMS Screen

TURN PROGRAMMING ON
If the programming is OFF, touch the system mode button (shown in figure 5, labeled **heat or cool**) to open the manual settings menu. **Programs** is the final selection in this menu. Select **programs** to display the program settings menu. (The menu will disappear if you don't make a selection within a few seconds). Select an option (e.g. **spring/fall**). The system mode button will display the selected program (e.g. **spring...program is ON**).

I(C)(3): a memory coupled to said central processing unit for storing program and data information; and;— For instance, the ‘075 Accused Products include a memory coupled to the CPU.

WARNING

This is a 24VAC Class 2 thermostat. Do not install on voltages higher than 30VAC.

Do not switch system to cool if the outdoor temperature is below 45°F (7°C). This can damage the cooling system.

iComfort Wi-Fi® Thermostat - Technical Description and Features

The 24VAC iComfort Wi-Fi® thermostat is an electronic communicating, color display touchscreen and 7-day programmable thermostat. It stores system parameters and settings in non-volatile memory (i.e., it retains data when electrical power fails or is turned off).

The iComfort Wi-Fi® thermostat can connect to online services via the Internet through the homeowner's Wi-Fi access point. After online registration is completed, the system may then be accessed by the homeowner from anywhere using a remote Internet connection via computer or personal communicating device.

Refer to page 37 for information on making connections to the thermostat.

I(C)(4): an input/output unit including - For instance, the ‘075 Accused Products include a processor in the thermostat having I/O modules. The I/O modules are coupled with the

processor.

This thermostat supports:

- Wireless bands 802.11b, 802.11g and 802.11n
- Three languages (English, French, Spanish)
- Air conditioning or heat pump units with up to four stages of heat / two stages of compressor operation (2 stages of heat pump heating, 2 stages of auxiliary back-up heating and 2 stages of emergency heating)
- Variable-capacity / multiple-stage heat / cool and universal compatibility (gas/electric/heat pump/air conditioner).
- Dual-fuel capable (iComfort®-enabled HP only) with two balance points.
- Indoor air quality with time-based notification of consumables including media filters, UVC bulbs, humidifier pads and PureAir™ system catalyst service / replacement,
- iHarmony® Zoning System (2 - 4 zones)
- Lennox iComfort® Equipment Interface Module (Catalog number 10T50) (provides iComfort Wi-Fi® to non-communicating indoor unit,
- Humidification measurement and control.
- Dew point adjustment control
- Humiditrol® Enhanced Dehumidification Accessory (EDA)
- Multiple-stage HVAC systems
- Equipment maintenance reminders
- Autochangeover mode -- Permits control of heating, cooling, humidification, and dehumidification without user involvement
- All Lennox branded communicating outdoor units contain a built-in outdoor temperature sensor.

<p style="text-align: center;">Figure 13. Registration Screen</p> <p>NOTE - This following information is customer setup instructions and is shown here to allow the installer to help walk the customer through the setup process.</p> <p>After registering through your iComfort Wi-Fi® thermostat interface, go to the homeowner's computer and locate the email sent from the server.</p> <p>NOTE - if the customer has already setup an account, click the "Click Here" button to access that account.</p> <p>Click on the Register link; the screen (to the left) will appear. Fill in the User Name and Password fields and check the agree to terms and conditions box. Click Create User button.</p> <p>507341-02</p>	<p style="text-align: center;">Adding Non-Communicating Outdoor Unit and Accessories</p> <p>OUTDOOR UNIT (AIR CONDITIONER OR HEAT PUMP)</p> <p>To add (or remove) an outdoor unit that is not iComfort®-enabled, you must be at the "Add or Remove Non-communicating equipment?" screen.</p> <ol style="list-style-type: none"> 1. Touch the yes button next to Add or Remove Non-communicating equipment? 2. In the "non-communicating device list" screen, use the arrows to highlight Outdoor Unit Type and touch edit. 3. Touch one of the radio buttons to select a 1-or 2-stage air conditioner unit or a 1-or 2-stage heat pump unit; touch save. 4. Use arrows to highlight any red colored text in the device list (e.g. select Outdoor Unit Capacity; text turns white). Touch edit. <p style="text-align: center;">12</p>
<p>5. Use either the up or down arrows to display the correct size outdoor unit. Touch save to continue.</p> <p>NOTE - If the defaults are correct, you do not have to make any changes, but you must touch save. When all red text is gone, the back button will appear; touch it to return to the "Add or Remove Non-communicating equipment?" screen.</p> <p>ADDING A HUMIDIFIER</p> <p>Before adding a humidifier, be sure that the:</p> <ul style="list-style-type: none"> • Humidifier is wired to the furnace or air handler control as shown on the Optional Accessories wiring diagram (see page 42). • Entire system is wired, powered up, and the thermostat has detected the system's installed communicating devices, and you are at the "Add or Remove Non-communicating equipment?" screen. <p>To add (or remove) a humidifier:</p> <ol style="list-style-type: none"> 1. Touch the yes button on this screen. 2. In the "non-communicating device list" screen, use the arrows to highlight Humidifier (note the current value, Not Installed) and touch edit. 3. Touch one of the radio buttons to select the type of humidifier (or select Not Installed, if removing humidifier); touch save. 4. The previous screen returns, but the current value now shows your selection. Touch the back button. 5. The "Add or Remove..." screen reappears with your addition shown in the system devices list. At this point, you may add more equipment (touch yes) or if finished, touch the next button to advance to the "Adjust a setting..." screen (see page 15). <p>NOTE - Adding humidity regulating non-communicating devices may be a 2-step procedure:</p> <ul style="list-style-type: none"> • First the device must be installed and wired. After the humidifier is installed, the setting under the "System" mode "Humidification Control Mode" defaults to "Basic". 	<ul style="list-style-type: none"> • Second, if you want another mode, i.e. Precision, Basic Dew Point, or Precision Dew Point, the device requires further configuration (see page 15). <p>ADDING HUMIDITROL® OR AN AUXILIARY DEHUMIDIFIER</p> <p>Before adding a dehumidifier, be sure that:</p> <ul style="list-style-type: none"> • the dehumidifier is wired to the furnace or air handler control as shown on the Optional Accessories wiring diagram (see page 42), • the entire system is wired, powered up, and the thermostat has detected the system's installed communicating devices, and you are at the "Add or Remove Non-communicating equipment?" screen. <p>To add (or remove) a dehumidifier, you must be at the "Add or Remove Non-communicating equipment?" screen.</p> <ol style="list-style-type: none"> 1. Touch the yes button on this screen. 2. In the "non-communicating device list" screen, use the arrows to highlight Dehumidifier and touch edit. Note the current value (e.g. Not Installed). 3. Touch one of the radio buttons to select the type of dehumidifier (or select Not Installed, if removing dehumidifier); touch save. 4. When you scroll to the Dehumidifier device, (Note the current value, e.g. Humiditrol.) Click back to return to the "Add or Remove..." screen. 5. The "Add or Remove..." screen reappears with your addition shown in the system devices list. At this point, you may add more equipment (touch yes) or if finished, touch the next button to advance to the "Adjust a setting..." screen. <p>NOTE - Adding humidity regulating non-communicating devices may be a 2-step procedure:</p> <ul style="list-style-type: none"> • First the device must be installed and wired. After the dehumidifier is installed, the setting under the "System" mode "Dehumidification Control Mode" defaults to "Basic". • Second, set Humiditrol® comfort adjust overcooling and the min/max dehumidification setpoints if desired (see page 16).

While iComfort Wi-Fi is designed for use with premium Lennox® equipment, the iComfort Wi-Fi Flex can work with almost any system. So no matter what type of home heating and cooling equipment you have, you can enjoy the innovation of Lennox, and a more comfortable, energy-efficient home.



	iComfort Wi-Fi®	iComfort Wi-Fi® Flex
Compatible with Lennox®-brand communicating heating and cooling equipment	•	
Compatible with Lennox-brand non-communicating equipment and most other brands of heating and cooling equipment		•
Touchscreen Operation	•	•
Remote Access	•	•
7-Day Programmable	•	•
One-Touch Away	•	•
5-Day Weather Forecast	•	•
Customizable Reminders	•	•
Automatic Updates	•	•
Dual-Fuel Compatible	•	•
Humidity Control	•	•
Diagnostics and Alerts	Highly Advanced	Limited Reporting
Compatible with zoned systems	Designed for integration with iHarmony® Zoning System	
Exchanges information with heating and cooling equipment	Uses Lennox Precise Comfort® Technology to optimize system performance	
Warranty	5-Year Limited	5-Year Limited

1(C)(4)(a): a sensor input coupled to said temperature sensor for receiving said electrical signal therefrom- For instance, the '075 Accused Products include sensor inputs that receive a signal indicative of the temperature to the processor of thermostat.

29	Critical	(Thermostat) The thermostat is reading an indoor temperature that is higher than 99°F. The thermostat will not allow any heating operation to begin until it senses a temperature lower than 99°F.	Indoor temperature rose above 99°F during a heating or cooling demand. Heating operation is not allowed. Check to ensure that Heating Equipment is not stuck ON (reversing valve, etc.). Check the accuracy of the thermostat temperature sensor. Select cooling system mode to cool the indoor space.
30	Moderate	(Thermostat) The thermostat is reading an indoor temperature that is lower than 40°F. The thermostat will not allow any cooling operation to begin until it senses a temperature higher than 40°F.	Indoor Temp fell below 40°F. Cooling operation is not allowed. Check to ensure that cooling equipment is not stuck ON. Check accuracy of the thermostat temperature sensor . Select heating system mode to heat the indoor space to above 40°F.

1(C)(4)(b): a control output coupled to the space conditioning equipment for issuing control signals thereto; and- For instance, the '075 Accused Products connect to the heating or cooling systems based on heating or cooling signals generating from the output present in the thermostat.

iComfort Wi-Fi® Thermostat

The communicating iComfort Wi-Fi® thermostat is an electronic 7-day programmable touch-screen thermostat with a color display. It also offers enhanced capabilities which include: humidification measurement and control, dew point adjustment control, dehumidification measurement and control, Humiditrol® Enhanced Dehumidification Accessory (EDA) compatibility, and equipment maintenance reminders. The thermostat's autochangeover mode permits control of heating, cooling, humidification, and dehumidification without user involvement.

Figure 13. Registration Screen

NOTE - This following information is customer setup instructions and is shown here to allow the installer to help walk the customer through the setup process.

After registering through your iComfort Wi-Fi® thermostat interface, go to the homeowner's computer and locate the email sent from the server.

NOTE - if the customer has already setup an account, click the "Click Here" button to access that account.

Click on the Register link; the screen (to the left) will appear. Fill in the User Name and Password fields and check the agree to terms and conditions box. Click **Create User** button.

507341-02

12

Adding Non-Communicating Outdoor Unit and Accessories

OUTDOOR UNIT (AIR CONDITIONER OR HEAT PUMP)

To add (or remove) an outdoor unit that is not iComfort®-enabled, you must be at the "Add or Remove Non-communicating equipment?" screen.

1. Touch the **yes** button next to **Add or Remove Non-communicating equipment?**
2. In the "non-communicating device list" screen, use the arrows to highlight **Outdoor Unit Type** and touch **edit**.
3. Touch one of the radio buttons to select a 1- or 2-stage air conditioner unit or a 1- or 2-stage heat pump unit; touch **save**.
4. Use arrows to highlight any red colored text in the device list (e.g. select **Outdoor Unit Capacity**; text turns white). Touch **edit**.

5. Use either the up or down arrows to display the correct size outdoor unit. Touch **save** to continue.

NOTE - If the defaults are correct, you do not have to make any changes, but you must touch save. When all red text is gone, the back button will appear; touch it to return to the "Add or Remove Non-communicating equipment?" screen.

ADDING A HUMIDIFIER

Before adding a humidifier, be sure that the:

- Humidifier is wired to the furnace or air handler control as shown on the Optional Accessories wiring diagram (see page 42).
- Entire system is wired, powered up, and the thermostat has detected the system's installed communicating devices, and you are at the "Add or Remove Non-communicating equipment?" screen.

To add (or remove) a humidifier:

1. Touch the **yes** button on this screen.
2. In the "non-communicating device list" screen, use the arrows to highlight **Humidifier** (note the current value, **Not Installed**) and touch **edit**.
3. Touch one of the radio buttons to select the type of humidifier (or select **Not Installed**, if removing humidifier); touch **save**.
4. The previous screen returns, but the current value now shows your selection. Touch the **back** button.
5. The "Add or Remove..." screen reappears with your addition shown in the system devices list. At this point, you may add more equipment (touch **yes**) or if finished, touch the **next** button to advance to the "Adjust a setting..." screen (see page 15).

NOTE - Adding humidity regulating non-communicating devices may be a 2-step procedure:

- **First** the device must be installed and wired. After the humidifier is installed, the setting under the "System" mode "Humidification Control Mode" defaults to "Basic".

- **Second**, if you want another mode, i.e. Precision, Basic Dew Point, or Precision Dew Point, the device requires further configuration (see page 15).

ADDING HUMIDITROL® OR AN AUXILIARY DEHUMIDIFIER

Before adding a dehumidifier, be sure that:

- the dehumidifier is wired to the furnace or air handler control as shown on the Optional Accessories wiring diagram (see page 42).
- the entire system is wired, powered up, and the thermostat has detected the system's installed communicating devices, and you are at the "Add or Remove Non-communicating equipment?" screen.

To add (or remove) a dehumidifier, you must be at the "Add or Remove Non-communicating equipment?" screen.

1. Touch the **yes** button on this screen.
2. In the "non-communicating device list" screen, use the arrows to highlight **Dehumidifier** and touch **edit**. Note the current value (e.g. Not Installed).
3. Touch one of the radio buttons to select the type of dehumidifier (or select **Not Installed**, if removing dehumidifier); touch **save**.
4. When you scroll to the Dehumidifier device, (Note the current value, e.g. Humiditrol.) Click **back** to return to the "Add or Remove..." screen.
5. The "Add or Remove..." screen reappears with your addition shown in the system devices list. At this point, you may add more equipment (touch **yes**) or if finished, touch the **next** button to advance to the "Adjust a setting..." screen.

NOTE - Adding humidity regulating non-communicating devices may be a 2-step procedure:

- **First** the device must be installed and wired. After the dehumidifier is installed, the setting under the "System" mode "Dehumidification Control Mode" defaults to "Basic".
- **Second**, set Humiditrol® comfort adjust overcooling and the min/max dehumidification setpoints if desired (see page 16).

I(C)(4)(c): a communications interface adapted to establish communications between said processor and a first remote correspondent which is a source of functional programming;
and- For instance, the '075 Accused Products include Wi-Fi which connects the thermostat to a

remote correspondent. The remote correspondent which is a source of functional programming can be a fan, humidifiers, or any other space conditioning equipment that is to be controlled.

Figure 13. Registration Screen

NOTE - This following information is customer setup instructions and is shown here to allow the installer to help walk the customer through the setup process.

After registering through your iComfortWi-Fi® thermostat interface, go to the homeowner's computer and locate the email sent from the server.

NOTE - if the customer has already setup an account, click the "Click Here" button to access that account.

Click on the Register link; the screen (to the left) will appear. Fill in the User Name and Password fields and check the agree to terms and conditions box. Click **Create User** button.

507341-02

Adding Non-Communicating Outdoor Unit and Accessories

OUTDOOR UNIT (AIR CONDITIONER OR HEAT PUMP)

To add (or remove) an outdoor unit that is not iComfort®-enabled, you must be at the "Add or Remove Non-communicating equipment?" screen.

1. Touch the **yes** button next to **Add or Remove Non-communicating equipment?**
2. In the "non-communicating device list" screen, use the arrows to highlight **Outdoor Unit Type** and touch **edit**.
3. Touch one of the radio buttons to select a 1-or 2-stage air conditioner unit or a 1-or 2-stage heat pump unit; touch **save**.
4. Use arrows to highlight any red colored text in the device list (e.g. select **Outdoor Unit Capacity**; text turns white). Touch **edit**.

5. Use either the up or down arrows to display the correct size outdoor unit. Touch **save** to continue.

NOTE - If the defaults are correct, you do not have to make any changes, but you must touch save. When all red text is gone, the back button will appear; touch it to return to the "Add or Remove Non-communicating equipment?" screen.

ADDING A HUMIDIFIER

Before adding a humidifier, be sure that the:

- Humidifier is wired to the furnace or air handler control as shown on the Optional Accessories wiring diagram (see page 42),
- Entire system is wired, powered up, and the thermostat has detected the system's installed communicating devices, and you are at the "Add or Remove Non-communicating equipment?" screen.

To add (or remove) a humidifier:

1. Touch the **yes** button on this screen.
2. In the "non-communicating device list" screen, use the arrows to highlight **Humidifier** (note the current value, **Not Installed**) and touch **edit**.
3. Touch one of the radio buttons to select the type of humidifier (or select **Not Installed**, if removing humidifier); touch **save**.
4. The previous screen returns, but the current value now shows your selection. Touch the **back** button.
5. The "Add or Remove..." screen reappears with your addition shown in the system devices list. At this point, you may add more equipment (touch **yes**) or if finished, touch the **next** button to advance to the "Adjust a setting..." screen (see page 15).

NOTE - Adding humidity regulating non-communicating devices may be a 2-step procedure:

- **First** the device must be installed and wired. After the humidifier is installed, the setting under the "System" mode "Humidification Control Mode" defaults to "Basic".

- **Second**, if you want another mode, i.e. Precision, Basic Dew Point, or Precision Dew Point, the device requires further configuration (see page 15).

ADDING HUMIDITROL® OR AN AUXILIARY DEHUMIDIFIER

Before adding a dehumidifier, be sure that:

- the dehumidifier is wired to the furnace or air handler control as shown on the Optional Accessories wiring diagram (see page 42),
- the entire system is wired, powered up, and the thermostat has detected the system's installed communicating devices, and you are at the "Add or Remove Non-communicating equipment?" screen.

To add (or remove) a dehumidifier, you must be at the "Add or Remove Non-communicating equipment?" screen.

1. Touch the **yes** button on this screen.
2. In the "non-communicating device list" screen, use the arrows to highlight **Dehumidifier** and touch **edit**. Note the current value (e.g. Not Installed).
3. Touch one of the radio buttons to select the type of dehumidifier (or select **Not Installed**, if removing dehumidifier); touch **save**.
4. When you scroll to the Dehumidifier device, (Note the current value, e.g. Humiditrol.) Click **back** to return to the "Add or Remove..." screen.
5. The "Add or Remove..." screen reappears with your addition shown in the system devices list. At this point, you may add more equipment (touch **yes**) or if finished, touch the **next** button to advance to the "Adjust a setting..." screen.

NOTE - Adding humidity regulating non-communicating devices may be a 2-step procedure:

- **First** the device must be installed and wired. After the dehumidifier is installed, the setting under the "System" mode "Dehumidification Control Mode" defaults to "Basic".
- **Second**, set Humiditrol® comfort adjust overcooling and the min/max dehumidification setpoints if desired (see page 16).

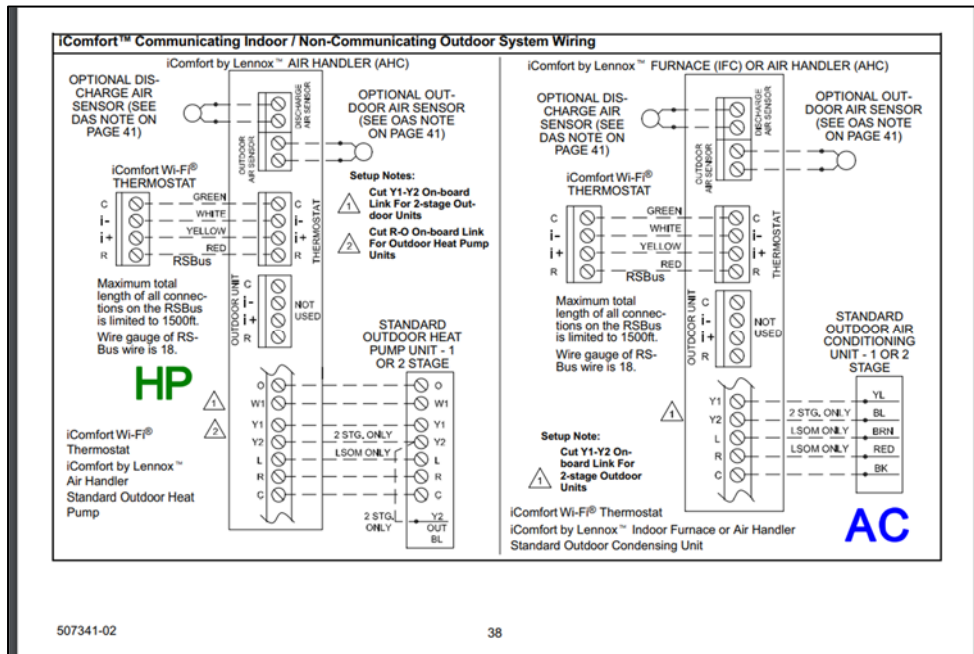
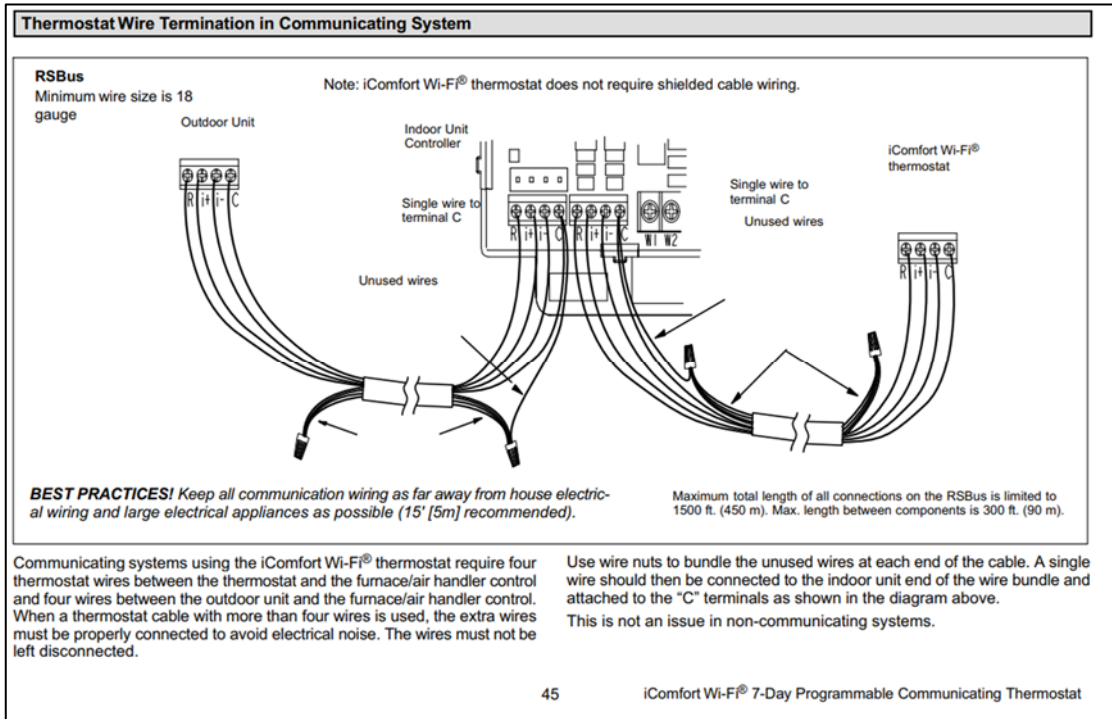

I(D): a control program stored in said memory for causing said central processing unit to selectively:- For instance, the '075 Accused Products have programs stored in memory that cause the CPU to perform certain tasks, such as choosing system modes or scheduling a day.



WARNING

This is a 24VAC Class 2 thermostat. Do not install on voltages higher than 30VAC.

Do not switch system to cool if the outdoor temperature is below 45°F (7°C). This can damage the cooling system.

iComfort Wi-Fi® Thermostat - Technical Description and Features

The 24VAC iComfort Wi-Fi® thermostat is an electronic communicating, color display touchscreen and 7-day programmable thermostat. It stores system parameters and settings in non-volatile memory (i.e., it retains data when electrical power fails or is turned off).

The iComfort Wi-Fi® thermostat can connect to online services via the Internet through the homeowner's Wi-Fi access point. After online registration is completed, the system may then be accessed by the homeowner from anywhere using a remote Internet connection via computer or personal communicating device.

Refer to page 37 for information on making connections to the thermostat.

User Features and Help (?) Screens

From the Home screen, touch the (?) button to access the Features screen. The Features screen (figure 3) allows you access to edit programs, system settings, display settings, zoning settings, alerts, reminders, service and help (?).

FEATURES

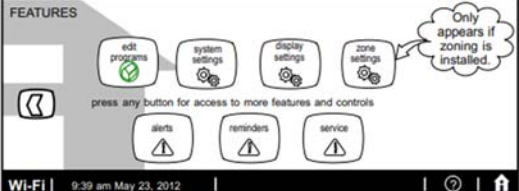

press any button for access to more features and controls

Wi-Fi | 9:39 am May 23, 2012

Figure 3. Features Screen - Indoor Settings

EDIT PROGRAMS (SCHEDULE)

Touch **edit programs** button (see fig. 3). Figure 4 shows the EDIT PROGRAMS screen.

Edit the "season programs" to reflect your preferences. (The **Save energy** program uses high-efficiency Energy Star settings to promote energy conservation.)

- **select programs** - Select a preset program; or touch and hold any button to enable the keyboard to change program names to suit your preferences.
- **select days** - Select week/weekend, individual days, all 7 days.
- **time** - Use up/down arrows to change time in 15 minute increments.
- **cool- and heat-to** - Use up/down arrows to change temperature in 1 degree increments.
- **fan mode** - Select on, auto, or circulate.

In the example in Figure 4, the evening time has been disabled by touching and holding the time button for that time period un time is replaced with **add setting**. To re-enable, touch **add setting** that time period. Use the **restore** button to restore defaults for the preset programs. If no additional adjustment are made to any programs, touch "X" button to exit. If changes are made to any programs then touch the **save** button and then touch **X** to exit this screen and return to the FEATURES screen.

EDIT PROGRAMS

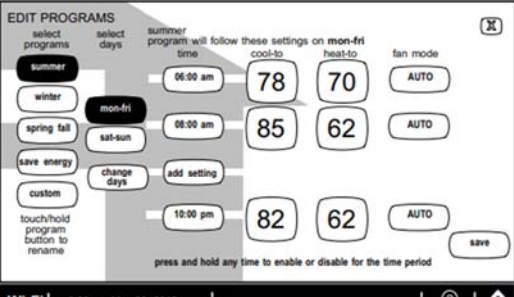

press and hold any time to enable or disable for the time period

Wi-Fi | 9:39 am May 23, 2012

Figure 4. EDIT PROGRAMS Screen

TURN PROGRAMMING ON

If the programming is OFF, touch the system mode button (shown in figure 5, labeled **heat or cool**) to open the manual settings menu. **Programs** is the final selection in this menu. Select **programs** to display the program settings menu. (The menu will disappear if you don't make a selection within a few seconds). Select an option (e.g. **spring/fall**). The system mode button will display the selected program (e.g. **spring...program is ON**).

1(D)(1): establish on said liquid crystal display one or more representations of buttons at a separated and predetermined positions; - For instance, the '075 Accused Products have an LCD (liquid crystal display) having a transparent touch pad, which is an interactive interface displaying graphical icons and text to represent temperature, scheduling of programs, or settings

for rooms.

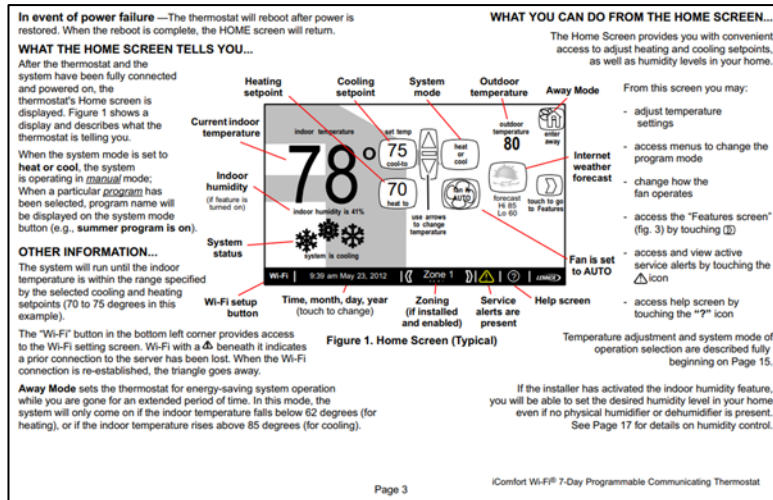

I(D)(2): read the position on the touch pad juxtaposed with said predetermined position to determine if said representation of a button has been touched; and - For instance, in the '075 Accused Products, when Cool mode has been selected, the "Cool" button is displayed at a position on the touch screen.

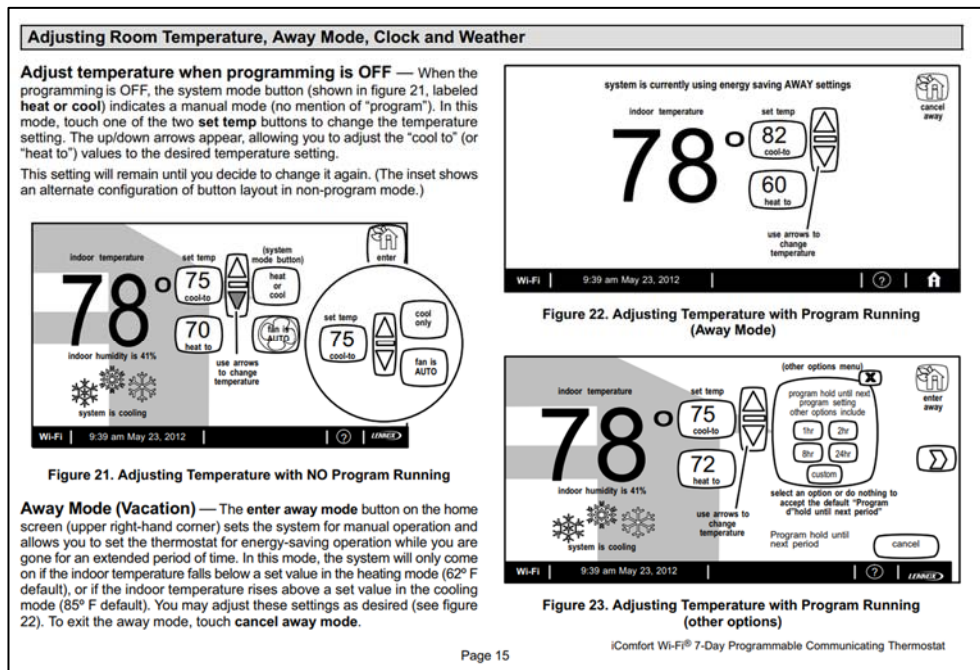

...tion to ensure the keyboard to change program names to suit your preferences.

- **select days** - Select week/weekend, individual days, all 7 days.
- **time** - Use up/down arrows to change time in 15 minute increments.
- **cool- and heat-to** - Use up/down arrows to change temperature in 1 degree increments.
- **fan mode** - Select on, auto, or circulate.

507342-02 Page 6

TURN PROGRAMMING ON
If the programming is OFF, touch the system mode button (shown in figures 5, labeled **heat** or **cool**) to open the manual settings menu. **Programs** is the final selection in this menu. Select **programs** to display the program settings menu. (The menu will disappear if you don't make a selection within a few seconds). Select an option (e.g. **spring/fall**). The system mode button will display the selected program (e.g. **spring...program is ON**).

TURN PROGRAMMING OFF
If the programming is ON, touch the system mode button (e.g. **spring...program is ON**) to return to manual mode. The program settings menu includes an option for manual. Select **manual** to display the manual settings. Select one of the manual settings (e.g. **heat only**). After the selection is made, the **system mode** button will display the selected manual option (e.g. **heat only**).

Figure 5. Turning on the Program

Adjust temperature when program is ON — Program HOLD
When the program is ON, the system mode button (shown in figure 6, labeled **spring...program is ON**) indicates which program is running. In this mode, touch a **set temp** button to trigger the appearance of an up/down arrow. Use the arrows to adjust the temperature setting for the "cool to" (or "heat to") value (see figure 6).

While changing the temperature setting, the **other options** menu appears (see figure 23). This menu provides options for the length of time that you may choose to hold a temperature setting.

Figure 6. Adjusting Temperature with Program Running (cool-to and heat-to)

SYSTEM SETTINGS
For more information concerning humidification and dehumidification, go to page 19.

- Touch **system settings** button from the **FEATURES** screen. Figure 7 shows the **SYSTEM SETTINGS** screen with its defaults. Figure 8 shows how the devices can be configured.
- Touch **set to heating mode** button (**XP25 only**). (button may read: **COMFORT** or **NORMAL**). Select and change by touching heating mode icon: **COMFORT** or **NORMAL**.
- Touch buttons under appropriate humidification or dehumidification setting titles to select preferences.

Humidifier display is visible on the **SYSTEM SETTINGS** screen and can be changed to **OFF** from this screen. The resulting display shows the default values for humidifier and ClimateIQ. Use the arrows to change either.

When **humidity display is ON**, text near the screen bottom shows the current humidity. Touch the "X" button to return to **FEATURES** screen or touch the Home icon to return to the Home screen.

In event of power failure —The thermostat will reboot after power is restored. When the reboot is complete, the HOME screen will return.

WHAT THE HOME SCREEN TELLS YOU...
After the thermostat and the system have been fully connected and powered on, the thermostat's Home screen is displayed. Figure 1 shows a display and describes what the thermostat is telling you.

When the system mode is set to **heat or cool**, the system is operating in **manual** mode; When a particular **program** has been selected, program name will be displayed on the system mode button (e.g., **summer program is on**).

OTHER INFORMATION...
The system will run until the indoor temperature is within the range specified by the selected cooling and heating setpoints (70 to 75 degrees in this example).

The "Wi-Fi" button in the bottom left corner provides access to the Wi-Fi setting screen. Wi-Fi with a **Δ** beneath it indicates a prior connection to the server has been lost. When the Wi-Fi connection is re-established, the triangle goes away.

Away Mode sets the thermostat for energy-saving system operation while you are gone for an extended period of time. In this mode, the system will only come on if the indoor temperature falls below 62 degrees (for heating), or if the indoor temperature rises above 85 degrees (for cooling).

WHAT YOU CAN DO FROM THE HOME SCREEN...
The Home Screen provides you with convenient access to adjust heating and cooling setpoints, as well as humidity levels in your home.

From this screen you may:

- adjust temperature settings
- access menus to change the program mode
- change how the fan operates
- access the "Features screen" (fig. 3) by touching **Ⓜ**
- access and view active service alerts by touching the **⚠** icon
- access help screen by touching the "?" icon

Temperature adjustment and system mode of operation selection are described fully beginning on Page 15.

If the installer has activated the indoor humidity feature, you will be able to set the desired humidity level in your home even if no physical humidifier or dehumidifier is present. See Page 17 for details on humidity control.

Figure 1. Home Screen (Typical)

Page 3 iComfort Wi-Fi® 7-Day Programmable Communicating Thermostat

I(D)(3): if said a representation of a button has been touched, processing this information to establish a condition incorporated into the operation of said thermostat system;— For example, when the representation of a button has been touched, processing this

information, the operation of the thermostat responds accordingly.

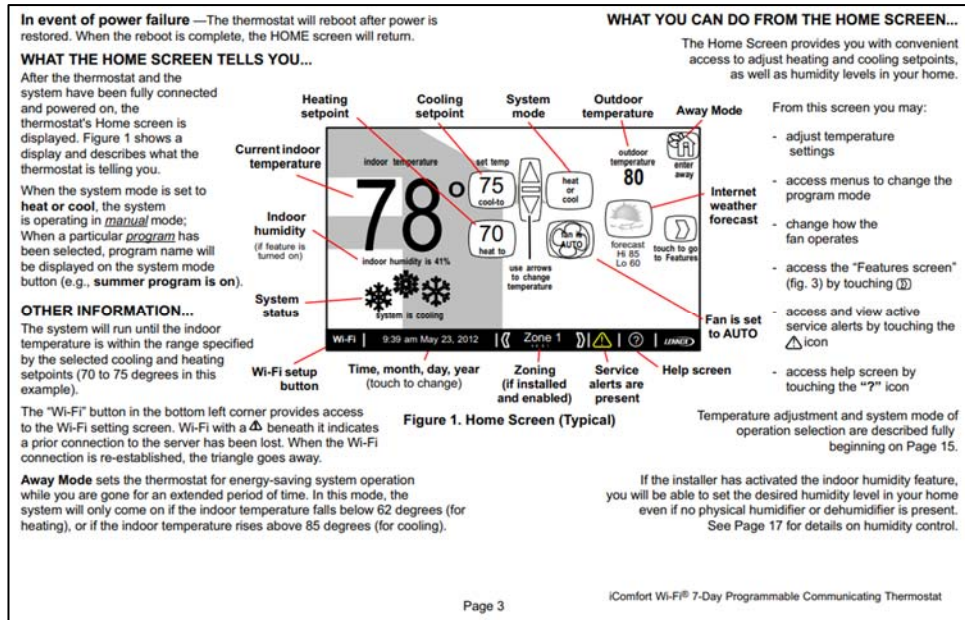

I(D)(4): establish communications between said processor and a first remote correspondent from which is transferred to said memory one or more modules of functional programming; and; - For instance, the '075 Accused Products include a processor, which communicates with a first remote correspondent (e.g. heater, cooler, humidifier and fan), which is transferred to memory.

TURN PROGRAMMING OFF
 If the programming is ON, touch the system mode button (e.g. **spring...program is ON**) to return to manual mode. The program settings menu includes an option for manual. Select **manual** to display the manual settings. Select one of the manual settings (e.g. **heat only**). After the selection is made, the system mode button will display the selected manual option (e.g. **heat only**).

Figure 5. Turning on the Program

Adjust temperature when program is ON — Program HOLD
 When the program is ON, the system mode button (shown in figure 6, labeled **spring...program is ON**) indicates which program is running. In this mode, touch a **set temp** button to trigger the appearance of an up/down arrow. Use the arrows to adjust the temperature setting for the “cool to” (or “heat to”) value (see figure 6).
 While changing the temperature setting, the **other options** menu appears (see figure 23). This menu provides options for the length of time that you may choose to hold a temperature setting.

Figure 6. Adjusting Temperature with Program Running (cool-to and heat-to)

SYSTEM SETTINGS
 For more information concerning humidification and dehumidification, go to page 19.

- Touch **system settings** button from the **FEATURES** screen. Figure 7 shows the **SYSTEM SETTINGS** screen with its defaults. Figure 8 shows how the devices can be configured.
- Touch **set to heating mode button (XP25 only)**. (button may read: **COMFORT** or **NORMAL**). Select and change by touching heating mode icon: **COMFORT** or **NORMAL**.
- Touch buttons under appropriate humidification or dehumidification setting titles to select preferences.

Humidifier display is visible on the **SYSTEM SETTINGS** screen and can be changed to **OFF** from this screen. The resulting display shows the default values for **humidifier** and **ClimateIQ**. Use the arrows to change either. When **humidity display is ON**, text near the screen bottom shows the current humidity. Touch the “X” button to return to **FEATURES** screen or touch the Home icon to return to the Home screen.

Page 7 iComfort Wi-Fi® 7-Day Programmable Communicating Thermostat

Figure 7. SYSTEM SETTINGS Screen (Example Only) - Communicating Indoor Unit

Figure 8. SYSTEM SETTINGS Screen - Making Adjustments

DISPLAY SETTINGS
 Touch **display settings** from the **FEATURES** screen (see figure 3). Figure 9 shows the **DISPLAY SETTINGS** screen and defaults.

- Touch **Temp scale** button to toggle between °F and °C options.
- Touch **Background theme**, **screen saver**, **screen lockout**, **language**, **outdoor temp display** buttons to select options from pop-up menus (figure 10).
- Touch **backlight intensity** button and use up/down arrows to change the intensity of backlighting in 20% increments.

Touch the **press** to **CLEAN SCREEN** button to enable a 30-second touchscreen lock to allow screen cleaning. Use a damp cloth to clean the screen.

Figure 9. Display Settings (defaults)

Figure 13. Registration Screen

NOTE - This following information is customer setup instructions and is shown here to allow the installer to help walk the customer through the setup process.

After registering through your iComfortWi-Fi® thermostat interface, go to the homeowner's computer and locate the email sent from the server.

NOTE - If the customer has already setup an account, click the "Click Here" button to access that account.

Click on the Register link; the screen (to the left) will appear. Fill in the User Name and Password fields and check the agree to terms and conditions box. Click **Create User** button.

507341-0212

Adding Non-Communicating Outdoor Unit and Accessories

OUTDOOR UNIT (AIR CONDITIONER OR HEAT PUMP)

To add (or remove) an outdoor unit that is not iComfort®-enabled, you must be at the "Add or Remove Non-communicating equipment?" screen.

1. Touch the **yes** button next to **Add or Remove Non-communicating equipment?**
2. In the "non-communicating device list" screen, use the arrows to highlight **Outdoor Unit Type** and touch **edit**.
3. Touch one of the radio buttons to select a 1-or 2-stage air conditioner unit or a 1-or 2-stage heat pump unit; touch **save**.
4. Use arrows to highlight any red colored text in the device list (e.g. select **Outdoor Unit Capacity**; text turns white). Touch **edit**.

5. Use either the up or down arrows to display the correct size outdoor unit. Touch **save** to continue.

NOTE - If the defaults are correct, you do not have to make any changes, but you must touch save. When all red text is gone, the back button will appear; touch it to return to the "Add or Remove Non-communicating equipment?" screen.

ADDING A HUMIDIFIER

Before adding a humidifier, be sure that the:

- Humidifier is wired to the furnace or air handler control as shown on the Optional Accessories wiring diagram (see page 42).
- Entire system is wired, powered up, and the thermostat has detected the system's installed communicating devices, and you are at the "Add or Remove Non-communicating equipment?" screen.

To add (or remove) a humidifier:

1. Touch the **yes** button on this screen.
2. In the "non-communicating device list" screen, use the arrows to highlight **Humidifier** (note the current value, **Not Installed**) and touch **edit**.
3. Touch one of the radio buttons to select the type of humidifier (or select **Not Installed**, if removing humidifier); touch **save**.
4. The previous screen returns, but the current value now shows your selection. Touch the **back** button.
5. The "Add or Remove..." screen reappears with your addition shown in the system devices list. At this point, you may add more equipment (touch **yes**) or if finished, touch the **next** button to advance to the "Adjust a setting..." screen (see page 15).

NOTE - Adding humidity regulating non-communicating devices may be a 2-step procedure:

- **First** the device must be installed and wired. After the humidifier is installed, the setting under the "System" mode "Humidification Control Mode" defaults to "Basic".
- **Second**, if you want another mode, i.e. Precision, Basic Dew Point, or Precision Dew Point, the device requires further configuration (see page 15).

ADDING HUMIDITROL® OR AN AUXILIARY DEHUMIDIFIER

Before adding a dehumidifier, be sure that:

- the dehumidifier is wired to the furnace or air handler control as shown on the Optional Accessories wiring diagram (see page 42).
- the entire system is wired, powered up, and the thermostat has detected the system's installed communicating devices, and you are at the "Add or Remove Non-communicating equipment?" screen.

To add (or remove) a dehumidifier, you must be at the "Add or Remove Non-communicating equipment?" screen.

1. Touch the **yes** button on this screen.
2. In the "non-communicating device list" screen, use the arrows to highlight **Dehumidifier** and touch **edit**. Note the current value (e.g. Not Installed).
3. Touch one of the radio buttons to select the type of dehumidifier (or select **Not Installed**, if removing dehumidifier); touch **save**.
4. When you scroll to the Dehumidifier device, (Note the current value, e.g. Humiditrol.) Click **back** to return to the "Add or Remove..." screen.
5. The "Add or Remove..." screen reappears with your addition shown in the system devices list. At this point, you may add more equipment (touch **yes**) or if finished, touch the **next** button to advance to the "Adjust a setting..." screen.

NOTE - Adding humidity regulating non-communicating devices may be a 2-step procedure:

- **First** the device must be installed and wired. After the dehumidifier is installed, the setting under the "System" mode "Dehumidification Control Mode" defaults to "Basic".
- **Second**, set Humiditrol® comfort adjust overcooling and the min/max dehumidification setpoints if desired (see page 16).

1(D)(5): operate said transferred functional programming to change or add to representations on the touch screen, where said changes or additions of representation on the touch screen were not available to the control program before their transfer to the memory; -

For instance, in the '075 Accused Products, a user may read the position of the button on the touch screen to see if it has been pressed (e.g., when placed into Cool mode, the predetermined position of the Cool button is represented on the touch pad). A communication interface is also included on the touchscreen, allowing the thermostat processor to connect with heaters, humidifiers, air conditioners, or fans (the remote correspondent devices).

1(E): means coupling said communications interface and said first remote correspondent - For instance, the '075 Accused Products connect to a remote correspondent such

as fans, humidifiers, or any other space conditioning equipment.

In event of power failure —The thermostat will reboot after power is restored. When the reboot is complete, the HOME screen will return.

WHAT THE HOME SCREEN TELLS YOU...
After the thermostat and the system have been fully connected and powered on, the thermostat's Home screen is displayed. Figure 1 shows a display and describes what the thermostat is telling you.

When the system mode is set to **heat or cool**, the system is operating in *manual* mode; When a particular *program* has been selected, program name will be displayed on the system mode button (e.g., **summer program is on**).



OTHER INFORMATION...
The system will run until the indoor temperature is within the range specified by the selected cooling and heating setpoints (70 to 75 degrees in this example).

The "Wi-Fi" button in the bottom left corner provides access to the Wi-Fi setting screen. Wi-Fi with a  beneath it indicates a prior connection to the server has been lost. When the Wi-Fi connection is re-established, the triangle goes away.

Away Mode sets the thermostat for energy-saving system operation while you are gone for an extended period of time. In this mode, the system will only come on if the indoor temperature falls below 62 degrees (for heating), or if the indoor temperature rises above 85 degrees (for cooling).

WHAT YOU CAN DO FROM THE HOME SCREEN...
The Home Screen provides you with convenient access to adjust heating and cooling setpoints, as well as humidity levels in your home.

From this screen you may:

- adjust temperature settings
- access menus to change the program mode
- change how the fan operates
- access the "Features screen" (fig. 3) by touching 
- access and view active service alerts by touching the  icon
- access help screen by touching the "?" icon

Temperature adjustment and system mode of operation selection are described fully beginning on Page 15.

If the installer has activated the indoor humidity feature, you will be able to set the desired humidity level in your home even if no physical humidifier or dehumidifier is present. See Page 17 for details on humidity control.

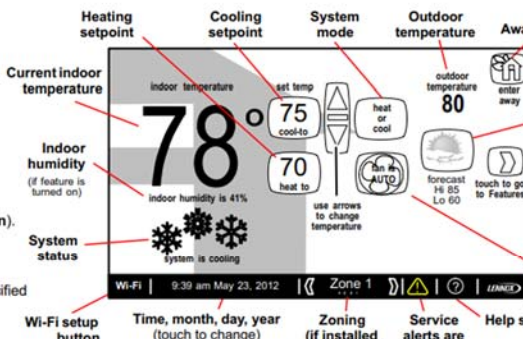
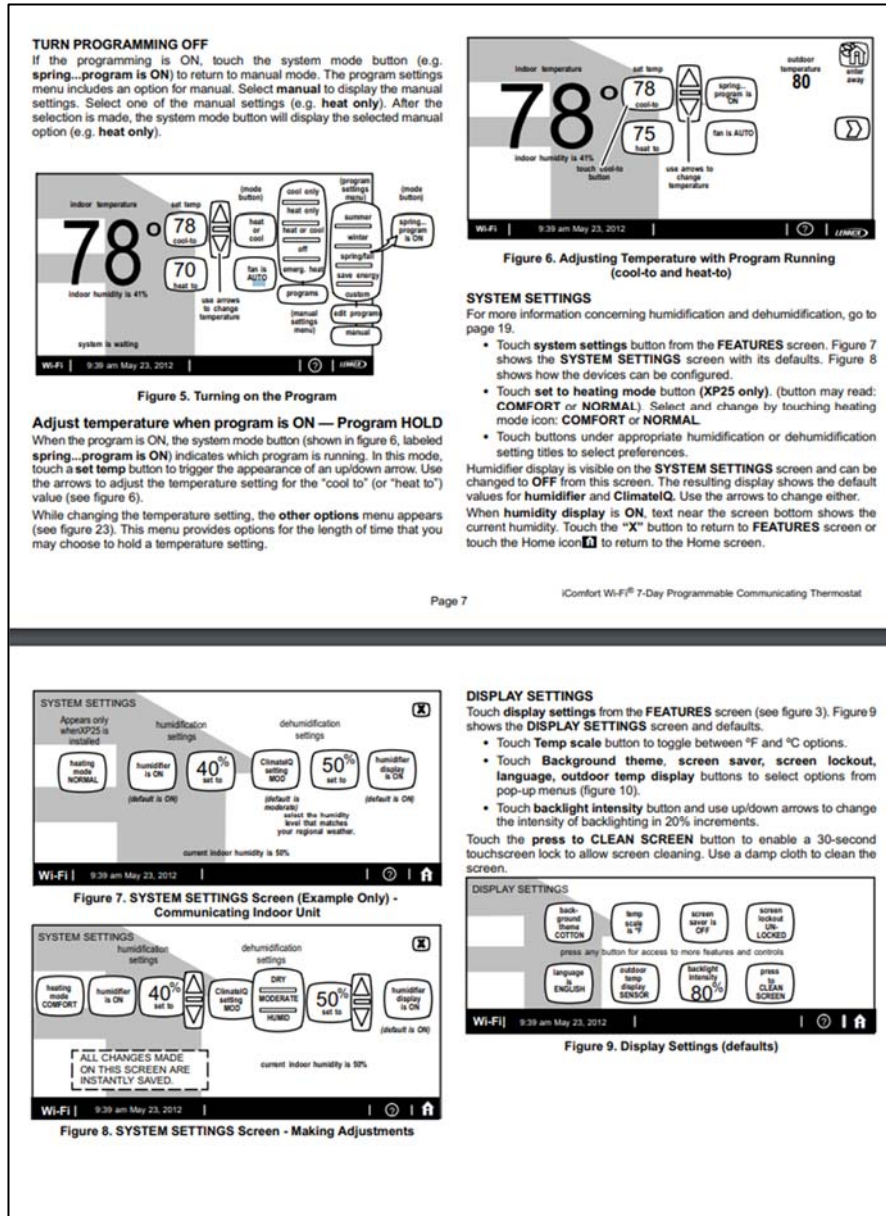

Figure 1. Home Screen (Typical)

Page 3

iComfort Wi-Fi® 7-Day Programmable Communicating Thermostat



TURN PROGRAMMING OFF
 If the programming is ON, touch the system mode button (e.g. **spring...program is ON**) to return to manual mode. The program settings menu includes an option for manual. Select **manual** to display the manual settings. Select one of the manual settings (e.g. **heat only**). After the selection is made, the system mode button will display the selected manual option (e.g. **heat only**).

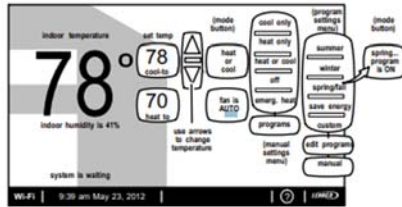

Figure 5. Turning on the Program

Adjust temperature when program is ON — Program HOLD
 When the program is ON, the system mode button (shown in figure 6, labeled **spring...program is ON**) indicates which program is running. In this mode, touch a **set temp** button to trigger the appearance of an up/down arrow. Use the arrows to adjust the temperature setting for the "cool to" (or "heat to") value (see figure 6).
 While changing the temperature setting, the **other options** menu appears (see figure 23). This menu provides options for the length of time that you may choose to hold a temperature setting.

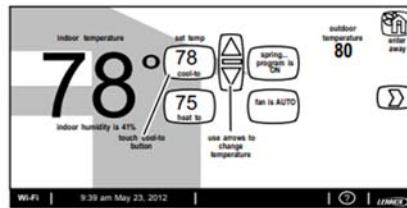

Figure 6. Adjusting Temperature with Program Running (cool-to and heat-to)

SYSTEM SETTINGS

For more information concerning humidification and dehumidification, go to page 19.

- Touch **system settings** button from the **FEATURES** screen. Figure 7 shows the **SYSTEM SETTINGS** screen with its defaults. Figure 8 shows how the devices can be configured.
- Touch **set to heating mode button (XP25 only)**. (button may read: **COMFORT** or **NORMAL**). Select and change by touching heating mode icon: **COMFORT** or **NORMAL**.
- Touch buttons under appropriate humidification or dehumidification setting titles to select preferences.

Humidifier display is visible on the **SYSTEM SETTINGS** screen and can be changed to **OFF** from this screen. The resulting display shows the default values for humidifier and ClimatIQ. Use the arrows to change either. When **humidity display is ON**, text near the screen bottom shows the current humidity. Touch the "X" button to return to **FEATURES** screen or touch the Home icon to return to the Home screen.

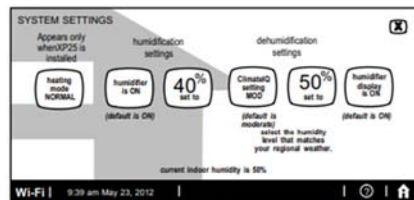

Figure 7. SYSTEM SETTINGS Screen (Example Only) - Communicating Indoor Unit

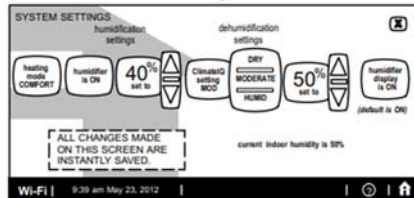

Figure 8. SYSTEM SETTINGS Screen - Making Adjustments

DISPLAY SETTINGS

Touch **display settings** from the **FEATURES** screen (see figure 3). Figure 9 shows the **DISPLAY SETTINGS** screen and defaults.

- Touch **Temp scale** button to toggle between °F and °C options.
- Touch **Background theme**, **screen saver**, **screen lockout**, **language**, **outdoor temp display** buttons to select options from pop-up menus (figure 10).
- Touch **backlight intensity** button and use up/down arrows to change the intensity of backlighting in 20% increments.

Touch the **press to CLEAN SCREEN** button to enable a 30-second touchscreen lock to allow screen cleaning. Use a damp cloth to clean the screen.

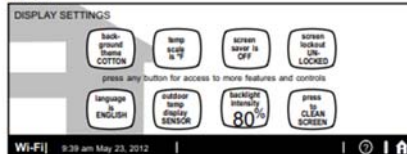

Figure 9. Display Settings (defaults)

113. At least as early as of the date of the filing of the Complaint, Defendant has had actual knowledge of the '075 Patent.

114. Additionally, Defendant contributorily infringes at least one or more claims of the '075 Patent by providing the '075 Accused Products and/or software components thereof, that embody a material part of the claimed inventions of the '075 Patent, that are known by Defendant to be specially made or adapted for use in an infringing manner, and are not staple

articles with substantial non-infringing uses. The '075 Accused Products are specially designed to infringe at least one or more claims of the '075 Patent, and their accused components have no substantial non-infringing uses. In particular, on information and belief, the software modules and code that implement and perform the infringing functionalities identified above are specially made and adapted to carry out said functionality and do not have any substantial non-infringing uses.

115. At least as early as the filing and/or service of this Complaint, Defendant's infringement of the '075 Patent was and continues to be willful and deliberate, entitling Rosen to enhanced damages.

116. Additional allegations regarding Defendant's knowledge of the '075 Patent and willful infringement will likely have evidentiary support after a reasonable opportunity for discovery.

117. Defendant's infringement of the '075 Patent is exceptional and entitles Rosen to attorneys' fees and costs incurred in prosecuting this action under 35 U.S.C. § 285.

118. Rosen is in compliance with any applicable marking and/or notice provisions of 35 U.S.C. § 287 with respect to the '075 Patent.

119. Rosen is entitled to recover from Defendant all damages that Rosen has sustained as a result of Defendant's infringement of the '075 Patent, including, without limitation, a reasonable royalty.

PRAYER FOR RELIEF

WHEREFORE, Rosen respectfully requests:

A. That Judgment be entered that Defendant has infringed at least one or more claims of the Asserted Patents, directly and/or indirectly, literally and/or under

the doctrine of equivalents;

B. An award of damages sufficient to compensate Rosen for Defendant's infringement under 35 U.S.C. § 284, including an enhancement of damages on account of Defendant's willful infringement;

C. That the case be found exceptional under 35 U.S.C. § 285 and that Rosen be awarded its reasonable attorneys' fees;

D. Costs and expenses in this action;

E. An award of prejudgment and post-judgment interest; and

F. Such other and further relief as the Court may deem just and proper.

DEMAND FOR JURY TRIAL

Pursuant to Rule 38(b) of the Federal Rules of Civil Procedure, Rosen respectfully demands a trial by jury on all issues triable by jury.

Respectfully submitted,

Dated: March 31, 2022

By: /s/ Hao Ni

Hao Ni

Texas Bar No. 24047205

hni@nilawfirm.com

Neal Massand

Texas Bar No. 24039038

nmassand@nilawfirm.com

Timothy T. Wang

Texas Bar No. 24067927

twang@nilawfirm.com

Stevenson Moore V

Texas Bar No. 24076572

smoore@nilawfirm.com

NI, WANG & MASSAND, PLLC

8140 Walnut Hill Ln., Ste. 500

Dallas, TX 75231

Tel: (972) 331-4600

Fax: (972) 314-0900

Attorney for Plaintiff

Rosen Technologies LLC