

1 J. MARK HOLLAND (140453)  
2 **J. MARK HOLLAND & ASSOCIATES**  
3 a Professional Law Corporation  
4 19800 MacArthur Boulevard, Suite 300  
5 Irvine, CA 92612  
6 Telephone: (949) 718-6750  
7 Facsimile: (949) 718-6756  
8 Email: office@jmhlaw.com

9 Attorneys for Plaintiff RESH, INC.

10 UNITED STATES DISTRICT COURT  
11 NORTHERN DISTRICT OF CALIFORNIA

12 RESH, Inc. a California corporation,  
13 Plaintiff,

14 vs.

15 SKIMLITE MANUFACTURING  
16 INC., a California corporation;  
17 JAMES R. CONRAD, an individual;  
18 BARRETT CONRAD, an individual;  
19 and DOES 1 THROUGH 5,  
20 inclusive, )

21 Defendants.

Civil Action No. \_\_\_\_\_

**COMPLAINT FOR PATENT  
INFRINGEMENT**

**JURY TRIAL DEMANDED**

22 **OVERVIEW**

23 1. This Complaint may be longer than most patent infringement  
24 complaints. There are several reasons for this. Many or all of those reasons are  
25 based on actions that Defendants have taken over the past several years (as  
26 hopefully will become apparent upon review of the Complaint). Those reasons  
27 include at least the following:

28 (a) Defendants have asserted that they have evidence of allegedly  
invalidating prior art, but they have refused to share with Plaintiff critical  
pieces of that alleged “evidence”;

(b) this is one of the rare patent infringement cases in which Defendants’

1 actions and the relevant facts and law show that **pre-issuance damages**  
2 are appropriate. Plaintiff attempts herein to describe the relevant facts  
3 and law on that issue, to support the Court awarding those **pre-issuance**  
4 damages to Plaintiff;

5 (c) Over the past several years, Defendants have been infringing other of  
6 Plaintiff's related patents, and the details of Defendants' actions in that  
7 regard support the Court finding that Defendants' infringement is **willful**,  
8 supporting the Court's award to Plaintiff of **enhanced damages**; and

9 (d) Defendants have admitted both (i) infringement and (ii) that their  
10 infringing products are becoming Defendants' customers' "favorites,"  
11 and Plaintiff attempts herein to adequately document those admissions  
12 (to save the Court and the parties future time and effort litigating those  
13 issues).

14 2. In view of the Complaint's length, Plaintiff has included this  
15 introductory Overview. The remainder of the Complaint is intended to provide  
16 sufficient details to enable the Court and the parties to efficiently litigate this  
17 dispute. In addition to the reasons listed above, Plaintiff has attempted in the  
18 Complaint to set forth some of the good faith bases (in both fact and law) for the  
19 relief Plaintiff seeks from the Court. In addition, Plaintiff hopes that the detail in  
20 the Complaint (and the correspondingly detailed Answer required from  
21 Defendants) will eliminate or reduce discovery and/or motion practice for at least  
22 some of these issues, thereby reducing the overall burden of this lawsuit for both  
23 the Court and the parties.

24 3. Almost 70 years ago (around 1954), Robert Conrad (Defendant Jim  
25 Conrad's father and Defendant Barrett Conrad's grandfather) started their family  
26 business Defendant Skimlite, and began making telescoping swimming pool poles.

27 4. Just a few years later, around 1959, Defendant Jim Conrad began  
28

1 working at Skimlite. Upon information and belief, Defendant Jim Conrad has  
2 worked at Skimlite his entire adult life since then, through the ensuing six decades.  
3 Defendant Barrett Conrad began working at Skimlite more recently, and is the  
4 third generation in their family to be involved in the Skimlite pool pole business.

5 5. Starting in the 1950s, and continuing for more than 60 years, the  
6 Defendants made/manufactured/sold telescoping swimming pool poles, **all** of  
7 which were “locked” at a desired length by the user twisting or clamping the  
8 telescoping tubes. Some of Defendants’ poles had elliptic cross-sections on the  
9 telescoping tubes, and when a user twisted those tubes, those elliptical shapes  
10 “locked” the tubes with each other. In other models, Defendants’ poles included  
11 one or more internal cam elements that “locked” when the user twisted the tubes  
12 relative to each other. Defendants also added external clamps and/or nuts on some  
13 models, to accomplish or improve the “lock” of the tubes at a desired length.

14 6. When Defendants were launching their dominance of the swimming  
15 pool pole industry (making those twisting/clamping telescoping swimming pool  
16 poles), Plaintiff’s inventor Eric Resh had not even been born. It was not until more  
17 than 35 years later (in 1989) that Mr. Resh even began working as a pool man,  
18 cleaning swimming pools for homeowners in southern California. When cleaning  
19 his customers’ pools, Mr. Resh even used twisting/clamping poles made and sold  
20 by Defendants.

21 7. An additional 25 years later (in 2012), Mr. Resh and his company  
22 introduced their **own** telescoping swimming pool pole. It was the first pole Mr.  
23 Resh and/or Plaintiff had ever made and/or sold. Since then, the Patent Office has  
24 issued **three** separate patents to Plaintiff for Plaintiff’s pole inventions.<sup>1</sup> Among  
25

---

26 <sup>1</sup> This suit is focused on Plaintiff’s U.S. Pat. No. 11,141,852 (the ‘852 Patent;  
27 Exhibit A hereto). Because of the infringement and past/ongoing behavior by  
28 Defendants and others described herein (among other reasons), Plaintiff has filed  
additional pending related patent applications. Plaintiff hopes and expects that the

1 other features, Plaintiff's new pole inventions get rid of the need for twisting or  
2 clamping to set the pole's length. For that reason, Plaintiff's inventions are a stark  
3 challenge to Defendants' "old style" products and to Defendants' decades of  
4 making and selling those old-style twisting/clamping poles.

5 8. As mentioned above, Defendant Jim Conrad has spent his entire adult  
6 life working at Defendant Skimlite, making and selling swimming pool poles. As  
7 discussed in more detail in Exhibit B,<sup>2</sup> Jim Conrad was so shocked by Plaintiff's  
8 pole inventions that he gasped when he first saw them.

9 9. A few years after seeing Plaintiff's ground-breaking pole inventions,  
10 Defendants began copying those inventions, and Defendants' ongoing and repeated  
11 copying now has prompted the present lawsuit. Upon information and belief,  
12 Defendants' infringement began in earnest at least as early as 2015. After seeing  
13 the success of Plaintiff's new-style poles, Defendants secretly began copying  
14 Plaintiff's swimming pool pole inventions. Within months after Plaintiff obtained  
15 a first patent for Plaintiff's pole inventions (in late 2017), Plaintiff became aware  
16 of Defendants' previously-secret copying. Plaintiff sued Defendants in 2018 for  
17 infringing that first patent, and forced Defendants to stop making the Defendants'  
18 then-existing version of Plaintiff's pole inventions.

19 10. Plaintiff recently obtained two additional patents on Plaintiff's pole  
20 inventions. **Defendants have at various times infringed all three of Plaintiff's**  
21 **swimming pool pole patents.** Although Defendants have indicated that they have  
22

---

23 Patent Office will grant additional protection for the many aspects of Plaintiff's  
24 inventions that Defendants (and those other infringers) obviously find to be so very  
25 valuable that they all have copied Plaintiff's inventions.

26 <sup>2</sup> Exhibit B is a true and correct copy of portions of Plaintiff's filings in the  
27 U.S. Patent Office that eventually led the Office to grant the '852 patent. Pages  
28 numbered 124-129 at the bottom (within the body of the copies in that Exhibit B)  
are true and correct descriptions of Defendants James Conrad's initial and  
unrehearsed reaction to seeing Plaintiff's '852 Patent inventions, and a brief  
discussion of related case law regarding the importance of such evidence.

1 stopped infringing one of those patents, Defendants have refused to stop infringing  
2 the other patent (the ‘852 Patent). As a result, Plaintiff has no alternatives other  
3 than to (a) abandon its most-recent patent, or (b) file this lawsuit.

4 11. Defendants have been aware of Plaintiff’s pending patent claims for  
5 years, including by virtue of the parties’ 2018 lawsuit. During all that time,  
6 Defendants have **never** offered any argument that Defendants do not infringe that  
7 patent. In fact, Defendants instead have effectively admitted that they **do** infringe  
8 that patent.

9 12. In fact, it was not until a few months ago (and after the Patent Office had  
10 issued that third patent to Plaintiff) that Defendants even alleged **any** “defense” to  
11 the ‘852 patent. As mentioned above, Defendants already have admitted that they  
12 are infringing the patent. Defendants therefore finally (but only very recently)  
13 alleged that the ‘852 patent is invalid. As discussed in further detail below,  
14 Defendants’ apparently main allegations are based on evidence that is insufficient  
15 as a matter of law.<sup>3</sup> Specifically, Defendants have alleged the existence of  
16 invalidating prior art, of a third party who allegedly made and used the invention  
17 more than 20 years ago. Defendants have only supported their allegations by oral  
18 testimony. For over a hundred years, the Supreme Court and other courts have  
19 rejected such “oral testimony” as being insufficient to establish prior art for  
20 invalidating a patent.

21 13. As a result of admitting their infringement and not having any other  
22 meaningfully supported defense, Defendants have been and are willfully infringing  
23 Plaintiff’s patent. Plaintiff seeks relief from this Court, to stop that infringement,  
24

---

25 <sup>3</sup> Defendants’ apparently “main” allegation of invalidity is based on an alleged  
26 “A.G. Pro Pole” (discussed herein). Defendants also included a short list of other  
27 potential defenses, none of which appear to be of much potential consequence.  
28 Those alleged defenses are such that it seems possible that Defendants may not  
even include them as defenses in this lawsuit. If Defendants do, Plaintiff will  
address them at that time.

1 to compensate Plaintiff, and to punish Defendants for their ongoing and willful  
2 infringement.

### 3 THE PARTIES

4 14. Plaintiff Resh, Inc. (“Resh”) is a California corporation having a  
5 principal place of business at 41725 Elm Street, Suite 103, Murrieta, California  
6 92562. Eric Resh and his wife, Jenel Gonzalez Resh, are the principals and owners  
7 of Plaintiff Resh, Inc.  
8

9 15. Upon information and belief, Defendant Skimlite Manufacturing Inc.  
10 (“Skimlite”) is a corporation existing under the laws of the State of California, with  
11 a principal place of business at 1518 Moffett Street, Suite E, Salinas, CA 93905.

12 16. Upon information and belief, Defendant James R. Conrad (“James  
13 Conrad” and/or “Jim Conrad”), is an individual residing in or near Salinas, CA, is a  
14 principal of Defendant Skimlite, and has a business/service address of 1518  
15 Moffett Street, Suite E, Salinas, CA 93905.

16 17. Upon information and belief, Defendant Barrett Conrad (“Barrett  
17 Conrad”), is an individual residing in or near Salinas, CA, is a principal of  
18 Defendant Skimlite, and has a business/service address of 1518 Moffett Street,  
19 Suite E, Salinas, CA 93905.

20 18. The true names and capacities of Doe Defendants 1 through 5 are not  
21 known to Resh at this time, and Resh therefore sues them under fictitious names.  
22 When the actual identities of Does 1 through 5 are determined, Resh intends to  
23 seek leave of Court to amend this Complaint to name such persons as Doe  
24 Defendants. Resh is informed and believes, and thereon alleges, that Does 1  
25 through 5 participated in the wrongful acts described herein, and are responsible in  
26 some way for the wrongful acts alleged herein. Accordingly, as indicated above  
27 and depending on the context in which it is used herein, the term “Defendants” is  
28 intended to include not only “Skimlite” and “James Conrad” and “Barrett Conrad,”

1 but also any and/or all other Defendants or any individuals or other entities acting  
2 on behalf of or in coordination with the named Defendants regarding the matters  
3 discussed herein.

4 **JURISDICTION AND VENUE**

5 19. This lawsuit is a civil action for patent infringement arising under the  
6 patent laws of the United States, Title 35, United States Code, and more particularly  
7 under the United States Patent Act 35 U.S.C. §§1 et seq., including 35 U.S.C. §271.

8 20. This Court has subject matter jurisdiction over this action pursuant to 28  
9 U.S.C. §§1331 and 1338(a).

10 21. This Court has personal jurisdiction over the Defendants consistent with  
11 the principles of due process, by virtue of one or more of the following:

- 12 - the Defendants transacting and doing business in this District,
- 13 - because a substantial part of the relevant events occurred in this District,
- 14 and/or
- 15 - because a substantial part of the property that it is the subject of this  
16 action is situated here.

17 22. Venue is proper in this judicial District pursuant to 28 U.S.C. §1400(b).  
18 Defendants reside in this district, have committed acts of patent infringement in this  
19 district, and have a regular and established place of business in this district.

20 **PATENT-IN-SUIT**

21 **(U.S. PATENT NO. 11,141,852; THE ‘852 PATENT)**

22 23. Resh realleges and incorporates by reference the allegations set forth in  
23 paragraphs 1-22.

24 24. In this lawsuit, Plaintiff is asserting that Defendants have infringed and  
25 are infringing Plaintiff’s U.S. Pat. No. 11,141,852, entitled “Telepole Apparatus  
26 and Related Methods” (the ‘852 Patent).

27 25. On October 12, 2021, the United States Patent and Trademark Office  
28

1 duly and legally issued the '852 Patent. The '852 Patent is presumed valid and  
2 enforceable. A true and correct copy of the '852 Patent is attached as Exhibit A.

3 26. Plaintiff is the assignee of all right, title and interest in the '852 Patent,  
4 including all rights to enforce and prosecute actions for infringement and to collect  
5 damages for all relevant times against infringers of the '852 Patent. Plaintiff has  
6 never authorized Defendants, or any of them, to practice any of the inventions  
7 covered by the '852 Patent.

8 27. Among other things, and relevant to this lawsuit, the '852 Patent relates  
9 to telescoping poles and related assemblies for cleaning swimming pools. Poles  
10 for cleaning swimming pools commonly can be attached to nets and brushes and/or  
11 other cleaning tools, and the poles themselves commonly include telescoping tubes  
12 (that a user can slide in or out of each other adjust the pole to a desired length).  
13 The adjustable length provided by the telescoping tubes allows the user to reach  
14 and/or move the cleaning tool across various areas of the pool being cleaned.



1 28. As mentioned above, prior to Plaintiff's '852 Patent inventions, the  
 2 length adjustment process typically involved "twisting" and/or "clamping" the  
 3 tubes into or out of engagement at a selected length. Defendants have made these  
 4 types of "twisting" and/or "clamping" poles for decades, as shown in the following  
 5 screenshot/excerpt from Defendants' website<sup>4</sup>:

6 **Defendants' Decades-Old Twisting/Clamping Poles**



20 29. In the photographs above, four show the handle ends of two separate  
 21 poles crossing each other (the bottom center photograph shows a single pole). As  
 22 further explained below, the screenshot above has been edited very slightly, to  
 23 white out the upper right quadrant, because that quadrant is where Defendants  
 24

25

26 <sup>4</sup> Because most telescoping swimming pool poles are so long (for example, 8-  
 27 foot when collapsed is common), it is common for promotional photographs (like  
 28 the ones here) to only show the "gripping ends" of the poles (not the entire pole).  
 Otherwise, the product itself would be too small to see well in a photograph.

1 display their infringing copycat poles.

2 30. Below is another copy of that same screenshot of Defendants’ poles, that  
3 has been marked up to illustrate how Defendants’ and other prior art “twist/clamp”  
4 telescoping swimming pool poles are used. To lock the pole at a selected length,  
5 those poles typically require the user to:

6 (a) grasp the two separate tubes (such as at the locations marked 1 and 2  
7 on any one of the poles; color-coded to distinguish the “crossed” poles from each  
8 other);

9 (b) twist the tubes in opposite directions to “unlock” the tubes (so that  
10 the user can slide the poles to a different length);

11 (c) slide the tubes to a desired length/position with respect to each other;

12 (d) twist the tubes in opposite directions to “lock” the tubes (so that the  
13 poles will stay at that selected length); and/or

(e) for some versions with “extra locking” features, operate an external clamp or nut (such as shown by the green arrows below):

**Defendants’ Decades-Old Twisting/Clamping Poles**  
**(WITH Mark-Up Showing TWISTING Required to Lock Pole Length)**



31. During cleaning of even a single pool, it is common to adjust the pole’s length repeatedly. Each length adjustment of these prior art poles requires first undoing the current “lock,” sliding the tubes to the new length, and resetting the lock using the steps above.

32. These prior art swimming pool poles have other problems besides the complexity of adjusting the poles’ length. For example, because the tubes are just “twisted” into engagement (by friction), sometimes the tubes can “disengage” from each other during the pool cleaning. To avoid that problem, users sometimes keep the tubes “torqued” during use (by applying a twisting pressure on the pole the entire time of using it). On information and belief, the external nuts and clamps

1 were added to try to address that problem, but those features obviously require  
2 additional parts and maintenance, and they add weight to the pole assembly.  
3 Perhaps as importantly, those nuts/clamps themselves require additional  
4 “twisting/clamping” action by the user, to engage/disengage them and try to make  
5 the pole’s engagement more secure. Other problems exist. Users sometimes  
6 “overtighten” the tubes, making it very difficult to disengage the tubes at a later  
7 time (users disengage the tubes to adjust the pole length, or to collapse the pole  
8 when the pool cleaning is completed). The complicated unlocking and locking  
9 process (to set the pole’s length) requires extra time and effort to reset the pole to  
10 the desired length, and (especially cumulatively) can make pool cleaning take more  
11 time and be less efficient. For professional pool men cleaning pools for a living,  
12 the cumulative extra time/effort required by these prior art poles can reduce the  
13 profitability of their businesses.

14 33. Perhaps the worst problem caused by prior art telescoping poles can be  
15 that they can cause physical harm to the users. For some users (such as pool men  
16 like Mr. Resh in the past, who clean multiple swimming pools every day, as a full-  
17 time job), this cumulative and repeated twisting/clamping action sometimes  
18 damages their wrists, even causing symptoms as severe as carpal tunnel syndrome.

19 34. In contrast to that twisting and/or clamping action (required by  
20 Defendants’ and third-party prior art poles that had been around for decades),  
21 Plaintiff’s ‘852 Patent inventions provide an easy-to-use “push button” detent  
22 engagement between the pole’s tubes. Plaintiff’s “push button” or “lever lock”  
23 detent pole inventions allow users to readily adjust and select the pole length  
24 simply by pressing a button or lever, rather than the prior art approach of twisting  
25 and untwisting the tubes and/or an external nut, and/or disengaging/engaging a  
26 clamp. In addition, Plaintiff’s ‘852 Patent inventions provide a positive  
27 engagement at a selected length, so that a user does not have to keep the tubes  
28

1 “torqued” during use in order to avoid the tubes disengaging from each other.

2 35. Below are examples of Plaintiff’s ‘852 inventions, as shown in Figures  
 3 1, 2b, and 2c from Plaintiff’s ‘852 patent. Fig. 1 shows an overall view, and  
 4 Fig. 2b shows details of the ‘852 patent length adjustment inventions shown in Fig.  
 5 1. Fig. 2c shows one of the many alternatives ways to practice those inventions  
 6 (using a lever instead of a button 11 for the length adjustment):

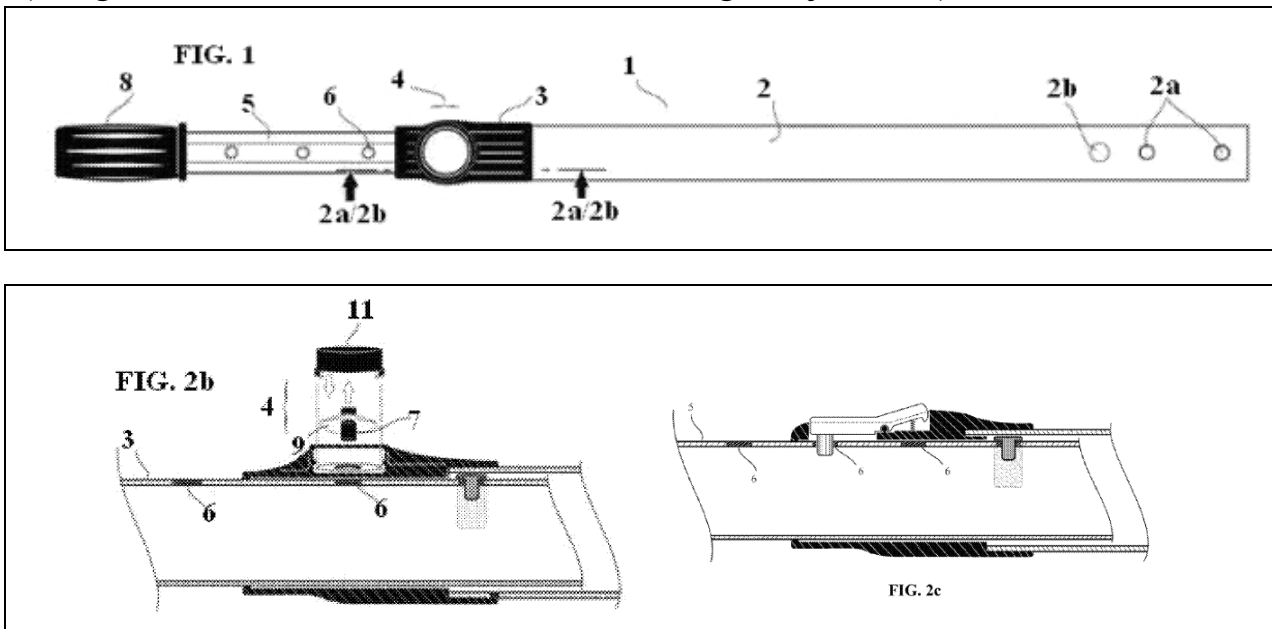

17

18 36. In the examples shown above, the user typically attaches a cleaning net  
 19 or brush or similar tool to one end of an outermost tube (such as via holes 2a at the  
 20 right end as shown in Fig. 1). The user can adjust the pole’s length (at any time,  
 21 and at multiple times during a cleaning), by using a button/lever assembly 4 to  
 22 engage a detent pin into a selected hole 6 along the inner tube’s length. The user  
 23 can grip and manipulate the pole 1 to do the cleaning, including by using a grip 8  
 24 on the opposite end of the pole (on the left end, as shown above) from the cleaning  
 25 tool.

26 37. The user can adjust the pole’s length without having to twist or  
 27 open/close clamps or nuts. Instead, the user just presses and releases a button or  
 28 lever (such as indicated at 4 and/or in Fig. 2c above). That simple action moves a

1 detent pin in and out of engagement with a selected hole 6 along the length of the  
2 inner tube 5. Once engaged in a selected hole 6, the pin keeps the pole set at that  
3 selected length (meaning that the tubes are “locked” together, and do not  
4 “telescope” to a longer or shorter length). When the user wants to adjust the pole  
5 to a different length, the user again presses the button/lever 4 to disengage the pin  
6 from the hole 6, and the user then can slide the tubes in or out of each other to a  
7 desired new length, where the pin will engage a different hole 6. Preferably a  
8 spring in the collar 3 urges the pin into engagement with the selected hole, and the  
9 user “overcomes” that spring urging by pressing on the button/lever to disengage  
10 the pin from the hole and permit length adjustment of the pole.

11 38. Thus, although an untrained observer might consider the technology in  
12 Plaintiff’s pole patents to be rather simple (after all, the patents deal with  
13 telescoping swimming pool poles), Plaintiff’s patented features are in fact such  
14 dramatic advances that Defendant Jim Conrad gasped when he saw them (as  
15 mentioned above), and Defendants and three other companies have copied  
16 Plaintiff’s now-patented inventions. The tremendous advantages in Plaintiff’s  
17 inventions are at least part of why Defendants copied and have been unwilling to  
18 stop infringing.

19 **DEFENDANTS HAVE ADMITTED SEVERAL POINTS, INCLUDING**  
20 **THAT THEY INFRINGE PLAINTIFF’S ‘852 INVENTIONS**

21 39. Resh realleges and incorporates by reference the allegations set forth in  
22 paragraphs 1-38.

23 40. This section of facts may be unique in patent disputes and patent  
24 lawsuits. Defendants already have (presumably inadvertently) made a number of  
25 admissions, all of which are against their own interests in this lawsuit. These  
26 admissions include at least the ones set forth below.

1                    **Defendants Have Admitted That They Infringe Plaintiff's '852 Patent**

2                    41. By Defendants' own filings in the U.S. Patent Office, Defendants have  
3 effectively admitted that they infringe Plaintiff's '852 Patent.

4                    42. As mentioned above and as alleged in greater detail below, Plaintiff sued  
5 Defendants in 2018 and forced Defendants to change Defendants' then-existing  
6 pole design that infringed Plaintiff's '458 Patent (another of Plaintiff's three pole  
7 patents, that the U.S. Patent Office had issued to Plaintiff in late 2017). More than  
8 18 months later (long after Plaintiff's 2018 lawsuit had been resolved), Plaintiff  
9 discovered that the lawsuit not only had forced Defendants to stop infringing  
10 Plaintiff's '458 Patent (by revising Defendants' pole design), but Plaintiff's 2018  
11 lawsuit also had prompted Defendants to secretly<sup>5</sup> file their own pole patent  
12 application, directed to Defendants' slightly revised copycat pole. On information  
13 and belief, Defendants mistakenly hoped that, if they succeeded in obtaining their  
14 own patent, they might use it as a "shield" against any further patents that Plaintiff  
15 might eventually obtain (such as Plaintiff's '852 Patent in this lawsuit). As the  
16 Court is aware, Defendants' "hope" in that regard is incorrect as a matter of law –  
17 the existence of any patent Defendants obtain from a later filing does not prevent  
18 that "later-patented" product from infringing Plaintiff's earlier-filed patent.

19                    43. Regardless of why Defendants filed that 2018 patent application in  
20 response to Plaintiff's lawsuit, Defendants' patent application constitutes an  
21 admission that Defendants' products infringe Plaintiff's '852 Patent.

22                    44. For some reason, when Defendants filed their 2018 patent application,  
23 they copied Plaintiff's now-issued Claim 21 as a "Claim 1" in Defendants'  
24 application. They also swore under penalty of perjury that Defendants' copy (of

25 \_\_\_\_\_  
26 <sup>5</sup> Defendants filed their secret patent application just weeks after Plaintiff  
27 served the 2018 lawsuit on Defendants. Defendants made their filing secretly (that  
28 is, without advising Plaintiff), and Plaintiff only became aware of Defendants'  
application more than a year later.

1 Plaintiff’s Claim 21) describes Defendants’ infringing pole products!

2 45. In this Complaint, Plaintiff includes several illustrations to make clear  
 3 that Defendants copied Plaintiff’s Claim 21. For example, below is a **table**  
 4 **highlighting the ONLY words that Defendants did NOT copy when they filed**  
 5 **under oath their own “Claim 1,” defining Defendants’ allegedly “new” pole**  
 6 **products:**

<b><u>Plaintiff RESH’s ‘852 Patent Claim 21</u></b> (highlighting the ONLY words Defendants did NOT Copy to Define Defendants’ OWN Pole Products)	
10	1. An <b>improved telepole</b> device, comprising:
11	an outer tube <b>element</b> having first and second ends,
12	said first end of the outer tube <b>element</b> having a collar <b>element associated</b>
13	<b>therewith, said collar element containing a</b> detent <b>means</b> ;
14	<b>an</b> inner tube <b>element</b> having first and second ends, said second end of the
15	outer tube having attachment means for removably attaching a tool;
16	<b>said</b> second end of said inner tube <b>element being</b> received in <b>the first end of</b>
17	the outer tube through an opening in said collar <b>element</b> ;
18	<b>wherein</b> said inner tube element is configured to readily slide within said outer
19	tube element to a selected position along the length of the outer tube, <b>and</b>
20	<b>wherein said</b> detent <b>means is configured to</b> temporarily lock the inner tube in
21	that selected position within the outer tube.

20 46. Said another way, there are only 131 total words in Plaintiff’s issued  
 21 Claim 21 (shown above). Defendants copied 100 of those words **virtually**  
 22 **verbatim!** The table below helps to further confirm Defendants’ copying and  
 23 resulting admission – that Defendants’ 2018 “revised” poles infringe Plaintiff’s  
 24 ‘852 Patent Claim 21. In the left column below is (again) Plaintiff’s issued ‘852  
 25 Patent Claim 21. In the right column is Defendants’ copied version of that claim.  
 26 Corresponding language between the two columns is shown in colored  
 27  
 28



1 highlighting<sup>6</sup> – again, totaling 100 words copied (of 131 total words):

<b>Plaintiff RESH’s ‘852 Patent Claim 21</b>	<b>Defendants’ Claim 1</b> <i>(Filed by Defendants in 2018)</i> <sup>7</sup>
1. An improved telepole device, comprising:	1. An apparatus for cleaning swimming pools, cement finishing tools, ceiling wire applications, and the like, comprising:
an outer tube element having first and second ends,	an outer tube having a first end and a second end,
said first end of the outer tube element having a collar element associated therewith, said collar element containing a detent means;	said first end of the outer tube having a collar housing and angled detent,
an inner tube element having first and second ends, said second end of the outer tube having attachment means for removably attaching a tool;	said second end of said outer tube having means for attaching a tool; a dodecagon shaped inner tube having a first end and a second end,

23 \_\_\_\_\_  
 24 <sup>6</sup> Defendants’ copying was so verbatim that just one passage that Defendants  
 25 copied is even slightly “out of order” with the rest of Defendants’ copying. In this  
 26 table, Plaintiff shows that copied (but out of sequence) passage in blue  
 27 highlighting.

28 <sup>7</sup> As discussed elsewhere herein, the Patent Office eventually rejected this  
 claim and all of Defendants’ claims, based on a 2018 publication of Plaintiff’s  
 inventions. The Patent Office’s rejection is yet further confirmation of  
 Defendants’ copying and/or infringement of Plaintiff’s ‘852 Patent rights.

<u>Plaintiff RESH’s ‘852 Patent Claim 21</u>	<u>Defendants’ Claim 1</u> <i>(Filed by Defendants in 2018)</i> <sup>7</sup>
<p>said <b>second end of said inner tube</b> element being <b>received in the first end of the outer tube through an opening in said collar</b> element;</p> <p>wherein <b>said inner tube element is configured to readily slide within said outer tube element to a selected position along the length of the outer tube</b>, and wherein <b>said detent means is configured to temporarily lock the inner tube in that selected position within the outer tube.</b></p>	<p>and includes a detachable grooved grip for grasping and positioning the apparatus; said <b>second end of said inner tube</b> is adapted and configured to be received within <b>said outer tube within an aperture in said collar housing</b>; the inner tube is shaped to slide within <b>said outer tube to a selected position in relation to said outer tube</b>, allowing for <b>said angled detent to position and secure the inner tube within the outer tube</b>; and a plurality of apertures aligned on the inner tube, so that the angled <b>detent</b>, which includes a <b>locking means</b>, may be operably engaged with one of <b>said apertures, to secure and position the inner tube at a selected position within said outer tube.</b></p>

47. In case it is helpful, below are the 31 “filler” (non-substantive words) that Defendants did not copy, in a layout similar to the first table above:

<u>Plaintiff RESH’s ‘852 Patent Claim 21</u> (showing ONLY the words Defendants did NOT Copy)
1. <i>improved telepole:</i>
<i>element,</i>
<i>element element associated therewith, said collar element containing a means;</i>
<i>an element;</i>
<i>said element being the first end of element;</i>
<i>wherein and wherein said means is configured to.</i>

48. None of those words in the table above (that Defendants “omitted” in Defendants’ copying of Plaintiff’s Claim 21) are “elements” of the claim. Instead, those words are transitional/non-substantive claim language. In other words, of the

1 substantive elements in Plaintiff’s ‘852 Patent Claim 21, Defendants have  
2 admitted that their products include every element. Defendants therefore have  
3 admitted that their products infringe at least Plaintiff’s ‘852 Patent Claim 21.

4 49. Based on the virtual identity of Defendants’ copying shown above,  
5 Plaintiff alleges that Defendants copied Plaintiff’s claim (with the slight  
6 differences shown above) and included that copied claim in Defendants’ 2018  
7 patent application.

8 50. On information and belief, and as further discussed below, Defendants  
9 were able to copy that language because, at the time Defendants filed their 2018  
10 patent application, Defendants had access to Plaintiff’s eventual Claim 21  
11 language. Defendants (themselves or via any patent attorney or patent agent who  
12 assisted Defendants’ patent filing) had a copy of the Patent Office’s 2013  
13 publication and/or the Patent Office’s January 2018 publication of Plaintiff’s  
14 patent application.

15 51. Defendants’ 2018 patent application (including the claim in the right-  
16 hand column above) accurately described at least some of Defendants’ pole  
17 products at that time that Defendants filed it.

18 52. Defendants’ 2018 patent application (including the claim in the right-  
19 hand column above) continues to accurately describe at least some of Defendants’  
20 pole products that Defendants continue to make and sell today, including ones that  
21 Plaintiff is accusing herein of infringing Plaintiff’s ‘852 Patent (including without  
22 limitation Defendants’ two-piece SnapLite<sup>8</sup> poles described herein, and any  
23 corresponding private-labeled poles).

24 53. Defendants filed their 2018 patent application (including the claim in the  
25 right-hand column above) with a declaration under penalty of perjury. To make

26 \_\_\_\_\_  
27 <sup>8</sup> Defendants’ have named their infringing copies of Plaintiff’s ‘852 Patent  
28 pole inventions Defendants “SnapLite” poles.

1 the record even more complete in that regard (and to reduce the need to litigate it  
2 in this lawsuit), below are true and correct copies of U.S. Patent Office records,  
3 including (a) portions of Defendant James Conrad’s sworn Declaration (dated  
4 March 7, 2018), as Defendants filed it with the Patent Office, and (b) Defendants’  
5 Claim 1 as it appeared on pages 23-24 of Defendants’ application (the same Claim  
6 1 shown in the right-hand column of the above table). In signing this Declaration,  
7 Defendant James Conrad confirmed under 18 USC 1001 (penalty of perjury) that  
8 his application includes the “invention” defined in the right-hand column of the  
9 table above:

10  
11  
12  
13  
14  
15  
16  
17  
18  
19  
20  
21  
22  
23  
24  
25  
26  
27  
28

Attorney's Docket No. CONRAD-1X

PATENT

**COMBINED DECLARATION AND POWER OF ATTORNEY**

*(ORIGINAL, DESIGN, NATIONAL STAGE OF PCT, SUPPLEMENTAL, DIVISIONAL, CONTINUATION OR C-I-P)*

As a below named inventor, I hereby declare that:

**TYPE OF DECLARATION**

This declaration is of the following type: (check one applicable item below)

- original
- design
- supplemental

*NOTE: If the declaration is for an International Application being filed as a divisional, continuation or continuation-in-part application, do not check next item; check appropriate one of last three items.*

- national stage of PCT

*NOTE: If one of the following 3 items apply, then complete and also attach ADDED PAGES FOR DIVISIONAL, CONTINUATION OR C-I-P.*

- divisional
- continuation
- continuation-in-part (C-I-P)

**INVENTORSHIP IDENTIFICATION**

My residence, post office address and citizenship are as stated below next to my name. I believe I am the original, first and sole inventor (if only one name is listed below) or an original, first and joint inventor (if plural names are listed below ) of the subject matter which is claimed and for which a patent is sought on the invention entitled:

**TITLE OF INVENTION**

**TELESCOPIC POLE FOR SWIMMING POOL TOOLS**

**DECLARATION**

As below named inventor: I herby declare that:

The above-identified application was made or authorized to be made by me.

I believe that I am the original inventor or an original joint inventor of a claimed invention in the application.

I hereby acknowledge that any willful false statement made in this declaration is punishable under 18 U.S.C. 1001 by fine or imprisonment of not more than five (5) years, or both.

I further hereby declare that all statements made herein of my own knowledge are true and that all statements made on information and belief are believed to be true; and further that these statements were made with the knowledge that willful false statements and the like so made are punishable by fine or imprisonment, or both, under Section 1001 of Title 18 of the United States Code, and that such willful false statements may jeopardize the validity of the application or any patent issued thereon.

(Declaration and Power of Attorney [1-1]—page 4 of 6)

**SIGNATURE(S)**

NOTE: Carefully indicate the family (or last) name as it should appear on the filing receipt and all other documents.

Full name of sole or first inventor

James R. Conrad  
(GIVEN NAME) (MIDDLE INITIAL OR NAME) FAMILY (OR LAST NAME)

Inventor's signature 

Date 3-7-18 Country of Citizenship U.S.

Residence 1518 Moffett Street #E, Salinas, CA. 93905

Post Office Address Same As Above

Claims

What is claimed is:

5

1. An apparatus for cleaning swimming pools, cement finishing tools, ceiling wire applications, and the like, comprising:

10

an outer tube having a first end and a second end, said first end of the outer tube having a collar housing and angled detent, said second end of said outer tube having means for attaching a tool;

15

a dodecagon shaped inner tube having a first end and a second end, and includes a detachable grooved grip for grasping and positioning the apparatus; said second end of said inner tube is adapted and configured to be received within said outer tube within an aperture in said collar housing; the inner tube is shaped to slide within said outer tube to a selected position in relation to said outer tube, allowing for said angled detent to position and secure the inner tube within the outer tube; and

25

a plurality of apertures aligned on the inner tube, so that the angled detent, which includes a locking means, may be operably engaged with one of said apertures, to secure and position the inner tube at a selected position within said outer tube.

54. In summary, based on the virtual 100% copying of Plaintiff's Claim 21 above, it is beyond dispute that Defendants had a copy of Plaintiff's pending

1  
2  
3  
4  
5  
6  
7  
8  
9  
10  
11  
12  
13  
14  
15  
16  
17  
18  
19  
20  
21  
22  
23  
24  
25  
26  
27  
28

1 application by on or around March 7, 2018, when they filed Defendants' own  
2 patent application. Possibly more importantly, however, and again based on  
3 Defendants' own sworn filings in the U.S. Patent Office, Defendants have  
4 effectively **admitted** that they infringe Plaintiff's '852 Patent. Plaintiff therefore  
5 hopes and expects that this lawsuit therefore will not require litigation of that issue,  
6 and looks forward to Defendants at least admitting that point.

7 55. As further discussed below, although **Defendants copied directly** from  
8 Plaintiff's 2013 published claim, Defendants violated their duty to the Patent  
9 Office regarding that copying, by not advising the Patent Office Examiner of the  
10 existence Plaintiff's 2013 published claim. As the Court may realize, all patent  
11 applicants have a duty to disclose to the Patent Office (and to the specific  
12 Examiner assigned to handle their patent application) information that may be  
13 material to whether the applicants' claims are patentable. A claim from which  
14 Defendants copied 100 of 131 words verbatim certainly meets that definition (of  
15 being "material"), and Defendants chose to not disclose their copying of Plaintiff's  
16 claim (or the source from which Defendants copied).

17 56. Among other things, Defendants have unclean hands, and this Court  
18 should enter appropriate orders to Defendants' prejudice, based on those unclean  
19 hands.

20 **Defendants Have Admitted That Their Infringing Products Are Quickly**  
21 **Becoming "MANY PEOPLE'S FAVORITE" Pole**

22 57. In addition to admitting that they are infringing Plaintiff's '852 Patent,  
23 Defendants have admitted that their infringing products are **quickly becoming the**  
24 **favorite** poles of many of Defendants' customers. On or about May 2020, just two  
25 years after Plaintiff forced Defendants to revise Defendants' infringing poles,  
26 Defendants posted a YouTube video about those revised poles. In that video,  
27 Defendant Barrett Conrad admits that Defendants' infringing SnapLite poles are  
28



1 “quickly becoming many people’s favorite.” Below is a screenshot from  
2 Defendants’ video admission (from  
3 [https://www.youtube.com/watch?v=5ELd\\_\\_3PpDI](https://www.youtube.com/watch?v=5ELd__3PpDI), at the 0:35 mark):

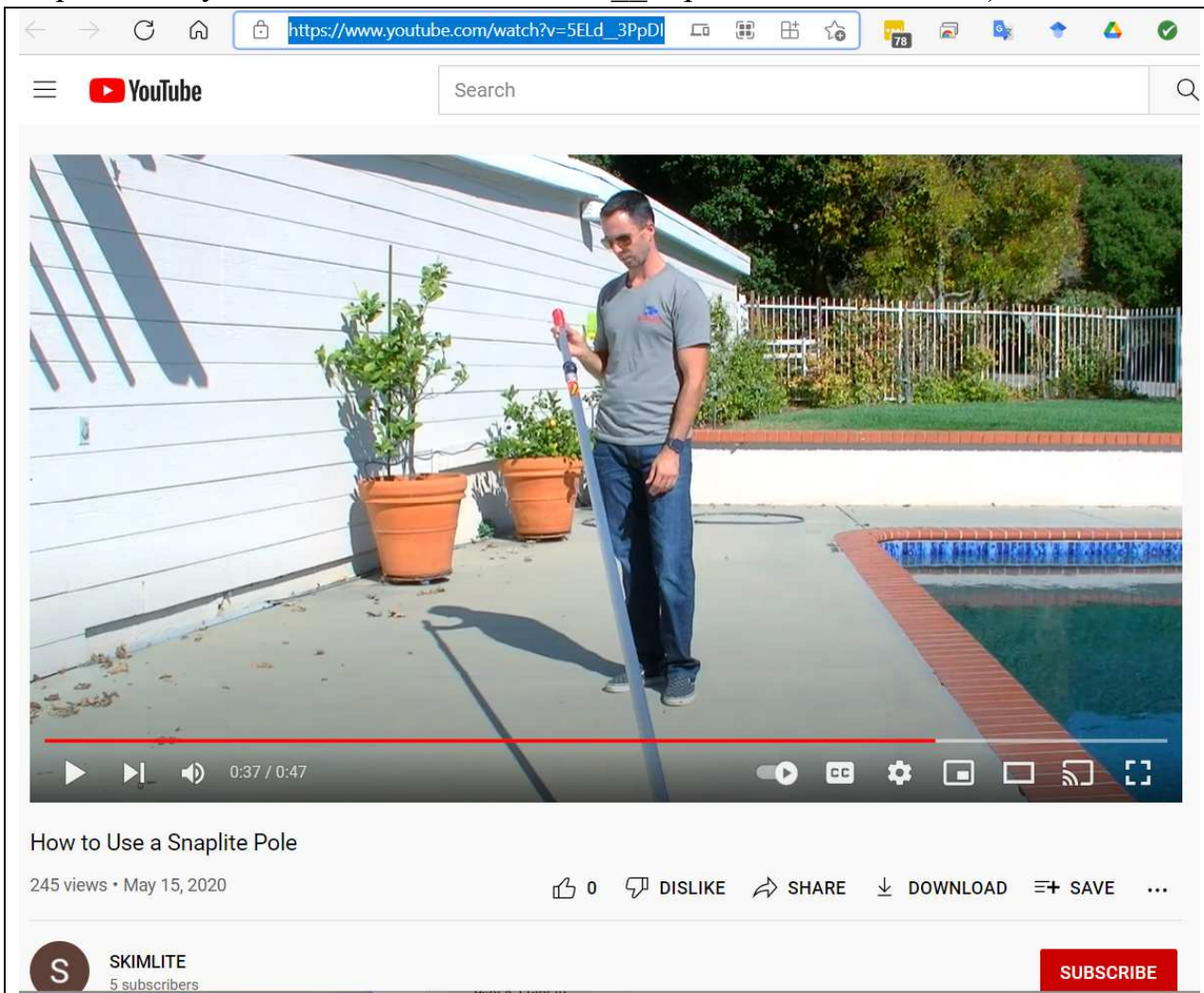

4  
5  
6  
7  
8  
9  
10  
11  
12  
13  
14  
15  
16  
17  
18  
19  
20  
21  
22  
23  
24  
25  
26  
27  
28

58. On a related point, a YouTube post at <https://www.youtube.com/watch?v=u5hTKelagiE> says (beginning at the 3:10 mark) that the user (a pool man) “find[s] the [infringing Snaplite] buttons easier to use on the SnapLite pole versus twisting and unlocking the [Skimlite prior art Dually pole] sections.”

**DEFENDANTS' PRODUCTS INFRINGE PLAINTIFF'S '852 INVENTIONS**

59. As discussed herein, Defendants' poles infringe Plaintiff's '852 patent claims. In addition to other discussion herein, this infringement is illustrated generally in a table attached hereto as Exhibit C. That table illustrates the infringement of both Defendants' two-tube and three-tube poles. That table is preliminary and is not intended to be a comprehensive and/or final litigation claims chart, but instead is only a broad and exemplary overview of Defendants' infringement. Among other things, and by way of example, that table preliminarily analyzes the independent claims of Plaintiff's '852 Patent (Claims 1, 2, 20, and 21), but does not include any analysis of Plaintiff's dependent claims that Defendants may be infringing. A further example is that Plaintiff has not yet been able to comprehensively confirm the scope of Defendants' product line, private-labeling, or other potentially infringing products, and the table only illustrates infringement of two models of Defendants' infringing poles.

60. Defendants make, use, sell, offer for sell, and/or import into the U.S. products that infringe Plaintiff's '852 patent. These products include, but are not necessarily limited to, Defendants' "SnapLite" poles discussed and shown herein.

**DEFENDANTS COPIED PLAINTIFF'S '852 INVENTIONS**

61. Resh realleges and incorporates by reference the allegations set forth in paragraphs 1-59.

62. In addition to Defendants' own admissions (discussed above) and the preliminary claim charts of Exhibit C, there is substantial other evidence that Defendants copied and are infringing Plaintiff's '852 Patent rights. Separate from issues of infringement, the Defendants' copying of Plaintiff's '852 Patent inventions is clear from a variety of evidence, including the examples discussed herein.

1           63. A chronology of Defendants’ swimming pool pole products is part of  
2 that further evidence. That chronology starts many decades ago, before Plaintiff’s  
3 inventor Eric Resh was even born. Defendants promote Skimlite as having created  
4 the very first telescoping swimming pool pole, in approximately 1954. Since that  
5 time, and without interruption, Defendants have been making telescoping  
6 swimming pool poles. In other words, Defendants have been making telescoping  
7 swimming pool poles for nearly 70 years. They have had all of those decades to  
8 create and refine their pole products. On information and belief, during those  
9 many decades before they saw Plaintiff’s ‘852 Patent inventions, Defendants  
10 revised and added to their line of pole products.

11           64. Plaintiff Resh first showed Plaintiff’s ‘852 Patent inventions publicly at  
12 an industry trade show in 2012. At that time, Defendants had been making  
13 telescoping pool poles for almost 60 years.

14           65. On information and belief, during all of those decades of making  
15 telescoping pool poles (prior to 2012), Defendants had never previously made or  
16 sold any “button/lever/detent” style telescoping swimming pool pole. Instead, all  
17 of the telescoping swimming pool poles Defendants had made and/or sold used  
18 twisting or clamping to lock the pole at a selected length.

19           66. At that 2012 trade show, both Plaintiff and Defendants had booths to  
20 display and promote their respective products. By coincidence (and as discussed in  
21 further detail in Exhibit B), near the start of that trade show Defendant Jim Conrad  
22 walked up to Plaintiff’s booth and picked up Plaintiff’s prototype pole. Mr.  
23 Conrad was so startled by Plaintiff’s pole that Mr. Conrad immediately gasped.

24           67. After seeing Plaintiff’s new pool pole inventions in 2012, Defendants  
25 began copying Plaintiff’s swimming pool pole inventions.

26           68. Defendants did not begin making and selling their SnapLite telescoping  
27 poles until after seeing Plaintiff’s ‘852 button/detent/lever lock pole inventions.  
28

69. It may also be helpful to illustrate Defendants’ copying and infringement by including a more direct visual contrast of (a) Defendants’ old-style telescoping swimming pools poles (that use the **twisting or clamping** approaches mentioned above), with (b) Defendants’ copies of Plaintiff’s ‘852 Patent pole inventions. Defendants’ own website includes photographs of both of those types of Defendants’ poles. Below is the same part of Defendants’ website (at <https://skimlite.com/>) as shown above. As with the copy above, this copy includes some very slight editing, to enhance and clarify the comparison and contrast between (a) the top group of five photographs that show Defendants’ poles using Defendants’ **decades-old** twisting/clamping length adjustments, and (b) the sixth photograph (enlarged below the other five), that shows some of Defendants’ infringing copies of Plaintiff’s ‘852 Patent pole inventions (which, again, Defendants have named their “SnapLite” poles):



**Defendants' New Infringing "SnapLite" Poles**

70. The above screenshots from Defendants' website have been edited as follows:

- the upper image shows some of Defendants' prior art twisting/clamping pole models, but also has a white square added in the upper right quadrant of the screenshot (the material that normally appears in that square has been cut and pasted and slightly enlarged, as the lower image);<sup>9</sup> and
- the lower image is that cut/pasted white block area (from the upper image). In the lower image, Defendants' infringing push button/lever features are highlighted with yellow arrows.<sup>10</sup>

71. As noted above, the upper image above shows some of Defendants'

<sup>9</sup> For extra clarity, Plaintiff notes that Defendants' actual website does **not** include the "white square" in the upper right quadrant. Cutting and pasting that "white square block" is intended to permit a focused review and discussion of only Defendants' **prior art style** pool poles, and an even more vivid comparison against Defendants' copying of Plaintiff's pole inventions.

<sup>10</sup> The yellow arrows in the lower image were added for ease of review, and are not in Defendants' actual website display.

1 many twisting/clamping **prior art style** swimming pool poles. **None** of  
2 Defendants' swimming pool poles shown in that upper image have a  
3 detent/button/lever lock length adjustment. Instead, in ALL of those poles  
4 Defendants use twisting and/or clamping or other similar decades-old technology,  
5 to keep the swimming pool pole set at a selected length. Until Defendants saw  
6 Plaintiff's '852 Patent pole inventions (around 2012), during all those **decades**  
7 of making telescoping swimming pool poles, the **only** telescoping swimming pool  
8 poles that Defendants made and sold used that **prior art twisting or clamping**  
9 technology.

10 72. Defendants' copying of Plaintiff's '852 Patent push button/lever lock  
11 inventions is easy to see visually, simply by reviewing that lower image with the  
12 yellow arrows. The yellow arrows in that cut/pasted square point to the infringing  
13 push-button lever lock technology (that Defendants copied from Plaintiff's '852  
14 Patent inventions). Instead of continuing to use Defendants' old **prior art twisting**  
15 **or clamping style** (shown in the five upper screenshot images), Defendants copied  
16 Plaintiff's inventions (as shown by the yellow arrows in the lower image).

73. As mentioned above, the lower image shows some of Defendants’ infringing “SnapLite” series of poles (specifically the “6317” and “6016” models of Defendants’ SnapLite poles). Upon information and belief, Defendants’ infringing models include more than just those two models shown in the screenshot above. Upon information and belief, Defendants’ infringing products include at least Defendants’ lighter-weight “homeowner” models 1012 and 1016, and Defendants’ “professional” models 6012, 6016, 6317, and 6323, as well as infringing poles Defendants are private-labeling for third parties (such as First Choice poles discussed herein). Below are screenshots of the gripping ends of some of Defendants’ other models:



1  
2  
3  
4  
5  
6  
7  
8  
9  
10  
11  
12  
13  
14  
15  
16  
17  
18  
19  
20  
21  
22  
23  
24  
25  
26  
27  
28



Infringing Model 6012



Infringing Model 6016



Infringing Model 6317



74. Below are further screenshots of Defendants’ infringing products, taken from Defendants’ website ([www.skimlite.com](http://www.skimlite.com)). In the first screenshot, some highlighting is added to distinguish Defendants’ infringing products (Models 1012 and 1016) from other telescoping pool poles (the rest of the poles in the screenshot) that Defendants sell:

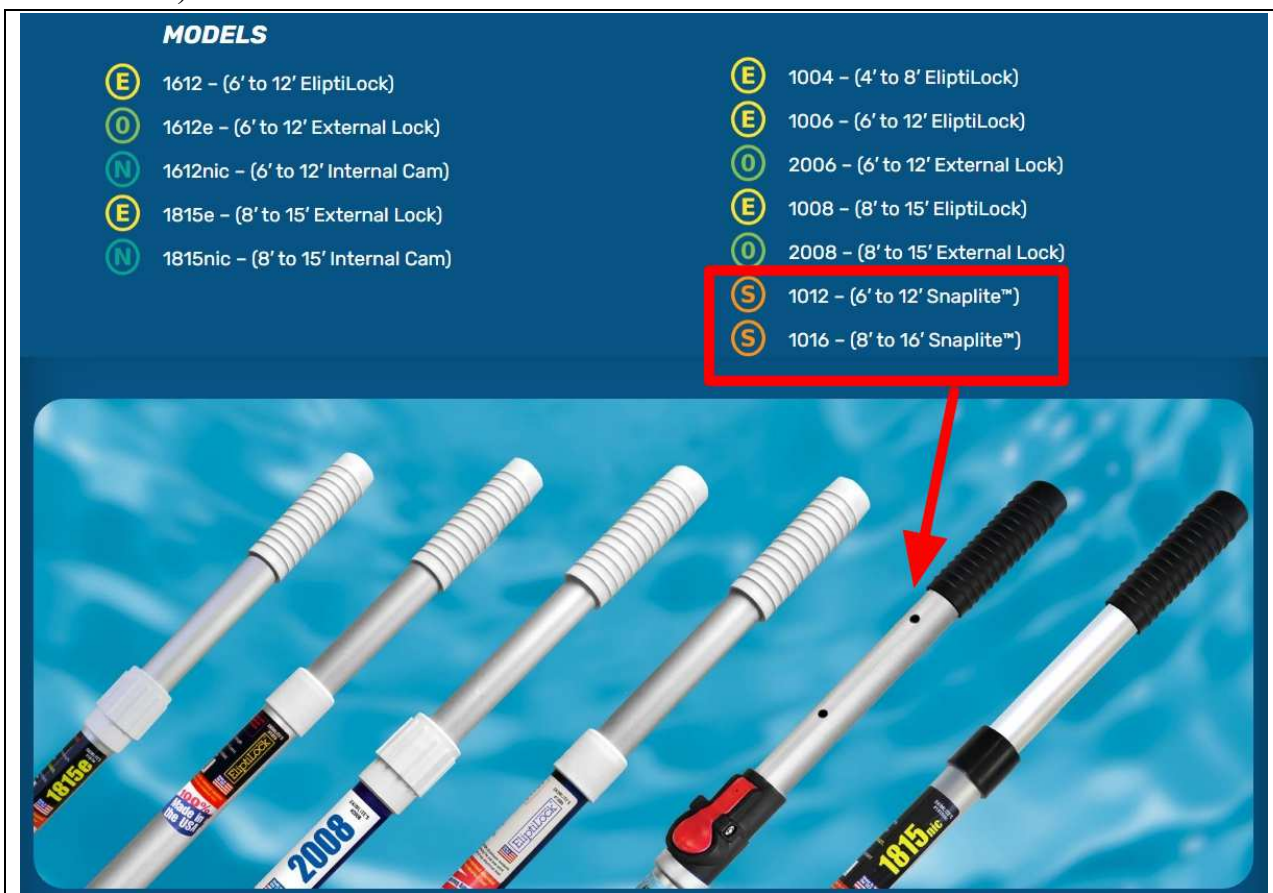

1  
2  
3  
4  
5  
6  
7  
8  
9  
10  
11  
12  
13  
14  
15  
16  
17  
18  
19  
20  
21  
22  
23  
24  
25  
26  
27  
28

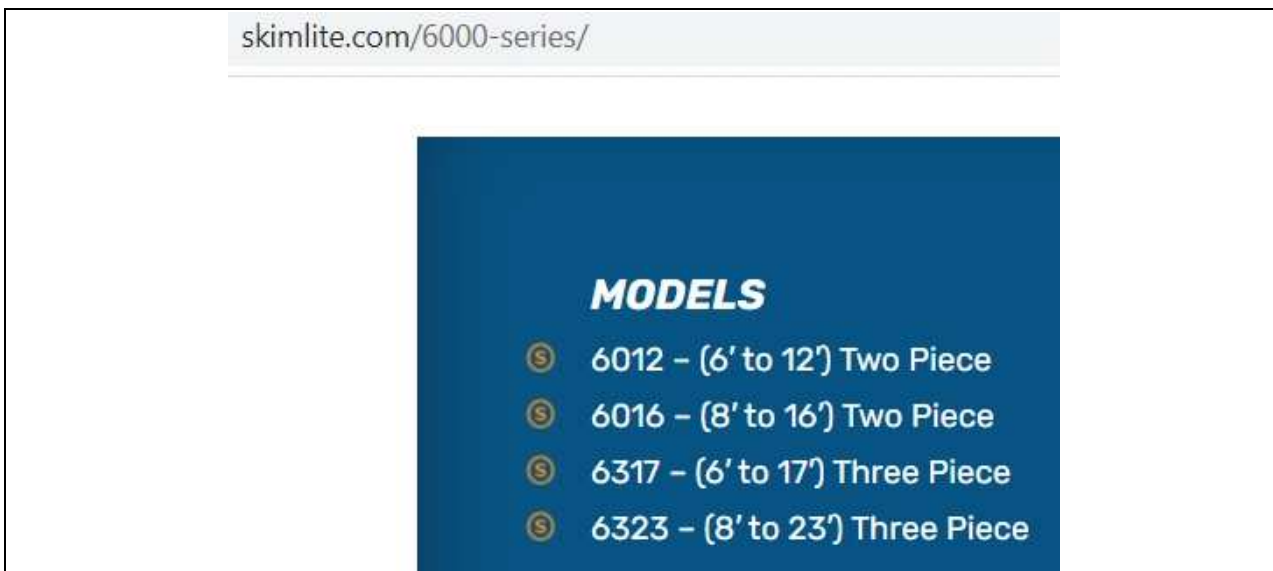
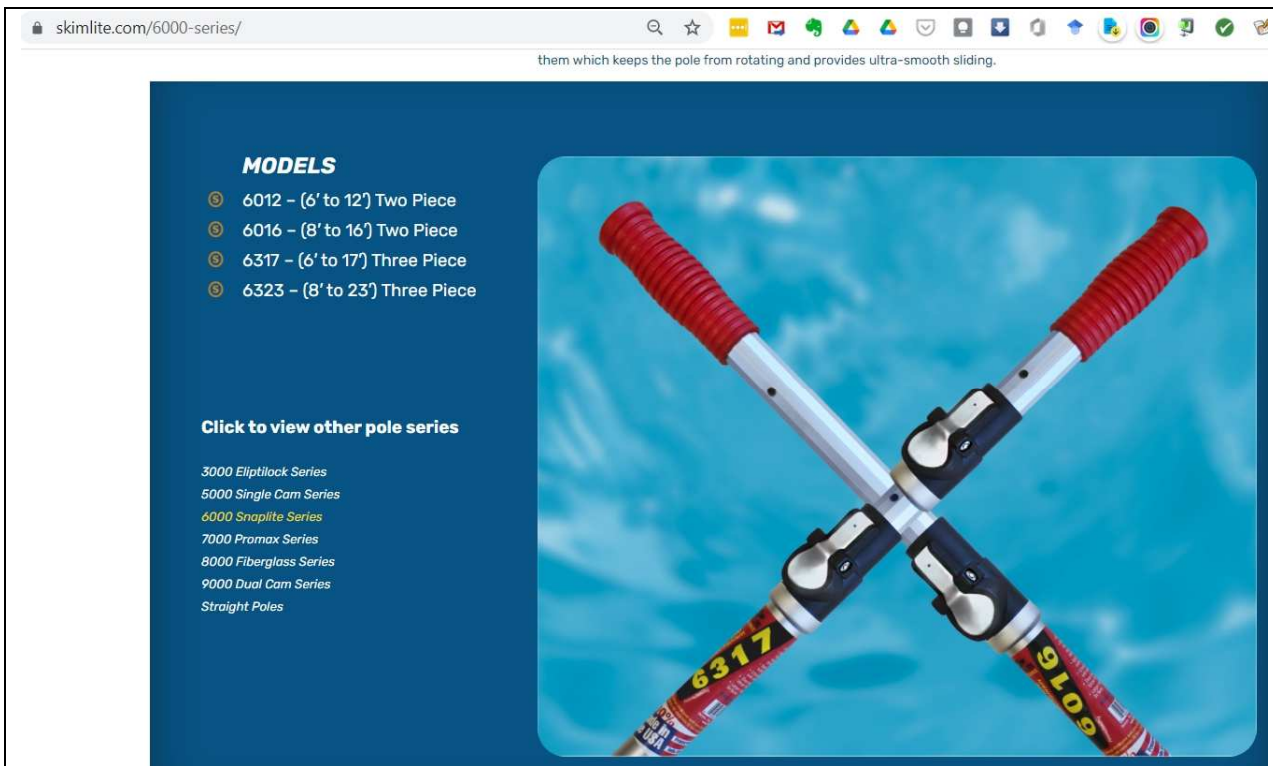

75. In addition, on information and belief and as mentioned above, Defendants have begun private-label manufacturing of infringing poles for third parties. Those include, for example, a “First Choice” brand of poles, which Defendants have private-labeled and which are sold by a major industry distributor named PEP. Below is a true and correct screenshot, with red highlighting added,

1 of the infringing First Choice brand poles with push-button/lever lock features  
2 (from <https://firstchoicepool.com/product/fch303318/>):

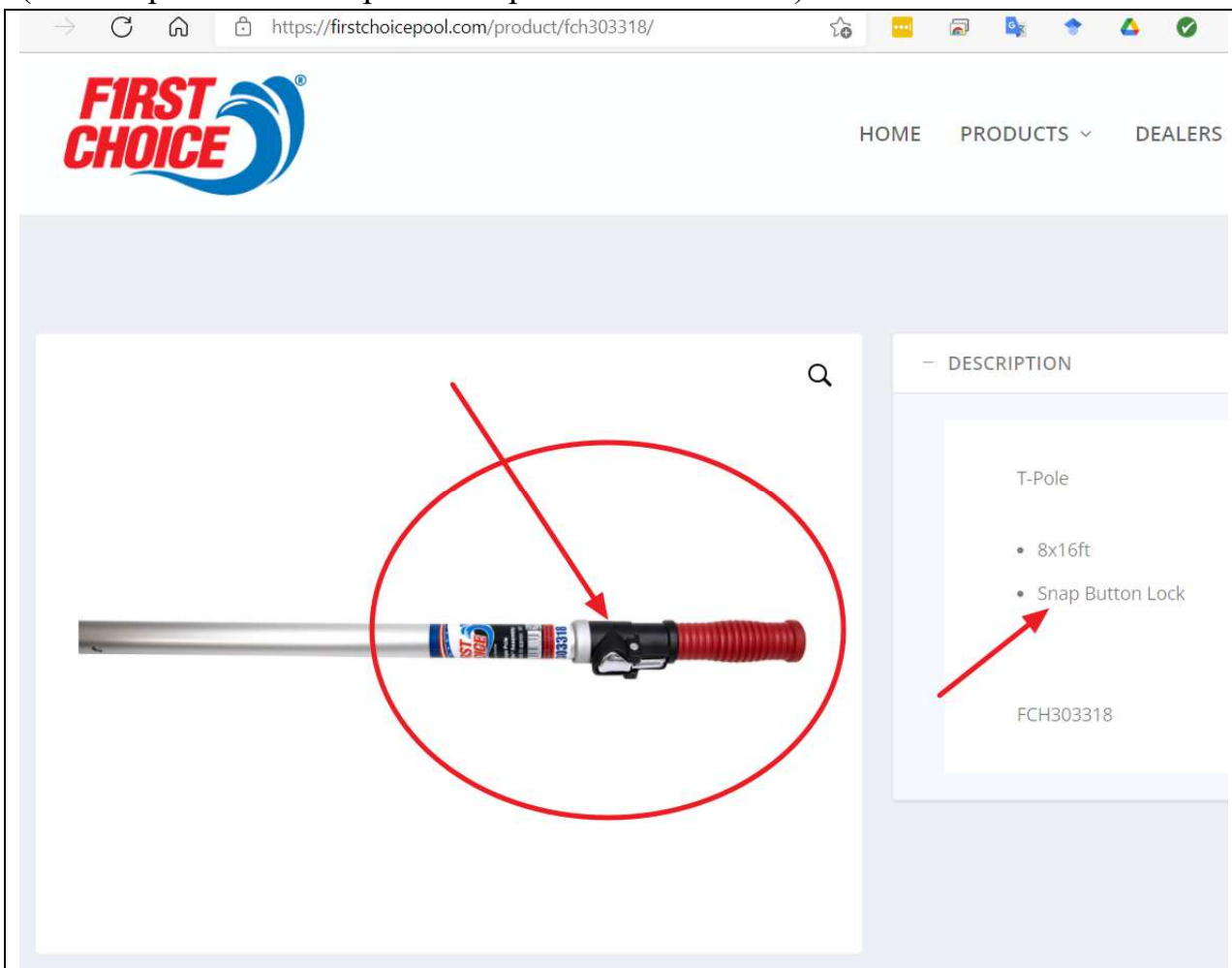

25 76. Upon information and belief, Defendants' infringing SkimLite (and/or  
26 private-labeled) poles generally can be divided into two categories: (1) poles  
27 fabricated from two telescoping tubes; and (2) poles fabricated from three  
28

1 telescoping tubes. Both versions incorporate and infringe the ‘852 Patent’s  
2 inventions. Of the models listed above, Models 6317 and 6323 have three tubes  
3 (on information and belief, the Defendants’ use the underlined “3” in their model  
4 numbers 6317 and 6323 to indicate that the model uses 3 tubes). On information  
5 and belief, Defendants’ other SnapLite models use two tubes.

6 77. As mentioned above, Defendants’ call their new infringing poles  
7 “SnapLite” poles. That name choice by Defendants is further evidence confirming  
8 Defendants’ copying of Plaintiff’s ‘852 Patent push button/lever lock inventions.  
9 On information and belief, Defendants chose that name because those infringing  
10 poles use Plaintiff’s patented inventions to provide a “snap” engagement for  
11 adjusting the poles’ length (in contrast to continuing to use Defendants’ decades-  
12 old twisting/clamping engagement to set the length of the pole). Defendants’  
13 choice of “SnapLite” apparently is intended to evoke in customers’ minds that  
14 Plaintiff’s push-button technology is a “snap” to use, or that the push-button  
15 technology “snaps” into engagement at a desired pole length. In either case, it  
16 confirms that Defendants adopted Plaintiff’s inventions.

17 78. Other evidence shows that Defendants copied Plaintiff’s ‘852 Patent  
18 inventions. As mentioned above, approximately 10 years ago, in 2012, Plaintiff  
19 Resh first showed the ‘852 Patent inventions publicly, by bringing Plaintiff’s first  
20 prototype to an industry trade show at which both Plaintiff and Defendants had  
21 booths. By coincidence, one of the first people to see Plaintiff’s “first public  
22 disclosure” of those pole inventions was Defendant James Conrad. After  
23 Defendants saw Plaintiff’s ‘852 swimming pool pole inventions, Defendants  
24 (along with several other competitors) copied those inventions and began selling  
25 products that now are covered by Plaintiff’s ‘852 Patent. This copying (by  
26  
27  
28

1 Defendants and others) is discussed in further detail in Exhibit D.<sup>11</sup>

2 79. As discussed herein, Defendants' copying went even further than those  
3 other competitors. Unlike those other infringers, **Defendants** copied not just  
4 Plaintiff's push-button/lever lock feature, but also Plaintiff's water channel feature  
5 (for which the Patent Office awarded Plaintiff's first patent, in late 2017)<sup>12</sup> and  
6 Plaintiff's multiple attachment holes feature (for which the Patent Office awarded  
7 Plaintiff's second patent, in August 2021). Again, unlike those other copying  
8 infringers, Defendants apparently had no qualms about copying every aspect and  
9 feature of Plaintiff's pole inventions. As mentioned elsewhere, in early 2018  
10 (when Plaintiff became aware of Defendants' infringement of that 2017 patented  
11 feature and Defendants refused to stop infringing), Plaintiff sued and forced  
12 Defendants to stop infringing, and in late 2021, forced Defendants to stop  
13 infringing Plaintiff's second patent.

14 80. Some of the additional extensive evidence of Defendants' copying of  
15 Plaintiff's pole inventions is discussed here, as well as in further sections below,  
16 and much of this evidence is relevant to multiple issues in this lawsuit (including,  
17 for example, Defendants' willfulness and Defendants' liability for pre-issuance  
18 damages and other relief sought by Plaintiff). As noted above, some of that  
19 additional evidence of copying is provided by Defendants' own filings in the U.S.  
20 Patent Office itself.

21 81. As mentioned above, and more than one and a half years after Plaintiff's  
22

---

23 <sup>11</sup> As mentioned in Exhibit C, the other copiers of which Plaintiff is currently  
24 aware are companies named Oreq, ProTuff, and AquaEZ. Exhibit C is a true and  
25 correct copy of additional portions of Plaintiff's filings in the U.S. Patent Office  
26 that eventually led the Office to grant the '852 patent. Pages 9, 10, 137, 138, and  
27 139 are true and correct descriptions of Defendants' and third party copying of  
28 Plaintiff's '852 Patent inventions.

<sup>12</sup> The other infringers did not copy that feature, perhaps in acknowledgement  
that at least THAT feature was likely to be awarded patent protection by the Patent  
Office.

1 2018 lawsuit, Plaintiff discovered that Plaintiff’s 2018 lawsuit had not only  
2 prompted Defendants to stop infringing Plaintiff’s ‘458 Patent (by removing the  
3 infringing water channel), but also to secretly<sup>13</sup> file a patent application directed to  
4 Defendants’ “new” version of copycat pole (a version without any infringing water  
5 channel).<sup>14</sup> As mentioned above, the Patent Office eventually rejected all of  
6 Defendants’ claims based on Plaintiff’s inventions. The Patent Office’s rejection  
7 of Defendants’ claims is important to the issues in the present lawsuit for several  
8 reasons. Among other things, the Patent Office’s rejection is a further “objective  
9 third party” indication that Defendants’ patent application (directed to Defendants’  
10 “revised” products) shows that even Defendants’ “revisions” in 2018 continued  
11 copying Plaintiff’s inventions.

12 82. More specifically, in July 2019 the U.S. Patent Office rejected  
13 Defendants’ 2018 patent application, because Defendants’ device was so similar to  
14 Plaintiff’s earlier ‘852 Patent inventions. In that regard, below is a true and correct  
15 copy of relevant portions of the Patent Office’s February 2020 Notice of  
16 Abandonment communication to Defendants, rejecting Defendants’ patent  
17 application based on the similarity to (or copying of) Plaintiff’s earlier-filed patent  
18 applications/inventions:<sup>15</sup>

---

21  
22 <sup>13</sup> Defendants filed their secret patent application just weeks after Plaintiff  
23 served the 2018 lawsuit on Defendants. Defendants made their filing secretly (that  
24 is, without advising Plaintiff), and Plaintiff only became aware of Defendants’  
25 application more than a year and a half later, after the Patent Office published  
26 Defendants’ application in September 2019 (see below).

27 <sup>14</sup> As reflected in the various correspondence and Patent Office documents  
28 included herein, Defendants used a different attorney to file their patent application  
than they used to represent them in the 2018 lawsuit. Among other things, that  
may be a factor in why Defendants copied Plaintiff’s Claim 21 into Defendants’  
2018 patent application.

<sup>15</sup> See also page 139 of Exhibit C.



UNITED STATES PATENT AND TRADEMARK OFFICE

UNITED STATES DEPARTMENT OF COMMERCE  
 United States Patent and Trademark Office  
 Address: COMMISSIONER FOR PATENTS  
 P.O. Box 1450  
 Alexandria, Virginia 22313-1450  
 www.uspto.gov

APPLICATION NO.	FILING DATE	FIRST NAMED INVENTOR	ATTORNEY DOCKET NO.	CONFIRMATION NO.
15/932,534	03/12/2018	James R. Conrad	CONRAD-IX	2743
38030 JEFFREY HALL 212 CLINTON ST SANTA CRUZ, CA 95062	7590 07/30/2019		EXAMINER SULLIVAN, MATTHEW J	
			ART UNIT 3677	PAPER NUMBER
			MAIL DATE 07/30/2019	DELIVERY MODE PAPER

Please find below and/or attached an Office communication concerning this application or proceeding.

The time period for reply, if any, is set in the attached communication.

<b>Office Action Summary</b>	Application No. 15/932,534	Applicant(s) Conrad, James R.	
	Examiner MATTHEW J SULLIVAN	Art Unit 3677	AIA (FITF) Status Yes

*-- The MAILING DATE of this communication appears on the cover sheet with the correspondence address --*

**Period for Reply**  
 A SHORTENED STATUTORY PERIOD FOR REPLY IS SET TO EXPIRE 3 MONTHS FROM THE MAILING DATE OF THIS COMMUNICATION.  
 - Extensions of time may be available under the provisions of 37 CFR 1.136(a). In no event, however, may a reply be timely filed after SIX (6) MONTHS from the mailing date of this communication.  
 - If NO period for reply is specified above, the maximum statutory period will apply and will expire SIX (6) MONTHS from the mailing date of this communication.  
 - Failure to reply within the set or extended period for reply will, by statute, cause the application to become ABANDONED (35 U.S.C. § 133). Any reply received by the Office later than three months after the mailing date of this communication, even if timely filed, may reduce any earned patent term adjustment. See 37 CFR 1.704(b).

**Status**  
 1)  Responsive to communication(s) filed on 3/12/18.  
 A declaration(s)/affidavit(s) under 37 CFR 1.130(b) was/were filed on \_\_\_\_\_.  
 2a)  This action is FINAL. 2b)  This action is non-final.  
 3)  An election was made by the applicant in response to a restriction requirement set forth during the interview on \_\_\_\_\_; the restriction requirement and election have been incorporated into this action.  
 4)  Since this application is in condition for allowance except for formal matters, prosecution as to the merits is closed in accordance with the practice under *Ex parte Quayle*, 1935 C.D. 11, 453 O.G. 213.

**Disposition of Claims\***  
 5)  Claim(s) 1-19 is/are pending in the application.  
 5a) Of the above claim(s) \_\_\_\_\_ is/are withdrawn from consideration.  
 6)  Claim(s) \_\_\_\_\_ is/are allowed.  
 7)  Claim(s) 1-19 is/are rejected.

83. On page 6 of that Patent Office communication (copied below), the Patent Office states that Plaintiff’s 2018 patent publication includes all of the

1 elements for almost all of the claims on which Defendants are attempting to get  
2 patent protection, except for a dodecagon inner tube shape:

Application/Control Art Unit: 3677	Number: 15/932,534	Page 6
<p>3 <b>Claims 1, 4-7, 9, 12-16 and 18-19 (properly 19-20) is/are rejected under 35 U.S.C. 103 as being</b>  4 <b>unpatentable over Resh, U.S. Patent Application 2018/0009099 in view of Holden, U.S. Patent</b>  5 <b>6,805,271.</b></p>		
<p>6 Resh teaches an apparatus comprising an outer tube (2) having first and second ends, the first  7 end having a collar housing (3) and an angled detent (4), the second end of the outer tube having means  8 for attaching a tool (see Abstract, paragraph [0027]), an inner tube (5) having first and second ends and  9 including a detachable grooved grip (element 8, paragraph [0085] and received within an aperture in the  10 collar (see fig. 2a), a plurality of apertures (2a) aligned on the inner tube and the angled detent includes  11 a locking means (fig. 2c, element 6).</p>		
<p>12 Resh does not teach the inner tube being a dodecagon.</p>		
<p>13 Holden teaches a tube within a tube structure where a dodecagon is employed because it allows  14 rotation, but also permits a level of rotation resistance (Col 10, Ln 57 – Col 11, Ln 14).</p>		
<p>15 At the time of the invention it would have been obvious to one of ordinary skill in the art barring  16 any unforeseen result to provide Resh with an inner tube in the shape of Holden because the rotation  17 capabilities as taught by Holden would be beneficial for properly positioning the tool, [Claim 1].</p>		

18  
19  
20 84. Given the other facts set forth herein, this is tantamount to the Patent  
21 Office saying that Defendants copied Plaintiff’s invention, but revised the shape of  
22 the inner tube to a dodecagon. Below is a further portion of that Patent Office  
23 communication, by which the Patent Office reaches a similar conclusion about  
24 Defendants’ other claims:



Claims 2, 10 and 17 is/are rejected under 35 U.S.C. 103 as being unpatentable over Resh-

Holden as applied to claims 1, 9 and 16 above, and further in view of Spear, U.S. Patent 4,417,744.

All the aspects of the instant invention are disclosed above but for the locking means being a tapered pin.

Spear teaches a tapered pin 62 inserted into an aperture (see figs. 2-3).

At the time of the invention it would have been obvious to one of ordinary skill in the art to provide a tapered pin on the angled detent of Resh because that would permit easier entry of the pin into the aperture.

Claims 3, 8, 11 and 17 (properly 18) is/are rejected under 35 U.S.C. 103 as being unpatentable

over Resh-Holden as applied to Claims 1, 9 and 16 above, and further in view of Lacy, U.S. Patent 5,092,262

All the aspects of the instant invention are disclosed above but for the locking mechanism including a ringed pin.

Lacy teaches two nesting tubes joined by a ringed pin in apertures (see fig. 7, element 120).

At the time of the invention it would have been obvious to one of ordinary skill in the art barring any unforeseen result to provide Resh-Holden with a ringed pin as taught by Lacy instead of the mechanism of Resh because a ringed pin would more affordable and is a readily available off-the-shelf component, [3, 11, 17 (properly 18)].



85. Consistent with the Patent Office claim rejections above, the Patent Office Examiner who reviewed Defendants’ application listed Plaintiff’s 2018 patent publication as the first prior art upon which the Examiner relied for rejecting Defendants’ claims (as shown in this true and correct copy of the Examiner’s Notice of References Cited):

1  
2  
3  
4  
5  
6  
7  
8  
9  
10  
11  
12  
13  
14  
15  
16  
17  
18  
19  
20  
21  
22  
23  
24  
25  
26  
27  
28

<b>Notice of References Cited</b>		Application/Control No. 15/932,534	Applicant(s)/Patent Under Reexamination Conrad, James R.			
		Examiner MATTHEW J SULLIVAN	Art Unit 3677	Page 1 of 3		
<b>U.S. PATENT DOCUMENTS</b>						
*		Document Number Country Code-Number-Kind Code	Date MM-YYYY	Name	CPC Classification	US Classification
*	A	US-20180009099-A1	01-2018	Resh; Eric V.	B25G3/18	1/1
*	B	US-6805271-B2	10-2004	Holden; William	A47K10/38	206/409
*	C	US-5092262-A	03-1992	Lacy; Franklin R.	B63B19/02	114/343
*	D	US-4417744-A	11-1983	Spear; Kenneth J.	B62J1/08	248/411
*	E	US-20190118393-A1	04-2019	Browne; Benjamin Alan	B25B9/00	1/1
*	F	US-20180281169-A1	10-2018	Cromartie; Brad	B25G1/04	1/1
*	G	US-20180103819-A1	04-2018	Hoyle; Mark Allen	B25G1/04	1/1
*	H	US-9999970-B2	06-2018	Browning; Don Robert	B25G1/10	1/1
*	I	US-20170282348-A1	10-2017	MARK; MOSHE	A46B5/0095	1/1
*	J	US-10091948-B2	10-2018	Pringnitz; Todd	A01G3/083	1/1
*	K	US-8939051-B1	01-2015	Lofley, Sr.; Robert G.	F16B7/1418	294/210
*	L	US-9120217-B2	09-2015	Fischer, Jr.; Gary M.	B25G1/04	1/1
*	M	US-9427854-B2	08-2016	Leighton; Lisa	B25B13/06	1/1

86. For the sake of completeness, and to hopefully expedite the remainder of this lawsuit, below is a true and correct copy of the Patent Office’s Notice of Publication of Defendants’ application, indicating publication on September 12, 2019:

1  
2  
3  
4  
5  
6  
7  
8  
9  
10  
11  
12  
13  
14  
15  
16  
17  
18  
19  
20  
21  
22  
23  
24  
25  
26  
27  
28

		<b>UNITED STATES PATENT AND TRADEMARK OFFICE</b>	
		<small>UNITED STATES DEPARTMENT OF COMMERCE                  United States Patent and Trademark Office                  Address: COMMISSIONER FOR PATENTS                  P.O. Box 1450                  Alexandria, Virginia 22313-1450                  www.uspto.gov</small>	
APPLICATION NUMBER	FILING OR 371(C) DATE	FIRST NAMED APPLICANT	ATTY. DOCKET NO./TITLE
15/932,534	03/12/2018	James R. Conrad	CONRAD-IX
			<b>CONFIRMATION NO. 2743</b>
38030 JEFFREY HALL 212 CLINTON ST SANTA CRUZ, CA 95062		<b>PUBLICATION NOTICE</b>  <small>*OC000000111073250*</small>	
<b>Title:</b> Telescopic Pole For Swimming Pool Tools			
<b>Publication No.:</b> US-2019-0275659-A1 <b>Publication Date:</b> 09/12/2019			
<b>NOTICE OF PUBLICATION OF APPLICATION</b>			
The above-identified application will be electronically published as a patent application publication pursuant to 37 CFR 1.211, et seq. The patent application publication number and publication date are set forth above.			

87. Finally, below are true and correct copies of portions of Defendants’ application as published by the Patent Office, including the “Claim 1” that Defendants copied virtually verbatim from Plaintiff’s 2013 published application:

1  
2  
3  
4  
5  
6  
7  
8  
9  
10  
11  
12  
13  
14  
15  
16  
17  
18  
19  
20  
21  
22  
23  
24  
25  
26  
27  
28

(19) **United States**  
 (12) **Patent Application Publication**  
**Conrad**

(10) **Pub. No.: US 2019/0275659 A1**  
 (43) **Pub. Date: Sep. 12, 2019**

(54) **TELESCOPIC POLE FOR SWIMMING POOL TOOLS**

(52) **U.S. CL.**  
 CPC ..... *B25G 1/04* (2013.01); *F16B 7/105* (2013.01); *E04H 4/1609* (2013.01)

(71) Applicant: **James R. Conrad**, Salinas, CA (US)

(57) **ABSTRACT**

(72) Inventor: **James R. Conrad**, Salinas, CA (US)

An apparatus for cleaning swimming pools, cement finishing tools, and wire ceiling applications, having an outer tube having a collar and angled detent, and a mechanism for attaching a tool. A dodecagon shaped inner tube configured to be received within the outer tube within an aperture in the collar. The inner tube is shaped to slide within the outer tube to a selected position in relation to the outer tube, allowing for the angled detent to position and secure the inner tube within the outer tube. A plurality of apertures are aligned on the inner tube, so that the angled detent, which includes a locking mechanism, which may be a tapered or ringed pin that is operably engaged with one of the apertures, to secure the inner tube at a selected position within the outer tube.

(21) Appl. No.: 15/932,534

(22) Filed: **Mar. 12, 2018**

**Publication Classification**

(51) **Int. Cl.**  
*B25G 1/04* (2006.01)  
*E04H 4/16* (2006.01)  
*F16B 7/10* (2006.01)

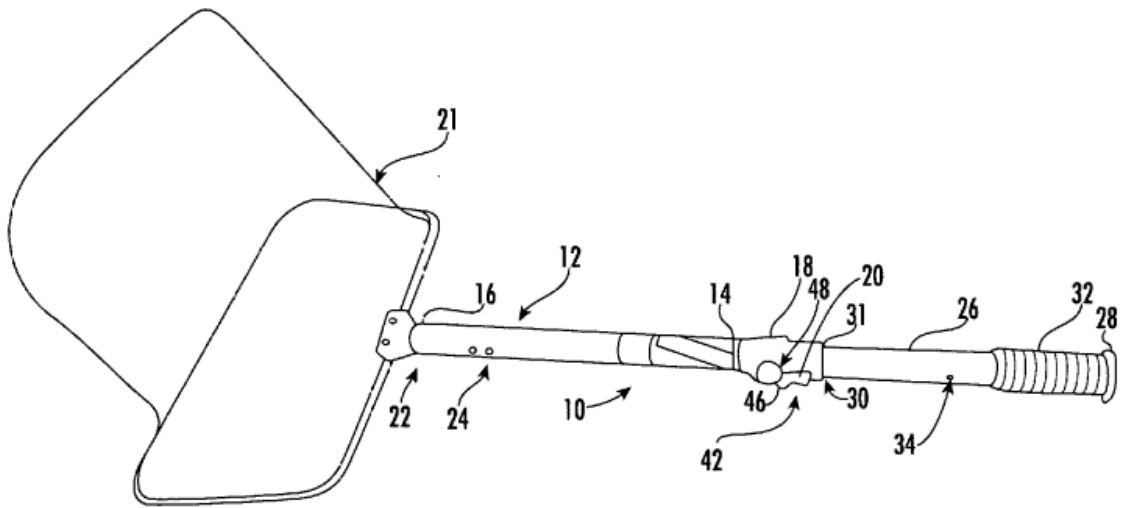

Sep. 12, 2019

4

shown and described. Accordingly, departures from such details may be made without departing from the spirit or scope of the applicant's general inventive concept.

What is claimed is:

1. An apparatus for cleaning swimming pools, cement finishing tools, ceiling wire applications, and the like, comprising:

an outer tube having a first end and a second end, said first end of the outer tube having a collar housing and angled detent, said second end of said outer tube having means for attaching a tool;

a dodecagon shaped inner tube having a first end and a second end, and includes a detachable grooved grip for grasping and positioning the apparatus; said second end of said inner tube is adapted and configured to be received within said outer tube within an aperture in said collar housing; the inner tube is shaped to slide within said outer tube to a selected position in relation to said outer tube, allowing for said angled detent to position and secure the inner tube within the outer tube; and

a plurality of apertures aligned on the inner tube, so that the angled detent, which includes a locking means, may be operably engaged with one of said apertures, to secure and position the inner tube at a selected position within said outer tube.

88. Rather than respond or contest the July 2019 Patent Office rejections, Defendants filed a "continuation-in-part" patent application,<sup>16</sup> and let their initial

<sup>16</sup> Defendants' further patent application also is based on Plaintiff's '852 Patent inventions, but Defendants amended their application and claims slightly, and they very recently obtained allowance for a different pole configuration (not any of the pole configurations discussed in this Complaint). That different configuration is one that Defendants do not even make or sell, and which at least

1 application go abandoned. Defendants’ actions are reflected in the true and correct  
 2 copies of the relevant Patent Office communications shown below:

		UNITED STATES PATENT AND TRADEMARK OFFICE		
		UNITED STATES DEPARTMENT OF COMMERCE United States Patent and Trademark Office Address: COMMISSIONER FOR PATENTS P.O. Box 1450 Alexandria, Virginia 22313-1450 www.uspto.gov		
APPLICATION NO.	FILING DATE	FIRST NAMED INVENTOR	ATTORNEY DOCKET NO.	CONFIRMATION NO.
15/932,534	03/12/2018	James R. Conrad	CONRAD-1X	2743
38030 7590 02/28/2020 JEFFREY HALL 212 CLINTON ST SANTA CRUZ, CA 95062		EXAMINER SULLIVAN, MATTHEW J		
		ART UNIT	PAPER NUMBER	
		3677		
		MAIL DATE	DELIVERY MODE	
		02/28/2020	PAPER	
<p><b>Please find below and/or attached an Office communication concerning this application or proceeding.</b></p> <p>The time period for reply, if any, is set in the attached communication.</p>				

25 arguably is not of any commercial value. It uses two “outer” tubes that telescope  
 26 onto a central “inner” tube, with the outer tubes apparently butting into each other  
 27 from collapsing the pole to a single tube length (the “collapsed” pole would still be  
 28 as long as the two outer tubes combined, because those do not collapse into each  
 other).

<b>Notice of Abandonment</b>	<b>Application No.</b> 15/932,534	<b>Applicant(s)</b> Conrad, James R.
	<b>Examiner</b> MATTHEW J SULLIVAN	<b>Art Unit</b> 3677
<i>-- The MAILING DATE of this communication appears on the cover sheet with the correspondence address--</i>		
This application is abandoned in view of:		
<p>1. <input checked="" type="checkbox"/> Applicant's failure to timely file a proper reply to the Office letter mailed on 30 July 2019.</p> <p>(a) <input type="checkbox"/> A reply was received on _____ (with a Certificate of Mailing or Transmission dated _____), which is after the expiration of the period for reply (including a total extension of time of _____ month(s)) which expired on _____.</p> <p>(b) <input type="checkbox"/> A proposed reply was received on _____, but it does not constitute a proper reply under 37 CFR 1.113 to the final rejection. (A proper reply under 37 CFR 1.113 to a final rejection consists only of: (1) a timely filed amendment which places the application in condition for allowance; (2) a timely filed Notice of Appeal (with appeal fee); or (3) if this is utility or plant application, a timely filed Request for Continued Examination (RCE) in compliance with 37 CFR 1.114. Note that RCEs are not permitted in design applications.)</p> <p>(c) <input type="checkbox"/> A reply was received on _____ but it does not constitute a proper reply, or a bona fide attempt at a proper reply, to the non-final rejection. See 37 CFR 1.85(a) and 1.111. (See explanation in box 7 below).</p> <p>(d) <input checked="" type="checkbox"/> No reply has been received.</p>		

89. In the following section, Plaintiff discusses further evidence of Defendants’ pattern of copying and infringement of Plaintiff’s ‘852 and other related patents, and how that evidence supports not just the Court finding that Plaintiff’s ‘852 Patent is valid and infringed by Defendants’ products, but also finding that Defendants are liable for pre-issuance damages and other awards to Plaintiff.

**DEFENDANTS ARE LIABLE FOR PRE-ISSUANCE DAMAGES, ENHANCED DAMAGES FOR WILLFUL INFRINGEMENT, AND REASONABLE ATTORNEY’S FEES**

90. Resh realleges and incorporates by reference the allegations set forth in paragraphs 1-81.

**The Court Should Award to Plaintiff Several Unusual Types of Relief**

91. In patent litigation, 35 U.S. Code §283 provides for injunctive relief (such as Plaintiff is seeking in the lawsuit, to force Defendants to stop infringing Plaintiff’s ‘852 Patent). Similarly, 35 U.S.C. §284 provides the main framework for compensatory damages in patent infringement actions: “Upon finding for the claimant the court shall award the claimant damages adequate to compensate for the infringement, but in no event less than a reasonable royalty for the use made of

1 the invention by the infringer, together with interest and costs as fixed by the  
2 court.” In this lawsuit, Plaintiff is requesting those types of “conventional” relief  
3 from the Court.

4 92. In certain circumstances, however, courts can make **additional awards**  
5 to patent owners, including **(a) enhanced damages, (b) reasonable attorney’s**  
6 **fees, and/or (c) “provisional damages”** (for infringement that occurs **prior** to  
7 issuance of their patent). The facts in this case establish that, in addition to  
8 conventional injunctive relief and compensatory damages, all of those other types  
9 of additional awards are appropriate here and therefore the Court should award  
10 them to Plaintiff.

11 93. The facts establishing the appropriateness of those additional awards to  
12 Plaintiff span a number of years, and at least some of those facts support more than  
13 one of those types of awards. For convenient reference, below is a summary of the  
14 general legal framework for those awards, followed by at least some of the relevant  
15 facts supporting those awards in this particular case.

16 94. Regarding an award of **enhanced damages** for patent infringement, 35  
17 U.S.C. §284 also provides that “... the court may increase the damages up to three  
18 times the amount found or assessed...” Enhanced damages serve as a punitive  
19 sanction for egregious infringement behavior. In *Read Corp. v. Portec, Inc.*, 970  
20 F.2d 816 (Fed. Cir. 1992), the Federal Circuit listed factors used to determine  
21 whether infringers’ actions warrant punishment of treble/increased/enhanced  
22 damages. The *Read* factors include the following:

- 23 (a) Whether the infringer deliberately copied the ideas or design of  
24 another;
- 25 (b) Whether the infringer, when it knew of the other’s patent  
26 protection, investigated the scope of the patent and formed a good-  
27 faith belief that it was invalid or that it was not infringed;
- 28



- 1 (c) The infringer's behavior as a party to the litigation;
- 2 (d) The infringer's size and financial condition;
- 3 (e) Closeness of the case;
- 4 (f) Duration of infringer's misconduct;
- 5 (g) Remedial action by the infringer;
- 6 (h) The infringer's motivation to harm; and
- 7 (i) Whether infringers attempted to conceal their misconduct.

8 95. In addition to enhanced damages, 35 U.S.C. 285 allows a court to award  
9 reasonable **attorney fees** to the prevailing party in exceptional cases. An  
10 exceptional case is one that stands out because of the substantive strength of a  
11 party's litigating position or the unreasonable manner in which the case was  
12 litigated. The court has considerable discretion in deciding whether to award  
13 attorney's fees. To determine whether this case is exceptional, the Court may  
14 consider factors such as:

- 15 (a) The parties' litigating positions in the case;
- 16 (b) Litigation misconduct;
- 17 (c) Litigation animus;
- 18 (d) Discovery misconduct;
- 19 (e) The jury's verdict; and
- 20 (f) Willfulness.

21 96. At this stage of this lawsuit, clearly several of those "enhanced  
22 damages" factors will depend on subsequent actions by Defendants. However, and  
23 as further alleged below, even based just on information presently available, at  
24 least factors (a) and (f) already support an award of attorney's fees. Regarding  
25 "the parties' litigating positions," Defendants have never offered even any  
26 argument that their products do not infringe, and despite having more than ten  
27 years of notice, they only recently offered any invalidity argument. They made  
28

1 their invalidity allegations **after** Plaintiff’s ‘852 Patent issued, and even then,  
 2 Defendants’ primary evidence of alleged prior art is insufficient as a matter of law.  
 3 Those and other facts summarized here (and as will be shown at trial) show that  
 4 Defendants’ infringement has been **willful** (factor (f) above supporting an award of  
 5 attorney’s fees).

6 97. Regarding “provisional” **pre-issuance damages**, in relevant part 35  
 7 U.S.C. §154(d) states:

8 (d) Provisional Rights.—

9 (1) In general.—In addition to other rights provided by this section, a  
 10 patent shall include the right to obtain a reasonable royalty from any person  
 11 who, during the period beginning on the date of publication of the  
 12 application for such patent ..., and ending on the date the patent is issued—

13 (A)

14 (i) makes, uses, offers for sale, or sells in the United States the  
 15 invention as claimed in the published patent application or imports such  
 16 an invention into the United States; or

17 (ii) if the invention as claimed in the published patent application  
 18 is a process, uses, offers for sale, or sells in the United States or imports  
 19 into the United States products made by that process as claimed in the  
 20 published patent application; and

21 (B) had actual notice of the published patent application ....

22 (2) Right based on substantially identical inventions.—

23 The right under paragraph (1) to obtain a reasonable royalty shall not  
 24 be available under this subsection unless **the invention as claimed in the**  
 25 **patent is substantially identical to the invention as claimed in the**  
 26 **published patent application.**

27 (Emphasis added).

28 98. Regarding provisional/pre-issuance damages, the facts will show that the  
 requirements above are met in this case. Among other things, (a) Defendants twice  
 had actual notice of Plaintiff’s published patent application, and (b) the invention  
 as claimed in Plaintiff’s ‘852 Patent is substantially identical to the invention as

1 claimed in the published patent application.

2 **Further Examples of Facts Supporting the Court Awarding Those**

3 **Additional Types of Relief in this Lawsuit**

4 99. Plaintiff now alleges even further of the many facts that support those  
5 additional awards to Plaintiff (beyond the facts already discussed above). Among  
6 other things, Defendants have a repeated history of (a) infringing Plaintiff's  
7 patents, and (b) as in the present dispute, baselessly alleging that Plaintiff's patents  
8 are invalid. For **all three** of Plaintiff's patents discussed below, Defendants have  
9 repeated that same pattern of behavior. Plaintiff is seeking the Court's assistance  
10 to finally put a stop to Defendants' disregard for Plaintiff's rights, and Defendants'  
11 disregard for basic principles of our patent and legal systems and our society more  
12 generally.

13 100. The Patent Office first issued to Plaintiff a related U.S. Pat. No.  
14 9,764,458 (the '458 patent), on September 19, 2017. This was the first of three  
15 patents that the Patent Office has issued for Plaintiff's swimming pool pole  
16 inventions. In that '458 patent, the claims are directed to telescoping poles having  
17 Plaintiff's inventive detent/lever lock engagement, but also having a related "water  
18 channel" feature (that helps prevent water from filling the inner tube of the pole  
19 during use). This feature keeps those poles (poles that include that feature) lighter  
20 during use and therefore easier to use (as compared to other embodiments that do  
21 not include that water channel feature).

22 101. At the time the that '458 patent issued, Plaintiff was aware of two  
23 other third-party competitors who were making poles based on Plaintiff's  
24 detent/lever lock inventions. Neither of those competitors had copied the "water  
25 channel" feature covered by Plaintiff's '458 patent.<sup>17</sup>

26 \_\_\_\_\_  
27 <sup>17</sup> These competitors were companies named Oreq and AquaEZ, two of the  
28 three mentioned above. As shown from Plaintiff's original patent application

1           102. Even though Plaintiff was not aware of Defendants’ infringement  
2 until 2018 (after the Patent Office issued Plaintiff’s ‘458 Patent), Defendants had  
3 first developed and begun showing Defendants’ infringing SnapLite poles as early  
4 as mid-2016.<sup>18</sup> However, just a few months after Plaintiff’s ‘458 patent issued,  
5 Plaintiff learned of Defendants’ copycat SnapLite poles. More specifically, in  
6 January 2018 Plaintiff was attending a trade show in Atlantic City, New Jersey,<sup>19</sup>  
7 and Defendants also were attending and showing pole products at that trade show.

8           103. At the trade show, a third party came to Plaintiff’s booth and alerted  
9 Eric Resh that Defendants were displaying in Skimlite’s booth a knock-off version  
10 of Plaintiff’s swimming pool pole. Again, prior to this, Plaintiff had not been  
11 aware that Defendants were making, using, selling, or offering to sell any  
12 telescoping pole with Plaintiff’s inventive detent/lever lock engagement (or other  
13 features). Instead, to Plaintiff’s knowledge, Defendants prior poles had all used  
14 twisting and/or clamping technology.

15           104. Mr. Resh immediately investigated by going to Skimlite’s booth. Mr.  
16 Resh saw and inspected Defendants’ knock-off poles. Mr. Resh saw that, unlike  
17 the other competitors who had copied just Plaintiff’s inventive detent/lever lock  
18 engagement, Defendants **also** had copied Plaintiff’s recently-patented “water  
19 channel” feature (covered by Plaintiff’s ‘458 patent).

20           105. At Defendants’ trade show booth, Eric Resh then immediately  
21 photographed Defendants’ knock-off pole and discussed this issue with Defendants

---

22 Claim 1 (filed in 2012 and published in 2013, and copied by Defendants in 2018),  
23 from the time of that first filing in 2012, Plaintiff has always sought patent  
24 protection for a “non-water barrier version” of Plaintiff’s pole inventions. In other  
25 words, even before and regardless of the subsequent infringements by Oreq and  
26 AquaEZ (and Defendants and others), Plaintiff has sought “non-water barrier”  
27 patent claims. Plaintiff obtained that protection in the ‘852 Patent (as well as  
28 Plaintiff’s ‘458 Patent).

<sup>18</sup> This is based on Defendants’ sworn testimony in the 2018 patent  
infringement lawsuit by Plaintiff against Defendants, discussed below.

<sup>19</sup> The show was on January 23-25, 2018.

1 James and Barrett Conrad, the two principals of Defendant Skimlite.

2 106. During that discussion, the Conrads told Mr. Resh that they had a  
3 copy of Plaintiff's '458 patent "on their desk" at their office.

4 107. During that discussion, the Conrads also said that Plaintiff's '458  
5 patent was invalid. Despite alleging that the patent was invalid, Defendants did not  
6 offer any explanation or evidence for why Plaintiff's '458 patent allegedly was  
7 invalid.

8 108. During that same discussion, the Conrads also said that Defendants'  
9 new poles did not infringe Plaintiff's '458 patent. As with Defendants' assertion  
10 of invalidity, Defendants did not offer any explanation or evidence for why  
11 Plaintiff's '458 patent allegedly was not infringed by Defendants' new poles.

12 109. During that discussion, the Conrads also said that Plaintiff would have  
13 to sue Defendants to get Defendants to stop making Defendants' new poles.

14 110. Just a few days after the trade show in Atlantic City, Defendants again  
15 showed Defendants' detent/lever poles at another trade show (the IPSSA Chapter 7  
16 San Diego Show, held on or about January 27-28, 2018, in San Diego, California).  
17 Defendants' actions made it clear that Defendants were not going to stop infringing  
18 Plaintiff's '458 patent. Accordingly, Plaintiff did file a lawsuit against Defendants  
19 in early February 2018 (Case No. CACD: 5:18-00291 JGB (KK)).

20 111. During that lawsuit, Defendants swore under penalty of perjury that  
21 the version of Defendants' poles that Plaintiff had seen at the trade show in late  
22 January 2018 was Defendants' 5th iteration of Defendants' detent/lever SnapLite  
23 poles, and that Defendants had first begun showing Defendants' SnapLite poles as  
24 early as mid-2016. As noted above, Plaintiff did not become aware of Defendants'  
25 detent/lever poles until January 2018.

26 112. That 2018 lawsuit was rather short-lived. Rather than litigate the  
27 merits of Defendants' infringement and/or validity of Plaintiff's '458 patent,  
28

1 Defendants' modified their poles to eliminate the '458 patent's water channel  
2 feature, in order to moot the lawsuit. The Court dismissed the lawsuit based on  
3 Defendants' representations that Defendants (1) had only made a few sample poles  
4 of the infringing design and (2) had changed their design to remove the infringing  
5 water channel.

6 113. Because of the other infringers (who had not included the water  
7 channel in their poles), Plaintiff already was seeking additional patent protection  
8 for Plaintiff's pole inventions (to cover embodiments of Plaintiff's inventions  
9 regardless of whether the water channel feature was included). As further  
10 discussed herein, Plaintiff's efforts eventually were successful, in part because of  
11 the copying by Defendants and third parties. Plaintiff documented and showed that  
12 copying to the Patent Office, as evidence that Plaintiff's pole inventions were  
13 patentable. Because the Patent Office Examiner did not properly consider that  
14 evidence (Defendants' copying, etc.), however, Plaintiff had to eventually file two  
15 appeals in the Patent Office. Plaintiff's appeals succeeded, and eventually (in  
16 August and October 2021), the Patent Office awarded to Plaintiff not just the '852  
17 Patent, but another related patent, U.S. Pat. No. 11,090,798 (Plaintiff's '798  
18 Patent).

19 114. Plaintiff's '798 Patent covers tubes/poles having multiple sets of  
20 attachment holes for attaching the tool to the pole. As further discussed below,  
21 while Plaintiff was pursuing that additional patent protection (and again without  
22 Plaintiff's knowledge), Defendants were busy secretly copying Plaintiff's '798  
23 inventions into virtually **all** of Defendants' poles (even Defendants' old-style  
24 twist/clamp lock poles).<sup>20</sup> Specifically, and on information and belief, Defendants  
25

---

26 <sup>20</sup> Plaintiff only became aware of Defendants' further '798 infringement upon  
27 later seeing that patented feature for sale on Defendants' commercial  
28 twisting/clamping poles. As further discussed below, Plaintiff intends to pursue  
relief for that infringement separately from this lawsuit.

1 added Plaintiff's '798 Patent "multiple sets of attachment holes" inventions into  
2 not just Defendants' lever-lock poles (that infringe Plaintiff's '852 patent).  
3 Defendants added that feature to all of Defendants' "prior art" twisting/clamping  
4 poles. Among other things, this is again evidence that Defendants believe that  
5 Plaintiff's '798 Patent "multiple sets of attachment holes" inventions are valuable  
6 and sufficiently important to add to all of Defendants' products.

7 115. Among the many other reasons for awarding additional relief to  
8 Plaintiff is Defendants' failure to comply with the Patent Office requirements, in  
9 an apparent effort to commit fraud on the Patent Office in connection with  
10 Defendants' 2018 patent application. Specifically, Defendants violated their duty  
11 to the Patent Office, by failing to bring to the Examiner's attention Plaintiff's 2013  
12 published patent application, even though (as discussed above) Defendants clearly  
13 had copied claims from that very publication!

14 116. The U.S. Patent Office rules expressly require all applicants to  
15 disclose information that is material to whether the applicant's invention may be  
16 patentable. Pertinent parts of that duty (as set forth in 37 CFR 1.56 Duty to  
17 disclose information material to patentability) are copied and highlighted below:

18  
19 **37 CFR 1.56 Duty to disclose information material to patentability.**

20 (a) A patent by its very nature is affected with a public interest. The  
21 public interest is best served, and the most effective patent examination  
22 occurs when, at the time an application is being examined, the Office is  
23 aware of and evaluates the teachings of all information material to  
24 patentability. **Each individual associated with the filing and prosecution  
25 of a patent application has a duty of candor and good faith in dealing  
26 with the Office, which includes a duty to disclose to the Office all  
27 information known to that individual to be material to patentability** as  
28 defined in this section. The duty to disclose information exists with respect  
to each pending claim until the claim is cancelled or withdrawn from  
consideration, or the application becomes abandoned. Information material  
to the patentability of a claim that is cancelled or withdrawn from

1 consideration need not be submitted if the information is not material to the  
2 patentability of any claim remaining under consideration in the application.  
3 There is no duty to submit information which is not material to the  
4 patentability of any existing claim. The duty to disclose all information  
5 known to be material to patentability is deemed to be satisfied if all  
6 information known to be material to patentability of any claim issued in a  
7 patent was cited by the Office or submitted to the Office in the manner  
8 prescribed by §§ 1.97(b)-(d) and 1.98. However, **no patent will be granted  
9 on an application in connection with which fraud on the Office was  
10 practiced or attempted or the duty of disclosure was violated through  
11 bad faith or intentional misconduct. The Office encourages applicants to  
12 carefully examine:**

9 (1) Prior art cited in search reports of a foreign patent office in a  
10 counterpart application, and

11 (2) **The closest information over which individuals  
12 associated with the filing or prosecution of a patent application  
13 believe any pending claim patentably defines, to make sure that  
14 any material information contained therein is disclosed to the  
15 Office.**

15 117. It is difficult to imagine how any information could be “closer” to  
16 Defendants’ 2018 patent application than Plaintiff’s 2013 publication from which  
17 **Defendants copied** Defendants’ Claim 1. Despite Defendants’ copying from  
18 Plaintiff’s 2013 publication, Defendants failed to file that information (Plaintiff’s  
19 2013 publication) with the Patent Office.

20 118. As mentioned above, Defendants’ copying from Plaintiff’s 2013  
21 published patent application is not just Defendants admitting infringement, but also  
22 is directly relevant to showing that Defendants are liable for pre-issuance damages.  
23 Defendants’ near verbatim copying from Plaintiff’s 2013 published patent  
24 application (discussed above) is an admission that Defendants “**had actual notice**  
25 of [Plaintiff’s 2013] published patent application” as required in order for  
26 Defendants to be liable for pre-issuance damages.

27 119. In the interest of completeness, Plaintiff discusses below further  
28



1 details regarding an obvious typographical error in Plaintiff's above Claim 1 as  
 2 published by the Patent Office in 2013.<sup>21</sup> The error could hardly be simpler – it  
 3 involved just two words. Here is a portion of a more detailed discussion below  
 4 (explaining actions Plaintiff took in the Patent Office to correct the obvious  
 5 error),<sup>22</sup> highlighting those two erroneous words:

6 File No. RESH-P3841.4

Serial No. 15/708,038

7 In the interest of making a complete and convenient record, Applicant sets  
 8 forth below a copy of the mistake in Claim 1 as it was published. Again:

9 (a) FIRST should be SECOND; and (b) INNER should be OUTER:

10  
 11 **1.** An improved telepole device, comprising:  
 12 an outer tube element having first and second ends, said  
 13 first end of the outer tube element having a collar ele-  
 14 ment associated therewith, said collar element contain-  
 15 ing a detent means;  
 16 an inner tube element having first and second ends, said  
 17 first end of the inner tube having attachment means for  
 18 removably attaching a tool;  
 19 said second end of said inner tube element being received  
 20 in the first end of the outer tube through an opening in  
 21 said collar element;  
 22 wherein said inner tube element is configured to readily  
 23 slide within said outer tube element to a selected posi-  
 24 tion along the length of the outer tube, and wherein said  
 25 detent means is configured to temporarily lock the inner  
 26 tube in that selected position within the outer tube.

27 120. As shown in the table below, Defendants' claims are so virtually

28  
 29 \_\_\_\_\_  
 30 <sup>21</sup> Plaintiff copies below substantial portions of Plaintiff's corrective filing  
 31 and explanation in the Patent Office records. Following Plaintiff's filing, the  
 32 Patent Office issued the corrected "Published Claim 1" as Claim 21 of Plaintiff's  
 33 '852 Patent.

34 <sup>22</sup> Again, this is an excerpt of Plaintiff's filing in the Patent Office, which led  
 35 the Patent Office to issue the corrected version of the claim.

1 identical (to even the uncorrected version of Plaintiff’s 2013 published claim) that  
 2 there can be no other explanation. When Defendants filed their patent application  
 3 in March 2018, Defendants had **actual notice** of Plaintiff’s patent claims that the  
 4 Patent Office had published in 2013. As shown below, in their own March 2018  
 5 application, Defendants actually copied Plaintiff’s published patent Claim 1:

<b><u>Plaintiff RESH’s Claim 1</u></b> <b><u>(PUBLISHED 2013)<sup>23</sup></u></b>	<b><u>Defendants’ Claim 1</u></b> <b><u>(Filed 2018)<sup>24</sup></u></b>
1. An improved telepole device, comprising:	1. An apparatus for cleaning swimming pools, cement finishing tools, ceiling wire applications, and the like, comprising:
an outer tube element having first and second ends, said first end of the outer tube element having a collar element associated therewith, said collar element containing a detent means; an inner tube element having first and second ends, said first end of the inner tube having attachment means for removably attaching a tool;	an outer tube having a first end and a second end, said first end of the outer tube having a collar housing and angled detent, said second end of said outer tube having means for attaching a tool;

25 \_\_\_\_\_  
 26 <sup>23</sup> U.S. Patent Office Publ. No. US2013/0326832.

27 <sup>24</sup> As shown in U.S. Patent Office PUBLICATION US20190275659A1,  
 28 published 2019-09-12. Defendants likewise similarly copied from Plaintiff’s 2013  
 publication Defendants’ two other independent claims, Claims 9 and 16.

<p><b><u>Plaintiff RESH’s Claim 1</u></b>  <b><u>(PUBLISHED 2013)<sup>23</sup></u></b></p>	<p><b><u>Defendants’ Claim 1</u></b>  <b><u>(Filed 2018)<sup>24</sup></u></b></p>
<p>said second end of said inner tube element being received in the first end of the outer tube through an opening in said collar element;</p> <p>wherein said inner tube element is configured to readily slide within said outer tube element to a selected position along the length of the outer tube, and wherein said detent means is configured to temporarily lock the inner tube in that selected position within the outer tube.</p>	<p>a dodecagon shaped inner tube having a first end and a second end, and includes a detachable grooved grip for grasping and positioning the apparatus; said second end of said inner tube is adapted and configured to be received within said outer tube within an aperture in said collar housing; the inner tube is shaped to slide within said outer tube to a selected position in relation to said outer tube, allowing for said angled detent to position and secure the inner tube within the outer tube; and</p>
	<p>a plurality of apertures aligned on the inner tube, so that the angled detent, which includes a locking means, may be operably engaged with one of said apertures, to secure and position the inner tube at a selected position within said outer tube.</p>

121. Here is a portion of materials Plaintiff filed in the Patent Office to correct that obvious error (setting forth just some of the many reasons that error was obvious):

1 Based Applicant's review of the entire publication, these two words  
2 themselves (within published Claim 1) are the only instance of this mistake – all of  
3 the many other drawings and specification references and the Abstract (such as the  
4 examples shown above) show only the correct concept – tool attachment means on  
5 the second end of the outer tube. Thus, the plain language and drawings of the

17

HTTPS://DOCXLIVE.VETTINGID/HASHED/PROCLIST/RESH/P3841.4\_L2PA\_P012\_COAT\_BHL.UPTO/COMMUNICATIONS/00000000\_DAB18-03-  
06\_SURVE\_RESPONSE/01\_01\_18\_00\_SURVE\_RESP\_2018\_04\_01\_CA\_FINAL.DOCX

11  
12 File No. RESH-P3841.4

Serial No. 15/708.038

13 published application demonstrate and make obvious the above error, especially to  
14 any persons of ordinary skill in the art.

15 Among other things, persons of ordinary skill in the art would be familiar  
16 with prior art telescoping swimming pool tools, which typically had their  
17 attachment means on the outer tube, at the "second" end. To Applicant's current  
18 knowledge, all of the prior art swimming pool poles (including those described in  
19 the various declarations and related videos and images filed in Applicant's IDS)  
20 show the attachment means on the outer tube, at the "second" end (see, for  
21 example, the Skimlite twist-lock poles discussed in Applicant's filings).

22 Especially in view of Applicant's 2013 publication in its entirety, persons of  
23 ordinary skill in the art will understand that same approach (attachment means on  
24 the outer tube, at the "second" end) was intended by Applicant in Applicant's  
25 Claim 1 as published in December 2013. Those persons of ordinary skill in the art  
26 would have understood that Applicant intended to and was pursuing patent  
27 protection for poles with attachment means on the outer tube, at the "second" end.  
28 To assert that Applicant instead was pursuing patent protection for poles with  
attachment means on the inner tube, at the "first" end, would make no sense.

In that regard, and perhaps as importantly, there does not appear to be any  
way that an apparatus could be constructed consistently with the mistaken

1 122. Plaintiff submits that, even with that obvious error, Plaintiff's issued  
 2 claim (Claim 21 in the '852 Patent) meets the requirement of being "substantially  
 3 identical" to Plaintiff's published claim (Claim 1 above). The obvious nature of  
 4 that error is just one of many additional reasons (including those discussed further  
 5 below) that the "substantially identical" requirement is met (for purposes of the  
 6 Court awarding pre-issuance damages to Plaintiff).

7 123. In fact, Defendants' copying of Plaintiff's "corrected" claim language  
 8 effectively is an even further admission by Defendants - that Defendants  
 9 understood that the published Claim 1 included an obvious error, and that the  
 10 published error was obvious to anyone reviewing the publication (such as  
 11 Defendants).

12 124. Below is a table similar to the one early in the Complaint, but  
 13 comparing the corrected Claim 1 (that issued as Claim 21) to Defendants' copied  
 14 version of that claim. Defendants' copying (of the obviously "correct" claim)  
 15 results in the Defendants' additional identical language highlighted in gray, in the  
 16 second row of the table below:

<u>Plaintiff RESH's Claim 1 (With Obvious Two Word Error CORRECTED)</u>	<u>Defendants' Claim 1 (Filed 2018)</u>
1. An improved telepole device, comprising:	1. An apparatus for cleaning swimming pools, cement finishing tools, ceiling wire applications, and the like, comprising:

<p><b><u>Plaintiff RESH’s Claim 1 (With Obvious Two Word Error CORRECTED)</u></b></p>	<p><b><u>Defendants’ Claim 1 (Filed 2018)</u></b></p>
<p>an outer tube element having first and second ends, said first end of the outer tube element having a collar element associated therewith, said collar element containing a detent means; an inner tube element having first and second ends, <del>said first second end of the inner</del> outer tube having attachment means for removably attaching a tool;</p>	<p>an outer tube having a first end and a second end, said first end of the outer tube having a collar housing and angled detent, <del>said second end of said outer tube having means for attaching a tool;</del></p>
<p>said second end of said inner tube element being received in the first end of the outer tube through an opening in said collar element;</p> <p>wherein said inner tube element is configured to readily slide within said outer tube element to a selected position along the length of the outer tube, and wherein said detent means is configured to temporarily lock the inner tube in that selected position within the outer tube.</p>	<p>a dodecagon shaped inner tube having a first end and a second end, and includes a detachable grooved grip for grasping and positioning the apparatus; said second end of said inner tube is adapted and configured to be received within said outer tube within an aperture in said collar housing; the inner tube is shaped to slide within said outer tube to a selected position in relation to said outer tube, allowing for said angled detent to position and secure the inner tube within the outer tube; and</p>
	<p>a plurality of apertures aligned on the inner tube, so that the angled detent, which includes a locking means, may be operably engaged with one of said apertures, to secure and position the inner tube at a selected position within said outer tube.</p>

125. In other words, the “corrected” language of the claim is **exactly** what Defendants used in their own patent application. It was obvious to Defendants that Plaintiff’s published Claim 1 (above) had two words inadvertently in error, so Defendants “copied” the corrected version of that claim into Defendants’ 2018

1 patent application. Here again is that evidence, showing (a) not only that  
 2 Defendants had the required “actual notice” of Plaintiff’s published claim, but (b)  
 3 also that Defendants understood that Plaintiff’s published claim had an obvious  
 4 error in it – Defendants **corrected** that error in Defendants’ own filing!

<b><u>Plaintiff RESH’s Claim 1 (With Obvious Two-Word Error CORRECTED)</u></b>	<b><u>Defendants’ Claim 1 (Filed 2018)</u></b>
an outer tube element having first and second ends, said first end of the outer tube element having a collar element associated therewith, said collar element containing a detent means; an inner tube element having first and second ends, said first second end of the inner outer tube having attachment means for removably attaching a tool;	an outer tube having a first end and a second end, said first end of the outer tube having a collar housing and angled detent, said second end of said outer tube having means for attaching a tool;

15 126. In addition to having **actual notice** of the Patent Office’s foregoing  
 16 2013 publication of Plaintiff’s application, Defendants likewise had **actual notice**  
 17 of a second Patent Office publication related to Plaintiff’s ‘852 Patent claims.  
 18 Defendants’ actual notice of this second Patent Office publication is indisputable  
 19 based on Patent Office records from Defendants’ own above-mentioned patent  
 20 application. As set forth above (and as excerpted below), in a February 2020  
 21 communication, the Patent Office sent to Defendants a copy of Plaintiff’s  
 22 published U.S. Patent Publication No. 2018/0009099:25

25 \_\_\_\_\_  
 26 <sup>25</sup> Plaintiff notes that Defendants may have received “actual notice” of  
 27 Plaintiff’s claims in this second publication earlier and/or through other means  
 28 (besides the indisputable communication of same from the Patent Office to Defendants).

Application/Control Number: 15/932,534  
 Art Unit: 3677

Page 6

Claims 1, 4-7, 9, 12-16 and 18-19 (properly 19-20) is/are rejected under 35 U.S.C. 103 as being unpatentable over Resh, U.S. Patent Application 2018/0009099 in view of Holden, U.S. Patent 6,805,271.

127. As mentioned above, in that same Patent Office communication, the Patent Office Examiner sent the following list of references that the Examiner had located, and included the foregoing Plaintiff’s patent publication at the very top of the list (the following is a true and correct copy of a portion of that Patent Office record):

<i>Notice of References Cited</i>		Application/Control No. 15/932,534	Applicant(s)/Patent Under Reexamination Conrad, James R.			
		Examiner MATTHEW J SULLIVAN	Art Unit 3677	Page 1 of 3		
U.S. PATENT DOCUMENTS						
*		Document Number Country Code-Number-Kind Code	Date MM-YYYY	Name	CPC Classification	US Classification
*	A	US-20180009099-A1	01-2018	Resh; Eric V.	B25G3/18	1/1
*	B	US-6805271-B2	10-2004	Holden; William	A47K10/38	206/409
*	C	US-5092262-A	03-1992	Lacy; Franklin R.	B63B19/02	114/343
*	D	US-4417744-A	11-1983	Spear; Kenneth J.	B62J1/08	248/411
*	E	US-20190118393-A1	04-2019	Browne; Benjamin Alan	B25B9/00	1/1
*	F	US-20180281169-A1	10-2018	Cromartie; Brad	B25G1/04	1/1
*	G	US-20180103819-A1	04-2018	Hoyle; Mark Allen	B25G1/04	1/1
*	H	US-9999970-B2	06-2018	Browning; Don Robert	B25G1/10	1/1
*	I	US-20170282348-A1	10-2017	MARK; MOSHE	A46B5/0095	1/1
*	J	US-10091948-B2	10-2018	Pringnitz; Todd	A01G3/083	1/1
*	K	US-8939051-B1	01-2015	Lofley, Sr.; Robert G.	F16B7/1418	294/210
*	L	US-9120217-B2	09-2015	Fischer, Jr.; Gary M.	B25G1/04	1/1
*	M	US-9427854-B2	08-2016	Leighton; Lisa	B25B13/06	1/1

128. Below is a true and correct copy of a portion of that Patent Office record (the first page of that Patent Office second publication related to Plaintiff’s ‘852 Patent application). Among other things, the publication date is January 11, 2018, just prior to the 2018 lawsuit by Plaintiff against Defendants discussed herein. Upon information and belief, Plaintiff alleges that Defendants had **actual**



**notice** of this publication much earlier than the February 2020 Patent Office communication. More specifically, and again upon information and belief, Plaintiff alleges that Defendants had **actual notice** of this publication at least as early as on or around the time of the aforementioned 2018 lawsuit, in connection with (a) being found out and then sued by Plaintiff in early 2018 and (b) Defendants’ related efforts to defend against that lawsuit or otherwise:



US 20180009099A1

(19) **United States**  
 (12) **Patent Application Publication** (10) **Pub. No.: US 2018/0009099 A1**  
**Resh** (43) **Pub. Date: Jan. 11, 2018**

---

(54) <b>TELEPOLE APPARATUS AND RELATED METHODS</b> (71) Applicant: <b>Eric V. Resh</b> , Temecula, CA (US) (72) Inventor: <b>Eric V. Resh</b> , Temecula, CA (US) (21) Appl. No.: <b>15/708,038</b> (22) Filed: <b>Sep. 18, 2017</b> <p style="text-align: center;"><b>Related U.S. Application Data</b></p> (63) Continuation of application No. 13/624,702, filed on Sep. 21, 2012, now Pat. No. 9,764,458, Continuation-in-part of application No. 13/844,561, filed on Mar. 15, 2013. (60) Provisional application No. 61/538,074, filed on Sep. 22, 2011, provisional application No. 61/538,074, filed on Sep. 22, 2011. <p style="text-align: center;"><b>Publication Classification</b></p> (51) <b>Int. Cl.</b> <i>B25G 1/04</i> (2006.01) <i>B25G 3/18</i> (2006.01)	(52) <b>U.S. Cl.</b> CPC <i>B25G 1/04</i> (2013.01); <i>B25G 3/18</i> (2013.01) (57) <b>ABSTRACT</b> An improved telepole device having attachment means for attaching swimming pool cleaning, and other tools. The improved telepole device preferably includes an inner tube which freely slides within an outer tube, and a locking device to temporarily secure the inner tube in a desired position within the outer tube. A preferred lightweight design may be at least partially hollow along the length of the tube(s), and durability may be provided by inner/reinforcement wall(s) that extend across the hollow portion(s) of one or both of the tubes. On the end of the outer tube through which the inner tube slides/extends is a collar element attached thereto and comprised of a locking device having a detent mechanism for “locking” the inner tube in place within the outer tube. Preferably, the collar’s opening and the profile of the inner tube have one or more sides that, due to their relative position with respect to each other, can prevent the inner tube from rotating within the collar. Further, the inner tube preferably has a series of holes along its length which are positioned to receive a pin element of the detent mechanism. Further, the end of the outer tube opposite the collar preferably has attachment holes configured to receive attachable and detachable swimming pool cleaning tools, and an additional set of holes that allow water to drain from the outer tube while a tool is attached.
---	--



129. Regarding the second main requirement above for an award of “provisional/pre-issuance” damages, Plaintiff’s issued ‘852 Patent claims include

1 ones that are “substantially identical” to ones that were published, and that cover  
 2 Defendants’ pole products. Regarding the Patent Office’s publication of Plaintiff’s  
 3 application in December 2013, and as briefly mentioned above, Plaintiff discussed  
 4 this “substantially identical” in a filing with the Patent Office (filed on October 18,  
 5 2019). True and correct copies of relevant portions of that filing are set forth  
 6 below. Upon information and belief, the statements set forth below (from that  
 7 October 18, 2019 filing) themselves are true and correct:

8  
 9 In addition, in the present amendment Applicant has added “new” Claims

10 53-55. As explained below, these are the same Claims as original Claims 1-3 that  
 11 were published on Dec. 12, 2013 (in the parent application (Ser. No. 13/844,561)  
 12 as Publ. No. US2013/0326832), with the exception of correcting a typographical  
 13 error in Claim 1/53. During earlier prosecution of Applicant’s relevant  
 14 applications, Applicant had canceled those claims. Applicant now seeks allowance  
 15 of same as discussed below.  
 16  
 17

18 More specifically, in the October 16, 2019 IDS materials (including the  
 19 several declarations filed therewith) and in the remarks below, Applicant seeks to:

- 20 1. Further confirm and authenticate certain portions of the materials and  
 21 information filed October 1, 2019 (in case that is helpful or necessary),  
 22 via portions of the Declaration of Eric Resh.  
 23  
 24  
 25

1  
2  
3  
4  
5  
6  
7  
8  
9  
10  
11  
12  
13  
14  
15  
16  
17  
18  
19  
20  
21  
22  
23  
24  
25  
26  
27  
28

**2. Claims 1-3 (New Claims 53-55) Were Published With a Typo that was Apparent to Persons of Ordinary Skill in the Art**

As noted above, Applicant is adding “new” Claims 53-55 to this application via this Second Supplemental Amendment, and those are copies (with one corrected typo) of previously published Claims 1-3. Apparently, there is no requirement for Applicant to provide the following explanation regarding that typographical error, and the Examiner may have no authority or responsibility to review and consider same. Thus, rather than include this section of remarks in this filing, Applicant apparently could simply (a) add these claims as new Claims 53-55

1 File No. RESH-P3841.4

Serial No. 15/708,038

2 as set forth below and (b) request that those claims be allowed along with the other  
3 claims pending herein.

4  
5 Instead, however, in an excess of caution and in an effort at transparency,  
6 Applicant takes this opportunity to respectfully try to provide a clear prosecution  
7 record regarding adding back those Claims 53-55 below (previously published as  
8 Claims 1-3). Applicant's efforts in that regard include this section (explaining a  
9 typographical error in Claim 1 as it was published) and section 3 below (discussing  
10 the prosecution history of that Claim 1).

11  
12 Applicant also notes that Claims 2 and 3 also were published and depended  
13 from Claim 1, and Applicant has repeated that dependency in Claims 54 and 55  
14 added as new claims below. As set forth in section 4 below, especially that Claim  
15 2/54 should be allowed as being very similar to other claims that were already  
16 pending herein.

17  
18  
19 Claim 1 as published is at least similar in scope to claims pending in the  
20 current application. For convenience and by way of example, Applicant has  
21 prepared the table below comparing Claim 1 (as originally published in December  
22 2013) with currently pending Claim 34. As shown below, those claims have  
23 substantial portions that are nearly identical: (a) exact/matching language is  
24

File No. RESH-P3841.4

Serial No. 15/708,038

highlighted in yellow, (b) other language is not highlighted, and (c) the  
aforementioned typographical mistake is highlighted in purple:

<i>Independent Claim 1 as PUBLISHED on Dec. 12, 2013 (US2013/0326832)</i>	<i>Independent Claim 34 as currently PENDING (filed on Oct 1, 2019)</i>
An improved telepole device, comprising: an outer tube element having first and second ends, said first end of the outer tube element having a collar element associated therewith, said collar element containing a detent means;  an inner tube element having first and second ends, said first end of the inner tube having attachment means for removably attaching a tool;  said second end of said inner tube element being received in the first end of the outer tube through an opening in said collar element;  wherein said inner tube element is configured to readily slide within said outer tube element to a selected position along the length of the outer tube, and wherein said detent means is	A telescoping pole apparatus, including: an outer tube having first and second ends, said first end of the outer tube having a collar associated therewith, said collar containing a selectively actuatable detent, said second end of said outer tube having structure for removably attaching a tool; an inner tube having first and second ends, said first end of said inner tube including a grip attached to the inner tube for a user to grasp and manipulate the apparatus. said second end of said inner tube being slidably received in the first end of the outer tube through an opening in said collar, said inner tube having a plurality of detent holes positioned to be engaged with said actuatable detent, said inner tube being a single wall tube that is hollow along at least substantially its length between said first and second ends of said inner tube; and said inner tube configured to slide within said outer tube to a selectable position relative to the outer tube, at which position said detent is configured to temporarily engage and

8

HTTP://DUCS.LIVE.AET/MSD/DA/SHR/POC/LET/RESH/P3841.4\_USPA\_POLE\_CONF\_BRI\_1/FTO/COMMUNICATIONS/2019/04/01\_15/2019-01-06\_01/019\_888P/04/01\_15\_20\_01/019\_888P\_2019\_04\_01\_CA\_FINAL.DOCX

File No. RESH-P3841.4

Serial No. 15/708,038

<i>Independent Claim 1 as PUBLISHED on Dec. 12, 2013 (US2013/0326832)</i>	<i>Independent Claim 34 as currently PENDING (filed on Oct 1, 2019)</i>
configured to temporarily lock the inner tube in that selected position within the outer tube.	hold said inner tube.

1 As mentioned above, Applicant has corrected the above typographical error  
2 in filing the corresponding “new” Claim 53 below. Specifically, the language in  
3 the left column above is copied into Claim 53 with the exception of correcting the  
4 two purple words (“first” corrected to “second,” and “inner” corrected to “outer”).  
5

6 As further explained below, Applicant respectfully submits that the above  
7 error in published Claim 1 would have been obvious to a person of ordinary skill in  
8 the art when reviewing Applicant’s 2013 published application. Such persons of  
9 ordinary skill in the art would have understood that, instead of the two purple  
10 words above, that part of Claim 1 was intended to address and define the second  
11 end of the outer tube.  
12

13 Those persons of ordinary skill in the art would have included Applicant’s  
14 competitors and other third parties. In addition to the plain intent and meaning of  
15 the publication as a whole (discussed below), those competitors and other third  
16 parties also would have likely seen Applicant’s commercial products (which  
17 embody the correct construction of the second end of the outer tube), and/or have  
18  
19

1 File No. RESH-P3841.4

Serial No. 15/708,038

2 received other actual notice of the correct “claim” focus of that Claim 1, prior to  
3 the copying of Applicant’s invention that is discussed in Applicant’s  
4 aforementioned October 1, 2019 filing.  
5

6 Examples of Applicant introducing and promoting Applicant’s pole  
7 inventions at trade shows and in other publications, and the industry’s reception  
8 and reactions to those promotions, are discussed in the various declarations filed in  
9 Applicant’s recent IDS. The declarations and other materials also show the  
10 reactions of multiple competitors who saw Applicant’s pole inventions –  
11 **competitors quickly began copying Applicant’s inventions**. Clearly, those  
12 competitors understood the thrust of Applicant’s patent efforts, because they  
13 copied them.  
14  
15

16 Applicant’s mistake/error in the language of Claim 1 is plainly evident in the  
17 December 2013 publication as a whole. Although the mistake would have been  
18 obvious to anyone reading the publication, it would have been especially obvious  
19 to persons of ordinary skill in the art. As explained below, throughout the  
20 publication (including repeatedly on the first page of the publication), Applicant  
21 discloses and explains that the tool attachment means is on second end of the outer  
22 tube. In that regard, below are some highlighted excerpts from the application as  
23 published in December 2013. These demonstrate that the Claim 1 error  
24  
25  
26

1  
2  
3  
4  
5  
6  
7  
8  
9  
10  
11  
12  
13  
14  
15  
16  
17  
18  
19  
20  
21  
22  
23  
24  
25  
26  
27  
28

File No. RESH-P3841.4

Serial No. 15/708,038

(highlighted in purple above) was a mistake that would have been evident to any persons of ordinary skill in the art reviewing that publication, and that the correct/actual claim protection being sought by Applicant was for attachment means on the second end of the outer tube.

In fact, except for the single typographical error in Claim 1 itself, the entire publication, including the Abstract and specification and drawings, shows that the relevant tool attachment means is on the second end of the outer tube. Below are examples from the publication itself (with highlighting):



File No. RESH-P3841.4

Serial No. 15/708,038

**FRONT PAGE (the lower half of the page is a copy of Fig. 26):**



(19) **United States**

(12) **Patent Application Publication**  
RESH

(10) **Pub. No.: US 2013/0326832 A1**  
(43) **Pub. Date: Dec. 12, 2013**

(54) **TELEPOLE APPARATUS AND RELATED METHODS**

(52) **U.S. Cl.**  
CPC ..... *B25G 1/04* (2013.01)  
USPC ..... 15/144.4; 81/489

(71) Applicant: ERIC V. RESH, Temecula, CA (US)

(72) Inventor: ERIC V. RESH, Temecula, CA (US)

(57) **ABSTRACT**

An improved telepole device having attachment means for attaching swimming pool cleaning, and other tools. The improved telepole device preferably includes an inner tube which freely slides within an outer tube, and a locking device to temporarily secure the inner tube in a desired position within the outer tube. A preferred lightweight design may be at least partially hollow along the length of the tube(s), and durability may be provided by inner/reinforcement wall(s) that extend across the hollow portion(s) of one or both of the tubes. On the end of the outer tube through which the inner tube slides/extends is a collar element attached thereto and comprised of a locking device having a detent mechanism for "locking" the inner tube in place within the outer tube. Preferably, the collar's opening and the profile of the inner tube have one or more sides that, due to their relative position with respect to each other, can prevent the inner tube from rotating within the collar. Further, the inner tube preferably has a series of holes along its length which are positioned to receive a pin element of the detent mechanism. Further, the end of the outer tube opposite the collar preferably has attachment holes configured to receive attachable and detachable swimming pool cleaning tools, and an additional set of holes that allow water to drain from the outer tube while a tool is attached.

(21) Appl. No.: 13/844,561

(22) Filed: Mar. 15, 2013

**Related U.S. Application Data**

(63) Continuation-in-part of application No. 13/624,702, filed on Sep. 21, 2012.

(60) Provisional application No. 61/538,074, filed on Sep. 22, 2011.

**Publication Classification**

(51) **Int. Cl.**  
*B25G 1/04* (2006.01)

**IMPROVED TELESCOPIC POLE-PREFERRED EMBODIMENT**

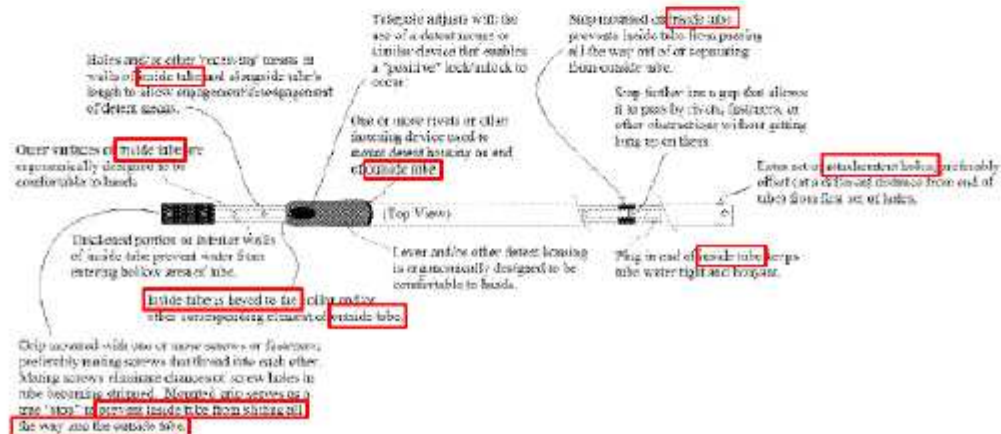

File No. RESH-P3841.4

Serial No. 15/708,038

**Page TWO, Figure 1:**

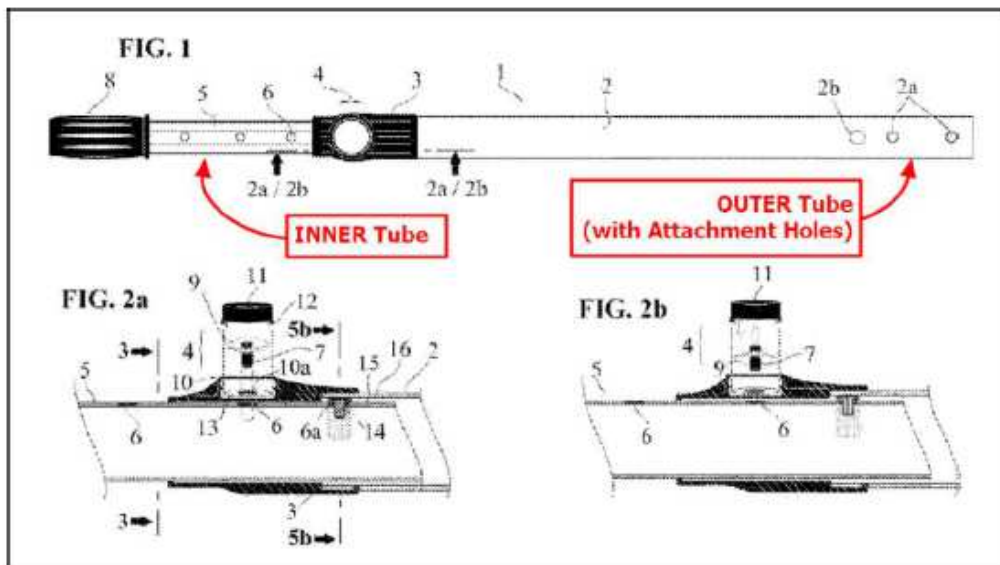

**FIG. 34:**

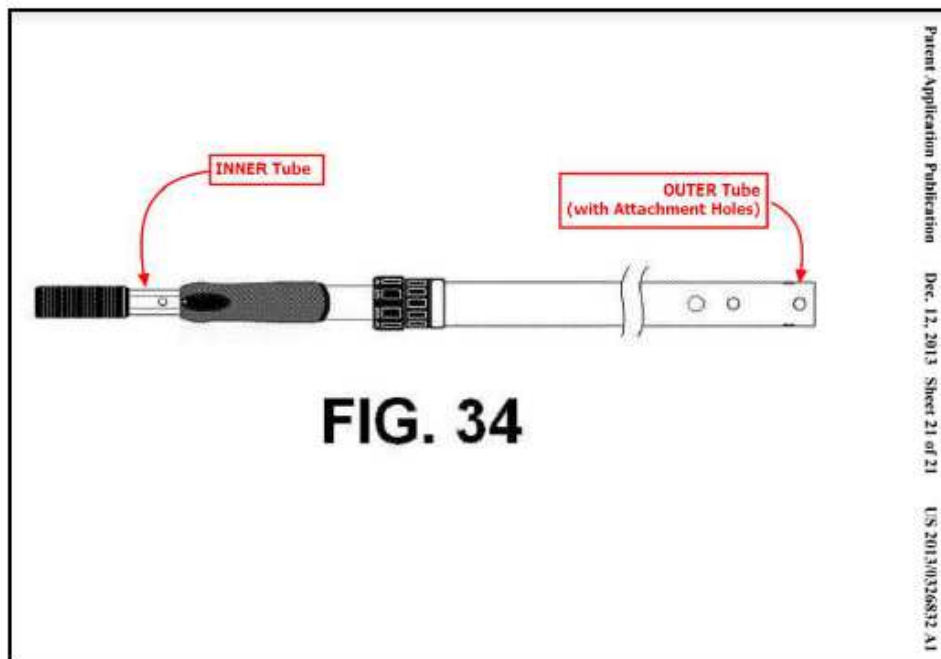

File No. RESH-P3841.4

Serial No. 15/708,038

**Pars. 26 and 27 of the specification:**

US 2013/0326832 A1

4

position with respect to each other, can prevent the inner tube from rotating within the collar. Further, the inner tube preferably has a series of holes along its length which are positioned to receive a pin element of the detent mechanism. The pin element is preferably attached to a spring element and held in place by a housing which is formed into the collar. In its normal "resting" position, the spring pushes the pin towards the inner tube such that, when the pin is aligned with one of the holes in the inner tube, the pin sits in the hole and "locks" the inner tube in position so that it cannot slide/rotate within the outer tube or collar. Also preferably, within an upper portion of the housing above the pin is a button that, when depressed, forces the spring to reverse itself from its normal "resting" position and consequently lifts/releases the pin from its normal position in the housing so that the inner tube may be moved to a new position. Further, **the end of the outer tube opposite the collar preferably has attachment holes configured to receive attachable and detachable swimming pool cleaning tools,** and an additional set of holes that allow water to drain from the outer tube while a tool is attached.

[0027] A further object of my invention is to provide a telepole for cleaning swimming pools, with a detent mechanism as described above, and characteristics that prevent water from entering the inner tube during use so as to preserve the inner tube's buoyancy. In a preferred embodiment, a barrier is formed or otherwise provided inside the inner tube along its length and adjacent to the length-selection holes, to prevent water that may flow through those holes from entering the bulk of the inside portion of the inner tube. In addition, the telepole's buoyancy preferably is further maintained by a plug which is preferably mounted into or otherwise on the end of the inner tube that is opposite the gripping portion. The plug prevents water from entering the inner tube through its end. **The end of the outer tube opposite the collar preferably has holes configured to receive attachable and detachable swimming pool cleaning tools.**

[0028] Another object of my invention is to provide a telepole for cleaning swimming pools, with a compression device

File No. RESH-P3841.4

Serial No. 15/708,038

**Par. 95:**

Dec. 12, 2013

6

out a detent locking device 4 mounted thereon, and an inner/ upper tube 5 that slides through an opening in the collar element and within the outer tube. Preferably, the inner/upper tube has a profile with a smaller circumference than that of the opening of the collar element and the outer/lower tube so that it may readily slide within/through those elements in order to provide a telepole device having an adjustable length. Further, the inner/upper tube has a gripping portion 8 that may be attached with rivets, screws or other temporary or (semi-) permanent attachment devices. The gripping portion provides an area for a user to grip/grasp the telepole device and also prevents the inner tube from sliding entirely within the outer tube as the circumference of the gripping portion is larger than that of the collar element and/or outer/lower tube. Further, attachment devices (rivets, screws, or the like) can prevent the gripping portion from being "bumped" off the end of the tube when the inner tube slides into the outer tube, and they also make removing and/or replacing a worn handle possible.

[0095] Preferably, the outer/lower tube has a series of openings/holes 2a for receiving attachment means of cleaning tools, and has at least one drain hole 2b for allowing water trapped in the outer/lower tube to drain out. As will be further described herein, some of the many alternative embodiments of the invention can be practiced without all of these elements. Moreover, persons of ordinary skill in the art will understand that the elements described herein may even be provided in other embodiments in a wide variety of other forms depending on the desired use/application of the device.

File No. RESH-P3841.4

Serial No. 15/708,038

**Pars. 167 and 168:**

[0166] Housing is mounted to outside tube in a manner that makes the housing removable/replaceable.

[0167] End of outer tube has additional set of holes about its diameter to receive attachable/detachable tools

[0168] Additional set of tool attachment holes is placed at a different distance from tube's end than first set of tool attachment holes.

[0169] Telepole with compression locking device, said compression device (as in FIGS. 10, 11, 12a-d) having the ability to 'mate' with ribs, ridges, etc. formed on inside tube.

Dec. 12, 2013

11

File No. RESH-P3841.4

Serial No. 15/708,038

In the interest of making a complete and convenient record, Applicant sets forth below a copy of the mistake in Claim 1 as it was published. Again:

(a) FIRST should be SECOND; and (b) INNER should be OUTER:

1. An improved telepole device, comprising:  
 an outer tube element having first and second ends, said first end of the outer tube element having a collar element associated therewith, said collar element containing a detent means;  
 an inner tube element having first and second ends, said first end of the inner tube having attachment means for removably attaching a tool;  
 said second end of said inner tube element being received in the first end of the outer tube through an opening in said collar element;  
 wherein said inner tube element is configured to readily slide within said outer tube element to a selected position along the length of the outer tube, and wherein said detent means is configured to temporarily lock the inner tube in that selected position within the outer tube.

Based Applicant's review of the entire publication, these two words themselves (within published Claim 1) are the only instance of this mistake – all of the many other drawings and specification references and the Abstract (such as the examples shown above) show only the correct concept – tool attachment means on the second end of the outer tube. Thus, the plain language and drawings of the

1 File No. RESH-P3841.4

Serial No. 15/708,038

2 published application demonstrate and make obvious the above error, especially to  
3 any persons of ordinary skill in the art.  
4

5 Among other things, persons of ordinary skill in the art would be familiar  
6 with prior art telescoping swimming pool tools, which typically had their  
7 attachment means on the outer tube, at the “second” end. To Applicant’s current  
8 knowledge, all of the prior art swimming pool poles (including those described in  
9 the various declarations and related videos and images filed in Applicant’s IDS)  
10 show the attachment means on the outer tube, at the “second” end (see, for  
11 example, the Skimlite twist-lock poles discussed in Applicant’s filings).  
12 Especially in view of Applicant’s 2013 publication in its entirety, persons of  
13 ordinary skill in the art will understand that same approach (attachment means on  
14 the outer tube, at the “second” end) was intended by Applicant in Applicant’s  
15 Claim 1 as published in December 2013. Those persons of ordinary skill in the art  
16 would have understood that Applicant intended to and was pursuing patent  
17 protection for poles with attachment means on the outer tube, at the “second” end.  
18 To assert that Applicant instead was pursuing patent protection for poles with  
19 attachment means on the inner tube, at the “first” end, would make no sense.  
20  
21  
22  
23

24 In that regard, and perhaps as importantly, there does not appear to be any  
25 way that an apparatus could be constructed consistently with the mistaken  
26

File No. RESH-P3841.4

Serial No. 15/708,038

language. In other words, if the INNER tube had the attachment means at its second end, the inner tube could not be telescoped out of or extended from the outer tube. Instead, the inner tube would be “locked” from telescoping out of the outer tube, by the grip at a first end and the attached tool at its second end. Extending or retracting that inner tube would be impossible – the outer tube would at most be slidable along the length of the inner tube (like a roll of paper towels moving slightly to the left or right around the fixed length of a center rod). The overall length of the “center/inside” pole/rod would not be adjustable – it would be fixed to the exact length of that “locked inside” inner tube.

**3. Original Claim 1 (New Claim 53) Should be Allowed as Corrected**

Below is a summary of the prosecution history of Claim 1 (“new” Claim 53 below), beginning from the original parent application.

<i>Date</i>	<i>Patent Office Action Description</i>	<i>Applicant Action re Claim 1</i>
<b>December 12, 2013</b>	Published as US2013/0326832	
<b>Feb 26, 2015 Office Action</b>	Rejected under 102(b) over Lofley publication ‘357, and by Fenstemaker publication ‘738.	Applicant amended Claim 1
<b>Nov 18, 2015 Final Office Action</b>	Rejected under 103(a) over Lanzarone in view of Canale or Goulet	Applicant amended Claim 1
<b>May 2, 2016 Election Requirement</b>		Applicant elected Claims 1-7, 9-14, and 18-23
<b>Sept 6, 2016</b>	Rejected under 103(a) over	Applicant



In passing, Applicant notes that, in Applicant's August 26, 2015 response to the first Office Action, Applicant corrected the typographical error in Claim 1 that

20

HTTPS://ID.DOCS.LIVE.NET/36SDSD1A52BD96FC/CLIENTS/RESH/P3841.4\_USPA\_POLE\_CONF\_3841.1/PTO COMMUNICATIONS/2019-04-01\_OA/2019-10-06\_SUPPL\_RESPONSE/2019\_10\_18\_ID\_SUPPL\_RESP\_2019\_04\_01\_OA\_FINAL.DOCX

File No. RESH-P3841.4

Serial No. 15/708,038

is discussed herein. As a result, any third party reviewing Applicant's application file history after that August 26, 2015 amendment would confirm their existing understanding about that typographical mistake. In that regard, below is Applicant's amendment of Claim 1 filed on August 26, 2015, including the correction as highlighted:

Please amend the claims as follows:

1. (Currently Amended) An improved telepole device Apparatus for cleaning swimming pools and similar bodies of water, comprising including:

an outer tube element having first and second ends, said first end of the outer tube element having a collar element associated therewith, said collar element containing a selectively actuable detent means, said second end of said outer tube having structure for removably attaching a tool;

an inner tube element having first and second ends, said first end of the inner tube having attachment means a grip for a user to grasp and manipulate the apparatus removably attaching a tool;

said second end of said inner tube element being received in the first end of the outer tube through an opening in said collar element;

wherein said inner tube element is configured to readily slide within said outer tube element to a selected position along the length of relative to the outer tube, and wherein said detent means is configured to temporarily lock the said inner tube in that selected position within the said outer tube.

1 130. Plaintiff's "corrected" Claim 1 (as discussed above and as filed as  
 2 Claim 53 in Plaintiff's foregoing October 9, 2019 Patent Office filing) is shown  
 3 below as a true and correct copy of how Plaintiff filed that claim in that October 9,  
 4 2019 Patent Office filing:

5 53. (New) An improved telepole device, comprising:  
 6 an outer tube element having first and second ends, said first end of the outer  
 7 tube element having a collar element associated therewith, said collar element  
 8 containing a detent means, said second end of the outer tube having attachment  
 9 means for removably attaching a tool;  
 10 an inner tube element having first and second ends;  
 11 said second end of said inner tube element being received in the first end of  
 12 the outer tube through an opening in said collar element;  
 13 wherein said inner tube element is configured to readily slide within said outer tube  
 14 element to a selected position along the length of the outer tube, and wherein said  
 15 detent means is configured to temporarily lock the inner tube in that selected  
 16 position within the outer tube.  
 17  
 18

19 90

20 HTTPS://D.DOCX.LIVE.NET/36SD5D3A52BD96FCCLIDENTS/RESHP/3841.4\_USPA\_POLE\_CONT\_3841.1/PTO COMMUNICATIONS/2019-04-01\_OA/2019-10-06\_SUPPL\_RESPONSE/2019\_10\_18\_2D\_SUPPL\_RESP\_2019\_04\_01\_OA\_FINAL.DOCX

21 131. That "corrected" Claim 1 (as published; corrected as Claim 53 in  
 22 Plaintiff's foregoing October 9, 2019 Patent Office filing) was issued in Plaintiff's  
 23 '852 Patent as Claim 21. A true and correct copy of that issued Claim 21 is set  
 24 forth here:  
 25  
 26  
 27  
 28

**US 11,141,852 B2**

**20**

1 which the  
2 90 degrees  
3 around a

4  
5 letent holes 5  
6 ons for said

7 ve having a  
8 of said inner  
9 ie length of 10  
partially in

10 including a

11 outer tubes 15  
12 uch as alu-

13 id first end 20  
14 l therewith,  
15 able detent,  
structure for

16 id first end 25  
17 to the inner  
18 apparatus;  
19 between said  
tube having  
intermediate 30

tube having a plurality of detent holes positioned to be engaged with said actuatable detent of said intermediate tube's collar;

said intermediate tube configured to slide within said outer tube to a selectable position relative to said outer tube, at which position said detent of said outer tube is configured to temporarily engage and hold said intermediate tube; and

said inner tube configured to slide within said intermediate tube to a selectable position relative to said intermediate tube, at which position said detent of said intermediate tube is configured to temporarily engage and hold said inner tube.

**21. An improved telepole device, comprising:**  
an outer tube element having first and second ends, said first end of the outer tube element having a collar element associated therewith, said collar element containing a detent means, said second end of the outer tube having attachment means for removably attaching a tool;  
an inner tube element having first and second ends; said second end of said inner tube element being received in the first end of the outer tube through an opening in said collar element;  
wherein said inner tube element is configured to readily slide within said outer tube element to a selected position along the length of the outer tube, and wherein said detent means is configured to temporarily lock the inner tube in that selected position within the outer tube.

20 132. As required for an award of “pre-issuance/provisional” damages,  
21 issued Claim 21 above is at the very least “substantially identical” to Claim 1 as  
22 published by the Patent Office in December 2013. Within both the letter and the  
23 spirit of 35 U.S.C. 154(d), the Court should award to Plaintiff pre-issuance  
24 damages for Defendants’ infringement occurring prior to actual issuance of the  
25 ‘852 patent.

26 133. Thus, the Patent Office published in 2013 a Claim 1 and subsequently  
27 issued that claim in “substantially identical” form, as Claim 21 in Plaintiff’s ‘852  
28

1 Patent.

2 134. The “substantially identical” requirement for pre-issuance damages is  
 3 also further met (for an additional one of Plaintiff’s ‘852 Patent claims) by the  
 4 Patent Office’s second publication of Plaintiff’s claims (in January 2018).  
 5 Specifically, in January 2018 the Patent Office published (among other claims) a  
 6 Claim 33. That Claim 33 subsequently issued as “substantially identical” Claim 1  
 7 in Plaintiff’s ‘852 Patent. Below is a table illustrating the very few differences in  
 8 the claim language, and that those differences are so minor that the claims already  
 9 are “substantially identical.” The yellow highlighting below shows the differences,  
 10 and therefore that the vast majority of the claims is **identical**. Those differences  
 11 are not material to any issues with respect to either (a) the validity of the claims  
 12 (both forms of the claim would be valid) and/or (b) infringement of the claim by  
 13 Defendants (Defendants’ poles infringe either and/or both forms of the claims):  
 14

<i>CLAIMS PUBLISHED 2018-01</i>	<i>ALLOWABLE CLAIMS 2021-06</i>
33. A telescoping pole apparatus, including:	33. An <b>elongated</b> telescoping pole apparatus, including:
an outer tube <b>and</b> an inner tube configured and sized to be slidable within said outer tube, said inner and outer tubes keyed to prevent relative rotation of the tubes with respect to each other around a central longitudinal axis through the tubes;	an <b>elongated</b> outer tube; an <b>elongated</b> inner tube configured and sized to be slidable within said outer tube; said inner and outer tubes keyed to prevent relative rotation of the tubes with respect to each other around a central longitudinal axis through the tubes;

<i>CLAIMS PUBLISHED 2018-01</i>	<i>ALLOWABLE CLAIMS 2021-06</i>
<p>said outer tube having first and second ends, said first end of said outer tube having a selectively actuatable detent configured to engage said inner tube at a selected position along the length of said inner tube, said second end of said outer tube having structure for removably attaching a tool;</p>	<p>said outer tube having first and second ends, said first end of said outer tube having a selectively actuatable detent configured to engage said inner tube at a selected position along the length of said inner tube, said second end of said outer tube having structure for removably attaching a tool;</p>
<p>said inner tube having first and second ends, said first end being received in said slidable relationship within said outer tube, said second end having a grip attached thereto, said selective sliding action of the tubes causing the respective distance between said grip on said inner tube and said actuatable detent on said first end of said outer tube to change.</p>	<p>said inner tube having first and second ends, said first end being received in said slidable relationship within said outer tube, said second end having a grip attached thereto, said selective sliding action of the tubes causing the respective distance between said grip on said inner tube and said actuatable detent on said first end of said outer tube to change;</p>
	<p>the lengths of said outer and inner tubes when engaged with each other being sufficient to permit a user gripping said first end of said inner tube to manipulate the swimming pool cleaning tool at the second end of said outer tube against the bottom of a swimming pool while the user is standing on the side of the pool.</p>

135. Still other facts support the award to Plaintiff of enhanced damages, attorneys fee, and pre-issuance damages. In mid-2021, the Patent Office Appeal Board ruled in Plaintiff’s favor regarding both of Plaintiff’s then-pending further pole applications.<sup>26</sup> Upon learning of those favorable rulings, rather than waiting

<sup>26</sup> One of those applications issued in October 2021, as Plaintiff’s ‘852 Patent (the patent upon which this lawsuit is focused). The Patent Office issued the other

1 to “surprise” Defendants with those patents after the patents issued, Plaintiff began  
2 efforts to try to reasonably resolve the related infringement issues between Plaintiff  
3 and Defendants (and other of the known infringers) many weeks before those two  
4 patents issued. Among other things, Plaintiff wrote to alert Defendants about the  
5 upcoming issuance of those patents, and invited settlement negotiations.  
6 Defendants’ actions in response to Plaintiff’s settlement efforts are further  
7 evidence supporting the additional awards of relief that the Court should make to  
8 Plaintiff and against Defendants.

9 136. Defendants’ responses followed the same pattern that Defendants had  
10 adopted in the parties’ 2018 lawsuit discussed above. For context, in the lead-up to  
11 the 2018 lawsuit, when Plaintiff’s principal Eric Resh confronted Defendants at the  
12 January 2018 trade show, Defendants told Mr. Resh (among other things) that the  
13 ‘458 Patent was invalid. When Plaintiff quickly sued Defendants, they never  
14 produced any evidence of invalidity of the ‘458 Patent. Instead, they removed the  
15 water channel feature so as to avoid infringing Plaintiff’s ‘458 Patent.

16 137. Similarly, when Plaintiff wrote to Defendants in 2021 about the  
17 upcoming issuance of Plaintiff’s ‘798 and ‘852 Patents, Defendants first addressed  
18 the ‘798 Patent (that the Patent Office scheduled to issue first), by alleging without  
19 any support<sup>27</sup> that prior art existed that would invalidate the ‘798 Patent. As the  
20 issue date drew nearer and Plaintiff remained unpersuaded by Defendants’  
21 allegations, Defendants (a) flooded the market with infringing poles, each having  
22

---

23 application to Plaintiff a few weeks earlier (in August 2021) as Plaintiff’s  
24 aforementioned ‘798 Patent (with claims primarily directed to multiple sets of tool  
attachment holes).

25 <sup>27</sup> Defendants did provide in letters unsupported “oral testimony” about  
26 alleged prior art (concerning multiple sets of attachment holes on a telescoping  
27 pole, a main focus of the ‘798 patent). As discussed in a separate section below,  
28 such oral testimony about alleged prior art is so untrustworthy that the Supreme  
Court and other courts have developed a black-letter rule holding that such  
evidence is insufficient as a matter of law.

1 the infringing ‘798 Patent’s multiple attachment holes, and (b) advised that  
2 Defendants were going to change all poles that they made and shipped after the  
3 ‘798 Patent issued, to remove that feature.<sup>28</sup> Again, as with the 2018 lawsuit,  
4 Defendants (a) alleged that Plaintiff’s patent was invalid, (b) failed to present any  
5 evidence to support such alleged invalidity, and (c) then removed the infringing  
6 feature.

7 138. Defendants’ tactics in the present dispute regarding Plaintiff’s current  
8 ‘852 Patent lawsuit are virtually identical (although there are some slight  
9 differences in timing). Despite having years of opportunity to find any invalidating  
10 prior art, and months of notice of the upcoming issuance of Plaintiff’s ‘852 Patent,  
11 Defendants waited until after the ‘852 Patent issued to provide Plaintiff with any  
12 defense to those charges of infringement. To this date, Defendants have never  
13 even argued that their poles do not infringe. However, almost a week after the  
14 ‘852 Patent issued, Defendants finally dragged out their old standby tactic:  
15 alleging unsupported oral testimony about alleged prior art that invalidates  
16 Plaintiff’s ‘852 Patent.<sup>29</sup> Perhaps Defendants will end up repeating their standard  
17 modus operandi (and eventually stop infringing, as they did with Plaintiff’s ‘458  
18 and ‘798 Patents), but to date Defendants have refused Plaintiff’s demands in that  
19 regard.

20 139. Analyzing the relevant factors and the facts outlined above and that  
21

22 <sup>28</sup> Plaintiff continues to consider suing Defendants for at least pre-issuance  
23 damages and/or injunctive relief for that infringement. However, that ‘798 Patent  
24 dispute involves a different patent and a different set of infringing products, among  
25 other things, so Plaintiff is not including it within the present Complaint.

26 <sup>29</sup> Plaintiff includes additional and more detailed allegations regarding this  
27 “A.G. Pro Pole” that allegedly was made and sold more than 20 years ago in the Los  
28 Angeles area (where Defendants and Plaintiff were and are actively involved in the  
swimming pool pole business). Defendants also alleged some other minor issues  
as possible defenses, and Defendants may assert those within this lawsuit, but as  
presently advised, none of those other points are meritorious and Plaintiff will  
address them if and when Defendants raise them.

1 Plaintiff will show at trial, the Court should award to Plaintiff (a) enhanced  
 2 damages, (b) reasonable attorney's fees, and (c) "provisional damages" (the latter  
 3 is for Defendants' infringement prior to issuance of Plaintiff's '852 Patent).

4 **DEFENDANTS' ALLEGED EVIDENCE OF PRIOR ART "A.G. PRO**  
 5 **POLE" IS INSUFFICIENT AS A MATTER OF LAW**

6 140. Resh realleges and incorporates by reference the allegations set forth  
 7 in paragraphs 1-147.

8 141. As noted above, Defendants very recently, and for the first time,  
 9 actually alleged specific prior art to try to invalidate Plaintiff's '852 Patent.<sup>30</sup> As  
 10 discussed below, Defendants made their allegations with only unsupported oral  
 11 testimonial evidence. As also set forth below, that evidence is insufficient as a  
 12 matter of law to support an allegation of prior art.

13 142. When Plaintiff asked Defendants for any evidence beyond that  
 14 unsupported oral testimony, Defendants indicated that Defendants have further  
 15 relevant information and/or evidence regarding that alleged prior art, but said that  
 16 Defendants are not willing to share that further information with Plaintiff. As a  
 17 consequence, Plaintiff is left to file this lawsuit, and use the Court and legal  
 18 processes such as discovery to obtain whatever further information or evidence  
 19 Defendants or third parties may have regarding Defendants' alleged prior art. If  
 20 Defendants instead had provided to Plaintiff their alleged "further evidence" about  
 21 the "prior art," this lawsuit may not have been necessary. This behavior by  
 22 Defendants is, by itself, a factor supporting the Court's award to Plaintiff of  
 23 attorney fees and/or other relief.

24 \_\_\_\_\_  
 25 <sup>30</sup> As noted above, in addition to Defendants' apparently "main" allegation of  
 26 invalidity based on the alleged "A.G. Pro Pole" (discussed herein), Defendants  
 27 have alleged a short list of other potential defenses, none of which appear to be of  
 28 much potential consequence. Those alleged defenses are such that Defendants  
 may not even include them as defenses in this lawsuit, but if Defendants do,  
 Plaintiff will address them at that time.



1 143. Plaintiff now alleges and sets forth further details regarding  
2 Defendants' very recent prior art allegations. As noted above, Defendants have  
3 been aware of Plaintiff's '852 Patent inventions for at least approximately 10  
4 years. During all of those years, until just a few months ago, Defendants (just like  
5 everyone else) had never mentioned any allegedly invalidating prior art regarding  
6 Plaintiff's pole inventions.

7 144. After Plaintiff's '852 Patent issued, and months after Plaintiff had  
8 alerted Defendants that the Patent Office was going to issue the '852 Patent,  
9 Defendants first mentioned something Defendants have called the "A.G. Pro Pole".

10 145. Upon receiving that allegation from Defendants, Plaintiff immediately  
11 and repeatedly requested all information or evidence Defendants have regarding  
12 that "A.G. Pro Pole." Among other things, Plaintiff wanted to make a good faith  
13 determination as to (a) whether that pole actually existed at any point in time prior  
14 to the filing date of Plaintiff's '852 patent, and (b) if so, the activities in which that  
15 pole was involved. In short, Plaintiff repeatedly requested that information, and  
16 although Defendants provided Plaintiff an opportunity to "inspect" that pole,  
17 Defendants did not provide any supporting evidence regarding the pole being  
18 "prior art," other than "oral testimony" that is legally insufficient as a matter of  
19 law, as explained below.

20 146. Broadly, based on the limited information that Defendants have  
21 provided to Plaintiff, Defendants assert that the "A.G. Pro Pole" existed circa 2000  
22 (more than 20 years ago), that it was publicly used and/or on sale within a period  
23 of approximately two years, and that it constitutes prior art that invalidates  
24 Plaintiff's '852 Patent. As further explained herein, Plaintiff is unpersuaded that  
25 Defendants' "A.G. Pro Pole" actually constitutes prior art with respect to  
26 Plaintiff's inventions. Plaintiff's doubt about the credibility of Defendants'  
27 allegations is based on many things (including ones discussed herein). Perhaps the  
28

1 most glaring of these reasons is Defendants’ refusal to share their alleged “prior  
2 use/sale evidence” more completely or confidently. In any case, because of  
3 Defendants’ refusals to be more forthcoming, Plaintiff is not currently able to  
4 reasonably further investigate the credibility of Defendants’ allegations.

5 147. Based on the “evidence” Defendants have provided to Plaintiff,  
6 Defendants’ main allegation relies virtually exclusively on oral testimony from  
7 one single person. That single witness is an alleged third-party pool man named  
8 Ray Leduc, who apparently alleges that he made prior use/sale of Plaintiff’s  
9 inventions, more than 20 years ago (more than 10 years before Plaintiff’s relevant  
10 filing date).

11 148. More specifically, Defendants have “shown” (but refused to give) to  
12 Plaintiff a single declaration of that one witness, Mr. Leduc. As also mentioned  
13 herein, Defendants have alleged orally that they have “further evidence,” but to  
14 date Defendants have refused to provide any of that “further evidence” to Plaintiff.

15 149. As explained below, Defendants’ allegations and single witness’ oral  
16 testimony are insufficient as a matter of law to establish invalidating prior art  
17 public use. According to the United States Supreme Court,<sup>31</sup> Defendants’ tactic  
18 has been very common since near the very beginning of our patent system. That  
19 “tactic” generally is as follows: in an effort to invalidate a patent, infringers  
20 commonly present one or more witnesses’ oral testimony about prior use/sale  
21 events that allegedly happened long ago, such as 20 or more years prior to the  
22 invention/patent and/or the dispute about the specific patent. Such “old oral prior  
23 art” tactics have not been well received by the courts. In fact, those tactics have  
24 resulted in the courts establishing a black-letter rule of law: such infringers are

---

25  
26 <sup>31</sup> See discussion below regarding *The Barbed Wire Patent* Supreme Court  
27 decision from 1892. The Supreme Court issued that decision 130 years ago, noting  
28 that even by that time, this tactic (alleging oral testimony of long-ago prior use of  
an invention) was a commonplace by patent infringers.

1 required to present sufficient corroboration, independent of the oral testimony, in  
2 order for the evidence to be persuasive. Said another way, without such  
3 corroboration, such “oral testimony” evidence is insufficient to invalidate a patent.

4 150. In the current case, Defendants have not provided the required  
5 corroborating evidence. In a section further below, Plaintiff details the “evidence”  
6 that Defendants have provided, and the strange/limited/dubious way in which  
7 Defendants have provided it.

8 151. First, however, to provide a frame of reference for (a) how  
9 commonplace this tactic is by infringers, and (b) courts’ alertness to and hesitancy  
10 to fall for such tactics, Plaintiff extensively discusses here a Supreme Court  
11 decision from 1892 dealing with such tactics/allegations. Following that  
12 discussion, and to show that this tactic is still in use by patent infringers (and still  
13 not welcomed by the courts), Plaintiff discusses in some detail a more recent 1999  
14 Federal Circuit decision (that cites extensively to the Supreme Court’s 1892  
15 decision).

16 **The Supreme Court’s 1892 “Corroboration Requirement”**

17 152. One hundred and thirty years ago, in *The Barbed Wire Patent*, 143  
18 U.S. 275, at 284-85, 12 S.Ct. 443, at 447 (1892), the Supreme Court dealt with  
19 patent infringers’ commonplace tactic of alleging “prior use” of the patented  
20 invention. In that *Barbed Wire Patent* case, several infringing fence sellers argued  
21 that the barbed wire patent was invalid because (among other things), several  
22 decades earlier (and before the inventor applied for a patent) **the invention**  
23 **allegedly had already been in use** by other barbed-wire producers. This is  
24 exactly what the current infringers Conrads/Skimlite apparently are attempting to  
25 do (with their Leduc declaration regarding an alleged “A.G. Pro Pole” allegedly in  
26 use several decades ago): they are presenting oral testimony about long-ago  
27  
28

1 activities, to allege that Plaintiff's pole inventions were already in use and on sale  
2 before Plaintiff's application.

3 153. It is informative to review (a) the evidence that the Supreme Court  
4 considered in the 1892 Barbed Wire Patent lawsuit, and (b) the comments the  
5 Supreme Court made in ruling that the evidence was not sufficient. According to  
6 the Supreme Court, The Barbed Wire Patent infringers submitted "... testimony ...  
7 tend[ing] to show the existence, public exhibition, and use of a number of [alleged  
8 prior art] fences prior to the date of the [patent] application..."

9 154. By way of comparison, and as more fully discussed below, the  
10 evidence submitted by The Barbed Wire Patent infringers in 1892 was much more  
11 substantial than the single witness submitted by current infringers  
12 Conrads/Skimlite allegations regarding the single alleged prior art "A.G. Pro Pole."  
13 In contrast to the current infringers' sole Leduc declaration, The Barbed Wire  
14 Patent infringers submitted evidence of a number of alleged prior art fences, and  
15 included twenty-four sworn witnesses regarding the alleged prior use of one of  
16 those fences, an alleged prior art "Morley Fence." Also in contrast to the current  
17 infringers' Leduc declaration, those Barbed Wire Patent witnesses were cross-  
18 examined by the patent owner (in the current status of the present case, Defendants  
19 Conrads/Skimlite will not even allow Plaintiff to have a copy of the Leduc  
20 declaration!).

21 155. As explained below, the Barbed Wire Patent case's numerous prior art  
22 fences and twenty-four witnesses were not enough to invalidate the barbed wire  
23 patent in 1892 – the Supreme Court held that Defendants' evidence did not  
24 invalidate that patent. Below is a further description of at least some of that  
25  
26  
27  
28

1 Barbed Wire Patent evidence held insufficient by the Supreme Court.<sup>32</sup> Plaintiff  
 2 submits that this detailed description will (a) even more clearly highlight the  
 3 deficiencies in Defendants' current "evidence" regarding the "A.G. Pro Pole," and  
 4 (b) underscore how important it is in these situations to focus on the details of the  
 5 evidence Defendants are offering as alleged prior art.

6 156. The patent application that was litigated in The Barbed Wire Patent  
 7 case was filed in 1873. In the subsequent lawsuit many years later, the 24  
 8 witnesses gave the following sworn testimony:

- 9
- 10 • that a panel of [the alleged prior art "Morley"] fence appears to have been  
 11 exhibited at a county fair in Delaware County, Iowa at Delhi, in 1858 and 1859;
- 12 • that at the time the fair was being held at Delhi [Iowa] in 1858 and 1859,  
 13 Morley came to the house of one Dubois, a farmer living in Delaware County,  
 14 having with him a piece of fence wire which had short pieces of wire wound  
 around it;
- 15 • that Morley remained with him that night; that the next day he saw a panel  
 16 of fence on the fairground exhibited by Morley, made by stretching wires from a  
 17 tree or post to another post, and that the wire so used was the same or similar to  
 that previously shown him by Morley;
- 18 • One Bates, a blacksmith, swore that he aided Morley in putting up the panel  
 19 of fence exhibited by him. He described the way the barbs were coiled around  
 20 the fence wire, testifying that he made the tools with which the short wires were  
 21 twisted around the fence wire, and describing the tools, and also that he  
 22 afterwards made a pair of shears for Morley to be used in cutting the wire into  
 pieces suitable for barbs;
- 23 • One Robinson, who acted as deputy marshal at the fair, testified that he rode  
 24 a gray horse, and, having occasion to leave him, hitched him to a fence post in  
 25 the fair-grounds, and on his return found his nose and breast bloody, caused by a  
 cut on his lip, and on examination found that the wires attached to the post had

26 <sup>32</sup> This description of the 24 witnesses' testimony here is either exactly  
 27 quoted from, or very closely based on, the Supreme Court's *Barbed Wire Patent*  
 28 opinion.

1 swags or barbs thereon, formed by coiling a short piece of wire around the fence  
2 wire;

3 • He also testified that in 1857, he was engaged in work on the railroad  
4 through Delaware County near which Morley had a piece of land; that Morley  
5 was frequently where witness was working, and tried to sell the land to him for a  
6 pair of mules, and that he had with him a piece of wire with swags on it, which  
7 he exhibited to witness, saying he was going to get it patented;

8 • There was other testimony to the effect that a boy, in playing with other boys  
9 on the fairgrounds, was thrown against the panel of fence and received two cuts,  
10 caused by the wires twisted upon the wire fence, which bled freely, and the scars  
11 of which were still visible upon his face;

12 • One Potter testified that he attended the fair and saw Morley there; that he  
13 exhibited a panel of fence made of wires strung between a tree and a post with  
14 barbs made of short wires twisted around the plain wire; that Morley gave him a  
15 piece of the wire with barbs on it; that he took it home with him; that he and his  
16 wife talked about it, and its effect upon stock; that he had the specimen of the  
17 wire in his summer kitchen for a year or more, and then put it in an old trunk in  
18 which he kept various relics and keepsakes; that it had remained there, and was  
19 there still, and then, on request of defendants' counsel, witness went to his  
20 home, brought the specimen of wire before the notary, and made it an exhibit in  
21 the case. It consists of a short piece of plain fence wire with two barbs on it,  
22 made by twisting other pieces of wire transversely around the fence wire;

23 • One Harrington also testified that he attended the fair; that he saw the panel  
24 of fence made of wire situated between a small tree and post and there were  
25 barbs on it made of short wires twisted around the fence wire; that his attention  
26 was attracted to it by efforts that were made to drive a bull upon it, and that he  
27 examined the wire, and noticed its construction.

28 • According to the recollection of some of the witnesses, it was made of three  
or four strands of single wire, on which the barbs were fastened, the wires being  
attached at their ends to posts in the ground, or to a post and a tree, and that the  
top wire had barbs on it formed of short pieces of wire wrapped around it, some  
say once, others twice, and still others three times. The other two or three strands  
of single wire were without barbs. Beneath the top barbed wire was a board to  
attract the attention of the cattle, either secured to the posts or suspended by a  
wire from the top wire strand. This fence was put up on the second day of the  
fair, and exhibited one day, as it appears the fair continued but two days. No one

1 seems to know what became of the panel nor of the barbed wire upon it. It was  
 2 never seen after the fair beyond the single piece produced by the witness Potter;

3 • It further appeared that in 1866, Morley took out a patent for a triangular  
 4 cattle pen built of posts and boards supported upon wheels, so constructed that it  
 5 could be moved by the animal inside of it. Some seven or eight witnesses  
 6 testified that at different times when they saw this machine, it had on it one or  
 7 more strands of fence wire with barbs or prickers on them, put on in the same  
 8 manner as were the barbs on the Delhi fair exhibit, and the whole strung on the  
 9 top of the posts above the boards;

10 • Other witnesses testified to seeing fences upon farms owned or occupied by  
 11 Morley, and in a yard near his mill, over which strands of barbed wire were  
 12 stretched in the same manner as in the Delhi fence;

13 • After discussing some of Defendants' evidence regarding other allegedly  
 14 prior art fences, the Court stated that, "There was a vast amount of [additional]  
 15 testimony of similar character tending to show the use of coiled barbs upon  
 16 [other] fence wires which it would serve no good purpose to discuss in detail."

17 157. The Supreme Court analyzed the foregoing infringers' evidence  
 18 (regarding the alleged prior art Morley fence), and held that the evidence was  
 19 **insufficient**:

20 "Even conceding that Morley did exhibit a wire fence armed  
 21 with barbs at the Delhi county fair, we do not think the testimony  
 22 connected with this fence makes out a case of prior use of the device  
 23 patented by Glidden, for the following reasons:

24 First. While the fence may have been armed with barbs,  
 25 there is very little if anything to show that it was constructed  
 26 according to the design of the Glidden fence. Indeed, after the  
 27 lapse of twenty-five years, it would in the nature of things be  
 28 highly improbable that any witness who saw this fence for the  
single day it was exhibited there would be able to describe it  
accurately.

Second. If Morley had regarded this fence as of any  
 value, he would have applied for a patent upon it, since he did  
 in fact obtain a patent for his traveling pen, which appears to

1 have been a comparatively worthless contrivance. If this pen  
2 had been armed with a barbed wire, it is somewhat singular that  
3 no allusion was made to it in the drawings or specification.

4 Third. The testimony of Potter that he preserved a piece  
5 of wire given to him by Morley in a trunk containing some old  
6 relies for over twenty-five years is not only contradicted by his  
7 son, who was familiar with the trunk, had examined its  
8 contents, and testified that he had never seen the wire there, but  
9 is improbable upon its face.

10 Fourth. If any experiments were made by Morley in this  
11 direction, they were evidently looked upon by him and by the  
12 public as of no practical value, and were subsequently  
13 abandoned, and the fences lost.

14 “While we think the testimony goes far to establish the fact that  
15 Morley exhibited a wire fence at this fair, and perhaps also used it  
16 upon his farm at about the date claimed, we are far from being  
17 satisfied that it was the Glidden device, or so near an approximation to  
18 it as to justify us in holding that it was an anticipation.”

19 (Emphasis added).

20 158. In its *Barbed Wire Patent* decision in 1892, the Supreme Court also  
21 noted the commonplace nature of the problem “with certain unpatented devices  
22 claimed to be complete anticipations of [a] patent, the existence and use of which  
23 are proven only by oral testimony.” The Supreme Court articulated some related  
24 general principles, including “**that [such evidence must] be subjected to the**  
25 **closest scrutiny**” because of “**the frequency with which testimony is tortured,**  
26 **or fabricated outright**”:

27 “In view of the **unsatisfactory character of such testimony,**  
28 arising from the forgetfulness of witnesses, their liability to mistakes,  
their proneness to recollect things as the party calling them would  
have them recollect them, aside from **the temptation to actual**  
**perjury,** courts have not only imposed upon defendants the burden of  
proving such devices, but have **required that the proof shall be**



1 clear, satisfactory and beyond a reasonable doubt. Witnesses  
 2 whose memories are prodded by the eagerness of interested parties to  
 3 elicit testimony favorable to themselves are not usually to be  
 4 depended upon for accurate information. The very fact, which courts  
 5 as well as the public have not failed to recognize, that almost every  
 6 important patent, from the cotton gin of Whitney to the one under  
 7 consideration, has been attacked by the testimony of witnesses  
 8 who imagined they had made similar discoveries long before the  
 9 patentee had claimed to have invented his device, has tended to throw  
 10 a certain amount of discredit upon all that class of evidence, and to  
 11 demand that it be subjected to the closest scrutiny. Indeed, the  
 12 frequency with which testimony is tortured, or fabricated  
 13 outright, to build up the defense of a prior use of the thing patented,  
 14 goes far to justify the popular impression that the inventor may be  
 15 treated as the lawful prey of the infringer. The doctrine was laid down  
 16 by this court in *Coffin v. Ogden*, 18 Wall. 120, 124 [21 L.Ed. 821, 85  
 17 U.S. 120 (1873)], that:

18 “the burden of proof rests upon him, the  
 19 defendant, and every reasonable doubt should be  
 20 resolved against him. If the thing were embryotic or  
 21 inchoate; if it rested in speculation or experiment; if the  
 22 process pursued for its development had failed to reach the  
 23 point of consummation, it cannot avail to defeat a patent  
 24 founded upon a discovery or invention which was  
 25 completed, while in the other case there was only progress,  
 26 however near that progress may have approximated to the  
 27 end in view.”

28 (Emphasis added).

159. Finally, and as noted above, the Supreme Court held that the  
 foregoing oral/other testimony did not invalidate the Barbed Wire Patent,  
 concluding (in language that appears to likewise apply to Plaintiff’s inventions and  
 the great public reception and copying by competitors of Plaintiff’s inventions):

“...There was evidently, prior to [the patentee] Glidden’s  
 application, more or less experimenting in a rude way, in or about  
 Delaware county, upon the subject of barbed wires as applied to wire

1 fences, and we think it is quite probable that coiled barbs were affixed  
 2 to single wires before the Glidden application was made. We are not  
 3 satisfied, however, that he was not the originator of the combination  
 4 claimed by him of the coiled barb, locked and held in place by the  
 5 intertwisted wire. It is possible that we are mistaken in this; that some  
 6 one of these experimenters may have, in a crude way, hit upon the  
 7 exact device patented by Glidden, although we are not satisfied from  
 8 this testimony whether or by whom it was done. It is quite evident too  
 9 that all or nearly all these experiments were subsequently abandoned.  
 10 But it was Glidden beyond question who first published this  
 11 device, put it upon record, made use of it for a practical purpose,  
 12 and gave it to the public, by which it was eagerly seized upon and  
 13 spread until there is scarcely a cattle-raising district in the world in  
 14 which it is not extensively employed. Under these circumstances, we  
 15 think the doubts we entertain concerning the actual inventor of this  
 16 device should be resolved in favor of the patentee.”

17 (Emphasis added).

18 160. The record in this application and its parent applications/prosecutions  
 19 show that, like the patentee in *The Barbed Wire Patent*, Plaintiff was the first to  
 20 have “**published this [current pool pole] device, put it upon record, made use**  
 21 **of it for a practical purpose, and gave it to the public, by which it was eagerly**  
 22 **seized upon and spread...”**

23 161. Thus, the Conrads/Skimlite infringers’ tactic of “old public use”  
 24 evidence has been plaguing patent law for hundreds of years. As further discussed  
 25 herein, that abusive tactic has led to an absolute requirement that such testimony be  
 26 sufficiently **corroborated**. In the present situation, and as explained further  
 27 below, the Conrads/Skimlite infringers have not provided any corroboration to  
 28 establish any relevant activity (by Mr. Leduc or anyone). Mr. Leduc’s “oral  
 testimony” declaration is the only evidence Defendants have presented. The  
 documents attached to Mr. Leduc’s declaration have to do with existing generic  
 and commercially available things, not having anything to do with combining

1 those things in any manner, let alone to make Plaintiff's inventions. Those generic  
2 things include:

3 (a) pool pole replacement parts (grips and aluminum adapters for all-  
4 fiberglass twist-lock poles), things that any pool man might have; and

5 (b) painters poles (painters poles that Plaintiff already made of record  
6 in prosecuting Plaintiff's '852 patent, over which the Patent Office granted  
7 Plaintiff's '852 patent).  
8

9 Again, the Conrads/Skimlite infringers have not presented any corroborating  
10 evidence of Mr. Leduc or anyone combining those generic things at any point in  
11 time that would qualify as prior art with respect to Plaintiff's inventions.

12 **The Federal Circuit's Related 1999 "Corroboration Requirement" in**  
13 **Finnigan Corp.: "Oral Testimony is Peculiarly UNTRUSTWORTHY"**

14 162. Since that 1892 Supreme Court *The Barbed Wire Patent* case,  
15 additional court decisions have extensively discussed the high threshold for  
16 corroboration of oral testimony about alleged "prior use" of a patented invention.  
17 One such case is *Finnigan Corp. v. Int'l Trade Comm'n*, 180 F. 3d 1354 (Fed. Cir.  
18 1999), a case that is perhaps even more factually similar to the present infringers'  
19 alleged "A.G. Pro Pole" prior art. In *Finnigan*, the Federal Circuit cited the  
20 Supreme Court's *The Barbed Wire Patent* decision extensively, and relied upon the  
21 principles from the Supreme Court to again find that the "oral testimony" of  
22 invalidating prior art was **not** sufficient.

23 163. To permit convenient comparison of the present "A.G. Pro Pole"  
24 allegations with the facts of the Federal Circuit's *Finnigan* decision, Plaintiff  
25 quotes and highlights *Finnigan* at length below:  
26

27 As we have had occasion before to observe, oral testimony,  
28 unsupported by patents or exhibits, tending to show prior use of a

1 device regularly patented, is, in the nature of the case, open to grave  
2 suspicion. *The Barbed Wire Patent*, 143 U.S. 275, 12 S.Ct. 443, 36  
3 L.Ed. 154 [(1892)]. Granting the witnesses to be of the highest  
4 character, and never so conscientious in their desire to tell only the  
5 truth, the possibility of their being mistaken as to the exact device  
6 used, which, though bearing a general resemblance to the one  
7 patented, may differ from it in the very particular which makes it  
8 patentable, is such as to **render oral testimony peculiarly**  
9 **untrustworthy; particularly so if the testimony be taken after the**  
10 **lapse of years from the time the alleged anticipating device was**  
11 **used.** If there be added to this a personal bias, or an incentive to color  
12 the testimony in the interest of the party calling the witness, to say  
13 nothing of downright perjury, its value is, of course, still more  
14 seriously impaired.

15 ...

16 The law has long looked with disfavor upon invalidating  
17 patents on the basis of mere testimonial evidence absent other  
18 evidence that corroborates that testimony. The Supreme Court  
19 recognized over one hundred years ago that testimony concerning  
20 invalidating activities can be “unsatisfactory” due to “the  
21 forgetfulness of witnesses, their liability to mistakes, their proneness  
22 to recollect things as the party calling them would have them recollect  
23 them, aside from the temptation to actual perjury.” *The Barbed Wire*  
24 *Patent*, 143 U.S. 275, 284, 12 S.Ct. 443, 36 L.Ed. 154 (1891).  
25 Accordingly, “[w]itnesses whose memories are prodded by the  
26 eagerness of interested parties to elicit testimony favorable to  
27 themselves are not usually to be depended upon for accurate  
28 information,” and therefore such testimony rarely satisfies the burden  
upon the interested party, usually the accused infringer, to prove  
invalidity by clear and convincing evidence.

**Mere testimony concerning invalidating activities is**  
**received with further skepticism because such activities are**  
**normally documented by tangible evidence such as devices,**  
**schematics, or other materials** that typically accompany the  
inventive process. See *Woodland Trust v. Flowertree Nursery, Inc.*,  
148 F.3d 1368, 1373, 47 USPQ2d 1363, 1367 (Fed.Cir.1998) (noting  
that the skepticism with which mere testimony of invalidating activity  
is received is “reinforced, in modern times, by the ubiquitous paper

1 trail of virtually all commercial activity. It is rare indeed that some  
2 physical record (e.g., a written document such as notes, letters,  
3 invoices, notebooks, or a sketch or drawing or photograph showing  
4 the device, a model, or some other contemporaneous record) does not  
5 exist.”); *Eibel Process Co. v. Minnesota & Ontario Paper Co.*, 261  
6 U.S. 45, 60, 43 S.Ct. 322, 67 L.Ed. 523 (1923) (holding that the oral  
7 testimony of prior public use “falls short of being enough to overcome  
8 the presumption of novelty from the granting of the patent” when  
9 “there is not a single written record, letter or specification of prior  
10 date to [the patentee’s] application that discloses any such discovery  
11 by anyone....”).

12 While this court has in the past applied the requirement of  
13 corroboration more often in the context of priority disputes under 35  
14 U.S.C. § 102(g), [fn. omitted] corroboration has been required to  
15 prove invalidity under other subsections of § 102 as well. [fn.  
16 omitted] In the context of § 102(f) (derivation) and § 102(g) (priority),  
17 we have stated that “the case law is unequivocal that an inventor’s  
18 testimony respecting facts surrounding a claim of derivation or  
19 priority of invention cannot, standing alone, rise to the level of clear  
20 and convincing proof.” *Price v. Symsek*, 988 F.2d 1187, 1194, 26  
21 USPQ2d 1031, 1036 (Fed.Cir.1993). No principled reason appears  
22 for applying a different rule when other subsections of § 102 are  
23 implicated: **a witness’s uncorroborated testimony is equally**  
24 **suspect as clear and convincing evidence if he testifies concerning**  
25 **the use of the invention in public before invention by the patentee**  
26 **(§ 102(a)), use of the invention in public one year before the**  
27 **patentee filed his patent (§ 102(b)), or invention before the**  
28 **patentee (§ 102(g)).**

...

22 Moreover, the need for corroboration exists regardless of  
23 whether the party testifying concerning the invalidating activity is  
24 interested in the outcome of the litigation (e.g., because that party is  
25 the accused infringer) or is uninterested but testifying on behalf of an  
26 interested party. That corroboration is required in the former  
27 circumstance cannot be debated. *See, e.g., Stevenson v. International*  
28 *Trade Comm’n*, 67 C.C.P.A. 109, 612 F.2d 546, 550, 204 USPQ 276,  
280 (CCPA 1979) (“Uncorroborated oral testimony of prior inventors  
or users with a demonstrated financial interest in the outcome of the

1 litigation is insufficient to provide such proof.”). Uninterested  
2 witnesses are also subject to the corroboration requirement. For  
3 example, in *Barbed Wire Patent*, some twenty-four witnesses, all  
4 apparently uninterested in the outcome of the case, testified on behalf  
5 of the accused infringer that they had seen the patented fence  
6 exhibited by a third party, Mr. Morley, at a county fair more than two  
7 years prior to the filing of the patent. *See Barbed Wire Patent*, 143  
8 U.S. at 286-87. That the witnesses themselves were not interested did  
9 not immunize their testimony from the corroboration requirement.  
10 *See Barbed Wire*, 143 U.S. at 284 (“[w]itnesses whose memories are  
11 prodded by the eagerness of interested parties to elicit testimony  
12 favorable to themselves are not usually to be depended upon for  
13 accurate information.”) (emphasis added). It is not surprising that the  
14 cases have held that testimony concerning a witness’s own  
15 anticipatory activities must be corroborated. A witness who testifies  
16 to antedating the invention of the patent-in-suit can be expected to  
17 derive a sense of professional or personnel accomplishment in being  
18 the first in the field, and in this sense is not uninterested in the  
19 outcome of the litigation, even if that witness is not claiming  
20 entitlement to a patent. Of course, the need for corroboration takes on  
21 special force when an otherwise uninterested witness shows some  
22 reason to be biased in favor of the interested party.

23 ...

24 In the final analysis, **the Supreme Court has defined the**  
25 **necessity of corroboration** not with reference to the level of interest  
26 of the testifying witness, but rather **because of doubt that**  
27 **testimonial evidence alone in the special context of proving patent**  
28 **invalidity can meet the clear and convincing evidentiary standard to**  
**invalidate a patent.**

...

*See Woodland Trust*, 148 F.3d ... at 1373, 47 USPQ2d at 1368  
 (“The relationship of the witnesses and the fact that the asserted prior  
uses ended twenty years before the trial, and were abandoned until the  
defendant reportedly learned of the patentee’s practices, underscore  
the failure of this oral evidence to provide clear and convincing  
evidence of prior knowledge and use.”). Cases like *Thomson* and  
*Woodland Trust* correctly recognized that the level of interest of the

1           testifying witness is an important consideration when such testimony  
2           is offered to corroborate another witness's testimony.

3           ...

4           2. Jefferts' Alleged Public Use

5           Jefferts' testimony that he used the claimed invention more than  
6           one year prior to the filing of the '884 patent was not corroborated by  
7           other evidence. The Jefferts' article simply does not corroborate his  
8           testimony because, as we have noted, that article is ambiguous at best  
9           concerning the claimed use of nonresonance ejection. Similarly, other  
10          testimony taken before the Commission was relevant only to whether  
11          Jefferts' experiments were sufficiently public to constitute public use.

12          ...

13          In this case, **the sole basis to support a determination of a**  
14          **prior public use was Jefferts' testimony concerning his own work;**  
15          **there was no evidence corroborative of this testimony at all...**

16          ...

17          In the end, **what we are left with is Jefferts' testimony**  
18          **concerning his alleged public use. Such evidence is insufficient as a**  
19          **matter of law to establish invalidity of the patent.** This is not a  
20          judgment that Jefferts testimony is incredible, but simply that such  
21          testimony alone cannot surmount the hurdle that the clear and  
22          convincing evidence standard imposes in proving patent invalidity.  
23          *See Mahurkar v. C.R. Bard, Inc.*, 79 F.3d 1572, 1577, 38 USPQ2d  
24          1288, 1291 (Fed.Cir.1996) (noting that the corroboration rule,  
25          "provides a bright line for both district courts and the PTO to  
26          follow....").

27          *Finnigan Corp. v. Int'l Trade Comm'n*, 180 F. 3d 1354 (Fed. Cir. 1999)  
28          (emphasis added).

164. In many ways, the facts in the *Finnigan* case are very similar to those  
of the present "A.G. Pro Pole" situation. As further discussed below, the  
Conrads/Skimlite infringers' current declarant (Mr. Leduc) is providing oral  
testimony (via his declaration) about events that occurred **over two decades ago**

1 (years 2000-2002). He is making those oral allegations **without** corroboration. In  
 2 addition, it seems at least possible that Mr. Leduc may have a friendship or  
 3 acquaintance with Defendants Conrads/Skimlite or otherwise be biased in the  
 4 interest of Defendants.<sup>33</sup> As discussed below (and as in the *Eibel* case cited  
 5 above), Defendants Conrads/Skimlite have not produced “a single written record,  
 6 letter or specification of prior date to [Plaintiff’s] application that discloses any  
 7 such discovery by anyone.” Instead, the Leduc “corroborating evidence” consists  
 8 of existing generic components that Mr. Leduc allegedly purchased (painters’  
 9 poles, and grips and aluminum adapters for all-fiberglass pool poles). Defendants  
 10 have provided **no** evidence that Mr. Leduc (or anyone) actually assembled,  
 11 publicly used, sold, or even offered for sale, the allegedly fully-assembled “A.G.  
 12 Pro Pole” from those components. Thus, the current situation appears to fit  
 13 squarely within those cases described above, involving “doubt that testimonial  
 14 evidence alone in the special context of proving patent invalidity can meet the clear  
 15 and convincing evidentiary standard to invalidate a patent.”

16 **Examples of Other “Corroborating Evidence” Court Decisions**

17 165. Below are excerpts from some of the many other decisions on this  
 18 topic (of the burden on infringers to invalidate a patent based on alleged prior use).  
 19 Some of these decisions were cited in the *Finnigan* decision above, and Plaintiff  
 20 attempts here to provide at least some further relevant details, for purpose of  
 21 comparison to the present “A.G. Pro Pole” allegations:  
 22  
 23  
 24

25 <sup>33</sup> Again, Applicant may have the opportunity to further explore these facts  
 26 and evidence in any litigation between the parties. As discussed below, however,  
 27 it seems clear that Mr. Leduc lived and worked near the Conrads for many years,  
 28 north of Los Angeles, California. Perhaps more importantly, if Mr. Leduc were  
**not** acquainted with the Conrads, one is left to wonder how the Conrads were able  
 to locate him and elicit his recent declaration.



- 1 • *Eibel Process Co. v. Minnesota & Ontario Paper Co.*, 261 U.S. 45, 60, 43  
 2 S.Ct. 322, 67 L.Ed. 523 (1923) (holding that the oral testimony of prior  
 3 public use “falls short of being enough to overcome the presumption of  
 4 novelty from the granting of the patent” when “**there is not a single written  
 5 record, letter or specification of prior date to [the patentee’s]  
 6 application that discloses any such discovery by anyone....** The oral  
 7 evidence on this point falls far short of being enough to overcome the  
 8 presumption of novelty from the granting of the patent. **The temptation to  
 9 remember in such cases and the ease with which honest witnesses can  
 10 convince themselves after many years of having had a conception at the  
 11 basis of a valuable patent, are well known in this branch of the law, and  
 12 have properly led to a rule that evidence to prove prior discovery must  
 13 be clear and satisfactory.”)**
- 14 • *Woodland Trust v. Flowertree Nursery, Inc.*, 148 F.3d 1368, 1371-1373, 47  
 15 USPQ2d 1363, 1367 (Fed.Cir.1998) (“**there is a very heavy burden to be  
 16 met by one challenging validity when the only evidence is the oral  
 17 testimony of interested persons and their friends,<sup>34</sup> particularly of long-  
 18 past events;**” noting that **the skepticism with which mere testimony of  
 19 invalidating activity is received** is “reinforced, in modern times, by the  
 20 ubiquitous paper trail of virtually all commercial activity. **It is rare indeed  
 21 that some physical record (e.g., a written document such as notes,  
 22 letters, invoices, notebooks, or a sketch or drawing or photograph  
 23 showing the device, a model, or some other contemporaneous record)  
 24 does not exist... The relationship of the witnesses and the fact that the  
 25 asserted prior uses ended twenty years before the trial, and were  
 26 abandoned until the defendant reportedly learned of the patentee’s  
 27 practices, underscore the failure of this oral evidence to provide clear  
 28 and convincing evidence of prior knowledge and use.”)**
- *Price v. Symsek*, 988 F.2d 1187, 1195, incl. at fn. 3 (Fed. Cir. 1993): “An  
 evaluation of all pertinent evidence must be made so that **a sound  
 determination of the credibility of the ... story** may be reached. The  
**factors bearing on that credibility** which must be considered are unrelated  
 to the existence of the patent and include:
- (1) **delay** between event and trial,
  - (2) **interest of witness,**

<sup>34</sup> See preceding footnote regarding likelihood that infringers  
 Conrads/Skimlite are at least acquainted with declarant Ray Leduc.

- (3) contradiction or impeachment,
- (4) **corroboration**,
- (5) witnesses' familiarity with details of alleged prior structure,
- (6) improbability of prior use considering state of the art,
- (7) **impact of the invention on the industry**, and
- (8) **relationship between witness and alleged prior user.**<sup>35</sup>

(Emphasis added).

**Defendants' "A.G. Pro Pole" Allegations Do Not Meet the Very High "Corroboration Requirement" Burden of Proof for Such Alleged Prior Use**

166. Within the foregoing legal framework of *The Barbed Wire Patent* and *Finnigan* decisions and related cases, Plaintiff now discusses Defendants' alleged "evidence" regarding the "A.G. Pro Pole." As mentioned above, in response to Plaintiff's pursuit of certain infringers of Plaintiff's recently-issued '852 patent, some of Defendants (the Conrads and their company, Skimlite) have recently alleged that an "A.G. Pro Pole" is invalidating prior art with respect to Plaintiff's '852 patent. As discussed below, those allegations do not appear (to Plaintiff) to be credible, and certainly not to be sufficient or persuasive in overcoming the foregoing high burden that Defendants are required to meet in order to invalidate Plaintiff's '852 Patent claims.

167. In addition to (and independently of) the actual deficient substance of the Conrads/Skimlite infringers' "A.G. Pro Pole" allegations, Defendants presented their allegations to Plaintiff in a very strange and even paranoid way. Defendants' actions were so strange that those actions themselves at least arguably cast doubt

---

<sup>35</sup> These *Price* factors, including especially the highlighted ones, seem directly applicable to Applicant's current pole inventions and the infringers' related "A.G. Pro Pole" "evidence."

1 on the credibility of Defendants’ “A.G. Pro Pole” allegations – it is as if  
2 Defendants themselves do not believe the allegations.

3 168. Below are descriptions of (a) some of Defendants’ strange behavior  
4 regarding their alleged “A.G. Pro Pole” prior art, and (b) the insufficient  
5 “evidence” that Defendants have chosen to make available to Plaintiff.

6 169. Plaintiff has been in disputes with Conrads/Skimlite for several years  
7 regarding Defendants’ infringing products. Plaintiff even sued Defendants and  
8 forced them to change their poles (in 2018). As Plaintiff’s further pole patents  
9 were finally/recently allowed, Plaintiff actively began further negotiations with  
10 infringers Conrads/Skimlite regarding Plaintiff’s upcoming ‘852 patent and  
11 another related pole patent. Plaintiff began these negotiations before either of  
12 those patents had even issued (as early as July 1, 2021). In that regard, and for  
13 convenient reference, below is a copy of the first part of Plaintiff’s attorney’s July  
14 1, 2021 letter to Defendants’ attorneys, directed to the upcoming issuance of both  
15 of those pole patents:<sup>36</sup>

16  
17  
18  
19  
20  
21  
22  
23  
24  
25  
26 \_\_\_\_\_  
27 <sup>36</sup> Because the ‘852 patent had not yet issued or been assigned a patent  
28 number, the letter below references Applicant’s patent application Ser. No.  
15/708,038 (which eventually issued as Applicant’s ‘852 patent).

J. MARK HOLLAND & ASSOCIATES

19800 MACARTHUR BLVD., SUITE 300  
IRVINE, CALIFORNIA 92612

TELEPHONE: (949) 718-6750

FACSIMILE: (949) 718-6756

E-MAIL: office@jmhlaw.com

PATENT, TRADEMARK, COPYRIGHT,  
AND RELATED MATTERS

J. MARK HOLLAND, PC

July 1, 2021

Via Email

John Sganga, Esq. ([john.sganga@knobbe.com](mailto:john.sganga@knobbe.com))  
Joshua Stowell, Esq. ([Joshua.Stowell@knobbe.com](mailto:Joshua.Stowell@knobbe.com))  
Knobbe Martens  
2040 Main Street, 14th Floor  
Irvine, California 92614

Re: Your Clients Skimlite Manufacturing, Inc. and James and  
Barrett Conrad, and Their Pool Poles Having (a) Lever  
Locking and/or (b) Multiple Attachment Hole Features;

Infringement of and Related Damages Based on Resh's  
Recently Allowed Rights in U.S. Patent Application Ser.  
Nos. 13/844,561 and 15/708,038;

Our Files: RESH-L4084; -P3841.3; -P3841.4

Dear Messrs. Sganga and Stowell:

As you will recall, we represent Eric and Jenel Resh and their companies in intellectual property matters. Because this communication relates at least generally to the 2018 litigation between (a) our clients and (b) Skimlite Manufacturing, Inc. and James and Barrett Conrad (in which you represented Skimlite and the Conrads), we are directing this communication to you in the first instance. If you no longer represent those parties (or do not represent them regarding this current matter), please advise and we instead will communicate directly with Skimlite Manufacturing, Inc. and James and Barrett Conrad.

170. Defendants did not respond to the above July 1 letter. Accordingly, Plaintiff sent further notice letters on July 9 and July 14, and finally Defendants' attorneys responded on July 16. Notably, however, Defendants' response did **not** address Plaintiff's upcoming '852 patent, but instead was directed to the other of Plaintiff's recent related patents.<sup>37</sup> Rather than even mentioning any "A.G. Pro Pole," Defendants July 16 letter only addressed Plaintiff's other recent patent, and

<sup>37</sup> U.S. Pat. No. 11,090,798 (from Ser. No. 13/844,561 above), directed to multiple pairs of tool attachment holes.

1 stated that Defendants were immediately changing their poles to avoid  
 2 infringement (this did not resolve the issue of pre-issuance damages for infringing  
 3 that other patent, an issue that is still unresolved). Below is a portion of that July  
 4 16 response from infringers’ attorneys (again, directed to Plaintiff’s other recent  
 5 pole patent, not to Plaintiff’s ‘852 patent):

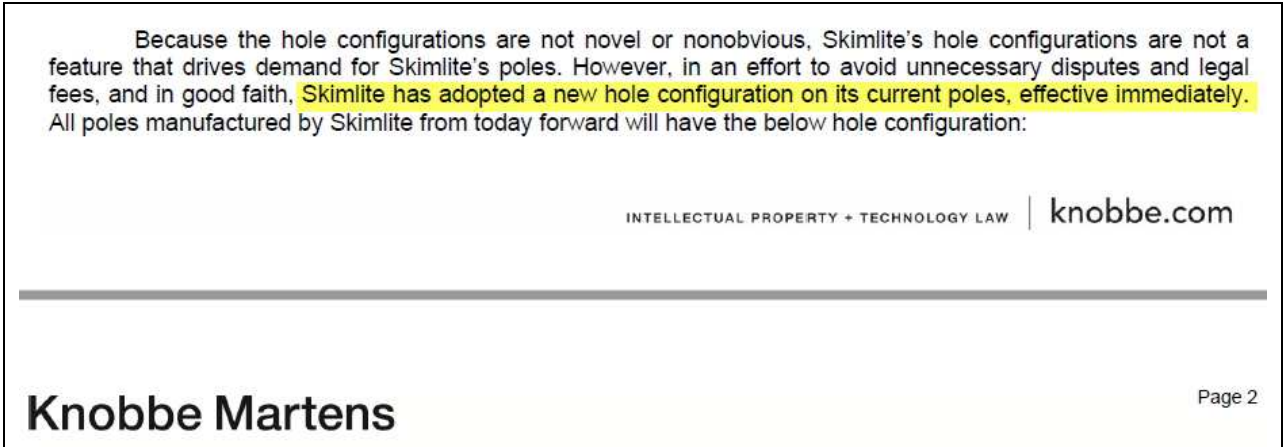

13  
 14  
 15 171. In that July 16 response, regarding Plaintiff’s upcoming ‘852 patent  
 16 (which issued from patent application Ser. No. 15/708,038), instead of mentioning  
 17 any alleged “A.G. Pro Pole” prior art, Defendants simply stated that they were  
 18 “continuing to investigate” that infringement. Below is a screenshot of infringers’  
 19 terse July 16 statement:



1  
2  
3 172. Following Defendants' response on July 16 (with no mention of any  
4 "A.G. Pro Pole"), the parties exchanged several further written communications,  
5 but Defendants had not stopped infringing Plaintiff's '852 patent by the time the  
6 patent issued (on October 12, 2021). Perhaps more importantly, during those  
7 further communications, the Conrads/Skimlite infringers had not mentioned  
8 anything about an "A.G. Pro Pole."

9 173. Finally, in a letter dated October 18, 2021, **more than three-and-one-**  
10 **half months after Plaintiff sent the July 1, 2021 letter** advising that the '852  
11 patent was about to issue, the Conrads/Skimlite infringers first mentioned an  
12 alleged prior art "A.G. Pro Pole." As further discussed below, this was nearly **a**  
13 **week after Plaintiff's '852 patent issued.** Infringers' October 18, 2021 letter was  
14 the first time Plaintiff had ever heard of anything called an "A.G. Pro Pole," and/or  
15 had ever heard about or seen the pole shown in the pictures within that letter. To  
16 provide even further context, and as established in Plaintiff's parent '852 file  
17 history, Defendants Conrads/Skimlite had known of Plaintiff's swimming pool  
18 pole inventions and patents and applications **for nearly ten years.** During all of  
19 that time, including during the 2018 lawsuit by which Plaintiff sued Defendants,  
20 Defendants had not mentioned anything about any alleged prior art "A.G. Pro  
21 Pole."

22 174. In addition to the strange/extraordinary **delay** in advising Plaintiff of  
23 the alleged prior art "A.G. Pro Pole," the **content** of the Conrads/Skimlite  
24 attorneys' October 18 letter itself is notably strange and unusual. Among other  
25 things, Defendants' attorneys spend virtually all of their October 18, 2021 letter  
26 discussing the **features** of that alleged "A.G. Pro Pole." They do **not** present **any**  
27 evidence to support their assertions that the "A.G. Pro Pole" *actually was prior art*  
28 with respect to Plaintiff's pole inventions. As a result of that complete absence of

1 evidence, and for all that Plaintiff or anyone else could tell, Defendants  
2 Conrads/Skimlite may have just assembled that “A.G. Pro Pole” on the same day  
3 that the October 18, 2021 letter was sent!

4 175. In that regard, Plaintiff has highlighted below in yellow the few and  
5 unsupported assertions by those attorneys. The attorneys (not even Defendants  
6 Conrads/Skimlite themselves) assert without support that the “A.G. Pro Pole” **is**  
7 prior art. Those attorneys simply make that naked assertion a single time on page  
8 2, and again a single time on page 4 (see below portions of pages 2-4 of  
9 Defendants’ attorneys’ October 18 letter):

10  
11  
12  
13  
14  
15  
16  
17  
18  
19  
20  
21  
22  
23  
24  
25  
26  
27  
28

1        **C.    The Claims of the '852 Patent Are Anticipated Or Obvious**

2        All the claims of the '852 patent are invalid as anticipated under 35 U.S.C. § 102 or obvious  
3        under 35 U.S.C. § 103 in view of the prior art. Please note that Skinlite has not completed its  
4        investigation into prior art related to the '852 patent and anticipates that further prior art will come to  
5        light in any litigation involving the '852 patent. The below-identified art is merely exemplary and is not  
6        intended to exhaustively describe all prior art.

7                                **1.    The A.G. Pro Pole Anticipates or Renders Obvious Every Claim**

8        The claims of the '852 patent are anticipated or rendered obvious by the below-pictured A.G.  
9        Pro Pole, which was publicly used, publicly known, and sold in the United States at least as early as  
10       2001. The A.G. Pro Pole is an elongate telescoping pole apparatus for cleaning swimming pools.



The A.G. Pro Poles were manufactured by modifying commercially-available telescoping poles sold by Mr. Longarm. The Mr. Longarm logo remains visible on the detent mechanism of the A.G. Pro Pole:



The A.G. Pro Poles include an elongate outer tube and an elongate inner tube configured and sized to be slidable within said outer tube. As shown in the figure below, the inner and outer tubes are "keyed" to prevent relative rotation of the tubes with respect to each other around a central longitudinal axis through the tubes.



## Knobbe Martens

Page 3



Also shown in the figure above, the outer tube includes a collar that further comprises a “selectively actuatable detent” configured to engage the inner tube at a selected position along the length of said inner tube. As further shown below, the other end of the outer tube has “structure for removably attaching a tool.”



As shown below, the inner tube has first and second ends where the first end is received in said slidable relationship within said outer tube and the second end has a grip attached thereto.



Moreover, the selective sliding action of the tubes causes the respective distance between said grip on said inner tube and said actuatable detent on said first end of said outer tube to change.

The A.G. Pro Pole was not disclosed to the Examiner of the '852 patent during examination. While a patent assigned to Mr. Longarm (U.S. Pat. No. 5,220,707, referred to as “Longarm Patent”) was discussed in the '852 patent’s specification and prosecution history, the A.G. Pro Pole has different features that distinguish it from the poles disclosed in the Longarm Patent. Notably, the A.G. Pro Pole is strikingly similar to Figure 1 of the '852 patent.

## Knobbe Martens

Page 4

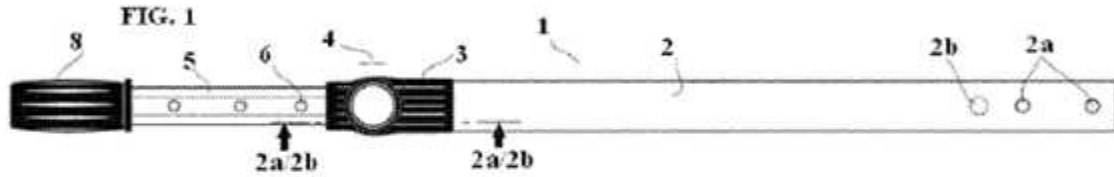

8

9

10

11

12

The A.G. Pro Pole is prior art under 35 U.S.C. § 102(b) and anticipates or renders obvious every claim of the '852 patent. To the extent the A.G. Pro Pole alone does not anticipate or render obvious any claim, it would have been obvious to modify the A.G. Pro Pole to include the allegedly missing features in view of known art in the pool pole field. Specifically, with regard to Claim 20, telescoping poles including an "intermediate pole" were well known in the art long before the filing of the '852 patent, as the patentee admitted in the '852 patent. *E.g.*, U.S. Pat. 3,407,424. It would have been obvious to include an "intermediate tube," as described in claim 20, with the A.G. Pro Pole. Accordingly, every claim of the '852 patent is invalid as anticipated or obvious in view of the A.G. Pro Pole.

13

14

15

16

17

18

176. As shown in the highlighted text above, infringers Conrads/Skimlite simply asserted (**without any supporting evidence**) that the A.G. Pro Pole "was publicly used, publicly known, and sold in the United States at least as early as 2001",<sup>38</sup> and that the "A.G. Pro Pole **is** prior art" with respect to Plaintiff's '852 inventions.<sup>39</sup>

19

20

21

22

23

24

25

177. It seems strange that such "prior art" allegations would be sent without **any** corroborating evidence. It seems **especially** strange that a prestigious patent law firm, and its very seasoned and experienced patent litigation partners, would send such a letter with no supporting evidence. Without any such corroborating evidence, how could anyone receiving or reviewing their letter have any sense that the "A.G. Pro Pole" had in fact **existed** prior to October 18, 2021?

26

27

<sup>38</sup> Page 2 of their October 18, 2021 letter.

<sup>39</sup> Page 4 of their October 18, 2021 letter; emphasis added.

1           178. In any case, given Defendants’ failure to present any corroborating  
2 evidence that the “A.G. Pro Pole” was in fact prior art, and given that Plaintiff had  
3 never heard of the “A.G. Pro Pole,” and given Plaintiff’s previous experiences with  
4 the Conrads/Skimlite and their attorneys, Plaintiff immediately requested any and  
5 all evidence that the Conrads/Skimlite had to support/corroborate their assertion  
6 (that the “A.G. Pro Pole” was prior art). As noted above, if there was and is no  
7 proof that the A.G. Pro Pole qualifies as prior art, there is no reason for Plaintiff,  
8 the Patent Office, the courts, or anyone else to waste time, money, and other  
9 resources considering this “A.G. Pro Pole” in connection with Plaintiff’s ‘852  
10 Patent claims). Below is an excerpt of Plaintiff’s attorney’s October 20, 2021  
11 letter to Defendants’ attorneys in that regard, underscoring Plaintiff’s concern that  
12 the “A.G. Pro Pole” may simply be fake/fraudulent prior art created by and/or on  
13 behalf of Defendants:

Further in that regard, please know that my clients share your clients' opinion: the '852 inventions are likewise viewed by my clients as being **very important and very valuable**. As a consequence, my clients expect to review carefully each and every piece of evidence and argument that your clients may present. For example, depending on how things proceed, my clients are prepared to hire experts to review any and all of your clients' "evidence" that seems suspect. By way of further example, and as further discussed below, this includes carefully reviewing the "A.G. Pro Poles" alleged evidence that you presented for the first time in your Monday letter. We make our requests below for further information regarding that alleged "evidence" because we are aware that some infringers are tempted to create fraudulent evidence and even try to mislead a court with such fake information (see, for example,

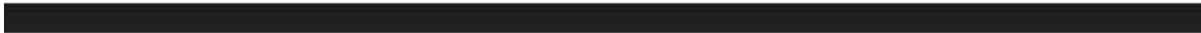

Messrs. Sganga and Stowell  
October 20, 2021  
Page 2

*FURminator, Inc. v. Kim Laube & Co., Inc.*, 758 F. Supp. 2d 797 (ED MO 2010); in addition, we have experienced opposing counsel and parties submitting what we believe is false evidence of this type in other lawsuits). Given the substantial value and importance of the '852 patent inventions, we intend to take all reasonable measures to be sure that is not happening in this case.

To underscore our concern about any such fraudulent/fake evidence, here is an excerpt from the *FURminator* decision cited above:

"In the December 21, 2009 Order [doc. # 313], this Court found that Mr. Laube himself (not his attorneys) had acted in bad faith and committed a fraud on the Court. Specifically, the Court found that Mr. Laube had fabricated a fake pet grooming tool and falsely identified it as the "commercial embodiment" of U.S. Patent No. 5,339,840 ("the Koppel patent"), and as "prior art" to the '540 Patent. The Court also found that Mr. Laube then engaged in a series of actions designed to deceive Plaintiff and this Court into believing that the fake pet grooming tool was actually in existence before the effective day of the '540 Patent. Moreover, Mr. Laube's fabrication of a fake pet grooming tool was merely the latest in a pattern and practice of misrepresentations and misconduct in this case. As noted previously by this Court, there is evidence that Mr. Laube fabricated or modified at least one other pet grooming tool, and that he gave conflicting testimony in another court regarding whether he had design documents to support his assertion that he had been designing tools similar to the *FURminator* DeShedding Tools since 1975. Upon considering the misconduct of Mr. Laube in this case and the possible sanctions it could issue, the Court determined that it was appropriate to strike Mr. Laube's testimony and related evidence. While Defendant clearly disagrees with this conclusion, the Court believes that the sanction was appropriate, considering the seriousness of the fraudulent actions."

Second, although your letter asserts that the '852 patent Claims 1 and 20 (and all the other claims) are invalid, it appears that your clients have not made any allegation that their products do not infringe. That position is consistent with our current understanding: the Skimplite Snaplite poles clearly infringe. If your clients instead believe that their products do not infringe (because they lack some literal/equivalent element of Claims 1 and/or 20, for example), please advise.

1 179. In response to Plaintiff's request for corroborating evidence, the  
2 Conrads, Skimlite, and their attorneys **continued** to behave in a way that, frankly,  
3 seems at least somewhat strange, curious, paranoid, and/or even suspicious.  
4 Specifically, on November 5, 2021, more than two weeks after Defendants'  
5 attorneys sent the above October 18 letter, Conrads/Skimlite's attorneys finally  
6 permitted Plaintiff's attorney to inspect just the pole itself.<sup>40</sup> Although the  
7 attorneys represented that they were showing to Plaintiff's attorney the exact pole  
8 shown in the photos from their October 18, 2021 letter above, those attorneys still  
9 did **not** provide any corroborating evidence of the pole's provenance or its status as  
10 allegedly qualifying as prior art with respect to Plaintiff's inventions.

11 180. Accordingly, during that November 5, 2021 inspection, Plaintiff's  
12 attorney pointedly asked **again** for any and all such corroborating evidence.  
13 Conrads/Skimlite's attorneys responded that they expected to get back to Plaintiff  
14 in that regard "in a few days." In hindsight, and as further explained below, it  
15 seems at least possible that Conrads/Skimlite's attorneys did not have any such  
16 corroborating evidence at the time of that November 5 inspection (nor at the time  
17 when those Conrads/Skimlite attorneys sent their earlier October 18, 2021 letter  
18 asserting that the A.G. Pro Pole **was** prior art) – **because the Leduc declaration**  
19 **was not signed until five days later** (on November 10, 2021).

20 181. In any case, five days after that first inspection (on November 5,  
21 2021), and nearly a month after those attorneys had sent Plaintiff their October 18  
22 letter (asserting that the A.G. Pro Pole was prior art), Conrads/Skimlite's attorneys  
23

---

24 <sup>40</sup> Because Applicant's principals, Eric and Jenel Resh, live and work several  
25 hours away from the infringers' attorneys' offices (where the inspection was  
26 offered), Applicant's undersigned attorney went to the inspection in person and (by  
27 agreement with the infringers' attorneys) connected Eric and Jenel Resh via  
28 teleconference to the location of the inspection. This arrangement was also  
followed in the further November 12, 2021 inspection discussed below, to save the  
Reshes from significant time and expense and effort to drive to/from the  
inspection.

1 apparently finally obtained a declaration which purported to establish “facts”  
2 regarding the prior art status of the A.G. Pro Pole. As further discussed herein, that  
3 declaration apparently was signed by a person named Ray Leduc (a person  
4 unknown to Plaintiff), who apparently has lived north of Los Angeles since the  
5 1980’s.<sup>41</sup>

6 182. The strange/paranoid behavior of infringers Conrads/Skimlite and/or  
7 their attorneys continued. Although Conrads/Skimlite’s attorneys eventually  
8 permitted Plaintiff to “inspect” that Leduc declaration (a few days after Mr. Leduc  
9 apparently signed it), for some reason, those attorneys did **not** permit Plaintiff to  
10 copy or photograph or have a copy of that declaration. That refusal by Defendants’  
11 attorneys (to permit Plaintiff a copy of the Leduc declaration) is strange – the  
12 declaration will almost certainly be discoverable in any litigation between the  
13 parties over these issues, and “normally” such a declaration would be provided to  
14 the patent owner by an infringer asserting that the declaration established  
15 something as “prior art.” If the infringer does **not** provide that evidence, the  
16 infringer is effectively escalating the dispute directly into litigation, and forcing the  
17 patent owner to file a lawsuit to obtain that alleged “prior art”  
18 evidence/information.

19 183. As mentioned above, Defendants’ strange behavior seems to indicate  
20 that Defendants (and/or their attorneys) apparently do not even themselves believe  
21 the allegations set forth in the Leduc declaration, or at least that Defendants’  
22  
23

---

24 <sup>41</sup> Mr. Leduc’s declaration says that he lived in West Hills, California, for at  
25 least some of that time. On a related “geographical” point, and as further discussed  
26 below, the three SCP store locations mentioned by Mr. Leduc in his declaration (at  
27 which Mr. Leduc allegedly sold “A.G. Pro Poles”) are all located just north of Los  
28 Angeles. Two of those stores (as well as Mr. Leduc’s West Hills business) are  
located in the San Fernando Valley. In an “update” on Mr. Leduc’s allegations  
regarding those stores in 2000-2002, apparently two of the three stores have since  
been re-branded as “Superior Pool Products” stores.

1 attorneys do not want to be liable or tainted with presenting “false” evidence  
2 regarding an “A.G. Pro Pole.”

3 184. In any case, Plaintiff makes the comments herein about Defendants’  
4 Leduc declaration based on (1) Plaintiff’s attorney eventually viewing (but not  
5 being permitted to copy) that Leduc declaration, and (2) Plaintiff’s attorney seeing  
6 a date (of November 10, 2021) next to the signature on that Leduc declaration.

7 185. More specifically, on November 12, 2021 (two days after Mr. Leduc  
8 apparently signed his declaration), Defendants’ attorneys permitted Plaintiff to  
9 “inspect” that Leduc declaration (along with several other boxes and alleged pole  
10 components, and again inspecting the same “A.G. Pro Pole” from the first  
11 inspection on November 5). During this second “inspection,” Defendants’  
12 attorneys did **not** permit Plaintiff to copy or photograph the Leduc declaration, nor  
13 those few other boxes and materials. For clarity, the only pole presented as part of  
14 this second inspection was (according to Defendants’ attorneys) the same solitary  
15 pole from the November 5, 2021 inspection.

16 186. During that second November 12 inspection, Plaintiff asked whether  
17 those attorneys had any other information regarding the **specific** A.G. Pro Pole in  
18 their possession (in the inspections): where it had been found, who had been in  
19 possession of that pole, when and how it was located, etc. In response, those  
20 attorneys said that they **had** additional information, but that they were not  
21 “prepared to share that additional information” with Plaintiff.

22 187. Again, for the reasons mentioned above, this refusal by Defendants’  
23 attorneys seems very strange, especially for a well-established patent law firm and  
24 seasoned patent litigators. In any case, Plaintiff also expects to obtain that further  
25 information in any litigation that may become necessary with the  
26 Conrads/Skimlite, but to date the Conrads/Skimlite have refused to provide any  
27 such alleged “additional information” to Plaintiff.

1 188. As mentioned above, the Conrads/Skimlite attorneys did not provide  
2 to Plaintiff a copy of the above-described Declaration of Ray Leduc (and likewise  
3 did not permit Plaintiff to take photos of that declaration). However, based on  
4 some of the notes that those attorneys permitted Plaintiff's attorney to take during  
5 the November 12, 2021 inspection, the following appear to be allegations within  
6 that Leduc declaration (again, Plaintiff does not even know whether Mr. Leduc is a  
7 real person, and Plaintiff certainly is not currently in a position to attest to whether  
8 any of these "Leduc allegations" are true). Based on Plaintiff's attorneys' notes,  
9 Mr. Leduc alleges in his November 10, 2021 declaration as follows:

- 10 • Mr. Leduc has been a pool man (cleaning swimming pools for other people)  
11 since the early 1980's, with the exception of the years 1986-1990);
- 12 • In 2000, Mr. Leduc began working on what he called the A.G. Pro Pole, and  
13 he made the "A.G. Pro Pole" shown in the photos in the Conrads/Skimlite  
14 attorneys' October 18, 2021 letter;
- 15 • To make the "A.G. Pro Pole," an unnamed "neighbor" suggested to Mr.  
16 Leduc that Mr. Leduc should "reverse" a painter's pole;
- 17 • Mr. Leduc used the A.G. Pro Pole for 3-4 months in 2000, and continued to  
18 use it in his pool cleaning business for several years after that;
- 19 • Mr. Leduc approached the makers of the painter's pole he reversed (a  
20 company called Mr. Long-Arm) to see if they would be interested in making  
21 the A.G. Pro Pole. They told Mr. Leduc that they were not interested, due to  
22 the costs involved;
- 23 • Mr. Long-Arm did sell more painter's poles to Mr. Leduc, and at least one of  
24 Mr. Leduc's neighbors (also unnamed) came over to Mr. Leduc's house and  
25 saw those poles;
- 26 • In late 2000, Mr. Leduc began selling his A.G. Pro Poles to others in the  
27 pool industry. The purchasers were "primarily" a company/distributor  
28 called SCP. Mr. Leduc estimates that he sold at least 250 poles to SCP, in  
their stores in Canoga Park, Van Nuys, and Monrovia, California. Mr.  
Leduc consulted with Danny Cerventes (who worked at SCP), and priced the



1 poles at approximately \$50/pole. For convenient reference, Plaintiff expects  
 2 to supplement this filing with a map of those stores, along with indication of  
 3 the close proximity of Mr. Leduc and Defendants Conrads/Skimlite during  
 4 apparently at least a number of years in the 1980s and/or 1990s (indicating at  
 5 least the possibility that Mr. Leduc is a friend or acquaintance of the  
 6 Conrads/Skimlite, as discussed in *The Barbed Wire Case* and other decisions  
 7 above);

- 8 • Mr. Leduc also “gave” A.G. Pro Poles to third parties, namely two  
 9 individuals named Art Grimsmith and Roger Boez;
- 10 • The pole being shown and inspected at Defendants Conrads/Skimlite  
 11 attorneys’ offices is one that Mr. Leduc made and sold;
- 12 • Mr. Leduc attached to his declaration and discussed in his declaration  
 13 several purchase orders from Mr. Long-Arm, for “Super Tab Lok 8-16”  
 14 poles. These purchase orders were dated September 2000, February 2001,  
 15 and October 12 and 30, 2001. They appear to total 240 poles, but the last  
 16 document appears to credit ½ of the previous order (perhaps 12 units?)  
 17 because those poles apparently were cracked and not saleable. Mr. Leduc  
 18 says that he converted all or substantially all of those Mr. Long-Arm poles  
 19 into A.G. Pro Poles, and then sold or gave those away; and
- 20 • Mr. Leduc also attached an October 29, 2001 purchase order from Pentair  
 21 Pool Products for 75 aluminum adapters [as discussed elsewhere herein;  
 22 these aluminum adapters are generic parts used on the end of existing all-  
 23 fiberglass twist-lock pool poles].

24 189. As mentioned above, the Conrads/Skimlite infringers’ evidence does  
 25 **not** include any corroboration of Mr. Leduc’s “oral testimony” assertions in his  
 26 November 10, 2021 declaration. It also is not credible for a number of other  
 27 reasons, some of which are discussed below.

28 **a. Defendants’ “Evidence” Merely Lists/Consists of Unassembled  
 Commercially Available Poles/Parts**

190. As noted above, Mr. Leduc’s “mysterious” declaration included some  
 attached documents, and included some alleged “oral testimony” statements from

1 Mr. Leduc's declaration related to those documents. Importantly, none of those  
2 documents themselves relate to any actual **reversed/assembled** "A.G. Pro Pole,"  
3 or any such assembled pole being publicly used, publicly known, offered for sale,  
4 or sold, at **any** time (let alone prior to Plaintiff's relevant pole inventions).  
5 Accordingly, infringers are again only presenting uncorroborated oral testimony,  
6 which is insufficient to establish the "A.G. Pro Pole" as prior art.

7 191. More specifically, the documents attached to Defendants' Leduc  
8 declaration are directed to three types of prior art poles/components. Those  
9 documents have **no** corroboration showing that (a) these components ever were  
10 actually "reversed" and/or otherwise assembled into an "A.G. Pro Pole," (b) by  
11 Mr. Leduc or anyone, (c) in the years 2000-2002 or at any time prior to the  
12 photograph in Defendants' attorneys' letter of October 18, 2021. As discussed  
13 herein, without some corroboration regarding the alleged assembly, public use,  
14 public sale, etc. of these components, at a time that makes those assemblies "prior  
15 art," **the mere existence of these components is meaningless:**

16 192. Plaintiff again lists here those three unassembled and commercially  
17 available components that are included in Mr. Leduc's "oral testimony" declaration  
18 and related materials:

- 19 1. Prior art Mr. Long-Arm "painters' poles;"
- 20 2. Prior art aluminum swages/adapters for use with all-fiberglass twist-lock  
21 pool poles; and
- 22 3. Apparently prior art black rubber bicycle handlebar grips, for bicycle  
23 handlebars and prior art pool poles (and presumably many other possible  
24 uses).

25 193. Before discussing below further detail about each of those  
26 unassembled prior art components, and to provide a helpful frame of reference for  
27 considering those prior, existing, commercially-available aluminum swage  
28

1 adapters (commonly used on all-fiberglass pool poles) and handlebar grips  
2 (commonly used on all-fiberglass and other pool poles), Plaintiff first discloses and  
3 discusses briefly here all-fiberglass swimming pool poles.

4 *i. Prior Art ALL-FIBERGLASS Swimming Pool Poles Use Aluminum*  
5 *Swage Adapters and Grips Like Those Mentioned in Mr. Leduc's Declaration*  
6 *and Related Materials*

7  
8 194. Based on Plaintiff's current recollection and understanding, the  
9 aluminum swage adapters and grips **components** mentioned in Mr. Leduc's  
10 declaration and related materials apparently were commonplace in swimming pool  
11 pole products in 2000-2002, and they remain so today. As shown below, many  
12 swimming pool poles (of all kinds) used (and still use) bicycle-handlebar-style  
13 grips, and all-fiberglass twist-lock swimming pool poles used (and still use) the  
14 aluminum swage adapters. Below are examples and discussion related to same.<sup>42</sup>

15 195. Prior art "all fiberglass swimming pool poles" are distinct in many  
16 ways from all of the commercial embodiments of Plaintiff's inventions: whether  
17 those commercial embodiments of Plaintiff's inventions are made by Plaintiff or  
18 instead by one of the four known infringers, those commercial embodiments of  
19 "Plaintiff's inventions" swimming pool poles have (to date) been made from all  
20 aluminum tubes. Those prior art "all fiberglass swimming pool poles" are likewise  
21 patentably distinct from Plaintiff's '852 Patent claims (as discussed elsewhere  
22 herein).

23  
24  
25 <sup>42</sup> Mr. Leduc effectively "swore" in his declaration that he assembled those  
26 two commonplace prior art components onto a commonplace prior art Mr. Long-  
27 Arm painters' pole, and called his assembly an "A.G. Pro Pole." As noted  
28 repeatedly herein, however, he did not provide any corroborating evidence in that regard.

1 196. Among other things, all-fiberglass swimming pool poles typically  
 2 include (a) rubber bicycle-handlebar-style hand grips (on the gripping end of the  
 3 pole) and (b) aluminum adapters (on the “tool” end), as shown here:43

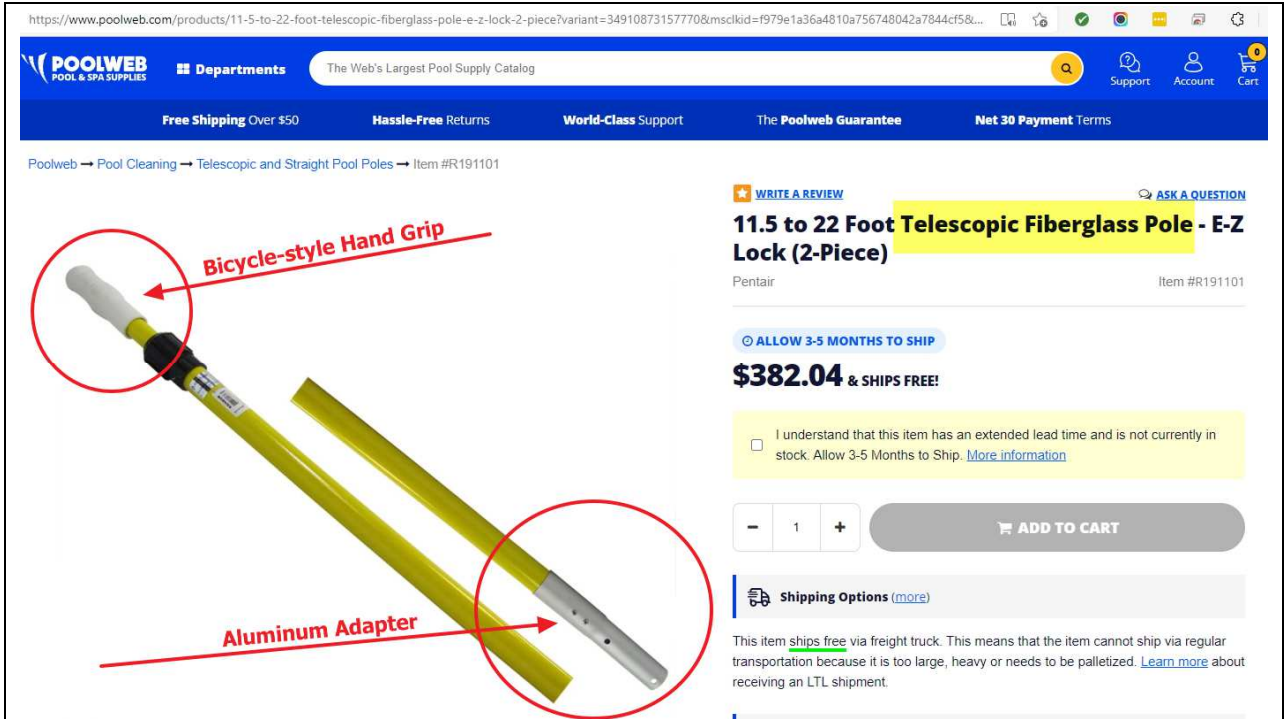

15 197. In passing, most of the thousands of poles shown on that same  
 16 website/search (whether all-fiberglass or all-aluminum) appear to have a rubber  
 17 bicycle-handlebar-style hand grip. Here is a screenshot of the top portion of those  
 18 search results, showing those handlebar-style grips:

22 43 Although this pole is sold and used as a “single” pole made from two  
 23 telescoping tubes, it is shown in this online screenshot in two parts because of its  
 24 length. This permits viewers to see details of both ends of the pole (from  
 25 [https://www.poolweb.com/products/11-5-to-22-foot-telescopic-fiberglass-pole-e-z-lock-2-piece?variant=34910873157770&msclkid=f979e1a36a4810a756748042a7844cf5&utm\\_source=bing&utm\\_medium=cpc&utm\\_campaign=\\*\\*LP%20-%20Shop%20-%20Hardware%20%26%20Accessories&utm\\_term=4582901905188568&utm\\_content=R191101%20%7C%2011.5%20to%2022%20Foot%20Telescopic%20Fiberglass%20Pole%20-%20E-Z%20Lock%20\(2-Piece\)%20%7C%20%24463.03](https://www.poolweb.com/products/11-5-to-22-foot-telescopic-fiberglass-pole-e-z-lock-2-piece?variant=34910873157770&msclkid=f979e1a36a4810a756748042a7844cf5&utm_source=bing&utm_medium=cpc&utm_campaign=**LP%20-%20Shop%20-%20Hardware%20%26%20Accessories&utm_term=4582901905188568&utm_content=R191101%20%7C%2011.5%20to%2022%20Foot%20Telescopic%20Fiberglass%20Pole%20-%20E-Z%20Lock%20(2-Piece)%20%7C%20%24463.03)).

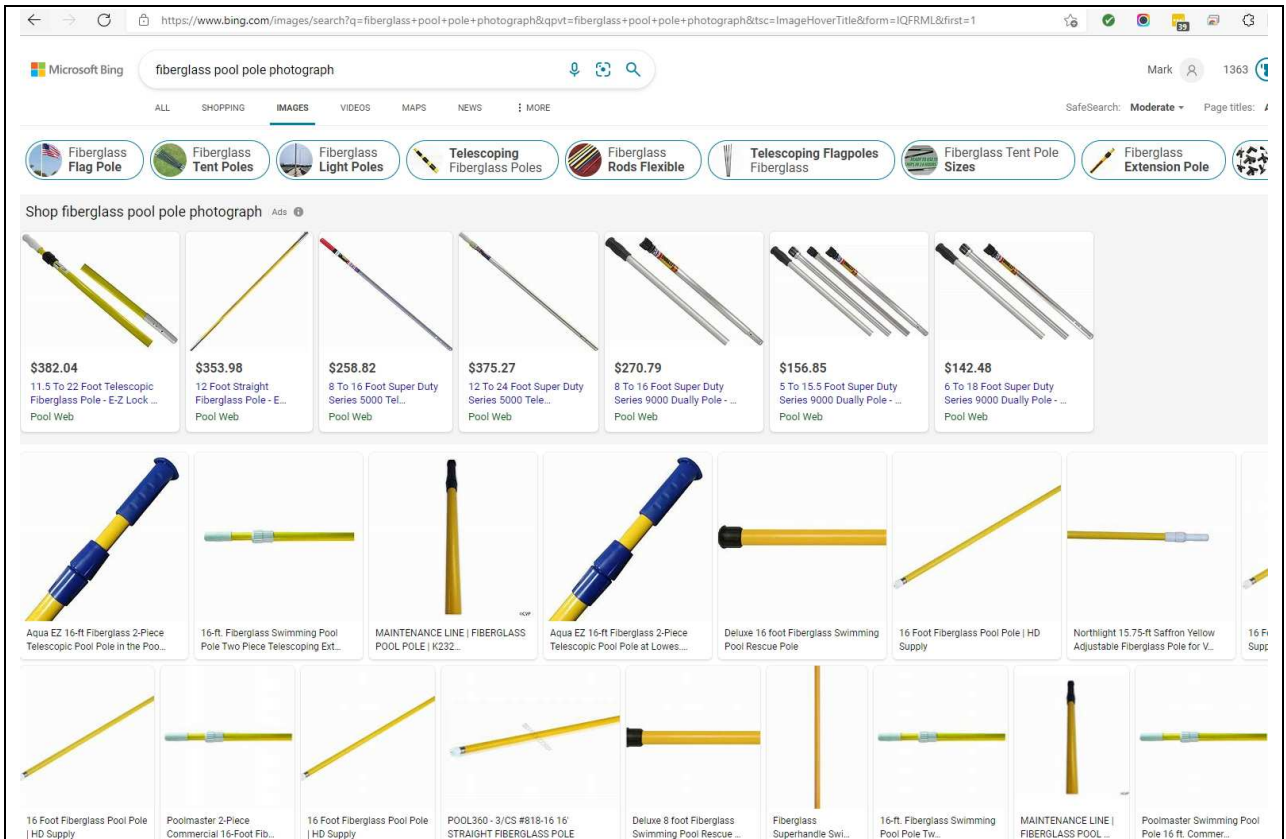

198. Other examples of “all fiberglass” swimming pool poles” include ones sold by Defendants Conrads/Skimlite. Below are screenshots regarding Skimlite’s current “8000 Series” all-fiberglass swimming pool poles (with a black bicycle-handlebar-style grip in the upper right part of the screenshot below):



199. Here are further details from that same online posting about Skimplite's all-fiberglass swimming pool poles:

- Non metal pole, not conducting electricity, hot or cold temperatures
- All lengths, depths, and sizes are approximate
- Fiberglass Tubing

Purchase Options



Skimplite 8000 Fiberglass Series Telepole with Outside Lock System | 12' to 24' | 2-Piece | 8024  
\$137.26

Skimplite created this line for customers needing fiberglass tubing. This American made pole provides all of the benefits of a nonmetal pole, such as not conducting electricity or hot and cold temperatures.

- Outside Lock has been an industry favorite since 1959 and is made of the strongest plastics ever made. the nylon male fitting is pressed onto the outside tube with a ton of pressure, so it won't fall off. The female and ferrule fittings are easily replaced when worn.

Brand: SKIMLITE

FROM: [https://www.poolsupplyunlimited.com/pool/skimplite-8016-fiberglass-series-outside-lock-telepole/91486p1?utm\\_source=google&utm\\_medium=organic&utm\\_campaign=surfaces&utm\\_term=%7Bquery%7D&gclid=Cj0KCQiA-](https://www.poolsupplyunlimited.com/pool/skimplite-8016-fiberglass-series-outside-lock-telepole/91486p1?utm_source=google&utm_medium=organic&utm_campaign=surfaces&utm_term=%7Bquery%7D&gclid=Cj0KCQiA-)

1 [eeMBhCpARIsAAZfxZAp24uAyfXSh2KrijDX-9VHrP-](#)  
2 [b4FoAtVIQO3cqcJBB2iNQC83w5jLIaAoBtEALw\\_wcB](#)

3 200. Like prior art all-aluminum poles, Skimlite’s and other all-fiberglass  
4 poles typically used twist-lock or clamp technology to adjust the length of the  
5 poles (similar to the black twist-lock nuts used on the Skimlite poles shown  
6 above).

7 201. Another relevant aspect of prior art all-fiberglass swimming pool  
8 poles is that they typically use an “aluminum swage/adapter.”<sup>44</sup> The prior art all-  
9 fiberglass swimming pool poles did not (and even today do not) attach tools  
10 directly to the fiberglass tubes. Instead, those poles typically included relatively  
11 short (approximately 7.5”) separate aluminum “swage” adapters attached to the  
12 “tool end” of one of the fiberglass tubes.

13 202. Below are screenshots showing current models of various twist-lock  
14 all fiberglass poles. According to the information presently available to Plaintiff,  
15 any such telescoping fiberglass pool poles that qualify as prior art with respect to  
16 Plaintiff’s inventions had a twist-lock or clamping mechanism to adjust the length  
17 of the pole. None of those telescoping fiberglass poles had detent/lever  
18 locks/buttons to adjust the pole length. Most or perhaps all of them included both  
19 a rubber bicycle-handle-style grip and an aluminum swage adapter.

20 203. The first example below has highlighting added by Plaintiff, to point  
21 out the twist-lock and the separate aluminum swage connector. The grip is at the  
22 end opposite the swage adapter. Both of these examples below show two  
23 FIBERGLASS tubes (yellow in the screenshots below) used to make a pool pole,  
24 and both use a separate aluminum swage connector for connecting tools:

25 \_\_\_\_\_  
26 <sup>44</sup> These prior art adapters appear to be similar or perhaps even identical to  
27 the aluminum swages/adapters used in both the alleged “hybrid”  
28 aluminum/fiberglass swimming pool poles discussed below (the Solakian  
prototype pole and the infringers’ alleged “A.G. Pro Pole”).

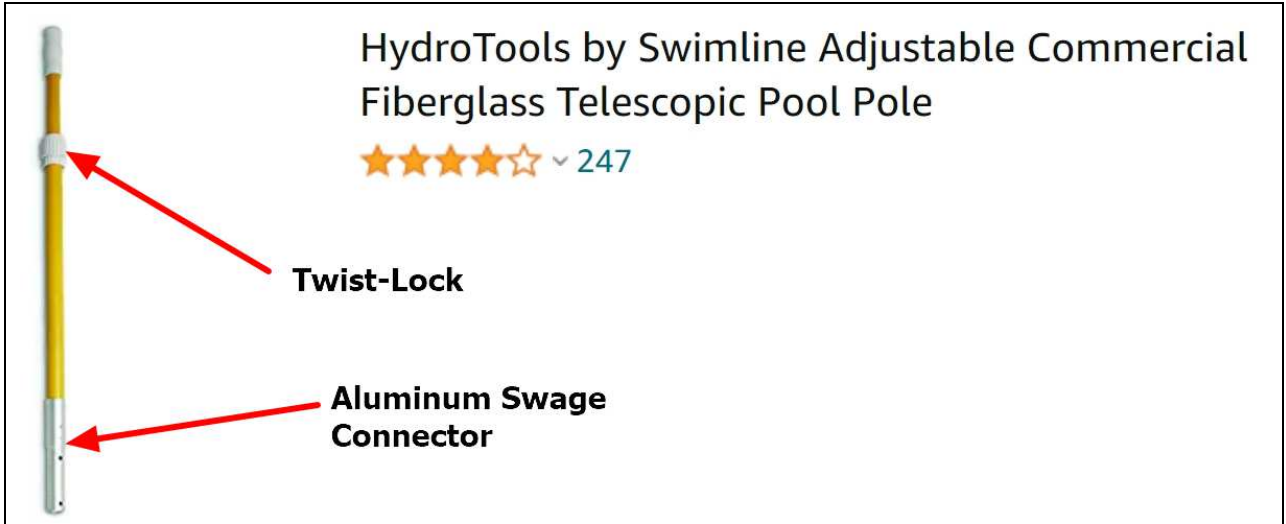

FROM:

[https://www.amazon.com/s?k=fiberglass+pool+pole&gclid=Cj0KCQiAkNiMBhCxARIsAIDDKNWaOJ\\_p4QtUqtn2crngUp07c\\_0R8zZpBoYsyQRdhuBF0Ws\\_TOCAGeUaAhxVEALw\\_wcB&hvadid=241588181664&hvdev=c&hvlocphy=9031549&hvnetw=g&hvqmt=e&hvrnd=4744716846927560009&hvtargid=kwd-4934486865&hydacr=13737\\_10192253&tag=googhydr-20&ref=pd\\_sl\\_4frkcueai4\\_e](https://www.amazon.com/s?k=fiberglass+pool+pole&gclid=Cj0KCQiAkNiMBhCxARIsAIDDKNWaOJ_p4QtUqtn2crngUp07c_0R8zZpBoYsyQRdhuBF0Ws_TOCAGeUaAhxVEALw_wcB&hvadid=241588181664&hvdev=c&hvlocphy=9031549&hvnetw=g&hvqmt=e&hvrnd=4744716846927560009&hvtargid=kwd-4934486865&hydacr=13737_10192253&tag=googhydr-20&ref=pd_sl_4frkcueai4_e)



FROM:

[https://www.poolsupplyunlimited.com/pool/skimlite-8016-fiberglass-series-outside-lock-telepole/91486p1?utm\\_source=google&utm\\_medium=organic&utm\\_campaign=surfaces&utm\\_term=%7Bquery%7D&gclid=Cj0KCQiAkNiMBhCxARIsAIDDKNX](https://www.poolsupplyunlimited.com/pool/skimlite-8016-fiberglass-series-outside-lock-telepole/91486p1?utm_source=google&utm_medium=organic&utm_campaign=surfaces&utm_term=%7Bquery%7D&gclid=Cj0KCQiAkNiMBhCxARIsAIDDKNX)



1 [SKtN15oLVQZeCNcpXB90vz0FQrwTMH86i3u1HXU1uad0UQvKxAsIaAug4E](https://www.poolsupplyunlimited.com/pool/skimlite-8016-fiberglass-series-outside-lock-telepole/91486p1?utm_source=google&utm_medium=organic&utm_campaign=surfaces&utm_term=%7Bquery%7D&gclid=Cj0KCQiAkNiMBhCxARIsAIDDKNXSKtN15oLVQZeCNcpXB90vz0FQrwTMH86i3u1HXU1uad0UQvKxAsIaAug4EALw_wcB)  
 2 [ALw\\_wcB](https://www.poolsupplyunlimited.com/pool/skimlite-8016-fiberglass-series-outside-lock-telepole/91486p1?utm_source=google&utm_medium=organic&utm_campaign=surfaces&utm_term=%7Bquery%7D&gclid=Cj0KCQiAkNiMBhCxARIsAIDDKNXSKtN15oLVQZeCNcpXB90vz0FQrwTMH86i3u1HXU1uad0UQvKxAsIaAug4EALw_wcB).

3 204. Below are related customer comments from that second Internet page  
 4 (immediately above), explaining some customers’ reasons for buying that  
 5 telescoping all-fiberglass swimming pool pole instead of an aluminum pole:

The screenshot shows the website header for POOL SUPPLY UNLIMITED with navigation links for POOL, SPA, RECREATION, PARTS, and BRANDS. A search bar is present. Below the header, there are navigation tabs: RELATED ITEMS, OVERVIEW, Q & A, REVIEWS, and FOR YOU. The main content area is titled 'OVERVIEW' and contains the following text:

Skimlite created this line for customers needing fiberglass tubing. This American made pole provides all of the benefits of a nonmetal pole, such as not conducting electricity or hot and cold temperatures.

- **Outside Lock** has been an industry favorite since 1959 and is made of the strongest plastics ever made. The nylon male fitting is pressed onto the outside tube with a ton of pressure, so it won't fall off. The female and ferrule fittings are easily replaced when worn.

Brand: SKIMLITE

**Why I Chose This:**

<p>“ The hubs wanted a stronger pole to clean the pool. No aluminum. Thought I'd give you a try, although your shipping cost is ridiculously high.                  —Lynda M., purchased May 16, 2021</p>	<p>“ Needed a pole for brushing that will not bend or break like the lightweight aluminum poles.                  —David C., purchased Aug 3, 2017</p>
<p>“ Because the 12-24 had an insane amount of shipping on it.                  —Adam L., purchased May 23, 2016</p>	<p>“ Wanted to try a professional grade fiberglass pole.                  —Paul C., purchased Dec 14, 2015</p>

20 FROM: [https://www.poolsupplyunlimited.com/pool/skimlite-8016-](https://www.poolsupplyunlimited.com/pool/skimlite-8016-fiberglass-series-outside-lock-telepole/91486p1?utm_source=google&utm_medium=organic&utm_campaign=surfaces&utm_term=%7Bquery%7D&gclid=Cj0KCQiAkNiMBhCxARIsAIDDKNXSKtN15oLVQZeCNcpXB90vz0FQrwTMH86i3u1HXU1uad0UQvKxAsIaAug4EALw_wcB)  
 21 [fiberglass-series-outside-lock-](https://www.poolsupplyunlimited.com/pool/skimlite-8016-fiberglass-series-outside-lock-telepole/91486p1?utm_source=google&utm_medium=organic&utm_campaign=surfaces&utm_term=%7Bquery%7D&gclid=Cj0KCQiAkNiMBhCxARIsAIDDKNXSKtN15oLVQZeCNcpXB90vz0FQrwTMH86i3u1HXU1uad0UQvKxAsIaAug4EALw_wcB)  
 22 [telepole/91486p1?utm\\_source=google&utm\\_medium=organic&utm\\_campaign=su](https://www.poolsupplyunlimited.com/pool/skimlite-8016-fiberglass-series-outside-lock-telepole/91486p1?utm_source=google&utm_medium=organic&utm_campaign=surfaces&utm_term=%7Bquery%7D&gclid=Cj0KCQiAkNiMBhCxARIsAIDDKNXSKtN15oLVQZeCNcpXB90vz0FQrwTMH86i3u1HXU1uad0UQvKxAsIaAug4EALw_wcB)  
 23 [rfaces&utm\\_term=%7Bquery%7D&gclid=Cj0KCQiAkNiMBhCxARIsAIDDKNX](https://www.poolsupplyunlimited.com/pool/skimlite-8016-fiberglass-series-outside-lock-telepole/91486p1?utm_source=google&utm_medium=organic&utm_campaign=surfaces&utm_term=%7Bquery%7D&gclid=Cj0KCQiAkNiMBhCxARIsAIDDKNXSKtN15oLVQZeCNcpXB90vz0FQrwTMH86i3u1HXU1uad0UQvKxAsIaAug4EALw_wcB)  
 24 [SKtN15oLVQZeCNcpXB90vz0FQrwTMH86i3u1HXU1uad0UQvKxAsIaAug4E](https://www.poolsupplyunlimited.com/pool/skimlite-8016-fiberglass-series-outside-lock-telepole/91486p1?utm_source=google&utm_medium=organic&utm_campaign=surfaces&utm_term=%7Bquery%7D&gclid=Cj0KCQiAkNiMBhCxARIsAIDDKNXSKtN15oLVQZeCNcpXB90vz0FQrwTMH86i3u1HXU1uad0UQvKxAsIaAug4EALw_wcB)  
 25 [ALw\\_wcB](https://www.poolsupplyunlimited.com/pool/skimlite-8016-fiberglass-series-outside-lock-telepole/91486p1?utm_source=google&utm_medium=organic&utm_campaign=surfaces&utm_term=%7Bquery%7D&gclid=Cj0KCQiAkNiMBhCxARIsAIDDKNXSKtN15oLVQZeCNcpXB90vz0FQrwTMH86i3u1HXU1uad0UQvKxAsIaAug4EALw_wcB).

26 205. As stated above, the “all-fiberglass” poles apparently are promoted  
 27 (by infringer Skimlite and perhaps others) as not conducting electricity, and not  
 28

1 getting “hot” or “cold” the way that metal pool poles can, depending on the  
2 weather. According to the statements above, some consumers also believe that the  
3 all-fiberglass poles are stronger than aluminum poles (and will therefore be less  
4 likely to bend or break).

5 206. In case it is not otherwise clear, the aluminum swage adapters shown  
6 above were (and still are) used to provide a conventionally sized aluminum  
7 attachment end to “all-fiberglass” swimming pool poles. The outermost end is  
8 shaped and sized to resemble the end of a conventional all-aluminum pole, so that  
9 the same tools can be used on either style pool pole. More specifically, as with all-  
10 aluminum poles, users of “all-fiberglass” swimming pool poles typically need to  
11 selectively attach (and detach) leaf rakes and brushes and other cleaning tools to  
12 the poles, to be able to use those different tools to clean swimming pools and not  
13 have to have a separate pole for each tool. As presently understood, the aluminum  
14 swage attachment ends/adapters on the “all-fiberglass” poles permit that desired  
15 selective attachment (with tools that also can be used on all-aluminum pool poles),  
16 and also reduce the risks (a) of damaging the fiberglass or (b) of fiberglass shards  
17 injuring the user. Replacement aluminum adapters were and still are sold,  
18 apparently in case the original adapters became damaged or unusable.

19 207. In fact, to Plaintiff’s knowledge, no one (to this day) attaches pool  
20 tools directly to a fiberglass pole.<sup>45</sup> Instead, all-fiberglass swimming pool poles  
21

22 <sup>45</sup> Another swimming pool pole manufacturer, Primate Pool Tools, makes (or  
23 has made) a carbon fiber pole that has tool attachment holes directly in its carbon  
24 fiber outer tube, with no swage or aluminum adapter. This may be possible with  
25 carbon fiber tubes, because the tube walls made from carbon fiber can be thinner  
26 than the tube walls made from fiberglass (carbon fiber is stronger than fiberglass).  
27 The attachment holes on carbon fiber tubes may also stay cleaner than the  
28 attachment holes drilled directly in fiberglass tubes. The resulting shards (in and  
around attachment holes in fiberglass) would be almost certain to severely damage  
a user’s hands (particularly the user’s thumb and forefinger) when attaching and/or  
removing a swimming pool tool from the pole. In another difference from  
Applicant’s pole inventions, Primate uses compression locks, and apparently  
started selling its poles after Applicant’s detent poles were already on the market.

1 typically attach their swaged aluminum adapter ends to the fiberglass tubes in a  
 2 way that requires additional parts, complexity, and steps to manufacture and/or  
 3 replace. Typically, the aluminum swages are attached to the ends of the fiberglass  
 4 tubes with a rivet or screw, and/or by gluing. Certain embodiments of Plaintiff's  
 5 claimed pole inventions below eliminate those extra parts and that complexity, by  
 6 permitting the attachment holes to be drilled or otherwise formed directly in the  
 7 sidewall of the aluminum tube itself.

8 *ii. Defendants' "Corroboration Evidence" Only Shows Unassembled*  
 9 *Commercially Available Prior Art Mr. Long-Arm Painters' Poles*

10 208. These components in the Leduc declaration (Mr. Long-Arm painters'  
 11 poles) are painters' poles, sold by a third party for use in painting. The fact that  
 12 Mr. Leduc may or may not have purchased or possessed (or even sold or given  
 13 away) such existing, commercially-available painters' poles at any time is  
 14 meaningless for purposes of corroborating his allegations of "prior art" "A.G. Pro  
 15 Poles."

16 209. Among other things, Plaintiff already disclosed to the Patent Office  
 17 these prior art Mr. Long-Arm painters' poles (both in Plaintiff's '852 patent  
 18 application itself, and during the '852 prosecution). In fact, near the end of page 3  
 19 of their October 18, 2021 letter above (see excerpt copied and highlighted below),  
 20 Defendants' attorneys even **admitted** that Plaintiff disclosed this prior art Mr.  
 21 Long-Arm painters' pole to the Patent Office during prosecution of Plaintiff's '852  
 22 patent, stating:

23 While a patent assigned to Mr. Longarm (U.S. Pat. No. 5,220,707, referred to as "Longarm Patent") was  
 24 discussed in the '852 patent's specification and prosecution history, the A.G. Pro Pole has different

25  
 26 210. Those disclosures by Plaintiff to the Patent Office include at least the  
 27 following within Plaintiff's '852 patent itself (from col. 5):  
 28

1 Also, the locking devices of telepoles used in other  
 2 applications are unsuitable for swimming pool cleaning  
 3 applications. For instance, external locking devices, such as 35  
 4 those found on telepoles used for window washing, painting,  
 5 or marine applications, tend to make pool cleaning difficult  
 6 as they can easily catch on the edge of a pool or other objects  
 7 when the telepole is being used, among other things. For  
 8 example, the Mr. Long Arm Pole (shown in U.S. Pat. No. 40  
 9 5,220,707) has an external locking device with a button that  
 10 activates a detent mechanism to engage and release the inner  
 11 tube of the telepole, but is not suitable in swimming pool  
 12 applications for a number of reasons. Among other things, it  
 13 is configured the opposite of what is desirable/useful 45  
 14 for cleaning swimming pools (i.e., the lighter parts of the pole  
 15 extending away from the user). Further, the Mr. Long Arm  
 16 pole is sealed at both ends by a grip on the outer tube end  
 17 and a threaded adapter on the inner tube end, and therefore  
 18 is unable to accommodate the commonly-used V-clips of 50  
 19 most swimming pool cleaning tools. Moreover, its inner tube  
 20 is unsealed on the end opposite the threaded adapter (the end  
 21 that is inserted into the outer tube) and where a series of  
 22 holes that receive the detent mechanism of the locking  
 23 device are located along the inner pole's length. These 55  
 24 openings in the inner tube would allow water to enter the  
 25 pole when it is placed in a pool, etc. and make the telepole  
 26 awkward and cumbersome to maneuver and control during  
 27 use. Additionally, since the grip is mounted on the end of the  
 28 outer pole, the detent mechanism would almost always be 60  
 underwater during use, and adjusting the pole's length  
 would inconveniently require a user to withdraw some or all  
 of the pole from the pool.

211. Plaintiff also submitted to the Patent Office separate detailed  
 information about the Mr. Long-Arm Painters' Poles, by filing related materials in  
 Information Disclosure Statements (IDS), such as shown on page 3 of the  
 "References Cited" at the beginning of Plaintiff's '852 patent, copied here:

Product photos of Mr. LongArm Button Lock extension pole,  
 www.mrlongarm.com, Sep. 10, 2015.  
 Product photos of Mr. LongArm extension pole with compression  
 nut locking device, www.mrlongarm.com, Sep. 10, 2015.

212. The Patent Office obviously allowed and issued Plaintiff's '852 patent  
 over that existing prior art Mr. Long-Arm patent/pole technology. Thus, and

1 again, without some corroborating evidence, the mere existence of Mr. Long-Arm  
2 painters' poles (in the possession of Mr. Leduc or anyone else) does not constitute  
3 prior art with respect to Plaintiff's pole inventions.

4 ***iii. Defendants' "Corroboration Evidence" Only Shows Unassembled***  
5 ***Commercially Available Prior Art Aluminum Swages/Adapters***  
6

7 213. Similar considerations apply to the other unassembled components  
8 Mr. Leduc identifies in his declaration. As discussed above, prior art aluminum  
9 swages or adapters are conventional generic parts sold for use with all-fiberglass  
10 swimming pool poles, and perhaps for other uses. The fact that Mr. Leduc may or  
11 may not have purchased or possessed (or even sold or given away) such existing,  
12 commercially-available swages/adapters at any time is meaningless for purposes of  
13 corroborating his allegations of assembled "prior art" "A.G. Pro Poles." Mr.  
14 Leduc may have had those aluminum swages for his own use on all-fiberglass  
15 swimming pool poles, or to give/sell to third parties, or for some other unrelated  
16 reason/s.

17 214. Again, without some actual corroboration, the existence of such  
18 aluminum swages or adapters (in the possession of Mr. Leduc or anyone else) does  
19 not constitute prior art with respect to Plaintiff's pole inventions.

20 ***iv. Defendants' "Corroboration Evidence" Only Shows Unassembled***  
21 ***Commercially Available Prior Art Rubber Bicycle Handlebar Grips***  
22

23 215. As with the foregoing Mr. Long-Arm painters' poles and aluminum  
24 swages or adapters, the apparently prior art conventional black rubber bicycle  
25 handlebar grips Mr. Leduc mentions in his declaration do not establish the "A.G.  
26 Pro Pole" as "prior art." As shown above, these grips appear to be conventional  
27 generic parts sold for bicycles handlebars and swimming pool poles of many types,  
28 and presumably for many other possible uses. The fact that Mr. Leduc may or may

1 not have purchased or possessed (or even sold or given away) such existing,  
 2 commercially-available grips at any time is meaningless for purposes of  
 3 corroborating his allegations of assembled “prior art” “A.G. Pro Poles.”

4 216. In addition to the foregoing information regarding “grips” for  
 5 swimming pool telepoles, Plaintiff sets forth here further evidence of the  
 6 ubiquitous nature of such “grips.” The Solakian’s company Val-Pak (discussed in  
 7 the ‘852 patent prosecution and elsewhere herein) itself makes a “bicycle-style  
 8 handle grip” for telescoping swimming pool poles. As shown below, that part is  
 9 available on Amazon:



16 217. Moreover, Defendants Conrads/Skimlite have products (infringing  
 17 and others) that use these same types of “bicycle handlebar grips,” as shown in the  
 18 following online websites:

- On infringer Skimlite’s own website, they show that **Skimlite itself uses bicycle-style handgrips** on most, if not all, of its poles:

Please contact your local distributor for pricing and availability. If you are a homeowner looking for parts and cannot buy through distribution please [CLICK HERE](#) for some online options.



218. Other websites sell Skimlite poles, and shoppers even ask for generic replacement “bicycle grips”:

1  
2  
3  
4  
5  
6  
7  
8  
9  
10  
11  
12  
13  
14  
15  
16  
17  
18  
19  
20  
21  
22  
23  
24  
25  
26  
27  
28

https://www.bing.com/search?q=skimlite%20grips&q&form=QBRE&sp=-1&pq=skimlite%20grips&sc=1

skimlite grips

ALL SHOPPING IMAGES VIDEOS MAPS NEWS MORE

19,300 Results Any time

See skimlite grips

Ergon - GP1 Biokork... \$49.95 Amazon.com	Jumbomax JMX Ultralit... \$15.99 Amazon.com Free shipping	Chromag Squarewave... \$35.00 evo	Skimlite Hand Grip... \$9.88 Pool Supply...	Skimlite Pole Grip Black... \$9.88 Pool Supply...	Lamkin Golf Sonar+ Tour... \$9.49 Rock Bott... Ave

Skimlite Pole Grip | Black | 5552

https://www.poolsupplyunlimited.com/pool/skimlite-5552-pole-grip/168809p1

Home Pool Pool & Spa Maintenance Supplies Replacement Parts Skimlite Pole Grip | Black | 5552. NOTICE: The pool & spa industry continues to face industry ...

Brand: SKIMLITE Price: \$8.44

Images of Skimlite GRIPS

bing.com/images

Skimlite Pole Grip   Red   5553	Skimlite Pole Grip   Black   5552	Skimlite Hand Grip White   555	POOL360 HAND GF

See all images >



1  
2  
3  
4  
5  
6  
7  
8  
9  
10  
11  
12  
13  
14  
15  
16  
17  
18  
19  
20  
21  
22  
23  
24  
25  
26  
27  
28

https://www.poolsupplyunlimited.com/pool/skimlite-6012-snaplite-telepole-with-button-lock-pole/168473p1

**POOL SUPPLY UNLIMITED** POOL SPA RECREATION PARTS BRANDS Have a Question? (888) 836-6025 Account Cart

Search for items  Sign up for e-mails  SIGN UP

Home > Pool > Pool & Spa Maintenance Supplies > Poles > Skimlite 6000 Snaplite Series Telepole with Button Lock Pole | 6' to 12' | 2-Pieces | 6012

**CHAT WITH US**

**NOTICE:** The pool & spa industry continues to face industry-wide shortages on many products that most vendors expect to last late into early 2022. We're allowing items to be purchased so that customers who choose to wait will have their order shipped when product is available. WE WILL EMAIL YOU RIGHT AWAY IF YOUR ITEM IS BACKORDERED. Please contact us via [Live Chat](#) for the quickest response.

**Skimlite 6000 Snaplite Series Telepole with Button Lock Pole | 6' to 12' | 2-Pieces | 6012**

★★★★☆ Read 2 Reviews or Write a Review

**\$81.62**

Quantity:

**BUY NOW**

- With a simple push of a button snap your pole to the desired length
- Have a unique decagon shape to them which keeps the pole from rotating

Flat Rate Shipping \$35.00  
Gold Preferred Manufacturer

**Purchase Options**

- Skimlite 6000 Snaplite Series Button Lock Pole | 8' to 16' | 2-Pieces | 6016 \$96.05
- Skimlite 6000 Snaplite Series Button Lock Pole | 6' to 17' | 3-Pieces | 6317 \$125.49

**Need advice or looking for more information?**  
Type in your question & press Enter.  
or Browse 2 questions and 0 answers

OVERVIEW Q & A REVIEWS FOR YOU

**OVERVIEW**

Poles for the most demanding jobs designed for the professionals

**SNAPLITE™ SERIES** The SnapLite™ series is quickly becoming one of Skimlite's most popular poles. The lock is similar to what has been utilized as the primary locking mechanism in the painting industry for years. With a simple push of a button you can slide and lock your pole to your desired length. All SnapLite™ poles have a unique decagon shape to them which keeps the pole from rotating and provides ultra-smooth sliding.

**CHAT WITH US**

- Snaplite** Skimlite's newest lock design that allows you to slide and lock the pole at your desired length with a simple push of a button

Brand: SKIMLITE

**Q & A**

Powered by TurnTo

Have a question about this? Ask people who own it.

Start typing your question and we'll check if it was already asked and answered. [Learn More](#)

**Browse 2 questions**

**Where can I buy a replacement lock button for this pole?**  
Scott B on Jun 29, 2019  
[Add Answer](#) [I Have This Question Too \(5\)](#)

**What size bicycle grip will fit this pole?**  
A shopper on Aug 25, 2021  
[Add Answer](#) [I Have This Question Too \(0\)](#)

- Here are some of the many third-party pool poles (PoolWhale and Yeechun and AgiiMan) that use “bicycle handlebar style grips”:

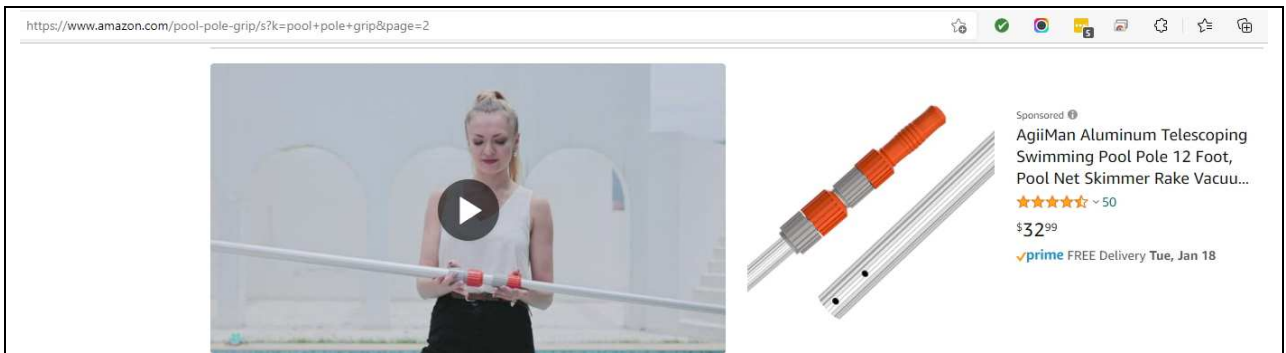

- Another of Defendants of Plaintiff’s recent ‘852 patent (AquaEZ) also uses “bicycle-style handle grips” on their poles of all types:

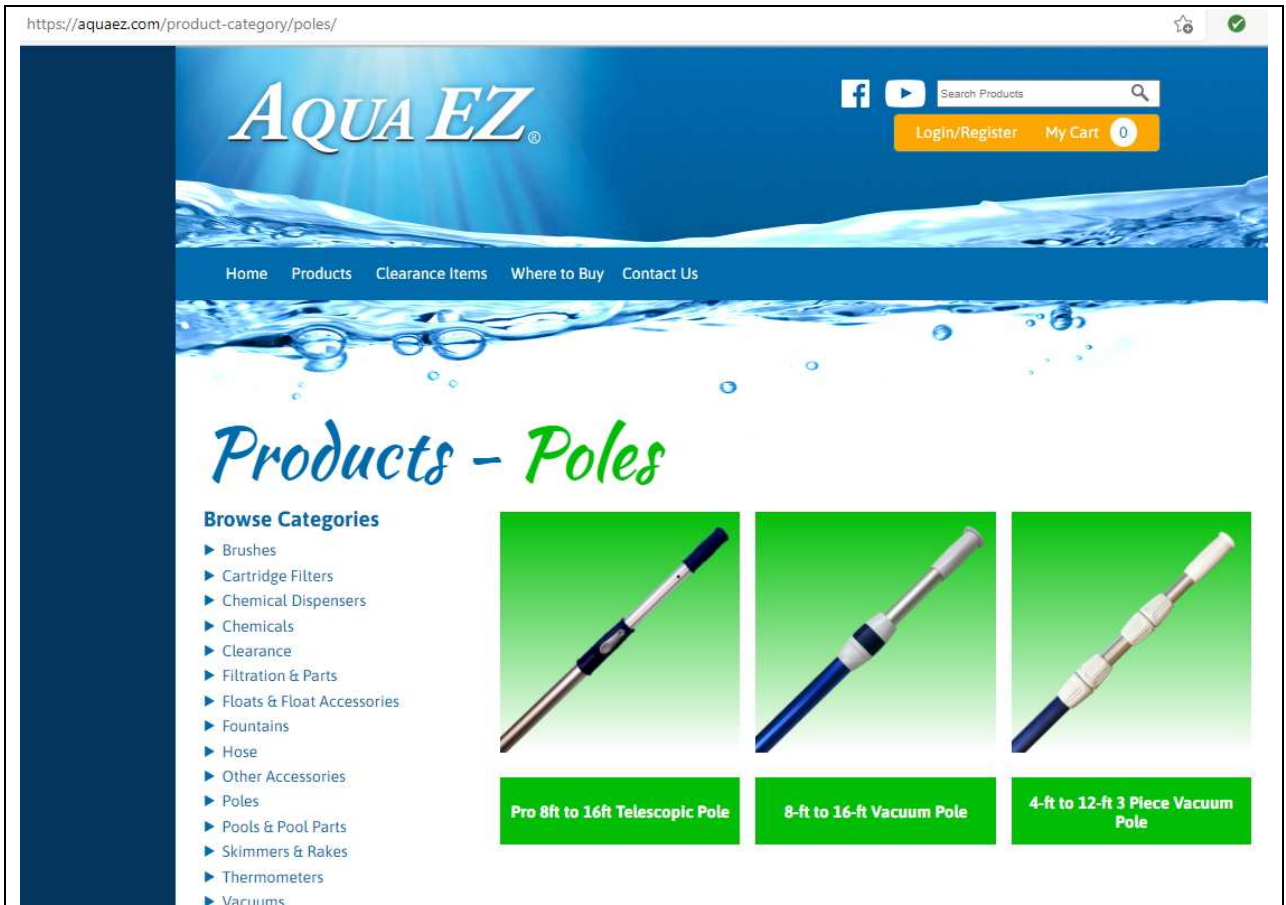

- 15 • AquaEZ offers an all-fiberglass pole that uses bicycle-style hand grips  
16 (from  
17 [https://www.bing.com/images/search?q=fiberglass+pool+pole+photograph&](https://www.bing.com/images/search?q=fiberglass+pool+pole+photograph&qpvt=fiberglass+pool+pole+photograph&tsc=ImageHoverTitle&form=IQFRML&first=1)  
18 [qpvt=fiberglass+pool+pole+photograph&tsc=ImageHoverTitle&form=IQFRML&first=1](https://www.bing.com/images/search?q=fiberglass+pool+pole+photograph&qpvt=fiberglass+pool+pole+photograph&tsc=ImageHoverTitle&form=IQFRML&first=1)):



- Perhaps most importantly for the current issues (including whether rubber hand grips and aluminum pole adapters by themselves constitute “prior art”), other **all-fiberglass** poles use both those commodities (handlebar grips and aluminum adapters), as shown in this Pentair pole online page:

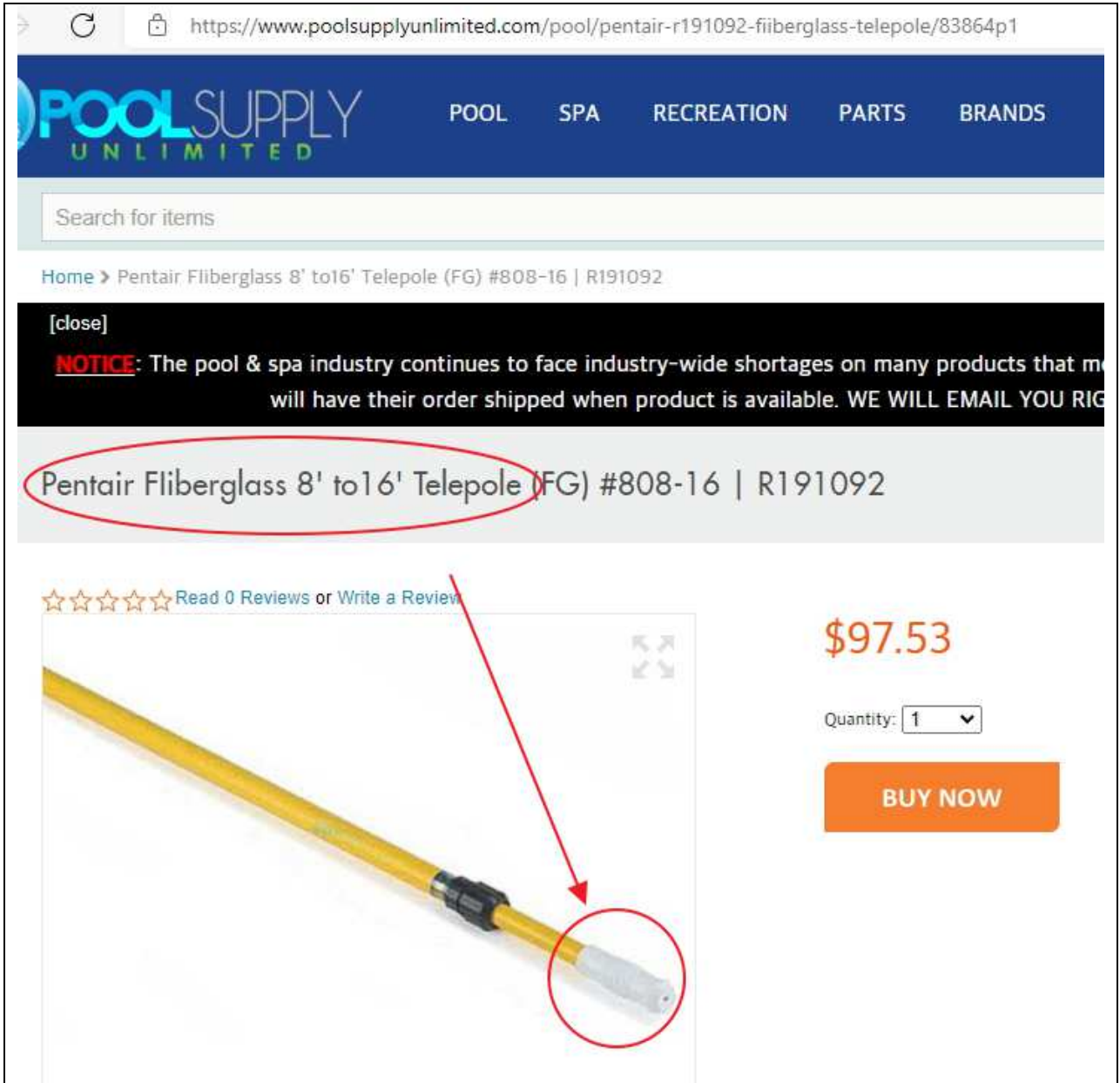

1           **b. Defendants’ “Corroboration Evidence” is Conspicuously Missing**  
 2           **Any Actual Dated, CORROBORATING Documents or Other Evidence**

3           219. As the Federal Circuit noted in 1999, in the *Finnigan* decision above  
 4           (citing *Woodland Trust v. Flowertree Nursery, Inc.*, 148 F.3d 1368, 1373, 47  
 5           USPQ2d 1363, 1367 (Fed.Cir.1998):

6                   “... the **skepticism** with which **mere testimony** of invalidating  
 7                   activity is received is ‘reinforced, in modern times, by the ubiquitous paper  
 8                   trail of virtually all commercial activity. **It is rare indeed that some**  
 9                   **physical record** (e.g., a written document such as notes, letters, invoices,  
 10                   notebooks, or a sketch or drawing or photograph showing the device, a  
 11                   model, or some other contemporaneous record) **does not exist.**”

12                   (Emphasis added).

13  
 14           220. By way of example in the present case, the Conrads/Skimlite  
 15           infringers have not produced any evidence that itself is dated, regarding an  
 16           **assembled** “A.G. Pro Pole.” They have not produced any contemporary evidence  
 17           from Mr. Leduc’s alleged 2000-2002 sales/use of the A.G. Pro Pole. Without  
 18           limitation, such evidence might include:

- 19  
 20                   • photographs  
 21                   • promotional materials (advertisements, hangtags, etc.)  
 22                   • related invoices  
 23                   • receipts  
 24                   • cancelled checks or credit card payments  
 25                   • bank statements  
 26                   • other financial records, etc.

27           221. In short, Defendants Conrads/Skimlite have not presented any  
 28           corroborating evidence regarding:

- 1 • the alleged sale (or even offering for sale) of A.G. Pro Poles, to SCP or  
2 anyone else, at any time (let alone prior to Plaintiff’s relevant pole  
3 inventions); and/or
- 4 • the alleged public use or public knowledge of any A.G. Pro Pole, at any time  
5 (let alone prior to Plaintiff’s relevant pole inventions).

6 222. Based on the case law discussed above, this complete absence of any  
7 dated documents or similar corroboration (showing the alleged, actual, assembled  
8 “A.G. Pro Pole” at the relevant time frame) is a fatal blow to the credibility of  
9 Defendants’ allegations. In other words, Defendants Conrads/Skimlite have not  
10 met their burden to establish that the “A.G. Pro Pole” is prior art with respect to  
11 Plaintiff’s inventions/applications/claims.

**PRAYER**

WHEREFORE, Plaintiff Resh prays for relief as follows:

- A. For a judgment declaring that the ‘852 Patent is not invalid;
- B. For a judgment declaring that Defendants’ SkimLite and similar poles (such as those Defendants private-label for third parties) infringe the ‘852 Patent, in view of Defendants’ actions of making, using, selling, offering for sale, and/or importing those poles;
- C. For a judgment declaring that Defendants’ infringement of Plaintiff’s ‘852 Patent has been willful and deliberate;
- D. For a grant of a permanent injunction pursuant to 35 U.S.C. §283, enjoining the Defendants from future acts of infringement;
- E. For an award of damages pursuant to 35 U.S.C. §284, in an amount sufficient to compensate Plaintiff for the foregoing infringement, but in no event less than a reasonable royalty for the use Defendants have made of Plaintiff’s ‘852 Patent inventions, together with interest and costs as fixed by the Court;
- F. For an award of pre-issuance damages pursuant to 35 U.S.C. §154; and
- G. For such other and further relief as the Court deems just and proper.

**DEMAND FOR JURY TRIAL**

Pursuant to Rule 38(b) of the Federal Rules of Civil Procedure, demand is hereby made for trial by jury on all issues properly triable by jury.

Respectfully submitted,

Dated: March 7, 2022

/s/J. Mark Holland  
J. Mark Holland  
**J. MARK HOLLAND & ASSOCIATES**  
Attorney for PLAINTIFF RESH

[https://d.docs.live.net/365d5d3a52bd96fc/Clients/RESH/L4084\\_Skimlite-Conrad\\_2021-06/Pleadings/Complaint-Related/Drafts/2022-03-07\\_Complaint\\_FINAL.docx](https://d.docs.live.net/365d5d3a52bd96fc/Clients/RESH/L4084_Skimlite-Conrad_2021-06/Pleadings/Complaint-Related/Drafts/2022-03-07_Complaint_FINAL.docx)

1  
2  
3  
4  
5  
6  
7  
8  
9  
10  
11  
12  
13  
14  
15  
16  
17  
18  
19  
20  
21  
22  
23  
24  
25  
26  
27  
28



**EXHIBIT A**

**Plaintiff's '852 Patent**



US011141852B2

(12) **United States Patent**  
**Resh**

(10) **Patent No.: US 11,141,852 B2**  
(45) **Date of Patent: Oct. 12, 2021**

(54) **TELEPOLE APPARATUS AND RELATED METHODS**

FOREIGN PATENT DOCUMENTS

(71) Applicant: **Eric V Resh**, Temecula, CA (US)

AU 640080 12/1993  
AU 2005200684 B2 8/2010

(Continued)

(72) Inventor: **Eric V Resh**, Temecula, CA (US)

(73) Assignee: **Resh, Inc.**, Murrieta, CA (US)

OTHER PUBLICATIONS

(\* ) Notice: Subject to any disclaimer, the term of this patent is extended or adjusted under 35 U.S.C. 154(b) by 181 days.

Declaration of Rich Gross, dated Dec. 21, 2016.  
Declaration of Mike Solakian, dated Jan. 15, 2016.  
Declaration of Dick Gross, dated Jan. 12, 2017.  
Declaration of Jenel Resh, dated Nov. 12, 2015.  
Second Declaration of Jenel Resh, dated Nov. 12, 2015.

(Continued)

(21) Appl. No.: **15/708,038**

(22) Filed: **Sep. 18, 2017**

*Primary Examiner* — Robert J. Scruggs  
(74) *Attorney, Agent, or Firm* J. Mark Holland & Associates; J. Mark Holland; Auson Adnan

(65) **Prior Publication Data**

US 2018/0009099 A1 Jan. 11, 2018

(57) **ABSTRACT**

**Related U.S. Application Data**

(63) Continuation-in-part of application No. 13/844,561, filed on Mar. 15, 2013, and a continuation of (Continued)

(51) **Int. Cl.**  
**B25G 1/04** (2006.01)  
**B25G 3/18** (2006.01)

(52) **U.S. Cl.**  
CPC ..... **B25G 1/04** (2013.01); **B25G 3/18** (2013.01)

(58) **Field of Classification Search**  
CPC ..... B25G 1/102; B25G 1/10; B25G 1/105; B25G 1/00; B25G 1/01; B25G 1/04; (Continued)

(56) **References Cited**

U.S. PATENT DOCUMENTS

2,546,157 A 3/1951 Ilume  
2,641,012 A 6/1953 Storrs  
(Continued)

An improved telepole device having attachment means for attaching swimming pool cleaning, and other tools. The improved telepole device preferably includes an inner tube which freely slides within an outer tube, and a locking device to temporarily secure the inner tube in a desired position within the outer tube. A preferred lightweight design may be at least partially hollow along the length of the tube(s), and durability may be provided by inner/reinforcement wall(s) that extend across the hollow portion(s) of one or both of the tubes. On the end of the outer tube through which the inner tube slides/extends is a collar element attached thereto and comprised of a locking device having a detent mechanism for "locking" the inner tube in place within the outer tube. Preferably, the collar's opening and the profile of the inner tube have one or more sides that, due to their relative position with respect to each other, can prevent the inner tube from rotating within the collar. Further, the inner tube preferably has a series of holes along its length which are positioned to receive a pin element of the detent mechanism. Further, the end of the outer tube opposite the collar preferably has attachment holes configured to receive attachable and detachable swimming pool cleaning tools, and an additional set of holes that allow water to drain from the outer tube while a tool is attached.

**24 Claims, 16 Drawing Sheets**

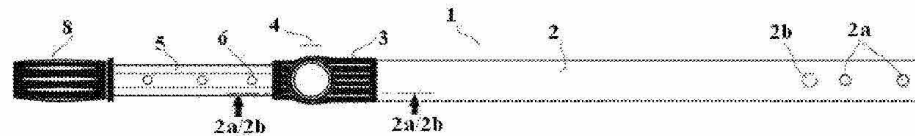

US 11,141,852 B2

Page 2

Related U.S. Application Data

application No. 13/624,702, filed on Sep. 21, 2012, now Pat. No. 9,764,458.

(60) Provisional application No. 61/538,074, filed on Sep. 22, 2011.

(58) **Field of Classification Search**  
 CPC .... B25G 3/18; B25G 3/20; F04H 3/16; E04H 4/00; F16D 1/10; F16B 7/10; A01K 75/00  
 See application file for complete search history.

(56) **References Cited**

U.S. PATENT DOCUMENTS

2,706,664	A	4/1955	Conrad	
3,243,830	A	4/1966	Conrad	
3,347,575	A	10/1967	Morris	
3,407,424	A *	10/1968	Lanzarone	..... A47L 13/24 15/145
3,419,293	A	12/1968	Conrad	
3,471,022	A	10/1969	Conrad	
3,596,946	A	8/1971	Burton	
3,603,623	A	9/1971	Widman	
4,247,216	A *	1/1981	Fansini	..... B25G 3/18 15/1.7
4,325,157	A *	4/1982	Balint	..... B05C 17/0205 15/144.4
4,369,109	A	1/1983	Edge	
4,400,028	A	8/1983	Conrad	
4,413,660	A	11/1983	Conrad	
4,479,599	A	10/1984	Conrad	
4,662,771	A	5/1987	Roe	
4,663,796	A	5/1987	Ielling	
4,822,487	A	4/1989	Soich	
5,173,181	A *	12/1992	McFarland	..... B01D 29/27 15/1.7
5,220,707	A	6/1993	Newman, Sr.	
5,288,161	A	2/1994	Graves	
5,293,662	A	3/1994	Newman	
5,316,264	A	5/1994	Newman	
5,316,624	A	5/1994	Newman, Sr.	
5,317,776	A *	6/1994	DeMoura	..... E04H 4/1636 15/1.7
D354,554	S	1/1995	Newman	
5,487,397	A	1/1996	Bean	
5,536,107	A	7/1996	Baker	
5,579,557	A	12/1996	Boden	
5,590,974	A	1/1997	Yang	
5,682,641	A	11/1997	Newman, Jr.	
5,692,856	A	12/1997	Newman, Jr.	
5,694,695	A	12/1997	Lund	
5,743,577	A	4/1998	Newman	
5,858,221	A	1/1999	Conrad	
5,966,783	A	10/1999	Conrad	
5,983,455	A *	11/1999	Polzin	..... B05C 17/0205 15/144.4
6,254,305	B1	7/2001	Taylor	
D452,777	S	1/2002	Newman	
6,349,451	B1	2/2002	Newman	
6,474,696	B1 *	11/2002	Canale	..... A47L 9/244 285.7
6,530,124	B2	3/2003	Newman	
6,532,630	B1	3/2003	Newman	
6,546,596	B2	4/2003	Grote	
6,854,916	B2	2/2005	Ilsieh	
D519,820	S	5/2006	Newman	
7,096,530	B2	8/2006	Goulet	
7,284,928	B2	10/2007	Perez	
7,392,909	B1	7/2008	Conrad	
7,673,365	B1 *	3/2010	Griffin, Sr.	..... E04F 21/244 15/144.1
7,716,790	B2	5/2010	Newman, Jr.	
7,721,391	B2	5/2010	Bukovitz	
D644,907	S	9/2011	Blanchard	
D661,905	S	6/2012	Best	

8,240,008	B2	8/2012	Newman, Jr.	
8,875,350	B2	11/2014	Bukovitz	
9,744,662	B1	8/2017	IHenry	
2005/0279520	A1	12/2005	Newman	
2008/0156715	A1	7/2008	Iletzner	
2010/0109357	A1 *	5/2010	Lofley, Sr.	..... B25G 1/04 294/210
2010/0192738	A1	8/2010	Fenstermaker	
2010/0269648	A1	10/2010	Fenstermaker	
2011/0247163	A1	10/2011	Chen	
2013/0266364	A1	10/2013	Soares	
2013/0322957	A1	12/2013	Conrad	
2018/0141202	A1	5/2018	Newman	
2019/0275659	A1	9/2019	Conrad	

FOREIGN PATENT DOCUMENTS

CA	2398081	8/2001
CA	2353287	2/2002
EP	1496536	12/2005
WO	1995002140	1/1995
WO	1998003313	1/1998

OTHER PUBLICATIONS

Ningbo Duanchuan Swimming Pool Equipment Co., Ltd., DuanChuan Product Catalog, pp. 1-3, 1, 9-10, 21-22, 31-33, [www.chinapoolproducts.com](http://www.chinapoolproducts.com), Sep. 20, 2015.

Ocean Blue Water Products, Ocean Blue Water Products Catalog, pp. 1, 8-15, <http://www.oceanbluewaterproducts.com/Pdf/catalog.pdf>, Sep. 9, 2015.

Oreq Corporation, Oreq 2015 Maintenance Equipment Catalog, pp. 1-4, 6, [www.oreqcorp.com](http://www.oreqcorp.com).

Catalog page for Super Lok Pro Contractor, Mr. LongArm, Inc., [www.mrlongarm.com](http://www.mrlongarm.com), Sep. 10, 2015.

Catalog page for Smart-Lok Pro Contractor, Mr. LongArm, Inc., [www.mrlongarm.com](http://www.mrlongarm.com), Sep. 10, 2015.

Screenshots from [dongchuan.en.chinaningbo.com](http://dongchuan.en.chinaningbo.com), Ningbo Duanchuan Swimming Pool Equipment Co., Ltd., Sep. 9, 2015.

Screenshot from [lionpool.com](http://lionpool.com), Lion Pool Products Brochure, <http://lionpool.com/webimage/pdf/lion-pool-products-brochure.pdf>, Aug. 13, 2015.

Screenshots from [www.doheny.com](http://www.doheny.com), Doheny's Water Wearhouse, Doheny Enterprises, Inc., Sep. 9, 2015, <http://www.doheny.com/poolsupplies/Aqua-Broom-Pool-Cleaner-4857.html>.

Screenshots from [www.doheny.com](http://www.doheny.com), Doheny's Water Wearhouse, Doheny Enterprises, Inc., Sep. 9, 2015, <http://www.doheny.com/poolsupplies/Muck-Vac-Pressure-Pool-Cleaner-427.html>.

Screenshots from [www.doheny.com](http://www.doheny.com), Doheny's Water Wearhouse, Doheny Enterprises, Inc., Sep. 9, 2015, <http://www.doheny.com/poolsupplies/Aluminum-Telescoping-Poles.html>.

Screenshots from [www.intheswim.com](http://www.intheswim.com), In the Swim, Sep. 9, 2015, <http://www.intheswim.com/p/telescoping-pole>.

Screenshots from [www.intheswim.com](http://www.intheswim.com), In the Swim, Sep. 9, 2015, <http://www.intheswim.com/p/superhandle-telescopic-pole>.

Screenshots from [www.intheswim.com](http://www.intheswim.com), In the Swim, Sep. 9, 2015, <http://www.intheswim.com/p/telescoping-pole-with-leaf-skimmer>.

Screenshot from [www.poolsuppliesuperstore.com](http://www.poolsuppliesuperstore.com), Pool Supplies Superstore, Sep. 9, 2015, <http://www.poolsuppliesuperstore.com/poolsupplies/Aluminum-Telescoping-Poles-2915.html>.

Screenshots from [www.poolsupplyworld.com](http://www.poolsupplyworld.com), PoolSupplyWorld, Sep. 9, 2015, <http://www.poolsupplyworld.com/Splash-NA302-5-15-Telescoping-Pole-3-Piece-NA302.html>.

Screenshots from [www.poolsupplyworld.com](http://www.poolsupplyworld.com), PoolSupplyWorld, Sep. 9, 2015, <http://www.poolsupplyworld.com/Splash-PL2515-Deluxe-3-Piece-Telescoping-Pole-PL2515.html>.

Screenshots from [www.poolcenter.com](http://www.poolcenter.com), POOLCENTER.com, Inc., Sep. 9, 2015, <http://www.poolcenter.com/p/telescopic-swimming-pool-poles>.

Screenshots from [www.poolcenter.com](http://www.poolcenter.com), POOLCENTER.com, Inc., Sep. 9, 2015, <http://www.poolcenter.com/p/superhandle-telescopic-swimming-pool-pole>.

Screenshots from [www.poolcenter.com](http://www.poolcenter.com), POOLCENTER.com, Inc., Nov. 11, 2015, <http://www.poolcenter.com/p/skimlite-professional-dual-lock-telepoles>.

EXHIBIT A to COMPLAINT

## US 11,141,852 B2

Page 3

(56)

## References Cited

## OTHER PUBLICATIONS

- Screenshots from [www.poolsupplies.com](http://www.poolsupplies.com), [www.poolsupplies.com](http://www.poolsupplies.com), Sep. 9, 2015, <https://www.poolsupplies.com/product/commercial-series-vacuum-pole-7-21>.
- Screenshots from [www.poolsupplies.com](http://www.poolsupplies.com), [www.poolsupplies.com](http://www.poolsupplies.com), Sep. 9, 2015, <https://www.poolsupplies.com/product/telescoped-vacuum-pole-2>.
- Screenshots from [www.woosterbrush.com](http://www.woosterbrush.com), The Wooster Brush Company, Sep. 10, 2015, <http://www.woosterbrush.com/other-tools/extension-poles/sherlock-pole/>.
- Screenshots from [www.woosterbrush.com](http://www.woosterbrush.com), The Wooster Brush Company, Sep. 10, 2015, <http://www.woosterbrush.com/other-tools/extension-poles/sherlock-gt-javelin/>.
- Screenshots from [www.woosterbrush.com](http://www.woosterbrush.com), The Wooster Brush Company, Sep. 10, 2015, <http://www.woosterbrush.com/other-tools/extension-poles/sherlock-gt-convertible/>.
- Screenshot from [www.inyopools.com](http://www.inyopools.com)/Products/00101349003342.htm, INYO Pools.com, Sep. 9, 2015.
- Screenshot from [www.inyopools.com](http://www.inyopools.com)/Products/23301349061755.htm, INYO Pools.com, Sep. 9, 2015.
- Screenshots from [www.mkm-poolspa.com](http://www.mkm-poolspa.com)/maintenance-equipment/?sort=featured&page=2, MKM Pool Spa, Inc., Sep. 9, 2015.
- Screenshots from [www.mkm-poolspa.com](http://www.mkm-poolspa.com)/maintenance-equipment/?sort=featured&page=3, MKM Pool Spa, Inc., Sep. 9, 2015.
- Screenshot from [www.watertechcorp.com](http://www.watertechcorp.com)/products-SpaVac.htm, Water Tech Corp, Sep. 9, 2015.
- Screenshot from [www.watertechcorp.com](http://www.watertechcorp.com)/products-aquabroom.htm, Water Tech Corp, Sep. 9, 2015.
- Screenshot from [www.watertechcorp.com](http://www.watertechcorp.com)/products-AquaBroomXL.htm, Water Tech Corp, Sep. 9, 2015.
- Screenshot from [www.watertechcorp.com](http://www.watertechcorp.com)/products-cattfish.htm, Water Tech Corp, Sep. 9, 2015.
- Screenshot from [www.watertechcorp.com](http://www.watertechcorp.com)/products-cattfish-ultra.htm, Water Tech Corp, Sep. 9, 2015.
- Screenshot from [www.watertechcorp.com](http://www.watertechcorp.com), Water Tech Corp, Sep. 9, 2015, <http://www.watertechcorp.com/products-PBmax.htm>.
- Screenshot from [www.watertechcorp.com](http://www.watertechcorp.com), Water Tech Corp, Sep. 9, 2015, <http://www.watertechcorp.com/products-PBmaxCG.htm>.
- Screenshot from [www.watertechcorp.com](http://www.watertechcorp.com), Water Tech Corp, Sep. 9, 2015, <http://www.watertechcorp.com/products-PBmaxIID.htm>.
- Screenshot from [www.watertechcorp.com](http://www.watertechcorp.com), Water Tech Corp, Sep. 9, 2015, <http://www.watertechcorp.com/products-PBCentennial.htm>.
- Screenshot from [www.watertechcorp.com](http://www.watertechcorp.com), Water Tech Corp, Sep. 9, 2015, <http://www.watertechcorp.com/products-IVAC-aquabroom.htm>.
- Screenshot from [www.watertechcorp.com](http://www.watertechcorp.com), Water Tech Corp, Sep. 9, 2015, <http://www.watertechcorp.com/products-IVAC-C2.htm>.
- Product photos of AquaEZ Compression Lever Telescopic Pole, [www.aquaez.com](http://www.aquaez.com), Sep. 10, 2015.
- Product photos of Ettore extension pole, [www.ettore.com](http://www.ettore.com), Sep. 10, 2015.
- Product photos of Everlok extension pole, <http://linzerproducts.net/index.php/products>, Sep. 10, 2015.
- Product photos of Mr. Long Arm Button Lock extension pole, [www.mrlongarm.com](http://www.mrlongarm.com), Sep. 10, 2015.
- Product photos of Mr. Long Arm extension pole with compression nut locking device, [www.mrlongarm.com](http://www.mrlongarm.com), Sep. 10, 2015.
- Product photos of Ocean Blue extension pole with internal cam locking device, [www.oceanbluewaterproducts.com](http://www.oceanbluewaterproducts.com), Sep. 10, 2015.
- Product photos of Ocean Blue extension pole with compression nut locking device, [www.oceanbluewaterproducts.com](http://www.oceanbluewaterproducts.com), Sep. 10, 2015.
- Product photos of Oreq Gorilla pole, [oreqcorp.com/maintenance/xpoles.asp](http://oreqcorp.com/maintenance/xpoles.asp), Sep. 10, 2015.
- Product photos of Oreq Sterling pole, [oreqcorp.com/maintenance/xpoles.asp](http://oreqcorp.com/maintenance/xpoles.asp), Sep. 10, 2015.
- Product photos of Quickie extension pole, [www.quickie.com/Products/potherproducts](http://www.quickie.com/Products/potherproducts), Sep. 10, 2015.
- Product photos of Shur-Line extension pole, [www.home depot.com/p/Shur-Line-Easy-Reach-60-in-Adjustable-Extension-Pole-06570U100534761](http://www.home depot.com/p/Shur-Line-Easy-Reach-60-in-Adjustable-Extension-Pole-06570U100534761), Sep. 10, 2015.
- Product photos of Skimlite 5009 Series extension pole, [www.skimlite.com/poles.html](http://www.skimlite.com/poles.html), Sep. 10, 2015.
- Product photos of Skimlite Dually Series extension pole, [www.skimlite.com/poles.html](http://www.skimlite.com/poles.html), Sep. 10, 2015.
- Product photos of Skimlite Elliptlock extension pole, [www.skimlite.com/poles.html](http://www.skimlite.com/poles.html), Sep. 10, 2015.
- Product photos of Unger extension pole, [www.ungerglobal.com/retail/en/](http://www.ungerglobal.com/retail/en/), Sep. 10, 2015.
- Product photos of Wooster Sherlock extension pole, [www.woosterbrush.com/other-tools/extension-poles/sherlock-pole/](http://www.woosterbrush.com/other-tools/extension-poles/sherlock-pole/), Sep. 10, 2015.
- Product photos of Z-Pro wooden extension pole, [www.premierpaintroller.com](http://www.premierpaintroller.com), Sep. 10, 2015.
- Piranha Power Pole Review, Wine Country Pools and Supplies, [www.WineCountryPoolsOnline.com](http://www.WineCountryPoolsOnline.com), Apr. 1, 2014.
- Piranha Power Pole Review Update, Wine Country Pools and Supplies, [www.WineCountryPoolsOnline.com](http://www.WineCountryPoolsOnline.com), Jan. 25, 2015.
- Transmittal document regarding product samples sent to Examiner on Nov. 4, 2015 for review, as also filed with the USPTO on Nov. 12, 2015.
- Photos of the above-referenced non-applicant products shipped to the Examiner on Nov. 4, 2015: First Choice Cam Lock Pole.
- Photos of the above-referenced non-applicant products shipped to the Examiner on Nov. 4, 2015: Skim Lite Dually Cam Lock Pole.
- Photos of the above-referenced non-applicant products shipped to the Examiner on Nov. 4, 2015: Lion Cam Lock Pole.
- Photo of the above-referenced non-applicant products shipped to the Examiner on Nov. 4, 2015: AquaEZ Cam Lock Pole.
- Photo of the above-referenced non-applicant products shipped to the Examiner on Nov. 4, 2015: Shur-Line Painter's Pole.
- Photo of the above-referenced non-applicant products shipped to the Examiner on Nov. 4, 2015: Wooster Sherlock Painter's Pole.
- Photo of the above-referenced non-applicant products shipped to the Examiner on Nov. 4, 2015: Generic Paint Roller.
- Photos of the above-referenced Applicant's current product samples.
- Photos of the above-referenced Applicant's current product samples shipped to the Examiner on Nov. 4, 2015: RFSH Piranha Power Pole.
- Photos of the above-referenced Applicant's current product samples shipped to the Examiner on Nov. 4, 2015: RESII Cut Power Pole.
- Photos of the above-referenced Applicant's current product samples shipped to the Examiner on Nov. 4, 2015: RESH Piranha Net.
- Photos of the above-referenced Applicant's current product samples shipped to the Examiner on Nov. 4, 2015: RESH Piranha Cam-Lock Pole.
- Screenshot from [www.lowes.com](http://www.lowes.com), <https://www.lowes.com/pl/Pool-poles-Pool-maintenance-equipment-Pool-maintenance-Pools-hot-tubs-Outdoors/4294610211?searchTerm=pool+poles>, Apr. 6, 2017.
- Screenshot from PEP TX Facebook page, <https://www.facebook.com/GOPEPTX>, Dec. 15, 2016.
- Lowe's website with a LIVE chat today Dec. 15, 2016; <https://www.lowes.com/pl/Pool-poles-Pool-maintenance-equipment-Pool-maintenance-Pools-hot-tubs-Outdoors/4294610211>, Dec. 15, 2016.
- Screenshot from YouTube.com featuring a "As Seen On TV" video of Stringray Nets and Poles; <https://www.youtube.com/watch?v=Xqxb-S2rOyk>, published Oct. 21, 2016.
- Article "Pool Pros: Here's How to Get a Grip on Hand and Wrist Pain" by Nate Traynor from PoolSpaNews.com; [http://www.poolspanews.com/how-to/maintenance/pool-pros-heres-how-to-get-a-grip-on-hand-and-wrist-pain\\_0](http://www.poolspanews.com/how-to/maintenance/pool-pros-heres-how-to-get-a-grip-on-hand-and-wrist-pain_0); featuring Eric Resh's Stingray Pole, published Jul. 17, 2017.
- Screenshot from [www.aquaez.com](http://www.aquaez.com), AquaEZ Poles Page, <http://www.aquaez.com/products/poles/>, Apr. 6, 2017.
- Declaration of Dennis R. Olmack, dated Nov. 4, 2019.
- Document No. 19; Declaration of Barrett Conrad in Support of Defendant's Motion to Dismiss, dated Mar. 30, 2018 from CACD:5:18-cv-00291-JGB-KK; *Resh, Inc. v. Skimlite Manufacturing*.
- Document No. 21-1; Declaration of Eric Resh in Support of Plaintiff's Opposition to Defendant's Motion to Dismiss, dated Apr. 9, 2018 from CACD:5:18-cv-00291-JGB-KK; *Resh, Inc. v. Skimlite Manufacturing*.
- Declaration of Dave Goulart, dated Feb. 27, 2018.
- Declaration of Dan Cavender, dated Oct. 14, 2019.
- Declaration of Kristen MacDowell, dated Mar. 4, 2018.

US 11,141,852 B2

Page 4

(56)

References Cited

OTHER PUBLICATIONS

Reporter's Transcript of *Resh, Inc. V. Skimlite Manufacturing, Inc.*, Oral Proceedings of Barrett Conrad, dated Monday, Apr. 30, 2018.

Poolman Dave Blog; <https://poolmandave.blogspot.com>; Oct. 14, 2019.

Pro Tuff Products; Important Pro Tuff "Ultimate Series" Pool Pole Info; [https://www.amazon.com/vdp/2d7a6c66e99744129f7385b6dad41814?ref=dp\\_vse\\_rvc0](https://www.amazon.com/vdp/2d7a6c66e99744129f7385b6dad41814?ref=dp_vse_rvc0); Oct. 14, 2019.

Lowe's; <https://www.lowes.com/pd/Aqua-F/-2-piece-telescopic-16-ft-Aluminum-Pool-Pole/1000178657>; Apr. 14, 2017.

Pool and Spa News; Pool Pros: Here's How to Get a Grip on Hand and Wrist Pain by Nate Traylor; [https://www.poolspanews.com/how-to/maintenance/pool-pros-heres-how-to-get-a-grip-on-hand-and-wrist-pain\\_o](https://www.poolspanews.com/how-to/maintenance/pool-pros-heres-how-to-get-a-grip-on-hand-and-wrist-pain_o); Jul. 17, 2017.

"As Seen On TV" promotions; TSC—StingRay Nets & Poles; <https://youtu.be/Xqxb-S2rOyk>; Oct. 21, 2016.

The Smart Company; Stingray Nets and Poles; <https://stingraynets.com/>; Oct. 14, 2019.

Skimlite.com; <https://skimlite.com/5000-series/>; Oct. 14, 2019.

Pro Tuff Products; <https://www.protuffproducts.com/>; Oct. 14, 2019.

Web.archive.com: Skimlite.com—Skimlite History; [https://web.archive.org/web/20180819015010/http://www.skimlite.com/history\\_page.html](https://web.archive.org/web/20180819015010/http://www.skimlite.com/history_page.html); Oct. 14, 2019.

Declaration of Rod MacDowell, dated Mar. 4, 2018.

Declaration of Eric Resh, dated Oct. 16, 2019.

\* cited by examiner

1  
2  
3  
4  
5  
6  
7  
8  
9  
10  
11  
12  
13  
14  
15  
16  
17  
18  
19  
20  
21  
22  
23  
24  
25  
26  
27  
28

U.S. Patent

Oct. 12, 2021

Sheet 1 of 16

US 11,141,852 B2

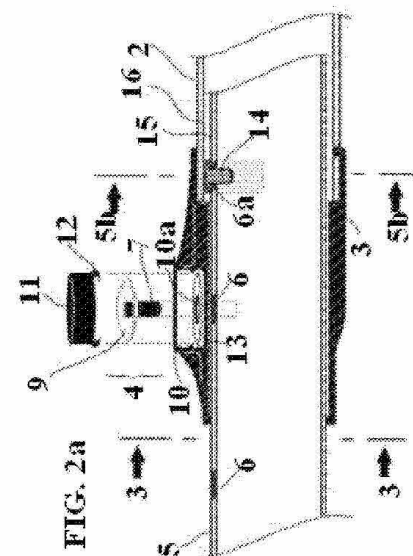
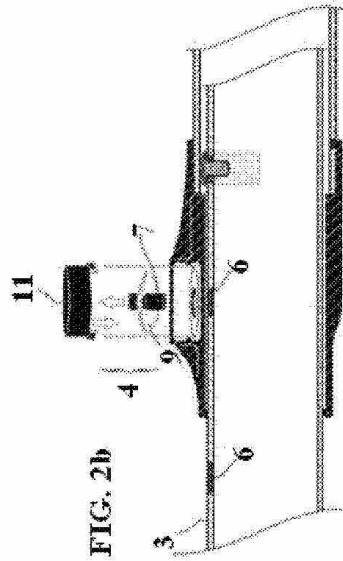
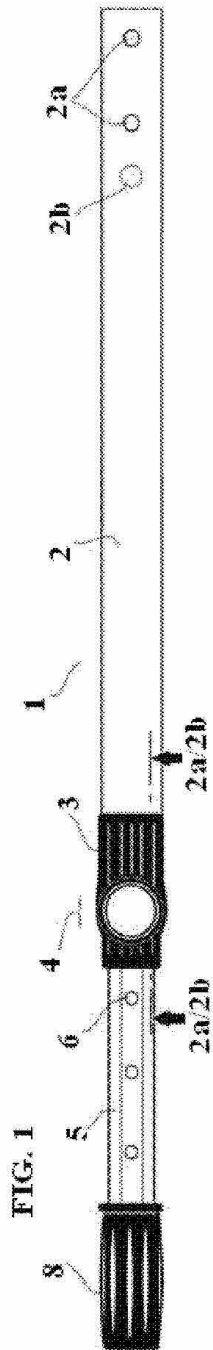

1  
2  
3  
4  
5  
6  
7  
8  
9  
10  
11  
12  
13  
14  
15  
16  
17  
18  
19  
20  
21  
22  
23  
24  
25  
26  
27  
28

U.S. Patent

Oct. 12, 2021

Sheet 2 of 16

US 11,141,852 B2

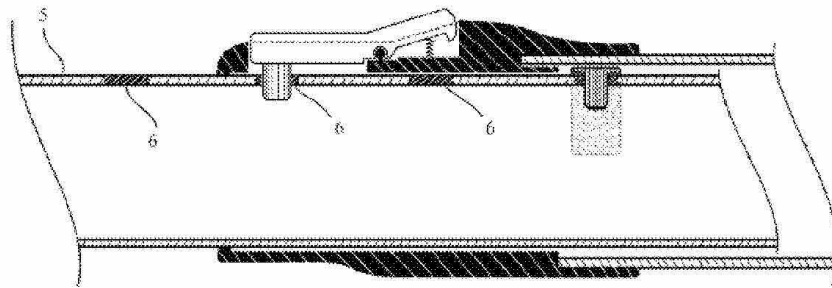

FIG. 2c

1  
2  
3  
4  
5  
6  
7  
8  
9  
10  
11  
12  
13  
14  
15  
16  
17  
18  
19  
20  
21  
22  
23  
24  
25  
26  
27  
28

U.S. Patent

Oct. 12, 2021

Sheet 3 of 16

US 11,141,852 B2

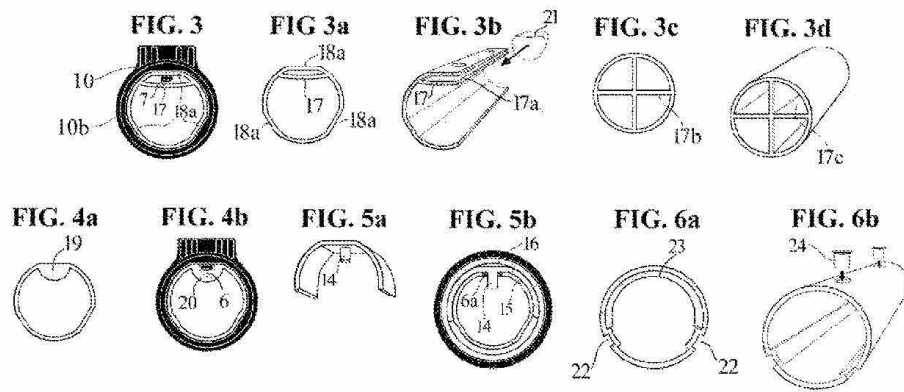

1  
2  
3  
4  
5  
6  
7  
8  
9  
10  
11  
12  
13  
14  
15  
16  
17  
18  
19  
20  
21  
22  
23  
24  
25  
26  
27  
28

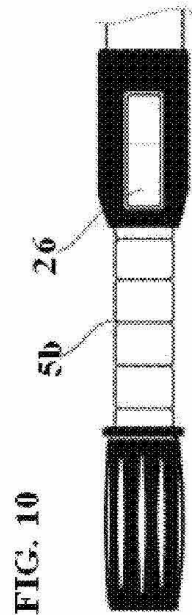
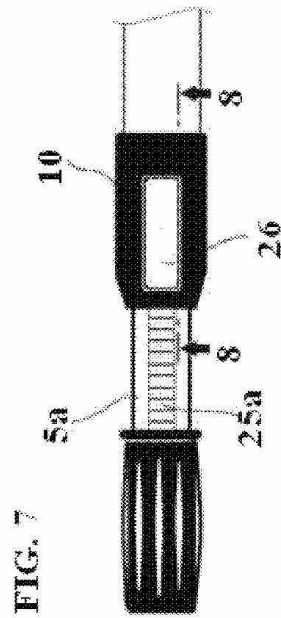
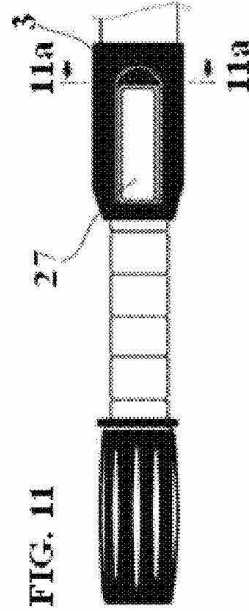
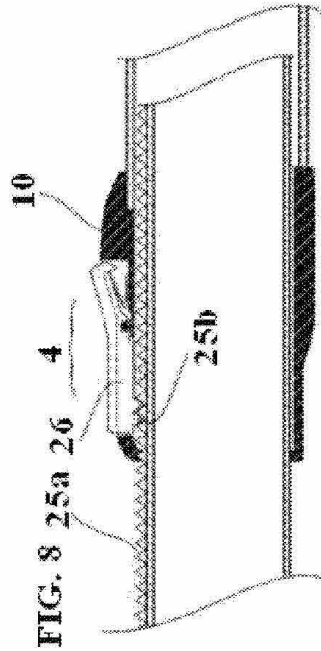

1  
2  
3  
4  
5  
6  
7  
8  
9  
10  
11  
12  
13  
14  
15  
16  
17  
18  
19  
20  
21  
22  
23  
24  
25  
26  
27  
28



U.S. Patent

Oct. 12, 2021

Sheet 5 of 16

US 11,141,852 B2

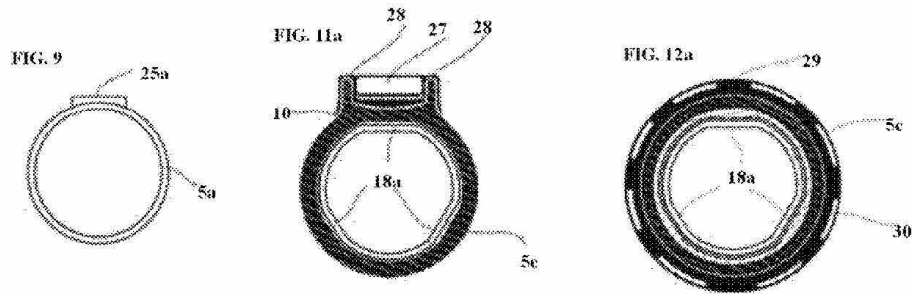

1  
2  
3  
4  
5  
6  
7  
8  
9  
10  
11  
12  
13  
14  
15  
16  
17  
18  
19  
20  
21  
22  
23  
24  
25  
26  
27  
28

U.S. Patent

Oct. 12, 2021

Sheet 6 of 16

US 11,141,852 B2

FIG. 12

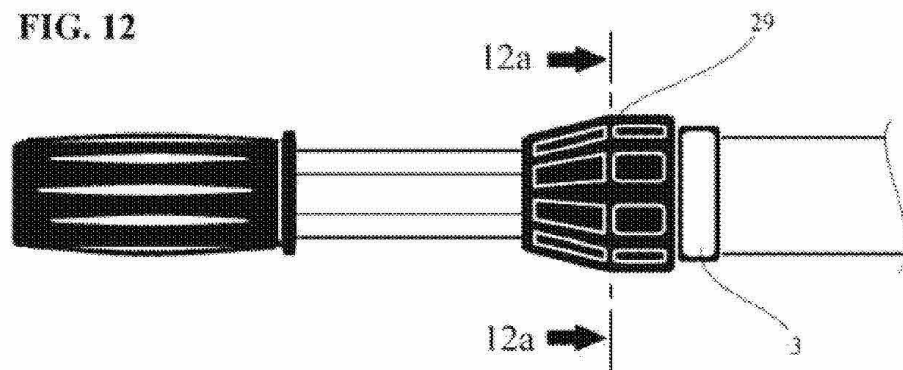

1  
2  
3  
4  
5  
6  
7  
8  
9  
10  
11  
12  
13  
14  
15  
16  
17  
18  
19  
20  
21  
22  
23  
24  
25  
26  
27  
28

U.S. Patent

Oct. 12, 2021

Sheet 7 of 16

US 11,141,852 B2

FIG. 12b

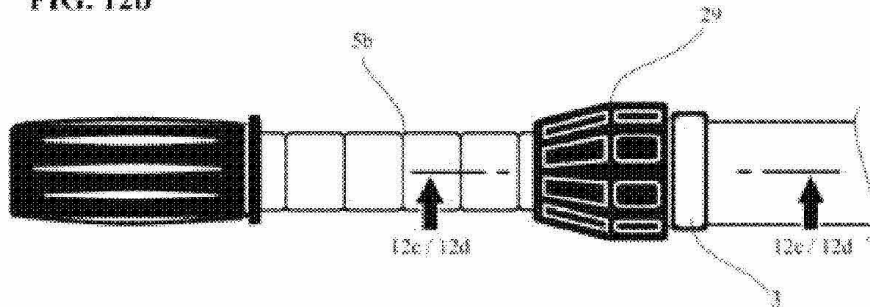

FIG. 12c

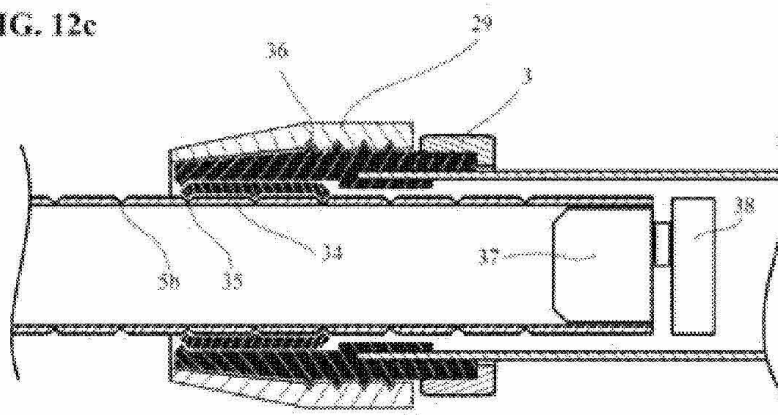
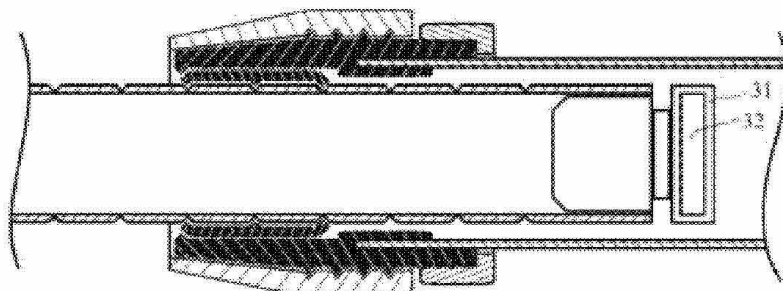

FIG. 12d



1  
2  
3  
4  
5  
6  
7  
8  
9  
10  
11  
12  
13  
14  
15  
16  
17  
18  
19  
20  
21  
22  
23  
24  
25  
26  
27  
28

FIG. 13a

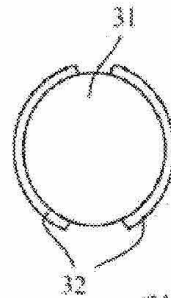

FIG. 13b

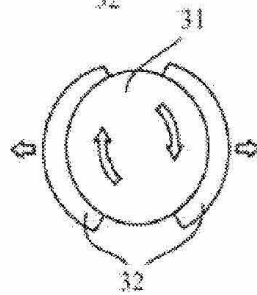

FIG. 13c

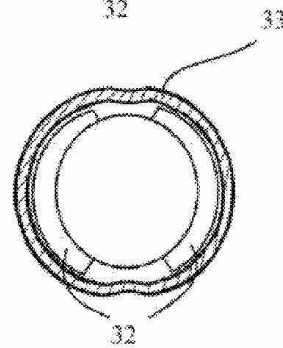
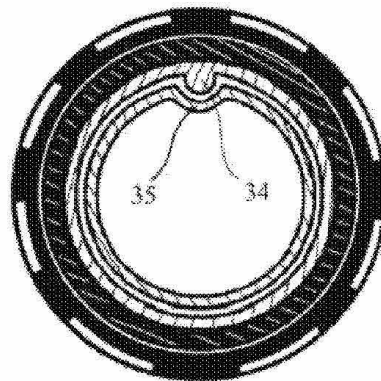

FIG. 14



1  
2  
3  
4  
5  
6  
7  
8  
9  
10  
11  
12  
13  
14  
15  
16  
17  
18  
19  
20  
21  
22  
23  
24  
25  
26  
27  
28

U.S. Patent

Oct. 12, 2021

Sheet 9 of 16

US 11,141,852 B2

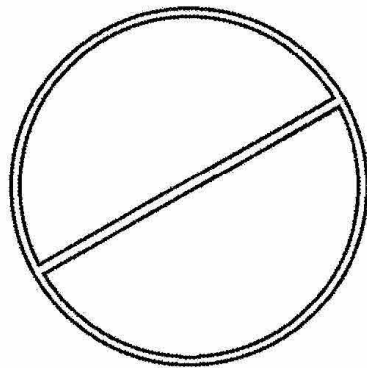

FIG. 15a

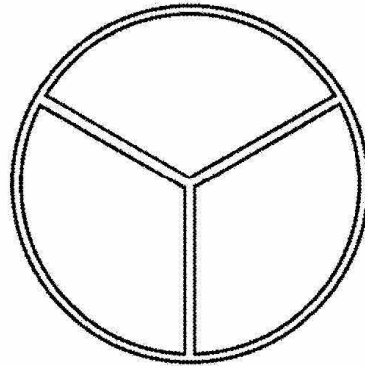

FIG. 15b

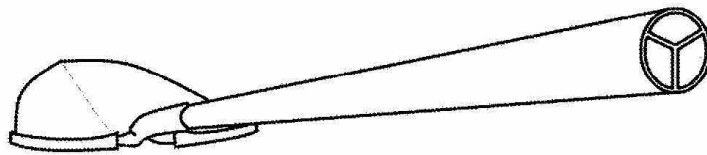

FIG. 16a



FIG. 16b

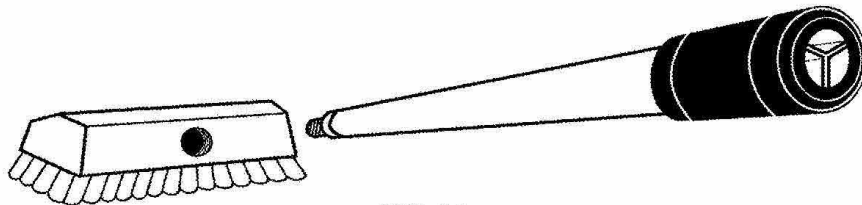

FIG. 17

1  
2  
3  
4  
5  
6  
7  
8  
9  
10  
11  
12  
13  
14  
15  
16  
17  
18  
19  
20  
21  
22  
23  
24  
25  
26  
27  
28

U.S. Patent

Oct. 12, 2021

Sheet 10 of 16

US 11,141,852 B2

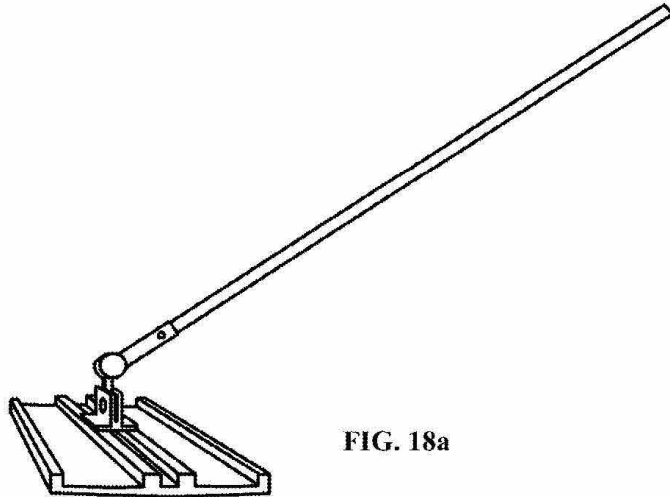

FIG. 18a

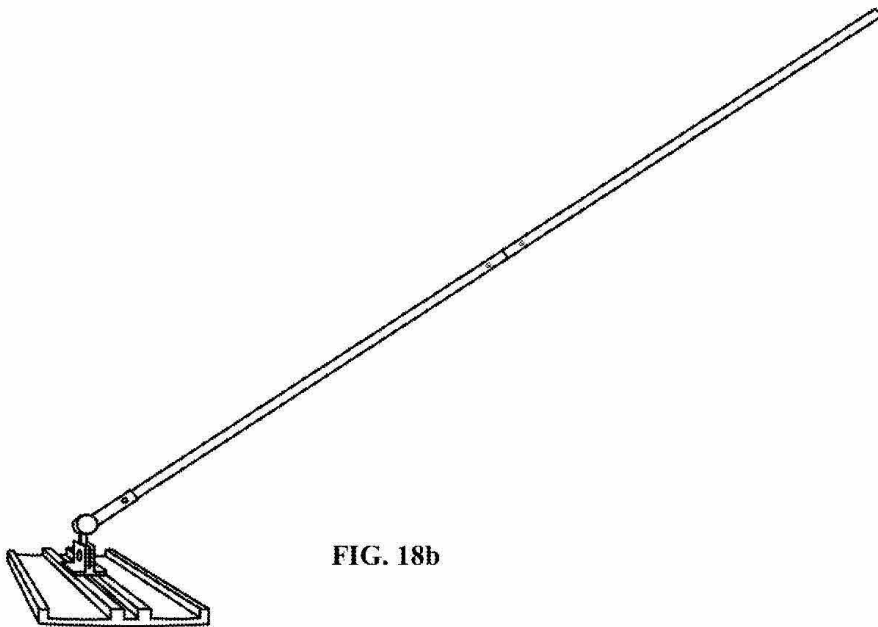

FIG. 18b

1  
2  
3  
4  
5  
6  
7  
8  
9  
10  
11  
12  
13  
14  
15  
16  
17  
18  
19  
20  
21  
22  
23  
24  
25  
26  
27  
28

U.S. Patent Oct. 12, 2021 Sheet 11 of 16 US 11,141,852 B2

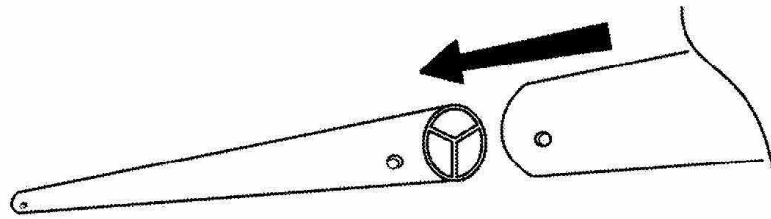

FIG. 18c

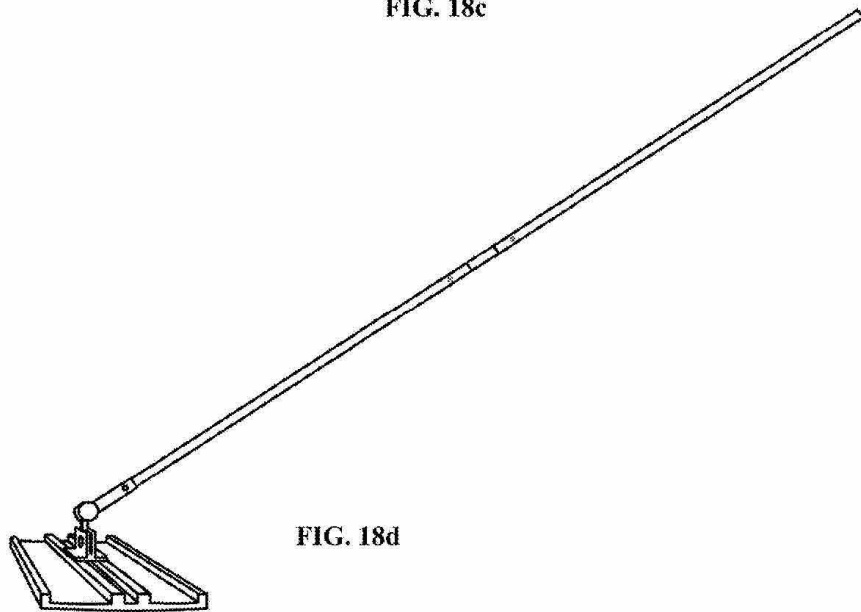

FIG. 18d

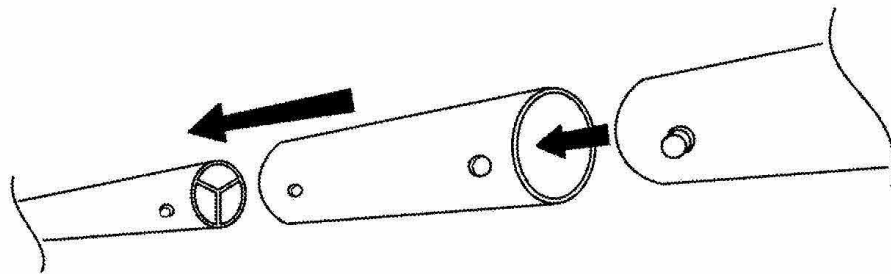

FIG. 18e

1  
2  
3  
4  
5  
6  
7  
8  
9  
10  
11  
12  
13  
14  
15  
16  
17  
18  
19  
20  
21  
22  
23  
24  
25  
26  
27  
28

U.S. Patent

Oct. 12, 2021

Sheet 12 of 16

US 11,141,852 B2

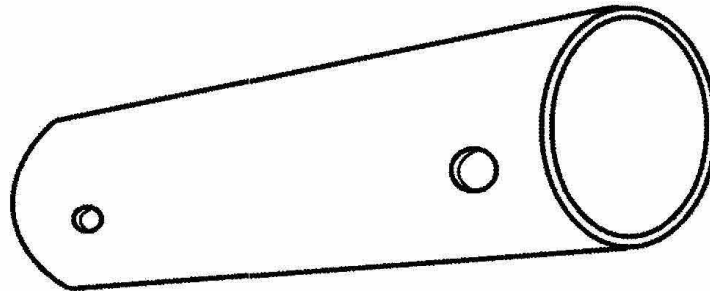

FIG. 19a

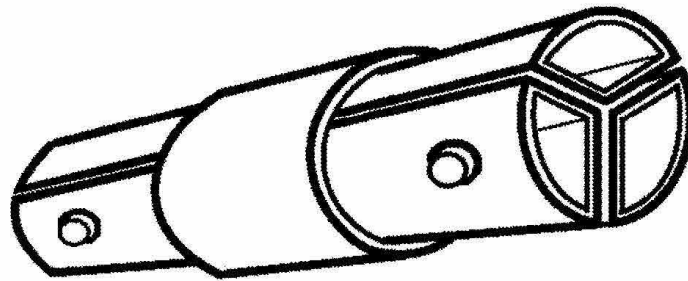

FIG. 19b

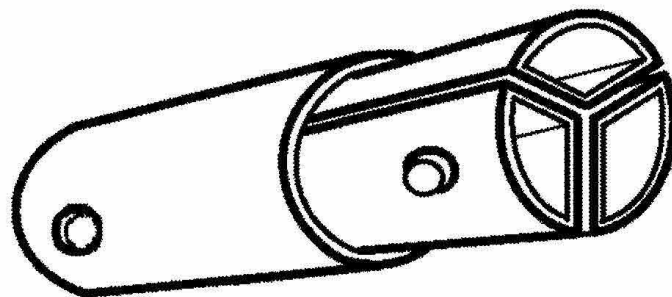

FIG. 19c

1  
2  
3  
4  
5  
6  
7  
8  
9  
10  
11  
12  
13  
14  
15  
16  
17  
18  
19  
20  
21  
22  
23  
24  
25  
26  
27  
28



U.S. Patent

Oct. 12, 2021

Sheet 13 of 16

US 11,141,852 B2

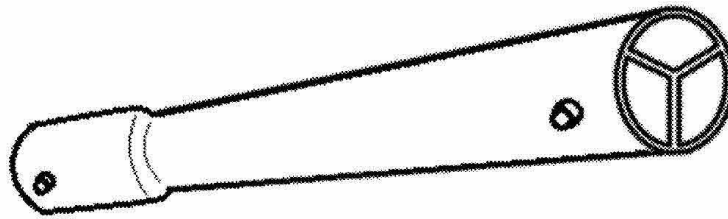

FIG. 20



FIG. 21

1  
2  
3  
4  
5  
6  
7  
8  
9  
10  
11  
12  
13  
14  
15  
16  
17  
18  
19  
20  
21  
22  
23  
24  
25  
26  
27  
28

U.S. Patent

Oct. 12, 2021

Sheet 14 of 16

US 11,141,852 B2

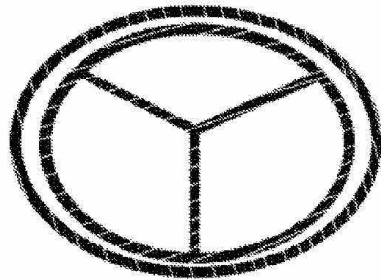

FIG. 22

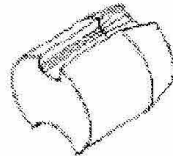

FIG. 23a



FIG. 23b

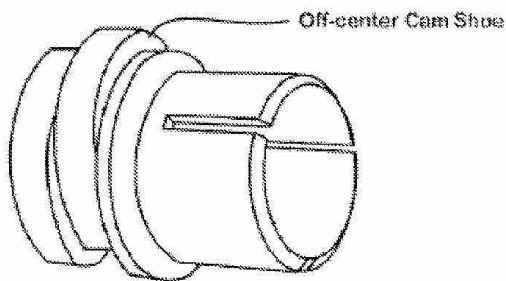

FIG. 24a

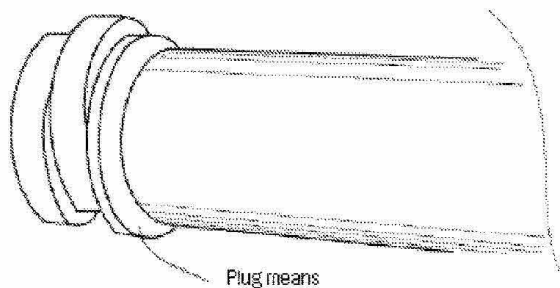

FIG. 24b

1  
2  
3  
4  
5  
6  
7  
8  
9  
10  
11  
12  
13  
14  
15  
16  
17  
18  
19  
20  
21  
22  
23  
24  
25  
26  
27  
28

U.S. Patent

Oct. 12, 2021

Sheet 15 of 16

US 11,141,852 B2

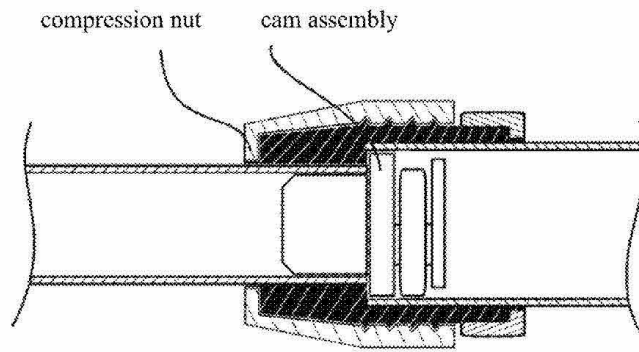

FIG. 24c

1  
2  
3  
4  
5  
6  
7  
8  
9  
10  
11  
12  
13  
14  
15  
16  
17  
18  
19  
20  
21  
22  
23  
24  
25  
26  
27  
28

**U.S. Patent**

Oct. 12, 2021

Sheet 16 of 16

**US 11,141,852 B2**

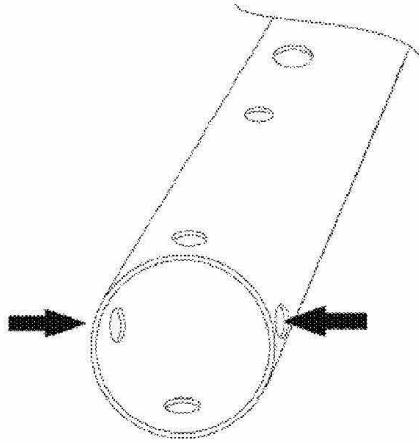

**FIG. 25**

1  
2  
3  
4  
5  
6  
7  
8  
9  
10  
11  
12  
13  
14  
15  
16  
17  
18  
19  
20  
21  
22  
23  
24  
25  
26  
27  
28

US 11,141,852 B2

**1**  
**TELEPOLE APPARATUS AND RELATED METHODS**

CROSS-REFERENCE TO RELATED APPLICATIONS

This application claims priority to U.S. Provisional Application Ser. No. 61/538,074, filed Sep. 22, 2011, the disclosure of which is incorporated herein by reference in its entirety.

This continuation-in-part application claims priority to U.S. patent application Ser. No. 13/624,702, filed on Sep. 21, 2012 and Ser. No. 13/844,561 filed on Mar. 15, 2013, both of which were based on U.S. Provisional Application Ser. No. 61/538,074, filed Sep. 22, 2011, the disclosures of which are incorporated herein by reference in their entirety.

FIELD OF THE INVENTION

This invention relates to devices for cleaning swimming pools and similar things, and more specifically is directed to apparatus and methods involving an improved telescopic pole useful for (among other things) attachment to swimming pool cleaning tools.

BACKGROUND OF THE INVENTION

Many prior art tools are made with extendable handles which serve at least three key functions, among others: they provide a means for a user to grip the tool, they increase extension and reach, and they create leverage. For example, a typical shovel has a pan-shaped head for digging and/or moving dirt. An extendable handle attached to the shovel head allows a user to work in a standing position and keep their hands at a reasonable distance from the work being done (rather than bending/kneeling/etc. down to get close to the work), and it further enables a user to create leverage when prying or scooping with the shovel. An array of hand tools such as hammers, rakes, brushes, scrapers, mops, concrete finishing tools, etc. use extendable handles for similar reasons.

Some of the problems with prior art extendable handles, however, are associated with the failure of the handles to perform adequately during use. It is not uncommon for wooden handles on shovels and other leveraging tools to break under the normal pressure that occurs during use. Sometimes manufacturers use harder woods to reduce such breakage; however, hard woods tend to weigh more than softer woods and consequently, make the tools heavier. Handles made of metal tubes are often used, but these may likewise be heavy or bend when under pressure. It is also common for handles on shovels, rakes, brooms, etc. to be made from synthetic materials such as plastic or fiberglass; such handles likewise may be heavy, lack strength or fail for other reasons.

One such area where extendable handles are very useful, if not essential, is for use with swimming pool cleaning tools (so that a user does not have to get in the water when cleaning a pool or similar water feature, but can reach the water from a standing position on a deck/dry place). A wide variety of tools and processes have been developed for use with swimming pool cleaning tools to clean pools and similar things (fountains, spas—both above and below ground, fish ponds, etc.). Among those devices and methods are devices that are commonly referred to as “telepoles”.

**2**

Other uses for such “telepoles” include window washing tools, paint rolling tools, and concrete spreading/finishing tools.

Specifically within the concrete industry, telescopic poles and/or extending handles are attached to trowels and floats for finishing large/wide/etc. slabs of concrete that could not otherwise be reached without the user having to step in the wet concrete. With extendable/telescopic handles, tubular sections of handle can be attached one after the other to reach 20 to 30 feet, or even more. However, handles of this length may easily sag in the middle between the user and the tool, and manufacturers have attempted to reduce sagging by increasing the diameter and thickening the walls of the tubular sections. In doing so, they use a greater amount of material (typically aluminum within the concrete industry) and, consequently, make the handles heavier and more difficult to work with.

Commonly, telepoles utilize two separate lengths of tubing (configured so that one slides within the other to adjust the overall length of the telepole, and a mechanism or device which “locks” the tubes together at a desired position (so that, while so locked, they do not move/slide with respect to one another). That desired position (in effect, the selected length of the telepole) depends on a number of factors, such as the depth of the pool, the strength of the person using the tool, the particular tool being used, etc. Further, a selected telepole or handle length may be made even longer by adding one or more additional lengths of tubing in a series so that each length contributes to an overall desired length.

Typically, telepole tubing is made from aluminum, fiberglass, or some other light, yet relatively strong material. Generally, in telepoles used for attaching swimming pool cleaning tools, the lower tube (nearest the attached tool) is the “outer” tube, and the upper tube reciprocates within that lower tube. The lower/outer tube typically has a collar-like element at one end and a series of holes near and/or along a portion of the opposite end. The collar means provides a finished end of the tube which receives the inner/upper tube and also serves as a guide to keep the inner/upper tube well-positioned/aligned as it slides within the outer tube. The holes along the opposite end commonly serve several purposes, such as providing attachment means for attaching swimming pool cleaning tools and allowing water to enter and exit the tube, so that the tool will fill with water to some degree during use (making it easier to keep the tool in contact with the bottom of the pool, instead of having it float up off the bottom) and the water can drain from the tube upon removal of the pole/tool from the water.

Typically, a first set of holes is positioned closest to the end of the outer tube (approximately one inch from the end of the pole), consisting of two holes placed on opposite sides of the tube (180 degrees from each other about the tube’s circumference). A few inches farther away from the “tool end” of the pole/tube, a second set of two holes commonly is positioned similarly about the tube’s circumference, and a third set may be even further from the “tool end” of the pole. The first set of holes nearest the end of the tube are positioned and configured to allow easy attachment and removal of pool cleaning tools such as leaf nets, brushes, vacuum heads, and the like, by using springy plastic “V-clips” having button-like ends that extending outwardly through the first set of holes (typically after also extending from the interior of the tool through corresponding holes in the tool sidewall). Thus, the first set of holes typically act as receiving holes for receiving V-clip buttons, where the V-clip is operably positioned on the attachment end of a pool cleaning tool.

US 11,141,852 B2

3

4

The second set of distally located holes are commonly used for mounting various tools such as lifesaving rescue hooks that require more permanent attachment to the telepole. A third set of holes may be positioned similarly to the first and second sets about the tube's circumference and located even farther from the tube's end than the first or second sets of holes, to enable water to more easily enter into (and/or drain from) the interior of the outer pole/tube.

In many prior art telepoles used for attaching pool cleaning tools, the inner/upper tube is of similar length to the outer tube and has a profile with a smaller circumference than that of the outer tube, in order to permit sliding of the inner tube within the outer tube. The inner/upper tube commonly has a gripping element mounted on one end which provides a gripping surface for a user to grasp the end of the telepole. The gripping element also serves to prevent the inner tube from sliding completely into the outer tube and becoming ungraspable. The opposite end of the inner tube is received by the collar means of the outer/lower tube. Commonly, the end of the inner/upper tube that reciprocates within the outer tube has a cam-like element which serves as an internal pressure locking device to "lock" the inner tube in place within the outer tube.

Essentially, when the inner/upper tube is rotated so that the cam element is aligned with the profile of the inside walls of the outer tube, the inner tube can freely slide within the outer tube (since the cam element does not engage with or apply pressure on the inside walls of the outer tube in this position). However, when the user sufficiently further rotates the inner tube with respect to the outer tube, the inner tube's cam element becomes misaligned with the profile of the inner walls of the outer/lower tube, and the cam element applies a pressure against the inner walls of the outer tube and "locks" the inner tube in place within the outer tube. In this way, the inner tube may be manipulated and positioned (and locked) at a desired position along the length of the outer tube, thereby selectively setting the length of the telepole device.

Other prior art telepole devices utilize an external locking device in which a portion of the collar element on the outer tube acts as a compression fitting. In these devices, an end of the collar element is elongated with male threads and is sometimes capable of expanding and contracting across its diameter. A corresponding female threaded compression ring fits around the male threaded end, and a compression gasket fits at least partially between the male end and the inner tube. The compression ring usually has gripping textures to add grip for a user's hands which may be wet and slippery from pool water. The telepole is locked into a desired position by twisting the compression ring to tighten it to the collar and simultaneously squeezing the gasket against the outside surface of the inner tube. With sufficient pressure, the telepole will generally stay "locked" in the desired position. Loosening the compression ring reduces pressure on the gasket and allows the inner tube to slide freely again.

Further examples of prior art telepole locking devices include U.S. Pat. No. 5,729,865, which has a sliding locking assembly for retaining the tubes in position relative to one another; and U.S. Patent Application No. 2006/0230581, which has rotatable locking mechanism wherein rotation of a locking segment on the outer tube creates frictional locking engagement with the inner tube.

Other prior art telepoles used to clean swimming pools have both internal and external locking devices, and some even have multiple locks of either type and/or a combination of the two types. For example, some have three tubes, each

with a profile of a different circumference such that they fit within each other: an outer tube with an external locking device and tool attachment holes, a middle tube with an external locking device, and an inner tube with an internal locking device and a grip.

The various prior art telepole configurations discussed above have shortcomings. Among other things, the cam element's locking ability may lessen or diminish over time. Repeated use results in wear and tear on the cam and/or the inner walls of the outer tube, causing the contact surfaces of the cam and inner walls to become rough and/or out of round. As a result, a cam may lose its ability to become misaligned with the inner walls of the tube and as a consequence the inner and outer tubes cannot be "locked" in place with respect to each other. In this situation, the cam may also spontaneously align itself with the inner walls of the tube, thus permitting the tubes to readily slide past one another and causing the telepole to collapse/slip when pressure is applied to it during cleaning. The tendency of the cam to spontaneously align with the inner walls may also result in tool failure and even poses the risk of the user falling into the pool if the telepole suddenly collapses while the user is applying pressure to it.

Further, prior art telepoles are prone to bending/becoming deformed during use due to the amount of pressure/weight applied to them by a user. In time, the tubes may no longer be true (aligned with each other). When this happens, the telepole's internal locking devices tend to jam in the areas where the tubes are out of round and/or not straight, resulting in complete failure of the telescopic feature of the pole. In other words, and among other things, poles in this condition may not be extendable or adjustable in length.

Additionally, prior art external locking devices are subject to wear and tear in prior art telepole devices. Over time, the contacting surfaces can wear and/or become smooth and have less friction, which greatly reduces the ability of the compression ring to hold the inner tube in place. In some cases, this allows the inner tube to slide within the outer tube even when the outer ring is tightened to its maximum position. The inner tube may also undesirably rotate when the telepole is in use, thus reducing the user's ability to maneuver the attached cleaning tools as desired. Furthermore, telepoles having only an external locking device have the additional problem of water filling the inner tube during use since there is no cam to plug the end of the inner tube. This can make the telepole very heavy and less maneuverable (as mentioned above, some water inside the tube(s), such as in the lower tube, can be helpful in using the tool, but too much water can be a substantial problem or inconvenience in using the tool). Even further, new prior art telepoles having new compression rings have been known to undesirably permit inner tube rotating and/or sliding within the outer tube.

Attempts to remedy these known issues/problems have led to even more problems. One such attempt increases the tightening force of the compression ring, but it can make the compression ring very difficult to loosen and painful to the user's hands to twist the compression ring either to tighten or loosen it.

The issues described above are common among prior art telepoles used to clean swimming pools and have led to the creation of telepoles with both internal and external locking devices, wherein either device may serve as a backup for the other. The Elipollock pole made by Skimlite is a further attempt to avert the problems discussed above. Both the inner and outer tubes of an Elipollock pole have similar elliptical profiles, with the inner tube being slightly smaller

US 11,141,852 B2

5

than the outer tube; and the inner tube sliding freely when its profile is aligned with the profile of the outer tube. A slight twist from the user causes the inner tube to become wedged within the outer tube and "locked" in place. A twist in the opposite direction releases the inner tube so that its profile is aligned with that of the outer tube and it may freely slide within the outer tube. Over time, however, the areas of contact between the tubes become rough and develop friction, and the inner tube may become jammed within the outer tube. This is especially common when the telepole bends or changes shape due to various pressures placed upon it during use.

Further, "telepoles" or extendable handles used in other applications are not necessarily suitable for use in swimming pools. In window washing, painting, or marine applications, for example, telepole configurations are basically the opposite of those needed for cleaning swimming pools. The grip discussed above is mounted on the outer tube, and the inner tube or tubes extend outward from the user, with the tool mounted on the narrowest/inner tube of the telepole. Such configurations are useful/practical when using a telepole to reach upward or overhead as the highest portions of the telepole are also the lightest. However, swimming pool cleaning generally involves a lateral reach (for above-ground pools) or downward reach (for in-ground pools) which is easier to perform with the heavier part of the telepole extending away from the user. Furthermore, telepoles such as those used for window washing or painting would be especially impractical as the locking devices would be almost constantly under water, hindering the ease and ready adjustment of the telepole's length needed to clean a swimming pool.

Also, the locking devices of telepoles used in other applications are unsuitable for swimming pool cleaning applications. For instance, external locking devices, such as those found on telepoles used for window washing, painting, or marine applications, tend to make pool cleaning difficult as they can easily catch on the edge of a pool or other objects when the telepole is being used, among other things. For example, the Mr. Long Arm Pole (shown in U.S. Pat. No. 5,220,707) has an external locking device with a button that activates a detent mechanism to engage and release the inner tube of the telepole, but is not suitable in swimming pool applications for a number of reasons. Among other things, it is configured the opposite of what is desirable/useful for cleaning swimming pools (i.e., the lighter parts of the pole extending away from the user). Further, the Mr. Long Arm pole is sealed at both ends by a grip on the outer tube end and a threaded adapter on the inner tube end, and therefore is unable to accommodate the commonly-used V-clips of most swimming pool cleaning tools. Moreover, its inner tube is unsealed on the end opposite the threaded adapter (the end that is inserted into the outer tube) and where a series of holes that receive the detent mechanism of the locking device are located along the inner pole's length. These openings in the inner tube would allow water to enter the pole when it is placed in a pool, etc. and make the telepole awkward and cumbersome to maneuver and control during use. Additionally, since the grip is mounted on the end of the outer pole, the detent mechanism would almost always be underwater during use, and adjusting the pole's length would inconveniently require a user to withdraw some or all of the pole from the pool.

Other prior art telepoles have lever-activated compression fittings. Devices having a lever fitting are suitable for certain applications in which a user does not need to adjust his grip/move his hand position from the wider tube to the

6

narrower tube. However, swimming pool cleaning commonly requires a user to repeatedly pass his or her hands back and forth over the locking device (to/from one tube to the other) during cleaning in order to be able to adjust his/her reach, get desired leverage on the tool, etc. Therefore, bulky and/or angular levers that are commonly used on telepoles for other applications may obstruct a user's hand from easily passing back and forth over the lever and thus reduce a user's ability to effectively clean a swimming pool. Furthermore, bumping a lever may cause pain or even injury to a user, especially if his or her hands have been wet for some time or exposed to pool chemicals. Even further, bumping the lever with one's hands, an object, or even against the pool deck may cause the lever to release unintentionally.

Still other problems occur with prior art as the inner tube may easily be overextended, especially among telepoles used for cleaning swimming pools. When overextension occurs, the inner tube can slide completely out of and separate from the outer tube. As a result, the outer tube, along with the attached cleaning tool, can sink to the bottom of a pool and be difficult to retrieve. Reassembling the telepole can be difficult and especially inconvenient if the inner tube has a cam locking device mounted on it since reassembly of the telepole requires that the cam's shoe, the inside tube and outside tube all must be aligned with each other for them to slide back together.

Additional problems arise with grips that fail to remain tightly attached to the end of the inside tube. While grips are generally designed to fit very tightly, they still can be knocked off the end of the inside tube if that tube slides too far or too quickly into the outside tube. When this happens, the inside tube may pass completely out the other end of the outside tube, or at least past the compression ring (on tubes with compression locks). Consequently, a user must reassemble nearly all of the telepole in order to use it again.

OBJECTS AND ADVANTAGES OF THE INVENTION

It is, therefore, an object of my invention to provide an improved telepole device having attachment means for attaching swimming pool cleaning tools. The improved telepole device preferably includes an inner tube which freely slides within an outer tube, and a locking device to temporarily secure said inner tube in a desired position within the outer tube. In a preferred embodiment, both the inner and outer tubes are fabricated from aluminum or a similar material that is both lightweight and durable, and most of the inner tube's length can slide into and extend out from one end of the outer tube. A preferred lightweight design may be at least partially hollow along the length of the tube(s), and durability may be provided by inner/reinforcement wall(s) that extend across the hollow portion(s) of one or both of the tubes. Preferably, one end of the inner tube has a grip mounted thereon which makes that end easy to grasp/grip and also prevents the inner tube from sliding entirely within the outer tube. On the end of the outer tube through which the inner tube slides/extends is a collar element attached thereto and comprised of a locking device having a detent mechanism for "locking" the inner tube in place within the outer tube. Additionally, the inner tube preferably has a distinct profile that matches the opening of the collar element through which it extends. Preferably, the collar's opening and the profile of the inner tube have one or more sides that, due to their relative position with respect to each other, can prevent the inner tube from rotating within the collar. Further, the inner tube preferably has a series of

US 11,141,852 B2

7

holes along its length which are positioned to receive a pin element of the detent mechanism. The pin element is preferably attached to a spring element and held in place by a housing which is formed into the collar. In its normal "resting" position, the spring pushes the pin towards the inner tube such that, when the pin is aligned with one of the holes in the inner tube, the pin sits in the hole and "locks" the inner tube in position so that it cannot slide/rotate within the outer tube or collar. Also preferably, within an upper portion of the housing above the pin is a button that, when depressed, forces the spring to reverse itself from its normal "resting" position and consequently lifts/releases the pin from its normal position in the housing so that the inner tube may be moved to a new position. Further, the end of the outer tube opposite the collar preferably has attachment holes configured to receive attachable and detachable swimming pool cleaning tools, and an additional set of holes that allow water to drain from the outer tube while a tool is attached.

A further object of my invention is to provide a telepole for cleaning swimming pools, with a detent mechanism as described above, and characteristics that prevent water from entering the inner tube during use so as to preserve the inner tube's buoyancy. In a preferred embodiment, a barrier is formed or otherwise provided inside the inner tube along its length and adjacent to the length-selection holes, to prevent water that may flow through those holes from entering the bulk of the inside portion of the inner tube. In addition, the telepole's buoyancy preferably is further maintained by a plug which is preferably mounted into or otherwise on the end of the inner tube that is opposite the gripping portion. The plug prevents water from entering the inner tube through its end. The end of the outer tube opposite the collar preferably has holes configured to receive attachable and detachable swimming pool cleaning tools.

Another object of my invention is to provide a telepole for cleaning swimming pools, with a compression device to "lock"/temporarily secure the inner tube within the outer tube at a desired position along the inner tube's length. The compression device and the inner tube preferably have corresponding detent-like contact surfaces that engage and disengage each other when the compression device is tightened and loosened, respectively, and enable a user to change the length of the telepole as needed.

Still another object of my invention is to provide a stronger telepole for cleaning swimming pools, including an inner tube that slides within an outer tube and can be "locked"/secured in various places along the length of the inner tube. The inner tube has one or more additional inner/reinforcement walls along its length to add strength and to help keep the inner tube true and round.

Yet another object of my invention is to create a telepole for cleaning swimming pools, including an outer tube having a collar on one end, the collar having a central opening through which an inner tube extends. The collar's opening and the profile of the inner tube have one or more sides keyed to each other such that, due to their shapes, the inner tube cannot rotate within the collar. The collar preferably is configured to include a compression device to lock the inner tube at any given area along its length.

Still another object of my invention is to provide a telepole assembly and related methods for cleaning swimming pools, including an inner tube and an outer tube, and further including a lever-action compression device that is easy on a user's hands. In one of many potential embodiments, the lever is installed in a housing formed within a collar that is mounted on the end of an outer pole. The

8

housing is configured to prevent the lever's edges or corners from protruding in such a way that they might be accidentally bumped by a user's hands or some other object that may disengage the lever. The inner tube preferably has a distinct profile that matches and/or is keyed to the opening of the collar, the compression device, or both, through which it extends. Among various embodiments, the collar's opening, the compression device, or both, and the profile of the inner tube can have one or more flat sides that, due to their shapes, prevent the inner tube from rotating within the collar. The inner tube preferably has a plug in its end furthest from the grip, said plug preserving buoyancy by preventing water from entering the inner tube.

Yet another object of my invention is to provide a telepole for cleaning swimming pools, including an inner tube and an outer tube, in which the outer tube is made with a profile that is not perfectly round, and the inner tube has a locking device mounted into it. The locking device is activated when a user twists the inner tube and causes the locking device to wedge itself against the uneven inner walls of the outer tube; said locking device being deactivated by a twist in the reverse direction. Other of the many embodiments of the invention would include reversing the parts just described, so that the inner tube is not perfectly round so that twisting of the inner tube with respect to the outer tube will result in a temporary fixed engagement of the two tubes with each other.

Still another of the many embodiments of the invention would include an inside tube and an outside tube having profiles similar to each other, with neither profile being perfectly round. The inside tube further has one or more additional/inner reinforcement walls along its length to add strength and help the inside tube retain its shape and remain true and straight. The inside tube slides within the outside tube and can be extended out of the outside tube to give the telepole additional length. A user can "lock" the telepole at an overall desired length by rotating the inside tube within the outside tube until the sides of both tubes, being slightly out of round, wedge themselves against each other. Similarly, a user can "unlock" the telepole by rotating the inside tube in the reverse direction, and subsequently readjust the overall length of the telepole. A plug may further be added to the inside tube to prevent it from filling with water during use in a pool or similar water feature.

#### BRIEF DESCRIPTION OF THE DRAWINGS

FIG. 1 is a plan view of a preferred embodiment of a telepole constructed in accordance with the teachings of the invention;

FIGS. 2a and 2b are sectional views taken along Line 2a/2b-2a/2b of FIG. 1, showing an exploded view of the detent mechanism of the preferred embodiment;

FIG. 2c is an alternative embodiment of the detent mechanism shown in FIGS. 2a and 2b;

FIG. 3 is a sectional view taken along Line 3-3 of FIG. 2a; FIG. 3a is a profile view of the inner tube of the preferred embodiment;

FIG. 3b is a dimensional view of a portion of the section taken along Line 2a/2b-2a/2b of FIG. 1;

FIG. 3c is an alternative embodiment of FIG. 3a;

FIG. 3d is a dimensional view of FIG. 3c;

FIG. 4a is an alternative embodiment of FIG. 3a;

FIG. 4b is an alternative embodiment of FIG. 3;

FIG. 5a is a dimensional view of a saddle bushing used in the preferred embodiment;



9

10

FIG. 5*b* is a sectional view taken along Line 5*b*-5*b* of FIG. 2*a*;

FIG. 6*a* is an alternative embodiment of FIG. 3*a*;

FIG. 6*b* is an alternative embodiment of FIG. 3*b*;

FIG. 7 is a partial view of an alternative embodiment of FIG. 1;

FIG. 8 is a sectional view taken along Line 8-8 of FIG. 7;

FIG. 9 is a profile view of the inner tube of FIG. 8;

FIG. 10 is an alternative embodiment of FIG. 7;

FIG. 11 is an alternative embodiment of FIG. 7;

FIG. 11*a* is a sectional view taken along Line 11*a*-11*a* of FIG. 11;

FIG. 12 is an alternative embodiment of FIG. 11;

FIG. 12*a* is a sectional view taken along Line 12*a*-12*a* of FIG. 12;

FIG. 12*b* is an alternative embodiment of FIG. 12;

FIG. 12*c* is a sectional view taken along line 12*c*/12*d*-12*c*/12*d* of FIG. 12*b*;

FIG. 12*d* is a sectional view taken along line 12*c*/12*d*-12*c*/12*d* of FIG. 12*b*;

FIGS. 13*a* and 13*b* are front views of an inner tube's internal locking device;

FIG. 13*c* is a front view of FIGS. 13*a* and 13*b*, within an outer/lower tube;

FIG. 14 is an alternative view of FIG. 12*a*;

FIG. 15*a* is a profile view of a tubular handle having an inner/reinforcement wall, in accordance with an embodiment of the present invention;

FIG. 15*b* is an alternative embodiment of FIG. 15*a*;

FIG. 16*a* is an elevation view of a tubular handle having inner/reinforcement walls attached to a tool, in accordance with an embodiment of the present invention;

FIG. 16*b* is similar to FIG. 16*a*, having a gripping portion on the end of the tubular handle;

FIG. 17 shows a tubular handle similar to that shown in FIG. 16*b* being detached from a tool;

FIG. 18*a* is an elevation view showing a quick-release device being used with a tool and handle in accordance with an embodiment of the present invention;

FIG. 18*b* is similar to FIG. 18*a*, wherein the tubular handle is attached to another similar tubular handle to increase the overall length of the handle configuration of the device;

FIG. 18*c* shows the attachment of two similar tubular handles together;

FIG. 18*d* is similar to FIG. 18*b*, wherein the similar tubular handles are joined together using a coupling device;

FIG. 18*e* shows the attachment of two similar tubular handles together using a coupling device in accordance with an embodiment of the present invention;

FIG. 19*a* shows a coupling device in accordance with an embodiment of the present invention, wherein the end(s) of the coupling device are female and receive a male end of a tubular handle;

FIG. 19*b* shows a coupling device in accordance with another embodiment of the present invention, wherein the end(s) of the coupling device are male and are received into a female end of a tubular handle;

FIG. 19*c* shows a coupling device in accordance with yet another embodiment of the present invention, wherein the coupling device has both a male and female end which matingly engage with a female and male end of a tubular handle, respectively;

FIG. 20 shows a tubular handle in accordance with an embodiment of the present invention, wherein the tubular handle has both a male and female end for connecting to a similar tubular handle and/or coupling device;

FIG. 21 shows a tubular handle attached to a tool in accordance with an embodiment of the present invention, wherein the handle is at least partially hollow, and a reinforcing device is inserted into the hollow portion of the handle to provide reinforcement for the handle

FIG. 22 is a profile view of a tubular handle having an elliptical profile and having inner/reinforcement walls, in accordance with an embodiment of the present invention;

FIGS. 23*a* and 23*b* show buoyancy plug means for maintaining a tube's buoyancy, in accordance with an embodiment of the present invention;

FIGS. 24*a* and 24*b* show plug means being adapted to also function as interior locking devices, in accordance with an embodiment of the present invention;

FIG. 24*c* shows a plug means similar to the one shown in FIGS. 24*a* and 24*b*, wherein the plug is operatively assembled within a telepole device according to an embodiment of the invention;

FIG. 25 shows a telepole end portion having additional holes to enable tools with various V-clip positions to be oriented on the telepole with respect to the position of the lever/button of the detent means.

DETAILED DESCRIPTION

Embodiments of the present invention will now be described with references to the accompanying figures, wherein like reference numerals refer to like elements throughout. The terminology used in the description presented herein is not intended to be interpreted in any limited or restrictive manner, simply because it is being utilized in conjunction with a detailed description of certain embodiments of the invention. Furthermore, various embodiments of the invention (whether or not specifically described herein) may include novel features, no single one of which is solely responsible for its desirable attributes or which is essential to practicing the invention herein described.

Although the examples of the many various methods of the invention are described herein with steps occurring in a certain order, the specific order of the steps, or any continuation or interruption between steps, is not necessarily intended to be required for any given method of practicing the invention.

Persons of ordinary skill in the art will understand that the apparatus of the invention and various of its many methods can be practiced using any of a wide variety of suitable processes and materials. By way of example and not by way of limitation, certain embodiments of the apparatus can be manufactured via processes using one or more steps of routing, drilling, turning, injection molding, extruding, thermo-forming, casting, and many other existing and new processes that may come into being. Materials are not limited in any way and could extend from metals to plastics, to resins of all types. A preferred material is lightweight, non-corrosive and will hold up to the exposure anticipated in its eventual usage (including by way of example, chlorinic water, salt water, marine environments, UV exposure, etc.). A preferred method of manufacture is by injection molding and extruding various components of the embodiments, and by machining others and/or buying them from commercially-available sources.

Referring now to the drawings, and particularly to FIGS. 1, 2*a*, 2*b*, 3*b*, 5*a*, and 5*b*, a preferred embodiment of a telepole device 1 used for cleaning swimming pools is shown, including an outer/lower tube 2 having a collar element 3 with a detent locking device 4 mounted thereon, and an inner/upper tube 5 that slides through an opening in

## US 11,141,852 B2

## 11

the collar element and within the outer tube. Preferably, the inner/upper tube has a profile with a smaller circumference than that of the opening of the collar element and the outer/lower tube so that it may readily slide within/through those elements in order to provide a telepole device having an adjustable length. Further, the inner/upper tube has a gripping portion 8 that may be attached with rivets, screws or other temporary or (semi-)permanent attachment devices. The gripping portion provides an area for a user to grip/grasp the telepole device and also prevents the inner tube from sliding entirely within the outer tube as the circumference of the gripping portion is larger than that of the collar element and/or outer/lower tube. Further, attachment devices (rivets, screws, or the like) can prevent the gripping portion from being "bumped" off the end of the tube when the inner tube slides into the outer tube, and they also make removing and/or replacing a worn handle possible.

Preferably, the outer/lower tube has a series of openings/holes 2a for receiving attachment means of cleaning tools, and has at least one drain hole 2b for allowing water trapped in the outer/lower tube to drain out. As will be further described herein, some of the many alternative embodiments of the invention can be practiced without all of these elements. Moreover, persons of ordinary skill in the art will understand that the elements described herein may even be provided in other embodiments in a wide variety of other forms depending on the desired use/application of the device.

As indicated, the present invention preferably includes means to adjust the length of the pole within the assembly. Persons of ordinary skill in the art will understand that this can be accomplished in a wide variety of ways, using various apparatus and methods. In a preferred embodiment of the present invention, the inner/upper tube has a series of openings/holes 6 along its length that are configured to receive a detent pin element 7 located in a housing 10 of the collar element in order to "lock"/temporarily secure the inner/upper tube in a desired position within the outer/lower tube. The detent pin element is affixed to a spring element 9 that, when in its normal "relaxed" position, allows the pin element to sit/rest simultaneously in a hole 10a through the housing of the collar element and one of the holes of the series 6 in the inner tube, thus locking the inner/upper tube into a desired position within the outer/lower tube. In addition, a button element 11 is mounted within the housing above the detent pin and is held in place by tab elements 12. When the button element is depressed by a user, the spring is pressed against an uneven surface 13 in the housing and forced into an "unrelaxed" position which in turn causes the pin element to be lifted out of the inner tube's hole 6, thus releasing the inner tube so that it can be moved into a new position within the outer tube. Releasing the button allows the spring to revert to its normal, relaxed position and enables the detent pin to reenter a hole 6 in the inner tube so that the inner tube may be secured in another desired position within the outer tube.

Further in a preferred embodiment, a saddle bushing 5a is provided between the outer wall 15 of the of the inner tube and the inner wall 16 of the outer tube. The saddle bushing element has a post element 14 that fits into a designated hole 6a for receiving the post element in the inner tube in order to guide the inner tube into proper alignment with the outer tube (i.e., so that the detent pins may be readily aligned with the detent holes) and to prevent the inner tube from sliding past the housing and separating from the outer tube. Further, a plug 21 at the end of the inner tube opposite the end with

## 12

the gripping element 8 preferably prevents water from entering through the inner tube's end.

Telepoles which are used in swimming pool (or similar) cleaning applications are repeatedly submerged in water of varying depths. Accordingly, a telepole capable of reaching below the water's surface (at times a significant amount below) is desirable, especially when cleaning deep areas of a pool, during long reaches, or both. It is a well known issue that water may easily enter the outer tubes of prior art extendible poles, through an attachment hole or other opening, and it may likewise enter the inner tube of the pole assembly. It is very undesirable, however, for water to enter the inner tube because, for example, it adds a significant amount of weight to the telepole device making it more difficult to maneuver the pole/assembly and taking longer to drain the device.

Accordingly, in a preferred embodiment of the present invention, the inner tube is configured such that water is prevented/stopped from entering some (and preferably most or even all) of the hollow portion of the inner tube. Persons of ordinary skill in the art will appreciate that there are numerous potential inner tube configurations which may provide a water tight seal to the telepole device, and that depending on the intended use of the device, any of these potential configurations (or combinations of them) may be desirable for use with the present invention. Moreover, any existing non-water tight inner tube of an existing device may be retrofitted with an inner tube that is configured to prevent water from leaking in.

FIG. 3a shows an example of a preferred inner tube which is configured to provide a watertight seal. The inner tube has a barrier 17 which prevents water from entering the inner tube through the series of detent holes 6 along the length of the inner tube. Preferably, the barrier runs the length 17a of the inner tube, and is configured to allow the detent pin 7 enough space to sit within the hole 10a of the housing 10 and a detent hole 6 in the inner tube when the spring 9 is in its normal, relaxed position. In such embodiments, almost the entire interior volume of the inner tube is watertight; the only portion "open" to water is the small sliver of space between the tube outer wall and the barrier 17, into which the pin protrudes when engaged. Although a watertight telepole device is desirable for many reasons in pool/water cleaning applications, persons of ordinary skill in the art will appreciate that the numerous benefits provided by this invention may still be realized even in non-watertight embodiments.

Further in a preferred embodiment, the inner tube has a distinct profile/shape that corresponds or is keyed to the profile/shape of the opening 10b of the collar element through which it extends. Among other things, this keyed relationship can prevent the undesirable rotation of the inner/upper tube within the collar element and outer/lower tube, and thereby allow the user to have more certain control over the assembly during its use in cleaning or other activity. In this preferred embodiment, the collar's opening and the profile of the inner tube are similarly out-of-round having one or more corresponding "sides" 18a that prevent the inner tube from rotating within the collar. This ensures that the pin 7 will always be aligned with the series of detent holes 6 along the length of the inner tube, and it enables a user to maneuver attached tools more effectively during cleaning.

In a preferred embodiment of the present invention, an inner/upper tube with a profile that includes one or more additional inner walls across its diameter is provided in order to give the inner/upper tube added strength along its

US 11,141,852 B2

13

length. This improved inner/upper tube with additional inner strengthening walls may be used with existing telepoles (for swimming pools or other uses) in a retrofit embodiment. In this embodiment, the existing inner/upper tube may be replaced/retrofitted with an improved inner/upper tube with additional inner strengthening walls or means. In this embodiment, the existing and improved inner/upper tubes have the same outer profiles along their lengths such that they both readily slide through the collar and outer/lower tube, and can easily be replaced with one another.

More broadly, persons of ordinary skill in the art will understand that the various components of certain embodiments of the invention can be provided in a modular and interchangeable form, facilitating economic manufacture/assembly/distribution of the devices, easy replacement of worn or damaged parts, exchange of longer pole/tube elements for shorter ones (and vice versa), and other benefits.

Persons of ordinary skill in the art will appreciate that a variety of inner tube profiles/shapes may be provided in accordance with the present invention. For example, among the many benefits provided by varying profiles/shapes/configurations, the inner tube(s) of the present invention may be configured to reduce bending of the inner tube, prevent water from entering the inner tube through the detent holes, keep the inner tube from rotating within the outer tube, and/or facilitate a plug with a locking device having a shape that corresponds to a tube's profile.

In a preferred embodiment of the present invention, additional wall(s) 17b may be provided along the length 17c of the inner tube to increase its strength/resistance to bending, denting, etc. Persons of ordinary skill in the art will appreciate that those additional wall(s) may be configured in many possible ways while still providing additional strength along the length of the tube. For example, FIGS. 15a and 15b show two possible configurations of inner/reinforcement walls provided within a tubular handle. In FIG. 15a, a single reinforcement wall extends along a hollow portion of the inner tube from one side of the tube to another. In FIG. 15b, additional walls are provided which cross at least a portion of the tube's inner profile and intersect with each other at approximately the center of the inner portion of the tube. Persons of ordinary skill will understand that these are just examples of some of the possible configurations of reinforcement wall(s) within an inner tube, and that other possible configurations and numbers of walls which may be provided are virtually unlimited. As an example, FIG. 22 shows inner/reinforcement walls provided within a telepole having an elliptical profile. In such an embodiment, both the outer/lower tube and inner/upper tube of the telepole/tube have elliptical profiles, and inner/reinforcement walls are provided along the length of the inner tube.

In addition to or within another embodiment, a thickened wall portion 19 along the length of an inner tube may be provided with detent holes 6 drilled partially into that thickened portion to accommodate detent pins, and the remaining portion 20 providing a barrier that prevents water from entering the inner tube.

In embodiments having thickened wall portions and/or reinforcement walls, buoyancy plug(s) may be provided within an inner/upper tube to maintain and/or increase the buoyancy of the tube. FIGS. 23a and 23b show possible buoyancy plug embodiments, wherein the plugs are configured to accommodate reinforcement wall(s) and/or thickened wall portion(s) within an inner/upper tube. In addition and as shown in FIGS. 24a-c, such plugs can be further adapted to function as interior locking devices having spreaders or an eccentric cam. In such embodiments, a cam

14

assembly on the plug is configured as a "stop" to keep the inner/upper tube assembled within the outer/lower tube. As shown in the figures, a portion of the plug and/or cam assembly is wider than the opening on the compression nut to prevent the inner/upper tube from sliding out of the outer/lower tube when the telepole is fully extended. In a telepole device that does not have a compression locking device, a ridge on the collar of the device (similar to the compression nut shown in the drawings) may function to prevent the inner and outer tubes from separating.

In another alternative embodiment of the present invention, the inner tube may be provided with notches 22 about its circumference or other/similar sides that correspond to protrusions/tabs in the collar element in order to prevent the inner tube from excessively or undesirably rotating within the outer tube during use. Alternatively or concurrently, further barriers/parts such as a sleeve element 23 or cup element 24 may be permanently or temporarily provided in key areas to provide a water tight seal to the inner tube.

Furthermore in an alternative embodiment of the present invention, an outer tube having a profile that is not perfectly round may be provided along with an inner tube having a locking device mounted thereon or integral therewith. In this embodiment, the locking device is activated when a user twists the inner tube and causes the locking device to wedge itself against the uneven inner walls of the outer tube. The locking device is deactivated by a twist in the reverse direction.

Persons of ordinary skill in the art will appreciate that the detent mechanism of the present invention has many potential embodiments, all of which provide the benefits realized by the present invention. Referring now to FIGS. 7, 8, 9, 10, 11, and 11a, in one potential embodiment, the inner tube 5a may have a row of teeth 25a or other detent components along some or all of its length, a collar with a housing 10 formed into it, and a detent mechanism 4 including a device such as a rocking lever 26 with corresponding teeth 25b or some other element corresponding to the inner tube's detent component. Yet another preferred way of practicing the detent mechanism of the present invention is a spring-loaded lever detent means. As shown in FIG. 2c, unlike the rocking lever detent means of FIG. 8, the spring-loaded lever mechanism has a detent pin that fits into holes along the inner tube.

Persons of ordinary skill in the art will also appreciate that the detent components of the inner tube may be configured, formed and/or attached to the inner tube in many ways. For example, a detent component 25a may be provided on an external portion of an inner tube 5a having a round profile. The external component may be integrally formed with the inner tube or permanently or temporarily attached to the inner tube during assembly. This external component may provide "sides" on the inner tube that correspond to indentations/protrusions/tabs on the collar in order to prevent unwanted/excessive rotation of the inner tube within the outer tube.

With the addition of a lever/button detent means, a "face" is created on the outside of the telepole (rather than the telepole simply being round with no identifiable sides/front/back). Therefore, additional attachment holes are needed to accommodate tools such as brushes having V-Clips which are mounted to the telepole in a horizontal position (with respect to the direction the tool moves when it is used to clean a pool, for example). Other tools such as leaf nets have V-Clips mounted in a vertical position in relation to the way the net moves through the water. As shown in FIG. 25, adding a second set of attachment holes (90 degrees away from the first set), the lever or button of the detent means can

## US 11,141,852 B2

15

be oriented to the tool according to the preference of the user. The addition of such holes may also reduce wear and tear on the end of a telepole. Since cleaning tools are almost constantly exposed to pressure during use, a plurality of attachment holes may distribute that pressure to more than one area around the telepole's end. Thus, a second set of such attachment holes may be added to telepoles that have no lever/button detent means or "face" and are round with no identifiable sides/front/back.

In an alternative embodiment, the inner tube may be formed with inclusions 5*b*, ribs or other detent components which correspond to complementary detent elements provided in a detent mechanism located adjacent to or within the outer pole's collar element, such as a rocking lever 26 or an end-hinged lever 27. In addition, a compression device such as the end-hinged lever shown in FIG. 11*a* or threaded compression ring 29 shown in FIG. 12 may further be used with a collar element 3 or some other compression device element. For example, a compression gasket 30 having an opening that corresponds to the profile of an inner tube 5*c* may be provided. In this embodiment, the gasket opening and corresponding profile of the inner tube are configured with one or more corresponding "sides" 18*a* that prevent the inner tube from rotating within the collar.

Additionally, FIGS. 12*b*, 12*c*, and 12*d* show a telepole device in accordance with the present invention having an outer tube including a collar element 3 comprised of a threaded portion 36 and a portion for receiving a compression gasket 34. Teeth, ridges, or other similar detent means 35 are formed into the compression gasket which matingly engage with inclusions, ribs or other similar detent elements 5*b* along the outer walls of the inner tube. Tightening the compression ring causes the teeth of the compression gasket to engage with the inner tube's detent elements and in turn prevents the inner tube from sliding within the outer tube. Conversely, loosening the compression ring disengages the teeth and detent elements, and permits a user to adjust the telepole's length by sliding the inner tube within the outer tube. In another embodiment, the compression gasket may be provided with ribs or similar detent means which correspond to detent features along the outer walls of the inner tube, and which hold the inner tube in place along the length of the outer tube but allow the inner tube to rotate within the outer tube. In yet another embodiment, the inner/upper tube and the compression gasket and/or collar's opening may each have one or more corresponding sides that prevent rotation of the inner tube within the outer tube.

Further, a plug or internal locking device 37 may be fitted into the end of the inner tube to further prevent the inner tube from slipping or rotating within the outer tube, and may even keep water from entering the inner tube. In certain embodiments, the internal locking device may include an off-center cam 38 or other spreading device 31 having moving parts 32 that can be wedged against the inner walls of the outer tube in order to lock the inner tube in a desired position along the length of the outer tube. Even further, the inner tube may have one or more sides that are keyed to correspond with one or more sides of the compression device and/or its components to facilitate "locking" the inner tube in place with respect to the outer tube and preventing any undesired or excessive rotation of the inner tube within the outer tube.

Moreover, a telepole with any suitable compression device for "locking" the inner tube in a given position within the outer tube may further include an outer tube which is configured to prevent the inner tube from rotating within the outer tube. In one potential embodiment, as shown in FIG. 14, an outer tube may be provided with an inward/interior-

16

facing protrusion 34 within its profile, and an inner tube may correspondingly have an indentation 35 within its profile. The indentation in the inner tube may be capable of receiving the outer tube's protrusion for the purpose of preventing the inner tube from rotating within the outer tube. Since such a configuration may make it difficult or impossible for the outer tube to receive standard cleaning tool attachment means, an adapter may be mounted on the outer tube's end to enable standard tools with V-clips to be attached to the present telepole device.

In some of the many alternative embodiments of the present invention, any levers and/or buttons, etc. may be partially or entirely recessed into a housing 10 that has sides 28 to protect the levers and/or buttons from being bumped by a user's hands or any other object or surface that may cause damage to or accidental release of the lever or detent mechanism.

In further alternative embodiments, a telepole for cleaning swimming pools in accordance with the present invention may include an outer tube whose profile is not uniformly round/circular along its length, and an inner tube having a cam or other similar spreading device 31. This configuration increases the ability of the inner tube to be "locked" in place within the outer tube. By twisting and rotating the inner tube within the outer tube, a user can misalign the cam or activate the spreading device so that the sides of its moving parts 32 engage themselves with the out-of-round inner walls 33 of the outer tube and lock the inner tube in a desired position. A reverse action disengages the cam or spreading device and unlocks the inner tube and permits readjustment of the telepole's length.

Persons of ordinary skill in the art will appreciate that the "locking" mechanisms described herein may be combined with other locking mechanisms described herein or others which are known in the art in order to provide a device that achieves the objects presented herein. On the other hand, any locking mechanism may stand alone to effectively achieve those objectives.

The present invention further provides means for attaching, detaching and re-attaching a variety of tools to the tubular handle of the present invention. As shown in FIGS. 16*a/b* and 17, a tubular handle of the type described herein having inner/reinforcement walls along its length may be attached to any type of tool, depending on the need of the user. If/when it is desired to remove/detach that tool from the tubular handle, the tool may be detached from the handle, as shown in FIG. 17.

In an embodiment of the present invention, that attachment means may be provided as a "quick-release" device for easy attachment and detachment of the tool and the tubular handle. As shown in FIGS. 18*a-c*, a quick-release device may be provided on the tool, handle, or both to enable ready attachment and detachment of the parts from each other. As shown in the drawings, a preferred quick-release device for use with the present invention is a spring-loaded button mechanism, however, persons of ordinary skill will appreciate that this is only an example of the many possible devices which may be used. For example, a quick-release device in accordance with the present invention may include a threaded end that can be twisted to either tighten or loosen the (tool) attachment, may be an interlocking device, and/or utilize V-clips, etc. The convenience provided by quick-releasing tools/handles is especially beneficial in applications of working with and finishing concrete wherein tools such as a bull float, trowel, rolling tamper, seamer, and various other tools or adapters are commonly used in conjunction with an extendable handle.

US 11,141,852 B2

17

Further, the benefits provided by a quick-release mechanism can be realized in attaching one or more tubular sections together for increasing the overall length of the handle. As shown in FIGS. 18*c-e*, a quick-releasing device/mechanism may be used to join one or more similar sections of tubular handle together. Persons of ordinary skill will appreciate that the quick-release mechanism may be provided on the tubular section(s) itself (FIG. 18*c*), on a coupling device (FIGS. 19*a-c*) for joining tubular sections, or both. Further, male and female mating ends may be provided in any configuration on the tubular sections and/or coupling devices in order to join similar sections of tubular handles together. Some examples include: a tubular handle in which one side is a male end configured to fit into the female end of another tubular handle; a tubular handle length that has only female ends; a tubular handle length that has only male ends; a tubular handle with at least one male end formed by 'necking down' the handle's male end or ends; and a tubular handle with at least one female end formed by 'expanding' the handle's female end or ends.

The apparatus and methods of my invention have been described with some particularity, but the specific designs, configurations, and steps disclosed are not to be taken as delimiting of the invention in that various modifications will at once make themselves apparent to those of ordinary skill in the art, all of which will not depart from the essence of the invention, and all such changes and modifications are intended to be encompassed within the appended claims.

The invention claimed is:

1. An elongated telescoping pole apparatus, including:
  - an elongated outer tube;
  - an elongated inner tube configured and sized to be slidably within said outer tube;
  - said inner and outer tubes keyed to prevent relative rotation of the tubes with respect to each other around a central longitudinal axis through the tubes;
  - said outer tube having first and second ends, said first end of said outer tube having a selectively actuatable detent configured to engage said inner tube at a selected position along the length of said inner tube, said second end of said outer tube having structure for removably attaching a tool;
  - said inner tube having first and second ends, said first end being received in said slidable relationship within said outer tube, said second end having a grip attached thereto, said selective sliding action of the tubes causing the respective distance between said grip on said inner tube and said actuatable detent on said first end of said outer tube to change;
  - the lengths of said outer and inner tubes when engaged with each other being sufficient to permit a user gripping said first end of said inner tube to manipulate the swimming pool cleaning tool at the second end of said outer tube against the bottom of a swimming pool while the user is standing on the side of the pool.
2. A telescoping pole apparatus, including:
  - an outer tube having first and second ends, said first end of the outer tube having a collar associated therewith, said collar containing a selectively actuatable detent, said second end of said outer tube having structure for removably attaching a tool;
  - an inner tube having first and second ends, said first end of said inner tube including a grip attached to the inner tube for a user to grasp and manipulate the apparatus, said second end of said inner tube being slidably received in the first end of the outer tube through an opening in said collar, said inner tube having a plurality

18

of detent holes positioned to be engaged with said actuatable detent, said inner tube being a single wall tube that is hollow along at least substantially its length between said first and second ends of said inner tube; and

said inner tube configured to slide within said outer tube to a selectable position relative to the outer tube, at which position said detent is configured to temporarily engage and hold said inner tube.

3. The apparatus of claim 2, further including a swimming pool cleaning tool attached to said second end of said outer tube using at least one V-clip that can be inserted into two holes positioned opposite each other near the end of said outside tube.

4. The apparatus of claim 2 or claim 3, wherein said structure for removably attaching a tool includes at least two pairs of holes, the holes in a given pair being positioned on opposite sides of said second end of said outer tube at the same position along a lengthwise axis of said outer tube.

5. The apparatus of claim 4, wherein at least one of said pairs of holes is at a different position along a lengthwise axis of said outer tube from another of said pairs.

6. The apparatus of claim 2, in which said outer and inner tubes are keyed to limit their rotation relative to each other around a central longitudinal axis running through the center of said tubes, said keyed relationship existing at all or substantially all of the positions in which said inner tube can be selectively positioned within said outer tube.

7. The apparatus of claim 2, in which said outer and inner tubes are keyed to limit their rotation relative to each other around a central longitudinal axis running through the center of said tubes, said keyed relationship existing between said collar and said inner tube.

8. The apparatus of claim 7, in which said inner tube has a cross-section that at least is keyed to an opening in said collar element through which said inner tube is slidably positioned, and the keyed relationship helps prevent or limit said inner tube from rotating within said collar around said longitudinal axis.

9. The apparatus of claim 7, in which said inner tube has a cross-section that at least is keyed to a compression gasket associated with said outer tube and through which said inner tube is slidably positioned, and the keyed relationship helps prevent or limit said inner tube from rotating within said gasket around said longitudinal axis.

10. The apparatus of claim 2, further including at least one more tube slidably engaged with at least one of said inner tube and/or said outer tube.

11. The apparatus of claim 2, wherein said grip has a larger diameter than the diameter of the inner tube.

12. The apparatus of claim 2, further including an adapter attached to said second end of said outer tube, said adapter having structure for using at least one V-clip to selectively connect pool cleaning tools to said adapter.

13. The apparatus of claim 2, said second end of said outer tube having a sidewall including:

at least two pairs of enclosed perforations through said sidewall and spaced radially from a longitudinal axis of said outer tube, a first perforation of a given pair being spaced radially on one side of the longitudinal axis and the other perforation of the pair being radially spaced on the other side of the longitudinal axis.

14. The apparatus of claim 13, in which the at least two pairs of perforations are spaced radially from the longitudinal axis at the same lengthwise location along a lengthwise axis of said outer tube.

US 11,141,852 B2

19

15. The apparatus of claim 13 or claim 14, in which the at least two pairs are positioned rotationally at 90 degrees from each other when measured rotationally around a lengthwise axis of said outer tube.

16. The apparatus of claim 2, wherein said detent holes provide a plurality of selected lengthwise positions for said actuatable detent.

17. The apparatus of claim 2, said inner tube having a thickened wall portion around at least a portion of said inner tube and extending along at least a portion of the length of said inner tube, said detent holes formed at least partially in said thickened portion.

18. The apparatus of claim 2, said detent including a spring-actuated lever lock.

19. The apparatus of claim 2, said inner and outer tubes formed from a relatively lightweight material such as aluminum.

20. A telescoping pole apparatus, including:

an outer tube having first and second ends, said first end of said outer tube having a collar associated therewith, said collar containing a selectively actuatable detent, said second end of said outer tube having structure for removably attaching a tool;

an inner tube having first and second ends, said first end of said inner tube including a grip attached to the inner tube for a user to grasp and manipulate the apparatus;

an intermediate tube slidably interposed between said inner and outer tubes, said intermediate tube having first and second ends, said first end of said intermediate tube slidably received in the first end of said outer tube through an opening in said collar, said intermediate tube having a plurality of detent holes positioned to be engaged with said actuatable detent of said outer tube's collar, said second end of said intermediate tube having a selectively actuatable detent;

said second end of said inner tube being slidably received in the second end of said intermediate tube through an opening in said intermediate tube's collar, said inner

20

tube having a plurality of detent holes positioned to be engaged with said actuatable detent of said intermediate tube's collar;

said intermediate tube configured to slide within said outer tube to a selectable position relative to said outer tube, at which position said detent of said outer tube is configured to temporarily engage and hold said intermediate tube; and

said inner tube configured to slide within said intermediate tube to a selectable position relative to said intermediate tube, at which position said detent of said intermediate tube is configured to temporarily engage and hold said inner tube.

21. An improved telepole device, comprising:

an outer tube element having first and second ends, said first end of the outer tube element having a collar element associated therewith, said collar element containing a detent means, said second end of the outer tube having attachment means for removably attaching a tool;

an inner tube element having first and second ends; said second end of said inner tube element being received in the first end of the outer tube through an opening in said collar element;

wherein said inner tube element is configured to readily slide within said outer tube element to a selected position along the length of the outer tube, and wherein said detent means is configured to temporarily lock the inner tube in that selected position within the outer tube.

22. The telepole of claim 21, wherein the tool is a swimming pool cleaning tool.

23. The telepole of claim 21, wherein the tool is a concrete finishing tool.

24. The telepole of claim 21, wherein said inner tube element has a cross-section that is generally round with at least one flat side, and said collar is keyed to engage said at least one flat side and thereby prevent rotation of said inner and outer tubes relative to each other.

\* \* \* \* \*

1  
2  
3  
4  
5  
6  
7  
8  
9  
10  
11  
12  
13  
14  
15  
16  
17  
18  
19  
20  
21  
22  
23  
24  
25  
26  
27  
28

**EXHIBIT B**

**Defendant James Conrad Gasped When he First Saw Plaintiff's '852 Patent  
Inventions**

Below is a true and correct Copy/Excerpt from U.S. Patent Office Records, Appl. Ser. No. 15/708,038 (from which the '852 Patent issued); Third Supplemental Amendment and Response filed November 14, 2019, at pages 1 and 124-129:

1  
2  
3  
4  
5  
6  
7  
8  
9  
10  
11  
12  
13  
14  
15  
16  
17  
18  
19  
20  
21  
22  
23  
24  
25  
26  
27  
28

File No. RESH-P3841.4

PATENT

IN THE UNITED STATES PATENT AND TRADEMARK OFFICE

In re Application of: Eric Resh

Serial No.: 15/708,038

Art Unit: 3723

Filed: September 18, 2017

Examiner: Scruggs, Robert

For: TELEPOLE APPARATUS AND RELATED METHODS

Commissioner for Patents  
P.O. Box 1450  
Alexandria, VA 22313-1450

**THIRD SUPPLEMENTAL AMENDMENT AND RESPONSE**

Sir:

Even before the current filings, Applicant has presented an overwhelming amount of strong evidence that Applicant's claimed inventions are not obvious (and therefore are patentable, as discussed here and in Applicant's previous filings). Applicant acknowledges that this document and the other materials that Applicant has filed are lengthy (although a substantial portion of them are graphics such as photos and screenshots, which should make them quicker and easier to review and consider).

**Certificate of Electronic Filing**

I hereby certify that this correspondence is being filed electronically via EFS with the U.S. Patent and Trademark Office, on the date below.

/J. Mark Holland/

November 14, 2019

J. Mark Holland, Reg. No. 32,416

DATE

1  
2  
3  
4  
5  
6  
7  
8  
9  
10  
11  
12  
13  
14  
15  
16  
17  
18  
19  
20  
21  
22  
23  
24  
25  
26  
27  
28



File No. RESH-P3841.4

Serial No. 15/708,038

...[W]e think that **the district court's finding that the developments embodied in the Conibear patent would have been obvious to one with ordinary skill in the pertinent art must be rejected. Although through the use of hindsight the Conibear patent may have appeared obvious,** we think the defendants failed to produce sufficient evidence to establish that Conibear's patent was an obvious development based upon the prior art. To invalidate a patent, the court, in evaluating the evidence, must be able to say that the differences between the prior art and the patented subject matter as a whole would have been obvious at the time of the invention to a person ordinarily skilled in the art. *Graham, supra*, 383 U.S. at 15, 86 S.Ct. 684. The heart of the defendants' case consisted of the testimony of one witness, admittedly completely unskilled in the trapping art, who concluded that the Conibear patent was obvious in the light of the prior art. This testimony, standing by itself, will not suffice to overcome the presumptive validity of the United States patent. This testimony stands in sharp contrast to other **evidence tending to show nonobviousness of the Conibear discovery, such as inventor Lehn's expression of surprise and excitement upon learning of this new trap...**

Thus, the *Woodstream* expert in the field testified that, upon seeing a picture of the relevant invention, he "**couldn't take [his] eyes off of that picture,** and felt that the picture of the invention "**almost knocked [him] off [his] feet.**"

As described below, that "expression of surprise" is very similar to the reaction that arguable "expert in the field"<sup>23</sup> Jim Conrad had to Applicant's

<sup>23</sup> Applicant does not concede that Jim Conrad is an "expert" for all purposes. As presently advised, however, Applicant understands that Mr. Conrad has worked at swimming pool pole company Skimlite since 1959, the year that Skimlite purportedly introduced the first telescoping swimming pool pole. Assuming those credentials accurate, it appears that his reactions to Applicant's inventions may have the same relevance to show nonobviousness, as did the "expert" in the *Woodstream* case. To be even more direct, Applicant is not waiving the right to challenge Mr. Conrad's "expert" qualifications in any future proceeding or filing.

1  
2  
3  
4  
5  
6  
7  
8  
9  
10  
11  
12  
13  
14  
15  
16  
17  
18  
19  
20  
21  
22  
23  
24  
25  
26  
27  
28

File No. RESH-P3841.4

Serial No. 15/708,038

inventions. One difference that may explain Mr. Conrad's even more physical reaction (as compared to the *Woodstream* expert) is that he was not just looking at a "picture" – he was holding Applicant's pole inventions in his hands.

1. Upon Seeing Applicant's DETENT-LOCKING Poles for the First Time, Competitor Skimlite/Jim Conrad GASPED and was SPEECHLESS!

In his current patent application, Applicant has presented evidence from a person who, like *Woodstream's* 75-year-old person, had spent his entire life in the relevant field. Specifically, Applicant has presented the reactions of Jim Conrad, who has spent his entire adult life manufacturing telescoping swimming pool poles with copier/competitor Skimlite. Mr. Conrad has worked with Skimlite since 1959, which would be 53 years of WORK there, at the time that Mr. Conrad saw Applicant's invention in 2012.

Applicant's evidence of Mr. Conrad's 2012 immediate reactions to Applicant's pole inventions, when Mr. Conrad **first** saw those inventions, shows that they were at least arguably similar to (and possibly even stronger than) the *Woodstream's* witness's "**expression of surprise and excitement upon learning of this new [invention].**" In some ways, Mr. Conrad's may have been even stronger and more telling than that of the *Woodstream* expert's reaction, because Mr. Conrad owned and/or was president of competing swimming pool pole-manufacturer Skimlite at the time he first saw Applicant's pole inventions.

125

HTTPS://D:\DOCS\LIVE\NET\065D5DAA52B06FC\CLIENTS\RESHP3841.4\_USPA\_POLE\_CONT\_3941\UPTO COMMUNICATIONS\2019\04\01\_0A\2019-05-30\_ID\_SUPP\_RESPONSE\DRAFTS\2019\_11\_14\_ID\_SUPP\_RESP\_2019\_04\_01\_0A\_FINAL.DOCX

File No. RESH-P3841.4

Serial No. 15/708,038

Mr. Conrad's **very immediate** and direct and observable physical reactions to seeing for the first time (while holding in his own hands) Applicant's pole inventions are as follows:

9. The first time that Jim Conrad apparently saw our new telescoping poles was about six years ago, at the Western Pool & Spa trade show in Long Beach, CA, March 15-17, 2012. I was working in our booth at that trade show when Jim walked by our booth, said "Hi," and then saw our [sample] pole lying on the table (button/detent side down). Jim asked something like, "Oh, what do you have here...?" **Jim actually gasped when he saw our detent-locking device on our pole.**

Eric Resh 2018 declaration, par. 9 (emphasis added).

In the Resh Second Declaration, Applicant has provided further details regarding Mr. Conrad's first sight of Applicant's detent-locking pole, to make even more clear that Mr. Conrad's extreme reactions were not caused by Applicant's new "pole" itself. Instead, Mr. Conrad, who had spent his life making and designing swimming pool poles, was shocked by seeing that Applicant had made a **"detent-locking" pole:**

**When [Mr. Conrad] saw that it had a detent-locking system (instead of a twist-lock), he immediately gasped. ... After seeing that lock, Jim Conrad was nearly speechless.**

Eric Resh Second declaration, pars. 10-14 (emphasis added).

If Applicant's pole inventions were "obvious," why would a person like Mr. Conrad (who spent his life making swimming pool poles) react as he did? Why would they gasp and be left speechless?

1  
2  
3  
4  
5  
6  
7  
8  
9  
10  
11  
12  
13  
14  
15  
16  
17  
18  
19  
20  
21  
22  
23  
24  
25  
26  
27  
28

File No. RESH-P3841.4

Serial No. 15/708,038

Applicant respectfully submits that, independently of anything else Applicant has presented, Mr. Conrad's reactions are strong and important evidence of an "AFTER" circumstance (for purposes of Judge Learned Hand's test) showing that Applicant's inventions are **not** obvious.

2. Mr. Conrad's Reactions are "PARTICULARLY TRUSTWORTHY" Evidence that Applicant's Inventions are Not Obvious

Again, Applicant respectfully submits that this extreme and immediate physical reaction by a competitor is especially trustworthy evidence about Applicant's pole invention NOT being obvious. In that regard, although this patent prosecution is not a lawsuit, Rule 803 of the Federal Rules of Evidence seems potentially very relevant to the weight that should be given to this particular "objective indicia evidence." That Rule indicates that the Examiner should give great weight to Mr. Conrad's foregoing reactions.

Rule 803 defines certain evidence as being so trustworthy that it is admissible even if it would otherwise be excluded as "hearsay." As discussed below, Mr. Conrad's reactions appear to qualify as this "especially trustworthy" evidence. Specifically, Rule 803 defines certain exceptional evidence that, although hearsay, is still admissible in Federal Court. Among those exceptions are two that seem to apply to Mr. Conrad's reactions: an "excited utterance" and/or "present sense impression." Those portions of Rule 803 read as follows:

127

HTTPS://D.DOCX.LIVE.NET/065D5D3A52B096FC/CLIENTS/RESHIP3841.4\_USPA\_POLE\_CONT\_3841\_IPTO\_COMMUNICATIONS/20190401\_0A/2019-04-30\_3D\_SUPPL\_RESPONSE/DRAFTS/2019\_11\_14\_3D\_SUPPL\_RESP\_2019\_04\_01\_0A\_FINAL.DOCX

File No. RESH-P3841.4

Serial No. 15/708,038

“The following are not excluded by the rule against hearsay, regardless of whether the declarant is available as a witness:

(1) *Present Sense Impression*. A statement describing or explaining an event or condition, made while or immediately after the declarant perceived it.

(2) *Excited Utterance*. A statement relating to a startling event or condition, made while the declarant was under the stress of excitement that it caused.”

Mr. Conrad’s immediate reaction to seeing Applicant’s pole seems to be a prime example of such especially **strong** evidence of the nonobviousness of Applicant’s pole inventions. One commentator<sup>24</sup> discussed the rationale for finding statements like Mr. Conrad’s to be **so trustworthy**:

The excited utterance exception [such as in Rule 803] provides that statements made under the influence of an exciting event while the speaker is still in a state of nervous excitement may be admitted for the truth of the matters they assert ... According to Wigmore, **a hearsay statement must meet the following criteria to qualify under this exception:** (1) there must be a “startling occasion.” (2) the out-of-court statement must be made before the declarant has had time to “fabricate.” and (3) the declarant’s out-of-court statement must relate to the circumstances of the startling event.

Wigmore explained **the policy of the exception** as follows:

This general principle is based on the experience that, **under certain external circumstances of physical shock, a stress of nervous excitement may be produced which stills the reflective faculties and removes their control, so that the utterance which then occurs is a spontaneous and sincere response to the actual sensations and perceptions already produced by the external shock.**

<sup>24</sup> Aviva Orenstein, *“MY GOD!”: A Feminist Critique of the Excited Utterance Exception to the Hearsay Rule*, 85 Cal. L. Rev. 159, 169-170 (1997).

File No. RESH-P3841.4

Serial No. 15/708.038

The witness' state of nervous tension was of utmost importance in Wigmore's analysis. According to Wigmore, **this "immediate and uncontrolled domination of the senses" lasts for a "brief period." "During this short time, neither thoughts of "self-interest" nor other "reasoned reflection" arise. Therefore, the utterance is "particularly trustworthy"** and may be admitted despite its hearsay character. Wigmore even hinted that **such evidence is superior to in-court testimony because of its spontaneity and closeness to the event.**

(footnotes omitted; emphasis added).

Based on all of the foregoing principles, Mr. Conrad's reaction should be considered by the Examiner to be yet another objective indicium of nonobviousness, and in fact a **very strong** indicium. Mr. Conrad experienced a "startling occasion" – he saw Applicant's detent-locking pole for the first time. His gasp and his speechlessness were immediate – before he had any opportunity to "fabricate" or fake some other reaction or comment. Finally, Mr. Conrad's reactions (gasp and speechlessness) were directly related to him turning over Applicant's pole in Mr. Conrad's hands, and seeing for the first time a detent-locking swimming pool pole.

Thus, Mr. Conrad's reactions were made before he could "fabricate." According to Professor Wigmore, his reactions are even "**superior** to in-court testimony" that Mr. Conrad might eventually provide on the issue.

**EXHIBIT C****Preliminary/Exemplary Claim Charts Showing Defendants' Infringement**

223. In the table below, Plaintiff's '852 Patent Claims 1, 2, 20, and 21 (the independent claims) from are shown in the left-hand column, and screenshots and other graphics and text relating to Defendants' corresponding infringing products are shown in the right-hand column. The table includes highlighting and text and other mark-up to show some of the correspondence between the claim elements on the left and the relevant parts of Defendants' infringing products on the right. As discussed above, Claims 1 and 21 are among those for which Defendants are liable for pre-issuance damages, and Claim 21 is the claim that Defendants have already admitted that they infringe.

224. The screenshots in the right-hand column are taken from videos and photographs posted on the Internet by Defendants and by third parties, including at the following locations:

- a. one of Defendants' own YouTube videos (at [https://www.youtube.com/watch?v=5ELd\\_3PpDI](https://www.youtube.com/watch?v=5ELd_3PpDI)) entitled "How to Use a Snaplite Pole." The relevant YouTube display indicates that Defendants posted the video on May 15, 2020. Defendants' video, and the excerpted screenshots below, show Defendant Barrett Conrad using one of Defendants' infringing poles (Defendants' model Snaplite 6016) [NOTE: Around the 0:39 time-stamp of Defendants' above video, Defendant Barrett Conrad admits that Defendants' Snaplite 6016 pole is "quickly becoming many people's favorite [pole]."];
- b. another of Defendants' own YouTube videos (at <https://www.youtube.com/watch?v=ldpzcFZJsW4>) entitled "Replace a Snaplite Button." The relevant YouTube display indicates that Defendants also posted this video on May 15, 2020. Defendants' video, and the excerpted screenshots below, show Defendant Barrett Conrad replacing the "button or lever" on one of Defendants' infringing poles.

**c.** a third party’s YouTube video (at <https://www.youtube.com/watch?v=0oRmQATEc5E>) entitled “The BRUTE Pole- Strongest Professional Grade Pool Pole! Plus the SKIMLITE 6000 SnapLite Series Poles”, with a posting date indicated as June 24, 2019; and

**d.** another YouTube video posted by that same third party (at <https://www.youtube.com/watch?v=u5hTKelagiE>), in which the third party narrator says (beginning at the 3:10 mark) that he “find[s] the [infringing Snaplite] buttons easier to use ... versus twisting and unlocking the [prior art Skimplite Dually model pole] sections.”

225. Below is the preliminary/exemplary table comparing certain of Plaintiff’s ‘852 Patent claims to examples of Defendants’ infringing products:

INDEPENDENT Claims of Plaintiff’s ‘852 Patent	Examples of Defendants’ Infringing Products (Model 6016 – 2 tubes; Model 6317 – 3 tubes)
1. An elongated telescoping pole apparatus, including:	 <p>[Two of Defendants’ poles are shown above, one each of Model 6016 and Model 6317. Defendants’ poles “telescope” within a range of lengths as shown below, and are elongated - the remaining parts of the pole extend out of the photograph to the right]. More complete photographic examples of Defendants’ full poles are shown below.</p>



1  
2  
3  
4  
5  
6  
7  
8  
9  
10  
11  
12  
13  
14  
15  
16  
17  
18  
19  
20  
21  
22  
23  
24  
25  
26  
27  
28

INDEPENDENT Claims of Plaintiff's '852 Patent	Examples of Defendants' Infringing Products (Model 6016 – 2 tubes; Model 6317 – 3 tubes)
<p>an elongated outer tube;</p> <p>an elongated inner tube configured and sized to be slidable within said outer tube;</p>	 <p>[Defendants' Model 6016 pole is shown above, in an extended (not collapsed) condition. The pole has an elongated outer tube (shown from the black housing in approximately the middle of the pole and extending into the water), and an elongated inner tube (shown as being gripped by the user, and extending generally from approximately the middle of the pole upwards to the red handle/grip). The inner tube is shown in the online videos as sliding within the outer tube (and therefore is configured and sized to be slidable)].</p>

1  
2  
3  
4  
5  
6  
7  
8  
9  
10  
11  
12  
13  
14  
15  
16  
17  
18  
19  
20  
21  
22  
23  
24  
25  
26  
27  
28

INDEPENDENT Claims of Plaintiff’s ‘852 Patent	Examples of Defendants’ Infringing Products (Model 6016 – 2 tubes; Model 6317 – 3 tubes)
<p>said inner and outer tubes keyed to prevent relative rotation of the tubes with respect to each other around a central longitudinal axis through the tubes;</p>	 <p>[The keyed relationship between the tubes of Defendants’ poles (to prevent relative rotation around the pole’s longitudinal central axis) is illustrated in the photos above. The top photo shows Defendants’ Model 6016 in a collapsed position (with the red grip close to the lever/button actuator). The middle photo shows the user pushing the lever/button with the user’s right thumb, and the inner tube (with the red grip) telescoped outwardly (away from the lever/button). The lower photo shows the upper end of the pole in an extended position. Collectively, the photos illustrate the keyed relationship that keeps the row of holes (on the inner tube) aligned with the lever/button (on the outer tube). In other words, the keyed relationship prevents the user from inadvertently twisting the tubes out of alignment, and consequently keeps the holes and the lever/button aligned]</p>

1  
2  
3  
4  
5  
6  
7  
8  
9  
10  
11  
12  
13  
14  
15  
16  
17  
18  
19  
20  
21  
22  
23  
24  
25  
26  
27  
28

<p><b>INDEPENDENT Claims of Plaintiff’s ‘852 Patent</b></p>	<p><b>Examples of Defendants’ Infringing Products (Model 6016 – 2 tubes; Model 6317 – 3 tubes)</b></p>
<p>said outer tube having first and second ends,</p>	<div data-bbox="938 283 1250 718" data-label="Image"> </div> <p data-bbox="711 724 1485 934">[The screenshot above is the lower right section of the screenshot at the beginning of this table, with a red arrow pointing to first end of the outer tube, and the black arrow pointing to the second end of the outer tube]</p>

1  
2  
3  
4  
5  
6  
7  
8  
9  
10  
11  
12  
13  
14  
15  
16  
17  
18  
19  
20  
21  
22  
23  
24  
25  
26  
27  
28



INDEPENDENT Claims of Plaintiff’s ‘852 Patent	Examples of Defendants’ Infringing Products (Model 6016 – 2 tubes; Model 6317 – 3 tubes)
<p>said first end of said outer tube having a selectively actuatable detent configured to engage said inner tube at a selected position along the length of said inner tube,</p>	<div data-bbox="938 275 1252 716" data-label="Image"> </div> <p>In that same picture, the red arrow points to a black housing on the first end of the outer tube. That black housing on that end of Defendants’ outer tube holds Defendants’ actuatable detent that engages Defendants’ inner tube at one of the holes a user selects along the length of Defendants’ inner tube.</p> <div data-bbox="737 1056 1455 1440" data-label="Image"> </div> <p>[Above, Defendant Barrett Conrad demonstrates how to assemble Defendants’ lever/button and spring into Defendants’ black collar/housing on the first end of Defendants’ outer tube, to operate Defendants’ actuatable detent] [SOURCE: <a href="https://www.youtube.com/watch?v=ldpzcFZJsW4">https://www.youtube.com/watch?v=ldpzcFZJsW4</a>; at 0:33 mark]</p>

1  
2  
3  
4  
5  
6  
7  
8  
9  
10  
11  
12  
13  
14  
15  
16  
17  
18  
19  
20  
21  
22  
23  
24  
25  
26  
27  
28

<p><b>INDEPENDENT Claims of Plaintiff’s ‘852 Patent</b></p>	<p><b>Examples of Defendants’ Infringing Products (Model 6016 – 2 tubes; Model 6317 – 3 tubes)</b></p>
	<p>Below is the assembled button/lever in the black housing on the outer tube’s first end, to operate Defendants’ detent.</p> 

1  
2  
3  
4  
5  
6  
7  
8  
9  
10  
11  
12  
13  
14  
15  
16  
17  
18  
19  
20  
21  
22  
23  
24  
25  
26  
27  
28

INDEPENDENT Claims of Plaintiff's '852 Patent	Examples of Defendants' Infringing Products (Model 6016 – 2 tubes; Model 6317 – 3 tubes)
<p>said second end of said outer tube having structure for removably attaching a tool;</p>	<div data-bbox="938 275 1252 716" data-label="Image"> </div> <p>Again in that same picture, the black arrow (in the pool water) indicates the second end of Defendants' outer tube, that includes holes for removably attaching a tool].</p> <div data-bbox="743 884 1450 1318" data-label="Image"> </div> <p>[Defendants' attachment holes on the second end of Defendants' outer tube are illustrated in the screenshot above. This screenshot shows the tube end without a tool engaged.]</p>

INDEPENDENT Claims of Plaintiff's '852 Patent	Examples of Defendants' Infringing Products (Model 6016 – 2 tubes; Model 6317 – 3 tubes)
	 <p data-bbox="711 743 1484 863">[The screenshot above shows a leaf rake tool (on the left) engaged with Defendants' attachment holes on the second end of Defendants' outer tube]</p>
<p data-bbox="235 905 691 1455">said inner tube having first and second ends, said first end being received in said slidable relationship within said outer tube, said second end having a grip attached thereto, said selective sliding action of the tubes causing the respective distance between said grip on said inner tube and said actuatable detent on said first end of said outer tube to change;</p>	 <p data-bbox="711 1537 1463 1875">In the same picture as at the beginning of this table, Defendants' product includes an inner tube with a first end (shown slidably inserted into the outer tube) and a second end positioned above the user's head. When the user slides the tubes with respect to each other, the grip (at the top) changes its distance from the detent (located at the black housing in the middle of the pole).</p>

1  
2  
3  
4  
5  
6  
7  
8  
9  
10  
11  
12  
13  
14  
15  
16  
17  
18  
19  
20  
21  
22  
23  
24  
25  
26  
27  
28

1  
2  
3  
4  
5  
6  
7  
8  
9  
10  
11  
12  
13  
14  
15  
16  
17  
18  
19  
20  
21  
22  
23  
24  
25  
26  
27  
28

INDEPENDENT Claims of Plaintiff’s ‘852 Patent	Examples of Defendants’ Infringing Products (Model 6016 – 2 tubes; Model 6317 – 3 tubes)
	 <p data-bbox="711 646 1484 1283">[Defendant Barrett Conrad expressly identifies the grip (the red piece above) on Defendants’ infringing Model 6016 poles] [SOURCE: <a href="https://www.youtube.com/watch?v=ldpzcFZJsW4">https://www.youtube.com/watch?v=ldpzcFZJsW4</a>; at 2:20 mark]. Defendants’ red grip is positioned on the second end of the inner tube, and the first end (in the direction of Mr. Conrad’s right hand, or to the left side of the screenshot above) of that same inner tube is received in a sliding relationship within the outer tube (the outer tube is in Mr. Conrad’s right hand, and has a black housing attached to it, that houses the button/lever detent). The sliding action allows the user to change the distance between the red grip and the button/lever detent in the black housing.</p>



1  
2  
3  
4  
5  
6  
7  
8  
9  
10  
11  
12  
13  
14  
15  
16  
17  
18  
19  
20  
21  
22  
23  
24  
25  
26  
27  
28

INDEPENDENT Claims of Plaintiff’s ‘852 Patent	Examples of Defendants’ Infringing Products (Model 6016 – 2 tubes; Model 6317 – 3 tubes)
	<p data-bbox="711 325 1469 493">In the photo below, the tubes are almost completely collapsed into each other, and the red grip is very close to the black detent housing (only one detent hole is showing on the inner tube).</p>  <p data-bbox="732 1081 1453 1155">Replace a Snaplite Button 04 views • May 15, 2020 <span style="float: right;">0 DISLIKE</span></p> <p data-bbox="711 1197 1469 1491">By way of contrast, in the photo below, the user (Defendant Barrett Conrad) has actuated the detent and slid the inner tube (and its red grip) to the right as viewed below. This shows the user’s selective sliding of the tubes with respect to each other changes the distance between the red grip and the black detent housing.</p> 

1  
2  
3  
4  
5  
6  
7  
8  
9  
10  
11  
12  
13  
14  
15  
16  
17  
18  
19  
20  
21  
22  
23  
24  
25  
26  
27  
28

INDEPENDENT Claims of Plaintiff’s ‘852 Patent	Examples of Defendants’ Infringing Products (Model 6016 – 2 tubes; Model 6317 – 3 tubes)
<p>the lengths of said outer and inner tubes when engaged with each other being sufficient to permit a user gripping said first end of said inner tube to manipulate the swimming pool cleaning tool at the second end of said outer tube against the bottom of a swimming pool while the user is standing on the side of the pool.</p>	 <p>6016 (8' to 16') TV</p> <p>INNER Tube</p> <p>OUTER Tube</p> <p>[The screenshot above is a repeat of the screenshot near the beginning of this table. Defendants’ Model 6016 pole is shown above, in an extended (not collapsed) condition. The user is gripping the inner tube and manipulating a swimming pool tool (a leaf rake shown at the bottom of the screenshot). That tool is attached to the second end of the outer tube, and the user is manipulating it against the bottom of the swimming pool in the screenshot, as the user stands on the side of the pool. The lengths of the outer and inner tubes are sufficient to permit the user to use the pole in this manner]</p>

1  
2  
3  
4  
5  
6  
7  
8  
9  
10  
11  
12  
13  
14  
15  
16  
17  
18  
19  
20  
21  
22  
23  
24  
25  
26  
27  
28

INDEPENDENT Claims of Plaintiff's '852 Patent	Examples of Defendants' Infringing Products (Model 6016 – 2 tubes; Model 6317 – 3 tubes)
<p>2. A telescoping pole apparatus, including:</p>	 <p>Defendants' poles are telescoping, as shown above and described further above.</p>
<p>an outer tube having first and second ends, said first end of the outer tube having a collar associated therewith, said collar containing a selectively actuatable detent, said second end of said outer tube having structure for removably attaching a tool;</p>	<p>[This is virtually a repeat of a corresponding Claim 1 limitation above, so Plaintiff incorporates by reference the corresponding photographs and information above.]</p>

1  
2  
3  
4  
5  
6  
7  
8  
9  
10  
11  
12  
13  
14  
15  
16  
17  
18  
19  
20  
21  
22  
23  
24  
25  
26  
27  
28

INDEPENDENT Claims of Plaintiff’s ‘852 Patent	Examples of Defendants’ Infringing Products (Model 6016 – 2 tubes; Model 6317 – 3 tubes)
<p>an inner tube having first and second ends, said first end of said inner tube including a grip attached to the inner tube for a user to grasp and manipulate the apparatus, said second end of said inner tube being slidably received in the first end of the outer tube through an opening in said collar, said inner tube having a plurality of detent holes positioned to be engaged with said actuatable detent,</p>	<p>[Most of this portion of the claim also is virtually a repeat of a corresponding Claim 1 limitation above, so Plaintiff incorporates by reference the corresponding photographs and information above.]</p> <p>Defendants’ infringing poles have a plurality of detent holes in the inner tube, to engage with the actuatable detent. Two of them are shown on the pole below held by Defendant Barrett Conrad, at the orange arrows in the screenshot below (from Defendants’ aforementioned May 15, 2020 YouTube video):</p>  <p>The screenshot shows a YouTube video player interface. At the top, there is a search bar and the YouTube logo. The video content shows a person wearing a grey t-shirt with the 'SKIMLITE' logo, holding a grey Snaplite pole. Two orange arrows point to specific features on the pole. The video player includes a progress bar at the bottom showing 0:35 / 0:47, and interaction buttons for like, dislike, share, and download. The video title is 'How to Use a Snaplite Pole' and it has 251 views as of May 15, 2020.</p>

1  
2  
3  
4  
5  
6  
7  
8  
9  
10  
11  
12  
13  
14  
15  
16  
17  
18  
19  
20  
21  
22  
23  
24  
25  
26  
27  
28

INDEPENDENT Claims of Plaintiff's '852 Patent	Examples of Defendants' Infringing Products (Model 6016 – 2 tubes; Model 6317 – 3 tubes)
<p>said inner tube being a single wall tube that is hollow along at least substantially its length between said first and second ends of said inner tube; and</p>	 <p>Defendants' inner tubes (such as shown above) are single wall tubes that are hollow along at least substantially their length between their first and second ends.</p>

1  
2  
3  
4  
5  
6  
7  
8  
9  
10  
11  
12  
13  
14  
15  
16  
17  
18  
19  
20  
21  
22  
23  
24  
25  
26  
27  
28

INDEPENDENT Claims of Plaintiff's '852 Patent	Examples of Defendants' Infringing Products (Model 6016 – 2 tubes; Model 6317 – 3 tubes)
<p>said inner tube configured to slide within said outer tube to a selectable position relative to the outer tube, at which position said detent is configured to temporarily engage and hold said inner tube.</p>	 <p>Defendants' inner tube is configured to slide within the outer tube to a selectable position relative to the outer tube, at which position the detent is configured to temporarily engage and hold the inner tube. In the photograph above, the user has slid the inner tube to a selected position, temporarily engaged the detent into one of the plurality of detent holes in the inner tube, and is using the pole (at that selected/engaged/held position) to clean the pool.</p>
<p>20. A telescoping pole apparatus, including:</p>	<p>Defendants' infringing poles are telescoping pole apparatus.</p>

**INDEPENDENT Claims of Plaintiff’s ‘852 Patent**

an outer tube having first and second ends, said first end of said outer tube having a collar associated therewith, said collar containing a selectively actuatable detent, said second end of said outer tube having structure for removably attaching a tool;

**Examples of Defendants’ Infringing Products (Model 6016 – 2 tubes; Model 6317 – 3 tubes)**

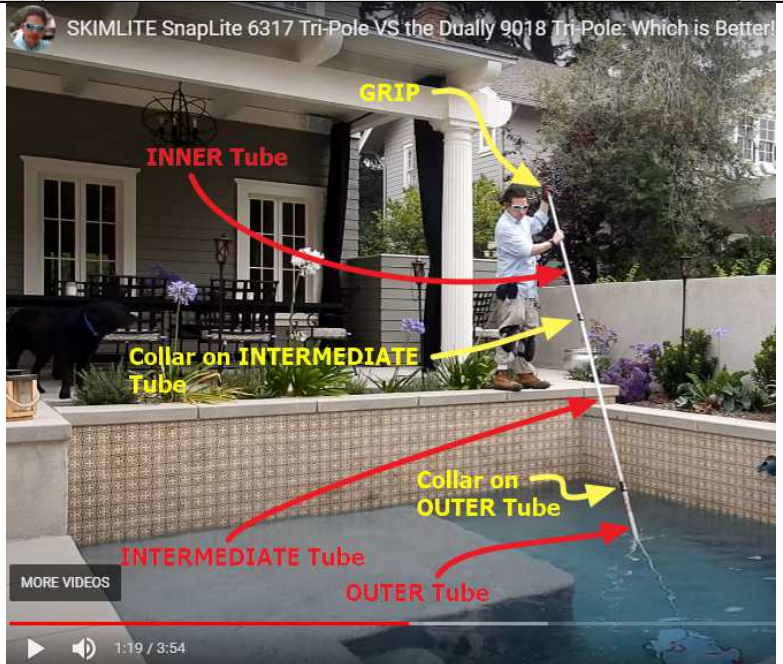

[From: <https://youtu.be/u5hTKelagiE?t=79>]

Because of the “intermediate tube” element in this claim, Plaintiff’s illustrations here are directed to examples of Defendants’ 3-piece infringing poles (ones that include an “intermediate tube”). As for the individual elements in Defendants’ 3-piece infringing poles (detent, collar, tube, plurality of detent holes, etc.), those generally correspond to the elements shown in other claims in this table. In the photograph above of Defendants’ 6317 pole, the outer tube’s first end has a collar containing a selectively actuatable detent, and the outer tube’s second end is in the pool water and includes structure for removably attaching a tool (with a tool shown attached).

1  
2  
3  
4  
5  
6  
7  
8  
9  
10  
11  
12  
13  
14  
15  
16  
17  
18  
19  
20  
21  
22  
23  
24  
25  
26  
27  
28

1  
2  
3  
4  
5  
6  
7  
8  
9  
10  
11  
12  
13  
14  
15  
16  
17  
18  
19  
20  
21  
22  
23  
24  
25  
26  
27  
28

**INDEPENDENT Claims of Plaintiff’s ‘852 Patent**

an inner tube having first and second ends, said first end of said inner tube including a grip attached to the inner tube for a user to grasp and manipulate the apparatus;

**Examples of Defendants’ Infringing Products (Model 6016 – 2 tubes; Model 6317 – 3 tubes)**



As shown above, Defendants’ 6317 pole has an inner tube with a first end including an attached grip for a user to grasp and manipulate the pole.



**INDEPENDENT Claims of Plaintiff’s ‘852 Patent**

an intermediate tube slidably interposed between said inner and outer tubes, said intermediate tube having first and second ends, said first end of said intermediate tube slidably received in the first end of said outer tube through an opening in said collar, said intermediate tube having a plurality of detent holes positioned to be engaged with said actuatable detent of said outer tube’s collar, said second end of said intermediate tube having a collar associated therewith, said collar containing a selectively actuatable detent;

**Examples of Defendants’ Infringing Products (Model 6016 – 2 tubes; Model 6317 – 3 tubes)**



As shown above, Defendants’ 6317 pole has an intermediate tube slidably interposed between the inner and outer tubes. The intermediate tube has a first end slidably received in the first end of said outer tube through an opening in the outer tube’s collar. The intermediate tube has a plurality of detent holes positioned to be engaged with the actuatable detent of the outer tube’s collar. The intermediate tube has a second end with a collar that contains a selectively actuatable detent (labeled above as “Collar on INTERMEDIATE Tube”).

1  
2  
3  
4  
5  
6  
7  
8  
9  
10  
11  
12  
13  
14  
15  
16  
17  
18  
19  
20  
21  
22  
23  
24  
25  
26  
27  
28

**INDEPENDENT Claims of Plaintiff’s ‘852 Patent**

said second end of said inner tube being slidably received in the second end of said intermediate tube through an opening in said intermediate tube’s collar, said inner tube having a plurality of detent holes positioned to be engaged with said actuatable detent of said intermediate tube’s collar;

**Examples of Defendants’ Infringing Products (Model 6016 – 2 tubes; Model 6317 – 3 tubes)**

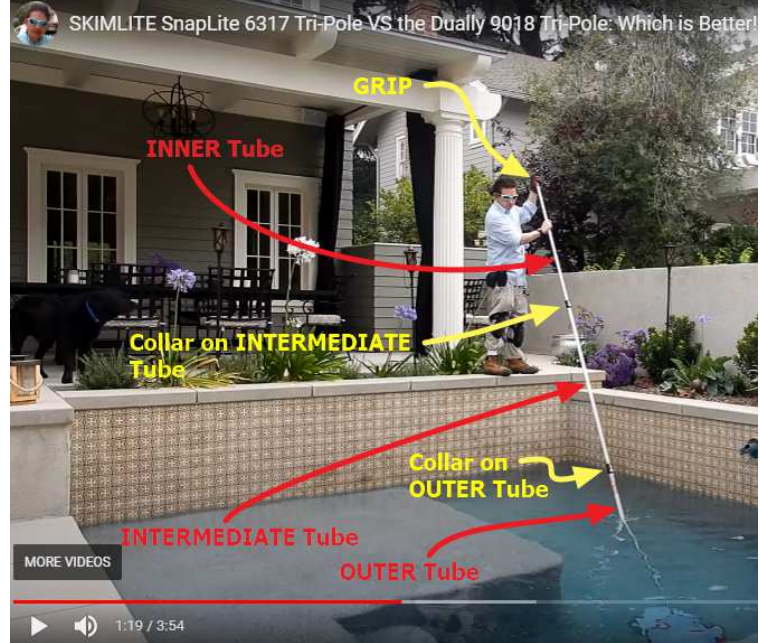

As shown above, Defendants’ 6317 pole has an inner tube with a second end (opposite the attached grip) that is slidably received in the second end of the intermediate tube through an opening in said intermediate tube’s collar, and the inner tube has a plurality of detent holes positioned to be engaged with the actuatable detent of the intermediate tube’s collar.

1  
2  
3  
4  
5  
6  
7  
8  
9  
10  
11  
12  
13  
14  
15  
16  
17  
18  
19  
20  
21  
22  
23  
24  
25  
26  
27  
28

**INDEPENDENT Claims of Plaintiff’s ‘852 Patent**

said intermediate tube configured to slide within said outer tube to a selectable position relative to said outer tube, at which position said detent of said outer tube is configured to temporarily engage and hold said intermediate tube; and

**Examples of Defendants’ Infringing Products (Model 6016 – 2 tubes; Model 6317 – 3 tubes)**



As shown above, Defendants’ 6317 pole has an intermediate tube configured to slide within the outer tube to a selectable position relative to the outer tube. At that position (such as shown above), the detent of the outer tube temporarily engages and holds the intermediate tube.

1  
2  
3  
4  
5  
6  
7  
8  
9  
10  
11  
12  
13  
14  
15  
16  
17  
18  
19  
20  
21  
22  
23  
24  
25  
26  
27  
28

**INDEPENDENT Claims of Plaintiff’s ‘852 Patent**

said inner tube configured to slide within said intermediate tube to a selectable position relative to said intermediate tube, at which position said detent of said intermediate tube is configured to temporarily engage and hold said inner tube.

**Examples of Defendants’ Infringing Products (Model 6016 – 2 tubes; Model 6317 – 3 tubes)**



As shown above, Defendants’ 6317 pole has an inner tube configured to slide within the intermediate tube to a selectable position relative to the intermediate tube. At that position (such as shown above), the detent of the intermediate tube temporarily engages and holds the inner tube.

21. An improved telepole device, comprising:



Defendants’ poles are telescoping pole devices.

1  
2  
3  
4  
5  
6  
7  
8  
9  
10  
11  
12  
13  
14  
15  
16  
17  
18  
19  
20  
21  
22  
23  
24  
25  
26  
27  
28

INDEPENDENT Claims of Plaintiff's '852 Patent	Examples of Defendants' Infringing Products (Model 6016 – 2 tubes; Model 6317 – 3 tubes)
<p>an outer tube element having first and second ends, said first end of the outer tube element having a collar element associated therewith, said collar element containing a detent means, said second end of the outer tube having attachment means for removably attaching a tool;</p>	<div data-bbox="820 275 1372 913" data-label="Image"> </div> <p>Much of this claim is already illustrated in this table, in connection with Claim 1 above. As further shown as black elements below, Defendants' poles include on the outer tube a collar element:</p> <div data-bbox="776 1123 1416 1285" data-label="Image"> </div>

1  
2  
3  
4  
5  
6  
7  
8  
9  
10  
11  
12  
13  
14  
15  
16  
17  
18  
19  
20  
21  
22  
23  
24  
25  
26  
27  
28

INDEPENDENT Claims of Plaintiff's '852 Patent	Examples of Defendants' Infringing Products (Model 6016 – 2 tubes; Model 6317 – 3 tubes)
	<p>and Defendants' collar element contains a detent means:</p>  <p>[Above, Defendant Barrett Conrad demonstrates how to assemble Defendants' lever/button and spring into Defendants' black collar/housing on the first end of Defendants' outer tube, to operate Defendants' actuatable detent] [SOURCE: <a href="https://www.youtube.com/watch?v=ldpzcFZJsW4">https://www.youtube.com/watch?v=ldpzcFZJsW4</a>; at 0:33 mark]</p>
<p>an inner tube element having first and second ends;</p>	<p>[This is virtually a repeat of a corresponding Claim 1 limitation above, so Plaintiff incorporates by reference the corresponding photographs and information above.]</p>

1  
2  
3  
4  
5  
6  
7  
8  
9  
10  
11  
12  
13  
14  
15  
16  
17  
18  
19  
20  
21  
22  
23  
24  
25  
26  
27  
28

<p><b>INDEPENDENT Claims of Plaintiff’s ‘852 Patent</b></p>	<p><b>Examples of Defendants’ Infringing Products (Model 6016 – 2 tubes; Model 6317 – 3 tubes)</b></p>
<p>said second end of said inner tube element being received in the first end of the outer tube through an opening in said collar element;</p>	<p>[This is virtually a repeat of a corresponding Claim 1 limitation above, so Plaintiff incorporates by reference the corresponding photographs and information above.] This photograph (from above) shows Defendants’ second end of their inner tube element being received in the first end of the outer tube through an opening in their black collar element:</p> 
<p>wherein said inner tube element is configured to readily slide within said outer tube element to a selected position along the length of the outer tube, and wherein said detent means is configured to temporarily lock the inner tube in that selected position within the outer tube.</p>	<p>[This is virtually a repeat of a corresponding Claim 1 limitation above, so Plaintiff incorporates by reference the corresponding photographs and information above.]</p>

**EXHIBIT D**

**Copying by Defendants and Other Competitors**

Below is a true and correct copy of further excerpts from U.S. Patent Office Records, Appl. Ser. No. 15/708,038 (from which Plaintiff’s ‘852 Patent issued); Third Supplemental Amendment and Response filed November 14, 2019, at pages 9, 10, 137, 138, and 139:

1  
2  
3  
4  
5  
6  
7  
8  
9  
10  
11  
12  
13  
14  
15  
16  
17  
18  
19  
20  
21  
22  
23  
24  
25  
26  
27  
28



File No. RESH-P3841.4

Serial No. 15/708,038

G. Reactions of Experts in the Field Show Applicant’s Inventions Are Not Obvious ..... 120

1. Upon Seeing Applicant’s DETENT-LOCKING Poles for the First Time, Competitor Skimlite/Jim Conrad GASPED and was SPEECHLESS! ..... 125
2. Mr. Conrad’s Reactions are “PARTICULARLY TRUSTWORTHY” Evidence that Applicant’s Inventions are Not Obvious ..... 127
3. Mr. Olmack’s Reactions Also are at Least Arguably “Reactions of Experts” Showing that Applicant’s Inventions are Not Obvious ..... 130

H. The Immediate and Extensive Copying of Applicant’s Pole Inventions, by at Least Four Competitors! ..... 131

1. Each of the Copiers (a) had Access to the Patented Product, and (b) Made a Pole Product Substantially Similarity to the “Patented” (and/or Patent Pending) Product ..... 132
2. Oreq Began Copying as Early as 2015 ..... 135
3. Skimlite Began Its Copying at Least as Early as 2015 ..... 137
  - a) Skimlite’s Subsequent Patent Application for its Copycat Poles Provides Further Evidence of Copying ..... 138
  - b) Skimlite/Conrad’s **Immediate** “Revisions” of Their Products (Just 18 Days After Filing Their Patent Application) Also Provides Even Further Evidence of Copying of Applicant’s Inventions/Products ..... 144
4. ProTuff/Henry Began Copying Efforts as Early as July 2016 by Filing Patent Application for its Copycat Poles ..... 151
  - a) ProTuff/Henry’s ORIGINAL 2016 Pole/Patent Application Includes Very Closely Spaced Adjustment Holes on its Inner Pole ..... 153
  - b) Around 2019, ProTuff/Henry CHANGED Its Pole to More Closely Copy Applicant’s Inventions/Products ..... 158
  - c) ProTuff/Henry Failed to Disclose to the Patent Office Applicant’s Patent Application and/or Pole Products ..... 175

1  
2  
3  
4  
5  
6  
7  
8  
9  
10  
11  
12  
13  
14  
15  
16  
17  
18  
19  
20  
21  
22  
23  
24  
25  
26  
27  
28

File No. RESH-P3841.4

Serial No. 15/708,038

1

2 d) The ProTuff/Henry Patent/Pole Has a Second

3 Pin/Button/Track on Its Inner Pole, That Apparently Serves

4 No Function Except to Make it Look LESS Like They Copied

5 Applicant's Inventions ..... 183

6 5. AquaEZ President Admitted Copying in November 2016..... 185

7 6. In Any Case, the Copiers Chose to NOT Copy the "Public

8 Domain" Lever-Locking Painter's Poles, but Instead Copied

9 Applicant's Inventions..... 186

10 7. It is ERROR to Discount This Evidence of Copying, in

11 Considering Whether Applicant's Inventions are Obvious..... 188

12 I. Applicant's Objective Evidence, Under Judge Learned Hand's

13 "Most Reliable Test" (or Any Appropriate Test for Obviousness)

14 Shows that Applicant's Inventions are NOT Obvious ..... 189

15 VI. If the Examiner Continues with Obviousness Rejections, the

16 Examiner Must "Articulate and Place on the Record" Reasons

17 Overcoming Applicant's Evidence of Objective Indicia of

18 Nonobviousness..... 200

19 VII. The Examiner's Rejections Appear to Demonstrate the Examiner's

20 Improper Use of Hindsight Reconstruction..... 201

21 A. The Examiner's "Form Template" Shows that the Examiner is Using

22 Improper Hindsight Reconstruction..... 203

23 B. Pansini Does Not Show Anything About TELESCOPING

24 Swimming Pool Poles ..... 205

25 C. The Remainder of the Examiner's Rejections "Template" Further

26 Shows Improper Hindsight Reconstruction..... 210

27 VIII. Applicant Has Amended Certain Claims to Further Define

28 Applicant's Claimed Collar Element ..... 224

IX. NO DISCLAIMERS OR DISAVOWALS ..... 232

File No. RESH-P3841.4

Serial No. 15/708,038

Oreq's "NEW" Pole Feature (from Oreq's 2015 catalog above)	Applicant's patent application (exemplary disclosures)
	ring, but it can make the compression ring very difficult to loosen and painful to the user's hands to twist the compression ring either to tighten or loosen it. (p. 7, l. 10-13)

In addition, pool man Dave Goulart confirms seeing Oreq's copycat pole at that September 2015 trade show, and seeing the features that Oreq copied from Applicant's products/inventions (Goulart par. 11-19).

3. **Skimlite Began Its Copying at Least as Early as 2015**

According to its own testimony in Federal Court, Skimlite began its copying of Applicant's invention in 2015. In that regard, below is an excerpt from

**Skimlite's related sworn court testimony in April 2018** (confirming that Skimlite

File No. RESH-P3841.4

Serial No. 15/708,038

had begun its research and development of the copycat pole in 2015, and had its first model "mid-2016 to early 2016"):

12

1 A. No.

2 Q. Did you read this patent?

3 A. Briefly.

4 Q. When did you become aware of it?

5 A. I don't have a date.

6 Q. When was it with respect to your R&D that started in 2015?

7 Did you have the patent then?

8 A. No.

9 Q. At some point you made the product that we put in front of

10 you and you began showing it. When was the first time that you

11 put your push-button-style pole out into the public?

12 A. Again, I don't have a set date, but I would say that we

13 had our first model mid-2016 to early 2016.

*a) Skimlite's Subsequent Patent Application for its Copycat Poles Provides Further Evidence of Copying*

As mentioned above, the patent application that Skimlite very recently filed (in March 2018) further confirms that Skimlite copied Applicant's inventions.

As explained below, the records in the Patent Office at least arguably show that the Patent Office itself believes that Skimlite's products are "substantially similar" to Applicant's claimed inventions. Specifically, and as shown in the

138

HTTPS://ELDOCS.LIVE/NET/064SD3A52SDW6PC/CLIENTS/RESH/P3841.4\_USPA\_POLE\_CONT\_3841\_LPTO\_COMMUNICATIONS/2019/04/01\_OA/2019-06-30\_3D\_SUPPL\_RESPONSE/DRAFTS/2019\_11\_14\_3D\_SUPPL\_RESP\_2019\_04\_01\_OA\_FINAL.DOCX

File No. RESH-P3841.4

Serial No. 15/708,038

prosecution excerpts below, in an Office Action just three months ago **the Patent Office rejected all of Skimlite's currently pending patent application claims based on Applicant's inventions.**

Skimlite filed its U.S. Pat. Appl. Ser. No. 15/932,534 application in early 2018, just a few weeks after Applicant's company sued Skimlite for patent infringement.<sup>28</sup> However, because Skimlite's application was published only a few weeks ago (in September 2019), Applicant only became aware of it very recently (Resh Second Decl., par. 22). Below are the front page and other excerpts from

<sup>28</sup> As mentioned in Applicant's other filings, Applicant's company served a Complaint for Skimlite infringing Applicant's previously-issued related patent (U.S. Pat. No. 9,764,458) on February 9, 2018. Skimlite filed its patent application for that copycat pole one month later, on March 12, 2018.