

FILED
U.S. DISTRICT COURT
EASTERN DISTRICT ARKANSAS

JAN 18 2022

**IN THE UNITED STATES DISTRICT COURT
FOR THE EASTERN DISTRICT OF ARKANSAS**

TAMMY H. DOWNS, CLERK
By: JLS **DEP CLERK**

**P. S. PRODUCTS, INC.,
BILLY PENNINGTON, Individually**

PLAINTIFFS

v.

Civil Action No. 4:22-cv-31-KGB-JTK

**ESTORES INTERNATIONAL, LLC
d/b/a PREMIER GUN CABINETS
d/b/a www.premierguncabinet.com**

DEFENDANTS

COMPLAINT

TO THE HONORABLE UNITED STATES DISTRICT COURT:

COMES NOW the Plaintiff, P.S. Products, Inc., and Mr. Billy Pennington, individually, hereafter ("PSP,") by and through its attorney, Chris H. Stewart of the Stewart Law Firm, files this Complaint against defendant eStores International, LLC, d/b/a Premier Gun Cabinets. (hereafter "GUNCABINETS") as follows:

JURISDICTION AND VENUE

1. This Court retains jurisdiction as patent infringement raises a federal question and is proper under 28 U.S.C. § 1331.
2. Pursuant to 28 U.S.C. § 1391, venue in this suit lies in the Eastern District of Arkansas because the actions which gave rise to the claims presented in this complaint occurred in Little Rock, Arkansas, within the Eastern District of Arkansas.
3. Additionally, the Eastern District of Arkansas has personal jurisdiction of the Defendants. Defendants have maintained substantial, continuous and systematic contacts with the state of Arkansas through its business dealings with customers in Arkansas. Furthermore, Defendant marketed its services and provided customer services to the state of Arkansas.

**This case assigned to District Judge Baker
and to Magistrate Judge Kearney**

4. Additionally, The Eastern District of Arkansas has personal jurisdiction of the Defendants because, among other things, Defendants are engaged in tortuous conduct within the state of Arkansas and in this District, including placing into commerce illegal copies of Plaintiffs' patented products via www.premierguncabinet.com, catalogs, tradeshow, third-party sellers and independent sale's agents.

**PARTIES RELEVANT TO
PLAINTIFFS' COMPLAINT FOR PATENT INFRINGEMENT**

5. This action is brought by P.S. Products, Inc., and its president, Mr. Billy Pennington, individually, manufacturers of stun guns, other personal security devices, gun cleaning kits and gun concealment items, organized within the state of Arkansas with its principal headquarters at 3120 Joshua Street, Little Rock, AR 72204.

6. eStores International, LLC, d/b/a Premier Gun Cabinets., (hereinafter "GUNCABINETS") is a corporation organized under the laws of the State of Louisiana and its principal place of business located at 17732 Highland Road, Ste. G217, Baton Rouge, LA 70810, with business activities throughout the world and the World Wide Web. GUNCABINETS offers for sale an infringing products and embodies the PSP Concealment Mantel Clock patent.

FACTUAL BASIS FOR THE CLAIMS ASSERTED

7. The Plaintiffs specialize in the manufacture and distribution of stun guns, stun devices, gun cleaning kits, gun concealment items and other personal protection devices.

8. The Plaintiffs market and sale its patented products through trade specialty shows, sales associates, retail stores, catalogs and through internet distribution throughout the United States.

9. The Defendant is a seller and importer of goods from China and sells the goods as retail and wholesale nationwide.

10. The Defendant uses tradeshow, catalog and business to business activities to sell its products.

11. The Defendant owns and operates the website www.premierguncabinet.com.

12. In May 22, 2009, PSP begin selling its product Concealment Mantel Clock (hereafter "CLOCK") under the brand name "Peace Keeper."

13. The product is manufactured in China.

14. PSP filed for a patent on the design of its clock on the July 27, 2009.

15. On February 9, 2010, United States Letters Patent No. US D609,582 S, were issued to the Plaintiffs for an invention for a Concealment Mantel Clock. See Exhibit A.

16. The Plaintiffs owed the patent throughout the period of the Defendants infringing acts and still owns the patent. See Figures 1 & 2. Below.

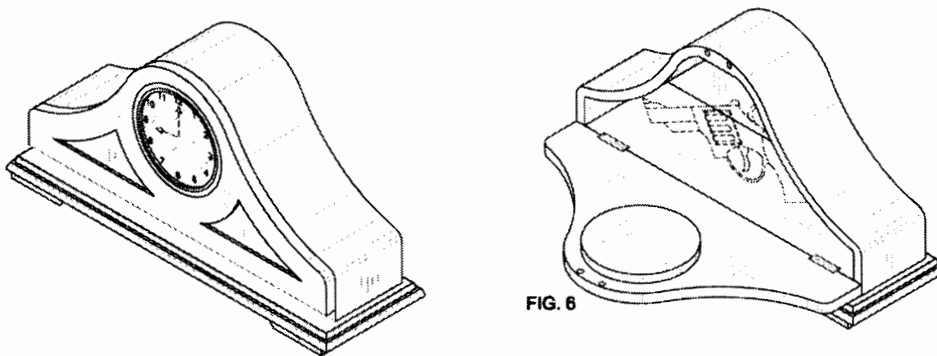

17. The Plaintiffs' product is one of a kind.

18. The Plaintiffs' designs are its own intellectual property. No goods of this design existed prior to the Plaintiffs' designs and patents.

19. The Plaintiffs are the only holder of patents on products of this kind in the United States.

20. The Plaintiffs makes significant revenue off of the CLOCK

21. The Plaintiffs have complied with the statutory requirement of placing a notice of Patent Pending and the Letters of Patent on all CLOCKS.

22. On information and belief the Plaintiffs learned that in December 2021 that the Defendant began selling an illegal product that embodied the Plaintiffs' patent.

23. The Defendant currently has the illegal products on its websites.

24. The Defendant has sold and continue to sell on their websites illegal copies of the Plaintiffs' patents and contributes to third parties selling illegal copies of the Plaintiffs' patents on its websites.

25. 35 U.S.C. § 271 states in part,

“(a) Except as otherwise provided in this title [35 USCS §§ 1 et seq.], whoever without authority makes, uses, offers to sell, or sells any patented invention, within the United States or imports into the United States any patented invention during the term of the patent therefore, infringes the patent. (b) Whoever actively induces infringement of a patent shall be liable as an infringer.”

26. The Defendant's actions have violated 35 U.S.C. § 271 and 15 U.S.C. § 1125.

27. The Defendant, intentionally, willfully, and wantonly violated 35 U.S.C. § 271 and 15 U.S.C. § 1125.

28. The Defendant without authority placed in the stream of commerce and offered to sell, the Plaintiffs' patented inventions, within the United States.

29. The Defendant without a licensed from the Plaintiffs placed in the stream of commerce and offered to sell, the Plaintiffs' patented inventions, within the United States.

30. The Defendant has induced individuals and companies to infringe on the Plaintiffs' patented products.

31. The Defendant has the infringing product currently for sale on its website listed below:

- a. <https://premierguncabinet.com/collections/hidden-gun-cabinets/products/hidden-gun-cabinet-handgun-mantel-clock>

32. A person with an internet connection may find the Defendants' illegal product on the websites listed above of the Induced Sellers.

37. The above identified sellers that sell and put the infringing product on their websites all do so with GUNCABINETS's express permission.

38. In addition to these infringing products, PSP also received from GUNCABINETS knock-off clock, representative pictures of which are provided below. See Fig. 3 Below.



39. The Accused devices available from GUNCABINETS through the websites above violate PSP's patent rights.

40. PSP's patent embodies the infringing product exposed for sale, offered for sale, and sold through GUNCABINETS induced sellers.

45. Defendants' exposing for sale, offering for sale, and selling the infringing Accused devices on GUNCABINETS's website violates PSP's intellectual property rights by warehousing

and/or offering for sale Accused devices, resulting in facilitation of third-party purchases of Accused Devices that violate PSP's intellectual property rights.

46. Likewise, on information and belief, at least the GUNCABINETS induced sellers import into the United States the Accused Devices, also violate PSP's intellectual property rights.

47. GUNCABINETS manages and controls the items that can be exposed for sale, offered for sale, and sold.

49. GUNCABINETS fulfills the sale of the products purchased by its buyers and induced sellers.

50. GUNCABINETS profits from the sale of infringing product.

51. But for GUNCABINETS and the GUNCABINETS induced sellers exposing for sale, offering for sale, and selling the Accused devices, PSP would not have been damaged nor would its intellectual property rights have been infringed.

52. After receiving notice of PSP's patent GUNCABINETS continued to induce third parties to sell counterfeit and illegal products.

53. GUNCABINETS chose to ignore PSP's notice because of the financial incentives it receives from sales.

54. GUNCABINETS' s willful and deliberate actions have caused significant harm to PSP.

55. GUNCABINETS infringes on PSP's patent rights.

56. GUNCABINETS has induced third parties to infringe on PSP's patent rights.

57. GUNCABINETS placed in the stream of commerce illegal products that are significantly cheaper than PSP' s product.

58. PSP has lost customers and revenue due to the illegal and infringing products being put in to the stream of commerce by GUNCABINETS.

FIRST CLAIM FOR RELIEF
PATENT INFRINGEMENT
35 U.S.C. § 271

59. PSP incorporates and re-alleges each of the allegations set forth above as though fully set forth herein.

60. GUNCABINETS infringed upon the rights of PSP's patent by exposing for sale, offering to sell, selling, and importing the infringing product in the United States.

61. GUNCABINETS will continue to infringe on the patent unless an injunction is granted by this Court.

62. GUNCABINETS acts are willful, in disregard of, and with indifference to, the rights of PSP.

63. As a direct and proximate cause of the infringement by GUNCABINETS, PSP is entitled to reasonable royalties and lost profits in amounts to be proven at trial, enhanced damages, and reasonable attorney's fees pursuant to 35 U.S.C. § 285. Additionally, GUNCABINETS induced sellers Defendants are liable to PSP to the extent of their total profits, but not less than \$250, pursuant to 35 U.S.C. § 289.

WHEREFORE, Plaintiff prays for relief as set forth below.

SECOND CLAIM FOR RELIEF
PATENT INFRINGEMENT BY INDUCEMENT
35 U.S.C. § 271(b)

64. PSP incorporates and re-alleges each of the allegations set forth above as though fully set forth herein.

65. GUNCABINETS has infringed upon the rights of PSP's patent by inducing individuals and companies to infringe upon the rights of PSP's patent.

66. GUNCABINETS, with knowledge of PSP's patent rights, has continued to allow the Accused Devices to be exposed for sale, offered for sale, and sold.

67. GUNCABINETS will continue to induce infringement of the patent through its sales activities unless enjoined by this Court.

68. GUNCABINETS's acts are willful, in disregard of, and with indifference to, the rights of PSP.

69. As a direct and proximate cause of the infringement by GUNCABINETS, PSP is entitled to reasonable royalties and lost profits in amounts to be proven at trial, enhanced damages, and reasonable attorney's fees pursuant to 35 U.S.C. § 285. Additionally, GUNCABINETS is liable to PSP to the extent of its total profit, but not less than \$250, pursuant to 35 U.S.C. § 289.

70. Defendants have literally and wilfully infringed upon Plaintiff's patent. Alternatively, Defendants have infringed under the doctrine of equivalents "in situations where there is no literal infringement but liability is nevertheless appropriate to prevent what is in essence

a pirating of the patentee's invention." GUNCABINETS'S infringing clock is substantially the same design.

PRAYER FOR RELIEF

WHEREFORE, Plaintiffs prays for judgment against Defendant, and each of them jointly and severally, as follows:

A. Judgment against the Defendant declaring that the Defendant's actions directly infringe on the Plaintiffs' patents Nos. US D609, 582 S;

B. Plaintiffs' reasonable royalties that may be proper under 35 U.S.C. § 284 in amounts to be proven at trial;

C. Plaintiffs' lost profits with respect to each patent infringement in amounts to be proven at trial;

D. The Defendants' profits from the illegal product.

E. Enhanced damages that may be proper under 35 U.S.C. § 284 with respect to each patent infringement for the Defendant's willful infringement;

F. A declaration that the Plaintiffs' case against the Defendant is an exceptional case pursuant to 35 U.S.C. § 285 and therefore subject to attorneys' fees;

G. An award of costs and attorneys' fee to the Plaintiffs; and,

H. Such other relief as the Court deems just and reasonable.

DEMAND FOR A JURY TRIAL

Plaintiffs demand a trial by jury as to all claims averred herein that are triable by jury.

Dated: January 16, 2022.

STEWART LAW FIRM

By: Chris H. Stewart
Ark. Bar No. 03-222
Attorney for Plaintiff
204 Executive Court, Ste. 031
Little Rock, AR 72205
Phone: 501-353-1364
Fax: 501-353-1263
Email: arklaw@comcast.net