

1 CHRISTINA J. MOSER
(S.B.N. 199027)
2 cmoser@bakerlaw.com
BRENDAN E. CLARK
3 (*pro hac vice to be applied-for*)
bclark@bakerlaw.com
4 BAKER & HOSTETLER LLP
Key Tower
5 127 Public Square, Suite 2000
Cleveland, OH 44114-1214
6 Telephone: 216.621.0200
Facsimile: 216.696.0740

7
8 *Attorneys for Plaintiffs*
Vita-Mix Corporation, Vita-Mix Management
9 Corporation, and Vita-Mix Manufacturing
Corporation

10 **IN THE UNITED STATES DISTRICT COURT**
11 **CENTRAL DISTRICT OF CALIFORNIA**
WESTERN DIVISION

12 Vita-Mix Corporation, 8615 Usher Rd,
Cleveland, OH 44138, Vita-Mix
13 Management Corporation, and Vita-Mix
Manufacturing Corporation

14 Plaintiffs,

15 v.

16 Vevor Corporation, 1172 Murphy
17 Avenue, Ste 237, San Jose, CA 95131,
Vevor Inc., Vevor Store Inc., HK
18 Sishun Trade Co., Sanven Corporation,
Sanven Technology Ltd., Shanghai
19 Sishun E-commerce Co., Ltd, Shanghai
SiShun Mechanical Equipment Co., Ltd,
20 Wildfiore Ltd, Rubao Jiao, and DOES
1-5

21 Defendants.
22

CASE NO.:

COMPLAINT

- 1. PATENT INFRINGEMENT
(35 U.S.C. § 271)
- 2. TRADE DRESS
INFRINGEMENT (15 U.S.C. § 1125)
- 3. UNFAIR COMPETITION
(CAL. BUS. & PROF. CODE §§
17200 *ET SEQ.*)

**[JURY DEMAND ENDORSED
HEREIN]**

23
24 Plaintiffs Vita-Mix Corporation, Vita-Mix Management Corporation, and
25 Vita-Mix Manufacturing Corporation, by and through their undersigned counsel,
26 for their Complaint against Defendants Vevor Corporation, Vevor Inc., Vevor
27 Store Inc., HK Sishun Trade Co., Sanven Corporation, Sanven Technology Ltd.,
28 Shanghai Sishun E-commerce Co., Ltd, Shanghai SiShun Mechanical Equipment

BAKER & HOSTETLER LLP
ATTORNEYS AT LAW
CLEVELAND

1
2
3
4
5
6
7
8
9
10
11
12
13
14
15
16
17
18
19
20
21
22
23
24
25
26
27
28

Co., Ltd, Wildfiore Ltd, and Rubao Jiao (collectively, “Defendants” or “Vevor Defendants”), hereby allege as follows:

- 1. This is a civil action for willful patent infringement under 35 U.S.C. § 271, willful Lanham Act trade dress infringement and unfair competition under 15 U.S.C. § 1125, and related state-law claims for unfair competition and deceptive trade practices under Cal. Bus. & Prof. Code §§ 17200 *et seq.*

THE PARTIES

- 2. Plaintiff Vita-Mix Corporation (“Vitamix Corp.”) is a corporation organized and existing under the laws of the State of Washington, having its principal place of business located at 8615 Usher Rd, Cleveland, OH 44138.
- 3. Plaintiff Vita-Mix Management Corporation (“Vitamix Management,” and with Vitamix “Plaintiffs”) is a corporation organized and existing under the laws of the State of Delaware, having its principal place of business located at 8615 Usher Rd, Cleveland, OH 44138.
- 4. Plaintiff Vita-Mix Manufacturing Corporation (“Vitamix Manufacturing”) is a corporation organized and existing under the laws of the State of Delaware, having its principal place of business located at 8615 Usher Rd, Cleveland, OH 44138.
- 5. Collectively, Vitamix Corp., Vitamix Management, and Vitamix Manufacturing are referred to herein as “Vitamix” or “Plaintiffs.”
- 6. The Plaintiffs are corporate siblings commonly owned under Vita-Mix Holdings Company, a Delaware corporation.
- 7. Upon information and belief, Defendant Vevor Corporation (“Vevor CA-1”) is a California corporation with a place of business at

1
2
3
4
5
6
7
8
9
10
11
12
13
14
15
16
17
18
19
20
21
22
23
24
25
26
27
28

1172 Murphy Avenue, Ste. 237, San Jose, CA 95131, and has appointed Angel Acuna of Christopher Huang CPAs, Inc., 1172 Murphy Avenue, Ste. 237, San Jose, California 95131, as its registered agent for service of process. On information and belief, Vevor CA-1 also has a place of business at 2875 S. Reservoir St., Pomona CA 91766.

8. In Vevor CA-1’s filings from October 2015, Rubao Jiao is identified as the Chief Executive Officer, Secretary, Chief Financial Officer, sole Director, and Incorporator for Vevor CA-1.
9. Upon information and belief, Vevor CA-1 has been suspended by the California Secretary of State.
10. Upon information and belief, Defendant Vevor Inc. (“Vevor CO”) is a Colorado corporation with a place of business at 4255 South Buckley Road #1316, Aurora, CO 80013, and has appointed Jin Wang, 4255 South Buckley Road #1316, Aurora, CO 80013, as its registered agent for service of process.
11. Vevor CO filed its articles of incorporation on April 6, 2021, listing Jin Wang as its registered agent at 4255 South Buckley Road #1316, Aurora, CO 80013, as well as its Incorporator at No. 58 Juxinyuan District 1, Bixi Town, Changshu City, 215500, Jiangsu Province, China.
12. Upon information and belief, Vevor CO has been placed in a delinquent status by the Colorado Secretary of State.
13. Vevor Store Inc. (“Vevor CA-2”) is a California for-profit corporation registered with the California Secretary of State, with a principal place of business at 9448 Richmond Place, Suite E, Rancho Cucamonga, CA 91730.

BAKER & HOSTETLER LLP
ATTORNEYS AT LAW
CLEVELAND

- 1 14. In Vevor CA-2’s most recent Statement of Information filing from
2 August 2022, Yanping Wang is identified as the Chief Executive
3 Officer, Secretary, Chief Financial Officer, sole Director,
4 Incorporator, and agent for service of process for Vevor CA-2.
- 5 15. Vevor CA-2 was originally incorporated as SSVEVOR LTD. Vevor
6 CA-2 filed a Certificate of Amendment with the California Secretary
7 of State on January 18, 2023 to change the entity’s name from
8 SSVEVOR LTD to Vevor Store Inc.
- 9 16. On information and belief, Vevor CA-2 sells Vevor products
10 including the infringing products that are the subject of this lawsuit.
- 11 17. On information and belief, Defendant HK Sishun Trade Co. (“HK
12 Sishun”) is a Chinese company located at RM 19H 19/F Maxgrand
13 Plaza, San Po Kong, KLN, Hong Kong, with Rubao Jiao as its sole
14 director.
- 15 18. On information and belief, HK Sishun handles payments from
16 purchasers of the infringing products that are the subject of this
17 lawsuit and receives payment or direct benefit for their administration
18 of payment processing for the Vevor Defendants’ U.S. customers.
- 19 19. Sanven Corporation (“Sanven”) is a California for-profit corporation
20 registered on July 29, 2013 with the California Secretary of State, with
21 a principal place of business at 9448 Richmond Place, Suite E, Rancho
22 Cucamonga, CA 91730.
- 23 20. The August 11, 2020 Statement of Information for Sanven identifies
24 Fuyu Jiao as the Chief Executive Officer, Secretary, Chief Financial
25 Officer, sole Director, Registered Agent, and Incorporator for Sanven.
26 Fuyu Jiao signed the Statement of Information filed on October 6,
27 2021, verifying that no changes had been made to Sanven.
- 28

- 1 21. Upon information and belief, Sanven imports the infringing products
2 that are the subject of this lawsuit and is otherwise involved in their
3 distribution throughout the United States.
- 4 22. Sanven Technology Ltd. (“Sanven Tech”) is a California for-profit
5 corporation registered on November 15, 2022 with the California
6 Secretary of State, with a principal place of business at
7 9448 Richmond Place, Suite E, Rancho Cucamonga, CA 91730.
- 8 23. Sanven Tech’s Articles of Incorporation indicates Fuyu Jiao as the
9 sole Director and Agent of Sanven Tech.
- 10 24. The November 16, 2022 Statement of Information for Sanven Tech,
11 signed by Fuyu Jiao, changed the address for Sanven Tech from
12 912 Cypress Avenue, Unit 505, Los Angeles, CA 90065 to
13 9448 Richmond Place, Suite E, Rancho Cucamonga, CA 91730.
- 14 25. Upon information and belief, Sanven Tech is involved in the
15 distribution of the infringing products that are the subject of this
16 lawsuit throughout the United States.
- 17 26. Shanghai Sishun E-commerce Co., Ltd. (“SSE”) is a Chinese
18 company located at Rm. J1016, Bldg 5, No. 3131, Jinshajiang Rd.,
19 Zhenxin St., Jiading Dist., Shanghai, China 201824, with Rubao Jiao
20 as its Executive Director and Legal Representative.
- 21 27. As described below, SSE is involved in the marketing and sale of the
22 infringing products that are the subject of this lawsuit, and owns over
23 fifty (50) VEVOR trademarks and trademark applications.
- 24 28. Upon information and belief, Defendant Shanghai SiShun Mechanical
25 Equipment Co., Ltd (“SSME”) is a Chinese company having a place
26 of business at Rm. 201, Bldg. 3, No. 3131, Jinshajiang Road, Jiading
27 District, Shanghai, China, 200000 with Rubao Jiao as its legal
28 representative.

BAKER & HOSTETLER LLP
ATTORNEYS AT LAW
CLEVELAND

- 1 29. Upon information and belief, SSME has a distribution warehouse
2 located at 1900 Proforma Avenue, Ste. E, Ontario, CA 91761.
- 3 30. Wildfiore Ltd (“Wildfiore”) is a California for-profit corporation
4 registered on June 1, 2021 with the California Secretary of State. The
5 postal address and agent’s address for Wildfiore is 17800 Castleton
6 Street, Suite 665, City of Industry, CA 91748.
- 7 31. Ruwen Jiao is identified as the Chief Executive Officer, Secretary,
8 Chief Financial Officer, sole Director, Registered Agent, and
9 Incorporator for Wildfiore.
- 10 32. As described below, Wildfiore is involved in the marketing and sale
11 of the infringing products that are the subject of this lawsuit, and owns
12 a federally-registered VEVOR trademark.
- 13 33. In the past three years, SSE has registered forty-nine different
14 trademark registrations, and filed five additional applications, for the
15 mark VEVOR across a wide variety of classes and goods with the U.S.
16 Patent and Trademark Office (“USPTO”), using nine different law
17 firms. Rubao Jiao is identified as the correspondent on at least one of
18 the VEVOR trademark registrations.
- 19 34. Francis H. Koh is the attorney of record for eight of the VEVOR
20 applications and registrations by SSE.
- 21 35. Kai Yu is the attorney of record for one of the VEVOR applications
22 by SSE.
- 23 36. Rubao Jiao is identified as the signatory and/or correspondent on at
24 least three trademark applications and registrations filed on behalf of
25 SSME, identifying SSME’s address as Rm 2090, East Zone, Bldg 4,
26 No. 3131, Jinshajiang Rd., Zhenxin St., Jiading Dist., Shanghai, China
27 201824.
- 28

BAKER & HOSTETLER LLP
ATTORNEYS AT LAW
CLEVELAND

1
2
3
4
5
6
7
8
9
10
11
12
13
14
15
16
17
18
19
20
21
22
23
24
25
26
27
28

37. During the past six years, Rubao Jiao has provided his contact information to the USPTO at least as follows:

Jiao Rubao
Long Hua Xin Qu
Wei Dong Long Ke Ji Da Sha 1331-1332
Shenzhen, Guangdong China 518109
Email: 2091592391@qq.com

Jiao Rubao
Long Hua Xin Qu
Wei Dong Long Ke Ji Da Sha 1331-1332
Shenzhen, Guangdong China 518109
Email: 3182203218@qq.com

Jiao Rubao
Longhua New District
Weidonglong Technology Building 1331-1332
Shenzhen, Guangdong, China 518109
Email: 2850712070@qq.com;
2853277606@qq.com
Telephone: 13670059854

Jiao Rubao
No.91-659-114,Nanyang Rd.
Chajian Town, Tianchang China
Email: 3004992166@qq.com

Jiao Rubao
91-659-114,Nanyang Road
Chajian Town, Tianchang, Anhui, China

38. Francis H. Koh and Kai Yu are the attorneys of record for two other SSME applications and registrations.

39. SSE and SSME are listed on various trade directories using the same description and company history, both claiming to be “Vevor” with a logistics warehouse and office in Los Angeles that cover distribution within North America.

40. On information and believe, SSE and/or SSME also operate warehouses in connection with Vevor products, including the accused product, in City of Industry, CA, Houston, TX, Perth Amboy, NJ, Austell, GA, Grove, NC, and Portland, OR.

1
2
3
4
5
6
7
8
9
10
11
12
13
14
15
16
17
18
19
20
21
22
23
24
25
26
27
28

- 41. Rubao Jiao filed to register the trademark VEVOR with the United States Patent and Trademark Office in 2015 as an individual with an address of 91-659-114, Nanyang Road, Chajian Town, Tianchang, Anhui, China.
- 42. That registration, U.S. Reg. No. 4858772, has been assigned several times, most recently to Shanghai Sishun E-Commerce Co., Ltd (with Rubao Jiao signing on behalf of both assignee and assignor) in 2019 and then to Wildfiore Ltd on June 28, 2021.
- 43. The current attorney of record for the 2015 VEVOR registration owned by Wildfiore Ltd is Francis H. Koh, Koh Law Firm, LLC, 4800 Hampden Lane, Suite 200, Bethesda, Maryland, 20814.
- 44. Upon information and belief, Rubao Jiao, Ruwen Jiao, and Fuyu Jiao are individuals who share a familial relationship.
- 45. Upon information and belief, Vevor CA-1, Vevor CA-2, Vevor CO, HK Sishun, Sanven, Sanven Tech, SSE, SSME, and Wildfiore are related entities, owned and operated as a mere shell, instrumentality or conduit for the business of the Jiao family as a single enterprise under the business name “Vevor” engaged in the import of, among other things, blenders from China to be sold in U.S. markets under the brand name Vevor—including the infringing products that are the subject of this lawsuit.
- 46. Upon information and belief, the Vevor Defendants were formed and/or operate for the purpose of copying popular American products and selling those inferior knock-offs at lower prices than the original, copied products. Various of the Vevor Defendants have been sued previously for intellectual property infringement, including one in which they admitted to willful infringement. *See infra.*

BAKER & HOSTETLER LLP
ATTORNEYS AT LAW
CLEVELAND

1
2
3
4
5
6
7
8
9
10
11
12
13
14
15
16
17
18
19
20
21
22
23
24
25
26
27
28

47. Upon information and belief, each of the Vevor Defendants materially participates in and benefits directly from the infringement described in this Complaint.

48. DOES 1-5 are persons who, upon information and belief, materially participate in, direct, authorize, and/or personally benefit from the infringing activities described herein.

JURISDICTION & VENUE

49. This Court has subject-matter jurisdiction over this action pursuant to 28 U.S.C. §§ 1331 and 1338.

50. In addition to having supplemental jurisdiction over Vitamix’s state claims pursuant to 28 U.S.C. § 1367, this Court has subject-matter jurisdiction pursuant to 28 U.S.C. § 1332 in that there is complete diversity of citizenship as between the parties and the amount in controversy exceeds \$75,000.00, exclusive of interest and costs.

51. This Court has personal jurisdiction over Vevor CA-1, Vevor CA-2, Sanven, Sanven Tech, and Wildfiore because they are corporations organized under the laws of California.

52. This Court has personal jurisdiction over Vevor CO because it is a Colorado entity that, upon information and belief, maintains at least one office in California through which it is involved in the marketing and sale of the infringing products that are the subject of this Complaint, and has committed acts of infringement in California.

53. This Court has personal jurisdiction over HK Sishun, SSE, and SSME because they are Chinese entities that, upon information and belief, maintain at least one warehouse and/or other offices in California through which they import, sell, and/or handle payments for the infringing products that are the subject of this Complaint to purchasers

1
2
3
4
5
6
7
8
9
10
11
12
13
14
15
16
17
18
19
20
21
22
23
24
25
26
27
28

throughout the United States, a significant portion of whom are located in California.

54. This Court has personal jurisdiction over Rubao Jiao because, upon information and belief, they have visited and/or resided in California for significant periods of time during which they conducted the infringing activity that is the subject of this Complaint, and established physical locations for Jiao family companies HK Sishun, SSE, and SSME in the Los Angeles area through which they personally engaged in, directed, and oversaw activity they knew to be infringing Vitamix’s intellectual property rights.

55. Venue is proper in this District and division pursuant to 28 U.S.C. §§ 1391(b), (c), and 1400(b) because the infringing products were sold from Pomona.

VITAMIX’S REPUTATION AND PRODUCTS

56. Founded 102 years ago, Vitamix is a leading manufacturer, seller, and supplier of blenders, food processing accessories, and food recycling equipment for home and business use.

57. Vitamix’s story began in the 1920s with a family-owned health food business founded by William Grover “Papa” Barnard. He shifted the business’ focus in 1939 to selling a new blending product called the “Vita-Mix” blender.

58. W.G. “Papa” Barnard appreciated how blenders could empower users to prepare healthy, delicious foods quickly and easily. He built Vitamix’s brand on this concept, and even created the country’s first infomercial in 1949 to advertise the original Vitamix blender.

- 1 59. Vitamix continued to innovate and grow through the 20th century. In
2 1969, Vitamix introduced a blender capable of handling everything
3 from hot soup to ice cream to dough, and even grinding grain.
- 4 60. Vitamix also created and published hundreds of recipes for its
5 customers to provide healthy eating options and inspire culinary
6 creativity using its products.
- 7 61. Vitamix’s success continued into the 21st century. In 2013 alone,
8 Vitamix opened a 175,000 square-foot operations center near its Ohio
9 headquarters and manufactured more than one million machines.
- 10 62. Vitamix continues to advance the state of the art in blenders, offering
11 new products and functionality while improving performance and
12 durability year after year.
- 13 63. Vitamix is still a family-owned company, with hundreds of employees
14 in Northeast Ohio.
- 15 64. Given this history, it is not surprising that Vitamix is the leading name
16 in commercial and household blenders and earned a reputation as a
17 technological pioneer in blenders. Vitamix and its affiliates own 174
18 U.S. patents and have applied for dozens more, a testament to its
19 enduring commitment to innovation and creativity. Vitamix has also
20 received a number of product awards, such as the 2014 “Kitchen
21 Innovation of The Year” Award.
- 22 65. Vitamix has a full line of commercial Vitamix machines that can be
23 found in gourmet restaurants and leading chains around the world.
- 24 66. In December 2009, Vitamix first offered its “The Quiet One®”
25 commercial blender (“The Quiet One®”). The Quiet One® is a best-
26 in-class commercial blender with state-of-the-art noise reduction
27 technology and unique ornamental features as well as distinctive trade
28 dress.

- 1 73. The 116 Patent claims, among other things, a base for a blender
2 comprising a generally flat bottom surface, a support flange creating
3 an enclosed internal cavity, an exhaust vent, a baffle projection, and
4 an outlet port.
- 5 74. The 655 Patent, entitled “Sealing Enclosure for a Blender,” was duly
6 and legally re-issued on August 18, 2015, and names David J. Kolar
7 and Stephen P. Rukavina as the inventors.
- 8 75. The 655 Patent claims, among other things, an enclosure for a blender
9 comprising a body portion adapted to be secured to a base of the
10 blender, the body portion including sidewalls, a flange, and a gasket.
- 11 76. The 308 Patent, entitled “Enclosure for a Blender,” was duly and
12 legally issued on re-issued on December 30, 2014, and names David
13 J. Kolar and Robert M. Ulanski as the inventors.
- 14 77. The 308 Patent claims, among other things, an enclosure for use with
15 a blender comprising a body portion, a foot, and a gasket that isolates
16 the enclosure from the base to prevent the transfer of vibrations
17 therebetween.
- 18 78. The 011 Patent, entitled “Blender Container and Cover,” was duly and
19 legally issued on August 26, 2014, and names Robert Ulanski as the
20 inventor.
- 21 79. The 011 Patent claims, among other things, a container for a blender
22 comprising a spout formed at a radiused corner and a cover including
23 a plug and a flap, said plug and said flap thereby sealing said spout.
- 24 80. The 084 Patent, entitled “Base of a Blender,” was duly and legally
25 issued on June 30, 2009, and names Paul K. Metaxatos, Steffen
26 F. Koury, Kurtis R. MacLaurin, Robert M. Ulanski, David J. Kolar,
27 Stephen P. Rukavina, Mark F. Fleming, and Anthony M. Ciepiel as
28 the inventors.

BAKER & HOSTETLER LLP
ATTORNEYS AT LAW
CLEVELAND

1
2
3
4
5
6
7
8
9
10
11
12
13
14
15
16
17
18
19
20
21
22
23
24
25
26
27
28

81. The 084 Patent claims an ornamental design for a base of a blender as excerpted below.

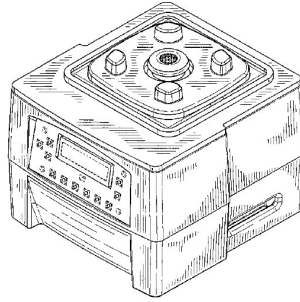

PLAINTIFF’S “THE QUIET ONE®” TRADE DRESS

82. Vitamix designed The Quiet One® for aesthetic appeal in addition to function.

83. The trade dress associated with The Quiet One® is inherently distinctive and has acquired strong secondary meaning.

84. Representative images of The Quiet One® are provided below, illustrating its distinctive trade dress.



85. Vitamix possesses trade dress rights in the base, enclosure, and container of The Quiet One®.

1
2
3
4
5
6
7
8
9
10
11
12
13
14
15
16
17
18
19
20
21
22
23
24
25
26
27
28

86. The base of Vitamix’s The Quiet One® includes a variety of distinctive, non-functional features distinguishing The Quiet One® from other blenders on the market. Such features include:
- a. the “pillars” at the left and right of the front surface of the base extending outward from recessed or tapered portions;
 - b. the flared front profile with an inflection below the middle of the base’s height, with both the top and bottom sloping away from the inflection;
 - c. the recessed arrangement of the front surface between the “pillars” below the inflection of the front surface;
 - d. the ornamental shape, positioning, and arrangement of the beveled air outlet ports on the sides of the base;
 - e. the accented controls and display, with blend speed buttons depicted by white triangles on black backgrounds at left, high and low pulse buttons depicting a portion of a square wave in white with the letters H and L in white on black backgrounds at right, numbered program buttons along the bottom with white numbers on a black background, and a rectangular display screen disposed at the center between the three groups of buttons; and
 - f. the black-on-black color scheme relating to base elements.
87. The enclosure of Vitamix’s The Quiet One® includes a variety of distinctive, non-functional features distinguishing The Quiet One® from other blenders on the market. Such features include:
- a. the ornamental arrangement of the cover overlapping the body portion of the enclosure;
 - b. the sinking recess extending down the center of the cover;
 - c. the positioning and footprint of the cross-cover handle;

- 1 d. the prominent, semi-transparent, shape and appearance of the
2 sockets and apertures defining the hinge between the cover and
3 body of the enclosure;
- 4 e. the curved, swooping cutaway contour of the sides of the cover;
- 5 f. the curved, swooping contour and the opaque material defining
6 the top and front of the body; and
- 7 g. the smoked color scheme of the transparent plastic of the
8 enclosure.
- 9 88. The container of Vitamix’s The Quiet One® includes a variety of
10 distinctive, non-functional features distinguishing The Quiet One®
11 from other blenders on the market. Such features include:
- 12 a. the profile and angles of the container handle;
- 13 b. the ornamental positioning and appearance of the graduated
14 lines for measuring an amount of fluid in the container;
- 15 c. the smoked color scheme of the transparent plastic in the
16 container;
- 17 d. recessed aspects at the base of the container; and
- 18 e. the contrasting black cover for the container.
- 19 89. The above-described elements of Vitamix trade dress are non-
20 functional and serve to distinguish The Quiet One® from competitor
21 products in the marketplace.
- 22 90. Vitamix has spent, and continues to spend, significant sums of money
23 to market, advertise, and promote The Quiet One®, and has
24 experienced extraordinary success in sales of The Quiet One®.
- 25 91. This success is due to the intellectual property embodied and
26 incorporated in The Quiet One®.
- 27 92. Trade dress incorporated in The Quiet One® has been come to be
28 known by the trade and purchasing public as indicators of source

1
2
3
4
5
6
7
8
9
10
11
12
13
14
15
16
17
18
19
20
21
22
23
24
25
26
27
28

pointing to the high-quality products and exclusive, innovative functionality provided by Vitamix. The Quiet One® trade dress, together with the associated goodwill, are of great value to Plaintiffs.

93. Due to the strength of the trade dress of The Quiet One®, it is the subject of copying by others.

94. Vitamix’s The Quiet One®, including the trade dress discussed herein, are available through a variety of channels, including direct from Vitamix’s website, through third-party retailers online, and in brick-and-mortar stores.

95. Vitamix maintains an official Amazon store through which it sells The Quiet One® directly to the public.

96. Due to the high-quality of and demand for The Quiet One®, there is also a sizable re-sale market for the product from secondary sources.

97. Through extensive, exclusive use of the trade dress in The Quiet One®, Plaintiffs have acquired valuable rights to the trade dress in The Quiet One® as a signifier of source, namely, high-quality, reliable products sold by Vitamix.

VEVOR’S BUSINESS AND REPUTATION

98. On information and belief, Defendants are related businesses that import and sell a wide variety of wares, including restaurant and food service products, to U.S. buyers under the Vevor name.

99. Vevor CA-1 has an “F” rating with the Better Business Bureau (“BBB”) due to unresolved customer complaints.

100. Sanven also has an “F” rating with the BBB.

101. The Vevor Defendants are aware of U.S. intellectual property laws as demonstrated by their extensive trademark filings and advertisements

1
2
3
4
5
6
7
8
9
10
11
12
13
14
15
16
17
18
19
20
21
22
23
24
25
26
27
28

- for “patented” features of the Vevor Defendants’ products on the vevor.com website.
102. None of the Vevor Defendants are identified as an inventor or assignee of any patents or any patent applications searchable via the U.S. Patent and Trademark Office Patent Assignment Search website.
103. The Vevor Defendants are also aware of the harm caused by intellectual property infringement, claiming that “[r]ecently, many sellers counterfeiting VEVOR emerged in the market, stealing our pictures and texts involving ultrasonic cleaners, distilled water machines, car refrigerators, distillers, etc., all of which are counterfeit and shoddy products.” See https://www.aliexpress.us/item/3256802720381438.html?gatewayAdapt=glo2usa4itemAdapt&randl_shipto=US (last accessed February 21, 2023) (“AliExpress Site”).
104. There is no evidence that any of the Vevor Defendants have pursued any alleged infringers of the Vevor Defendants’ intellectual property in a court of law, or that the Vevor Defendants have any intellectual property of their own to protect.
105. Vevor CA-1 and Vevor CO, along with other of the Defendants, have been sued at least six other times for allegedly infringing third-party patents, trademarks, and trade dress. Five of those lawsuits have been filed since December of 2021.
106. On January 21, 2016, Stahs’ Inc. sued Vevor CA-1, Sanven, and SSME in the U.S. District Court for the Eastern District of Michigan (2:16-cv10204-SJM-EAS) for patent infringement, trademark infringement, unfair competition, false advertising, copyright infringement, deceptive trade practices, and unjust enrichment. The parties settled the matter.

1
2
3
4
5
6
7
8
9
10
11
12
13
14
15
16
17
18
19
20
21
22
23
24
25
26
27
28

- 107. On July 6, 2020, General Wire Spring Company sued Vevor CA-1 in the U.S. District Court for the Northern District of California (3:20-cv-00087-RS) for trade dress infringement, trademark infringement, and unfair competition. Vevor CA-1 never answered and the court entered a default judgment.
- 108. On December 16, 2021, Motion Pro, Inc. sued Vevor CO in the U.S. District Court for the District of Colorado (1:21-cv-03380-CMA-SKC) for infringement of two patents. Vevor CO never answered the complaint.
- 109. On February 17, 2022, Schluter Systems, L.P. sued Vevor CA-1, Sanven, SSE, SSME, Wildfiore, Rubao Jioa, and Bai Nini (as well as Does 1–5) in the U.S. District Court for the Northern District of New York (8:22-cv-00155-TJM-CFH) for trademark infringement, unfair competition, and deceptive trade practices. Only Sanven answered. The parties settled and the case was dismissed on February 9, 2023.
- 110. On March 31, 2022, Summit Tool Company sued Vevor CA-1, Sanven, SSE, SSME, Wildfiore, and Rubao Jiao (as well as Does 1–5) in the Central District of California (2:22-cv-02161-AB-JC). The Defendants resolved the suit by consent judgment, admitting to willful infringement of the plaintiff’s intellectual property.
- 111. On June 22, 2022, Nautilus, Inc. sued Vevor CA-1, Vevor CO, Sanven, SSE, SSME, James Liu, Fuyu Jiao, and Rubao Jiao (as well as Does 1–5) in the U.S. District Court for the Central District of California for patent infringement, trademark infringement, false designation of origin, and unfair competition. Only Sanven and James Liu answered the complaint.

VEVOR'S INFRINGING PRODUCTS

- 1
- 2 112. The Vevor Defendants advertise, offer to sell, and sell blenders
- 3 throughout the United States through at least the e-commerce site
- 4 found at www.vevor.com, as well as third-party sites and e-commerce
- 5 platforms such as Amazon, Walmart, eBay, Home Depot, and Ali
- 6 Express.
- 7 113. On or about July 20, 2022, Vitamix learned that the Vevor Defendants
- 8 were selling a “VEVOR 110V Commercial Smoothie Blender,
- 9 1.5L/50.7oz 1500W Countertop Silent Blender” (“Vevor Silent
- 10 Blender”) with trade dress confusingly similar to Vitamix’s patented
- 11 The Quiet One®.
- 12 114. Advertised as adopting “QUIET blend technology” (*see* AliExpress
- 13 Site) the Vevor Defendants offered this competing “silent blender” for
- 14 \$157.99 to \$265.83, a fraction of the price that Vitamix and its
- 15 resellers charge for The Quiet One®.
- 16 115. Examples of the Vevor Defendants’ sales sites for the Vevor Silent
- 17 Blender are provided herewith as **Exhibit 6**, **Exhibit 7**, and **Exhibit 8**.
- 18 116. On October 14, 2022, Vitamix purchased a Vevor Silent Blender from
- 19 Vevor.com for analysis.
- 20 117. The payment receipt to for the Vevor Silent Blender purchased from
- 21 Vevor.com indicated that HK Sishun Trade Co., Limited
- 22 (investedzoe@outlook.com) received the payment for the purchase of
- 23 the Vevor Silent Blender.
- 24 118. The Vevor Silent Blender was received by Vitamix on October 19,
- 25 2022.
- 26 119. The Vevor Silent Blender, shown below next to the Vitamix The Quiet
- 27 One® blender looks substantially and strikingly similar to Vitamix’s
- 28 The Quiet One® and Vitamix’s trade dress therein, and likely to cause

BAKER & HOSTETLER LLP
ATTORNEYS AT LAW
CLEVELAND

1
2
3
4
5
6
7
8
9
10
11
12
13
14
15
16
17
18
19
20
21
22
23
24
25
26
27
28

consumer confusion as to the origin, sponsorship, or approval of the Vevor Silent Blender.



Vevor Silent Blender



The Quiet One®

120. The Vevor Silent Blender is also substantially the same as the patented design of the 084 Patent in the eye of an ordinary observer giving such attention as a purchaser usually gives to the non-functional ornamental design of the product, with such resemblance such as to deceive an ordinary observer, inducing him or her to purchase the Vevor Silent Blender supposing it to be the claimed design of the 084 Patent.



Vevor Silent Blender

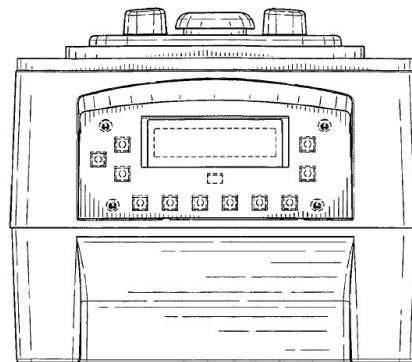

084 Patent

121. The structure on the underside of the base—the support flange, internal cavity, baffle, exhaust vents, and air outlet ports—claimed in

the 116 Patent, is also plainly copied from Vitamix based on the identical arrangement and function of those components.

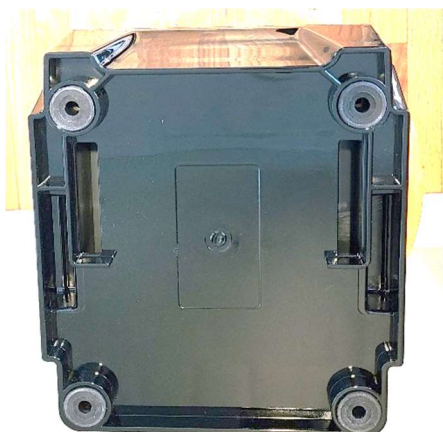

Vevor Silent Blender

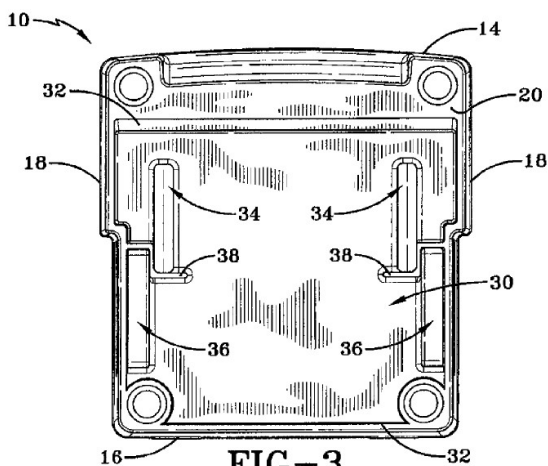

FIG-3
116 Patent

122. The container also includes several common elements covered by Vitamix’s trade dress and the 011 Patent.



Vevor Silent Blender



The Quiet One®

123. Despite the common trade dress, ornamental design, and functional components the Vevor Silent Blender not a genuine Vitamix product, nor is it sponsored by, or otherwise affiliated or associated with Vitamix.

BAKER & HOSTETLER LLP
ATTORNEYS AT LAW
CLEVELAND

- 1 124. Analysis of the Vevor Silent Blender indicated that it practices, and
2 therefore directly infringes, each and every element of at least one
3 claim from each of the utility Patents-in-Suit.
- 4 125. Vitamix sent fourteen (14) cease and desist letters to addresses
5 associated with Defendants on December 6 and 7, 2022. These
6 addresses included the addresses for Defendants’ U.S. registered
7 agents as well as Defendants’ business addresses in China. A true and
8 correct copy of a representative cease and desist letter to Defendants
9 is attached hereto as **Exhibit 9**.
- 10 126. Vitamix also sent electronic cease and desist letters to two email
11 addresses provided for legal issues on the vevor.com website,
12 IP@whosebilling.com and Legal@whosebilling.com.
- 13 127. It appears that, subsequent to Vitamix’s cease and desist letters, the
14 Vevor Defendants removed references to the email addresses
15 IP@whosebilling.com and Legal@whosebilling.com from
16 vevor.com.
- 17 128. The cease and desist letters demanded that the Vevor Defendants
18 confirm in writing that they would immediately cease and desist their
19 infringement and provide information to allow Vitamix to assess the
20 scope of the Vevor Defendants’ infringement.
- 21 129. The Vevor Defendants never responded to Vitamix’s mailed cease and
22 desist letters.
- 23 130. On December 7, 2022, dandan19951028@163.com (“Dandan”)
24 responded to the cease and desist letter emailed to
25 IP@whosebilling.com.
- 26 131. Dandan did not respond to details of the cease and desist letter but
27 stated that the Vevor Silent Blender had been removed and would not
28 be sold again. Dandan signed the response “VEVOR.”

- 1 132. On December 12, 2022, counsel for Vitamix contacted Dandan to
2 advise that the Vevor Defendants were still selling the Vevor Silent
3 Blender and that the Vevor Defendants had not provided the details
4 demanded in Vitamix’s cease and desist letter.
- 5 133. Dandan responded that same day, now stating that “the products on
6 our platform do not involve infringement” of five (5) of Vitamix’s
7 patents based on superficial analysis of just one claim element of a
8 single patent not asserted here, conceding by omission their knowing
9 infringement of the four (4) Patents-in-Suit.
- 10 134. Counsel for Vitamix again attempted to contact the Vevor Defendants
11 on December 18, 2022 and February 6, 2023 using the email addresses
12 for Dandan and IP@whosebilling.com, but did not receive any
13 response. A copy of the correspondence between counsel for Vitamix
14 and Dandan is provided herewith as **Exhibit 10**.
- 15 135. Upon information and belief, the Vevor Defendants continue to
16 intentionally, willfully, and knowingly manufacture, promote, market,
17 and sell their infringing Vevor Silent Blender in the United States of
18 America and within this District.
- 19 136. There is no way that the Vevor Defendants could reasonably believe
20 they had any right to use the patented instrumentalities incorporated
21 into The Quiet One®.
- 22 137. There is no way that the Vevor Defendants could reasonably believe
23 they were selling genuine Vitamix products or that they had any right
24 to copy the trade dress and patented ornamental design of The Quiet
25 One®.
- 26 138. The Infringing Products are marketed and sold in the same channels
27 as Vitamix’s genuine The Quiet One®, like Amazon.
- 28

- 1 139. Plaintiffs designed and manufactured The Quiet One® to conform to
2 exceedingly high-quality standards.
- 3 140. Based on Plaintiffs’ high-quality standards, The Quiet One® is backed
4 by an industry-leading three-year warranty on motor base parts and a
5 one-year warranty on other components for commercial use.
- 6 141. On information and belief, the Vevor Silent Blender is imported from
7 China and has a “directly manufacturer fully guarantee for 12 month.”
8 *See* AliExpress Site.
- 9 142. The Vevor Silent Blender is cheaply made and offered at a price that
10 is a fraction of a genuine Vitamix The Quiet One®.
- 11 143. Although it is obvious and apparent that the Vevor Defendants’ design
12 of their “silent blender” is a slavish, direct copy of Vitamix’s The
13 Quiet One® blender, at the very least the Vevor Defendants’
14 unauthorized practice of the Patents-in-Suit has been done with the
15 Vevor Defendants’ knowledge of Vitamix’s rights therein at least
16 since receipt of Vitamix’s cease and desist letters.
- 17 144. Through their willful, unauthorized use and practice of claims of the
18 Patents-in-Suit, the Vevor Defendants seek to profit from the
19 Plaintiffs’ patented inventions and Plaintiffs’ extensive experience
20 and investments required to develop those patented inventions.
- 21 145. The Vevor Defendants’ unauthorized use and practice of the Patents-
22 in-Suit has resulted in, is resulting in, and will continue to result in
23 harm to Vitamix.
- 24 146. The Vevor Defendants’ unauthorized use and copying of the Vitamix
25 trade dress has been done with the Vevor Defendants’ knowledge of
26 Vitamix’s rights therein; intent to trade on Vitamix’s goodwill therein;
27 and intent to cause confusion, mistake, or deception among
28 purchasers, potential purchasers, the trade, and the public.

BAKER & HOSTETLER LLP
ATTORNEYS AT LAW
CLEVELAND

1
2
3
4
5
6
7
8
9
10
11
12
13
14
15
16
17
18
19
20
21
22
23
24
25
26
27
28

- 147. Despite their actual knowledge of Vitamix’s patent and trade dress rights, the Vevor Defendants continue to engage in their infringing marketing campaigns.
- 148. Through their willful, unauthorized use and copying of The Quiet One® trade dress, the Vevor Defendants seek to profit from the success and reputation associated with The Quiet One®.
- 149. The Vevor Defendants’ unauthorized use and copying of The Quiet One® trade dress has resulted in, is resulting in, and will continue to result in harm to Vitamix, including without limitation, damage to Vitamix’s reputation and goodwill in The Quiet One® trade dress, as well as in monetary losses and damage.

COUNT I

(35 U.S.C. § 271 – Infringement of Pat. No. 8,690,116)

- 150. Plaintiffs incorporate the allegations in the preceding paragraphs of this Complaint as if fully set forth herein.
- 151. Upon information and belief, Defendants have been and are infringing at least claim 1 of the 116 Patent by making, using, selling, or offering for sale in the United States, or importing into the United States, including within this judicial district, the Vevor Silent Blender, in violation of 35 U.S.C. § 271(a).
- 152. Defendants’ infringement has been, and continues to be knowing, intentional, and willful.
- 153. Defendants’ acts of infringement of the 116 Patent have caused and will continue to cause Plaintiffs damages for which Plaintiffs are entitled to compensation pursuant to 35 U.S.C. § 284.
- 154. Defendants’ acts of infringement of the 116 Patent have caused and will continue to cause Plaintiffs immediate and irreparable harm

1
2
3
4
5
6
7
8
9
10
11
12
13
14
15
16
17
18
19
20
21
22
23
24
25
26
27
28

unless such infringing activities are enjoined by this Court pursuant to 35 U.S.C. § 283. Plaintiffs have no adequate remedy at law.

155. This case is exceptional and therefore Plaintiffs are entitled to an award of attorney fees pursuant to 35 U.S.C. § 285.

COUNT II

(35 U.S.C. § 271 – Infringement of Pat. No. RE45,655)

156. Vitamix incorporates the allegations in the preceding paragraphs of this Complaint as if fully set forth herein.

157. Upon information and belief, Defendants have been and are infringing at least claim 1 of the 655 Patent by making, using, selling, or offering for sale in the United States, or importing into the United States, including within this judicial district, the Vevor Silent Blender, in violation of 35 U.S.C. § 271(a).

158. Defendants’ infringement has been, and continues to be knowing, intentional, and willful.

159. Defendants’ acts of infringement of the 655 Patent have caused and will continue to cause Plaintiffs damages for which Plaintiffs are entitled to compensation pursuant to 35 U.S.C. § 284.

160. Defendants’ acts of infringement of the 655 Patent have caused and will continue to cause Plaintiffs immediate and irreparable harm unless such infringing activities are enjoined by this Court pursuant to 35 U.S.C. § 283. Plaintiffs have no adequate remedy at law.

161. This case is exceptional and therefore Plaintiffs are entitled to an award of attorney fees pursuant to 35 U.S.C. § 285.

1
2
3
4
5
6
7
8
9
10
11
12
13
14
15
16
17
18
19
20
21
22
23
24
25
26
27
28

COUNT III

(35 U.S.C. § 271 – Infringement of Pat. No. RE45,308)

162. Vitamix incorporates the allegations in the preceding paragraphs of this Complaint as if fully set forth herein.
163. Upon information and belief, Defendants have been and are infringing at least claim 1 of the 308 Patent by making, using, selling, or offering for sale in the United States, or importing into the United States, including within this judicial district, the Vevor Silent Blender, in violation of 35 U.S.C. § 271(a).
164. Defendants’ infringement has been, and continues to be knowing, intentional, and willful.
165. Defendants’ acts of infringement of the 308 Patent have caused and will continue to cause Plaintiffs damages for which Plaintiffs are entitled to compensation pursuant to 35 U.S.C. § 284.
166. Defendants’ acts of infringement of the 308 Patent have caused and will continue to cause Plaintiffs immediate and irreparable harm unless such infringing activities are enjoined by this Court pursuant to 35 U.S.C. § 283. Plaintiffs have no adequate remedy at law.
167. This case is exceptional and therefore Plaintiffs are entitled to an award of attorney fees pursuant to 35 U.S.C. § 285.

COUNT IV

(35 U.S.C. § 271 – Infringement of Pat. No. 8,814,011)

168. Vitamix incorporates the allegations in the preceding paragraphs of this Complaint as if fully set forth herein.
169. Upon information and belief, Defendants have been and are infringing at least claim 1 of the 011 Patent by making, using, selling, or offering for sale in the United States, or importing into the United States,

1
2
3
4
5
6
7
8
9
10
11
12
13
14
15
16
17
18
19
20
21
22
23
24
25
26
27
28

including within this judicial district, the Vevor Silent Blender, in violation of 35 U.S.C. § 271(a).

170. Defendants’ infringement has been, and continues to be knowing, intentional, and willful.

171. Defendants’ acts of infringement of the 011 Patent have caused and will continue to cause Plaintiffs damages for which Plaintiffs are entitled to compensation pursuant to 35 U.S.C. § 284.

172. Defendants’ acts of infringement of the 011 Patent have caused and will continue to cause Plaintiffs immediate and irreparable harm unless such infringing activities are enjoined by this Court pursuant to 35 U.S.C. § 283. Plaintiffs have no adequate remedy at law.

173. This case is exceptional and therefore Plaintiffs are entitled to an award of attorney fees pursuant to 35 U.S.C. § 285.

COUNT V

(35 U.S.C. § 271 – Infringement of Pat. No. D595,084)

174. Vitamix incorporates the allegations in the preceding paragraphs of this Complaint as if fully set forth herein.

175. Upon information and belief, Defendants have been and are infringing the 084 Patent by making, using, selling, or offering for sale in the United States, or importing into the United States, including within this judicial district, the Vevor Silent Blender, in violation of 35 U.S.C. § 271(a).

176. Defendants’ infringement has been, and continues to be knowing, intentional, and willful.

177. Defendants’ acts of infringement of the 116 Patent have caused and will continue to cause Plaintiffs damages for which Plaintiffs are entitled to compensation pursuant to 35 U.S.C. § 284.

- 1 178. Defendants’ acts of infringement of the 116 Patent have caused and
2 will continue to cause Plaintiffs immediate and irreparable harm
3 unless such infringing activities are enjoined by this Court pursuant to
4 35 U.S.C. § 283. Plaintiffs have no adequate remedy at law.
- 5 179. This case is exceptional and therefore Plaintiffs are entitled to an
6 award of attorney fees pursuant to 35 U.S.C. § 285.

7
8 **COUNT VI**
9 **(Lanham Act - 15 U.S.C. § 1125(A) – Infringement of**
10 **Trade Dress Infringement and Unfair Competition)**

- 11 180. Vitamix incorporates the allegations in the preceding paragraphs of
12 this Complaint as if fully set forth herein.
- 13 181. The distinctive appearance and impression of Vitamix’s The Quiet
14 One®, including the colors and geometries of the base, enclosure, and
15 container, the orientation and appearance of controls and
16 measurements, look-and-feel, and overall impression constitute
17 Vitamix’s commercial trade dress in The Quiet One®.
- 18 182. The trade dress in The Quiet One® is protectable, unique,
19 recognizable, and not merely functional.
- 20 183. With full knowledge and awareness of Plaintiffs’ ownership and prior
21 use of The Quiet One® trade dress, Defendants have willfully used,
22 are using, and will continue to use and offer the infringing Vevor
23 Silent Blender in a manner that is likely to cause confusion, to cause
24 mistake, or to deceive.
- 25 184. Defendants’ acts in using and offering the infringing Vevor Silent
26 Blender constitute trade dress infringement pursuant to § 43(a) of the
27 Lanham Act, 15 U.S.C. § 1125(a).
- 28 185. Defendants’ activities have caused and, unless enjoined by this Court,
will continue to cause a likelihood of confusion and deception among

1
2
3
4
5
6
7
8
9
10
11
12
13
14
15
16
17
18
19
20
21
22
23
24
25
26
27
28

members of the public and, additionally, injury to Plaintiffs’ goodwill and reputation as embodied in its trade dress, for which Plaintiffs have no adequate remedy at law.

186. Defendants’ actions demonstrate an intentional, willful, and malicious intent to trade on the goodwill associated with Plaintiffs’ trade dress resulting in significant and irreparable injury to Plaintiffs.

187. Defendants’ conduct has caused, and is likely to continue causing, substantial injury to the public and Plaintiffs, and Plaintiffs are entitled to injunctive relief and to recover Defendants’ profits, actual damages, enhanced profits and damages, costs, and reasonable attorneys’ fees pursuant to 15 U.S.C. §§ 1116, 1117, and 1125.

COUNT VII

(California Business & Professions Code, § 17200 *et seq.*)

188. Vitamix incorporates the allegations in the preceding paragraphs of this Complaint as if fully set forth herein.

189. Vitamix has prior rights in and to the trade dress of The Quiet One®.

190. The Vevor Defendants, in the course of their businesses, engaged in acts—namely, their unauthorized use and copying of The Quiet One®—that caused a likelihood of confusion or misunderstanding as to the source of, or sponsorship or approval by, Vitamix of the Vevor Defendants’ products.

191. The Vevor Defendants, in the course of their businesses, engaged in acts—namely, their unauthorized use and copying of The Quiet One®—that caused a likelihood of confusion or misunderstanding as to the Vevor Defendants’ affiliation, connection, and/or association with Vitamix.

1 198. For the same reasons stated above, the Vevor Defendants’ foregoing
2 unauthorized use and copying of The Quiet One® are willful, wanton,
3 intentional, and undertaken in bad faith, and Vitamix is entitled to
4 recover actual damages in an amount to be proven at trial, treble
5 damages, additional damages, and attorneys’ fees.

6
7 **WHEREFORE**, Plaintiffs respectfully pray that this Court grant the following
8 relief as to each of the above causes of action:

9 a. Preliminarily and permanently enjoin each Defendant and their
10 respective affiliates, subsidiaries, divisions, officers, agents,
11 employees, representatives, privies, successors, assigns and all those
12 acting for them or on their behalf, or acting in concert with them
13 directly or indirectly from: (i) advertising, marketing, promoting,
14 manufacturing, exporting, importing, distributing, offering for sale or
15 selling the Vevor Silent Blender, or any product practicing any claim
16 of the Patents-in-Suit;

17 b. Preliminarily and permanently enjoin each Defendant and their
18 respective affiliates, subsidiaries, divisions, officers, agents,
19 employees, representatives, privies, successors, assigns and all those
20 acting for them or on their behalf, or acting in concert with them
21 directly or indirectly from: (i) advertising, marketing, promoting,
22 manufacturing, exporting, importing, distributing, offering for sale or
23 selling the Vevor Silent Blender, or any product incorporating The
24 Quiet One® trade dress or any similar trade dress that it is likely to
25 cause confusion, mistake, or deception among the trade or public;
26 and/or (ii) doing any other thing calculated or likely to cause
27 confusion or mistake in the mind of the trade or public or to deceive
28 the trade or public into believing that the Vevor Defendants’ products

- 1 are in any way associated or affiliated with or sponsored or endorsed
2 by Vitamix;
- 3 c. Issue an order directing all businesses located at 2875 S. Reservoir St.,
4 Pomona CA 91766, 1172 Murphy Avenue, Ste. 237, San Jose, CA
5 95131, 912 Cypress Avenue, Unit 505, Los Angeles, CA 90065,
6 17800 Castleton Street, Suite 665, City of Industry, CA 91748, 1900
7 Proforma Avenue, Ste. E, Ontario, CA 91761, and 9448 Richmond
8 Place, Suite E, Rancho Cucamonga, CA 91730 to segregate, preserve,
9 and produce for inspection all Infringing Products and all documents
10 showing the number of units of Infringing Products sold, received,
11 and/or shipped, all customers who purchased Infringing Products, and
12 the individuals involved in the creation, manufacture, shipping,
13 import, sale, marketing, and/or distribution of Infringing Products;
- 14 d. Issue an order directing Amazon, eBay, Walmart, Home Depot, Ali
15 Express, and other third-party sellers of the Vevor Defendants'
16 products to permanently remove product listings of the Vevor Silent
17 Blender and to refrain from listing on their platforms on behalf of
18 Defendants or any other person any blenders made or sold by any of
19 the Vevor Defendants that practice any claim of the Patents-in-Suit or
20 are confusingly similar to The Quiet One® or that use The Quiet
21 One® trade dress;
- 22 e. Grant Vitamix an equitable accounting of the Vevor Defendants'
23 profits, if any, from the sale of their infringing goods, and award
24 Vitamix judgment for its damages and/or the Vevor Defendants'
25 profits arising from the Vevor Defendants' infringement of and
26 activities with respect to the Patents-in-Suit or The Quiet One® trade
27 dress, including pre- and post-judgment interest thereon;
- 28 f. Award Vitamix actual damages under 35 U.S.C. § 284, arising from

- 1 the Vevor Defendants’ infringement of the Patents-in-Suit, including
2 pre- and post-judgment interest thereon;
- 3 g. Award Vitamix treble damages under 35 U.S.C. § 284 due to the
4 intentional, willful, and wanton nature of the Vevor Defendants’
5 infringement of the Patents-in-Suit, and for the same reasons declare
6 the above-referenced matter an exceptional case under 35 U.S.C.
7 § 285 and award Vitamix its attorneys’ fees;
- 8 h. Award Vitamix actual damages under 15 U.S.C. § 1117 arising from
9 the Vevor Defendants’ violation of 15 U.S.C. § 1125(a), including
10 pre- and post-judgment interest thereon;
- 11 i. Declare that, due to the intentional, willful, and wanton nature of the
12 Vevor Defendants’ activities, the above-referenced matter is an
13 exceptional case under 15 U.S.C. § 1117, and award Vitamix treble
14 damages, additional damages, attorneys’ fees, and/or costs
15 thereunder;
- 16 j. Award Vitamix damages in an amount to be proven at trial, treble
17 damages, additional damages, and/or attorneys’ fees for the Vevor
18 Defendants’ violations of Cal. Bus. & Prof Code § 17200 *et seq.*;
- 19 k. Award Plaintiffs damages in an amount to be proven at trial, treble
20 damages, additional damages, and/or attorneys’ fees for the Vevor
21 Defendants’ violations of California’s common law unfair
22 competition;
- 23 l. Grant Plaintiffs any such other and/or additional relief as this Court
24 deems just, proper, and/or equitable.

25
26 **JURY DEMAND**

27 Vitamix hereby demands a jury trial on all issues so triable.
28

1 Dated: March 1, 2023

Respectfully submitted,

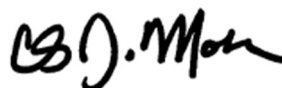
2 

3
4 Christina J. Moser
(S.B.N. 199027)
cmoser@bakerlaw.com

5 Brendan E. Clark
(*pro hac vice to be applied-for*)
bclark@bakerlaw.com

6
7 BAKER & HOSTETLER LLP
8 Key Tower
9 127 Public Square, Suite 2000
10 Cleveland, OH 44114-1214
11 Telephone: 216.621.0200
12 Facsimile: 216.696.0740

13 *Attorneys for Plaintiffs*
14 *Vita-Mix Corporation,*
15 *Vita-Mix Management Corporation, and*
16 *Vita-Mix Manufacturing Corporation*

17
18
19
20
21
22
23
24
25
26
27
28
BAKER & HOSTETLER LLP
ATTORNEYS AT LAW
CLEVELAND