

IN THE UNITED STATES DISTRICT COURT
FOR THE DISTRICT OF DELAWARE

LUND MOTION PRODUCTS, INC.)	
d/b/a AMP RESEARCH,)	
)	
Plaintiff,)	
)	
v.)	C.A. No. _____
)	
ROUGH COUNTRY, LLC.,)	JURY TRIAL DEMANDED
)	
Defendant.)	

COMPLAINT FOR PATENT INFRINGEMENT

Plaintiff Lund Motion Products, Inc. d/b/a AMP Research (“Plaintiff” or “Lund”) hereby complains of Defendant Rough Country, LLC (“Defendant” or “Rough Country”) and alleges as follows:

THE PARTIES

1. Plaintiff Lund Motion Products, Inc. d/b/a AMP Research is a Delaware corporation having a principal place of business at 3172 Nasa Street, Brea, CA 92821.

2. Upon information and belief, Defendant Rough Country is a Delaware corporation with a registered address of 850 New Burton Road Suite 201, Dover, Delaware 19904 and a principal place of business at 2450 Huish Road, Dryersburg, Tennessee 38024.

JURISDICTION AND VENUE

3. Lund repeats, realleges and reincorporates by reference the allegations set forth in paragraphs 1 through 2.

4. Lund asserts claims for patent infringement arising under the patent laws of the United States, 35 U.S.C. § 100 *et seq.*, more particularly 35 U.S.C. §§ 271 and 281. This court has original subject matter jurisdiction pursuant to 28 U.S.C. §§ 1331 and 1338.

5. Upon information and belief, Rough Country is engaged in the business of offering for sale in, selling in, and/or importing into the United States retractable step products, including within this District, and is incorporated in this District.

6. Rough Country is subject to the general personal jurisdiction of courts of general jurisdiction in Delaware because Rough Country is incorporated in Delaware. *Daimler AG v. Bauman*, 571 U.S. 117, 137 (2014); *Genuine Parts Co. v. Cepec*, 137 A.3d 123 (Del. 2016). As such, this court may exercise jurisdiction over Rough Country pursuant to Rule 4(k)(1) of the Federal Rules of Civil Procedure.

7. Upon information and belief, Rough Country resides in the District of Delaware by virtue of being incorporated in Delaware. Therefore, venue is proper in this judicial district pursuant to 28 U.S.C. §§ 1391(b)(1) and 1400(b).

THE PATENTS-IN-SUIT

8. Lund repeats, realleges and reincorporates by reference the allegations set forth in paragraphs 1 through 7.

9. Lund is the owner by assignment of U.S. Patent No. 9,272,667 (“the ’667 Patent”), entitled “Automated Retractable Vehicle Step,” which the United States Patent and Trademark Office lawfully and duly issued on March 1, 2016. A true and correct copy of the ’667 Patent is attached hereto as **Exhibit A**.

10. Lund is the owner by assignment of U.S. Patent No. 9,527,449 (“the ’449 Patent”), entitled “Controlling a Powered Vehicle Step,” which the United States Patent and Trademark

Office lawfully and duly issued on December 27, 2016. A true and correct copy of the '449 Patent is attached hereto as **Exhibit B**.

11. Lund is the owner by assignment of U.S. Patent No. 9,511,717 (“the ’717 Patent”), entitled “Automated Retractable Vehicle Step,” which the United States Patent and Trademark Office lawfully and duly issued on December 6, 2016. A true and correct copy of the ’717 Patent is attached hereto as **Exhibit C**.

12. Lund is the owner by assignment of U.S. Patent No. 11,198,395 (“the ’395 Patent), entitled “Automated Retractable Vehicle Step,” which the United States Patent and Trademark Office lawfully and duly issued on December 14, 2021. A true and correct copy of the ’395 Patent is attached hereto as **Exhibit D**.

FACTUAL ALLEGATIONS

13. Lund repeats, realleges and reincorporates by reference the allegations set forth in paragraphs 1 through 12.

14. AMP Research is a research and manufacturing company specializing in the innovation and development of aftermarket vehicle parts. AMP Research developed and has sold its PowerStep™ line of products which feature electric automatic vehicle steps that deploy when the vehicle doors are open and retract when the vehicle doors close. AMP Research pioneered “plug-and-play” technology that allows the retractable step system to communicate directly with the vehicle’s existing computer system.

15. In 2013, Lund acquired all the assets of AMP Research and continued development and sales of the PowerStep™ products. Lund assembles and manufactures all of its PowerStep™ products in the United States. The PowerStep™ products have become very well known in the industry and several major automotive manufactures—including Lincoln, Cadillac, GMC,

Chevrolet, Range Rover, and Chrysler—have offered the PowerStep™ products as a factory option or as an accessory. Lund has continued commercializing the PowerStep™ products under the AMP Research brand.

16. Lund has a large patent portfolio covering its innovative retractable vehicle steps, including the '667 Patent, the '449 Patent, the '717 Patent, and the '395 Patent (collectively the “Asserted Patents.”)

17. The Specialty Equipment Market Association (SEMA) trade show in Las Vegas, Nevada is touted as the “premier automotive specialty products trade event in the world” and draws more than 70,000 domestic and international buyers. Lund and AMP Research have been the recipients of several SEMA awards throughout the years. For example, Lund’s PowerStep XL™ product was the winner of the 2014 and 2015 SEMA New Product Award in the category of Exterior Accessory Products. Further, Lund’s PowerStep XL™ product was featured on the 2016 SEMA Show Hottest Truck winner, the ‘16/’17 Ford F-250 Super Duty Truck.

18. In recent years, foreign manufacturers have begun manufacturing retractable vehicle steps that infringe Lund’s patents and, without license, contract, or permission from Lund, have sold them globally, including to distributors in the United States.

19. One such company, which operates under several aliases and subsidiaries including Anhui Aggeus Auto-Tech Co., Ltd., Wuhu Woden Auto Parts Co., Ltd., Wuhu Wow-good Auto-tech Co. Ltd., and Anhui Wollin International Co., Ltd. (hereinafter collectively described as “Woden”), is a Chinese manufacturing firm operating out of Wuhu, Anhui, an industrial city in eastern China.

20. Upon information and belief, Rough Country is currently selling, offering for sale, and/or importing the infringing Woden retractable step products.

21. For example, upon information and belief, Rough Country rebrands the retractable step products as Retract Step Kits (“the Accused Products”) (see, e.g. **Exhibit E**). Rough Country sells and/or offers for sale the Accused Products by way of direct orders placed on the RoughCountry.com website. *Id.* Rough Country sells and offers to sell Accused Products that are advertised as compatible with specific Ford, Toyota, Ram, Chevy/GMC, and Jeep vehicles. *Id.*

22. Upon information and belief, Rough Country ships the Accused Products nationwide, including in and to this District (see, e.g., a copy of a Rough Country webpage attached as **Exhibit F** (“This item ships free to the continental US”)). The Accused Products are shipped packaged with Rough Country-branded installation instructions (see, e.g., **Exhibit G**).

23. Rough Country also contracts with numerous “authorized Rough Country dealers” across the nation (see <https://www.roughcountry.com/dealer-locator/>). Upon information and belief, Rough Country ships Rough Country products, including the Accused Products, to said dealers, who act as “distributors,” offering retail and installation services (see <https://www.roughcountry.com/dealer-program>). Upon information and belief, Rough Country authorizes at least six auto parts companies in this District for “Truck Accessory Installation” (see, e.g. <https://www.roughcountry.com/dealer-locator/sound-fx-inc/>).

24. Rough Country has been on notice of at least the ’667, ’449, and ’717 Patents over retractable step technology since March 16, 2021, via correspondence from Lund. Rough Country has been on notice of the ’395 Patent at least since January 31, 2022.

25. Additionally, given the industry-leading status of Lund’s PowerStep™ products and Rough Country’s business of manufacturing, selling, and importing aftermarket accessories for trucks, Rough Country was necessarily aware of the PowerStep™ products when Rough Country marketed, sold, offered for sale, and imported its competing Accused Products.

26. Upon information and belief, Rough Country attended or exhibited products at SEMA in at least 2008 and 2016.

27. Upon information and belief, Rough Country's decision to sell and import into the United States the Accused Products was done with knowledge of, or willful blindness to, the Asserted Patents.

28. Upon information and belief, Rough Country's decision to launch the Accused Products was done with knowledge, or willful blindness to the known risk, that the Accused Products would infringe one or more of the Asserted Patents.

29. Upon information and belief, Rough Country's actions were egregious, willful, wanton, and done with reckless or callous disregard of, or with indifference to, Lund's rights.

FIRST CLAIM FOR RELIEF:

INFRINGEMENT OF THE '667 PATENT

30. Lund repeats, realleges and reincorporates by reference the allegations set forth in paragraphs 1 through 29.

31. Upon information and belief, the Accused Products infringe at least Claim 1 of the '667 patent under 35 U.S.C. § 271(a) either literally or under the doctrine of equivalents.

32. Upon information and belief, Rough Country has directly infringed one or more of the claims of the '667 patent through the manufacture, use, offering for sale, and/or selling within the United States, and/or importation into the United States, of retractable step products including the Accused Products in violation of 35 U.S.C. § 271(a).

33. For example, upon information and belief, the Accused Products, including the "Retract Step Kit Lighted | Crew Cab | Chevy/GMC 1500/2500HD (19-22)," include all the limitations of Claim 1 of the '667 patent.

34. The Accused Products include a powered retractable vehicle step assist system configured for use with a vehicle (see **Exhibit F**).



35. The Accused Products include a stepping member having a stepping surface and movable between a retracted position and a deployed position with respect to the vehicle (see **Exhibit F** (“These durable electric side steps feature a motorized ‘swing-out’ function that instantly extends the step when you open the door. ... Once the door closes, the step automatically tucks away for a clean look.”)).

36. The Accused Products include at least one support member connectable with respect to an underside of the vehicle and connected to the stepping member. The support member is configured to at least partially support the stepping member with respect to the vehicle (see **Exhibits F and G**).

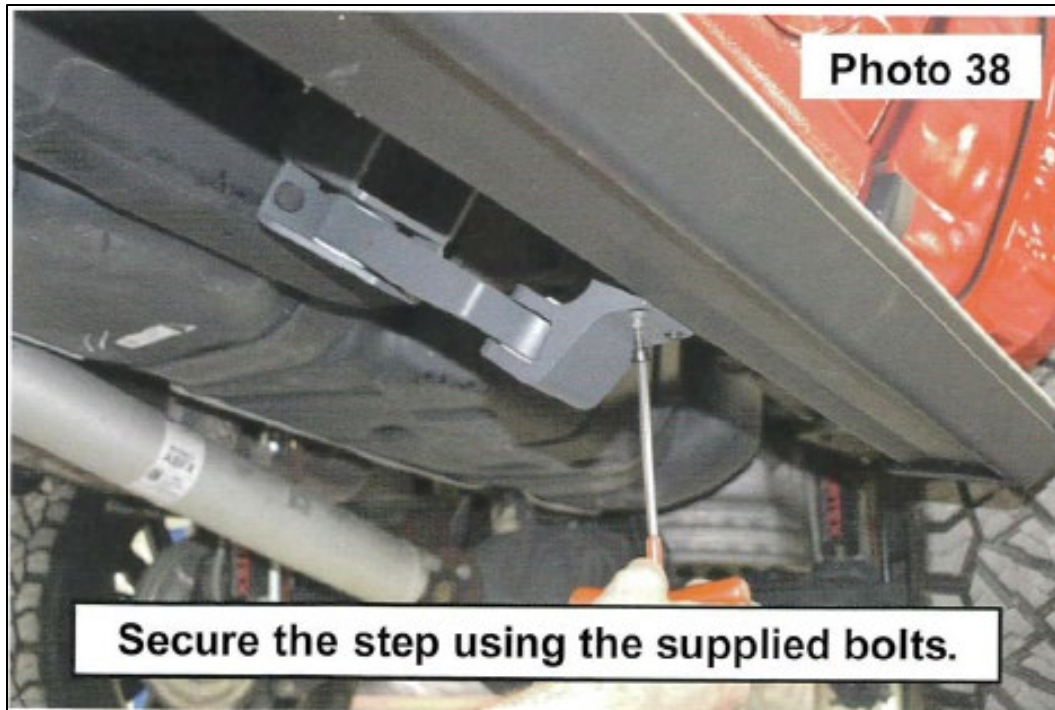

37. The Accused Products include a motor operably coupled to the support member and capable of effectuating movement of the stepping member from the retracted position to the deployed position (see **Exhibit F** (“These durable electric side steps feature a motorized ‘swing-out’ function that instantly extends the step when you open the door.”) and **Exhibit G** (“37. Test the motors by opening and closing each door 38. Open one door on each side. With the motor and idler arms extended outward, install one step board onto the mounts.”)).

38. The Accused Products include a vehicle interface configured to connect with an already existing electronics port of the vehicle, namely the OBDII port. Upon information and belief, the vehicle interface is configured to electronically receive data via the existing electronics port, the data generated by existing electronics of the vehicle. See **Exhibit F** (“Rough Country’s retractable truck steps ... connect[] directly to your battery terminal and OBDII port.”); see also **Exhibit G** (“[T]he wiring harness” of the Accused Products is connected to “the stock OBDII port” during installation.”)

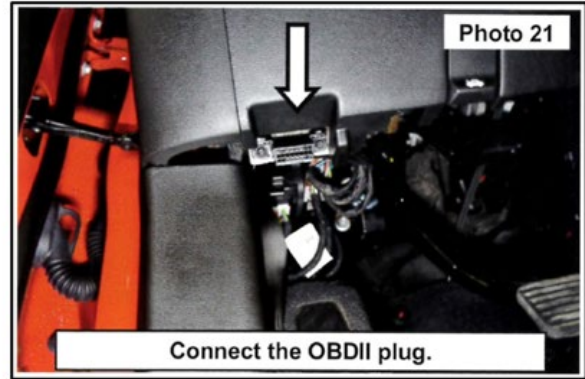
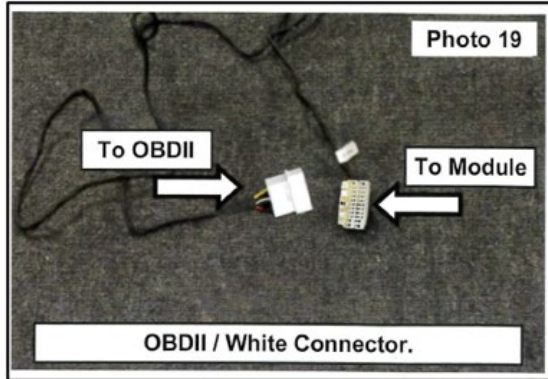

39. The Accused Products include a controller in electronic communication with the motor. Upon information and belief, the controller is configured, in response to the data received from the already existing electronics port, to cause the motor to effectuate movement of the stepping member between the retracted position and the deployed position (see **Exhibits F and G** (“step control module” shown in Photo 13)).

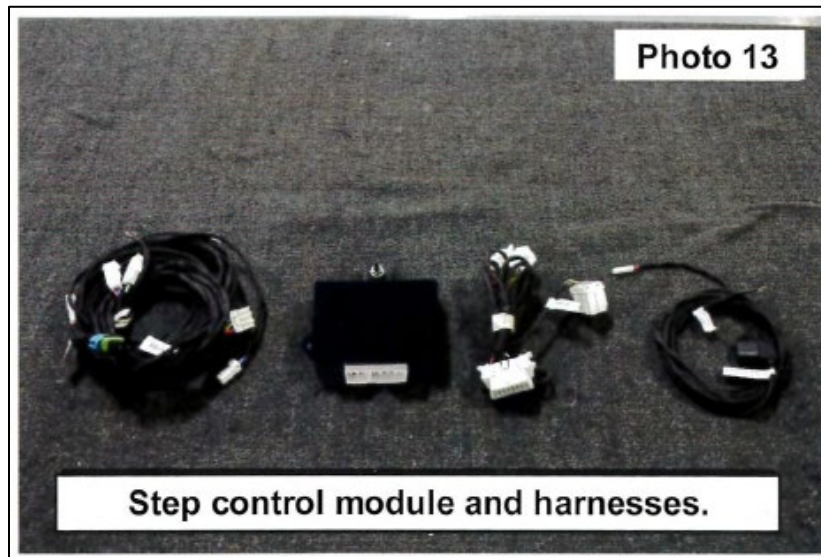

40. The data to be received by the Accused Products comprises door opened/closed status information originating from door electronics that do not incorporate any wireless sensors to detect door opened/closed status. Upon information and belief, in the relevant vehicles, including at least the 2020 Sierra and Silverado model vehicles, the door opened/closed status

originates from wired door electronics using a wired circuit and latching mechanism (see, e.g., for the 2020 Silverado 1500 model, pages 2-73 through 2-76 of https://www.gmupfitter.com/wp-content/uploads/2022/09/20_Silverado_1500_Electrical_Body_Builder_2019JUN21.pdf).

41. Upon information and belief, Rough Country has actively induced others to infringe the '667 Patent by marketing, offering for sale, and selling the Accused Products, knowing and intending that such retractable step products would be used by customers and end users in a manner that infringes the '667 Patent. To that end, Rough Country provides instructions and information to its customers and the end users, encouraging use of the retractable step products in a manner that infringes the '667 Patent (see, e.g., **Exhibit G**). These acts by Rough Country constitute infringement of the '667 Patent in violation of at least 35 U.S.C. § 271(b).

42. Upon information and belief, the acts of Rough Country constitute contributory infringement of the '667 Patent in violation of 35 U.S.C. § 271(c). Upon information and belief, Rough Country contributorily infringes because, among other things, Rough Country offers to sell and/or sells within the United States, and/or imports into the United States, retractable step products that constitute material parts of the invention of the asserted claims of the '667 Patent, that are not staple articles or commodities of commerce suitable for substantial non-infringing use, and that are known by Rough Country to be especially made or especially adapted for use in an infringement of the '667 Patent.

43. Upon information and belief, the infringement of the '667 Patent by Rough Country has been, and continues to be, willful, deliberate, and intentional by continuing its acts of infringement after becoming aware of the '667 Patent and its infringement thereof, thus acting in reckless disregard of the patent rights of Lund.

44. As a consequence of the infringement of the '667 Patent, Lund has suffered and will continue to suffer irreparable harm and injury, including monetary damages in an amount to be determined at trial.

45. Upon information and belief, unless enjoined, Rough Country and/or others acting on its behalf, will continue their infringing acts relating to the '667 Patent, thereby causing additional irreparable injury to Lund for which there is no adequate remedy at law.

SECOND CLAIM FOR RELIEF:

INFRINGEMENT OF THE '449 PATENT

46. Lund repeats, realleges and reincorporates by reference the allegations set forth in paragraphs 1 through 45.

47. Upon information and belief, the Accused Products infringe at least Claim 12 of the '449 patent under 35 U.S.C. § 271(a) either literally or under the doctrine of equivalents.

48. Upon information and belief, Rough Country has directly infringed one or more of the claims of the '449 patent through the manufacture, use, offering for sale, and/or selling within the United States, and/or importation into the United States, of retractable step products including the Accused Products in violation of 35 U.S.C. § 271(a).

49. For example, the Accused Products, including the “Retract Step Kit Lighted | Crew Cab | Chevy/GMC 1500/2500HD (19-22),” include all of the limitations of Claim 12 of the '449 patent.

50. The Accused Products include a powered vehicle step system configured for use with a vehicle system (see **Exhibit F**).

51. The Accused Products include a stepping deck (see **Exhibit F**).



52. The Accused Products include a motor drivably coupled to the stepping deck (see **Exhibit F** (“These durable electric side steps feature a motorized ‘swing-out’ function that instantly extends the step when you open the door.”)).

53. The Accused Products include a controller (see e.g. photo 13 of the “step control module” in **Exhibit G**).

54. Upon information and belief, the controller of the Accused Products is configured to receive door status information electronically obtained from a digital communication bus of the vehicle, namely the On-Board Diagnostic (“OBDII”) port (see **Exhibit F** (“Rough Country’s retractable truck steps ... connect[] directly to your battery terminal and OBDII port.”) and **Exhibit G** (steps 20-25 explaining connecting the control module to the OBDII port)).

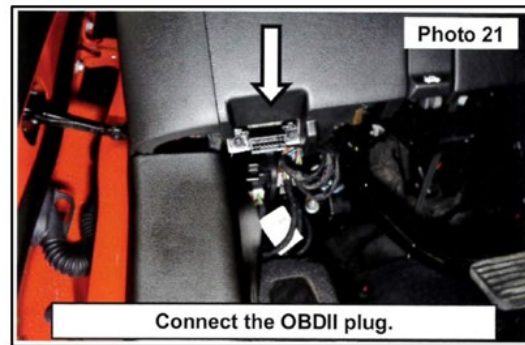
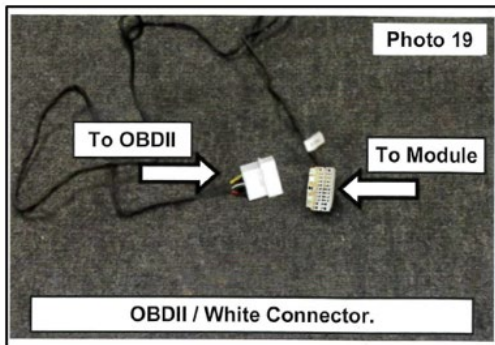

55. The controller of the Accused Products is configured to electronically process the door status information according to an algorithm to determine that movement of the stepping deck is appropriate (see **Exhibit F** (“These durable electric side steps feature a motorized ‘swing-out’

function that instantly extends the step when you open the door. ... Once the door closes, the step automatically tucks away for a clean look.”)).

56. The controller of the Accused Products is configured to command the motor to cause movement of the stepping deck between a retracted position and a deployed position (see **Exhibits F and G** (explaining the connection of the electronics including the control module and motors)).

57. The Accused Products are configured to electronically obtain the door status information via a plug-in connection to the digital communication bus (see **Exhibit F** (“Rough Country’s retractable truck steps ... connect[] directly to your battery terminal and OBDII port.”)).

58. Upon information and belief, Rough Country has actively induced others to infringe the ’449 Patent by marketing, offering for sale, and selling the Accused Products, knowing and intending that such retractable step products would be used by customers and end users in a manner that infringes the ’449 Patent. To that end, Rough Country provides instructions and information to its customers and the end users , encouraging use of the retractable step products in a manner that infringes the ’449 Patent (see, e.g., **Exhibit G**). These acts by Rough Country constitute infringement of the ’449 Patent in violation of at least 35 U.S.C. § 271(b).

59. Upon information and belief, the acts of Rough Country constitute contributory infringement of the ’449 Patent in violation of 35 U.S.C. § 271(c). Upon information and belief, Rough Country contributorily infringes because, among other things, Rough Country offers to sell and/or sells within the United States, and/or imports into the United States, retractable step products that constitute material parts of the invention of the asserted claims of the ’449 Patent, that are not staple articles or commodities of commerce suitable for substantial non-infringing use,

and that are known by Rough Country to be especially made or especially adapted for use in an infringement of the '449 Patent.

60. Upon information and belief, the infringement of the '449 Patent by Rough Country has been, and continues to be, willful, deliberate, and intentional by continuing its acts of infringement after becoming aware of the '449 Patent and its infringement thereof, thus acting in reckless disregard of the patent rights of Lund.

61. As a consequence of the infringement of the '449 Patent, Lund has suffered and will continue to suffer irreparable harm and injury, including monetary damages in an amount to be determined at trial.

62. Upon information and belief, unless enjoined, Rough Country and/or others acting on its behalf, will continue their infringing acts relating to the '449 Patent, thereby causing additional irreparable injury to Lund for which there is no adequate remedy at law.

THIRD CLAIM FOR RELIEF:

INFRINGEMENT OF THE '717 PATENT

63. Lund repeats, realleges and reincorporates by reference the allegations set forth in paragraphs 1 through 62.

64. Upon information and belief, the Accused Products infringe at least Claim 9 of the '717 patent under 35 U.S.C. § 271(a) either literally or under the doctrine of equivalents.

65. Upon information and belief, Rough Country has directly infringed one or more of the claims of the '717 patent through the manufacture, use, offering for sale, and/or selling within the United States, and/or importation into the United States, of retractable step products including the Accused Products in violation of 35 U.S.C. § 271(a).

66. For example, the Accused Products, including the “Retract Step Kit Lighted | Crew Cab | Chevy/GMC 1500/2500HD (19-22),” include all of the limitations of Claim 9 of the ’717 patent.

67. The Accused Products include a vehicle step assist system configured for use with a vehicle (see **Exhibit F**).

68. The Accused Products include a step unit comprising a stepping deck and configured for mounting to a vehicle (see **Exhibit F**).



69. The Accused Products include a vehicle interface configured to connect with an already existing electronics port of the vehicle, namely the OBDII. The vehicle interface is configured to electronically receive data via the existing electronics port, the data generated by existing electronics of the vehicle. See **Exhibit F** (“Rough Country’s retractable truck steps ... connect[] directly to your battery terminal and OBDII port.”)

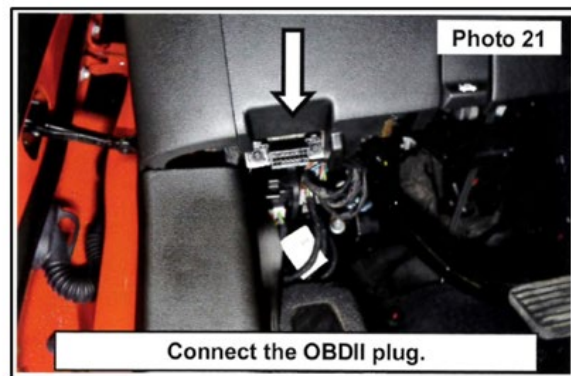
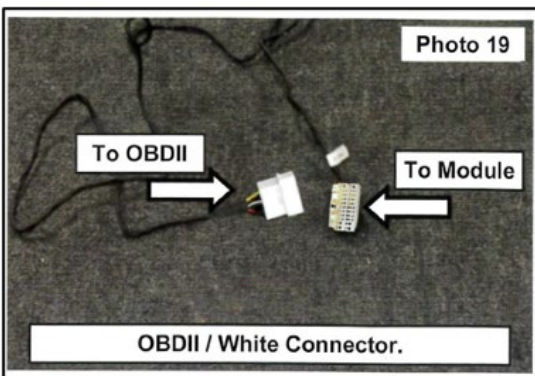

70. The Accused Products include a controller in electronic communication with the vehicle interface and with the step unit (see **Exhibit G** (steps 20-25 explaining connecting the control module to the OBDII port)). Upon information and belief, the controller is configured, in response to the data received from the already existing electronics port, to issue commands to the step unit to perform one or more operations associated with the step unit (see **Exhibits F and G**).

71. Upon information and belief, Rough Country has actively induced others to infringe the '717 Patent by marketing, offering for sale, and selling the Accused Products, knowing and intending that such retractable step products would be used by customers and end users in a manner that infringes the '717 Patent. To that end, Rough Country provides instructions and information to its customers and the end users, encouraging use of the retractable step products in a manner that infringes the '717 Patent (see, e.g., **Exhibit G**). These acts by Rough Country constitute infringement of the '717 Patent in violation of at least 35 U.S.C. § 271(b).

72. Upon information and belief, the acts of Rough Country constitute contributory infringement of the '717 Patent in violation of 35 U.S.C. § 271(c). Upon information and belief, Rough Country contributorily infringes because, among other things, Rough Country offers to sell and/or sells within the United States, and/or imports into the United States, retractable step products that constitute material parts of the invention of the asserted claims of the '717 Patent, that are not staple articles or commodities of commerce suitable for substantial non-infringing use, and that are known by Rough Country to be especially made or especially adapted for use in an infringement of the '717 Patent.

73. Upon information and belief, the infringement of the '717 Patent by Rough Country has been, and continues to be, willful, deliberate, and intentional by continuing its acts of

infringement after becoming aware of the '717 Patent and its infringement thereof, thus acting in reckless disregard of the patent rights of Lund.

74. As a consequence of the infringement of the '717 Patent, Lund has suffered and will continue to suffer irreparable harm and injury, including monetary damages in an amount to be determined at trial.

75. Upon information and belief, unless enjoined, Rough Country and/or others acting on its behalf, will continue their infringing acts relating to the '717 Patent, thereby causing additional irreparable injury to Lund for which there is no adequate remedy at law.

FOURTH CLAIM FOR RELIEF:

INFRINGEMENT OF THE '395 PATENT

76. Lund repeats, realleges and reincorporates by reference the allegations set forth in paragraphs 1 through 75.

77. Upon information and belief, the Accused Products infringe at least Claim 1 of the '395 patent under 35 U.S.C. § 271(a) either literally or under the doctrine of equivalents.

78. Upon information and belief, Rough Country has directly infringed one or more of the claims of the '395 patent through the manufacture, use, offering for sale, and/or selling within the United States, and/or importation into the United States, of retractable step products including the Accused Products in violation of 35 U.S.C. § 271(a).

79. For example, the Accused Products, including the “Retract Step Kit Lighted | Crew Cab | Chevy/GMC 1500/2500HD (19-22),” include all of the limitations of Claim 1 of the '395 patent.

80. The Accused Products include a powered retractable vehicle step assist system configured for use with a vehicle (see **Exhibit F**).

81. The Accused Products include a stepping member having a stepping surface and movable between a retracted position and a deployed position with respect to the vehicle. The stepping member is outboard of the retracted position when in the deployed position (see **Exhibit F** (“These durable electric side steps feature a motorized ‘swing-out’ function that instantly extends the step when you open the door. ... Once the door closes, the step automatically tucks away for a clean look.”)).



82. The stepping member of the Accused Products is dimensioned to span a length so as to assist passengers with entering and exiting first and second doors of the vehicle (see **Exhibit F** (stating compatibility with “4-Door Crew Cab models”) and **Exhibit G**).

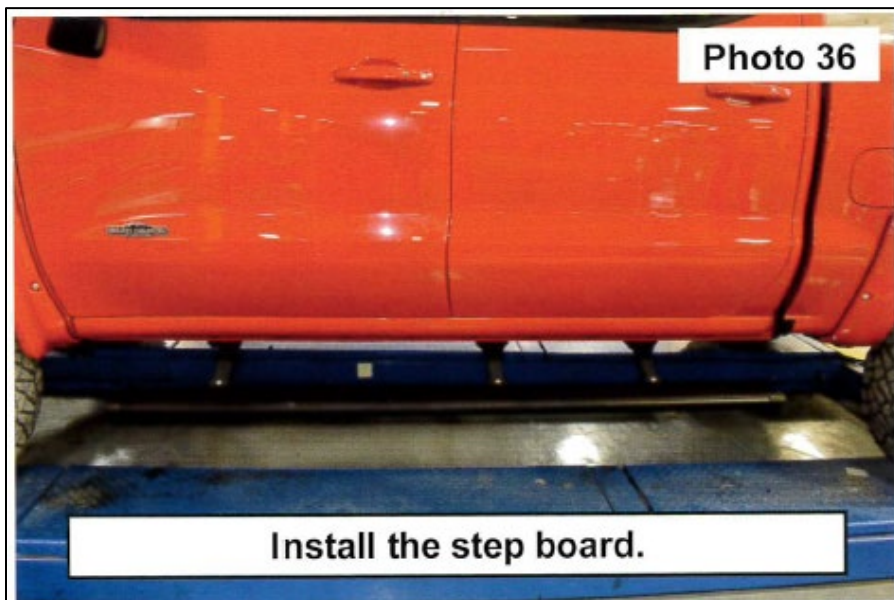

83. The Accused Products include first and second support members connectable with respect to an underside of the vehicle and connected to the stepping member. The support members are configured to at least partially support the stepping member beneath the first and second doors of the vehicle (see **Exhibits F and G**).

84. The first and second support members of the Accused Products each comprise at least a first support arm and a support bracket (see **Exhibit G**). The first support arm is connectable with respect to the underside of the vehicle so as to be pivotable about at least a first axis. The support bracket is rigidly connected to the stepping member and connected to the first support arm to be pivotable about at least a second axis.



85. The Accused Products include a drive unit, namely a motor, operably coupled to the first support member and capable of effectuating movement of the stepping member between the retracted position and the deployed position (see **Exhibit F** (“These durable electric side steps feature a motorized ‘swing-out’ function that instantly extends the step when you open the door. ... Once the door closes, the step automatically tucks away for a clean look.”) and **Exhibit G** (“1. Locate the Left side step brackets ... [s]hown with idler arm and motor.”)).

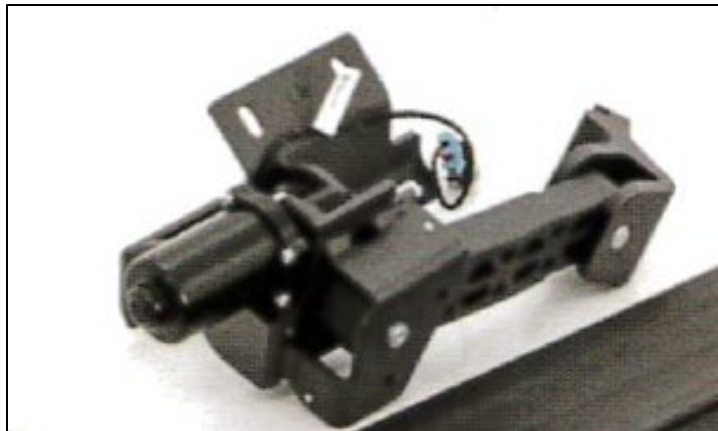

86. Upon information and belief, the Accused Products include a vehicle interface configured to electronically receive data generated by an existing computer system of the vehicle (see **Exhibits F and G**).

87. The Accused Products include a controller in electronic communication with the vehicle interface and the drive unit (see **Exhibit G** (explaining the electrical connection between the control module, the OBDII plug, and the motors)). Upon information and belief, said controller is configured to cause the drive unit to effectuate movement of the stepping member from the retracted position to the deployed position, in response to the data received from the existing computer system of the vehicle (see **Exhibits F and G**).

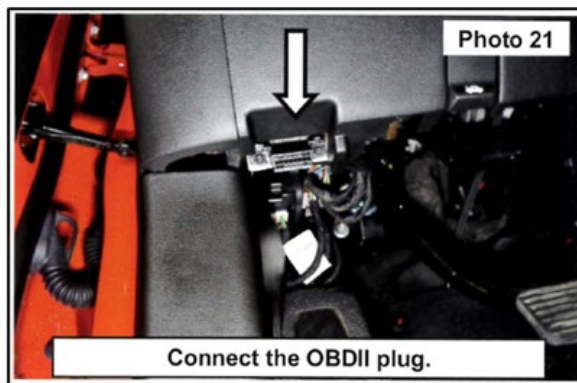
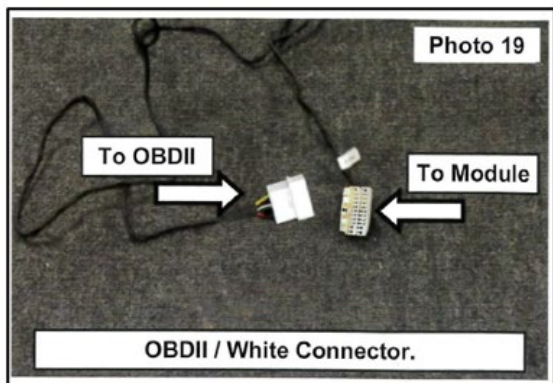

88. The data received from the existing computer system of the vehicle of the Accused Products comprises door status information indicating that the first door or the second door is

opened. Upon information and belief, the door status information of the Accused Products originates from door electronics that do not incorporate any wireless sensors to detect whether the door is opened in response to user actuation of a door handle. Upon information and belief, in the relevant vehicles, including at least the 2020 Sierra and Silverado model vehicles, the door opened/closed status originates from wired door electronics using a wired circuit and latching mechanism, including both front and rear door latch assemblies (see, e.g., for the 2020 Silverado 1500 model, pages 2-73 through 2-76 of https://www.gmupfitter.com/wp-content/uploads/2022/09/20_Silverado_1500_Electrical_Body_Builder_2019JUN21.pdf).

89. Upon information and belief, Rough Country has actively induced others to infringe the '395 Patent by marketing, offering for sale, and selling the Accused Products, knowing and intending that such retractable step products would be used by customers and end users in a manner that infringes the '395 Patent. To that end, Rough Country provides instructions and information to its customers and the end users, encouraging use of the retractable step products in a manner that infringes the '395 Patent (see, e.g., **Exhibit G**). These acts by Rough Country constitute infringement of the '395 Patent in violation of at least 35 U.S.C. § 271(b).

90. Upon information and belief, the acts of Rough Country constitute contributory infringement of the '395 Patent in violation of 35 U.S.C. § 271(c). Upon information and belief, Rough Country contributorily infringes because, among other things, Rough Country offers to sell and/or sells within the United States, and/or imports into the United States, retractable step products that constitute material parts of the invention of the asserted claims of the '395 Patent, that are not staple articles or commodities of commerce suitable for substantial non-infringing use, and that are known by Rough Country to be especially made or especially adapted for use in an infringement of the '395 Patent.

91. Upon information and belief, the infringement of the '395 Patent by Rough Country has been, and continues to be, willful, deliberate, and intentional by continuing its acts of infringement after becoming aware of the '395 Patent and its infringement thereof, thus acting in reckless disregard of the patent rights of Lund.

92. As a consequence of the infringement of the '395 Patent, Lund has suffered and will continue to suffer irreparable harm and injury, including monetary damages in an amount to be determined at trial.

93. Upon information and belief, unless enjoined, Rough Country and/or others acting on its behalf, will continue their infringing acts relating to the '395 Patent, thereby causing additional irreparable injury to Lund for which there is no adequate remedy at law.

PRAYER FOR RELIEF

WHEREFORE, Plaintiff Lund prays for judgment and seeks relief as follows:

A. Pursuant to 35 U.S.C. § 271, a determination that Rough Country and its officers, agents, servants, employees, dealers, retailers, distributors, manufacturers, and all others in active concert and/or participation with Rough Country have infringed each of the '667, '449, '717, and '395 Patents.

B. Pursuant to 35 U.S.C. § 284, an award of monetary damages compensating Lund for Rough Country's infringement of the '667, '449, '717, and '395 Patents.

C. Pursuant to 35 U.S.C. § 284, an award increasing monetary damages up to three times the amount found or assessed by the jury for Rough Country's infringement of the '667, '449, '717, and '395 Patents in view of the willful and deliberate nature of the infringement.

D. Pursuant to 35 U.S.C. § 285, a finding that this is an exceptional case, and an award of reasonable attorney's fees and non-taxable costs.

E. Pursuant to 35 U.S.C. § 284, an assessment of prejudgment and post-judgment interest and costs against Rough Country, together with an award of such interests and costs.

F. Pursuant to 35 U.S.C. § 283, an injunction enjoining Rough Country and its officers, agents, servants, employees, dealers, retailers, distributors, manufacturers, and all others in active concert and/or participation with Rough Country from infringing any and all of the '667, '449, '717, and '395 Patents through the manufacture, importation, use, offer for sale, and/or sale of infringing products, and/or any of the other acts prohibited by 35 U.S.C. § 271.

G. An order requiring Rough Country to account to Lund for any and all profits derived by Rough Country or its subsidiaries and all damages sustained by Lund by virtue of Rough Country's infringing activities.

H. Such other and further relief as this Court deems equitable and just under the circumstances.

Respectfully submitted,

/s/ Karen E. Keller

Karen E. Keller (No. 4489)

Nathan R. Hoeschen (No. 6232)

Emily S. DiBenedetto (No. 6779)

SHAW KELLER LLP

I.M. Pei Building

1105 North Market Street, 12th Floor

Wilmington, DE 19801

(302) 298-0700

kkeller@shawkeller.com

nhoeschen@shawkeller.com

edibenedetto@shawkeller.com

Attorneys for Plaintiff

OF COUNSEL:

Jon W. Gurka

Ben J. Everton

KNOBBE, MARTENS, OLSON & BEAR, LLP

2040 Main Street, Fourteenth Floor

Irvine, California 92614

(949) 760-0404

Dated: October 28, 2022