

**IN THE UNITED STATES DISTRICT COURT
FOR THE EASTERN DISTRICT OF MISSOURI**

HANDI-CRAFT COMPANY,)	
)	
Plaintiff,)	Case No. _____
)	
vs.)	
)	
)	JURY TRIAL DEMANDED
S.C. PRODUCTS, INC. & MICHAEL)	
L. MCGINLEY,)	
)	
Defendants.)	

COMPLAINT

1. Plaintiff Handi-Craft Company, by and through its attorneys, for its Complaint against Defendants S.C. Products, Inc. and Michael L. McGinley (collectively “Defendants”), alleges as follows:

NATURE OF THE ACTION

2. This is an action for a declaratory judgment of non-infringement and invalidity of United States Patent No. 8,636,178 arising under the Declaratory Judgment Act, 28 U.S.C. §§ 2201 and 2202, and the patent laws of the United States, including Title 35, United States Code; for tortious interference under the laws of the State of Missouri; and for unfair competition under the laws of the State of Missouri.

PARTIES

3. Plaintiff Handi-Craft Company (“Handi-Craft”) is a Missouri Corporation with a principal place of business at 4433 Fyler Ave, St. Louis, MO 63116. Handi-Craft is an industry-

leading manufacturer and distributor known for its Dr. Brown's baby bottles and baby and caregiver products.

4. On information and belief, Defendant S.C. Products, Inc. ("SCP") is a Missouri Corporation located at 5845 Horton Street, Suite 212, Mission, Kansas, 66208.

5. On information and belief, Defendant Michael L. McGinley ("McGinley") is an individual who resides in Prairie Village, Kansas, and is an officer, director, and controls SCP as its President, Secretary, and Director.

JURISDICTION AND VENUE

6. This Court has original jurisdiction over the subject matter of this action under 28 U.S.C. §§ 1331, 1338, 1367, 2201, and 2202.

7. This Court has personal jurisdiction over McGinley in this District pursuant to Mo. Rev. Stat. § 506.500 because, on information and belief, McGinley has a continuous and systematic presence in, and/or contacts with, the state of Missouri, has individually and/or through one or more duly authorized agents or licensees, conducted and transacted business within this state (including related to enforcement of the patent at issue in this case), and has commissioned tortious acts within this state.

8. This Court has personal jurisdiction over SCP in this District because it is incorporated and exists under the laws of the State of Missouri.

9. Venue is proper in this District under 28 U.S.C. § 1391(b) because Defendants are subject to personal jurisdiction in this District, and a substantial part of the events giving rise to the claims, including the ongoing harm resulting from Defendants' actions, occurred in this District.

ALLEGATIONS COMMON TO ALL CLAIMS

U.S. Patent No. 8,636,178

10. On January 28, 2014, the United States Patent and Trademark Office (“USPTO”) issued United States Patent No. 8,636,178 (“the ‘178 Patent”), entitled “FLEXIBLE PANEL PITCHER,” to Defendant McGinley and Brian Lau.

11. A true and accurate copy of the ‘178 Patent is attached as Exhibit 1.

12. On information and belief, before the ‘178 Patent issued, Brian Lau, for good and valuable consideration, voluntarily sold, assigned, transferred and conveyed to McGinley, among other things, all of his right, title, and interest in and to the flexible panel pitcher invention and what became the ‘178 Patent pursuant to a written assignment agreement.

13. On information and belief, McGinley has owned the ‘178 Patent since June 28, 2014.

14. On information and belief, SCP holds, and at all relevant times has held, an exclusive license from McGinley to sell products covered by the ‘178 Patent.

Amazon.com Inc’s. Notice of Infringement Procedures

15. Amazon.com, Inc. (“Amazon”), is a multinational company that provides, among other things, ecommerce, order fulfillment, and shipping services to third parties selling various products on Amazon’s ecommerce platform located at Amazon.com.

16. Among its many policies applicable to sellers and buyers on its ecommerce platform, Amazon provides mechanisms for intellectual property owners to allege infringement of their intellectual property rights by Sellers on Amazon’s platform.

17. Amazon will remove any product or content alleged to infringe the patent rights of a party and take further action Amazon deems appropriate if (1) the patent owner submits a

notice of infringement; (2) the notice is valid, detailing the requested information; and (3) the notice is accepted.¹

18. To submit a notice of infringement to Amazon, the owner of the intellectual property rights in dispute, or its agent, is required to complete a “Report Infringement Form.”

19. Under the form, a rights holder is only required to submit the following information:

Allegation of Infringement

Are you the Rights Owner or an Agent?
 Rights Owner Agent

The primary complaint pertains to
patent concerns

The specific concern is
utility patent

Name of Brand

Patent Number

Do you have a court order or ITC (International Trade Commission) order regarding enforcement of this Patent?
 Yes - Court Order Yes - ITC No

Additional Information

1000

The ASIN (Amazon Standard Identification Number) or the URL of each product you are reporting. You can report up to 50 products for the same specific concern in 1 form. If you have different concerns to report, please submit 1 form for each concern.

ASIN/ISBN-10 -OR- Product URL

2

20. To submit the “Report Infringement” form, the rights holder must read and accept the following representations: (1) “I have a good faith belief that the content(s) described above violate(s) my rights described above or those held by the rights owner, and that the use of such content(s) is contrary to law[;]” (2) “I declare, under penalty of perjury, that the information contained in this notification is correct and accurate and that I am the owner or agent of the owner of the rights described above[;]” and (3) “I understand that, if accepted, the information

¹ See <https://sellercentral.amazon.com/help/hub/reference/external/U5SQCEKADDAQRLZ> (last visited January 19, 2023).

² <https://www.amazon.com/report/infringement> (last visited January 19, 2023).

included in this report may be shared by Amazon with all the reported sellers, with the exception of any order ID number(s).”³

21. On information and belief, Amazon does not try to confirm whether an infringement allegation is correct or made in bad faith. Upon acceptance of a valid allegation that a seller is infringing the intellectual property rights of another, Amazon notifies the allegedly infringing seller and indefinitely suspends sales of the allegedly infringing product.

22. Under Amazon’s policies and practices, only the rights owner or its agent may withdraw the complaint of infringement against the alleged infringer.

23. Under Amazon’s policies and practices, if the rights owner or its agent does not withdraw the notice of infringement, the accused seller’s only recourse is (1) to contact the party reporting infringement to negotiate a resolution in which the accusing party retracts its allegation of infringement, and thus allowing sales of the accused product, or (2) commence litigation.

24. On information and belief, without a court order or a resolution between the parties, Amazon generally will not resume sales of the accused product on its platform.

Handi-Craft’s Dino-Pour Bath Rinse Cup

25. Since 1963, Handi-Craft has invented, manufactured, and commercialized innovative, high quality attractive products for babies and small children commonly under the tradename “Dr. Brown’s.”

26. Based on its innovative and high-quality products, Handi-Craft is known as one of the leading baby product companies in the world.

³ <https://www.amazon.com/report/infringement> (last visited January 19, 2023).

27. Handi-Craft products are sold in the United States by major retailers, both brick-and-mortar and online, such as Amazon and Wal-Mart. Handi-Craft’s online presence enjoys a good reputation with its consumers.

28. In October 2022, Handi-Craft began to sell new, high quality rinse cups on Amazon under its Dr. Brown’s tradename (the “Dino-Pour Bath Rinse Cup”). An image of this product is shown below:



29. Based on the Dino-Pour Bath Rinse Cup’s sales performance, Handi-Craft expected strong sales on Amazon, including during the December 2022 holiday season.

30. Due to Defendants’ improper infringement allegations, however, Handi-Craft’s sales of the Dino-Pour Bath Rinse Cup on Amazon were abruptly discontinued in December of 2022—in the middle of the holiday shopping season.

Defendants’ Improper Infringement Allegations Made to Amazon

31. On information and belief, on or before December 8, 2022, Defendants’ agent Erin McGinley submitted a complaint to Amazon alleging that Handi-Craft’s Dino-Pour Bath

Rinse Cup (ASIN: B0BHZWRY8W) infringes the '178 Patent (Amazon Complaint ID: 11466145841, hereinafter "Amazon Complaint").

32. On information and belief, Defendants submitted the Amazon Complaint in bad faith, knowing that Handi-Craft's Dino-Pour Bath Rinse Cup does not infringe the '178 Patent.

33. SCP sells its own shampoo rinse cup on Amazon.⁴

34. SCP's rinse cup competes with Handi-Craft's Dino-Pour Bath Rinse Cup.

35. On information and belief, Defendants submitted the Amazon Complaint with the improper intent to prevent Handi-Craft from selling a competing product to SCP's shampoo rinse cup sold on Amazon.

36. After receiving Defendants' Amazon Complaint, Amazon suspended sales of the Dino-Pour Bath Rinse Cup on its platform on or about December 8, 2022, thereby precluding customers from buying the Dino-Pour Bath Rinse Cup and resulting in a significant loss of sales revenue by Handi-Craft.

37. On multiple occasions, Handi-Craft communicated with Amazon requesting that the suspension be lifted and the ASIN for the Dino-Pour Bath Rinse Cup be re-activated, but Amazon refused to do so unless SCP agreed to retract the Amazon Complaint.

38. Amazon did not consider or evaluate the merits of Defendants' infringement allegations in the Amazon Complaint.

39. On December 15, 2022, Handi-Craft sent a letter to SCP by both email and certified mail explaining in detail why the Amazon Complaint filed by SCP was improper and requesting SCP to retract it.

⁴ See <https://www.amazon.com/SC-Products-Shampoo-Rinse-Cup/dp/B007XL648Q> (last visited January 18, 2023).

40. Despite follow-up communications, SCP has never responded to Handi-Craft's letter and has refused to retract the Amazon Complaint.

Defendants' Bad Faith

41. On information and belief, once Defendants learned about Handi-Craft's Dino-Pour Bath Rinse Cup being sold on Amazon, Defendants engaged in a scheme to unlawfully and unfairly compete with Handi-Craft in the sale of rinse cups.

42. On information and belief, Defendants knew that the infringement allegation in their Amazon Complaint would not be substantively scrutinized by Amazon, and would result in Handi-Craft's Dino-Pour Bath Rinse Cup being removed from Amazon's platform, thus eliminating direct competition to SCP's shampoo rinse cup during the critical holiday sales season as well as for the foreseeable future.

43. On information and belief, Defendants sent the Amazon Complaint knowing that the infringement allegation was false or with disregard of the truth or falsity of the allegation.

44. Defendants were involved in the effort to file patent applications and secure patent protection for the flexible panel pitcher developed by McGinley.

45. During prosecution of these patent applications, McGinley had to narrow the scope of the claims by adding certain claim limitations that are missing from Handi-Craft's Dino-Pour Rinse Cup.

46. For example, on June 30, 2006, the USPTO rejected the claims in one of McGinley's earlier related patent applications as invalid under 35 U.S.C. §§ 102 and 103 based on U.S. Patent No. 4,756,439 ("Perock reference"). *See* Exhibit 2 (Prosecution History for U.S. Patent No. 7,441,675, to which the '178 Patent claims priority), at 4–5.

47. The USPTO based its rejection on the fact that the prior-art Perock reference discloses a “container having a flexible panel area 17 that is designed to [be] flexible and is covering a least a portion of the side panel.” *Id.* at 4. This flexible panel area is shown, for example in Figure 1 of the Perock reference (attached as Exhibit 3):

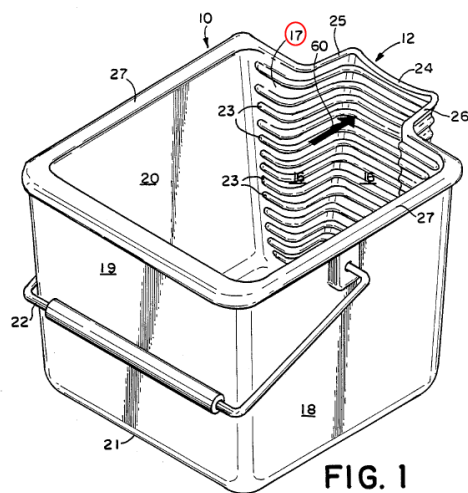

48. In response to the USPTO’s rejection, McGinley amended claim 1 to require, among other things, that the flexible panel have “a generally smooth inward surface for unobstructed fluid flow.” Ex. 2, at 8–9, 11–13. McGinley asserted that the prior art cited by the USPTO has “corrugations . . . on [a] wall 17 which would obstruct the flow of fluid out of the container” and, therefore, did not satisfy the requirement that the flexible panel have “a generally smooth inward surface for unobstructed flow,” as required by the amendments to the claims. Ex. 2 at 8.

49. During prosecution of the patent application that issued as the ‘178 Patent, McGinley again included this claim limitation that was necessary to distinguish the prior art, requiring a “flexible panel having a generally smooth inward surface for unobstructed fluid flow.” This limitation is a requirement of every claim of the ‘178 Patent.

50. Defendants knew that during prosecution of his patent applications McGinley expressly excluded containers that have corrugations on the inward surface of the flexible panel.

51. The flexible panel of Handi-Craft's Dino-Pour Bath Rinse Cup has a corrugated inward surface, which is readily apparent from photographs of the product, as seen below:



52. The corrugated inward surface of Handi-Craft's Dino-Pour Bath Rinse Cup were visible to Defendants in the photographs of this product on the Amazon listing against which Defendants filed the Amazon Complaint.

53. On information and belief, at the time Defendants filed the Amazon Complaint, each Defendant knew that Handi-Craft's Dino-Pour Bath Rinse Cup's flexible panel had a corrugated surface and did not have a "generally smooth inward surface for unobstructed fluid flow."

54. Absent a declaration of non-infringement or invalidity, Defendants will continue to wrongfully allege that Handi-Craft's Dino-Pour Bath Rinse Cup infringes the '178 Patent, and thereby cause Handi-Craft irreparable injury and damage.

COUNT I: DECLARATORY JUDGMENT OF NON-INFRINGEMENT

55. Handi-Craft realleges and incorporates by reference the preceding allegations of the Complaint, as if fully set forth herein.

56. There exists a substantial, immediate, and real controversy between Handi-Craft and Defendants sufficient to warrant the issuance of a declaratory judgment of non-infringement with respect to the '178 Patent.

57. There is an actual controversy within the jurisdiction of this Court under 28 U.S.C. §§ 2201 and 2202.

58. Handi-Craft does not directly or indirectly infringe the '178 Patent either literally or under the doctrine of equivalents, through the manufacture, importation, use, sale, and/or offer for sale of the Dino-Pour Bath Rinse Cup.

59. For example, the inwardly flexible panel of the Dino-Pour Bath Rinse Cup does not have “a generally smooth inward surface for unobstructed fluid flow out of [the] open upper sidewall end,” as required by all of the claims the '178 Patent.

60. Instead, the Dino-Pour Bath Rinse Cup's inwardly flexible panel's inward surface has numerous corrugations. As illustrated below, these features render the inward surface of the container not “generally smooth” and obstruct fluid flow out of the open upper sidewall end:

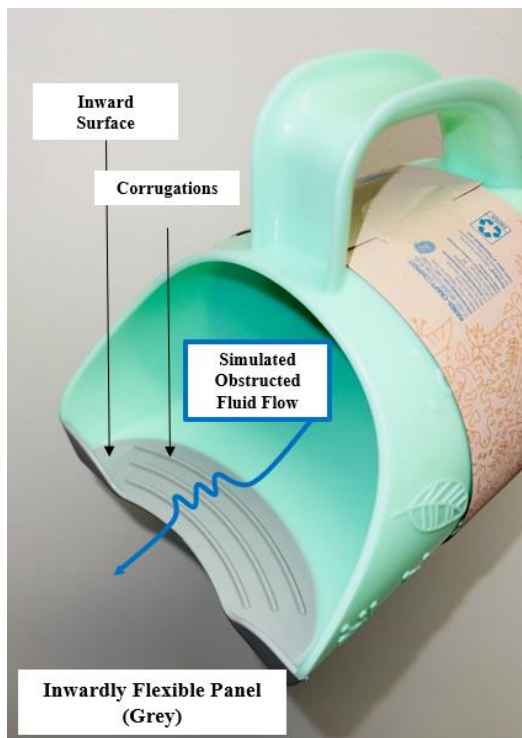

61. For at least these reasons, Handi-Craft's Dino-Pour Bath Rinse Cup does not infringe the '178 Patent.

COUNT II: DECLARATORY JUDGMENT OF INVALIDITY

62. Handi-Craft realleges and incorporates by reference the preceding allegations of the Complaint, as if fully set forth herein.

63. As a result of the acts described in the preceding paragraphs, there exists a controversy of sufficient immediacy to warrant the issuance of a declaratory judgment of invalidity with respect to the '178 Patent.

64. The '178 Patent is invalid under one or more of 35 U.S.C. §§ 102, 103, and/or 112.

65. For example, the claims of the '178 Patent are anticipated and/or rendered obvious by U.K. Patent No. 2,269,811, Swiss Patent No. 274,789, and/or U.S. Patent No. 2,610,490.

COUNT III: TORTIOUS INTERFERENCE WITH BUSINESS EXPECTANCY
(Missouri Common Law)

66. Handi-Craft realleges and incorporates by reference the preceding allegations of the Complaint, as if fully set forth herein.

67. At all relevant times, Handi-Craft possessed a valid a business expectancy with Amazon and customers using the Amazon website on which Handi-Craft products were offered for sale.

68. On information and belief, Defendants knew that Handi-Craft had a relationship with Amazon and customers using the Amazon website as an established seller on Amazon.

69. Around early December 2022, Defendants pursued bad faith allegations that the Dino-Pour Bath Rinse Cup infringed the '178 Patent in the Amazon Complaint.

70. Defendants submitted the Amazon Complaint without justification and with the intent to prevent sales of the Dino-Pour Bath Rinse Cup by Handi-Craft to Amazon customers.

71. As a direct result of Defendants' improper Amazon Complaint, Handi-Craft is no longer able to sell the Dino-Pour Bath Rinse Cup on Amazon's website, and has suffered significant damages.

72. By its conduct, Defendants tortiously and in bad-faith intentionally interfered with Handi-Craft's legitimate business expectations and relationships with Amazon and customers using Amazon's website.

73. Handi-Craft has been harmed and will continue to be harmed by Defendants' tortious actions.

74. Defendants' acts of interference complained of herein have proximately caused harm to Handi-Craft in an amount to be proven at trial, in a manner and amount that cannot be fully measured or compensated in economic terms, and for which there is no adequate remedy at

law. The actions of the Defendants have damaged, and will continue to damage, Handi-Craft's business, market, reputation, and goodwill, and such irreparable damage will continue unless Defendants' acts are enjoined during the pendency of this action and thereafter.

75. Defendants' actions in submitting a false infringement allegation to suppress sales of a competitive product were done willfully and/or with reckless disregard of the consequences of these actions.

COUNT IV: UNFAIR COMPETITION
(Missouri Common Law)

76. Handi-Craft realleges and incorporates by reference the preceding allegations of the Complaint, as if fully set forth herein.

77. Defendants' acts complained of herein constitute an unfair trade practices that harm Handi-Craft, including and without limitation, the submission of knowingly false statements and misleading information to Amazon concerning alleged infringement of the '178 Patent through Amazon's report infringement form, with the intent and purpose to suspend sales of the competitive Dino-Pour Bath Rinse Cup and hinder Handi-Craft's ability to operate on Amazon's website to gain a competitive advantage, while having the knowledge that Amazon would not reinstate Handi-Craft's Dino-Pour Bath Rinse Cup unless Defendants decided to retract the infringement notice submission.

78. Defendants' unfair competition has caused harm to Handi-Craft in an amount to be proven at trial, in a manner and amount that cannot be fully measured or compensated in economic terms, and for which there is no adequate remedy at law. The actions of the Defendants have damaged, and will continue to damage, Handi-Craft's business, market, reputation, and goodwill, and such irreparable damage will continue unless Defendants' acts are enjoined during the pendency of this action and thereafter.

PRAYER FOR RELIEF

WHEREFORE, Handi-Craft requests the Court to enter judgment in Handi-Craft's favor on all counts, granting Handi-Craft the following relief:

A. A preliminary and permanent injunction restraining and enjoining Defendants, its officers, directors, agents, counsel, servants, employees, and all of persons in active concert or participation with any of them, from alleging infringement of any claims of the '178 Patent against Handi-Craft or any customers, manufactures, users, importers, or sellers of Handi-Craft's Dino-Pour Bath Rinse Cup;

B. A declaration that Plaintiff has not infringed and is not infringing, either directly or indirectly, any valid and enforceable claim of the '178 Patent;

C. A declaration that each of the claims of the '178 Patent is invalid;

D. Damages for injuries suffered as a result of Defendants' unfair competition;

E. Actual, consequential, and punitive damages caused by Defendants' intentional and tortious interference with Handi-Craft's business expectancy with Amazon and customers using Amazon's website;

F. An order requiring Defendants to contact Amazon and retract the Amazon Complaint;

G. An order awarding Handi-Craft all of its costs and expenses;

H. An order finding this case exceptional and awarding Handi-Craft its attorneys' fees under 35 U.S.C. § 285; and

I. A judgment awarding Handi-Craft such other and further relief as the Court finds just and proper.

DEMAND FOR JURY TRIAL

Handi-Craft respectfully demands a jury trial on all claims and issues so triable.

Dated: January 23, 2023

Respectfully submitted,

/s/ Marc Vander Tuig

ARMSTRONG TEASDALE LLP
Marc. W. Vander Tuig – 52032 (MO)
Charlie M. Jonas – 74715 (MO)
7700 Forsyth Blvd, Suite 1800
St. Louis, Missouri 63105
(314) 621-5070 (telephone)
mvandertuig@atllp.com
cjonas@atllp.com

***Attorneys for Plaintiff Handi-Craft
Company***