

**IN THE UNITED STATES DISTRICT COURT
FOR THE EASTERN DISTRICT OF TEXAS
MARSHALL DIVISION**

REDWOOD TECHNOLOGIES, LLC,

Plaintiff,

v.

TEXAS INSTRUMENTS INCORPORATED,

Defendant.

§
§
§
§ **JURY TRIAL DEMANDED**
§
§
§ **C.A. NO. 2:23-cv-135**
§
§
§

PLAINTIFF’S COMPLAINT FOR PATENT INFRINGEMENT

Plaintiff Redwood Technologies, LLC (“Redwood”) files this Complaint against Defendant Texas Instruments Incorporated (“TI” or “Defendant”) for infringement of U.S. Patent No. 7,359,457 (the “457 patent”), U.S. Patent No. 7,688,901 (the “901 patent”), U.S. Patent No. 7,974,371 (the “371 patent”), U.S. Patent No. 8,284,866 (the “866 patent”), and U.S. Patent No. 9,374,209 (the “209 patent”), collectively, the “Asserted Patents.”

THE PARTIES

1. Redwood Technologies, LLC is a Texas limited liability company, with a principal place of business at 812 West McDermott Dr. #1038, Allen, TX 75013.

2. On information and belief, Texas Instruments Incorporated is a corporation organized and existing under the laws of Delaware, having a principal place of business at 12500 TI Boulevard, Dallas, Texas 75243. On information and belief, TI has business locations in this Judicial District at 6412 U.S. Highway 75, Sherman, Texas 75090; 300 W. Renner Road, Richardson, Texas 75080; and 2501 S. State Highway 121 Bus., Lewisville, Texas 75067. On information and belief, TI may be served in Texas via its registered agent, CT Corporation System, 1999 Bryan Street, Suite 900, Dallas, Texas 75201.

3. Prior to the filing of the Complaint, Redwood sent a letter received by TI on November 4, 2021, where Redwood attempted to engage TI in licensing discussions related to the Asserted Patents for reasonable and non-discriminatory terms for a license to be taken in the absence of litigation. TI ignored Redwood's request to engage in licensing discussions. Indeed, TI has known about each of the Asserted Patents since at least November 4, 2021, when TI received notice of its infringement of the Asserted Patents via the letter sent by Redwood.

4. Prior to the filing of the Complaint, Redwood sent another letter received by TI on May 23, 2022, where Redwood again attempted to engage TI in licensing discussions related to the Asserted Patents for reasonable and non-discriminatory terms for a license to be taken in the absence of litigation. TI again ignored Redwood's request to engage in licensing discussions. Indeed, TI has known about each of the Asserted Patents since at least May 23, 2022, when TI received the second notice of its infringement of the Asserted Patents via the letter sent by Redwood.

5. In addition, Texas Instruments has been on notice of both the '866 and '209 patents as stated herein as a result of forward citations from other TI patents during patent prosecution. Finally, as a member of the relevant standards-setting bodies, on information and belief, TI is on notice of standard essential patents issued to other members of the standards bodies.

6. TI's past and continuing making, using, selling, offering for sale, and/or importing, and/or inducing its subsidiaries, affiliates, retail partners, and customers in the making, using, selling, offering for sale, and/or importing the accused Wi-Fi compliant devices throughout the United States i) willfully infringe each of the Asserted Patents and ii) impermissibly take the significant benefits of Redwood's patented technologies without fair compensation to Redwood.

7. TI is engaged in making, using, selling, offering for sale, and/or importing, and/or induces its subsidiaries, affiliates, retail partners, and customers in the making, using, selling, offering for sale, and/or importing throughout the United States, including within this District, products, such as access points, accused of infringement.

JURISDICTION AND VENUE

8. This action arises under the patent laws of the United States, namely 35 U.S.C. §§ 271, 281, and 284-285, among others.

9. This Court has subject matter jurisdiction pursuant to 28 U.S.C. §§ 1331 and 1338(a).

10. This Court has personal jurisdiction over TI in accordance with due process and/or the Texas Long Arm Statute because, among other things, TI does business in this State by, among other things, maintaining offices in this District, including maintaining its offices located at 6412 U.S. Highway 75, Sherman, Texas 75090; 300 W. Renner Road, Richardson, Texas 75080; and 2501 S. State Highway 121 Bus., Lewisville, Texas 75067.

11. Further, this Court has personal jurisdiction over TI because it has engaged, and continues to engage, in continuous, systematic, and substantial activities within this State, including the substantial marketing, making, using, and sale of products and services within this State and this District. Indeed, this Court has personal jurisdiction over TI because it has committed acts giving rise to Redwood's claims for patent infringement within and directed to this District, has derived substantial revenue from its goods and services provided to individuals in this State and this District, and maintains regular and established places of business in this District, including its places of business at 6412 U.S. Highway 75, Sherman, Texas 75090; 300 W. Renner Road, Richardson, Texas 75080; and 2501 S. State Highway 121 Bus., Lewisville, Texas 75067.

12. Relative to patent infringement, TI has committed and continues to commit acts in violation of 35 U.S.C. § 271, and has made, used, marketed, distributed, offered for sale, imported, and/or sold infringing products in this State, including in this District, and otherwise engaged in infringing conduct within and directed at, or from, this District. Such products have been and continue to be offered for sale, distributed to, sold, and used in this District, and the infringing conduct has caused, and continues to cause, injury to Redwood, including injury suffered within this District. These are purposeful acts and transactions in this State and this District such that TI reasonably should know and expect that it could be haled into this Court because of such activities.

13. In addition, TI has knowingly induced and continues to knowingly induce infringement within this District by advertising, marketing, offering for sale and/or selling devices pre-loaded with infringing functionality within this District, to consumers, customers, manufacturers, distributors, resellers, partners, and/or end users, and providing instructions, user manuals, advertising, and/or marketing materials which facilitate, direct or encourage the use of infringing functionality with knowledge thereof.

14. Venue is proper in this District under 28 U.S.C. §§ 1391 and 1400(b) because TI has regular and established places of business in this District and has committed acts of infringement in this District. TI's regular and established places of business in this District include, at least, its facilities in 6412 U.S. Highway 75, Sherman, Texas 75090; 300 W. Renner Road, Richardson, Texas 75080; and 2501 S. State Highway 121 Bus., Lewisville, Texas 75067.

15. With respect to the '457 patent, the Accused Products are devices that include, but are not limited, to Defendant's devices that are compliant with IEEE 802.11n and/or IEEE 802.11ac and/or IEEE 802.11ax (e.g., CC3130, CC3230S, CC3230SF, CC3235MODAS, CC3235MODASF, CC3135MOD, CC3235MODS, CC3235MODSF, CC3135, CC3235S,

CC3235SF, CC3220MODA, CC3120MOD, CC3220MOD, CC3120, CC3220R, CC3220S, CC3220SF, WL1807MOD, WL1837MOD, CC3100MOD, CC3200MOD, CC3100, CC3200, WL1831, WL1801, WL1805MOD, WL1831MOD, WL1835MOD, WL1801MOD, CC3300, and CC3301) and other devices, as well as, their components, and processes related to the same. With respect to the '901 patent, the '371 patent, the '866 patent, and the '209 patent, the Accused Products are devices that include, but are not limited, to Defendant's devices that are compliant with IEEE 802.11n and/or IEEE 802.11ac and/or IEEE 802.11ax (e.g., WL1807MOD, WL1837MOD, WL1805MOD, and WL1835MOD), as well as, their components, and processes related to the same.¹

COUNT I

(INFRINGEMENT OF U.S. PATENT NO. 7,359,457)

16. Plaintiff incorporates paragraphs 1 through 15 herein by reference.

17. Redwood is the assignee of the '457 patent, entitled "Transmission Apparatus, Reception Apparatus and Digital Radio Communication Method," with ownership of all substantial rights in the '457 patent, including the right to exclude others and to enforce, sue, and recover damages for past and future infringements.

18. The '457 patent is valid, enforceable, and was duly issued in full compliance with Title 35 of the United States Code. The '457 patent issued from U.S. Patent Application No. 10/827,445.

19. TI has and continues to directly and/or indirectly infringe (by inducing infringement) one or more claims of the '457 patent in this judicial district and elsewhere in Texas and the United States.

¹ Each of the relevant standards cited herein, and related to the Asserted Patents, are specifically incorporated into this Complaint.

20. TI directly infringes the '457 patent via 35 U.S.C. § 271(a) by making, using, offering for sale, selling, and/or importing the Accused Products, their components and processes, and/or products containing the same that incorporate the fundamental technologies covered by the '457 patent.

21. For example, TI infringes claim 1 of the '457 patent via the Accused Products, including the WL1807MOD WiLink 8 industrial dual band combo, 2x2 MIMO Wi-Fi Module ("WL1807MOD"). The Accused Products, including the WL1807MOD, each are compliant with IEEE 802.11n and/or IEEE 802.11ac and/or IEEE 802.11ax, and each comprise a transmission apparatus of claim 1. *See, e.g.,* <https://www.ti.com/product/WL1807MOD>:

Features

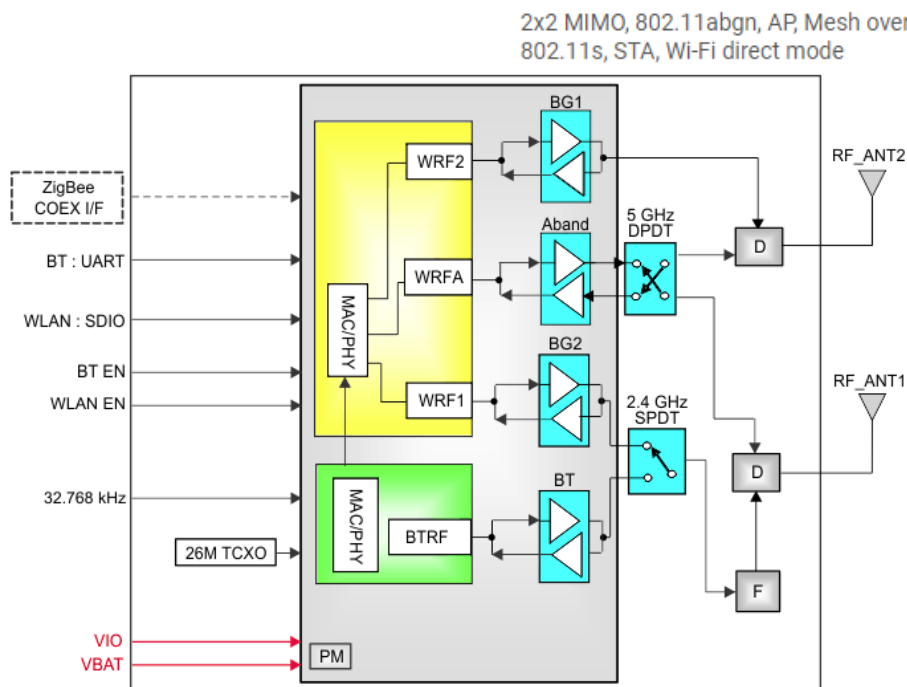

22. The Accused Products, including the WL1807MOD, each comprise circuitry and/or components (hardware and/or software) that determine a modulation system from among a plurality of modulation systems based on a communication situation. For example, the Accused Products utilize a Modulation and Coding Scheme (MCS) value that is used to determine the

modulation, coding, and number of spatial channels based on information associated with a channel quality assessment. *See, e.g.*, Sections 19.3.5 and 19.3.13.4 of Part 11: Wireless LAN Medium Access Control (MAC) and Physical (PHY) Specifications of IEEE Std 802.11™ -2016 (“IEEE 802.11 2016”). Based on the results of the channel quality assessment, the Accused Products select an appropriate MCS value from a plurality of MCS values. *See, e.g.*, Section 19.3.5 and Table 19-27 of IEEE 802.11 2016.

23. The Accused Products, including the WL1807MOD, each comprise circuitry and/or components (hardware and/or software) that modulate a digital transmission signal according to the modulation system previously determined and generates a first symbol. The first symbol comprises a first quadrature baseband signal. For example, the Accused Products, including the WL1807MOD, generate a first data symbol (e.g., Data), comprising a first quadrature baseband signal (*e.g.*, an OFDM signal before up-conversion to the carrier frequency), that is modulated according to the MCS value. *See, e.g.*, Section 19.3.5 and Figures 19-1 and 19-22 of IEEE 802.11 2016. The signal is a quadrature signal, in that it is expressed as a combination of sine and cosine waveforms. For example, when the 16-QAM modulation scheme is used, the following equation and constellation diagram are used to express the signal as a quadrature signal:

$$d = (I + jQ) \times K_{\text{MOD}} \quad (17-20)$$

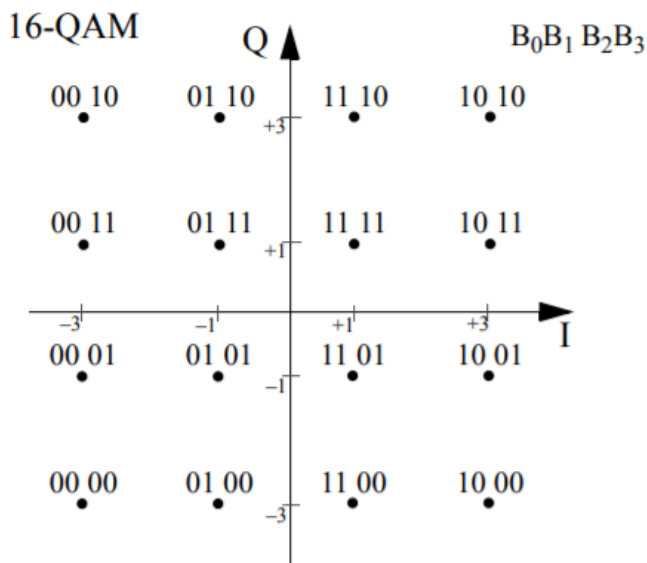

The signal is a quadrature signal because it is expressed with in-phase (I) and quadrature (Q) components. The signal is a baseband signal in that it has not been up-converted to the frequency of its intended carrier wave:

The transmitted signal is described in complex baseband signal notation. The actual transmitted signal is related to the complex baseband signal by the relation shown in Equation (19-1).

$$r_{RF}(t) = \text{Re}\{r(t)\exp(j2\pi f_c t)\} \quad (19-1)$$

where

f_c is the center frequency of the carrier

The transmitted RF signal is derived by modulating the complex baseband signal, which consists of several fields. The timing boundaries for the various fields are shown in Figure 19-4.

The mandatory PHY transmit procedure feature of annotated Figure 19-22 of IEEE 802.11 2016 is illustrated below:

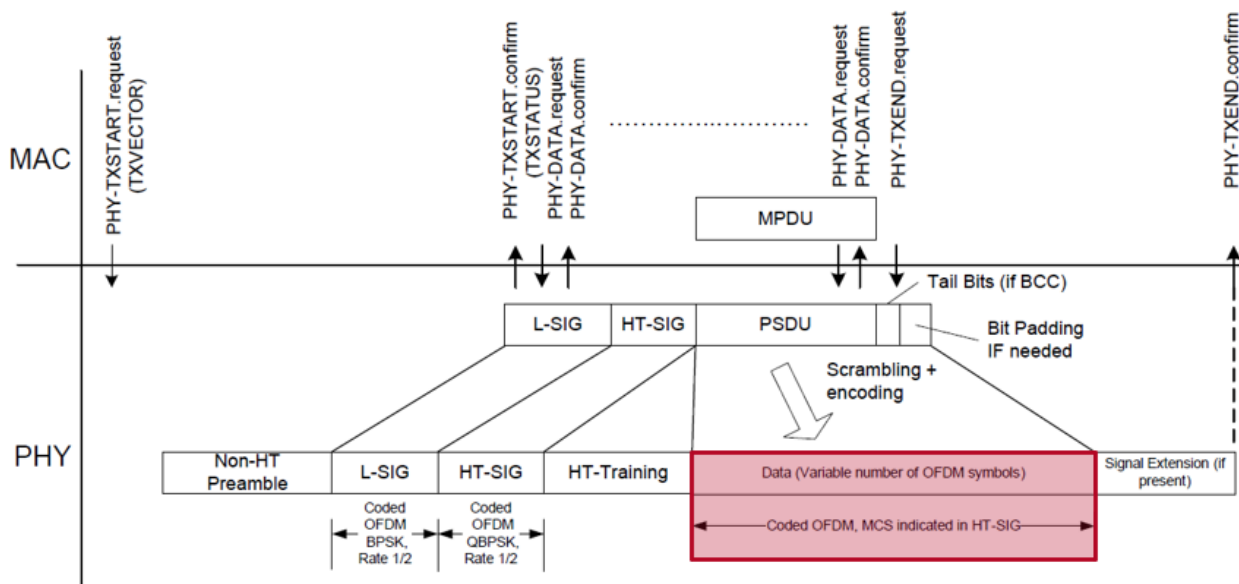

NOTE—This procedure does not describe the operation of optional features, such as LDPC or STBC

Figure 19-22—PHY transmit procedure (HT-mixed format PPDU)

Furthermore, an annotated passage of Section 19.3.20 directed to the mandatory “PHY transmit procedure” for HT-mixed format PPDU is recited below:

19.3.20 PHY transmit procedure

There are three options for the transmit PHY procedure. The first two options, for which typical transmit procedures are shown in Figure 19-22 and Figure 19-23, are selected if the FORMAT field of the PHY-TXSTART.request(TXVECTOR) primitive is equal to HT_MF or HT_GF, respectively. These transmit procedures do not describe the operation of optional features, such as LDPC or STBC. The third option is to follow the transmit procedure in Clause 17 or Clause 18 if the FORMAT field is equal to NON_HT. Additionally, if the FORMAT field is equal to NON_HT, CH_BANDWIDTH indicates

24. The option for the “transmit PHY procedure” as to the HT-mixed format PPDU is a mandatory feature of the standard. *See, e.g.,* https://www.albany.edu/faculty/dsaha/teach/2019Spring_CEN574/slides/08_WLAN.pdf at slides 67-68 (the HT-mixed format PPDU is mandatory). Thus, the Accused Devices, including the WL1807MOD, must be configured pursuant to Figures 19-1 and 19-22, as described above.

25. The Accused Products, including the WL1807MOD, each comprise circuitry and/or components (hardware and/or software) that modulates the digital signal according to a predetermined modulation system and generates a second symbol. The second symbol comprises a second quadrature baseband signal. For example, the Accused Products, including the WL1807MOD, generate a second data symbol (*e.g.*, the HT-SIG), comprising a second quadrature baseband signal (*e.g.*, OFDM signal before up-conversion to the carrier frequency), that is modulated according to a predetermined modulation system (*e.g.*, QBPSK). *See, e.g.*, Section 19.3.9.4.3 and Figures 19-1 and 19-22 of IEEE 802.11 2016. The signal is a quadrature signal, in that it is expressed as a combination of sine and cosine waveforms. For example, when the QBPSK modulation scheme is used, the following constellation diagram is used to express the signal as a quadrature signal:

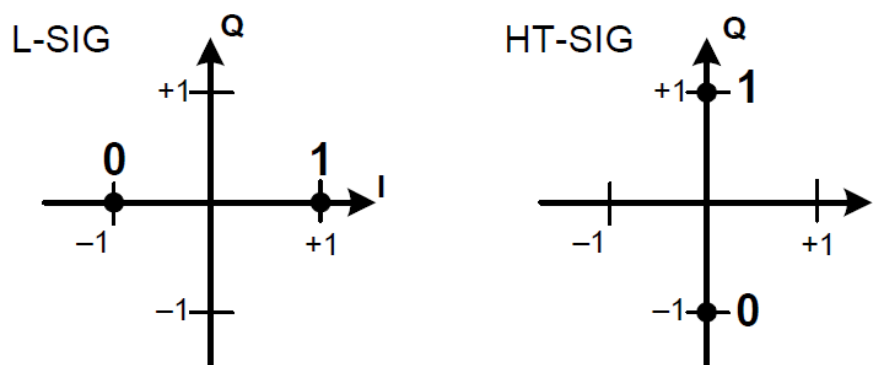

Figure 19-7—Data tone constellations in an HT-mixed format PPDU

The signal is a quadrature signal because it is expressed with in-phase (I) and quadrature (Q) components. The signal is a baseband signal in that it has not been up-converted to the frequency of its intended carrier wave:

The transmitted signal is described in complex baseband signal notation. The actual transmitted signal is related to the complex baseband signal by the relation shown in Equation (19-1).

$$r_{RF}(t) = \text{Re}\{r(t)\exp(j2\pi f_c t)\} \quad (19-1)$$

where

f_c is the center frequency of the carrier

The transmitted RF signal is derived by modulating the complex baseband signal, which consists of several fields. The timing boundaries for the various fields are shown in Figure 19-4.

26. The specific ways in which the Accused Products, including the WL1807MOD, are configured to support the aforementioned features of IEEE 802.11n and/or 802.11ac and/or 802.11ax are further detailed in confidential documents and/or source code that evidence infringement by the Accused Products, including the WL1807MOD, as to at least Claim 1 of the '457 patent.

27. Furthermore, the Accused Products, including the WL1807MOD, are configured or implemented in an infringing manner with the features and functionality recited in at least Claim 1 of the '457 patent.

28. The technology discussion above and the exemplary Accused Products provide context for Plaintiff's infringement allegations.

29. The claims of the '457 Patent are patent eligible under 35 U.S.C. § 101. The '457 Patent is not directed to an ineligible abstract idea. For example, it is not a mathematical algorithm executed on a generic computer or a fundamental economic business practice. Instead, for example, it offers a technologically complex, particularized "transmission apparatus, reception apparatus and digital radio communication method capable of flexibly improving the data transmission efficiency and the quality of data." '457 Patent, 1:59-63. The '457 Patent provides a technical solution above, for example, by using a "[f]rame configuration determination section"

that “judges the communication situation based on transmission path information” to determine a modulation system from a plurality of modulation systems, then generate symbols comprising quadrature baseband signals, including one symbol that is generated by modulating a digital transmission signal according to the selected modulation system and a second symbol that is generated by modulating the digital transmission signal according to a predetermined modulation system. ’457 Patent, 3:36-48; claim 1. That solution is reflected in the claims of the ’457 Patent such as independent claims 1 and 6.

30. At a minimum, TI has known of the ’457 patent at least as early as the filing date of the Complaint. In addition, TI has known about the ’457 patent since at least November 4, 2021, when TI and/or its agents received notice of its infringement via a letter. Furthermore, TI has known about the ’457 patent since at least May 23, 2022, when TI and/or its agents received notice of its infringement via another letter.

31. On information and belief, since at least the above-mentioned dates when TI was on notice of its infringement, TI has actively induced, under U.S.C. § 271(b), its distributors, customers, subsidiaries, importers, and/or consumers that import, use, purchase, offer to sell, or sell the Accused Products comprising all of the limitations of one or more claims of the ’457 patent to directly infringe one or more claims of the ’457 patent by using, offering for sale, selling, and/or importing the Accused Products. Since at least the notice provided on the above-mentioned dates, TI does so with knowledge, or with willful blindness of the fact, that the induced acts constitute infringement of the ’457 patent. TI intends to cause, and has taken affirmative steps to induce infringement by its distributors, importers, customers, subsidiaries, and/or consumers by at least, inter alia, creating advertisements that promote the infringing use of the Accused Products, creating and/or maintaining established distribution channels for the Accused Products into and

within the United States, manufacturing the Accused Products in conformity with U.S. laws and regulations, distributing or making available instructions or manuals for these products to purchasers and prospective buyers, testing and certifying features related to infringing features in the Accused Products, and/or providing technical support, replacement parts, or services for these products to these purchasers in the United States.

32. On information and belief, despite having knowledge of the '457 patent and knowledge that it is directly and/or indirectly infringing one or more claims of the '457 patent, TI has nevertheless continued its infringing conduct and disregarded an objectively high likelihood of infringement. TI's infringing activities relative to the '457 patent have been, and continue to be, willful, wanton, malicious, in bad-faith, deliberate, consciously wrongful, flagrant, characteristic of a pirate, and an egregious case of misconduct beyond typical infringement such that Plaintiff is entitled under 35 U.S.C. § 284 to enhanced damages up to three times the amount found or assessed.

33. Redwood has been damaged as a result of TI's infringing conduct described in this Count. TI is, thus, liable to Redwood in an amount that adequately compensates Redwood for TI's infringements, which, by law, cannot be less than a reasonable royalty, together with interest and costs as fixed by this Court under 35 U.S.C. § 284.

COUNT II

(INFRINGEMENT OF U.S. PATENT NO. 7,688,901)

34. Plaintiff incorporates paragraphs 1 through 33 herein by reference.

35. Redwood is the assignee of the '901 patent, entitled "Transmission Method, Transmission Apparatus, and Reception Apparatus," with ownership of all substantial rights in the '901 patent, including the right to exclude others and to enforce, sue, and recover damages for past and future infringements.

36. The '901 patent is valid, enforceable, and was duly issued in full compliance with Title 35 of the United States Code. The '901 patent issued from U.S. Patent Application No. 10/486,895.

37. TI has and continues to directly and/or indirectly infringe (by inducing infringement) one or more claims of the '901 patent in this judicial district and elsewhere in Texas and the United States.

38. TI directly infringes the '901 patent via 35 U.S.C. § 271(a) by using and/or testing the Accused Products, their components and processes, and/or products containing the same that incorporate the fundamental technologies covered by the '901 patent.

39. For example, TI infringes claim 1 of the '901 patent via the Accused Products. The Accused Products, including the WL1807MOD, transmit modulation signals. *See, e.g.*, Sections 19.1.1 and 19.1.2 of IEEE 802.11 2016; <https://www.ti.com/product/WL1807MOD>.

40. The Accused Products, including the WL1807MOD, each generate a plurality of modulation signals each of which is to be transmitted from a different one of a plurality of antennas, where each modulation signal is to include one or more preamble symbol groups each consisting of a plurality of preamble symbols used for demodulation. For example, the Accused Products generate modulation signals (e.g., HT-mixed format PPDUs) which are transmitted from a plurality of antennas. *See, e.g.*, Sections 19.3.3 of IEEE 802.11 2016. Each OFDM symbol within a modulation signal comprises a pilot symbol sequence consisting of four pilot symbols used for demodulation. *See, e.g.*, Sections 17.3.5.9 and 19.3.11.10 of IEEE 802.11 2016.

41. The Accused Products, including the WL1807MOD, each insert the one or more preamble symbol groups at the same one or more temporal points in each modulation signal, wherein the one or more preamble symbol groups at the one or more temporal points are orthogonal

to other preamble symbol groups at the same one or more temporal points with zero mutual correlation among the plurality of modulation signals, each preamble symbol having a non-zero amplitude, and each preamble symbol group consisting of preamble symbols the quantity of which is greater than that of the plurality of modulation signals to be transmitted. For example, each of the Accused Products insert one or more OFDM symbols comprising a pilot symbol sequence in each modulation signal, where each modulation signal sent from different antennas are transmitted simultaneously in time. *See, e.g.*, Section 19.3.11.10 of IEEE 802.11 2016. The pilot symbol sequences corresponding to different spatial streams are orthogonal at the same one or more temporal points with zero mutual correlation among the plurality of spatial streams. *See, e.g.*, Table 19-19 of IEEE 802.11 2016. The pilot symbols are BPSK modulated and have a non-zero amplitude. *See, e.g.*, Section 17.3.5.9 of IEEE 802.11 2016. Each pilot symbol sequence contains four pilot symbols, which is greater than the modulation signals to be transmitted by two or three antennas utilized by the Accused Products. *See, e.g.*, Sections 19.1.1 and 19.3.11.10 of IEEE 802.11 2016.

42. The Accused Products, including the WL1807MOD, each transmit the plurality of modulation signals, each comprising transmission data, which is different between the plurality of modulation signals, and the one or more preamble symbol groups, from the plurality of antennas, respectively, in an identical frequency band. For example, each of the Accused Products transmit the plurality of modulation signals comprising transmission data and the pilot symbol sequence from the two or three antennas in the same channel having a particular width (*e.g.*, 20 MHz). *See, e.g.*, Section 19.3.15.1, Tables 19-28, 19-29, and 19-30, and Figure 17-13 of IEEE 802.11 2016. Each stream of data to be transmitted is divided into multiple spatial streams to form respective

modulation signals having different transmission data during the encoding process. *See, e.g.*, Section 19.3.4 of IEEE 802.11 2016.

43. The specific ways in which the Accused Products, including the WL1807MOD, are configured to support the aforementioned features of IEEE 802.11n and/or 802.11ac and/or 802.11ax are further detailed in confidential documents and/or source code that evidence infringement by the Accused Products, including the WL1807MOD, as to Claim 1 of the '901 patent.

44. Furthermore, the Accused Products, including the WL1807MOD, are configured or implemented in an infringing manner with the features and functionality recited in at least Claim 1 of the '901 patent.

45. The technology discussion above and the exemplary Accused Products provide context for Plaintiff's infringement allegations.

46. The claims of the '901 Patent are patent eligible under 35 U.S.C. § 101. The '901 Patent is not directed to an ineligible abstract idea. For example, it is not a mathematical algorithm executed on a generic computer or a fundamental economic business practice. Instead, it is a technologically complex, particularized method of transmitting modulation signals. As the '901 Patent explains, the "present invention aims to provide a transmission method for estimating channels accurately and with ease from multiplexed modulation signals." '901 Patent, 1:50-52. The '901 Patent further explains that the "conventional structure gives no thought to the synchronization between channels in the same frequency band as well as a frequency offset. As a result, this structure encounters the difficulty of achieving the most important factor in order to demultiplex [sic] a multiplexed signal, namely, obtaining an accuracy of estimating channels." '901 Patent, 1:41-45.

47. The '901 Patent provides the technical solution above by, for example, “plac[ing] the symbols used for demodulation at an identical time of the respective channels and orthogonally to each other.” '901 Patent, 2:16-18. The '901 Patent explains that “[t]his preparation, i.e. the symbols used for demodulation are placed to be orthogonal to each other, allows the reception apparatus to isolate the symbols with ease for estimating channels.” '901 Patent, 2:18-22. That solution is reflected in the claims of the '901 Patent such as independent claim 1.

48. At a minimum, TI has known of the '901 patent at least as early as the filing date of the Complaint. In addition, TI has known about the '901 patent since at least November 4, 2021, when TI and/or its agents received notice of its infringement via a letter. Furthermore, TI has known about the '901 patent since at least May 23, 2022, when TI and/or its agents received notice of its infringement via another letter.

49. On information and belief, since at least the above-mentioned dates when TI was on notice of its infringement, TI has actively induced, under U.S.C. § 271(b), its distributors, customers, testing outfits, subsidiaries, importers, and/or consumers that use and/or test the Accused Products comprising all of the limitations of one or more claims of the '901 patent to directly infringe one or more claims of the '901 patent by using and/or testing the Accused Products. Since at least the notice provided on the above-mentioned dates, TI does so with knowledge, or with willful blindness of the fact, that the induced acts constitute infringement of the '901 patent. TI intends to cause, and has taken affirmative steps to induce infringement by its distributors, importers, customers, subsidiaries, and/or consumers by at least, inter alia, creating advertisements that promote the infringing use of the Accused Products, creating and/or maintaining established distribution channels for the Accused Products into and within the United States, manufacturing the Accused Products in conformity with U.S. laws and regulations,

distributing or making available instructions or manuals for these products to purchasers and prospective buyers, testing and certifying features related to infringing features in the Accused Products, and/or providing technical support, replacement parts, or services for these products to these purchasers in the United States.

50. On information and belief, despite having knowledge of the '901 patent and knowledge that it is directly and/or indirectly infringing one or more claims of the '901 patent, TI has nevertheless continued its infringing conduct and disregarded an objectively high likelihood of infringement. TI's infringing activities relative to the '901 patent have been, and continue to be, willful, wanton, malicious, in bad-faith, deliberate, consciously wrongful, flagrant, characteristic of a pirate, and an egregious case of misconduct beyond typical infringement such that Plaintiff is entitled under 35 U.S.C. § 284 to enhanced damages up to three times the amount found or assessed.

51. Redwood has been damaged as a result of TI's infringing conduct described in this Count. TI is, thus, liable to Redwood in an amount that adequately compensates Redwood for TI's infringements, which, by law, cannot be less than a reasonable royalty, together with interest and costs as fixed by this Court under 35 U.S.C. § 284.

COUNT III

(INFRINGEMENT OF U.S. PATENT NO. 7,974,371)

52. Plaintiff incorporates paragraphs 1 through 51 herein by reference.

53. Redwood is the assignee of the '371 patent, entitled "Communication Method and Radio Communication Apparatus," with ownership of all substantial rights in the '371 patent, including the right to exclude others and to enforce, sue, and recover damages for past and future infringements.

54. The '371 patent is valid, enforceable, and was duly issued in full compliance with Title 35 of the United States Code. The '371 patent issued from U.S. Patent Application No. 10/486,896.

55. TI has and continues to directly and/or indirectly infringe (by inducing infringement) one or more claims of the '371 patent in this judicial district and elsewhere in Texas and the United States.

56. TI directly infringes the '371 patent via 35 U.S.C. § 271(a) by making, using, offering for sale, selling, and/or importing the Accused Products, their components and processes, and/or products containing the same that incorporate the fundamental technologies covered by the '371 patent.

57. For example, TI infringes claim 14 of the '371 patent via the Accused Products, including the WL1807MOD. The Accused Products, including the WL1807MOD, comprise a radio transmission apparatus. *See, e.g.,* Fig. 19-2 of IEEE 802.11 2016; <https://www.ti.com/product/WL1807MOD>.

58. The Accused Products, including the WL1807MOD, each comprise circuitry and/or components (hardware and/or software) comprising a transmission method determining unit configured to select one of a first transmission method and a second transmission method based on received information of an estimated radio-wave propagation environment corresponding to a communication partner. For example, the Accused Products receive information associated with a channel quality assessment to select an appropriate Modulation and Coding Scheme (MCS) for Accused Products to utilize in subsequent transmissions to a receiving station, where the MCS value is utilized to determine the modulation, coding, and number of spatial channels based on

information associated with the channel quality assessment. *See, e.g.*, Sections 19.3.13.4 and 19.3.5 of IEEE 802.11 2016.

59. The Accused Products, including the WL1807MOD, each comprise circuitry and/or components (hardware and/or software) comprising a modulation signal generator configured to generate a single modulation signal if said transmission method determining unit choose selects said first transmission method, and to generate a plurality of modulation signals which include different information from each other for transmission to an identical frequency band at an identical temporal point, if said transmission method determining unit selects said second transmission method. For example, if the MCS indicates that a transmission will utilize only one spatial stream, the Accused Products generate a single modulation signal. *See, e.g.*, Section 19.3.5 of IEEE 802.11 2016. If the MCS indicates that a transmission will include multiple spatial streams for, *e.g.*, spatial multiplexing, a plurality of modulation signals are produced, where each of the modulation signals represents a respective spatial stream and each spatial stream includes distinct information. *See, e.g.*, Section 19.3.5 of IEEE 802.11 2016. Spatial multiplexing increases bandwidth by transmitting data over multiple available spatial channels. Transmissions are simultaneous and are transmitted using the same channel having a particular width (*e.g.*, 20 Mhz). *See, e.g.*, Section 19.3.15.1 and Tables 19-28, 19-29, and 19-30 of IEEE 802.11 2016.

60. The single modulation signal and the plurality of modulation signals contain information indicating the number of modulation signals to multiplex and transmit at the same time. For example, all HT transmissions of the Accused Products, including the WL1807MOD, utilize an HT-SIG, which contains an MCS that indicates the number of modulation signals to multiplex and transmit at the same time. *See, e.g.*, Sections 19.3.9.4.3 and 19.3.5 of IEEE 802.11 2016

61. The specific ways in which the Accused Products, including the WL1807MOD, are configured to support the aforementioned features of IEEE 802.11n and/or 802.11ac and/or 802.11ax are further detailed in confidential documents and/or source code that evidence infringement by the Accused Products as to at least Claim 14 of the '317 patent.

62. Furthermore, the Accused Products, including the WL1807MOD, are configured or implemented in an infringing manner with the features and functionality recited in at least Claim 14 of the '317 patent.

63. The technology discussion above and the exemplary Accused Products provide context for Plaintiff's infringement allegations.

64. The claims of the '371 Patent are patent eligible under 35 U.S.C. § 101. The '371 Patent is not directed to an ineligible abstract idea. For example, it is not a mathematical algorithm executed on a generic computer or a fundamental economic business practice. Instead, it offers, for example, a technologically complex communication method and a radio communication apparatus that, for example, "switches between the method of transmitting modulation signals of a plurality of channels to the same frequency band from a plurality of antennas and the method of transmitting a modulation signal of one channel from an antenna." '371 Patent, 4:27-31. This allows the transmitter to choose which of these transmission methods is used, based on estimated channel conditions. The '371 Patent explains that "when the communication method is used, which multiplexes modulation signals of a plurality of channels to the same frequency band, a receiver transmits the information of an estimated radio-wave propagation environment to a transmitter. The transmitter then selects a communication method based on the information. Multiplexing modulation signals of a plurality of channels to the same frequency band by using the foregoing method can increase the data transmission rate. At the same time, a radio communication apparatus

of the present invention can advantageously demultiplex the multiplexed modulation signals received with ease.” ’371 Patent, 5:4-16. That solution is reflected in, for example, claim 14 of the ’371 Patent.

65. At a minimum, TI has known of the ’371 patent at least as early as the filing date of the Complaint. In addition, TI has known about the ’371 patent since at least November 4, 2021, when TI and/or its agents received notice of its infringement via a letter. Furthermore, TI has known about the ’371 patent since at least May 23, 2022, when TI and/or its agents received notice of its infringement via another letter.

66. On information and belief, since at least the above-mentioned dates when TI was on notice of its infringement, TI has actively induced, under U.S.C. § 271(b), its distributors, customers, subsidiaries, importers, and/or consumers that import, use, purchase, offer to sell, or sell the Accused Products comprising all of the limitations of one or more claims of the ’371 patent to directly infringe one or more claims of the ’371 patent by using, offering for sale, selling, and/or importing the Accused Products. Since at least the notice provided on the above-mentioned dates, TI does so with knowledge, or with willful blindness of the fact, that the induced acts constitute infringement of the ’371 patent. TI intends to cause, and has taken affirmative steps to induce infringement by its distributors, importers, customers, subsidiaries, and/or consumers by at least, inter alia, creating advertisements that promote the infringing use of the Accused Products, creating and/or maintaining established distribution channels for the Accused Products into and within the United States, manufacturing the Accused Products in conformity with U.S. laws and regulations, distributing or making available instructions or manuals for these products to purchasers and prospective buyers, testing and certifying features related to infringing features in

the Accused Products, and/or providing technical support, replacement parts, or services for these products to these purchasers in the United States.

67. On information and belief, despite having knowledge of the '371 patent and knowledge that it is directly and/or indirectly infringing one or more claims of the '371 patent, TI has nevertheless continued its infringing conduct and disregarded an objectively high likelihood of infringement. TI's infringing activities relative to the '371 patent have been, and continue to be, willful, wanton, malicious, in bad-faith, deliberate, consciously wrongful, flagrant, characteristic of a pirate, and an egregious case of misconduct beyond typical infringement such that Plaintiff is entitled under 35 U.S.C. § 284 to enhanced damages up to three times the amount found or assessed.

68. Redwood has been damaged as a result of TI's infringing conduct described in this Count. TI is, thus, liable to Redwood in an amount that adequately compensates Redwood for TI's infringements, which, by law, cannot be less than a reasonable royalty, together with interest and costs as fixed by this Court under 35 U.S.C. § 284.

COUNT IV

(INFRINGEMENT OF U.S. PATENT NO. 8,284,866)

69. Plaintiff incorporates paragraphs 1 through 68 herein by reference.

70. Redwood is the assignee of the '866 patent, entitled "OFDM Transmission Signal Generation Apparatus and Method, and OFDM Reception Data Generation Apparatus and Method," with ownership of all substantial rights in the '866 patent, including the right to exclude others and to enforce, sue, and recover damages for past and future infringements.

71. The '866 patent is valid, enforceable, and was duly issued in full compliance with Title 35 of the United States Code. The '866 patent issued from U.S. Patent Application No. 13/171,121.

72. TI has and continues to directly and/or indirectly infringe (by inducing infringement) one or more claims of the '866 patent in this judicial district and elsewhere in Texas and the United States.

73. TI directly infringes the '866 patent via 35 U.S.C. § 271(a) by making, using, offering for sale, selling, and/or importing the Accused Products, their components and processes, and/or products containing the same that incorporate the fundamental technologies covered by the '866 patent.

74. For example, TI infringes claim 1 of the '866 patent via the Accused Products, including the WL1807MOD. The Accused Products, including the WL1807MOD, comprise an OFDM transmission signal generation apparatus. *See, e.g.*, Figure 19-3 of IEEE 802.11 2016; <https://www.ti.com/product/WL1807MOD>.

75. The Accused Products, including the WL1807MOD, each comprise circuitry and/or components (hardware and/or software) configured to form a plurality of transmission signals, where each of the plurality of transmission signals comprises several pilot carriers, which are located in identical carrier positions among the plurality of transmission signals. For example, each of the Accused Products comprises a spatial mapper configured to form a plurality of OFDM signals. *See, e.g.*, Section 19.3.3 and Figure 19-3 of IEEE 802.11 2016. Further, each of the OFDM signals contains, for example, four pilot carriers, in a 20MHz transmission, inserted in carrier positions of -21, -7, 7, and 21, or six pilot carriers, in a 40MHz transmission, inserted in carrier positions of -53, -25, -11, 11, 25, and 53. *See, e.g.*, Section 19.3.11.10 and Equation 19-54 of IEEE 802.11 2016. Orthogonal pilot sequences are assigned to identical time slots of pilot carriers in identical carrier positions among the plurality of OFDM signals, and identical pilot sequences are

assigned to at least two of the OFDM signals. *See, e.g.*, Section 19.3.11.10 and Table 19-19 of IEEE 802.11 2016.

76. The Accused Products, including the WL1807MOD, each comprise circuitry and/or components (hardware and/or software) of an Inverse Fourier transform section configured to convert the plurality of transmission signals to a plurality of OFDM signals to be transmitted over an identical frequency band at an identical time. *See, e.g.*, Section 19.3.3 and Figure 19-3 of IEEE 802.11 2016. For example, the Accused Products are configured to send simultaneous transmissions that are transmitted using the same channel (*e.g.*, a channel having a width of 20 MHz). *See, e.g.*, Section 19.3.15.1 and Tables 19-28, 19-29, and 19-30 of IEEE 802.11 2016.

77. The specific ways in which the Accused Products, including the WL1807MOD, are configured to support the aforementioned features of IEEE 802.11 2016 are further detailed in confidential documents and/or source code that evidence infringement by the Accused Products as to Claim 1 of the '866 patent.

78. Furthermore, the Accused Products, including the WL1807MOD, are configured or implemented in an infringing manner with the features and functionality recited in at least Claim 1 of the '866 patent.

79. The technology discussion above and the exemplary Accused Products provide context for Plaintiff's infringement allegations.

80. The claims of the '866 Patent are patent eligible under 35 U.S.C. § 101. The '866 Patent is not directed to an ineligible abstract idea. For example, it is not a mathematical algorithm executed on a generic computer or a fundamental economic business practice. Instead, it offers, for example, a technologically complex MIMO-OFDM transmission apparatus and method that allows "realizing an ideal symbol configuration for frequency offset estimation, transmission path

fluctuation (channel fluctuation) estimation and synchronization/signal detection, in MIMO-OFDM communication.” ’866 Patent, 1:21-24.

81. The ’866 Patent explains that “sufficient consideration has not been given to the method of transmitting symbols for transmission path estimation and symbols for frequency offset estimation to realize high accuracy frequency offset estimation, high accuracy transmission path fluctuation estimation and high accuracy synchronization/signal detection.” ’866 Patent, 1:21-24. The ’866 Patent solves this problem with technical solutions. For example, the ’866 Patent explains that, in a configuration of its invention, “orthogonal sequences are assigned to corresponding subcarriers among OFDM signals transmitted at the same time from the respective antennas in the time domain to form pilot carriers, so that, even when pilot symbols are multiplexed among a plurality of channels (antennas), it is possible to estimate frequency offset/phase noise with high accuracy.” ’866 Patent, 3:4-10. That solution is reflected in, for example, claim 1 of the ’866 Patent.

82. At a minimum, TI has known of the ’866 patent at least as early as the filing date of the Complaint. In addition, TI has known about the ’866 patent since at least November 4, 2021, when TI and/or its agents received notice of the ’866 patent via a letter. Furthermore, TI has known about the ’866 patent since at least May 23, 2022, when TI and/or its agents received notice of its infringement via another letter. In addition, TI has had knowledge of the ’866 Patent based at least on its conduct before the United States Patent and Trademark Office (“USPTO”). For example, the ’866 patent was cited by the Examiner during the prosecution of U.S. Patent No. 8,265,197 entitled “OFDM transmission methods in three phase modes” and assigned to TI.

83. On information and belief, since at least the above-mentioned dates when TI was on notice of its infringement, TI has actively induced, under U.S.C. § 271(b), its distributors,

customers, subsidiaries, importers, and/or consumers that import, use, purchase, offer to sell, or sell the Accused Products comprising all of the limitations of one or more claims of the '866 patent to directly infringe one or more claims of the '866 patent by using, offering for sale, selling, and/or importing the Accused Products. Since at least the notice provided on the above-mentioned dates, TI does so with knowledge, or with willful blindness of the fact, that the induced acts constitute infringement of the '866 patent. TI intends to cause, and has taken affirmative steps to induce infringement by its distributors, importers, customers, subsidiaries, and/or consumers by at least, inter alia, creating advertisements that promote the infringing use of the Accused Products, creating and/or maintaining established distribution channels for the Accused Products into and within the United States, manufacturing the Accused Products in conformity with U.S. laws and regulations, distributing or making available instructions or manuals for these products to purchasers and prospective buyers, testing and certifying features related to infringing features in the Accused Products, and/or providing technical support, replacement parts, or services for these products to these purchasers in the United States.

84. On information and belief, despite having knowledge of the '866 patent and knowledge that it is directly and/or indirectly infringing one or more claims of the '866 patent, TI has nevertheless continued its infringing conduct and disregarded an objectively high likelihood of infringement. TI's infringing activities relative to the '866 patent have been, and continue to be, willful, wanton, malicious, in bad-faith, deliberate, consciously wrongful, flagrant, characteristic of a pirate, and an egregious case of misconduct beyond typical infringement such that Plaintiff is entitled under 35 U.S.C. § 284 to enhanced damages up to three times the amount found or assessed.

85. Redwood has been damaged as a result of TI's infringing conduct described in this Count. TI is, thus, liable to Redwood in an amount that adequately compensates Redwood for TI's infringements, which, by law, cannot be less than a reasonable royalty, together with interest and costs as fixed by this Court under 35 U.S.C. § 284.

COUNT V

(INFRINGEMENT OF U.S. PATENT NO. 9,374,209)

86. Plaintiff incorporates paragraphs 1 through 85 herein by reference.

87. Redwood is the assignee of the '209 patent, entitled "Transmission Signal Generation Apparatus, Transmission Signal Generation Method, Reception Signal Apparatus, and Reception Signal Method," with ownership of all substantial rights in the '209 patent, including the right to exclude others and to enforce, sue, and recover damages for past and future infringements.

88. The '209 patent is valid, enforceable, and was duly issued in full compliance with Title 35 of the United States Code. The '209 patent issued from U.S. Patent Application No. 14/703,938.

89. TI has and continues to directly and/or indirectly infringe (by inducing infringement) one or more claims of the '209 patent in this judicial district and elsewhere in Texas and the United States.

90. TI directly infringes the '209 patent via 35 U.S.C. § 271(a) by making, using, offering for sale, selling, and/or importing the Accused Products, their components and processes, and/or products containing the same that incorporate the fundamental technologies covered by the '209 patent.

91. For example, TI infringes claim 11 of the '209 patent via the Accused Products, including the WL1807MOD. The Accused Products, including the WL1807MOD, comprise a

transmission signal generation apparatus configured to generate transmission signals (*e.g.*, HT-mixed format transmission signals). *See, e.g.*, Figure 19-2 of IEEE 802.11 2016; <https://www.ti.com/product/WL1807MOD>.

92. The Accused Products, including the WL1807MOD, each comprise circuitry and/or components (hardware and/or software) configured to generate one or more transmission signals, where each transmission signal includes a data frame having preamble information, pilot information, and data information. *See, e.g.*, Sections 19.3.3 and 19.3.20 and Figure 19-2 of IEEE 802.11 2016. Further, each of the transmission signals include the PHY preamble, at least four pilot symbols, and data information. *See, e.g.*, Sections 19.3.1, 19.3.11.10, and 19.3.20 of IEEE 802.11 2016.

93. Each of the one or more transmission signals includes an associated preamble multiplied by a factor so that an average reception power of the associated preamble corresponds to an average reception power of the data information received with the associated preamble. For example, each of the transmission signals is multiplied by a normalization factor corresponding to the modulation scheme to achieve the same average power for all mappings, where the preamble and data information can have different modulation types and therefore different corresponding normalization factors. *See, e.g.*, Section 17.3.5.8, Table 17-11, Equation 17-20, and Figure 17.1 of IEEE 802.11 2016.

94. Each of the one or more transmission signals includes plural pilot symbol sequences. For example, each of the transmission signals include at least four pilot symbols inserted in, for example, carrier positions -21, -7, 7, and 21. *See, e.g.*, Section 19.3.11.10 and Figure 19-3 of IEEE 802.11 2016.

95. The Accused Products, including the WL1807MOD, each comprise circuitry and/or components (hardware and/or software) of an Inverse Fourier transformer configured to generate for each of the one or more transmission signals a corresponding OFDM signal for transmission by a corresponding one of one or more antennas by Inverse Fourier transforming each of the transmission signals. *See, e.g.*, Section 19.3.3 and Figure 19-3 of IEEE 802.11 2016.

96. The Inverse Fourier transformer of each of the Accused Products, including the WL1807MOD, is configured to arrange the pilot symbol sequences in corresponding pilot carriers during a first time period. For example, the Inverse Fourier transformer is configured to arrange pilot sequences in the pilot carriers of each OFDM symbol transmitted during a first time period (*e.g.*, the 3.2 μ s DFT period). *See, e.g.*, Section 19.3.6, 19.3.11.10, 19.3.21, 19.4.3, and Equation 19-90 of IEEE 802.11 2016.

97. The transmitter of each of the Accused Products, including the WL1807MOD, is configured to arrange sets of the pilot carriers in a same carrier position in the OFDM signal, where the plural pilot symbol sequences are all orthogonal to each other. For example, the transmitter is configured to arrange pilot sequences for each space-time stream, where each of the OFDM signals contains four pilot carriers inserted in, for example, carrier positions -21, -7, 7, and 21. *See, e.g.*, Section 19.3.11.10, Equation 19-54, and Table 19-19 of IEEE 802.11 2016. Pilot sequences corresponding to different spatial streams are orthogonal to each other. *See, e.g.*, Table 19-19 of IEEE 802.11 2016.

98. The specific ways in which the Accused Products, including the WL1807MOD, are configured to support the aforementioned features of IEEE 802.11 2016 are further detailed in confidential documents and/or source code that evidence infringement by the Accused Products as to at least Claim 11 of the '209 patent.

99. Furthermore, the Accused Products, including the WL1807MOD, are configured or implemented in an infringing manner with the features and functionality recited in at least Claim 11 of the '209 patent.

100. The technology discussion above and the exemplary Accused Products provide context for Plaintiff's infringement allegations.

101. The claims of the '209 Patent are patent eligible under 35 U.S.C. § 101. The '209 Patent is not directed to an ineligible abstract idea. For example, it is not a mathematical algorithm executed on a generic computer or a fundamental economic business practice.

102. The '209 Patent explains that "in the present circumstances, sufficient consideration has not been given to the method of transmitting symbols for transmission path estimation and symbols for frequency offset estimation to realize high accuracy frequency offset estimation, high accuracy transmission path fluctuation estimation and high accuracy synchronization/signal detection." '209 Patent, 2:53-59. The '209 Patent provides a technical solution to achieve high accuracy frequency offset by assigning orthogonal sequences to corresponding subcarriers among OFDM signals transmitted at the same time from the respective antennas in the time domain to form pilot carriers. '209 Patent, 3:9-15. The '209 Patent further explains that, in the technical solution of its invention, "since pilot symbols of each channel can be extracted without using a channel estimator value (transmission path fluctuation estimation value), it is possible to simplify the configuration of the section for compensating for the frequency offset/phase noise." '209 Patent, 3:15-19. Those solutions are reflected in, for example, claim 11 of the '209 Patent.

103. At a minimum, TI has known of the '209 patent at least as early as the filing date of the Complaint. In addition, TI has known about the '209 patent since at least November 4, 2021,

when TI and/or its agents received notice the '209 patent via a letter. Furthermore, TI has known about the '209 patent since at least May 23, 2022, when TI and/or its agents received notice of its infringement via another letter. In addition, TI has had knowledge of the '209 Patent based at least on its conduct before the United States Patent and Trademark Office (“USPTO”). For example, the '209 patent was cited by the Examiner during the prosecution of U.S. Patent No. 8,265,197 entitled “OFDM transmission methods in three phase modes” and assigned to TI.

104. On information and belief, since at least the above-mentioned dates when TI was on notice of its infringement, TI has actively induced, under U.S.C. § 271(b), its distributors, customers, subsidiaries, importers, and/or consumers that import, use, purchase, offer to sell, or sell the Accused Products comprising all of the limitations of one or more claims of the '209 patent to directly infringe one or more claims of the '209 patent by using, offering for sale, selling, and/or importing the Accused Products. Since at least the notice provided on the above-mentioned dates, TI does so with knowledge, or with willful blindness of the fact, that the induced acts constitute infringement of the '209 patent. TI intends to cause, and has taken affirmative steps to induce infringement by its distributors, importers, customers, subsidiaries, and/or consumers by at least, inter alia, creating advertisements that promote the infringing use of the Accused Products, creating and/or maintaining established distribution channels for the Accused Products into and within the United States, manufacturing the Accused Products in conformity with U.S. laws and regulations, distributing or making available instructions or manuals for these products to purchasers and prospective buyers, testing and certifying features related to infringing features in the Accused Products, and/or providing technical support, replacement parts, or services for these products to these purchasers in the United States.

105. On information and belief, despite having knowledge of the '209 patent and knowledge that it is directly and/or indirectly infringing one or more claims of the '209 patent, TI has nevertheless continued its infringing conduct and disregarded an objectively high likelihood of infringement. TI's infringing activities relative to the '209 patent have been, and continue to be, willful, wanton, malicious, in bad-faith, deliberate, consciously wrongful, flagrant, characteristic of a pirate, and an egregious case of misconduct beyond typical infringement such that Plaintiff is entitled under 35 U.S.C. § 284 to enhanced damages up to three times the amount found or assessed.

106. Redwood has been damaged as a result of TI's infringing conduct described in this Count. TI is, thus, liable to Redwood in an amount that adequately compensates Redwood for TI's infringements, which, by law, cannot be less than a reasonable royalty, together with interest and costs as fixed by this Court under 35 U.S.C. § 284.

CONCLUSION

107. Plaintiff Redwood is entitled to recover from TI the damages sustained by Plaintiff as a result of TI's wrongful acts, and willful infringement, in an amount subject to proof at trial, which, by law, cannot be less than a reasonable royalty, together with interest and costs as fixed by this Court.

108. Plaintiff has incurred and will incur attorneys' fees, costs, and expenses in the prosecution of this action. The circumstances of this dispute may give rise to an exceptional case within the meaning of 35 U.S.C. § 285, and Plaintiff is entitled to recover its reasonable and necessary attorneys' fees, costs, and expenses.

JURY DEMAND

109. Plaintiff hereby requests a trial by jury pursuant to Rule 38 of the Federal Rules of Civil Procedure.

PRAYER FOR RELIEF

110. Plaintiff respectfully requests that the Court find in its favor and against TI, and that the Court grant Plaintiff the following relief:

1. A judgment that TI has infringed the Asserted Patents as alleged herein, directly and/or indirectly by way of inducing infringement of such patents;
2. A judgment for an accounting of all damages sustained by Plaintiff as a result of the acts of infringement by TI;
3. A judgment and order requiring TI to pay Plaintiff damages under 35 U.S.C. § 284, including up to treble damages as provided by 35 U.S.C. § 284, and any royalties determined to be appropriate;
4. A judgment and order requiring TI to pay Plaintiff pre-judgment and post-judgment interest on the damages awarded;
5. A judgment and order finding this to be an exceptional case and requiring TI to pay the costs of this action (including all disbursements) and attorneys' fees as provided by 35 U.S.C. § 285; and
6. Such other and further relief as the Court deems just and equitable.

Dated: March 29, 2023

Respectfully submitted,

/s/ Patrick J. Conroy

Patrick J. Conroy

Texas Bar No. 24012448

T. William Kennedy Jr.

Texas Bar No. 24055771

Jon Rastegar

Texas Bar No. 24064043

Nelson Bumgardner Conroy PC

2727 N. Harwood St.

Suite 250

Dallas, TX 75201

Tel: (214) 446-4950

pat@nelbum.com

bill@nelbum.com

jon@nelbum.com

John P. Murphy

Texas Bar No. 24056024

Nelson Bumgardner Conroy PC

3131 W 7th St

Suite 300

Fort Worth, TX 76107

Tel: (817) 377-9111

murphy@nelbum.com

Attorneys for Plaintiff

Redwood Technologies, LLC