

**IN THE UNITED STATES DISTRICT COURT
FOR THE EASTERN DISTRICT OF TEXAS
MARSHALL DIVISION**

JAWBONE INNOVATIONS, LLC,	§	Case No.
	§	
Plaintiff,	§	<u>JURY TRIAL DEMANDED</u>
	§	
v.	§	
	§	
HTC CORPORATION,	§	
	§	
Defendant.	§	
	§	

COMPLAINT FOR PATENT INFRINGEMENT

Plaintiff Jawbone Innovations, LLC (“Jawbone” or “Plaintiff”) for its Complaint against Defendant HTC Corporation (“HTC” or “Defendant”) alleges as follows:

THE PARTIES

1. Jawbone is a limited liability company organized and existing under the laws of the State of Texas, with places of business located at 104 East Houston Street, Suite 165, Marshall, Texas 75670 and 2226 Washington Avenue, Suite Number 1, Waco, Texas 76701.

2. Defendant HTC is a corporation formed under the laws of Taiwan, with its principal place of business at No. 23, Xinghua Road, Taoyuan District, Taoyuan, Taipei, Taiwan 330. Upon information and belief, HTC does business in Texas, directly and through intermediaries, and offers its products, and services, including those accused herein of infringement, to customers and potential customers located in Texas, including in this Judicial District.

JURISDICTION AND VENUE

3. This is an action for patent infringement arising under the patent laws of the United States, 35 U.S.C. §§ 1, *et seq.* This Court has subject matter jurisdiction over this action pursuant to 28 U.S.C. §§ 1331, 1332, 1338, and 1367.

4. This Court has specific and personal jurisdiction over HTC consistent with the requirements of the Due Process Clause of the United States Constitution and the Texas Long Arm Statute. Upon information and belief, HTC has sufficient minimum contacts with the forum because HTC transacts substantial business in the State of Texas and in this Judicial District. Further, HTC has, directly or through subsidiaries or intermediaries, committed and continues to commit acts of patent infringement in the State of Texas and in this Judicial District as alleged in this Complaint, as alleged more particularly below. For example, on information and belief, the Accused Products are available for purchase in this Judicial District.

5. Venue is proper in this Judicial District pursuant to 28 U.S.C. §1391(b) and (c) because HTC is a foreign company that may be sued in any Judicial District, including the Eastern District of Texas. HTC is subject to personal jurisdiction in this Judicial District and has committed acts of patent infringement in this Judicial District. On information and belief, HTC through its own acts and/or through the acts of others, makes, uses, sells, offers to sell, and/or imports infringing products within this Judicial District, regularly does and solicits business in this Judicial District, and has the requisite minimum contacts with the Judicial District such that this venue is a fair and reasonable one. Further, upon information and belief, HTC has admitted or not contested proper venue in this Judicial District in other patent infringement actions.

FACTUAL BACKGROUND

6. On September 13, 2011, the United States Patent and Trademark Office duly and legally issued U.S. Patent No. 8,019,091 (the “’091 Patent”) entitled “Voice Activity Detector (VAD)-Based Multiple-Microphone Acoustic Noise Suppression.” A true and correct copy of the ’091 Patent is available at: <https://image-ppubs.uspto.gov/dirsearch-public/print/downloadPdf/8019091>.

7. On July 17, 2007, the United States Patent and Trademark Office duly and legally issued U.S. Patent No. 7,246,058 (the “’058 Patent”) entitled “Detecting Voiced and Unvoiced Speech Using Both Acoustic and Nonacoustic Sensors.” A true and correct copy of the ’058 Patent is available at: <https://image-ppubs.uspto.gov/dirsearch-public/print/downloadPdf/7246058>.

8. On September 15, 2020, the United States Patent and Trademark Office duly and legally issued U.S. Patent No. 10,779,080 (the “’080 Patent”) entitled “Dual Omnidirectional Microphone Array (DOMA).” A true and correct copy of the ’080 Patent is available at: <https://image-ppubs.uspto.gov/dirsearch-public/print/downloadPdf/10779080>.

9. On September 14, 2021, the United States Patent and Trademark Office duly and legally issued U.S. Patent No. 11,122,357 (the “’357 Patent”) entitled “Forming Virtual Microphone Arrays Using Dual Omnidirectional Microphone Array (DOMA).” A true and correct copy of the ’357 Patent is available at: <https://image-ppubs.uspto.gov/dirsearch-public/print/downloadPdf/11122357>.

10. On June 18, 2013, the United States Patent and Trademark Office duly and legally issued U.S. Patent No. 8,467,543 (the “’543 Patent”) entitled “Microphone and Voice Activity Detection (VAD) Configurations For Use with Communications Systems.” A true and correct

copy of the '543 Patent is available at: <https://image-ppubs.uspto.gov/dirsearch-public/print/downloadPdf/8467543>.

11. On August 6, 2013, the United States Patent and Trademark Office duly and legally issued U.S. Patent No. 8,503,691 (the "'691 Patent") entitled "Virtual Microphone Arrays Using Dual Omnidirectional Microphone Array (DOMA)." A true and correct copy of the '691 Patent is available at: <https://image-ppubs.uspto.gov/dirsearch-public/print/downloadPdf/8503691>.

12. On November 27, 2012, the United States Patent and Trademark Office duly and legally issued U.S. Patent No. 8,321,213 (the "'213 Patent") entitled "Acoustic Voice Activity Detection (AVAD) for Electronic Systems." A true and correct copy of the '213 Patent is available at: <https://image-ppubs.uspto.gov/dirsearch-public/print/downloadPdf/8321213>.

13. On December 4, 2012, the United States Patent and Trademark Office duly and legally issued U.S. Patent No. 8,326,611 (the "'611 Patent") entitled "Acoustic Voice Activity Detection (AVAD) for Electronic Systems." A true and correct copy of the '611 Patent is available at: <https://image-ppubs.uspto.gov/dirsearch-public/print/downloadPdf/8326611>.

14. Jawbone is the sole and exclusive owner of all right, title, and interest to and in the '091 Patent, '058 Patent, '080 Patent, '357 Patent, '543 Patent, '691 Patent, '213 Patent, and '611 Patent (together, the "Patents-in-Suit"), and holds the exclusive right to take all actions necessary to enforce its rights to the Patents-in-Suit, including the filing of this patent infringement lawsuit. Jawbone also has the right to recover all damages for past, present, and future infringement of the Patents-in-Suit and to seek injunctive relief as appropriate under the law.

15. The technology of the Patents-in-Suit was developed by AliphCom dba Jawbone, which was originally founded in 1998 as AliphCom. AliphCom set out to develop a noise reducing headset that would allow soldiers to communicate better in combat conditions. In 2002, AliphCom

won a contract with the Defense Advanced Research Projects Agency to research noise suppression techniques for the United States military.

16. AliphCom launched a mobile headset called the “Jawbone” in 2004. The “Jawbone” included the innovative noise-suppression technology that AliphCom developed for the military.¹ This technology virtually eliminated background noise while increasing the volume of the speakers’ voices. AliphCom followed with a Bluetooth version of the “Jawbone” in 2008 which was sold in the Apple Store.

17. On the heels of the success of the “Jawbone” products, AliphCom changed its name to Jawbone, Inc. in 2011 and later expanded its product offerings into Bluetooth speakers and wearables, such as health tracking devices. Unfortunately, due to the intensely competitive marketplace, Jawbone, Inc. was forced into liquidation in 2017.

18. Upon information and belief, following Jawbone, Inc.’s liquidation, Envision IP (and other parties) contacted HTC regarding the value of the Patents-in-Suit, including regarding HTC’s infringement of the Patents-in-Suit and specifically identifying at least the ’091 Patent and the ’058 Patent. Upon information and belief, HTC was notified that HTC virtual reality headsets, home devices, and smartphones (the “Accused Products”) infringe the Patents-in-Suit, and/or otherwise became aware of the Patents-in-Suit and recognized that the Accused Products infringe the Patents-in-Suit at least as of 2017. Furthermore, in or about October 2019, HTC received correspondence email notifying HTC of the availability of the Jawbone portfolio for potential purchase and/or licensing.

¹See <https://www.wired.com/2004/09/military-headset-reaches-masses/>

INFRINGEMENT ALLEGATIONS

19. The '091 and '058 Patents generally describe acoustic noise suppression with a voice activity detector that senses vibration in human tissue associated with voicing activity. The technology of the '091 Patent was developed by Dr. Gregory C. Burnett and Eric F. Breitfeller. The technology of the '058 Patent was developed by Dr. Gregory C. Burnett. The '091 and '058 Patents also describe techniques for generating transfer functions and cross-correlations representative of acoustic signals when voicing activity is absent, providing improved noise suppression. Some embodiments of the inventions include a microphone array with one microphone which primarily captures sound (*e.g.*, speech), and one which primarily captures unwanted noise, both of which provide signals to a noise removal algorithm.

20. The noise removal algorithm may also receive physiological information from a voice activity detector (*e.g.*, an accelerometer) to detect when a user is speaking. Such a voice activity detection signal may be assumed to be perfectly accurate, yielding substantial improvements when applied to the noise removal algorithm. For example, the noise removal algorithm may remove noise by calculating one transfer function when the system is certain that only noise is being received, and another transfer function when the system is certain that speech is being produced. The noise removal algorithm may further improve noise suppression in situations with multiple noise sources by combining such transfer functions into additional transfer functions representative of a ratio of energies received at different microphones. By taking advantage of perfect voice activity detection and transfer functions representative of a ratio of energies received at different microphones, the noise removal algorithm may effectively remove noise from a signal no matter how many noise sources are present. The invention thereby provides

significant advantages for noise suppression systems, particularly in detecting, transmitting, or recording speech.

21. HTC makes, uses, sells, offers to sell, and imports into the United States, products that infringe the '091 and '058 Patents. For example, noise suppression techniques are incorporated into HTC products with voice activity detection devices including, but not limited to, HTC virtual reality headsets, home devices, and smartphones. For example, this functionality is included and utilized in the HTC VIVE Focus 3. The HTC VIVE Focus 3 includes an accelerometer and voice pickup unit which, upon information and belief, comprise a voice activity detector. The HTC VIVE Focus 3 further comprises an array of beamforming microphones which, upon information and belief, generates transfer functions representative of a ratio of energy of the acoustic signals received at each microphone.

22. The '080 Patent generally describes noise suppression with an array of omnidirectional microphones that form virtual microphones with a similar noise response and a dissimilar speech response. The technology of the '080 Patent was developed by Dr. Gregory C. Burnett. The '080 Patent also describes a dual omnidirectional microphone array that forms two distinct virtual microphones that can be paired with an adaptive filter and/or VAD algorithm to significantly reduce noise without distorting speech, thereby improving the signal-to-noise ratio of the desired speech. In some embodiments, output of each physical microphone can be delayed, multiplied by a gain, and summed with the other in order to form at least one virtual microphone, which may be paired with an adaptive filter and/or VAD algorithm to suppress noise. The invention of the '080 Patent provides substantial advantages for noise suppression systems, particularly in detecting, transmitting, or recording speech.

23. HTC makes, uses, sells, offers to sell, and imports into the United States, products that infringe the '080 Patent. For example, this functionality is included and utilized in HTC products with omnidirectional physical MEMS microphones which form virtual beamformed microphones including, but not limited to, HTC virtual reality headsets, home devices, and smartphones. For example, upon information and belief, the HTC VIVE Focus 3 comprises two physical omnidirectional microphones and a processing component coupled to the microphone array generating two beamformed virtual microphones. On information and belief, the processing component generates beamformed microphones with different first and second combinations of output signals from the physical microphone array, wherein the virtual microphones have a similar noise response and a dissimilar speech response.

24. The '357 and '691 Patents generally describe acoustic noise suppression with an array of physical microphones which forms an array of virtual microphones. The technology was developed by Dr. Gregory C. Burnett. The '357 and '691 Patents also describe noise suppression with physical omnidirectional microphones and virtual directional microphones. The physical and/or virtual microphone signals may be combined by filtering and summing in the time domain to apply a varying linear transfer function, suppressing noise in the output signal. The invention provides significant advantages for noise suppression systems, particularly in detecting, transmitting, or recording speech.

25. HTC makes, uses, sells, offers to sell, and imports into the United States, products that infringe the '357 and '691 Patents. For example, this functionality is included and utilized in HTC products with physical MEMS microphones which form virtual beamformed microphones including, but not limited to, HTC e virtual reality headsets, home devices, and smartphones. For example, upon information and belief, the HTC VIVE Focus 3 comprises arrays of physical

microphones, the outputs of which are combined into beamformed microphones to reduce the noise of a signal. On information and belief, the HTC VIVE Focus 3 combines the outputs of the signals generated by the beamforming microphone array to further reduce noise.

26. The '543 Patent generally describes communications systems comprising a voice detection subsystem and a denoising subsystem. The technology of the '543 Patent was developed by Dr. Gregory C. Burnett, Nicholas Petit, Alexander M. Asseily, and Andrew E. Einaudi. The '543 Patent also describes microphone configurations wherein a first microphone is oriented toward a talker's mouth, and a second microphone is oriented away from a talker's mouth, such that the denoising subsystem may subtract noise associated with noise from an acoustic signal that includes speech and noise. In some embodiments of the invention, the denoising system selects a denoising method appropriate to data of at least one frequency sub-band of acoustic signals, generates noise waveform estimate, and subtracts the noise waveform estimate from signals including speech and noise when the voice detection subsystem indicates voicing activity is occurring. The invention provides significant advantages for noise suppression systems, particularly in detecting, transmitting, or recording speech.

27. HTC makes, uses, sells, offers to sell, and imports into the United States, products that infringe the '543 Patent. For example, noise suppression techniques are incorporated into HTC products with voice activity detection devices including, but not limited to, HTC virtual reality headsets, home devices, and smartphones. For example, this functionality is included and utilized in the HTC VIVE Focus 3. For example, upon information and belief, the HTC VIVE Focus 3 comprises arrays of physical microphones and beamformed microphones, the outputs of which are combined to reduce the noise of a signal. At least one microphone of the HTC VIVE Focus 3 (e.g., the lower microphone) is oriented towards a user's mouth, while at least one

microphone is oriented away from a user’s mouth. On information and belief, the accelerometers and/or voice pickup unit sensors of the Accused Products detect vibration in human tissue and work in tandem with beamforming microphones to suppress noise.

Top view

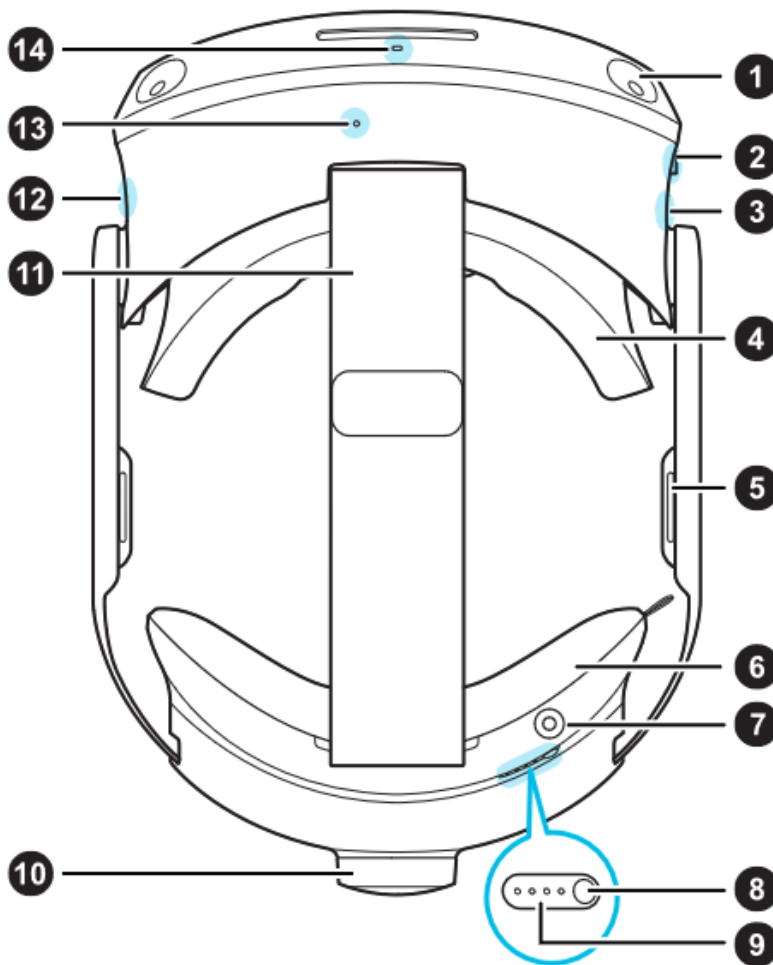

1	Headset camera (4x)
2	3.5mm audio jack
3	USB Type-C® port
4	Face cushion and frame
5	Built-in speaker
6	Back pad
7	Charging port
8	Power button
9	Battery LEDs
10	Adjustment dial
11	Headset strap
12	Headset button
13	Microphone
14	Headset LED

Bottom view

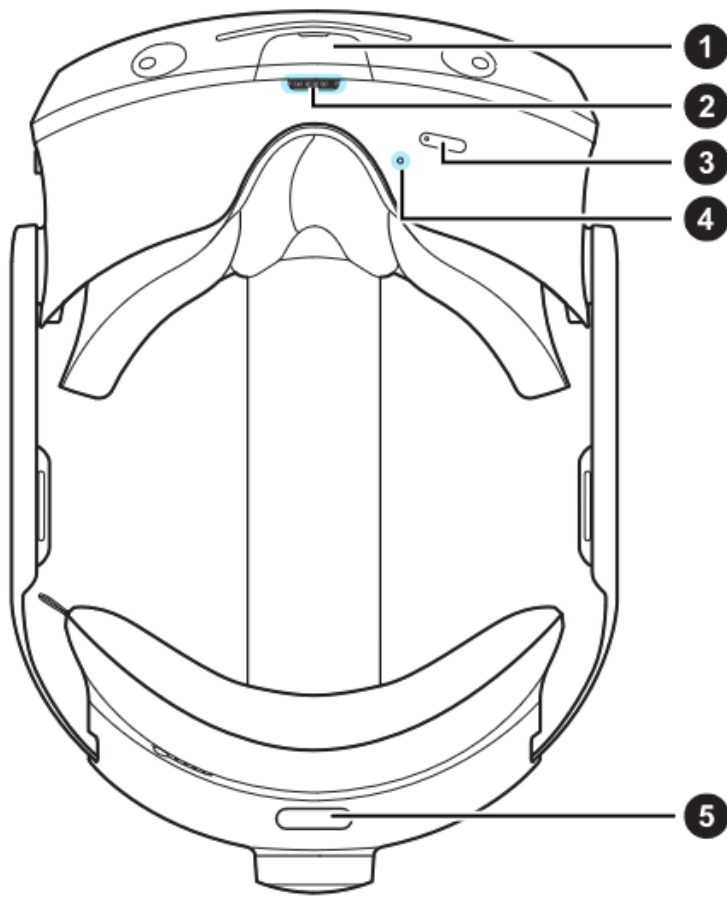

1	USB Type-C port (remove cover)
2	IPD dial
3	Volume buttons
4	Microphone
5	Quick adjustment button

2

² https://dl4.htc.com/Web_materials/Manual/Vive_Focus3/VIVE_FOCUS3_UG.pdf

Sensors

4x Tracking cameras

G-sensor

Gyroscope

Proximity sensor

3

28. The '611 and '213 Patents generally describe acoustic voice activity detection based on a ratio of energies between virtual microphones formed by an array of physical microphones. The technology of the '611 and '213 Patents was developed by Dr. Gregory C. Burnett, Nicholas Petit, and Zhinian Jing. In some embodiments of the invention, a first virtual microphone may be generated by summing the outputs of a first physical microphone processed with a delay filter, and a second physical microphone processed with a calibration filter and an adaptive filter, while a second virtual microphone may be generated by summing the outputs of a first physical microphone processed with an adaptive filter and a delay filter, and a second physical microphone processed with a calibration filter. Accordingly, the invention provides virtual microphones with similar noise response magnitudes, but very dissimilar speech response magnitudes. A ratio of energies between the virtual microphones may further be compared to a threshold to detect when voicing activity is occurring. The invention of the '611 and '213 Patents provides significant improvements in noise suppression, including by enabling accurate voice activity detection with a microphone array.

³ <https://www.vive.com/us/product/vive-focus3/specs/>

29. HTC makes, uses, sells, offers to sell, and imports into the United States, products that infringe the '213 and '611 Patents. For example, this functionality is included and utilized in HTC products which use virtual microphones formed by physical microphones to detect a wake word including, but not limited to, HTC virtual reality headsets, home devices, and smartphones. For example, upon information and belief, the HTC VIVE Focus 3 forms an array of virtual microphones, such as by implementing a form of filter-and-sum beamforming. Upon information and belief, the HTC VIVE Focus 3 detects user speech, such as a wake word, by comparing a ratio of energies (*e.g.*, amplitudes), of the beamformed microphones to a threshold.

30. Jawbone has at all times complied with the marking provisions of 35 U.S.C. § 287 with respect to the Patents-in-Suit. On information and belief, prior assignees and licensees have also complied with the marking provisions of 35 U.S.C. § 287.

31. HTC has infringed and is continuing to infringe the '091, '058, '080, '357, '543, '691, '213, and '611 Patents by making, using, selling, offering to sell, and/or importing, and by actively inducing others to make, use, sell, offer to sell, and/or import, Accused Products that comprise and utilize infringing noise cancellation features. On information and belief, the Accused Products include, but are not limited to, at least all versions and variants of HTC virtual reality headsets (*e.g.*, VIVE XR Elite, VIVE Flow, VIVE Pro, VIVE Pro2, VIVE Pro Eye, VIVE Cosmos, VIVE Focus 3, VIVE Focus Plus, etc.), HTC home devices (*e.g.*, HTC 5G Hub, etc.), and HTC smartphones (*e.g.*, Exodus 1, Exodus 1 Binance, Exodus 1s, HTC U12+, HTC U11, HTC U11 life, HTC U Ultra, HTC U19e, HTC U20 5G, HTC Desire 20 Pro, HTC Desire 20+, HTC Desire 21 Pro 5G, etc.).

COUNT I
(Infringement of the '091 Patent)

32. Paragraphs 1 through 31 are incorporated by reference as if fully set forth herein.

33. Jawbone has not licensed or otherwise authorized HTC to make, use, sell, offer to sell, and/or import any products that embody the inventions of the '091 Patent.

34. HTC has and continues to directly infringe the '091 Patent, either literally or under the doctrine of equivalents, without authority and in violation of 35 U.S.C. § 271, by making, using, selling, offering to sell, and/or importing into the United States products that satisfy each and every limitation of one or more claims of the '091 Patent. Upon information and belief, these products include at least the Accused Products, such as those which comprise a microphone array and a voice activity detector. The Accused Products include at least all versions and variants of HTC virtual reality headsets (*e.g.*, VIVE XR Elite, VIVE Flow, VIVE Pro, VIVE Pro2, VIVE Pro Eye, VIVE Cosmos, VIVE Focus 3, VIVE Focus Plus, etc.), HTC home devices (*e.g.*, HTC 5G Hub, etc.), and HTC smartphones (*e.g.*, Exodus 1, Exodus 1 Binance, Exodus 1s, HTC U12+, HTC U11, HTC U11 life, HTC U Ultra, HTC U19e, HTC U20 5G, HTC Desire 20 Pro, HTC Desire 20+, HTC Desire 21 Pro 5G, etc.).

35. For example, HTC has and continues to directly infringe at least claim 11 of the '091 Patent by making, using, selling, offering to sell, and/or importing into the United States products that comprise a system for removing acoustic noise from the acoustic signals, comprising: a receiver that receives at least two acoustic signals via at least two acoustic microphones positioned in a plurality of locations; at least one sensor that receives human tissue vibration information associated with human voicing activity of a user; a processor coupled among the receiver and the at least one sensor that generates a plurality of transfer functions, wherein the plurality of transfer functions includes a first transfer function representative of a ratio of energy of acoustic signals received using at least two different acoustic microphones of the at least two acoustic microphones, wherein the first transfer function is generated in response to a

determination that voicing activity is absent from the acoustic signals for a period of time, wherein the plurality of transfer functions includes a second transfer function representative of the acoustic signals, wherein the second transfer function is generated in response to a determination that voicing activity is present in the acoustic signals for the period of time, wherein acoustic noise is removed from the acoustic signals using the first transfer function and at least one combination of the first transfer function and the second transfer function to produce the denoised acoustic data stream.

Processor

Qualcomm® Snapdragon™ XR2

4

36. The Accused Products comprise a system for removing acoustic noise from acoustic signals. For example, upon information and belief, the HTC VIVE Focus 3 receives acoustic signals from a microphone array.⁵

37. The Accused Products further comprise a receiver that receives at least two acoustic signals via at least two acoustic microphones positioned in a plurality of locations. For example, upon information and belief, the HTC VIVE Focus 3 comprises a receiver that receives signals via a microphone array, with at least two microphones positioned in a plurality of locations.

⁴ <https://www.vive.com/us/product/vive-focus3/specs/>

⁵ <https://www.vive.com/us/product/vive-focus3/specs/>

Top view

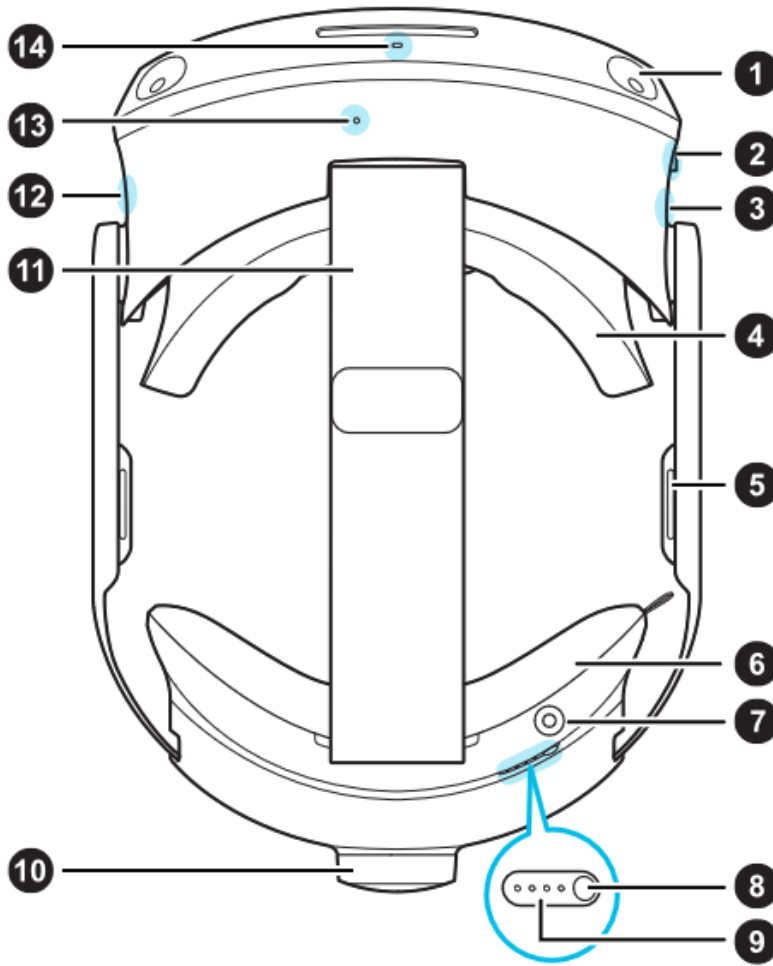

1	Headset camera (4x)
2	3.5mm audio jack
3	USB Type-C® port
4	Face cushion and frame
5	Built-in speaker
6	Back pad
7	Charging port
8	Power button
9	Battery LEDs
10	Adjustment dial
11	Headset strap
12	Headset button
13	Microphone
14	Headset LED

Bottom view

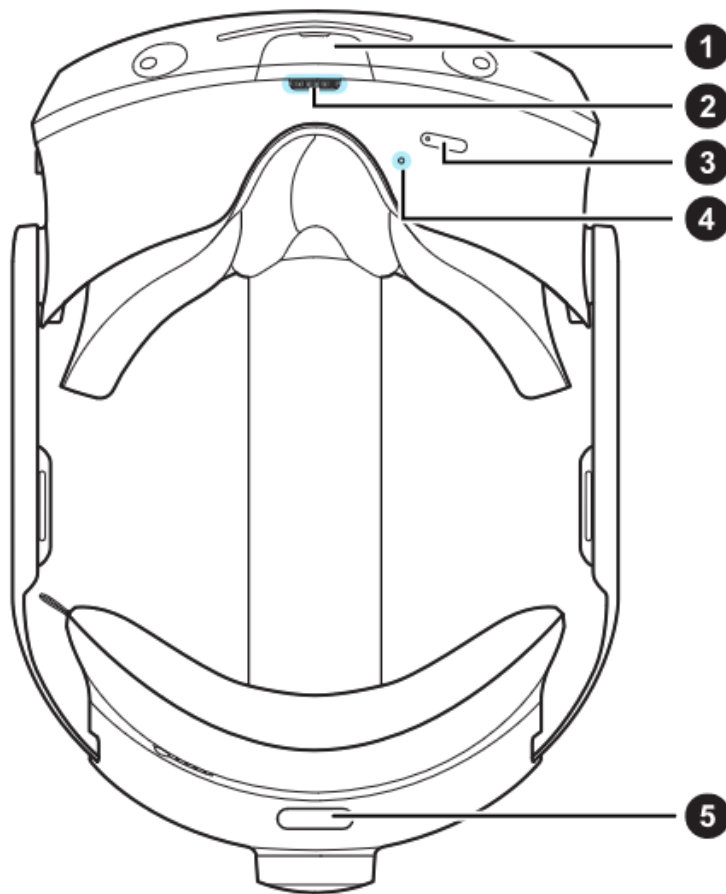

1	USB Type-C port (remove cover)
2	IPD dial
3	Volume buttons
4	Microphone
5	Quick adjustment button

6

38. The Accused Products further comprise at least one sensor that receives human tissue vibration information associated with human voicing activity of a user. For example, the HTC VIVE Focus 3 comprises an at least one accelerometer and voice pickup unit sensor which, upon information and belief, receives human tissue vibration associated with voicing activity.⁷

⁶ https://dl4.htc.com/Web_materials/Manual/Vive_Focus3/VIVE_FOCUS3_UG.pdf

⁷ <https://www.vive.com/us/product/vive-focus3/specs/>

Upon information and belief, the voice pickup unit of the HTC VIVE Focus 3 comprises the voice detecting accelerometer and/or sensor.

39. The Accused Products further comprise a processor coupled among the receiver and the at least one sensor that generates a plurality of transfer functions, wherein the plurality of transfer functions includes a first transfer function representative of a ratio of energy of acoustic signals received using at least two different acoustic microphones of the at least two acoustic microphones. Upon information and belief, HTC's processor utilizes a microphone array to detect speech with a beamformed microphone which, upon information and belief, includes the generation of at least a plurality of transfer functions, including a first transfer function representative of a ratio of energy of acoustic signals received at different microphones in the microphone array.

40. The Accused Products further comprise a system wherein the first transfer function is generated in response to a determination that voicing activity is absent from the acoustic signals for a period of time. For example, upon information and belief, the HTC VIVE Focus 3 generates the first transfer function when a voice pickup unit, accelerometer, and/or sensor indicate that voicing activity is absent.

41. The Accused Products further comprise a system wherein the plurality of transfer functions includes a second transfer function representative of the acoustic signals, wherein the second transfer function is generated in response to a determination that voicing activity is present in the acoustic signals for the period of time. For example, upon information and belief, the HTC VIVE Focus 3 generates a second transfer function in response to a determination that voicing activity is present, such as based on detection of human tissue vibrations by the voice pickup unit, accelerometer, and/or sensor.

42. The Accused Products further comprise a system wherein acoustic noise is removed from the acoustic signals using the first transfer function and at least one combination of the first transfer function and the second transfer function to produce the denoised acoustic data stream. For example, upon information and belief, the HTC VIVE Focus 3 removes noise from acoustic signals by applying at least a first transfer function generated when voicing activity is absent, and a transfer function generated by combining the first transfer function generated when voicing activity is absent and a second transfer function generated when voicing activity is detected. For example, upon information and belief, the HTC VIVE Focus 3 utilizes a least mean squares method to suppress acoustic noise.

43. HTC has and continues to indirectly infringe one or more claims of the '091 Patent by knowingly and intentionally inducing others, including HTC customers and end-users of the Accused Products and products that include the Accused Products, to directly infringe, either literally or under the doctrine of equivalents, by making, using, selling, offering to sell, and/or importing into the United States products that include infringing technology, such as the HTC VIVE Focus 3.

44. HTC, with knowledge that these products, or the use thereof, infringe the '091 Patent since at least 2017 but by no later than the date of this Complaint, knowingly and intentionally induced, and continues to knowingly and intentionally induce, direct infringement of the '091 Patent by providing these products to customers and/or distributors for use in an infringing manner in the United States including, but not limited to, products that include infringing technology, such as the HTC VIVE Focus 3. For example, HTC's instruction manuals, websites, promotional materials, advertisements, and other information demonstrate to others, including customers, prospective customers, and distributors, how to use the Accused Products in an

infringing manner. Upon information and belief, HTC is aware that the normal and customary use of the Accused Products by customers, distributors, and others would infringe the '091 Patent.

45. HTC has induced infringement by others, including customers and distributors, with the intent to cause infringing acts by others or, in the alternative, with the belief that there was a high probability that others, including end-users, infringe the '091 Patent, but while remaining willfully blind to the infringement.

46. HTC has willfully infringed, and continues to willfully infringe, the '091 Patent by intentionally and deliberately carrying out acts of direct and indirect infringement, while knowing or taking deliberate steps to avoid learning, that those acts infringe. For example, upon information and belief, HTC has known of Jawbone's patents, including the '091 Patent, at least since they were marketed to HTC following Jawbone, Inc.'s liquidation.

47. Jawbone has suffered damages as a result of HTC's direct and indirect infringement and willful infringement of the '091 Patent in an amount to be proved at trial.

48. Jawbone has suffered, and will continue to suffer, irreparable harm as a result of HTC's infringement of the '091 Patent for which there is no adequate remedy at law, unless HTC's infringement is enjoined by this Court. Accordingly, Jawbone seeks a preliminary and permanent injunction enjoining HTC from making, using, selling, offering to sell, and/or importing the Accused Products, including at least all versions and variants of HTC virtual reality headsets (*e.g.*, VIVE XR Elite, VIVE Flow, VIVE Pro, VIVE Pro2, VIVE Pro Eye, VIVE Cosmos, VIVE Focus 3, VIVE Focus Plus, etc.), HTC home devices (*e.g.*, HTC 5G Hub, etc.), and HTC smartphones (*e.g.*, Exodus 1, Exodus 1 Binance, Exodus 1s, HTC U12+, HTC U11, HTC U11 life, HTC U Ultra, HTC U19e, HTC U20 5G, HTC Desire 20 Pro, HTC Desire 20+, HTC Desire 21 Pro 5G, etc.).

COUNT II
(Infringement of the '058 Patent)

49. Paragraphs 1 through 31 are incorporated by reference as if fully set forth herein.

50. Jawbone has not licensed or otherwise authorized HTC to make, use, sell, offer to sell, and/or import any products that embody the inventions of the '058 Patent.

51. HTC has and continues to directly infringe the '058 Patent, either literally or under the doctrine of equivalents, without authority and in violation of 35 U.S.C. § 271, by making, using, selling, offering to sell, and/or importing into the United States products that satisfy each and every limitation of one or more claims of the '058 Patent. Upon information and belief, these products include at least the Accused Products, such as those which comprise a microphone array and a voice activity detector. The Accused Products include at least all versions and variants of HTC virtual reality headsets (*e.g.*, VIVE XR Elite, VIVE Flow, VIVE Pro, VIVE Pro2, VIVE Pro Eye, VIVE Cosmos, VIVE Focus 3, VIVE Focus Plus, etc.), HTC home devices (*e.g.*, HTC 5G Hub, etc.), and HTC smartphones (*e.g.*, Exodus 1, Exodus 1 Binance, Exodus 1s, HTC U12+, HTC U11, HTC U11 life, HTC U Ultra, HTC U19e, HTC U20 5G, HTC Desire 20 Pro, HTC Desire 20+, HTC Desire 21 Pro 5G, etc.).

52. For example, HTC has and continues to directly infringe at least claim 1 of the '058 Patent by making, using, selling, offering to sell, and/or importing into the United States products that comprise a system for detecting voiced and unvoiced speech in acoustic signals having varying levels of background noise, comprising: at least two microphones that receive the acoustic signals; at least one voicing sensor that receives physiological information associated with human voicing activity; and at least one processor coupled among the microphones and the voicing sensor, wherein the at least one processor; generates cross correlation data between the physiological information and an acoustic signal received at one of the two microphones; identifies information

of the acoustic signals as voiced speech when the cross correlation data corresponding to a portion of the acoustic signal received at the one receiver exceeds a correlation threshold; generates difference parameters between the acoustic signals received at each of the two receivers, wherein the difference parameters are representative of the relative difference in signal gain between portions of the received acoustic signals; identifies information of the acoustic signals as unvoiced speech when the difference parameters exceed a gain threshold; and identifies information of the acoustic signals as noise when the difference parameters are less than the gain threshold.

53. The Accused Products comprise at least two microphones that receive acoustic signals. For example, the HTC VIVE Focus 3 comprises at least two MEMS microphones that receive acoustic signals.

Top view

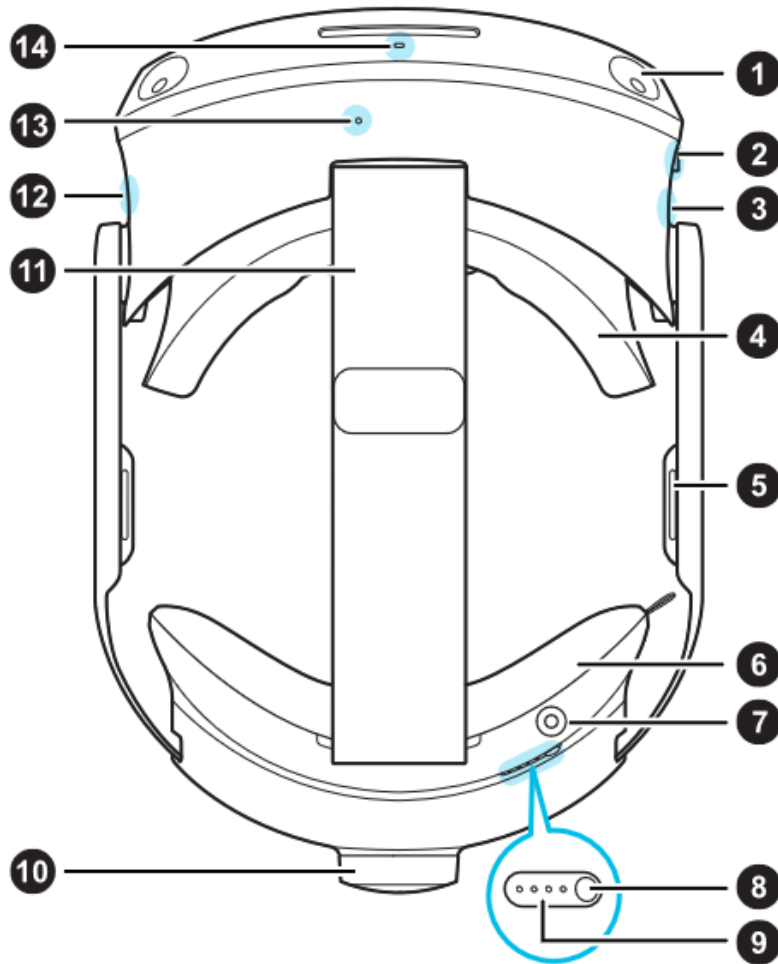

1	Headset camera (4x)
2	3.5mm audio jack
3	USB Type-C® port
4	Face cushion and frame
5	Built-in speaker
6	Back pad
7	Charging port
8	Power button
9	Battery LEDs
10	Adjustment dial
11	Headset strap
12	Headset button
13	Microphone
14	Headset LED

54.

Bottom view

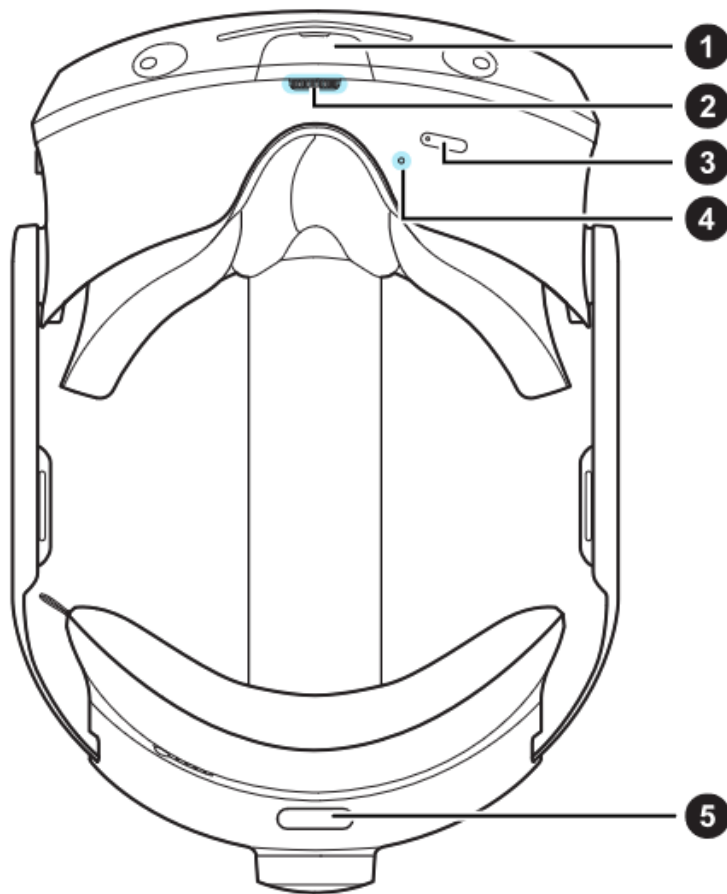

1	USB Type-C port (remove cover)
2	IPD dial
3	Volume buttons
4	Microphone
5	Quick adjustment button

8

55. The Accused Products further comprise at least one voicing sensor that receives physiological information associated with human voicing activity. For example, the HTC VIVE Focus 3 comprises an accelerometer which, upon information and belief, receives human tissue vibration associated with voicing activity.

56. The Accused Products further comprise at least one processor coupled among the microphones and the voicing sensor. For example, upon information and belief, the HTC VIVE Focus 3 comprises a processor coupled between the microphones and accelerometers.

⁸ https://dl4.htc.com/Web_materials/Manual/Vive_Focus3/VIVE_FOCUS3_UG.pdf

Processor

Qualcomm® Snapdragon™ XR2

9

57. The Accused Products further comprise a processor which generates cross correlation data between the physiological information and an acoustic signal received at one of the two microphones. For example, upon information and belief, the processor of the HTC VIVE Focus 3 generates cross correlation data between the physiological information (*e.g.*, tissue vibration) and an acoustic signal received at one of the two microphones (*e.g.*, an acoustic signal including speech).

58. The Accused Products further comprise a processor which identifies information of the acoustic signals as voiced speech when the cross correlation data corresponding to a portion of the acoustic signal received at the one receiver exceeds a correlation threshold. For example, upon information and belief, the processor of the HTC VIVE Focus 3 identifies the acoustic signals as speech when the cross correlation data corresponding to a portion of the acoustic signal received at the microphone exceeds a correlation threshold (*e.g.*, a threshold based on vibration and/or acoustic signals).

59. The Accused Products further comprise a processor which generates difference parameters between the acoustic signals received at each of the two receivers, wherein the difference parameters are representative of the relative difference in signal gain between portions of the received acoustic signals. For example, upon information and belief, the processor of the

⁹ <https://www.vive.com/us/product/vive-focus3/specs/>

HTC VIVE Focus 3 generates difference parameters between the acoustic signals received at each MEMS microphone representative of the relative difference in signal gain between portions of the received acoustic signals.

60. The Accused Products further comprise a processor which identifies information of the acoustic signals as unvoiced speech when the difference parameters exceed a gain threshold. For example, the processor of the HTC VIVE Focus 3 identifies information of the acoustic signals as unvoiced speech (*e.g.*, speech which normally does not cause significant vibration in human tissue) when the difference parameter exceeds a gain threshold.

61. The Accused Products further comprise a processor which identifies information of the acoustic signals as noise when the difference parameters are less than the gain threshold. For example, the processor of the HTC VIVE Focus 3 identifies acoustic signals as noise (*e.g.*, unwanted background noise) when the difference parameters are less than the gain threshold.

62. HTC has and continues to indirectly infringe one or more claims of the '058 Patent by knowingly and intentionally inducing others, including HTC's customers and end-users of the Accused Products, to directly infringe, either literally or under the doctrine of equivalents, by making, using, selling, offering to sell, and/or importing into the United States products that include infringing technology, such as the HTC VIVE Focus 3.

63. HTC, with knowledge that these products, or the use thereof, infringe the '058 Patent since at least 2017 but by no later than the date of this Complaint, knowingly and intentionally induced, and continues to knowingly and intentionally induce, direct infringement of the '058 Patent by providing these products to customers and ultimately to end-users for use in an infringing manner in the United States including, but not limited to, products that include infringing technology, such as the HTC VIVE Focus 3. For example, HTC's instruction manuals,

websites, promotional materials, advertisements, and other information demonstrate to others, including customers, prospective customers, and distributors, how to use the Accused Products in an infringing manner. Upon information and belief, HTC is aware that the normal and customary use of the Accused Products by customers, distributors, and others would infringe the Asserted Patents.

64. HTC has induced infringement by others, including end-users, with the intent to cause infringing acts by others or, in the alternative, with the belief that there was a high probability that others, including end-users, infringe the '058 Patent, but while remaining willfully blind to the infringement.

65. HTC has willfully infringed, and continues to willfully infringe, the '058 Patent by intentionally and deliberately carrying out acts of direct and indirect infringement, while knowing or taking deliberate steps to avoid learning that those acts infringe. For example, upon information and belief, HTC has known of Jawbone's patents, including the '058 Patent, at least since they were marketed to HTC following Jawbone, Inc.'s liquidation.

66. Jawbone has suffered damages as a result of HTC's direct and indirect infringement and willful infringement of the '058 Patent in an amount to be proved at trial.

67. Jawbone has suffered, and will continue to suffer, irreparable harm as a result of HTC's infringement of the '058 Patent for which there is no adequate remedy at law, unless HTC's infringement is enjoined by this Court. Accordingly, Jawbone seeks a preliminary and permanent injunction enjoining HTC from making, using, importing, selling, offering to sell, and/or importing the Accused Products, including at least all versions and variants of HTC virtual reality headsets (*e.g.*, VIVE XR Elite, VIVE Flow, VIVE Pro, VIVE Pro2, VIVE Pro Eye, VIVE Cosmos, VIVE Focus 3, VIVE Focus Plus, etc.), HTC home devices (*e.g.*, HTC 5G Hub, etc.), and HTC

smartphones (*e.g.*, Exodus 1, Exodus 1 Binance, Exodus 1s, HTC U12+, HTC U11, HTC U11 life, HTC U Ultra, HTC U19e, HTC U20 5G, HTC Desire 20 Pro, HTC Desire 20+, HTC Desire 21 Pro 5G, etc.).

COUNT III
(Infringement of the '080 Patent)

68. Paragraphs 1 through 31 are incorporated by reference as if fully set forth herein.

69. Jawbone has not licensed or otherwise authorized HTC to make, use, sell, offer to sell, and/or import any products that embody the inventions of the '080 Patent.

70. HTC has and continues to directly infringe the '080 Patent, either literally or under the doctrine of equivalents, without authority and in violation of 35 U.S.C. § 271, by making, using, selling, offering to sell, and/or importing into the United States products that satisfy each and every limitation of one or more claims of the '080 Patent. Upon information and belief, these products include at least the Accused Products, such as those which comprise an array of physical and virtual microphones and suppress noise from received signals. The Accused Products include at least all versions and variants of HTC virtual reality headsets (*e.g.*, VIVE XR Elite, VIVE Flow, VIVE Pro, VIVE Pro2, VIVE Pro Eye, VIVE Cosmos, VIVE Focus 3, VIVE Focus Plus, etc.), HTC home devices (*e.g.*, HTC 5G Hub, etc.), and HTC smartphones (*e.g.*, Exodus 1, Exodus 1 Binance, Exodus 1s, HTC U12+, HTC U11, HTC U11 life, HTC U Ultra, HTC U19e, HTC U20 5G, HTC Desire 20 Pro, HTC Desire 20+, HTC Desire 21 Pro 5G, etc.).

71. For example, HTC has and continues to directly infringe at least claim 1 of the '080 Patent by making, using, selling, offering to sell, and/or importing into the United States, a system comprising: a microphone array including a first physical microphone outputting a first microphone signal and a second physical microphone outputting a second microphone signal; a processing component coupled to the microphone array and generating a virtual microphone array

including a first virtual microphone and a second virtual microphone, the first virtual microphone including a first combination of the first microphone signal and the second microphone signal, the second virtual microphone including a second combination of the first microphone signal and the second microphone signal, wherein the second combination is different from the first combination, wherein the first virtual microphone and the second virtual microphone have substantially similar responses to noise and substantially dissimilar responses to speech; and an adaptive noise removal application coupled to the processing component and generating denoised output signals by forming a plurality of combinations of signals output from the first virtual microphone and the second virtual microphone, by filtering and summing the plurality of combinations of signals in the time domain, and by a varying linear transfer function between the plurality of combinations of signals, wherein the denoised output signals include less acoustic noise than acoustic signals received at the microphone array.

72. Each Accused Product comprises a microphone array including a first physical microphone outputting a first microphone signal and a second physical microphone outputting a second microphone signal. For example, upon information and belief, the HTC VIVE Focus 3 comprises at least two outward facing microphones, each of which outputs a microphone signal.

73. Each Accused Product comprises a processing component coupled to the microphone array and generating a virtual microphone array including a first virtual microphone and a second virtual microphone. For example, the HTC VIVE Focus 3 comprises a processor and/or other DSP that is coupled to the microphone array and, upon information and belief, generates at least two beamformed microphones.

74. Each Accused Product comprises a system wherein the first virtual microphone including a first combination of the first microphone signal and the second microphone signal, the

second virtual microphone including a second combination of the first microphone signal and the second microphone signal, wherein the second combination is different from the first combination. For example, upon information and belief, each beamformed microphone of the HTC VIVE Focus 3 includes a different combination of signals from its respective physical microphones.

75. Each Accused Product comprises a system wherein the first virtual microphone and the second virtual microphone have substantially similar responses to noise and substantially dissimilar responses to speech. For example, upon information and belief, the beamformed microphones of the HTC VIVE Focus 3 each have a substantially similar response to noise and a substantially dissimilar response to speech.

76. Each Accused Product comprises an adaptive noise removal application coupled to the processing component and generating denoised output signals by forming a plurality of combinations of signals output from the first virtual microphone and the second virtual microphone, by filtering and summing the plurality of combinations of signals in the time domain, and by a varying linear transfer function between the plurality of combinations of signals. For example, upon information and belief, the HTC VIVE Focus 3 comprises an adaptive noise removal application coupled to a processor and/or other DSP, which generates denoised output signals by forming at least two combinations of signals from the beamformed microphones, by filtering and summing those combinations in the time domain, and by varying a linear transfer function between those combinations of signals.

77. Each Accused Product comprises a system wherein the denoised output signals include less acoustic noise than acoustic signals received at the microphone array. For example, upon information and belief, the signals denoised by the adaptive noise removal application of the

HTC VIVE Focus 3 each include less noise than the acoustic signals received at their respective microphones.

78. HTC has and continues to indirectly infringe one or more claims of the '080 Patent by knowingly and intentionally inducing others, including HTC customers and end-users of the Accused Products, to directly infringe, either literally or under the doctrine of equivalents, by making, using, selling, offering to sell, and/or importing into the United States products that include infringing technology, such as the HTC VIVE Focus 3.

79. HTC, with knowledge that these products, or the use thereof, infringe the '080 Patent at least as of the date of this Complaint, knowingly and intentionally induced, and continues to knowingly and intentionally induce, direct infringement of the '080 Patent by providing these products to customers and ultimately to end-users for use in an infringing manner in the United States including, but not limited to, products that include infringing technology, such as the HTC VIVE Focus 3. For example, HTC's instruction manuals, websites, promotional materials, advertisements, and other information demonstrate to others, including customers, prospective customers, and distributors, how to use the Accused Products in an infringing manner. Upon information and belief, HTC is aware that the normal and customary use of the Accused Products by customers, distributors, and others would infringe the '080 Patent.

80. HTC has induced infringement by others, including end-users, with the intent to cause infringing acts by others or, in the alternative, with the belief that there was a high probability that others, including end-users, infringe the '080 Patent.

81. Jawbone has suffered damages as a result of HTC's direct and indirect infringement of the '080 Patent in an amount to be proved at trial.

82. Jawbone has suffered, and will continue to suffer, irreparable harm as a result of HTC's infringement of the '080 Patent for which there is no adequate remedy at law, unless HTC's infringement is enjoined by this Court. Accordingly, Jawbone seeks a preliminary and permanent injunction enjoining HTC from making, using, selling, offering to sell, and/or importing the Accused Products, including at least all versions and variants of HTC virtual reality headsets (*e.g.*, VIVE XR Elite, VIVE Flow, VIVE Pro, VIVE Pro2, VIVE Pro Eye, VIVE Cosmos, VIVE Focus 3, VIVE Focus Plus, etc.), HTC home devices (*e.g.*, HTC 5G Hub, etc.), and HTC smartphones (*e.g.*, Exodus 1, Exodus 1 Binance, Exodus 1s, HTC U12+, HTC U11, HTC U11 life, HTC U Ultra, HTC U19e, HTC U20 5G, HTC Desire 20 Pro, HTC Desire 20+, HTC Desire 21 Pro 5G, etc.).

COUNT IV
(Infringement of the '357 Patent)

83. Paragraphs 1 through 31 are incorporated by reference as if fully set forth herein.

84. Jawbone has not licensed or otherwise authorized HTC to make, use, sell, offer to sell, and/or import any products that embody the inventions of the '357 Patent.

85. HTC has and continues to directly infringe the '357 Patent, either literally or under the doctrine of equivalents, without authority and in violation of 35 U.S.C. § 271, by making, using, selling, offering to sell, and/or importing into the United States products that satisfy each and every limitation of one or more claims of the '357 Patent. Upon information and belief, these products include at least the Accused Products, such as those which comprise physical and virtual microphone arrays. The Accused Products include at least all versions and variants of HTC virtual reality headsets (*e.g.*, VIVE XR Elite, VIVE Flow, VIVE Pro, VIVE Pro2, VIVE Pro Eye, VIVE Cosmos, VIVE Focus 3, VIVE Focus Plus, etc.), HTC home devices (*e.g.*, HTC 5G Hub, etc.), and HTC smartphones (*e.g.*, Exodus 1, Exodus 1 Binance, Exodus 1s, HTC U12+, HTC U11, HTC

U11 life, HTC U Ultra, HTC U19e, HTC U20 5G, HTC Desire 20 Pro, HTC Desire 20+, HTC Desire 21 Pro 5G, etc.).

86. For example, HTC has and continues to directly infringe at least claim 1 of the '357 Patent by making, using, selling, offering to sell, and/or importing into the United States products comprising a first virtual microphone comprising a first combination of a first microphone signal and a second microphone signal, wherein the first microphone signal is generated by a first physical microphone and the second microphone signal is generated by a second physical microphone; a second virtual microphone comprising a second combination of the first microphone signal and the second microphone signal, wherein the second combination is different from the first combination, wherein the first virtual microphone and the second virtual microphone are distinct virtual directional microphones with substantially similar responses to noise and substantially dissimilar responses to speech; and a signal processor coupled with the first and second microphone signals and operative to combine the first and second microphone signals by filtering and summing in the time domain, to apply a varying linear transfer function between the first and second microphone signals, and to generate an output signal having noise content that is attenuated with respect to speech content.

87. Each Accused Product comprises a first virtual microphone comprising a first combination of a first microphone signal and a second microphone signal, wherein the first microphone signal is generated by a first physical microphone and the second microphone signal is generated by a second physical microphone. For example, upon information and belief, the HTC VIVE Focus 3 comprises at least two physical microphones, and a first beamformed microphone comprising signals generated by both microphones.

88. Each Accused Product comprises a second virtual microphone comprising a second combination of the first microphone signal and the second microphone signal, wherein the second combination is different from the first combination. For example, upon information and belief, the HTC VIVE Focus 3 comprises a second beamformed microphone comprising signals generated by the first and second physical microphones.

89. Each Accused Product comprises a system wherein the first virtual microphone and the second virtual microphone are distinct virtual directional microphones with substantially similar responses to noise and substantially dissimilar responses to speech. For example, upon information and belief, the beamformed microphones of the HTC VIVE Focus 3 have similar noise responses and dissimilar speech responses.

90. Each Accused Product comprises a signal processor coupled with the first and second microphone signals and operative to combine the first and second microphone signals by filtering and summing in the time domain, to apply a varying linear transfer function between the first and second microphone signals, and to generate an output signal having noise content that is attenuated with respect to speech content. For example, upon information and belief, the HTC VIVE Focus 3 comprises a processor and/or other DSP, which generates denoised output signals by forming at least two combinations of signals from the beamformed microphones, by filtering and summing those combinations, and by varying a linear transfer function between those combinations of signals.

91. HTC has and continues to indirectly infringe one or more claims of the '357 Patent by knowingly and intentionally inducing others, including HTC's customers and end-users of the Accused Products, to directly infringe, either literally or under the doctrine of equivalents, by

making, using, selling, offering to sell, and/or importing into the United States products that include infringing technology, such as the HTC VIVE Focus 3.

92. HTC, with knowledge that these products, or the use thereof, infringe the '357 Patent at least as of the date of this Complaint, knowingly and intentionally induced, and continues to knowingly and intentionally induce, direct infringement of the '357 Patent by providing these products to customers and ultimately to end-users for use in an infringing manner in the United States including, but not limited to, products that include infringing technology, such as the HTC VIVE Focus 3. For example, HTC's instruction manuals, websites, promotional materials, advertisements, and other information demonstrate to others, including customers, prospective customers, and distributors, how to use the Accused Products in an infringing manner. Upon information and belief, HTC is aware that the normal and customary use of the Accused Products by customers, distributors, and others would infringe the '357 Patent.

93. HTC has induced infringement by others, including end-users, with the intent to cause infringing acts by others or, in the alternative, with the belief that there was a high probability that others, including end-users, infringe the '357 Patent

94. Jawbone has suffered damages as a result of HTC's direct and indirect infringement of the '357 Patent in an amount to be proved at trial.

95. Jawbone has suffered, and will continue to suffer, irreparable harm as a result of HTC's infringement of the '357 Patent for which there is no adequate remedy at law, unless HTC's infringement is enjoined by this Court. Accordingly, Jawbone seeks a preliminary and permanent injunction enjoining HTC from by making, using, selling, offering to sell, and/or importing the Accused Products, including at least all versions and variants of HTC virtual reality headsets (*e.g.*, VIVE XR Elite, VIVE Flow, VIVE Pro, VIVE Pro2, VIVE Pro Eye, VIVE Cosmos, VIVE Focus

3, VIVE Focus Plus, etc.), HTC home devices (*e.g.*, HTC 5G Hub, etc.), and HTC smartphones (*e.g.*, Exodus 1, Exodus 1 Binance, Exodus 1s, HTC U12+, HTC U11, HTC U11 life, HTC U Ultra, HTC U19e, HTC U20 5G, HTC Desire 20 Pro, HTC Desire 20+, HTC Desire 21 Pro 5G, etc.).

COUNT V
(Infringement of the '543 Patent)

96. Paragraphs 1 through 31 are incorporated by reference as if fully set forth herein.

97. Jawbone has not licensed or otherwise authorized HTC to make, use, sell, offer to sell, and/or import any products that embody the inventions of the '543 Patent.

98. HTC has and continues to directly infringe the '543 Patent, either literally or under the doctrine of equivalents, without authority and in violation of 35 U.S.C. § 271, by making, using, selling, offering to sell, and/or importing into the United States products that satisfy each and every limitation of one or more claims of the '543 Patent. Upon information and belief, these products include at least the Accused Products, such as those which comprise a microphone array and a voice activity detector. The Accused Products include at least all versions and variants of HTC virtual reality headsets (*e.g.*, VIVE XR Elite, VIVE Flow, VIVE Pro, VIVE Pro2, VIVE Pro Eye, VIVE Cosmos, VIVE Focus 3, VIVE Focus Plus, etc.), HTC home devices (*e.g.*, HTC 5G Hub, etc.), and HTC smartphones (*e.g.*, Exodus 1, Exodus 1 Binance, Exodus 1s, HTC U12+, HTC U11, HTC U11 life, HTC U Ultra, HTC U19e, HTC U20 5G, HTC Desire 20 Pro, HTC Desire 20+, HTC Desire 21 Pro 5G, etc.).

99. For example, HTC has and continues to directly infringe at least claim 1 of the '543 Patent by making, using, selling, offering to sell, selling, and/or importing into the United States products that comprise a communications system, comprising: a voice detection subsystem configured to receive voice activity signals that include information associated with human voicing

activity, the voice detection subsystem configured to automatically generate control signals using the voice activity signals; and a denoising subsystem coupled to the voice detection subsystem, the denoising subsystem comprising a microphone array including a plurality of microphones, wherein a first microphone of the array is fixed at a first position relative to a mouth, wherein the first position orients a front of the first microphone towards the mouth, wherein a second microphone of the array is fixed at a second position relative to the mouth, wherein the second position orients a front of the second microphone away from the mouth such that the second position forms an angle relative to the first position, wherein the angle is greater than zero degrees, the microphone array providing acoustic signals of an environment to components of the denoising subsystem, components of the denoising subsystem automatically selecting at least one denoising method appropriate to data of at least one frequency subband of the acoustic signals using the control signals and processing the acoustic signals using the selected denoising method to generate denoised acoustic signals, wherein the denoising method includes generating a noise waveform estimate associated with noise of the acoustic signals and subtracting the noise waveform estimate from the acoustic signal when the acoustic signal includes speech and noise, wherein the voice detection subsystem is configured to receive the voice activity signals using a sensor independent from the microphone array and to output the control signals generated from the voice activity signals to the denoising system, the denoising system configured to use the control signals to denoise the acoustic signals from the microphone array.

100. The Accused Products comprise a voice detection subsystem configured to receive voice activity signals that includes information associated with human voicing activity, the voice detection subsystem configured to automatically generate control signals using the voice activity signals. For example, the HTC VIVE Focus 3 comprises a speech detecting accelerometer which,

upon information and belief, is configured to receive voice activity signals that include information associated with human voicing activity, and to automatically generate control signals using the voice activity signals.

101. The Accused Products further comprise a denoising subsystem coupled to the voice detection subsystem, the denoising subsystem comprising a microphone array including a plurality of microphones. For example, the HTC VIVE Focus 3 includes a denoising system comprising an array of microphones, coupled to the accelerometer (*e.g.*, via a DSP and/or processor).

102. The Accused Products further comprise a system wherein a first microphone of the array is fixed at a first position relative to a mouth, wherein the first position orients a front of the first microphone towards the mouth, wherein a second microphone of the array is fixed at a second position relative to the mouth, wherein the second position orients a front of the second microphone away from the mouth such that the second position forms an angle relative to the first position, wherein the angle is greater than zero degrees. For example, a lower microphone of the HTC VIVE Focus 3 is oriented towards a user's mouth, an upper microphone is oriented away from a user's mouth, and the angle between the orientation of the microphones is greater than zero degrees.

103. The Accused Products further comprise a system wherein the microphone array provides acoustic signals of an environment to components of the denoising subsystem. For example, the microphone arrays of the HTC VIVE Focus 3 provide acoustic signals of an environment (*e.g.*, environmental noise) to components of the denoising subsystem (*e.g.*, a DSP and/or processor).

104. The Accused Products further comprise a system wherein components of the denoising subsystem automatically select at least one denoising method appropriate to data of at

least one frequency subband of the acoustic signals using the control signals and processing the acoustic signals using the selected denoising method to generate denoised acoustic signals. For example, upon information and belief, the HTC VIVE Focus 3 further automatically selects at least one denoising method appropriate to data of at least one frequency subband using the control signals, such as least mean squares adaptive filtering, and/or other forms of noise suppression, and processes the acoustic signals using the selected denoising method to generate denoised acoustic signals.

105. The Accused Products further comprise a system wherein the denoising method includes generating a noise waveform estimate associated with noise of the acoustic signals and subtracting the noise waveform estimate from the acoustic signal when the acoustic signal includes speech and noise. For example, upon information and belief, the HTC VIVE Focus 3 suppresses noise in received signals by generating a waveform associated with noise (*e.g.*, noise detected by a microphone facing away from a user's mouth) and subtracts the noise waveform from the acoustic signal when the signal includes both speech and noise.

106. For example, the Accused Products further comprise a system wherein the voice detection subsystem is configured to receive the voice activity signals using a sensor independent from the microphone array and to output the control signals generated from the voice activity signals to the denoising system, the denoising system configured to use the control signals to denoise the acoustic signals from the microphone array. For example, the HTC VIVE Focus 3 comprises a speech detecting accelerometer independent of a microphone array, configured to supply control signals triggering the denoising subsystem when speech is occurring.

107. HTC has and continues to indirectly infringe one or more claims of the '543 Patent by knowingly and intentionally inducing others, including HTC's customers and end-users of the

Accused Products, to directly infringe, either literally or under the doctrine of equivalents, by making, using, selling, offering to sell, selling, and/or importing into the United States products that include infringing technology, such as the HTC VIVE Focus 3.

108. HTC, with knowledge that these products, or the use thereof, infringe the '543 Patent since at least 2017 but by no later than the date of this Complaint, knowingly and intentionally induced, and continues to knowingly and intentionally induce, direct infringement of the '543 Patent by providing these products to customers and ultimately to end-users for use in an infringing manner in the United States including, but not limited to, products that include infringing technology, such as the HTC VIVE Focus 3. For example, HTC's instruction manuals, websites, promotional materials, advertisements, and other information demonstrate to others, including customers, prospective customers, and distributors, how to use the Accused Products in an infringing manner. Upon information and belief, HTC is aware that the normal and customary use of the Accused Products by customers, distributors, and others would infringe the '543 Patent.

109. HTC has induced infringement by others, including end-users, with the intent to cause infringing acts by others or, in the alternative, with the belief that there was a high probability that others, including end-users, infringe the '543 Patent, but while remaining willfully blind to the infringement.

110. HTC has willfully infringed, and continues to willfully infringe, the '543 Patent by intentionally and deliberately carrying out acts of direct and indirect infringement while knowing or taking deliberate steps to avoid learning that those acts infringe. For example, upon information and belief, HTC has known of Jawbone's patents, including the '543 Patent, at least since they were marketed to HTC following Jawbone, Inc.'s liquidation.

111. Jawbone has suffered damages as a result of HTC's direct and indirect infringement and willful infringement of the '543 Patent in an amount to be proved at trial.

112. Jawbone has suffered, and will continue to suffer, irreparable harm as a result of HTC's infringement of the '543 Patent for which there is no adequate remedy at law, unless HTC's infringement is enjoined by this Court. Accordingly, Jawbone seeks a preliminary and permanent injunction enjoining HTC from making, using, offering to sell, selling, and/or importing the Accused Products, including at least all versions and variants of HTC virtual reality headsets (*e.g.*, VIVE XR Elite, VIVE Flow, VIVE Pro, VIVE Pro2, VIVE Pro Eye, VIVE Cosmos, VIVE Focus 3, VIVE Focus Plus, etc.), HTC home devices (*e.g.*, HTC 5G Hub, etc.), and HTC smartphones (*e.g.*, Exodus 1, Exodus 1 Binance, Exodus 1s, HTC U12+, HTC U11, HTC U11 life, HTC U Ultra, HTC U19e, HTC U20 5G, HTC Desire 20 Pro, HTC Desire 20+, HTC Desire 21 Pro 5G, etc.).

COUNT VI
(Infringement of the '691 Patent)

113. Paragraphs 1 through 31 are incorporated by reference as if fully set forth herein.

114. Jawbone has not licensed or otherwise authorized HTC to make, use, sell, offer to sell, and/or import any products that embody the inventions of the '691 Patent.

115. HTC has and continues to directly infringe the '691 Patent, either literally or under the doctrine of equivalents, without authority and in violation of 35 U.S.C. § 271, by making, using, selling, offering to sell, and/or importing into the United States products that satisfy each and every limitation of one or more claims of the '691 Patent. Upon information and belief, these products include at least the Accused Products, such as those which comprise physical and virtual microphone arrays. The Accused Products include at least all versions and variants of HTC virtual reality headsets (*e.g.*, VIVE XR Elite, VIVE Flow, VIVE Pro, VIVE Pro2, VIVE Pro Eye, VIVE

Cosmos, VIVE Focus 3, VIVE Focus Plus, etc.), HTC home devices (*e.g.*, HTC 5G Hub, etc.), and HTC smartphones (*e.g.*, Exodus 1, Exodus 1 Binance, Exodus 1s, HTC U12+, HTC U11, HTC U11 life, HTC U Ultra, HTC U19e, HTC U20 5G, HTC Desire 20 Pro, HTC Desire 20+, HTC Desire 21 Pro 5G, etc.).

116. For example, HTC has and continues to directly infringe at least claim 23 of the '691 Patent by making, using, selling, offering to sell, selling, and/or importing into the United States products comprising a microphone array comprising: a first virtual microphone formed from a first combination of a first microphone signal and a second microphone signal, wherein the first microphone signal is generated by a first omnidirectional microphone and the second microphone signal is generated by a second omnidirectional microphone; and a second virtual microphone formed from a second combination of the first microphone signal and the second microphone signal, wherein the second combination is different from the first combination; wherein the first virtual microphone has a first linear response to speech that is substantially similar across a plurality of frequencies for a speech source within a predetermined angle relative to an axis of the microphone array and devoid of a null, and a first linear response to noise that is devoid of a null, wherein the second virtual microphone has a second linear response to speech that has a single null oriented in a direction toward a source of the speech and a second linear response to noise that is devoid of a null, wherein the second linear response to noise is substantially similar to the first linear response to noise and the second linear response to speech is substantially dissimilar to the first linear response to speech, wherein the speech is human speech.

117. Each Accused Product comprises a first virtual microphone formed from a first combination of a first microphone signal and a second microphone signal, wherein the first microphone signal is generated by a first omnidirectional microphone and the second microphone

signal is generated by a second omnidirectional microphone. For example, upon information and belief, the HTC VIVE Focus 3 comprises at least two physical omnidirectional microphones, and a first beamformed microphone comprising signals generated by both microphones.

118. Each Accused Product comprises a second virtual microphone formed from a second combination of the first microphone signal and the second microphone signal, wherein the second combination is different from the first combination. For example, upon information and belief, the HTC VIVE Focus 3 comprises a second beamformed microphone comprising signals generated by the first and second physical microphones.

119. Each Accused Product comprises a system wherein the first virtual microphone has a first linear response to speech that is substantially similar across a plurality of frequencies for a speech source within a predetermined angle relative to an axis of the microphone array and devoid of a null, and a first linear response to noise that is devoid of a null. For example, upon information and belief, the first beamformed microphone of the HTC VIVE Focus 3 has a linear response to speech across a predetermined angle relative to an axis of the array pointed towards a user's mouth, and a first linear response to noise in another direction without a null.

120. Each Accused Product comprises a system wherein the second virtual microphone has a second linear response to speech that has a single null oriented in a direction toward a source of the speech and a second linear response to noise that is devoid of a null. For example, upon information and belief, the second beamformed microphone of the HTC VIVE Focus 3 has a linear response to speech that has a single null oriented in a direction towards a source of the speech (*e.g.*, the user's mouth), and a second linear response to noise that is devoid of a null.

121. Each Accused Product comprises a system wherein the second linear response to noise is substantially similar to the first linear response to noise and the second linear response to

speech is substantially dissimilar to the first linear response to speech. For example, upon information and belief, the second linear response to speech of the first beamformed microphone is similar to the first linear response to noise of the first beamformed microphone, and the second linear response to speech of the second beamformed microphone is substantially dissimilar to the first linear response to speech of the first beamformed microphone.

122. Each Accused Product comprises a system wherein the speech is human speech. For example, the speech activity detected by the HTC VIVE Focus 3 is the voice of a user.

123. HTC has and continues to indirectly infringe one or more claims of the '691 Patent by knowingly and intentionally inducing others, including HTC's customers and end-users of the Accused Products, to directly infringe, either literally or under the doctrine of equivalents, by making, using, selling, offering to sell, selling, and/or importing into the United States products that include infringing technology, such as the HTC VIVE Focus 3.

124. HTC, with knowledge that these products, or the use thereof, infringe the '691 Patent since at least 2017 but by no later than the date of this Complaint, knowingly and intentionally induced, and continues to knowingly and intentionally induce, direct infringement of the '691 Patent by providing these products to customers and ultimately to end-users for use in an infringing manner in the United States including, but not limited to, products that include infringing technology, such as the HTC VIVE Focus 3. For example, HTC's instruction manuals, websites, promotional materials, advertisements, and other information demonstrate to others, including customers, prospective customers, and distributors, how to use the Accused Products in an infringing manner. Upon information and belief, HTC is aware that the normal and customary use of the Accused Products by customers, distributors, and others would infringe the '691 Patent.

125. HTC has induced infringement by others, including end-users, with the intent to cause infringing acts by others or, in the alternative, with the belief that there was a high probability that others, including end-users, infringe the '691 Patent, but while remaining willfully blind to the infringement.

126. HTC has willfully infringed, and continues to willfully infringe, the '691 Patent by intentionally and deliberately carrying out acts of direct and indirect infringement, while knowing or taking deliberate steps to avoid learning that those acts infringe. For example, upon information and belief, HTC has known of Jawbone's patents, including the '691 Patent, at least since they were marketed to HTC following Jawbone, Inc.'s liquidation.

127. Jawbone has suffered damages as a result of HTC's direct and indirect infringement and willful infringement of the '691 Patent in an amount to be proved at trial.

128. Jawbone has suffered, and will continue to suffer, irreparable harm as a result of HTC's infringement of the '691 Patent, for which there is no adequate remedy at law, unless HTC's infringement is enjoined by this Court. Accordingly, Jawbone seeks a preliminary and permanent injunction enjoining HTC from making, using, selling, offering to sell, selling, and/or importing the Accused Products, including at least all versions and variants of HTC virtual reality headsets (*e.g.*, VIVE XR Elite, VIVE Flow, VIVE Pro, VIVE Pro2, VIVE Pro Eye, VIVE Cosmos, VIVE Focus 3, VIVE Focus Plus, etc.), HTC home devices (*e.g.*, HTC 5G Hub, etc.), and HTC smartphones (*e.g.*, Exodus 1, Exodus 1 Binance, Exodus 1s, HTC U12+, HTC U11, HTC U11 life, HTC U Ultra, HTC U19e, HTC U20 5G, HTC Desire 20 Pro, HTC Desire 20+, HTC Desire 21 Pro 5G, etc.).

COUNT VII
(Infringement of the '213 Patent)

129. Paragraphs 1 through 31 are incorporated by reference as if fully set forth herein.

130. Jawbone has not licensed or otherwise authorized HTC to make, use, sell, offer to sell, and/or import any products that embody the inventions of the '213 Patent.

131. HTC has and continues to directly infringe the '213 Patent, either literally or under the doctrine of equivalents, without authority and in violation of 35 U.S.C. § 271, by making, using, selling, offering to sell, selling, and/or importing into the United States products that satisfy each and every limitation of one or more claims of the '213 Patent. Upon information and belief, these products include at least the Accused Products, such as those which comprise an acoustic voice activity detector that includes and utilizes physical and virtual microphone arrays. The Accused Products include, but are not limited to, all versions and variants of HTC virtual reality headsets (*e.g.*, VIVE XR Elite, VIVE Flow, VIVE Pro, VIVE Pro2, VIVE Pro Eye, VIVE Cosmos, VIVE Focus 3, VIVE Focus Plus, etc.), HTC home devices (*e.g.*, HTC 5G Hub, etc.), and HTC smartphones (*e.g.*, Exodus 1, Exodus 1 Binance, Exodus 1s, HTC U12+, HTC U11, HTC U11 life, HTC U Ultra, HTC U19e, HTC U20 5G, HTC Desire 20 Pro, HTC Desire 20+, HTC Desire 21 Pro 5G, etc.).

132. For example, HTC has and continues to directly infringe at least claim 1 of the '213 Patent by making, using, selling, offering to sell, selling, and/or importing into the United States products that include an acoustic voice activity detection system comprising: a first virtual microphone comprising a first combination of a first signal and a second signal, wherein the first signal is received from a first physical microphone and the second signal is received from a second physical microphone; a filter, wherein the filter is formed by generating a first quantity by applying a calibration to at least one of the first signal and the second signal, generating a second quantity

by applying a delay to the first signal, and forming the filter as a ratio of the first quantity to the second quantity; and a second virtual microphone formed by applying the filter to the first signal to generate a first intermediate signal and summing the first intermediate signal and the second signal, wherein acoustic voice activity of a speaker is determined to be present when an energy ratio of energies of the first virtual microphone and the second virtual microphone is greater than a threshold value.

133. Each Accused Product comprises a system comprising a first virtual microphone comprising a first combination of a first signal and a second signal, wherein the first signal is received from a first physical microphone and the second signal is received from a second physical microphone. For example, on information and belief, the HTC VIVE Focus 3 forms a first virtual microphone from the outputs of a first and a second physical microphone. For example, upon information and belief, the HTC VIVE Focus 3 comprises at least two physical microphones which supply inputs for beamformed microphones.

134. Each Accused Product comprises a system comprising a filter, wherein the filter is formed by generating a first quantity by applying a calibration to at least one of the first signal and the second signal, generating a second quantity by applying a delay to the first signal, and forming the filter as a ratio of the first quantity to the second quantity. For example, upon information and belief, the Accused Products form a calibration filter, such as a time and/or frequency domain filter, that describes a relationship for speech between at least a first and second physical microphone by applying a delay to the first signal. For example, upon information and belief, the HTC VIVE Focus 3 uses autoregressive filtering to constrain complex fast fourier transform layers to calibration filters. For example, on information and belief, the HTC VIVE Focus 3 further uses adaptive spatial filtering.

135. Each Accused Product comprises a system comprising a second virtual microphone formed by applying the filter to the first signal to generate a first intermediate signal and summing the first intermediate signal and the second signal. For example, upon information and belief, the HTC VIVE Focus 3 forms a second beamformed microphone by applying an adaptive filter to the output of at least a first microphone and summing the filtered output of the first microphone with the output of a second microphone. For example, upon information and belief, the HTC VIVE Focus 3 uses a form of filter-and-sum beamforming with at least an adaptive filter and a calibration filter.

136. Each Accused Product comprises a system wherein acoustic voice activity of a speaker is determined to be present when an energy ratio of energies of the first virtual microphone and the second virtual microphone is greater than a threshold value. For example, on information and belief, the HTC VIVE Focus 3 determines that voicing activity of a speaker is present when a ratio of energies between beamformed microphones is greater than a threshold value associated with a wake word.

137. HTC has and continues to indirectly infringe one or more claims of the '213 Patent by knowingly and intentionally inducing others, including HTC's customers and end-users of the Accused Products, to directly infringe, either literally or under the doctrine of equivalents, by making, using, selling, offering to sell, selling, and/or importing into the United States products that include infringing technology, such as the HTC VIVE Focus 3.

138. HTC, with knowledge that these products, or the use thereof, infringe the '213 Patent since at least 2017 but by no later than the date of this Complaint, knowingly and intentionally induced, and continues to knowingly and intentionally induce, direct infringement of the '213 Patent by providing these products to customers and ultimately to end-users for use in an

infringing manner in the United States including, but not limited to, products that include infringing technology, such as the HTC VIVE Focus 3. For example, HTC's instruction manuals, websites, promotional materials, advertisements, and other information demonstrate to others, including customers, prospective customers, and distributors, how to use the Accused Products in an infringing manner. Upon information and belief, HTC is aware that the normal and customary use of the Accused Products by customers, distributors, and others would infringe the Patent-in-Suit.

139. HTC has induced infringement by others, including end-users, with the intent to cause infringing acts by others or, in the alternative, with the belief that there was a high probability that others, including end-users, infringe the '213 Patent, but while remaining willfully blind to the infringement.

140. HTC has willfully infringed, and continues to willfully infringe, the '213 Patent by intentionally and deliberately carrying out acts of direct and indirect infringement, while knowing, or taking deliberate steps to avoid learning, that those acts infringe. For example, upon information and belief, HTC has known of Jawbone's patents, including the '213 Patent, at least since they were marketed to HTC following Jawbone, Inc.'s liquidation.

141. Jawbone has suffered damages as a result of HTC's direct and indirect infringement and willful infringement of the '213 Patent in an amount to be proved at trial.

142. Jawbone has suffered, and will continue to suffer, irreparable harm as a result of HTC's infringement of the '213 Patent for which there is no adequate remedy at law, unless HTC's infringement is enjoined by this Court. Accordingly, Jawbone seeks a preliminary and permanent injunction enjoining HTC from making, using, selling, offering to sell, selling, and/or importing the Accused Products, including at least all versions and variants of HTC virtual reality headsets

(*e.g.*, VIVE XR Elite, VIVE Flow, VIVE Pro, VIVE Pro2, VIVE Pro Eye, VIVE Cosmos, VIVE Focus 3, VIVE Focus Plus, etc.), HTC home devices (*e.g.*, HTC 5G Hub, etc.), and HTC smartphones (*e.g.*, Exodus 1, Exodus 1 Binance, Exodus 1s, HTC U12+, HTC U11, HTC U11 life, HTC U Ultra, HTC U19e, HTC U20 5G, HTC Desire 20 Pro, HTC Desire 20+, HTC Desire 21 Pro 5G, etc.).

COUNT VIII
(Infringement of the '611 Patent)

143. Paragraphs 1 through 31 are incorporated by reference as if fully set forth herein.

144. Jawbone has not licensed or otherwise authorized HTC to make, use, sell, offer to sell, and/or import any products that embody the inventions of the '611 Patent.

145. HTC has and continues to directly infringe the '611 Patent, either literally or under the doctrine of equivalents, without authority and in violation of 35 U.S.C. § 271, by making, using, selling, offering to sell, and/or importing into the United States products that satisfy each and every limitation of one or more claims of the '611 Patent. Upon information and belief, these products include at least the Accused Products, such as those which comprise an acoustic voice activity detector that includes and utilizes physical and virtual microphone arrays. The Accused Products include, but are not limited to, all versions and variants of HTC virtual reality headsets (*e.g.*, VIVE XR Elite, VIVE Flow, VIVE Pro, VIVE Pro2, VIVE Pro Eye, VIVE Cosmos, VIVE Focus 3, VIVE Focus Plus, etc.), HTC home devices (*e.g.*, HTC 5G Hub, etc.), and HTC smartphones (*e.g.*, Exodus 1, Exodus 1 Binance, Exodus 1s, HTC U12+, HTC U11, HTC U11 life, HTC U Ultra, HTC U19e, HTC U20 5G, HTC Desire 20 Pro, HTC Desire 20+, HTC Desire 21 Pro 5G, etc.).

146. For example, HTC has and continues to directly infringe at least claim 1 of the '611 Patent by making, using, selling, offering to sell, and/or importing into the United States products

that perform a method comprising: forming a first virtual microphone by combining a first signal of a first physical microphone and a second signal of a second physical microphone; forming a filter that describes a relationship for speech between the first physical microphone and the second physical microphone; forming a second virtual microphone by applying the filter to the first signal to generate a first intermediate signal, and summing the first intermediate signal and the second signal; generating an energy ratio of energies of the first virtual microphone and the second virtual microphone; and detecting acoustic voice activity of a speaker when the energy ratio is greater than a threshold value.

147. Each Accused Product performs a method comprising forming a first virtual microphone by combining a first signal of a first physical microphone and a second signal of a second physical microphone. For example, on information and belief, the HTC VIVE Focus 3 forms a first virtual microphone from the outputs of a first and a second physical microphones. For example, upon information and belief, the HTC VIVE Focus 3 comprises at least two physical microphones which supply inputs for beamformed microphones.

Top view

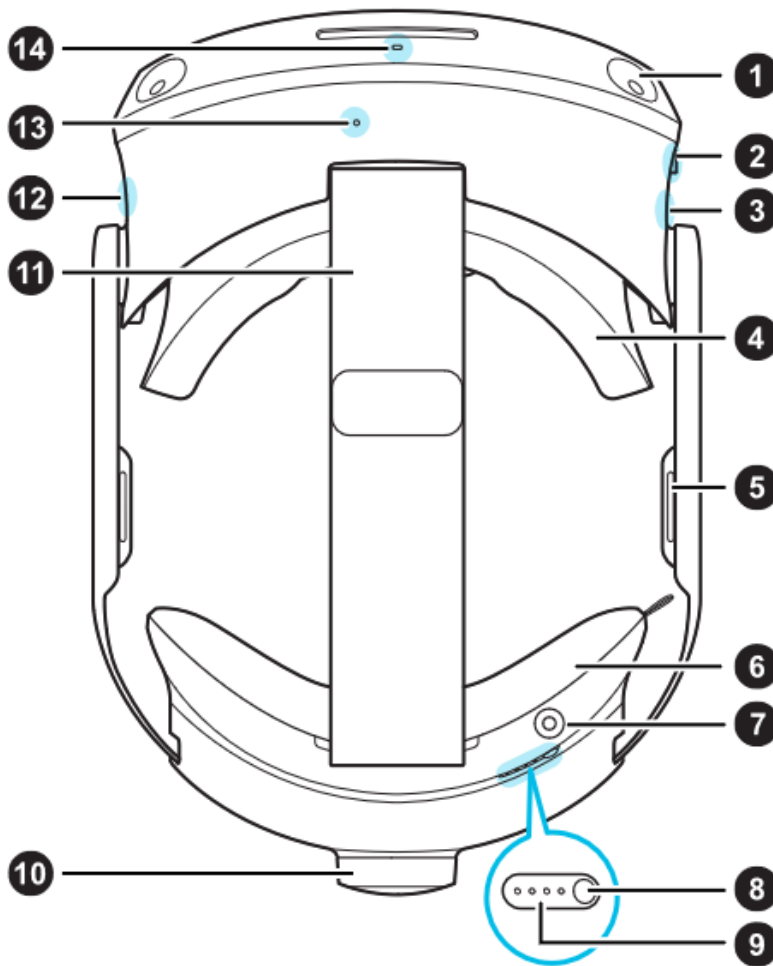

1	Headset camera (4x)
2	3.5mm audio jack
3	USB Type-C® port
4	Face cushion and frame
5	Built-in speaker
6	Back pad
7	Charging port
8	Power button
9	Battery LEDs
10	Adjustment dial
11	Headset strap
12	Headset button
13	Microphone
14	Headset LED

Bottom view

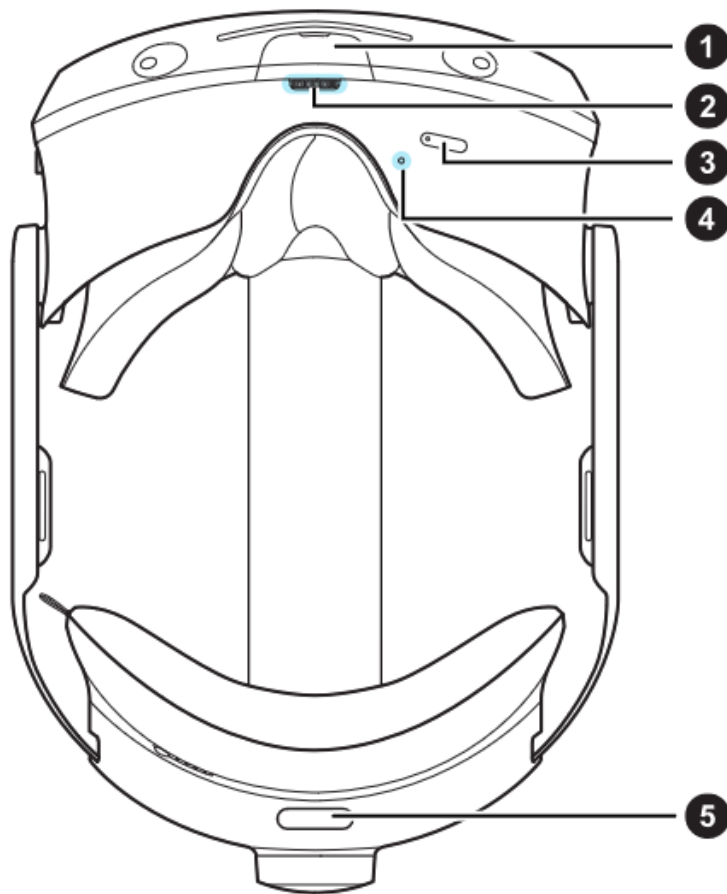

1	USB Type-C port (remove cover)
2	IPD dial
3	Volume buttons
4	Microphone
5	Quick adjustment button

10

148. Each Accused Product performs a method comprising forming a filter that describes a relationship for speech between the first physical microphone and the second physical microphone. For example, upon information and belief, the Accused Products form a calibration filter, such as a time and/or frequency domain filter, that describes a relationship for speech between at least a first and second physical microphone. For example, upon information and belief, the HTC VIVE Focus 3 uses autoregressive filtering to constrain complex fast fourier

¹⁰ https://dl4.htc.com/Web_materials/Manual/Vive_Focus3/VIVE_FOCUS3_UG.pdf

transform layers to calibration filters. For example, on information and belief, the HTC VIVE Focus 3 further uses adaptive spatial filtering.

149. Each Accused Product performs a method comprising forming a second virtual microphone by applying the filter to the first signal to generate a first intermediate signal and summing the first intermediate signal and the second signal. For example, upon information and belief, the HTC VIVE Focus 3 forms a second beamformed microphone by applying an adaptive filter to the output of at least a first microphone and summing the filtered output of the first microphone with the output of a second microphone. For example, upon information and belief, the HTC VIVE Focus 3 uses a form of filter-and-sum beamforming with at least an adaptive filter and a calibration filter.

150. Each Accused Product performs a method comprising generating an energy ratio of energies of the first virtual microphone and the second virtual microphone; and detecting acoustic voice activity of a speaker when the energy ratio is greater than a threshold value. For example, on information and belief, the HTC VIVE Focus 3 determines that voicing activity of a speaker is present when a ratio of energies between beamformed microphones is greater than a threshold value associated with a wake word.

151. HTC has and continues to indirectly infringe one or more claims of the '611 Patent by knowingly and intentionally inducing others, including HTC's customers and end-users of the Accused Products, to directly infringe, either literally or under the doctrine of equivalents, by making, using, selling, offering to sell, and/or importing into the United States products that include infringing technology, such as the HTC VIVE Focus 3.

152. HTC, with knowledge that these products, or the use thereof, infringe the '611 Patent since at least 2017 but by no later than the date of this Complaint, knowingly and

intentionally induced, and continues to knowingly and intentionally induce, direct infringement of the '611 Patent by providing these products to customers and ultimately to end-users for use in an infringing manner in the United States including, but not limited to, products that include infringing technology, such as the HTC VIVE Focus 3. For example, HTC's instruction manuals, websites, promotional materials, advertisements, and other information demonstrate to others, including customers, prospective customers, and distributors, how to use the Accused Products in an infringing manner. Upon information and belief, HTC is aware that the normal and customary use of the Accused Products by customers, distributors, and others would infringe the Patents-in-Suit.

153. HTC has induced infringement by others, including end-users, with the intent to cause infringing acts by others or, in the alternative, with the belief that there was a high probability that others, including end-users, infringe the '611 Patent, but while remaining willfully blind to the infringement.

154. HTC has willfully infringed, and continues to willfully infringe, the '611 Patent by intentionally and deliberately carrying out acts of direct and indirect infringement, while knowing, or taking deliberate steps to avoid learning, that those acts infringe. For example, upon information and belief, HTC has known of Jawbone's patents, including the '611 Patent, at least since they were marketed to HTC following Jawbone, Inc.'s liquidation.

155. Jawbone has suffered damages as a result of HTC's direct and indirect infringement and willful infringement of the '611 Patent in an amount to be proved at trial.

156. Jawbone has suffered, and will continue to suffer, irreparable harm as a result of HTC's infringement of the '611 Patent for which there is no adequate remedy at law, unless HTC's infringement is enjoined by this Court. Accordingly, Jawbone seeks a preliminary and permanent

injunction enjoining HTC from making, using, selling, offering to sell, selling, and/or importing the Accused Products, including at least all versions and variants of HTC virtual reality headsets (*e.g.*, VIVE XR Elite, VIVE Flow, VIVE Pro, VIVE Pro2, VIVE Pro Eye, VIVE Cosmos, VIVE Focus 3, VIVE Focus Plus, etc.), HTC home devices (*e.g.*, HTC 5G Hub, etc.), and HTC smartphones (*e.g.*, Exodus 1, Exodus 1 Binance, Exodus 1s, HTC U12+, HTC U11, HTC U11 life, HTC U Ultra, HTC U19e, HTC U20 5G, HTC Desire 20 Pro, HTC Desire 20+, HTC Desire 21 Pro 5G, etc.).

DEMAND FOR JURY TRIAL

Plaintiff hereby demands a jury for all issues so triable.

PRAYER FOR RELIEF

WHEREFORE, Jawbone prays for relief against HTC as follows:

- a. Entry of judgment declaring that HTC has directly and/or indirectly infringed one or more claims of each of the Patents-in-Suit;
- b. Entry of judgment declaring that HTC's infringement of the Patents-in-Suit is willful;
- c. Entry of a preliminary injunction enjoining HTC from making, using, selling, offering to sell, and/or importing the Accused Products;
- d. Entry of a permanent injunction enjoining HTC from making, using, selling, offering to sell, and/or importing the Accused Products;
- e. An order awarding damages sufficient to compensate Jawbone for HTC's infringement of the Patents-in-Suit, but in no event less than a reasonable royalty, including supplemental damages post-verdict, together with pre-judgment and post-judgment interest and costs;

- f. Entry of judgment declaring that this case is exceptional and awarding Jawbone its costs and reasonable attorneys' fees under 35 U.S.C. § 285;
- g. An accounting for acts of infringement;
- h. Such other equitable relief which may be requested and to which the Plaintiff is entitled; and
- i. Such other and further relief as the Court deems just and proper.

Dated: February 28, 2023

Respectfully submitted,

/s/ Alfred R. Fabricant

Alfred R. Fabricant
NY Bar No. 2219392
Email: ffabricant@fabricantllp.com
Peter Lambrianakos
NY Bar No. 2894392
Email: plambrianakos@fabricantllp.com
Vincent J. Rubino, III
NY Bar No. 4557435
Email: vrubino@fabricantllp.com
FABRICANT LLP
411 Theodore Fremd Avenue,
Suite 206 South
Rye, New York 10580
Telephone: (212) 257-5797
Facsimile: (212) 257-5796

Samuel F. Baxter
Texas State Bar No. 01938000
Email: sbaxter@mckoolsmith.com
Jennifer L. Truelove
Texas State Bar No. 24012906
Email: jtruelove@mckoolsmith.com
MCKOOL SMITH, P.C.
104 East Houston Street, Suite 300
Marshall, Texas 75670
Telephone: (903) 923-9000
Facsimile: (903) 923-9099

**ATTORNEYS FOR PLAINTIFF
JAWBONE INNOVATIONS, LLC**