

**IN THE UNITED STATES DISTRICT COURT
FOR THE EASTERN DISTRICT OF TEXAS
MARSHALL DIVISION**

WILLOW INNOVATIONS, INC.,

Plaintiff,

v.

CHIARO TECHNOLOGY, LTD.,

Defendant.

Case No. 2:23-cv-00229

Jury Trial Demanded

COMPLAINT FOR PATENT INFRINGEMENT

Plaintiff Willow Innovations, Inc. (“Willow” or “Plaintiff”) brings this case for willful patent infringement against Defendant Chiaro Technology, Ltd. d/b/a Elvie (“Elvie” or “Defendant”). Elvie infringes seven patents that cover Willow’s innovative and ground-breaking wearable breast milk pump. Willow’s product revolutionized this fundamentally important function of human child rearing, and improved the lives of mothers and babies throughout the U.S. Elvie’s launch of its infringing product amounts to willful patent infringement, and Willow has been damaged to the tune of tens of millions of dollars as a result. Willow seeks redress from this Court and a jury for Elvie’s deliberate and wrongful acts.

THE PARTIES

1. Plaintiff Willow Innovations, Incorporated is a corporation organized and existing under the laws of the State of Delaware, having a principal place of business at 1975 El Camino Real, Suite 306, Mountain View, CA 94040. On October 21, 2020, Willow changed its name from “Exploramed NC7, Inc.” to “Willow Innovations, Inc.”

2. Defendant Chiaro Technology, Limited is a corporation organized and existing under the laws of the United Kingdom, with its principal place of business at 63-66 Hatton Garden, EC1N 8LE, London, United Kingdom. On the information and belief, Elvie is the trading name of Chiaro Technology Limited and conducts business, either directly or through its agents, on an ongoing basis in this judicial district and elsewhere in the United States.

BACKGROUND

3. Traditional breast milk pumps were decades overdue for innovation. Enter the Willow Pump. Founded in 2014, Willow revolutionized the way women pump with the world’s first spillproof, in-bra wearable breast pump. Selected as one of TIME Magazine’s 25 Best Inventions, the Willow pump was the first to get rid of the heavy motors, tubes, and electrical cords—and put moms in control. Traditional pumps required nursing moms to sacrifice hours of their day connected to an electrical outlet or to a heavy, conspicuous appliance. Pumping in public required either exposing a breast in public, or relying on a public bathroom or similarly inconvenient location.¹ Willow was the first to make it possible to pump anywhere, giving moms

¹ The inconvenience of traditional pumps is a factor for many women who abandon breast-feeding. The benefits of breast-feeding are widely known, and include reduced risk of disease for infants and various health benefits for the mother. *See* <https://www.cdc.gov/breastfeeding/about-breastfeeding/why-it-matters.html>. The American Academy of Pediatrics (AAP) updated their policy statement in July 2022 to support breastfeeding for at least the first two years. *See* <https://doi.org/10.1542/peds.2022-057988>.

back their privacy, dignity, and freedom of movement. Since then, Willow has grown into a market leader, providing moms with industry-leading suction technology. Willow has gradually grown its array of product offerings, with a primary focus on the U.S.—the world’s largest market for breast pumps.

4. Also in 2014, Willow filed for its first United States patent application. It now holds more than 35 issued U.S. patents covering the functionality and designs of its products, with additional applications currently pending before the United States Patent Office (“USPTO”). In addition, Willow holds dozens of international patents in jurisdictions such as Australia, Singapore, China, Europe, Japan, Korea, Hong Kong, and the United Kingdom. To protect its hard-earned innovations, Willow provides notice to prospective infringers of its extensive patent portfolio via its website. <https://onewillow.com/about-willow/patents/>. This publication also satisfies the standard for constructive notice under 35 U.S.C. § 287(a) for purposes of virtual patent marking.

5. Today, Willow is a market leader in “femtech”—a shorthand term used to describe technology products and services that support women’s health. The femtech industry is projected to be worth \$50 billion by 2025. Willow’s product offerings include wearable pumps, containers, pumping bras, carrying bags, and other accessories. <https://onewillow.com/#>. Willow offers for sale these products via its website and through select retailers and online marketplaces, such as Target, Best Buy, buybuy Baby, and Amazon.

6. Elvie is based in the United Kingdom and launched its Elvie Pump system in 2018 at the London Fashion Week. <https://techcrunch.com/2018/09/14/kegel-trainer-startup-elvie-is->

However, data indicate that only 1 in 4 infants is exclusively breastfed by the time they reach 6 months old. See https://www.cdc.gov/breastfeeding/data/nis_data/results.html.

[launching-a-smaller-smarter-breast-pump/](#). Later that year, Elvie received clearance from the U.S. Food and Drug Administration to market the Elvie Pump in the U.S. https://www.accessdata.fda.gov/cdrh_docs/pdf18/K181863.pdf. In its pre-market notification report submitted to the FDA, Elvie admitted that its breast pump is substantially equivalent to the Willow Pump. *See id.* (citing product code “HGX” to show the Willow Pump was an FDA-cleared predicate device to the Elvie Pump).

7. Elvie has exploited Willow’s patented technology to secure more than \$150 million in funding from investors. Most recently, in 2021, Elvie secured \$97 million in its Series C funding round. <https://techcrunch.com/2021/09/07/womens-health-tech-brand-elvie-tops-up-series-c-to-97m/>.

8. Elvie has leveraged Willow’s patents to establish itself as a major manufacturer and distributor of consumer breast feeding equipment. Willow brings this suit to protect its constitutional patent rights against Elvie’s past and continued infringement.

JURISDICTION AND VENUE

9. This is a civil action for patent infringement arising under the patent laws of the United States, 35 U.S.C. §§ 100 *et seq.* This Court has jurisdiction over the subject matter of this action pursuant to 28 U.S.C. §§ 1331 and 1338(a).

10. This Court has personal jurisdiction over Elvie at least because it (1) has committed acts of patent infringement and contributed to and induced acts of patent infringement by others in this District; (2) regularly did business or solicited business in this District; (3) engaged in other persistent courses of conduct and derived substantial revenue by its offering of infringing products and services and providing infringing products and services in this District; and (4) purposefully established substantial, systematic, and continuous contacts with this District and should have

reasonably expected to be subject to suit here by its offering of infringing products and services and providing infringing products and services in this District.

11. Elvie has sold their breast pumps and related products within this District via the following means:

- a. Through its own online store at <http://www.elvie.com>, customers—including those in this District and throughout Texas—can purchase Elvie’s suite of products. Upon information and belief, Elvie uses its agents and distribution partners to direct infringing products purchased online to customers in this District. Elvie also uses its website to engage with and support its customers. For example, Elvie provides instructions for using the Elvie Pump through a variety of publicly-available resources, including product manuals, answers to common questions, and how-to videos. https://www.elvie.com/assets/manuals/elvie_pump_manual_en.pdf; <https://www.elvie.com/en-us/support/elvie-pump>.
- b. Elvie has authorized at least nine retailers and distributors to sell its products, as described at <https://www.elvie.com/en-us/partners/b2b-partners>. These partners include major retailers such as Walmart, Amazon, Target, Costco, and Best Buy—all of which maintain stores, warehouse facilities, and/or distribution centers in this District. As detailed below, customers in this District may purchase Elvie products from authorized sellers via (1) the authorized seller’s website; or (2) the authorized seller’s brick-and-mortar store located within the District.²

² Elvie’s distribution partners, such as Costco and Amazon, also maintain facilities in this District. See <https://www.costco.com/warehouse-locations/mckinney-tx-1284.html> (showing Costco warehouse in McKinney, TX); <https://hiring.amazon.com/jobDetail/en-US/Amazon-Delivery-Station-Warehouse-Associate/McKinney/a0R4U00000EP4YeUAL#/jobDetail?jobId=a0R4U00000EP4YeUAL&loc>

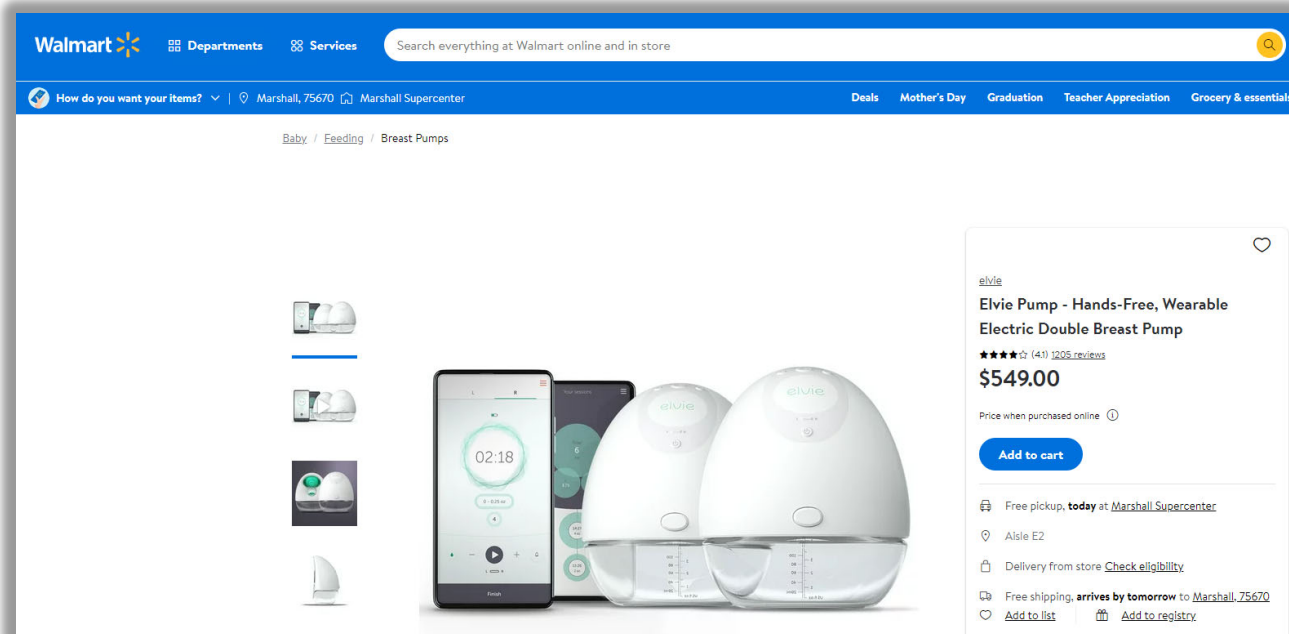

Elvie Pump – Hands-Free, Wearable Electric Double Breast Pump, Walmart (last visited May 15, 2023), <https://www.walmart.com/ip/Elvie-Pump-Hands-Free-Wearable-Electric-Double-Breast-Pump/347662224?fulfillmentIntent=In-store&adsRedirect=true> (showing Elvie Double Electric Breast Pump is available for online purchase and also is in stock at Marshall Supercenter in Marshall, TX).

[ale=en-US&seoIndex=1](#) (advertising job based at Amazon facility, called “DDX2,” in McKinney, TX).

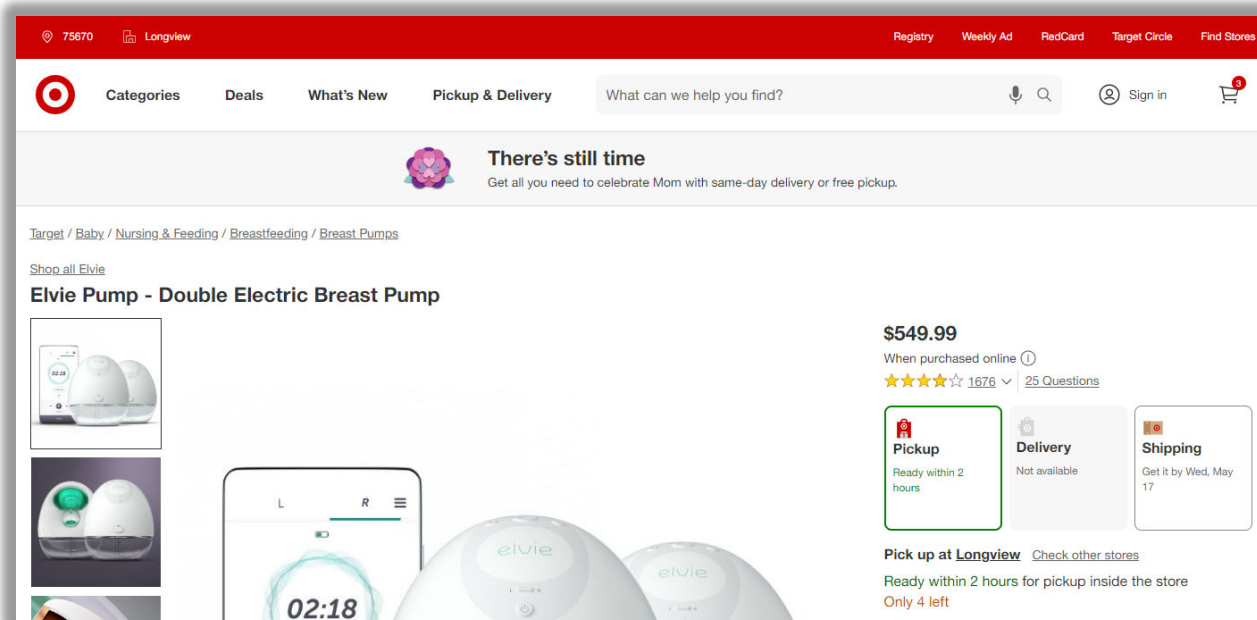

Elvie Pump – Double Electric Breast Pump, TARGET (last visited May 15, 2023), <https://www.target.com/p/elvie-pump-double-electric-breast-pump/-/A-75662623#lnk=sametab> (showing Elvie Double Electric Breast Pump is available for online purchase and also is in stock at Target in Longview, TX).

12. Elvie purposefully avails itself of the benefit of conducting business in Texas by marketing and selling its products to citizens in the state (including in this District). The United States is the largest market in the world for breast pump products, and Texas is the second largest state in the United States by population. Given the size of the market and the significant presence of retailers, distributors, and other business partners in the state, Elvie has specifically targeted Texas as a key market for its products. For example, in August 2022, Elvie’s Chief Commercial Officer, Aoife Zakaras-Nally, provided comments to the Houston Chronicle³ touting the benefits

³ The Houston Chronicle’s parent company, the Hearst Corporation, states that the Chronicle has “825,000 daily readers and 1.4 million readers on Sunday.” <https://www.hearst.com/newspapers/houston-chronicle#:~:text=In%20addition%20to%20the%20Houston,million%20unique%20visitors%20each%20month.>

and commercial success of the Elvie Pump. <https://www.houstonchronicle.com/lifestyle/renew-houston/health/article/Breastfeeding-will-never-be-free-But-it-can-be-17339050.php?cmpid=gsa-chron-result>. Houston is a particularly important market for Elvie, given the size and reach of its medical community. *See id.* (Dr. Stan Spinner, chief medical officer of Texas Children’s Hospital based in Houston, describing the benefits of breastfeeding).

13. In addition, on information and belief, Elvie exercises control over its distributors, retailers, and other partners that conduct Elvie’s business in Texas. For example, Elvie limits its product warranty—ranging in duration from 90 days to two years from the date of purchase—to those products purchased directly from Elvie and its authorized sellers. *See* <https://www.elvie.com/en-us/warranty> (“[T]his limited warranty applies only to original purchasers of Elvie Product(s) that were purchased from Chiaro or a Chiaro authorized seller in the United States, unless otherwise prohibited by law.”). On its website, Elvie provides instructions for anyone interested in becoming an authorized seller of Elvie products. <https://www.elvie.com/en-us/partners/b2b-partners>.

14. Elvie, directly and through subsidiaries or intermediaries (including distributors, retailers, and others), has purposefully and voluntarily placed its infringing products into this District and into the stream of commerce with the intention and expectation that the infringing products will be purchased for use in Texas and in this District. Elvie has imported, offered for sale and sold, and continues to import, offer for sale and sell, infringing products for delivery and use in this District. Thus, Elvie has intentionally targeted Texas, and this District, for its business activities, and has purposefully availed itself of the benefits of conducting business in Texas such that it should reasonably anticipate being subject to its laws and the jurisdiction of its courts.

Further, Willow's infringement allegations arise out of and relate to Elvie's commercial activities in Texas.

15. Venue is proper in this District under at least 28 U.S.C. §§ 1391(b), (c) and/or 1400(b). Venue is proper with respect to Elvie because it is a foreign entity that has committed acts of infringement in this District, as detailed throughout this Complaint. Elvie has committed and continues to commit acts of patent infringement in this District, by, among other things, directly and/or indirectly making, using, selling, offering to sell, or importing products that infringe one or more claims of the Patents-in-Suit.

THE ASSERTED PATENTS

16. This action involves seven asserted patents: U.S. Patent No. 10,398,816 ("the '816 Patent"), U.S. Patent No. 10,434,228 ("the '228 Patent"), U.S. Patent No. 10,625,005 ("the '005 Patent"), U.S. Patent No. 10,722,624 ("the '624 Patent"), U.S. Patent No. 11,185,619 ("the '619 Patent"), U.S. Design Patent No. D832,995 ("the 'D995 Patent"), and U.S. Design Patent No. D977,625 ("the 'D625 Patent") (collectively, the "Asserted Patents").

17. The Asserted Patents recognized multiple problems with then-existing systems and methods for pumping milk. For example, as the '624 Patent explains, "[a]lthough a variety of breast pumps are available, most are awkward and cumbersome, requiring many parts and assemblies and being difficult to transport." Exhibit 1 at 1:30-32. Manual breast pumps can be "onerous" and "painful" to use. *Id.* at 1:33-34. Some of the available powered breast pumps "require an AC power source to plug into during use," while other available battery-powered pumps "draw down the battery power fairly rapidly as the motorized pump continuously operates to maintain suction during the milk extraction process." *Id.* at 1:36-38. Existing pumps had the further disadvantages of being "clearly visible to an observer when the mother is using it" and

“expos[ing] the breast of the mother during use.” *Id.* at 1:38-41. As the ’624 Patent explains, “[t]here is a continuing need for a small, portable...wearable breast pump system” that would not expose the breast of the user, and could be “invisible or nearly unnoticeable when worn.” *Id.* at 1:42-46.

18. To address these deficiencies in the art, the Asserted Patents provide a wearable, inconspicuous, convenient pump. In various embodiments, “the system defines a natural breast profile” which would “fit comfortably and conveniently into a bra of a user and to present a natural look.” Exhibit 1 at 2:5-8. The pumping devices and storage containers of the inventions can be “sized and shaped to be received within a user’s bra.” *Id.* at 2:24-26. “Pumping of milk from a breast can occur without creating a change in a total mass and volume of the breast, pump device and storage container. The storage container can be one or more of flexible, or position around the breast.” *Id.* at 2:26-30.

U.S. Patent No. 10,398,816

19. On September 3, 2019, the USPTO duly and lawfully issued the ’816 Patent, entitled “Breast pump system with flange.” A true and correct copy of the ’816 Patent is attached as Exhibit 2. By assignment, duly recorded with the USPTO, Willow owns all substantial rights to the ’816 Patent, including the right to sue and recover damages for all infringement.⁴

20. The ’816 Patent generally relates to a breast pumping system where milk is expressed from the breast under suction, and the milk is moved by the pumping mechanism to a collection container using pressure and all responsive to a controller. *See id.* at Abstract. The ’816

⁴ Although the Asserted Patents were originally assigned to “Exploramed NC7, Inc.,” that entity has since changed its name to “Willow Innovations, Inc.” Ex. 3. Thus, Plaintiff Willow Innovations, Inc. is the current assignee and title holder of the Asserted Patents and the owner of all rights and interest in the same.

Patent further provides for a portion of the system that contacts the skin, called the flange, designed as a “lower profile component” as compared to the prior art. *Id.* at 20:10-11.

21. The ’816 Patent recognized a problem with then-existing systems and methods for pumping milk. As the ’816 Patent explains, “[a]lthough a variety of breast pumps are available, most are awkward and cumbersome, requiring many parts and assemblies and being difficult to transport.” Exhibit 2 at 1:23-25. Manual breast pumps can be “onerous” and “painful” to use. *Id.* at 1:25-27. Some of the available powered breast pumps “require an AC power source to plug into during use,” while other available battery-powered pumps “draw down the battery power fairly rapidly as the motorized pump continuously operates to maintain suction during the milk extraction process.” *Id.* at 1:27-31. Existing pumps had the further disadvantages of being “clearly visible to an observer when the mother is using it” and “expos[ing] the breast of the mother during use.” *Id.* at 1:31-34. In addition, “[m]any existing breast pump systems can cause considerable discomfort to the user over time. One cause of such discomfort is chafing of the nipple against the nipple flange/housing as the nipple stretches and contracts during the pumping session. There is a continuing need for a breast pump system that is more comfortable to the user, even over repeated pumping sessions.” *Id.* at 1:49-55.

22. The ’816 Patent describes specific improvements to then-existing systems and methods for pumping milk. For example, in various embodiments, “the system defines a natural breast profile” which would “fit comfortably and conveniently into a bra of a user and to present a natural look.” *Id.* at 2:14-18. In addition, the claimed system maintains “at least a latch suction level at all times,” which results in a “more secure and persistent seal to the breast and significantly reduce[d] potential for leaks.” *Id.* at 20:3-6. This has several benefits to the user, including “less friction on the side of the nipple against the flange wall, thereby greatly reducing the risk of

irritation, skin damage, pain, swelling, etc.” *Id.* at 19:64-67. Additionally, because “the nipple travels less, this allows for the skin attachment member/flange to be designed as a lower profile component, as its length can be shorter...” *Id.* at 20:9-11. This benefit in turn limits the “overall amount of protrusion of the system from the breast to less than that in the prior art...” *Id.* at 20:13-15.

23. As an example of the improvements in the '816 Patent over the prior art, Figure 8 provides a flange of an embodiment of the invention, and Figure 9 provides an exemplary prior art flange:

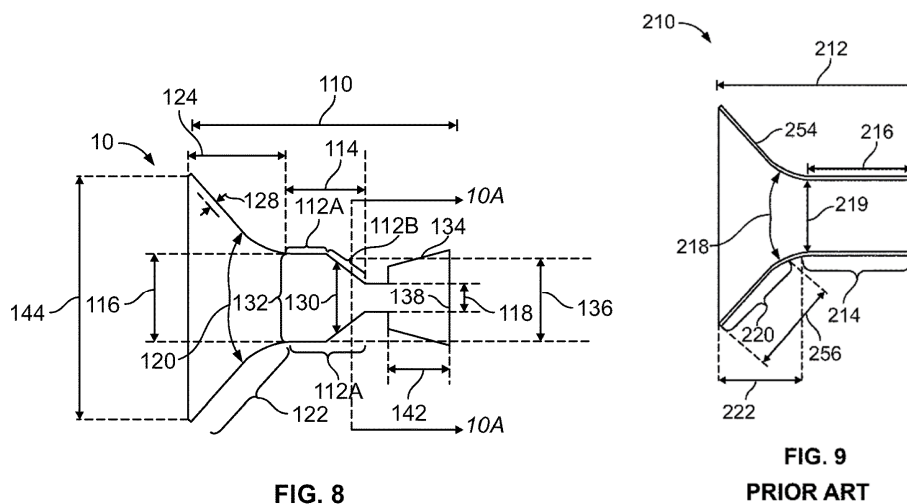

24. The claims of the '816 Patent capture specific technological improvements. For example, Claim 1 of the '816 Patent provides for “a flange attached to the breast pump shell and configured to receive the breast” with a “rigid nipple receiving portion.” *Id.*, Claim 1, 50:56-61. Claim 6 of the '816 Patent adds a limitation to a “control loop [] used to adjust a speed of the compression member to vary or maintain the suction pressure.” *Id.*, Claim 6, 51:12-16.

25. The claimed improvements of the '816 Patent, including the ability to maintain suction and the corresponding characteristics of the claimed flange, were not routine, conventional, or well-known. These improvements were advantageous and inventive over the prior art systems

that were cumbersome, difficult to transport, inefficient and/or inconvenient to power, and difficult to use discreetly. The '816 Patent recognized the unconventional and advantageous nature of the claimed small, portable, self-powered, energy efficient, wearable breast pump system. *Id.* at 1:35-49. As the '816 Patent explains, these improvements were advantageous and inventive over the prior art systems with less comfortable skin contact portions. The '816 Patent recognized the unconventional and advantageous nature of achieving a shorter protrusion of the system from the breast, by providing improved suction and, in turn, the claimed flange. The improved systems and methods of the '816 Patent, recited in the claims, provide technological benefits over the prior art.

U.S. Patent No. 10,434,228

26. On October 8, 2019, the USPTO duly and lawfully issued the '228 Patent, entitled “Breast pump system and methods.” A true and correct copy of the '228 Patent is attached as Exhibit 4. By assignment, duly recorded with the USPTO, Willow owns all substantial rights to the '228 Patent, including the right to sue and recover damages for all infringement.

27. The '228 Patent generally relates to a breast pumping system where milk is expressed from the breast under suction, and the milk is moved by the pumping mechanism to a collection container using pressure. *See id.* at Abstract.

28. The '228 Patent recognized a problem with then-existing systems and methods for pumping milk. As the '228 Patent explains, “[w]hen a user has completed the pumping phase of extracting milk..., it is useful and efficient to purge as much milk that remains...from the tubing [] and into the milk collection container [.]” *Id.* at 41:8-11.

29. The '228 Patent describes specific improvements to then-existing systems and methods for pumping milk. In particular, the '228 Patent provides systems with numerous methods for avoiding loss of milk after extraction from the breast. For example, Figure 38

illustrates events that may be carried out to perform a purge. *Id.* at 14:37-39. Figures 39A and 39B further provide additional arrangements that may be provided to help prevent loss of milk out of the system.

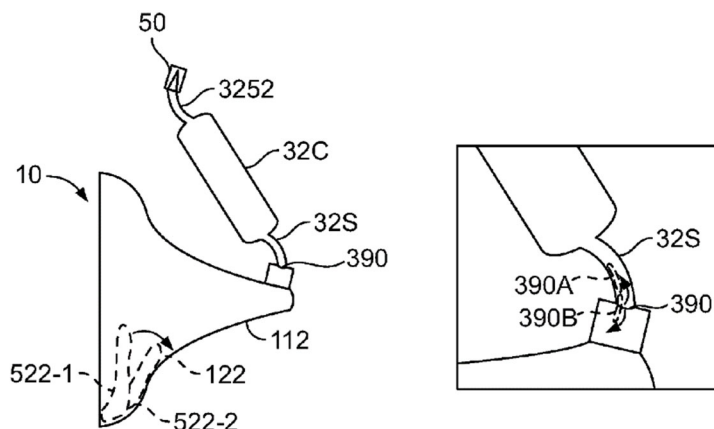

FIG. 39A

FIG. 39B

30. The claims of the '228 Patent capture specific technological improvements. For example, Claim 1 provides an automated method of pumping milk, “wherein the milk is pumped from the breast to the collection container upwardly through the milk flow path relative to a bottom of the breast contacting structure.” *Id.* at Claim 1, 50:44-47.

31. The claimed improvements of the '228 Patent were not routine, conventional, or well-known. As the '228 Patent explains, these improvements were advantageous and inventive over the prior art techniques without the provided methods of avoiding milk loss. The '228 Patent recognized the unconventional and advantageous nature of directing the flow of milk upward. The improved systems and methods of the '228 Patent, recited in the claims, provide technological benefits over the prior art.

U.S. Patent No. 10,625,005

32. On April 21, 2020, the USPTO duly and lawfully issued the '005 Patent, entitled “Breast pump assembly with remote interface.” A true and correct copy of the '005 Patent is

attached as Exhibit 5. By assignment, duly recorded with the USPTO, Willow owns all substantial rights to the '005 Patent, including the right to sue and recover damages for all infringement.

33. The '005 Patent generally relates to a breast pumping system where milk is expressed from the breast under suction, and the milk is moved by the pumping mechanism to a collection container using pressure. *See id.* at Abstract. The '005 Patent provides for a remote user interface system, including user control functionality. *Id.* at Claim 1, 28:33-34.

34. The '005 Patent recognized a problem with then-existing systems and methods for pumping milk. As the '005 Patent explains, “[t]here is a continuing need for a small, portable, self-powered, energy efficient, wearable breast pump that is easy to use, that mimics natural nursing, and is...nearly unnoticeable when worn.” *Id.* at 1:54-58. In particular, it would be desirable to “easily and accurately monitor[] the volume of milk pumped by the system” and to “track milk volume pumped per session.” *Id.* at 1:59-67.

35. The '005 Patent describes specific improvements to then-existing systems and methods for pumping milk. For example, a remote user interface system allows for “at least the session start time, the session end time and total volume of milk extracted from the breast” to be “stored and tracked.” *Id.* at 25:15-17. Live data and historical data can be treated differently, and be downloaded to an external device during or immediately after a session, or downloaded as multiple session data. *Id.* at 25:27-46. The remote user interface “can also include specific user control functionality, and various related easy to understand displays.” *Id.* at 26:15-16. Figures 30 and 31 provide exemplary aspects of a remote user interface system:

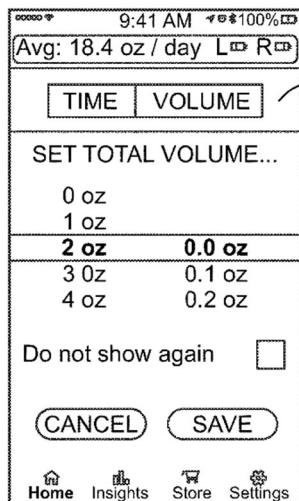

FIG. 30

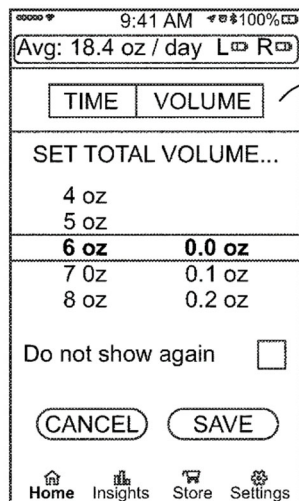

FIG. 31

36. The claims of the '005 Patent capture specific technological improvements. For example, Claim 1 is directed to a breast pump with a wireless transmitter, a “language protocol for two-way communication between the breast pump and an external device,” and a “remote user interface including user control functionality” and “an input for the human to adjust the breast pump with the external device.” *Id.* at Claim 1, 28:25-41.

37. The claimed improvements of the '005 Patent were not routine, conventional, or well-known. As the '005 Patent explains, these improvements were advantageous and inventive over the prior art techniques that did not allow for a remote user interface system. The '005 Patent recognized the unconventional and advantageous nature of a wireless system that empowered nursing mothers to control the operation of the breast pump through an external device. The improved systems and methods of the '005 Patent, recited in the claims, provide technological benefits over the prior art.

U.S. Patent No. 10,722,624

38. On July 28, 2020, the USPTO duly and lawfully issued the '624 Patent, entitled “Breast pump assembly with breast adapter.” A true and correct copy of the '624 Patent is attached

as Exhibit 1. By assignment, duly recorded with the USPTO, Willow owns all substantial rights to the '624 Patent, including the right to sue and recover damages for all infringement.

39. The '624 Patent generally relates to a breast milk pump that uses a pumping mechanism to expulse milk from a breast and to then store the milk in a milk collection container. The entire assembly may include both the pump and the storage container. *See id.* at Abstract.

40. The '624 Patent provides for various embodiments of the breast pumping system. In one example, in order to achieve the desired milk expression, “suction applied to the breast for expression of milk involves a first suction level, and during expulsing, a second suction level is maintained against the breast, the second suction level being lower than the first suction level.” *Id.* at 1:67-2:4.

41. As the '624 Patent explains, “[a]lthough a variety of breast pumps are available, most are awkward and cumbersome, requiring many parts and assemblies and being difficult to transport.” *Id.* at 1:30-32. Manual breast pumps can be “onerous” and “painful” to use. *Id.* at 1:32-34. Some of the available powered breast pumps “require an AC power source to plug into during use,” while other available battery-powered pumps “draw down the battery power fairly rapidly as the motorized pump continuously operates to maintain suction during the milk extraction process.” *Id.* at 1:33-37. Existing pumps had the further disadvantages of being “clearly visible to an observer when the mother is using it” and “expos[ing] the breast of the mother during use.” *Id.* at 1:37-40.

42. The '624 Patent describes specific improvements to then-existing systems and methods for pumping milk. For example, in various embodiments, “the system defines a natural breast profile” which would “fit comfortably and conveniently into a bra of a user and to present a natural look.” *Id.* at 2:5-8. Another approach could include “outputting at least one of

operational and/or sensed parameters, and modifying at least one operational setting based upon” the same. *Id.* at 3:47-49. An operational setting could include “suction level setting, suction waveform definition, extraction phase time, threshold milk volume estimate per extraction phase expulsion, pressure, rest phase time, heating temperatures, heating times, vibration frequency and vibration times.” *Id.* at 3:50-55. The ’624 Patent provides a system or method that “can further perform in real-time, or as a feedback loop.” *Id.* at 3:49-50.

43. The claims of the ’624 Patent capture specific technological improvements. For example, Claim 1 is directed to an “automated system for controlling pumping cycles” including a “sensor which detects when the milk collection container is full” and a controller that “automatically changes application of suction” based on the phase of milk expression from the user. *Id.* at Claim 1, 53:10-54:8.

44. The claimed improvements of the ’624 Patent were not routine, conventional, or well-known. As the ’624 Patent explains, these improvements were advantageous and inventive over the prior art systems that were cumbersome, difficult to transport, inefficient and/or inconvenient to power, and difficult to use discreetly. The ’624 Patent recognized the unconventional and advantageous nature of the claimed small, portable, self-powered, energy efficient, wearable breast pump system. *Id.* at 1:42-46. The claims recited systems with features including control of the pumping cycle. *Id.* at Claim 1, 53:10-54:8. The improved systems and methods of the ’624 Patent, recited in the claims, provide technological benefits over the prior art.

U.S. Patent No. 11,185,619

45. On November 30, 2021, the USPTO duly and lawfully issued the ’619 Patent, entitled “Breast pump system with pressure sensor.” A true and correct copy of the ’619 Patent is

attached as Exhibit 6. By assignment, duly recorded with the USPTO, Willow owns all substantial rights to the '619 Patent, including the right to sue and recover damages for all infringement.

46. The '619 Patent generally relates to a breast pumping system where milk is expressed from the breast under suction, and the milk is moved from the pumping mechanism to a collection container using pressure and all responsive to a controller. *See id.* at Abstract. The system of the '619 Patent further includes a wireless transmitter and a pressure sensor.

47. The '619 Patent recognized a problem with then-existing systems and methods for pumping milk. As the '619 Patent explains, “[a]lthough a variety of breast pumps are available, most are awkward and cumbersome, requiring many parts and assemblies and being difficult to transport.” *Id.* at 1:25-27. Manual breast pumps can be “onerous” and “painful” to use. *Id.* at 1:27-29. Some of the available powered breast pumps “require an AC power source to plug into during use,” while other available battery-powered pumps “draw down the battery power fairly rapidly as the motorized pump continuously operates to maintain suction during the milk extraction process.” *Id.* at 1:30-33. Existing pumps had the further disadvantages of being “clearly visible to an observer when the mother is using it” and “expos[ing] the breast of the mother during use.” *Id.* at 1:33-36. The '619 Patent explained the desirability of “a breast pump system that easily and accurately monitors the volume of milk pumped by the system,” and that it “would also be desirable to track milk volume pumped by the system.” *Id.* at 1:43-49.

48. The '619 Patent describes specific improvements to then-existing systems and methods for pumping milk. For example, the system of the '619 Patent provides for a sensor “used to provide feedback to the controller” to control the pumping cycles. *Id.* at 29:42-48. With a sensor present, “it is possible to derive/calculate approximately the volume of milk produced during a pumping session as well as understand the flow-rate at any particular time in a pumping

session.” *Id.* at 30:8-14. The ’619 Patent further provides for wireless connection between the controller of the pumping system and an external computer, such as a smartphone or laptop. *Id.* at 35:66-36:5. Through this connection, the system of the ’619 Patent can compile information related to milk extraction and collection. *Id.* at 37:25-32; 38:21-39.

49. The claims of the ’619 Patent capture specific technological improvements. For example, Claim 1 is directed to a system that includes a vacuum pumping mechanism, a wireless transmitter, and a non-contact pressure sensor that measures vacuum levels within the automated system. *Id.* at Claim 1, 50:44-61.

50. The claimed improvements of the ’619 Patent were not routine, conventional, or well-known. As the ’619 Patent explains, these improvements were advantageous and inventive over the prior art techniques that did not meet the needs of nursing mothers. The ’619 Patent recognized the unconventional and advantageous nature of using a non-contact sensor to monitor the process of extraction and collection, and a wireless transmitter to convey information related to extracted and collected milk. The improved systems and methods of the ’619 Patent, recited in the claims, provide technological benefits over the prior art.

U.S. Design Patent No. D832,995

51. On November 6, 2018, the USPTO duly and lawfully issued the ’D995 Patent, entitled “Breast pump.” A true and correct copy of the ’D995 Patent is attached as Exhibit 7. By assignment, duly recorded with the USPTO, Willow owns all substantial rights to the ’D995 Patent, including the right to sue and recover damages for all infringement.

52. The ’D995 Patent is an ornamental design for a breast pump, as shown and described. Figure 1 provides an isometric view of the claimed breast pump:

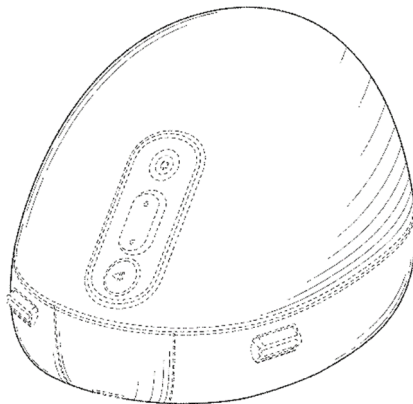

FIG. 1

U.S. Design Patent No. D977,625

53. On February 7, 2023, the USPTO duly and lawfully issued the 'D625 Patent, entitled "Breast pump." A true and correct copy of the 'D625 Patent is attached as Exhibit 8. By assignment, duly recorded with the USPTO, Willow owns all substantial rights to the 'D625 Patent, including the right to sue and recover damages for all infringement.

54. The 'D625 Patent is an ornamental design for a breast pump, as shown and described. Figure 1 provides an isometric view of the claimed breast pump:

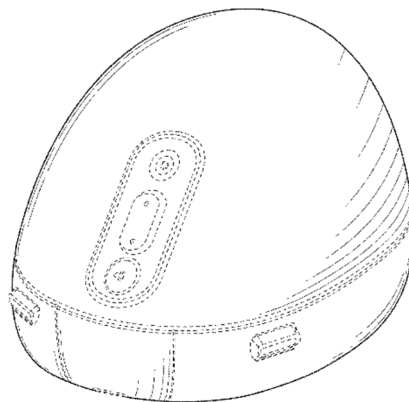

FIG. 1

THE ACCUSED PRODUCTS

55. Elvie infringed, and continues to directly infringe, each of the Asserted Patents in violation of 35 U.S.C. § 271(a) by making, using, selling, offering for sale in the United States, and/or importing into the United States, without authorization, products that practice the various claims of the Asserted Patents literally or under the doctrine of equivalents. Those products include, for example, the Elvie Pump and any mobile applications designed for use in conjunction with the Elvie Pump (collectively, the “Accused Products”).

COUNT I: INFRINGEMENT OF U.S. PATENT NO. 10,398,816

56. Willow incorporates by reference the proceeding paragraphs as if fully set forth herein.

57. Elvie has directly infringed, and continues to directly infringe, the ’816 Patent in violation of 35 U.S.C. § 271(a) by making, using, selling, offering for sale in the United States, and/or importing into the United States, without authorization, the Accused Products that practice various claims of the ’816 Patent literally or under the doctrine of equivalents.

58. Willow has complied with all statutory requirements, including the requirements of 35 U.S.C. § 287, to pursue and recover for any infringement of the ’816 Patent.

59. As a non-limiting example, the Accused Products meet every element of at least Claim 1 of the ’816 Patent literally or under the doctrine of equivalents. Claim 1 recites:

[preamble] An automated breast pump system for pumping milk from a breast of a user, comprising:

[1a] a breast pump configured to fit within a bra, the breast pump including:

[1b] a breast pump shell housing a milk flow path;

[1c] a pumping mechanism, the pumping mechanism contained completely within

the breast pump shell;

[1d] a fluid container configured to directly engage and be supported by the breast pump shell, wherein the fluid container is connected to the milk flow path;

[1e] a flange attached to the breast pump shell and configured to receive the breast, the flange including a rigid nipple receiving portion and a bottom portion, the bottom portion configured below the nipple receiving portion during use, the nipple receiving portion including a proximal end defining an opening; and

[1f] an external computer that automatically tracks pumping and communicates with the pumping mechanism;

[1g] wherein the pumping mechanism is associated with the rigid nipple receiving portion and the pumping mechanism is configured to create a suction force from the rigid nipple receiving portion, the suction force and the milk flow path both being directed generally upward relative to the bottom portion of the flange.

60. Exhibit 9 to this Complaint is a claim chart showing a non-limiting example of how Elvie's breast pumps and applications satisfy Claim 1 literally or under the doctrine of equivalents. The components and functionality in this chart are representative of the components and functionality present in all Accused Products. Elvie thus directly infringed and continues to directly infringe each limitation of at least Claim 1 of the '816 Patent by making, using, selling, offering for sale in the United States, and/or importing into the United States, without authorization, the Accused Products.

61. On information and belief, Elvie has known about the '816 Patent since at least its issuance on September 3, 2019. Elvie's knowledge is due to at least (1) its presence in the breast pump market and status as Willow's competitor; (2) its monitoring of competitors' patent

applications and issued patents; (3) its claim that its Elvie Pump is substantially equivalent to the Willow Pump during FDA pre-market proceedings and (4) Willow's substantial and continuous practice of providing constructive notice of its patents on its website. On information and belief, competitors such as Elvie generally monitor the patent applications, issued patents, and litigation activity of one another.

62. For example, the '816 Patent was cited during the prosecution of Elvie's patent applications. *See* Exs. 10, 11 (U.S. Patent Nos. 11,413,380 and D954,933, assigned to Elvie, citing the '816 Patent). Accordingly, Elvie had pre-suit knowledge of the '816 Patent at least through its prosecution activities.

63. In the alternative, at least as of the filing date of this lawsuit, Elvie has had knowledge of the '816 Patent and knowledge of how Elvie and third parties infringe that patent.

64. Elvie's knowledge of the '816 Patent is sufficient to satisfy the knowledge element for induced, contributory, and willful infringement.

65. Elvie indirectly infringes at least Claim 1 of the '816 Patent in violation of 35 U.S.C. § 271(b) by taking active steps to encourage and facilitate direct infringement by third parties, including users, partners, affiliates, subsidiaries, and service providers, in the United States with knowledge and the specific intent that its efforts would result in the direct infringement of the '816 Patent. For example, Elvie actively induces infringement of the '816 Patent by designing, manufacturing, selling, or distributing the Accused Products and then training its customers and users on the use of those products and the accompanying mobile applications, including through the creation and dissemination of supporting materials, videos, instructions, product manuals, and technical information. <https://www.elvie.com/en-us/support/elvie-pump/using-elvie-pump-app/can-i-use-elvie-pump-without-the-app>. In addition, Elvie actively induces infringement of the

'816 Patent by instructing, encouraging, or requiring its subsidiaries and affiliates to make, use, sell, offer for sale in the United States, and import into the United States, without authorization, the Accused Products that practice various claims of the '816 Patent, such as the Elvie Pump that is used in combination with the corresponding mobile applications. Further, Elvie actively induces infringement of the '816 Patent through the creation and dissemination of promotional and marketing materials. <https://www.youtube.com/watch?v=EXumEnA5qAw&t=95s>. Elvie's active inducement is done with the knowledge and the specific intent that its efforts would result in the direct infringement of the '816 Patent.

66. Elvie also is liable for contributory infringement of the '816 Patent under 35 U.S.C. § 271(c) by selling or offering for sale the Accused Products and/or other components (e.g., breast pump accessories, mobile applications, etc.) in the United States and importing the Accused Products and/or other components (e.g., breast pump accessories, mobile applications, etc.) into the United States with knowledge that they are especially designed or adapted to operate in a manner that infringes the '816 Patent and are not a staple article or commodity of commerce suitable for substantial non-infringing use. Elvie contributes to infringement of the '816 Patent by, *inter alia*, promotion, and/or sales of the infringing Accused Products and/or other components (e.g., breast pump accessories, mobile applications, etc.) to third parties.

67. Elvie's infringement of the '816 Patent has been and continues to be willful. As described above, Elvie has had knowledge of the '816 Patent at least since its issuance on September 3, 2019. On its website, Willow has provided substantial and continuous notice to infringers such as Elvie regarding the Asserted Patents, and Willow has included in such notice an identification of Willow products that practice the Asserted Patents. Thus, as one of Willow's primary competitors, Elvie had actual knowledge of the '816 Patent or was willfully blind to its

existence. In the alternative, Elvie's infringement has been willful at least since the filing date of this lawsuit because it has deliberately continued to infringe the '816 Patent despite knowing of the patent and how Elvie infringes. Further, Willow has deliberately continued to encourage others' infringement of the '816 Patent, including by continuing to disseminate its marketing and technical materials to customers.

68. Elvie's acts of infringement have injured and damaged Willow and will continue to injure and damage Willow. Willow is therefore entitled to recover from Elvie the damages it has sustained as a result of Elvie's wrongful and continued acts in an amount to be proven at trial.

69. Elvie's infringement has damaged and will continue to damage Willow irreparably, and Willow has no adequate remedy at law for its injuries. In addition to actual damages, Willow is entitled to a permanent injunction enjoining Elvie from infringing the '816 Patent.

COUNT II: INFRINGEMENT OF U.S. PATENT NO. 10,434,228

70. Willow incorporates by reference the preceding paragraphs as if fully set forth herein.

71. Elvie has directly infringed, and continues to directly infringe, the '228 Patent in violation of 35 U.S.C. § 271(a) by making, using, selling, offering for sale in the United States, and/or importing into the United States, without authorization, the Accused Products that practice various claims of the '228 Patent literally or under the doctrine of equivalents.

72. Willow has complied with all statutory requirements, including the requirements of 35 U.S.C. § 287, to pursue and recover for any infringement of the '228 Patent.

73. As a non-limiting example, the Accused Products meet every element of at least Claim 1 of the '228 Patent literally or under the doctrine of equivalents. Claim 1 recites:

[preamble] An automated method of pumping milk from a breast, the method

comprising:

[1a] providing a breast pump system configured to fit within a bra, the breast pump system including a breast pump housing, a breast contacting structure, a milk flow path, and a collection container;

[1b] the milk flow path and the collection container contained within the breast pump housing;

[1c] forming a seal between the breast pump system and the breast; and

[1d] pumping milk expressed from the breast to the collection container;

[1e] wherein the milk is pumped from the breast to the collection container upwardly through the milk flow path relative to a bottom of the breast contacting structure.

74. Exhibit 12 to this Complaint is a claim chart showing a non-limiting example of how Elvie's breast pumps and applications satisfy Claim 1 literally or under the doctrine of equivalents. The components and functionality in this chart are representative of the components and functionality present in all Accused Products. Elvie thus directly infringed and continues to directly infringe each limitation of at least Claim 1 of the '228 Patent by making, using, selling, offering for sale in the United States, and/or importing into the United States, without authorization, the Accused Products.

75. On information and belief, Elvie has known about the '228 Patent since at least its issuance on October 8, 2019. Elvie's knowledge is due to at least (1) its presence in the breast pump market and status as Willow's competitor; (2) its monitoring of competitors' patent applications and issued patents; (3) its claim that its Elvie Pump is substantially equivalent to the Willow Pump during FDA pre-market proceedings; and (4) Willow's substantial and continuous

practice of providing constructive notice of its patents on its website. On information and belief, competitors such as Elvie generally monitor the patent applications, issued patents, and litigation activity of one another.

76. For example, the '228 Patent was cited during the prosecution of one or more of Elvie's patent applications. *See* Ex. 10 (U.S. Patent No. 11,413,380, assigned to Elvie, citing U.S. Pat. App. Pub. No. 2018/0021490—the child application of the '228 Patent). Accordingly, Elvie had pre-suit knowledge of the '228 Patent at least through its prosecution activities.

77. In the alternative, at least as of the filing date of this lawsuit, Elvie has had knowledge of the '228 Patent and knowledge of how Elvie and third parties infringe that patent.

78. Elvie's knowledge of the '228 Patent is sufficient to satisfy the knowledge element for induced, contributory, and willful infringement.

79. Elvie indirectly infringes at least Claim 1 of the '228 Patent in violation of 35 U.S.C. § 271(b) by taking active steps to encourage and facilitate direct infringement by third parties, including users, partners, affiliates, subsidiaries, and service providers, in the United States with knowledge and the specific intent that its efforts would result in the direct infringement of the '228 Patent. For example, Elvie actively induces infringement of the '228 Patent by designing, manufacturing, selling, or distributing the Accused Products and then training its customers and users on the use of those products and the accompanying mobile applications, including through the creation and dissemination of supporting materials, videos, instructions, product manuals, and technical information. <https://www.elvie.com/en-us/support/elvie-pump/using-elvie-pump-app/can-i-use-elvie-pump-without-the-app>. In addition, Elvie actively induces infringement of the '228 Patent by instructing, encouraging, or requiring its subsidiaries and affiliates to make, use, sell, offer for sale in the United States, and import into the United States, without authorization,

the Accused Products that practice various claims of the '228 Patent, such as the Elvie Pump that is used in combination with the corresponding mobile applications. Further, Elvie actively induces infringement of the '228 Patent through the creation and dissemination of promotional and marketing materials. <https://www.youtube.com/watch?v=EXumEnA5qAw&t=95s>. Elvie's active inducement is done with the knowledge and the specific intent that its efforts would result in the direct infringement of the '228 Patent.

80. Elvie also is liable for contributory infringement of the '228 Patent under 35 U.S.C § 271(c) by selling or offering for sale the Accused Products and/or other components (e.g., breast pump accessories, mobile applications, etc.) in the United States and importing the Accused Products and/or other components (e.g., breast pump accessories, mobile applications, etc.) into the United States with knowledge that they are especially designed or adapted to operate in a manner that infringes the '228 Patent and are not a staple article or commodity of commerce suitable for substantial non-infringing use. Elvie contributes to infringement of the '228 Patent by, *inter alia*, promotion, and/or sales of the infringing Accused Products and/or other components (e.g., breast pump accessories, mobile applications, etc.) to third parties.

81. Elvie's infringement of the '228 Patent has been and continues to be willful. As described above, Elvie has had knowledge of the '228 Patent at least since its issuance on October 8, 2019. On its website, Willow has provided substantial and continuous notice to infringers such as Elvie regarding the Asserted Patents, and Willow has included in such notice an identification of Willow products that practice the Asserted Patents. Thus, as one of Willow's primary competitors, Elvie had actual knowledge of the '228 Patent or was willfully blind to its existence. In the alternative, Elvie's infringement has been willful at least since the filing date of this lawsuit because it has deliberately continued to infringe the '228 Patent despite knowing of the patent and

how Elvie infringes. Further, Willow has deliberately continued to encourage others' infringement of the '228 Patent, including by continuing to disseminate its marketing and technical materials to customers.

82. Elvie's acts of infringement have injured and damaged Willow and will continue to injure and damage Willow. Willow is therefore entitled to recover from Elvie the damages it has sustained as a result of Elvie's wrongful and continued acts in an amount to be proven at trial.

83. Elvie's infringement has damaged and will continue to damage Willow irreparably, and Willow has no adequate remedy at law for its injuries. In addition to actual damages, Willow is entitled to a permanent injunction enjoining Elvie from infringing the '228 Patent.

COUNT III: INFRINGEMENT OF U.S. PATENT NO. 10,625,005

84. Willow incorporates by reference the preceding paragraphs as if fully set forth herein.

85. Elvie has directly infringed, and continues to directly infringe, the '005 Patent in violation of 35 U.S.C. § 271(a) by making, using, selling, offering for sale in the United States, and/or importing into the United States, without authorization, the Accused Products that practice various claims of the '005 Patent literally or under the doctrine of equivalents.

86. Willow has complied with all statutory requirements, including the requirements of 35 U.S.C. § 287, to pursue and recover for any infringement of the '005 Patent.

87. As a non-limiting example, the Accused Products meet every element of at least Claim 1 of the '005 Patent literally or under the doctrine of equivalents. Claim 1 recites:

[preamble] An automated system for controlling pumping cycles to pump milk from a human breast, the system comprising:

[1a] a breast pump configured to fit within a bra, the breast pump including:

[1b] a chassis;

[1c] an outer shell attached to the chassis;

[1d] a pump mechanism attached to the chassis between the outer shell and chassis;

[1e] a battery contained between the outer shell and chassis;

[1f] a circuit board contained between the outer shell and chassis;

[1g] a sensor electrically connected to the circuit board;

[1h] a removeable breast contacting structure configured to contact and form a seal with the breast, the breast contacting structure including a nipple receiving portion below the pump mechanism; and

[1i] a milk collection container;

[1j] wherein when the removable breast contacting structure is removed, the pump mechanism, battery and circuit board are positioned between the outer shell and the chassis;

[1k] wherein the pump mechanism comprises two drivers that displace a flexible member to generate vacuum pressure in the nipple receiving portion;

[1l] wherein the system further comprises a wireless transmitter transmitting a Bluetooth Low Energy signal containing milk volume collected data;

[1m] wherein the system further comprises a chip tracking usage sessions of the breast pump;

[1n] wherein the system further comprises a language protocol for two-way communication between the breast pump and an external device;

[1o] wherein the system further comprises a remote user interface including user control functionality;

[1p] wherein the system further comprises an internal pump memory within a chip and the wireless transmitter transmits pumped milk volume to the external device which displays the pumped milk volume of each breast;

[1q] wherein the remote user interface has an input for the human to adjust the breast pump with the external device.

88. Exhibit 13 to this Complaint is a claim chart showing a non-limiting example of how Elvie's breast pumps and applications satisfy Claim 1 literally or under the doctrine of equivalents. The components and functionality in this chart are representative of the components and functionality present in all Accused Products. Elvie thus directly infringed and continues to directly infringe each limitation of at least Claim 1 of the '005 Patent by making, using, selling, offering for sale in the United States, and/or importing into the United States, without authorization, the Accused Products.

89. On information and belief, Elvie has known about the '005 Patent since at least its issuance on April 21, 2020. Elvie's knowledge is due to at least (1) its presence in the breast pump market and status as Willow's competitor; (2) its monitoring of competitors' patent applications and issued patents; (3) its claim that its Elvie Pump is substantially equivalent to the Willow Pump during FDA pre-market proceedings; and (4) Willow's substantial and continuous practice of providing constructive notice of its patents on its website. On information and belief, competitors such as Elvie generally monitor the patent applications, issued patents, and litigation activity of one another.

90. For example, the '005 Patent was cited during the prosecution of Elvie's patent applications. *See* Exs. 10, 11 (U.S. Patent Nos. 11,413,380 and D954,933, assigned to Elvie, citing

the '005 Patent). Accordingly, Elvie had pre-suit knowledge of the '005 Patent at least through its prosecution activities.

91. In the alternative, at least as of the filing date of this lawsuit, Elvie has had knowledge of the '005 Patent and knowledge of how Elvie and third parties infringe that patent.

92. Elvie's knowledge of the '005 Patent is sufficient to satisfy the knowledge element for induced, contributory, and willful infringement.

93. Elvie indirectly infringes at least Claim 1 of the '005 Patent in violation of 35 U.S.C. § 271(b) by taking active steps to encourage and facilitate direct infringement by third parties, including users, partners, affiliates, subsidiaries, and service providers, in the United States with knowledge and the specific intent that its efforts would result in the direct infringement of the '005 Patent. For example, Elvie actively induces infringement of the '005 Patent by designing, manufacturing, selling, or distributing the Accused Products and then training its customers and users on the use of those products and the accompanying mobile applications, including through the creation and dissemination of supporting materials, videos, instructions, product manuals, and technical information. <https://www.elvie.com/en-us/support/elvie-pump/using-elvie-pump-app/can-i-use-elvie-pump-without-the-app>. In addition, Elvie actively induces infringement of the '005 Patent by instructing, encouraging, or requiring its subsidiaries and affiliates to make, use, sell, offer for sale in the United States, and import into the United States, without authorization, the Accused Products that practice various claims of the '005 Patent, such as the Elvie Pump that is used in combination with the corresponding mobile applications. Further, Elvie actively induces infringement of the '005 Patent through the creation and dissemination of promotional and marketing materials. <https://www.youtube.com/watch?v=EXumEnA5qAw&t=95s>. Elvie's

active inducement is done with the knowledge and the specific intent that its efforts would result in the direct infringement of the '005 Patent.

94. Elvie also is liable for contributory infringement of the '005 Patent under 35 U.S.C § 271(c) by selling or offering for sale the Accused Products and/or other components (e.g., breast pump accessories, mobile applications, etc.) in the United States and importing the Accused Products and/or other components (e.g., breast pump accessories, mobile applications, etc.) into the United States with knowledge that they are especially designed or adapted to operate in a manner that infringes the '005 Patent and are not a staple article or commodity of commerce suitable for substantial non-infringing use. Elvie contributes to infringement of the '005 Patent by, *inter alia*, promotion, and/or sales of the infringing Accused Products and/or other components (e.g., breast pump accessories, mobile applications, etc.) to third parties.

95. Elvie's infringement of the '005 Patent has been and continues to be willful. As described above, Elvie has had knowledge of the '005 Patent at least since its issuance on April 21, 2020. On its website, Willow has provided substantial and continuous notice to infringers such as Elvie regarding the Asserted Patents, and Willow has included in such notice an identification of Willow products that practice the Asserted Patents. Thus, as one of Willow's primary competitors, Elvie had actual knowledge of the '005 Patent or was willfully blind to its existence. In the alternative, Elvie's infringement has been willful at least since the filing date of this lawsuit because it has deliberately continued to infringe the '005 Patent despite knowing of the patent and how Elvie infringes. Further, Willow has deliberately continued to encourage others' infringement of the '005 Patent, including by continuing to disseminate its marketing and technical materials to customers.

96. Elvie's acts of infringement have injured and damaged Willow and will continue to injure and damage Willow. Willow is therefore entitled to recover from Elvie the damages it has sustained as a result of Elvie's wrongful and continued acts in an amount to be proven at trial.

97. Elvie's infringement has damaged and will continue to damage Willow irreparably, and Willow has no adequate remedy at law for its injuries. In addition to actual damages, Willow is entitled to a permanent injunction enjoining Elvie from infringing the '005 Patent.

COUNT IV: INFRINGEMENT OF U.S. PATENT NO. 10,722,624

98. Willow incorporates by reference the preceding paragraphs as if fully set forth herein.

99. Elvie has directly infringed, and continues to directly infringe, the '624 Patent in violation of 35 U.S.C. § 271(a) by making, using, selling, offering for sale in the United States, and/or importing into the United States, without authorization, the Accused Products that practice various claims of the '624 Patent literally or under the doctrine of equivalents.

100. Willow has complied with all statutory requirements, including the requirements of 35 U.S.C. § 287, to pursue and recover for any infringement of the '624 Patent.

101. As a non-limiting example, the Accused Products meet every element of at least Claim 1 of the '624 Patent literally or under the doctrine of equivalents. Claim 1 recites:

[preamble] An automated system for controlling pumping cycles to pump milk from a human breast, the system comprising:

[1a] a breast pump shaped to fit within a bra, the breast pump including:

[1b] a housing sized to fit within the bra;

[1c] a breast adapter configured to contact and form a seal with the breast, the breast adapter being attached to the housing and including a nipple receiving cavity;

[1d] a pumping mechanism contained within the housing, the pumping mechanism including a pumping, region above the nipple receiving cavity;

[1e] a wireless transmitter;

[1f] a milk collection container configured to contact the bra;

[1g] a sensor which detects when the milk collection container is full;

[1h] an indicator light: and

[1i] a controller contained within the housing that automatically changes application of suction on the human breast through the nipple receiving cavity by the pumping mechanism from a letdown phase to an expression mode, wherein the controller automatically changes application of the suction from the letdown phase to the expression mode upon sensing a letdown.

102. Exhibit 14 to this Complaint is a claim chart showing a non-limiting example of how Elvie's breast pumps and applications satisfy Claim 1 literally or under the doctrine of equivalents. The components and functionality in this chart are representative of the components and functionality present in all Accused Products. Elvie thus directly infringed and continues to directly infringe each limitation of at least Claim 1 of the '624 Patent by making, using, selling, offering for sale in the United States, and/or importing into the United States, without authorization, the Accused Products.

103. On information and belief, Elvie has known about the '624 Patent since at least its issuance on July 28, 2020. Elvie's knowledge is due to at least (1) its presence in the breast pump market and status as Willow's competitor; (2) its monitoring of competitors' patent applications and issued patents; (3) its claim that its Elvie Pump is substantially equivalent to the Willow Pump during FDA pre-market proceedings; and (4) Willow's substantial and continuous practice of

providing constructive notice of its patents on its website. On information and belief, competitors such as Elvie generally monitor the patent applications, issued patents, and litigation activity of one another.

104. For example, the '624 Patent was cited during the prosecution of one or more of Elvie's patent applications. *See* Ex. 10 (U.S. Patent No. 11,413,380, assigned to Elvie, citing U.S. Pat. App. Pub. No. 2016/0310650—the parent application of the '624 Patent). Accordingly, Elvie had pre-suit knowledge of the '624 Patent at least through its prosecution activities.

105. In the alternative, at least as of the filing date of this lawsuit, Elvie has had knowledge of the '624 Patent and knowledge of how Elvie and third parties infringe that patent.

106. Elvie's knowledge of the '624 Patent is sufficient to satisfy the knowledge element for induced, contributory, and willful infringement.

107. Elvie indirectly infringes at least Claim 1 of the '624 Patent in violation of 35 U.S.C. § 271(b) by taking active steps to encourage and facilitate direct infringement by third parties, including users, partners, affiliates, subsidiaries, and service providers, in the United States with knowledge and the specific intent that its efforts would result in the direct infringement of the '624 Patent. For example, Elvie actively induces infringement of the '624 Patent by designing, manufacturing, selling, or distributing the Accused Products and then training its customers and users on the use of those products and the accompanying mobile applications, including through the creation and dissemination of supporting materials, videos, instructions, product manuals, and technical information. *See, e.g.*, <https://www.elvie.com/en-us/support/elvie-pump/using-elvie-pump-app/can-i-use-elvie-pump-without-the-app>. In addition, Elvie actively induces infringement of the '624 Patent by instructing, encouraging, or requiring its subsidiaries and affiliates to make, use, sell, offer for sale in the United States, and

import into the United States, without authorization, the Accused Products that practice various claims of the '624 Patent, such as the Elvie Pump that is used in combination with the corresponding mobile applications. Further, Elvie actively induces infringement of the '624 Patent through the creation and dissemination of promotional and marketing materials.

<https://www.youtube.com/watch?v=EXumEnA5qAw&t=95s>. Elvie's active inducement is done with the knowledge and the specific intent that its efforts would result in the direct infringement of the '624 Patent.

108. Elvie also is liable for contributory infringement of the '624 Patent under 35 U.S.C § 271(c) by selling or offering for sale the Accused Products and/or other components (e.g., breast pump accessories, mobile applications, etc.) in the United States and importing the Accused Products and/or other components (e.g., breast pump accessories, mobile applications, etc.) into the United States with knowledge that they are especially designed or adapted to operate in a manner that infringes the '624 Patent and are not a staple article or commodity of commerce suitable for substantial non-infringing use. Elvie contributes to infringement of the '624 Patent by, *inter alia*, promotion, and/or sales of the infringing Accused Products and/or other components (e.g., breast pump accessories, mobile applications, etc.) to third parties.

109. Elvie's infringement of the '624 Patent has been and continues to be willful. As described above, Elvie has had knowledge of the '624 Patent at least since its issuance on July 28, 2020. On its website, Willow has provided substantial and continuous notice to infringers such as Elvie regarding the Asserted Patents, and Willow has included in such notice an identification of Willow products that practice the Asserted Patents. Thus, as one of Willow's primary competitors, Elvie had actual knowledge of the '624 Patent or was willfully blind to its existence. In the alternative, Elvie's infringement has been willful at least since the filing date of this lawsuit

because it has deliberately continued to infringe the '624 Patent despite knowing of the patent and how Elvie infringes. Further, Willow has deliberately continued to encourage others' infringement of the '624 Patent, including by continuing to disseminate its marketing and technical materials to customers.

110. Elvie's acts of infringement have injured and damaged Willow and will continue to injure and damage Willow. Willow is therefore entitled to recover from Elvie the damages it has sustained as a result of Elvie's wrongful and continued acts in an amount to be proven at trial.

111. Elvie's infringement has damaged and will continue to damage Willow irreparably, and Willow has no adequate remedy at law for its injuries. In addition to actual damages, Willow is entitled to a permanent injunction enjoining Elvie from infringing the '624 Patent.

COUNT V: INFRINGEMENT OF U.S. PATENT NO. 11,185,619

112. Willow incorporates by reference the preceding paragraphs as if fully set forth herein.

113. Elvie has directly infringed, and continues to directly infringe, the '619 Patent in violation of 35 U.S.C. § 271(a) by making, using, selling, offering for sale in the United States, and/or importing into the United States, without authorization, the Accused Products that practice various claims of the '619 Patent literally or under the doctrine of equivalents.

114. Willow has complied with all statutory requirements, including the requirements of 35 U.S.C. § 287, to pursue and recover for any infringement of the '619 Patent.

115. As a non-limiting example, the Accused Products meet every element of at least Claim 1 of the '619 Patent literally or under the doctrine of equivalents. Claim 1 recites:

[preamble] An automated system for controlling pumping cycles to pump milk from a human breast, the automated system comprising:

- [1a] a breast pump shaped to fit within a bra, the breast pump including:
- [1b] a housing;
- [1c] a vacuum pumping mechanism contained within the housing and configured to pump the milk from the human breast;
- [1d] a wireless transmitter;
- [1e] a skin contact member configured to contact and form a seal with the breast, the skin contact member attached to the housing and including a nipple receiving portion;
- [1f] a milk collection container having a rigid exterior surface configured to contact the bra; and
- [1g] a non-contact pressure sensor that measures vacuum levels within the automated system, the non-contact pressure sensor adjacent the nipple receiving portion.

116. Exhibit 15 to this Complaint is a claim chart showing a non-limiting example of how Elvie's breast pumps and applications satisfy Claim 1 literally or under the doctrine of equivalents. The components and functionality in this chart are representative of the components and functionality present in all Accused Products. Elvie thus directly infringed and continues to directly infringe each limitation of at least Claim 1 of the '619 Patent by making, using, selling, offering for sale in the United States, and/or importing into the United States, without authorization, the Accused Products.

117. On information and belief, Elvie has known about the '619 Patent since at least its issuance on November 30, 2021. Elvie's knowledge is due to at least (1) its presence in the breast pump market and status as Willow's competitor; (2) its monitoring of competitors' patent

applications and issued patents; (3) its claim that its Elvie Pump is substantially equivalent to the Willow Pump during FDA pre-market proceedings; and (4) Willow's substantial and continuous practice of providing constructive notice of its patents on its website. On information and belief, competitors such as Elvie generally monitor the patent applications, issued patents, and litigation activity of one another.

118. For example, the '619 Patent was cited during the prosecution of one or more of Elvie's patent applications. *See* Ex. 10 (U.S. Patent No. 11,413,380, assigned to Elvie, citing U.S. Pat. App. Pub. No. 2018/0021490—the parent application to the '619 Patent). Accordingly, Elvie had pre-suit knowledge of the '619 Patent at least through its prosecution activities.

119. In the alternative, at least as of the filing date of this lawsuit, Elvie has had knowledge of the '619 Patent and knowledge of how Elvie and third parties infringe that patent.

120. Elvie's knowledge of the '619 Patent is sufficient to satisfy the knowledge element for induced, contributory, and willful infringement.

121. Elvie indirectly infringes at least Claim 1 of the '619 Patent in violation of 35 U.S.C. § 271(b) by taking active steps to encourage and facilitate direct infringement by third parties, including users, partners, affiliates, subsidiaries, and service providers, in the United States with knowledge and the specific intent that its efforts would result in the direct infringement of the '619 Patent. For example, Elvie actively induces infringement of the '619 Patent by designing, manufacturing, selling, or distributing the Accused Products and then training its customers and users on the use of those products and the accompanying mobile applications, including through the creation and dissemination of supporting materials, videos, instructions, product manuals, and technical information. <https://www.elvie.com/en-us/support/elvie-pump/using-elvie-pump-app/can-i-use-elvie-pump-without-the-app>. In addition, Elvie actively induces infringement of the

'619 Patent by instructing, encouraging, or requiring its subsidiaries and affiliates to make, use, sell, offer for sale in the United States, and import into the United States, without authorization, the Accused Products that practice various claims of the '619 Patent, such as the Elvie Pump that is used in combination with the corresponding mobile applications. Further, Elvie actively induces infringement of the '619 Patent through the creation and dissemination of promotional and marketing materials. <https://www.youtube.com/watch?v=EXumEnA5qAw&t=95s>. Elvie's active inducement is done with the knowledge and the specific intent that its efforts would result in the direct infringement of the '619 Patent.

122. Elvie also is liable for contributory infringement of the '619 Patent under 35 U.S.C § 271(c) by selling or offering for sale the Accused Products and/or other components (e.g., breast pump accessories, mobile applications, etc.) in the United States and importing the Accused Products and/or other components (e.g., breast pump accessories, mobile applications, etc.) into the United States with knowledge that they are especially designed or adapted to operate in a manner that infringes the '619 Patent and are not a staple article or commodity of commerce suitable for substantial non-infringing use. Elvie contributes to infringement of the '619 Patent by, *inter alia*, promotion, and/or sales of the infringing Accused Products and/or other components (e.g., breast pump accessories, mobile applications, etc.) to third parties.

123. Elvie's infringement of the '619 Patent has been and continues to be willful. As described above, Elvie has had knowledge of the '619 Patent at least since its issuance on November 30, 2021. On its website, Willow has provided substantial and continuous notice to infringers such as Elvie regarding the Asserted Patents, and Willow has included in such notice an identification of Willow products that practice the Asserted Patents. Thus, as one of Willow's primary competitors, Elvie had actual knowledge of the '619 Patent or was willfully blind to its

existence. In the alternative, Elvie's infringement has been willful at least since the filing date of this lawsuit because it has deliberately continued to infringe the '619 Patent despite knowing of the patent and how Elvie infringes. Further, Willow has deliberately continued to encourage others' infringement of the '619 Patent, including by continuing to disseminate its marketing and technical materials to customers.

124. Elvie's acts of infringement have injured and damaged Willow and will continue to injure and damage Willow. Willow is therefore entitled to recover from Elvie the damages it has sustained as a result of Elvie's wrongful and continued acts in an amount to be proven at trial.

125. Elvie's infringement has damaged and will continue to damage Willow irreparably, and Willow has no adequate remedy at law for its injuries. In addition to actual damages, Willow is entitled to a permanent injunction enjoining Elvie from infringing the '619 Patent.

COUNT VI: INFRINGEMENT OF U.S. DESIGN PATENT NO. D832,995





126. Willow incorporates by reference the preceding paragraphs as if fully set forth herein.

127. Elvie has directly infringed, and continues to directly infringe, the 'D995 Patent in violation of 35 U.S.C. § 271(a) by making, using, selling, offering for sale in the United States, and/or importing into the United States, without authorization, the Accused Products that practice various claims of the 'D995 Patent literally or under the doctrine of equivalents.

128. Willow has complied with all statutory requirements, including the requirements of 35 U.S.C. § 287, to pursue and recover for any infringement of the 'D995 Patent.

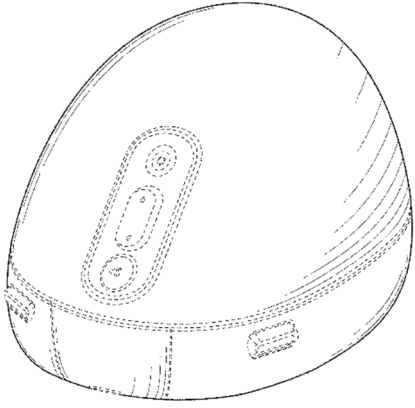
129. The 'D995 Patent claims the design as shown in the drawings contained therein. Each of the Accused Products is the same, or is substantially identical to, the design claimed in the 'D995 Patent as shown in the drawings contained therein. The following comparison of drawings

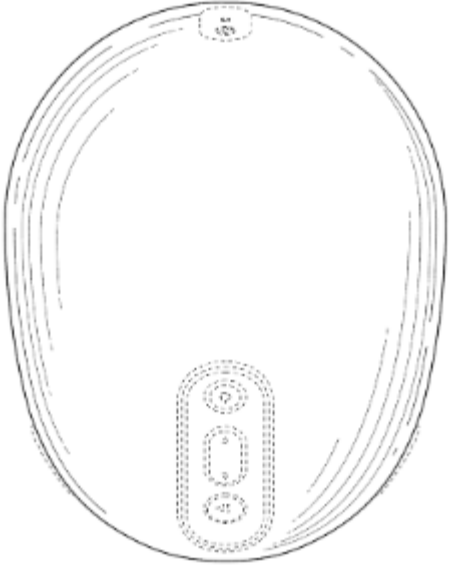
contained in the 'D995 Patent to the Accused Products shows that each of the Accused Products is the same, or is substantially identical to, the design claimed in the 'D995 Patent.

U.S. Patent No. D832,995	Elvie Pump
 <p data-bbox="375 873 440 898">FIG. 1</p>	
 <p data-bbox="431 1776 505 1801">FIG. 6</p>	



130. Comparing the drawings in the 'D995 patent with the Accused Products as shown above, an ordinary observer, with an understanding of the relevant prior art in breast pumps, would be deceived into believing that each of the Accused Products is the same as the patented design of the 'D995 patent. Each of the Accused Products is identical to, or substantially the same as, the patented design of the 'D995 Patent.

131. On information and belief, Elvie has known about the 'D995 Patent since at least its issuance on November 6, 2018. Elvie's knowledge is due to at least (1) its presence in the breast pump market and status as Willow's competitor; (2) its monitoring of competitors' patent applications and issued patents; (3) its claim that its Elvie Pump is substantially equivalent to the Willow Pump during FDA pre-market proceedings; and (4) Willow's substantial and continuous practice of providing constructive notice of its patents on its website. On information and belief, competitors such as Elvie generally monitor the patent applications, issued patents, and litigation activity of one another.

132. For example, the 'D995 Patent was cited during the prosecution of Elvie's patent applications. *See* Exs. 10, 11 (U.S. Patent Nos. 11,413,380 and D954,933, assigned to Elvie, citing

the 'D995 Patent). Accordingly, Elvie had pre-suit knowledge of the 'D995 Patent at least through its prosecution activities.

133. In the alternative, at least as of the filing date of this lawsuit, Elvie has had knowledge of the '995 Patent and knowledge of how Elvie and third parties infringe that patent.

134. Elvie's knowledge of the 'D995 Patent is sufficient to satisfy the knowledge element for induced, contributory, and willful infringement.

135. Elvie indirectly infringes at least Claim 1 of the 'D995 Patent in violation of 35 U.S.C. § 271(b) by taking active steps to encourage and facilitate direct infringement by third parties, including users, partners, affiliates, subsidiaries, and service providers, in the United States with knowledge and the specific intent that its efforts would result in the direct infringement of the 'D995 Patent. For example, Elvie actively induces infringement of the 'D995 Patent by designing, manufacturing, selling, or distributing the Accused Products and then training its customers and users on the use of those products and the accompanying mobile applications, including through the creation and dissemination of supporting materials, videos, instructions, product manuals, and technical information. <https://www.elvie.com/en-us/support/elvie-pump/using-elvie-pump-app/can-i-use-elvie-pump-without-the-app>. In addition, Elvie actively induces infringement of the 'D995 Patent by instructing, encouraging, or requiring its subsidiaries and affiliates to make, use, sell, offer for sale in the United States, and import into the United States, without authorization, the Accused Products that practice various claims of the 'D995 Patent, such as the Elvie Pump that is used in combination with the corresponding mobile applications. Further, Elvie actively induces infringement of the 'D995 Patent through the creation and dissemination of promotional and marketing materials. <https://www.youtube.com/watch?v=EXumEnA5qAw&t=95s>. Elvie's

active inducement is done with the knowledge and the specific intent that its efforts would result in the direct infringement of the 'D995 Patent.

136. Elvie also is liable for contributory infringement of the 'D995 Patent under 35 U.S.C § 271(c) by selling or offering for sale the Accused Products and/or other components (e.g., breast pump accessories, mobile applications, etc.) in the United States and importing the Accused Products and/or other components (e.g., breast pump accessories, mobile applications, etc.) into the United States with knowledge that they are especially designed or adapted to operate in a manner that infringes the 'D995 Patent and are not a staple article or commodity of commerce suitable for substantial non-infringing use. Elvie contributes to infringement of the 'D995 Patent by, *inter alia*, promotion, and/or sales of the infringing Accused Products and/or other components (e.g., breast pump accessories, mobile applications, etc.) to third parties.

137. Elvie's infringement of the 'D995 Patent has been and continues to be willful. As described above, Elvie has had knowledge of the 'D995 Patent at least since its issuance on November 6, 2018. On its website, Willow has provided substantial and continuous notice to infringers such as Elvie regarding the Asserted Patents, and Willow has included in such notice an identification of Willow products that practice the Asserted Patents. Thus, as one of Willow's primary competitors, Elvie had actual knowledge of the 'D995 Patent or was willfully blind to its existence. In the alternative, Elvie's infringement has been willful at least since the filing date of this lawsuit because it has deliberately continued to infringe the 'D995 Patent despite knowing of the patent and how Elvie infringes. Further, Willow has deliberately continued to encourage others' infringement of the 'D995 Patent, including by continuing to disseminate its marketing and technical materials to customers.

138. Elvie's acts of infringement have injured and damaged Willow and will continue to injure and damage Willow. Willow is therefore entitled to recover from Elvie the damages it has sustained as a result of Elvie's wrongful and continued acts in an amount to be proven at trial.

139. Elvie's infringement has damaged and will continue to damage Willow irreparably, and Willow has no adequate remedy at law for its injuries. In addition to actual damages, Willow is entitled to a permanent injunction enjoining Elvie from infringing the 'D995 Patent.



COUNT VII: INFRINGEMENT OF U.S. DESIGN PATENT NO. D977,625

140. Willow incorporates by reference the proceeding paragraphs as if fully set forth herein.

141. Elvie has directly infringed, and continues to directly infringe, the 'D625 Patent in violation of 35 U.S.C. § 271(a) by making, using, selling, offering for sale in the United States, and/or importing into the United States, without authorization, the Accused Products that practice various claims of the 'D625 Patent literally or under the doctrine of equivalents.

142. Willow has complied with all statutory requirements, including the requirements of 35 U.S.C. § 287, to pursue and recover for any infringement of the 'D625 Patent.

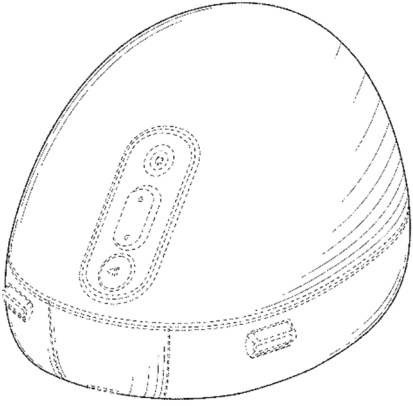
143. The 'D625 Patent claims the design as shown in the drawings contained therein. Each of the Accused Products is the same, or is substantially identical to, the design claimed in the 'D625 Patent as shown in the drawings contained therein. The following comparison of drawings contained in the 'D625 Patent to the Accused Products shows that each of the Accused Products is the same, or is substantially identical to, the design claimed in the 'D625 Patent.

U.S. Patent No. D977,625	Elvie Pump
 <p data-bbox="375 726 440 751">FIG. 1</p>	

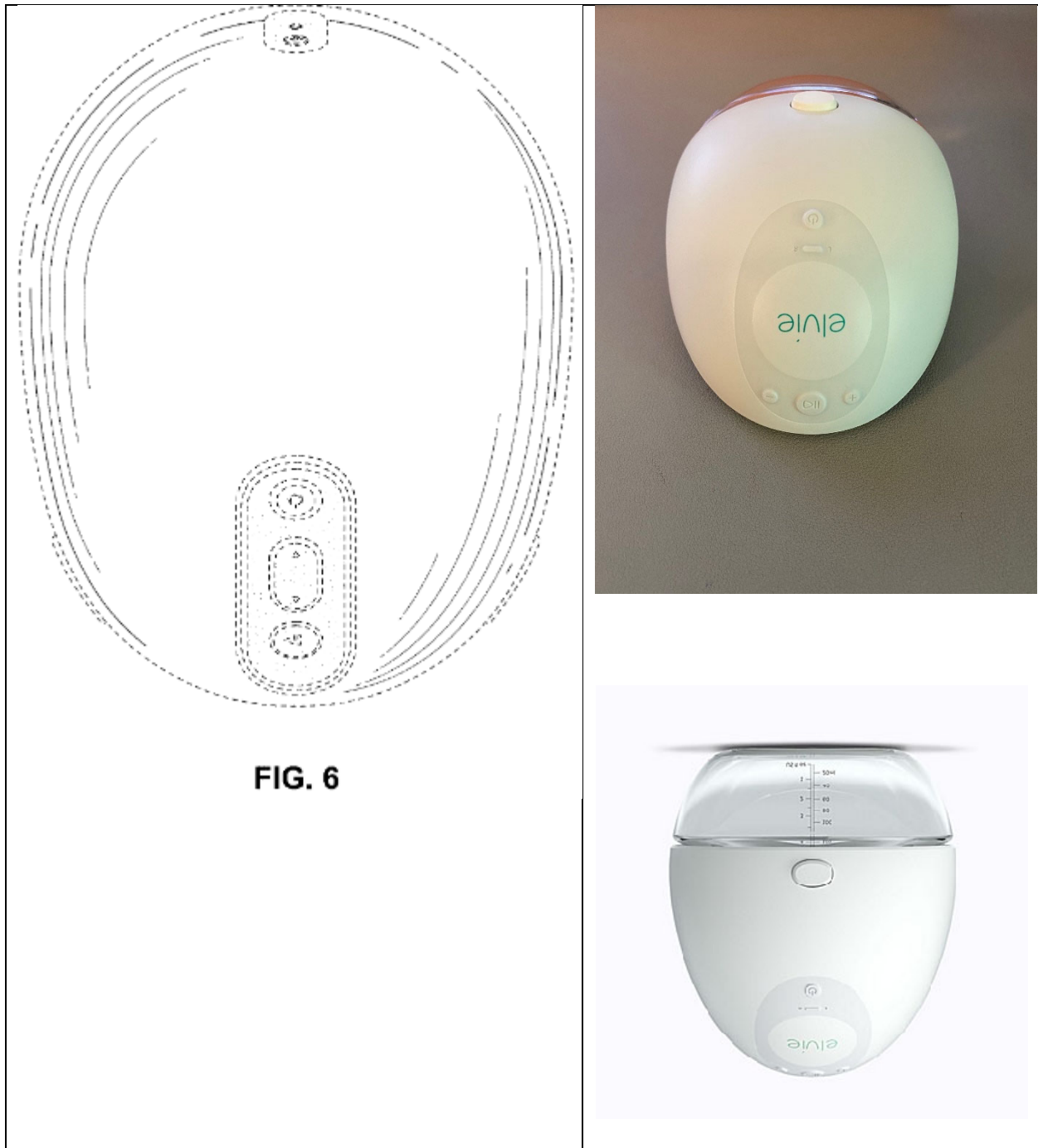

144. Comparing the drawings in the 'D625 patent with the Accused Products as shown above, an ordinary observer, with an understanding of the relevant prior art in breast pumps, would be deceived into believing that each of the Accused Products is the same as the patented design of

the 'D995 patent. Each of the Accused Products is identical to, or substantially the same as, the patented design of the 'D625 Patent.

145. On information and belief, Elvie has known about the 'D625 Patent since at least its issuance on February 7, 2023. Elvie's knowledge is due to at least (1) its presence in the breast pump market and status as Willow's competitor; (2) its monitoring of competitors' patent applications and issued patents; (3) its claim that its Elvie Pump is substantially equivalent to the Willow Pump during FDA pre-market proceedings; and (4) Willow's substantial and continuous practice of providing constructive notice of its patents on its website. On information and belief, competitors such as Elvie generally monitor the patent applications, issued patents, and litigation activity of one another.

146. For example, the 'D625 Patent was cited during the prosecution of Elvie's patent applications. *See* Exs. 10, 11 (U.S. Patent Nos. 11,413,380 and D954,933, assigned to Elvie, citing U.S. Design Patent No. D832,995—the parent patent to the 'D625 Patent). Accordingly, Elvie had pre-suit knowledge of the '624 Patent at least through its prosecution activities.

147. In the alternative, at least as of the filing date of this lawsuit, Elvie has had knowledge of the 'D625 Patent and knowledge of how Elvie and third parties infringe that patent.

148. Elvie's knowledge of the 'D625 Patent is sufficient to satisfy the knowledge element for induced, contributory, and willful infringement.

149. Elvie indirectly infringes at least Claim 1 of the 'D625 Patent in violation of 35 U.S.C. § 271(b) by taking active steps to encourage and facilitate direct infringement by third parties, including users, partners, affiliates, subsidiaries, and service providers, in the United States with knowledge and the specific intent that its efforts would result in the direct infringement of the '625 Patent. For example, Elvie actively induces infringement of the 'D625 Patent by designing,

manufacturing, selling, or distributing the Accused Products and then training its customers and users on the use of those products and the accompanying mobile applications, including through the creation and dissemination of supporting materials, videos, instructions, product manuals, and technical information. <https://www.elvie.com/en-us/support/elvie-pump/using-elvie-pump-app/can-i-use-elvie-pump-without-the-app>. In addition, Elvie actively induces infringement of the 'D625 Patent by instructing, encouraging, or requiring its subsidiaries and affiliates to make, use, sell, offer for sale in the United States, and import into the United States, without authorization, the Accused Products that practice various claims of the 'D625 Patent, such as the Elvie Pump that is used in combination with the corresponding mobile applications. Further, Elvie actively induces infringement of the 'D625 Patent through the creation and dissemination of promotional and marketing materials. <https://www.youtube.com/watch?v=EXumEnA5qAw&t=95s>. Elvie's active inducement is done with the knowledge and the specific intent that its efforts would result in the direct infringement of the 'D625 Patent.

150. Elvie also is liable for contributory infringement of the 'D625 Patent under 35 U.S.C § 271(c) by selling or offering for sale the Accused Products and/or other components (e.g., breast pump accessories, mobile applications, etc.) in the United States and importing the Accused Products and/or other components (e.g., breast pump accessories, mobile applications, etc.) into the United States with knowledge that they are especially designed or adapted to operate in a manner that infringes the 'D625 Patent and are not a staple article or commodity of commerce suitable for substantial non-infringing use. Elvie contributes to infringement of the 'D625 Patent by, *inter alia*, promotion, and/or sales of the infringing Accused Products and/or other components (e.g., breast pump accessories, mobile applications, etc.) to third parties.

151. Elvie's infringement of the 'D625 Patent has been and continues to be willful. As described above, Elvie has had knowledge of the 'D625 Patent at least since its issuance on April 21, 2020. On its website, Willow has provided substantial and continuous notice to infringers such as Elvie regarding the Asserted Patents, and Willow has included in such notice an identification of Willow products that practice the Asserted Patents. Thus, as one of Willow's primary competitors, Elvie had actual knowledge of the 'D625 Patent or was willfully blind to its existence. In the alternative, Elvie's infringement has been willful at least since the filing date of this lawsuit because it has deliberately continued to infringe the 'D625 Patent despite knowing of the patent and how Elvie infringes. Further, Willow has deliberately continued to encourage others' infringement of the 'D625 Patent, including by continuing to disseminate its marketing and technical materials to customers.

152. Elvie's acts of infringement have injured and damaged Willow and will continue to injure and damage Willow. Willow is therefore entitled to recover from Elvie the damages it has sustained as a result of Elvie's wrongful and continued acts in an amount to be proven at trial.

153. Elvie's infringement has damaged and will continue to damage Willow irreparably, and Willow has no adequate remedy at law for its injuries. In addition to actual damages, Willow is entitled to a permanent injunction enjoining Elvie from infringing the 'D625 Patent.

JURY DEMAND

154. Willow hereby demands a trial by jury on all issues.

PRAYER FOR RELIEF

Willow respectfully requests entry of judgment in its favor against Elvie as follows:

- a) Elvie has infringed, and continues to infringe, each of the Asserted Patents;
- b) An award of damages to Willow for such infringement, including enhanced

damages under 35 U.S.C. § 284 and prejudgment and post-judgment interest, without any limitation by 35 U.S.C § 287.

- c) An injunction against Elvie's infringement of the Asserted Patents;
- d) An order requiring Elvie to pay on-going royalties;
- e) An order finding that this is an exceptional case under 35 U.S.C. § 285 and an award to Willow of its attorneys' fees and costs in this action; and
- f) A judgment awarding all other costs and relief that the Court deems just and proper.

Dated: May 24, 2023

/s/ Timothy S. Durst

O'MELVENY & MYERS LLP

Timothy S. Durst (TX #00786924)

tdurst@omm.com

Cason Garrett Cole (TX #24109741)

ccole@omm.com

2501 North Harwood Street, Suite 1700

Dallas, TX 75201

Telephone: (972) 360-1900

Facsimile: (972) 360-1901

Robert F. Shaffer (*pro hac vice* forthcoming)

rshaffer@omm.com

Jason Fountain (*pro hac vice* forthcoming)

jfountain@omm.com

1625 Eye St., NW

Washington, DC 20006

Telephone: (202) 383-5300

Facsimile: (202) 383-5414

Carolyn S. Wall (*pro hac vice* forthcoming)

cwall@omm.com

Times Square Tower

7 Times Square

New York, New York 10036

Telephone: (212) 326-2000

Facsimile: (212) 326-2061

Laura Burson (TX #24091995)

lburson@omm.com

400 South Hope St

Los Angeles, CA 90071

Telephone: (213) 430-6000

Facsimile: (213) 430-6407

Attorneys for Plaintiff

WILLOW INNOVATIONS, INC.