

**IN THE UNITED STATES DISTRICT COURT
FOR THE EASTERN DISTRICT OF VIRGINIA
Alexandria Division**

SATTLER TECH CORPORATION,)
d/b/a Wali Electric, *a California*)
corporation,)

Plaintiff,)

JURY TRIAL DEMANDED

v.)

Civil Action No. _____

YAQI LYU, *an individual*; NINGBO)
KAIRUI ZHAOZHI TRADING)
COMPANY, LTD., *a foreign*)
corporation; HAVEN FURNITURE)
CO., LTD., *a foreign corporation*; U.S.)
PATENT NO. D853,403, a United)
States patent; and U.S. PATENT NO.)
D910,645, *a United States patent,*)

Defendants.)

COMPLAINT

1. Plaintiff Sattler Tech Corporation d/b/a Wali Electric (“Wali”) brings this suit for, *inter alia*, declaratory judgment of non-infringement and to establish the invalidity of two U.S. design patents, D910,645 (“645 Design Patent”) and D853,403 (“403 Design Patent”), which were purportedly assigned by Defendant Yaqi Lyu to various corporations controlled by him, based on Defendants’ malicious and inequitable conduct and fraud, as set forth herein. Further, Plaintiff Wali includes herein the “645 and the “403 patents in rem both as patent reside in this district making adjudication of the related issues more efficient and timely.

PARTIES

2. Plaintiff Sattler Tech Corporation d/b/a Wali Electric is a corporation organized under the laws of California with a principal place of business of 32108 Alvarado Blvd., #204, Union City, California 94587.

3. On information and belief, Defendant Yaqi Lyu is a citizen of Shenzhen, China. Upon information and belief, Defendant resides at Room 1612, Building Dongming, Minkang Road, Minzhi Street, Longhua District, Shenzhen City 518131 and has an email address of henry9190065@163.com.

4. Defendant Ningbo Kairui Zhaozhi Trading Company, Ltd. is a Chinese corporation with its principal place of business at Room 401-22, Number 17, Building 17, Zhongwu Science and Technology Park, Yinzhou District, Ningbo, Zhejiang, China. Pursuant to 35 U.S.C. § 293, it may be served at Chew Patents Group, 28039 Scott Road, Suite D-180, Murrieta, California, 92563.

5. Defendant Haven Furniture Company, Ltd. is a Chinese corporation with its principal place of business at Flat C 23/F Lucky Plaza, 315-321 Lockhart Road, Wan Chai, Hong King, China.

6. United States Patent Number D910,645 is a design patent published by the United States Patent and Trademark Office on or about February 16, 2021. Pursuant to 35 U.S.C. § 293, it may be served at Chew Patents Group, 28039 Scott Road, Suite D-180, Murrieta, California, 92563.

7. United States Patent Number D853,403 is a design patent published by the United States Patent and Trademark Office on or about July 9, 2019. Pursuant to 35 U.S.C. § 293, it may be served at Chew Patents Group, 28039 Scott Road, Suite D-180, Murrieta, California, 92563.

JURISDICTION AND VENUE

8. This Court has subject matter jurisdiction over this matter pursuant to Title 35 of the United States Code, and under 28 U.S.C. §§ 2201 and 2202, to obtain a declaration of non-infringement and invalidity with respect to the '645 and the '403 Design Patents. The Court also has pendent jurisdiction over state common law claims pursuant to 28 U.S.C. § 1367.

9. Venue is proper, *inter alia*, under 28 U.S.C. § 1391(b) because on information and belief, a substantial part of the events or omissions giving rise to the claim occurred in this judicial district, including but not limited to the filing of the sham assignments described below in the United States Patent and Trademark Office.

10. Personal jurisdiction exists over the corporate and individual Defendants because they conduct business in this judicial district, or otherwise avail themselves of the privileges and protections of the laws of the state of Virginia, such that this Court's assertion of jurisdiction over Defendants does not offend traditional notions of fair play and due process.

11. Personal jurisdiction also exists over the *in rem* Defendants because they are property having a situs within this district.

FACTUAL ALLEGATIONS

12. Wali sells a line of computer monitor, television, and speaker risers, stands, and mounts. The vast majority of its sales were made through its Amazon.com storefront. These products are highly rated by customers, with most items having close to a five-star rating.

13. Defendant Lyu had a business relationship with the factory that manufactures all of the Plaintiff's products and, as a result of this relationship, Defendant, Defendant's employees and/or agents had access to the factory in which the products described herein were manufactured.

14. Upon information and belief Defendant Lyu was able to access the designs of Plaintiff's products and used said designs to file for patents in both China and the United States even though Plaintiff had been selling the products in both jurisdictions. Further, upon information and belief, Defendant Lyu was aware of the Plaintiff's prior sales.

A. Wali's Products and Sales

15. Among the products Wali sells is an adjustable monitor riser stand (item model number STT003) for \$24.99. The monitor stand has rounded and beveled edges and a vented platform.



WALI Monitor Stand Riser for
Computer, Laptop, Printer,
Notebook and All Flat Screen
Display with Vented Metal Platfor...

★★★★☆ ~ 4,518

\$24⁹⁹

✓prime FREE One-Day

Get it **Tomorrow, Apr 7**

More Buying Choices

\$18.18 (4 used & new offers)

16. The Wali monitor stand was first offered for sale on Amazon on November 19, 2018.

17. The first Wali monitor stands were shipped to the United States from China by the manufacturer, Lumi Legend Corporation, on June 10, 2019, and arrived in Oakland, California on or about September 8, 2019.

18. The first Wali monitor stand was sold to a consumer through Amazon on September 28, 2019 at 2:05 PDT. Approximately two dozen sales of Wali monitor stands occurred between that date and October 18, 2019.

19. Wali also sells a support for television stand (item model number TVDVD-01) for \$19.99 (originally \$31.99 but price lowered to compete with Defendant's product). Wali's television stand is described as "WALI Universal TV Stand, Table Top TV Stand for 32 to 47 inch Flat TV, Height Adjustable

TV Mount with Tempered Glass Base and Security Wire, 88lbs Weight Capacity, VESA 400x400mm (TVDVD-01), Black”:

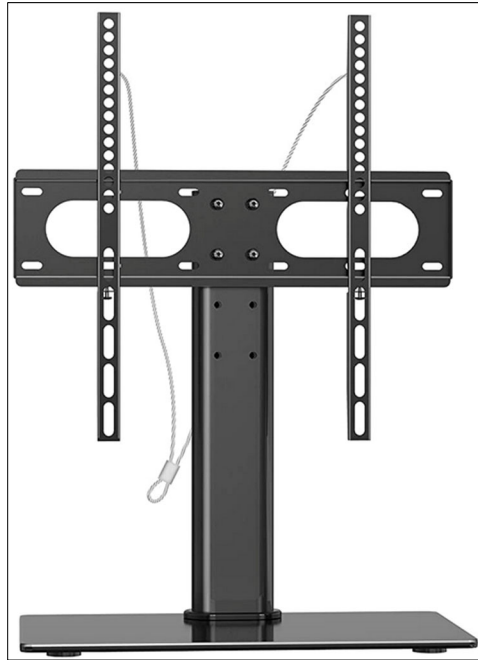

20. The Wali television stand was offered for sale on Amazon on June 6, 2017 with the first sale occurring on September 9, 2017.

details Order ID: # 111-1781396-3269843 Your Seller Order ID: # 111-1781396-3269843

order list

| summary | Ship to |
|--|--|
| e date: Sat, Sep 9, 2017, 8:47 AM PDT Fulfillment: Amazon | The shipping address is not displayed if an order is canceled. Contact Buyer: |

intents

| Image | Product name | More information | Unit price | Proceeds |
|---|---|--|------------|----------|
|  | WALI Universal Table Top TV Stand with Glass Base and Security Wire Fits 32-47" LED, LCD, Flat Screen TV, VESA up to 400x400 (TVDVD-01), Black ASIN: B071WN24YK SKU: TVDVD-01 | Listing ID: 0606560YHKE Order Item ID: 17864890137346 | \$31.99 | |

B. Lyu Fraudulently Obtains Design Patents

21. On March 10, 2021, Wali received a Policy Warning from Amazon, stating that Lyu (acting through counsel) had alleged that the monitor stand infringed the '645 Design Patent. As a result of this claim of infringement,

Wali's entire Amazon storefront was removed, which precluded it from selling the monitor stand and television stand through Amazon.

22. Lyu was aware that making a claim of patent infringement as to any product on Wali's storefront would cause Amazon to remove the entire storefront, precluding sales of any of Wali's products including the Wali television riser.

23. Lyu filed for the '645 Design Patent, "ornamental design for a table top monitor stand," on October 18, 2019, eleven months after Wali's monitor stand was offered for sale and three weeks after its first sale. The '645 Design Patent was not issued until February 16, 2021.

24. The ornamental design that constitutes the claim of the '645 Design Patent is substantially similar to Wali's monitor stand design, with rounded beveled edges and a vented platform:

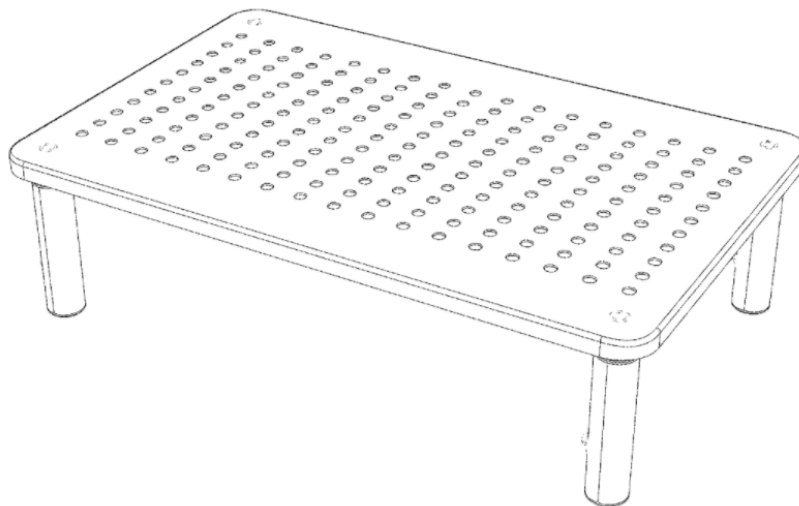

25. Lyu filed for the '403 Design Patent, entitled "SUPPORT FOR TELEVISION APPARATUS," on January 31, 2019 with application Serial No.

29/678,780. That date is 18 months after the Wali television stand was offered for sale and 16 months after it was first sold in commerce through Amazon. The '403 Design Patent was not issued until July 9, 2019.

26. The ornamental design that constitutes the claim of the '645 Design Patent (show below on the left) is substantially similar to Wali's television stand design (show below on the right).

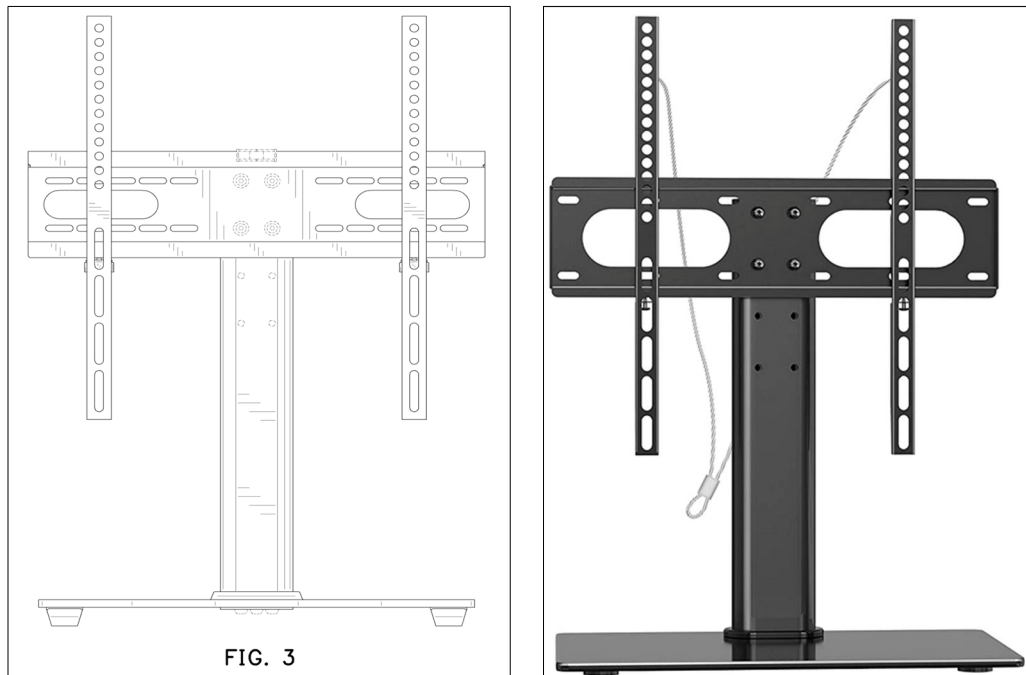

27. On information and belief, using the factory access provided by the joint venture agreement, Lyu illicitly obtained the Wali monitor and television stands in China prior to them being shipped to the United States. Defendant then filed design patent applications for nearly identical similar products.

28. Lyu did so despite knowing that Wali had offered the monitor stand and television stand for sale, and had actually sold monitor stands and television stands in commerce prior to the date that he filed for design patent protection for substantially similar products.

29. Such prior art sales activity was, on information and belief, intentionally not disclosed to the U.S. Patent and Trademark Office in connection with examination of the applications leading to the '645 Design Patent and '403 Design Patent.

30. On information and belief, Lyu's knowing and willful concealment of the prefiling sales activity from the U.S. Patent and Trademark Office in connection with the examination of the applications leading to the '645 Design Patent and '403 Design Patent constitutes inequitable conduct and fraud on the Patent Office.

31. Wali has not infringed and does not infringe, either directly or indirectly, any valid and enforceable claim of the '645 Design Patent or '403 Design Patent.

32. Wali was harmed by Lyu's filing for design patents on products that are substantially similar to products that were offered for sale and had actually been sold in commerce by Wali prior to the filing of materially false and misleading design patent applications.

33. Wali—which is a direct competitor of Lyu, the other Defendants, and of companies owned, operated, or controlled by Lyu—has been harmed by

Lyu's conduct in that Wali has lost sales of both the monitor stand and television stand because of the removal of Wali's Amazon store front. In addition, as a result of Lyu's knowingly false claim of design patent infringement, Wali has lost sales of other products that it offered for sale through its Amazon store front.

34. Defendant Haven Furniture Co., Ltd. is a corporation owned, operated, and/or controlled by Lyu, either directly or through intermediaries.

35. As a result of Lyu's fraudulent conduct, as set forth herein, Haven Furniture Co., Ltd. was enabled to sell and ship monitor stands and television stands manufactured pursuant to the fraudulently obtained design patents, without competition from Wali's products.

36. Lyu's fraudulent conduct, as set forth herein, was intended to benefit, and in fact conferred a direct benefit, on Defendant Haven Furniture Co., Ltd., to the detriment of Wali.

C. The Sham Patent Assignments

37. On or about April 15, 2021, Wali filed Case No. 1:21-cv-00471-PTG-LRV (hereinafter, the "471 Action") against Lyu in the Eastern District of Virginia, alleging *inter alia* a declaration of patent invalidity and non-infringement as to the '403 and '645 Design Patents, as well as state common law claims relating to Lyu's conduct.

38. Wali filed its Third Amended Complaint in this action on or about July 12, 2022. The Court sustained a motion to dismiss Counts 4-5 of this Third

Amended Complaint, but Counts 1-3 remain the operative allegations in the 471 Action.

39. On or about January 20, 2023, Lyu filed a motion to dismiss Counts 1 and 2 of the 471 Action, which sought a declaratory judgment of patent invalidity and non-infringement as to the '403 and '645 Design Patents. His grounds for so moving were that he had previously assigned the patents to new owners—one week and two-and-a-half months, respectively, after Wali filed its Third Amended Complaint in the 471 Action.

40. Lyu asserts that on or about September 30, 2022, he assigned the '403 Design Patent to Defendant Ningbo Kairui Zhaozhi Trading Co., Ltd. This assignment was filed with the U.S. Patent and Trademark Office on or about October 19, 2022 by attorneys working on Lyu's behalf and at his direction and control.

41. This assignment does not purport to identify any person or persons who owns, operates, or controls the assignee who purportedly received this assignment of patent rights, or to identify any corporate representative who acknowledged receipt of the assignment.

42. As such, the assignment bears indicia of fraud and collusion directly on its face. This indicia of fraud is strengthened by the fact that these assignments only took place after Wali filed its Third Amended Complaint in the 471 Action.

43. On information and belief, Lyu owns, operates, and/or controls a number of manufacturing, trading, and shipping companies within China. Lyu, on information and belief, often uses the names of employees, friends, and family members as owners, operators, and board members to hide his ownership interest and control in these companies.

44. On information and belief, the corporate entity Defendants, and each and every one, are among the companies that Lyu owns, operates, and controls either directly or through intermediaries.

45. The assignments purporting to assign ownership of the '403 Design Patent is a sham assignment and/or are collusive attempts by Lyu and the Defendant corporate entities to deprive the Court of jurisdiction in Case No. 1:21-cv-00471-PTG-LRV.

46. Upon the filing of this Complaint, Wali intends to move to join this action with Case No. 1:21-cv-00471-PTG-LRV.

COUNT 1

Declaratory Judgment of Sham and/or Collusive Patent Assignment (Against Defendants Lyu and Ningbo Kairui Zhaozhi Trading Company, Ltd.)

47. Plaintiff realleges the preceding paragraphs as if fully set forth herein.

48. As a result of the acts described herein, including but not limited to the sham and/or collusive assignments of patent ownership as set forth herein, a substantial controversy of sufficient immediacy and reality exists to warrant the issuance of a declaratory judgment.

49. Defendant Lyu entered, or caused to be entered, into the files of the United States Patent and Trademark Office, a sham and/or collusive assignment of the '403 Design Patent to Defendant Ningbo Kairui Zhaozhi Trading Company, Ltd.

50. This sham and/or collusive assignment was made for the sole purpose of depriving the Court of jurisdiction in Case No. 1:21-cv-00471-PTG-LRV in the Eastern District of Virginia.

51. This assignment was made with the knowledge of, for the benefit of, and with the cooperation of, Defendant Ningbo Kairui Zhaozhi Trading Company, Ltd.

52. Defendant Ningbo Kairui Zhaozhi Trading Company, Ltd. is owned, controlled, and operated by Defendant Lyu.

53. Wali has been harmed by this sham and/or collusive assignment of the '403 Design Patent.

54. Wali is entitled to a declaratory judgment that the Defendants entered or caused to be entered into the files of the United States Patent and Trademark Office a sham and/or collusive assignment of ownership of the '403 Design Patent.

COUNT 2
Declaratory Judgment of Non-Infringement and
Invalidity of the '645 Design Patent
(Against Defendant United States Patent Number D910,645)

55. Plaintiff realleges the preceding paragraphs as if fully set forth herein.

56. As a result of the acts described herein, including but not limited to the sham and/or collusive assignments of patent ownership as set forth herein, a substantial controversy of sufficient immediacy and reality exists to warrant the issuance of a declaratory judgment.

57. A judicial declaration is necessary and appropriate so that Wali may ascertain its rights regarding the '645 Design Patent.

58. Wali is entitled to a declaratory judgment that it has not infringed and does not infringe, directly or indirectly, any valid and enforceable claim of the '645 Design Patent.

59. Wali is entitled to a declaratory judgment that no claim of the '645 Design Patent is valid and enforceable for inequitable conduct and fraud.

COUNT 3
Declaratory Judgment of Non-Infringement and
Invalidity of the '403 Design Patent
(Against Defendant United States Patent Number D853,403)

60. Plaintiff realleges the preceding paragraphs as if fully set forth herein.

61. As a result of the acts described herein, including but not limited to the sham and/or collusive assignments of patent ownership as set forth herein, a substantial controversy of sufficient immediacy and reality exists to warrant the issuance of a declaratory judgment.

62. A judicial declaration is necessary and appropriate so that Wali may ascertain its rights regarding the '403 Design Patent.

63. Wali is entitled to a declaratory judgment that it has not infringed and does not infringe, directly or indirectly, any valid and enforceable claim of the '403 Design Patent.

64. Wali is entitled to a declaratory judgment that no claim of the '403 Design Patent is valid and enforceable for inequitable conduct and fraud.

COUNT 4
Unjust Enrichment
(Against Defendant Haven Furniture Company, Ltd.)

65. Plaintiff realleges the preceding paragraphs as if fully set forth herein.

66. As set forth herein, Wali conferred a benefit on Defendant.

67. Defendant knew of the benefit conferred on him by Wali and should reasonably have expected to repay Wali.

68. Defendant accepted or retained the benefit without paying for its value.

69. Wali reasonably expected to realize more than \$1,921,668.89 Million from the sale through Amazon of its monitor and television stand.

70. As a direct and proximate cause of Defendant's conduct as set forth herein, Wali has been damaged in an amount to be proven at trial, but in no event less than \$1,921,668.89 Million.

71. Defendant's conduct as set forth herein was fraudulent, intentional, and malicious, and as such Wali is entitled to punitive damages and reasonable costs and attorneys' fees to the extent permitted by lawWali

has lost sales and/or profits as a direct and proximate consequence of the conduct of Defendant as set forth herein, in an amount to be proven at trial, but in no event less than \$1,921,668.89 Million.

72. Because of the intentional, malicious, and fraudulent conduct as set forth herein, this is an exceptional case and Wali is entitled to an award of reasonable attorneys' fees and treble lost profits pursuant to 35 U.S.C. § 284.

PRAYER FOR RELIEF

73. WHEREFORE, Plaintiff respectfully requests the Court grant the following relief against Defendant:

- a) that the Court enter a declaratory judgment that the purported assignment of ownership of U.S. Patent No. D853,403 to Defendant Ningbo Kairui Zhaozhi Trading Company, Ltd. is invalid;
- b) that the Court enter a declaratory judgment that the claims of the Defendant's '645 Design Patent are invalid;
- c) that the Court enter a declaratory judgment that the claims of the Defendant's '403 Design Patent are invalid;
- d) that the Court enter a declaratory judgment that the claims of the Defendant's '645 Design Patent are unenforceable;
- e) that the Court enter a declaratory judgment that the claims of the Defendant's '403 Design Patent are unenforceable;

- f) that the Court enter a declaratory judgment that Plaintiff does not infringe and has not infringed, directly or indirectly, any claim of the Defendant's '645 Design Patent;
- g) that the Court enter a declaratory judgment that Plaintiff does not infringe and has not infringed, directly or indirectly, any claim of the Defendant's '403 Design Patent;
- h) that Defendants, and all persons acting on its behalf or in concert with them, be permanently enjoined and restrained from charging, orally or in writing, that the '645 Design Patent is infringed, directly or indirectly, by Wali;
- i) that Defendants, and all persons acting on their behalf or in concert with them, be permanently enjoined and restrained from charging, orally or in writing, that the '403 Design Patent is infringed, directly or indirectly, by Wali;
- j) that Wali be awarded \$1,921,668.89 million in lost profits plus such other damages as may be shown at trial;
- k) that Wali be awarded treble lost profits pursuant to 35 U.S.C. § 284;
- l) that Wali be awarded its costs, expenses, and reasonable attorneys' fees in this action; and
- m) any other legal or equitable relief to which Plaintiff may be entitled.

DATED: January 26, 2023

Respectfully submitted,

/s/ Jonathan Westreich, Esq.

Jonathan Westreich, Esq. (VSB No. 37393)
Greenberg & Lieberman, LLC (of counsel)
604 Cameron Street
Alexandria, Virginia 22314
Tel.: 703-299-9050
jonathan@westreichlaw.com

Stevan Lieberman, Esq. (not admitted in Virginia)
Michael Greenberg, Esq. (not admitted in Virginia)
Emanuel N. Mpras, Esq. (VSB No. 76065)
Greenberg & Lieberman, LLC
1775 Eye Street, Suite 1150
Washington, D.C. 20006
Tel.: (202) 625-7000
Fax: (202) 625-7001
Email: Stevan@aplegal.com

Attorneys for Plaintiff Sattler Tech Corporation d/b/a Wali Electric