

1 Brian R. Michalek (SBN 302007)
Casey T. Grabenstein (*pro hac vice* – to be filed)
2 Joseph M. Kuo (*pro hac vice* – to be filed)
SAUL EWING LLP
3 161 N. Clark St., Suite 4200
Chicago, IL 60601
4 Telephone: (312) 876-7100
Facsimile: (312) 876-0288
5 brian.michalek@saul.com
casey.grabenstein@saul.com
6 joseph.kuo@saul.com

7 Andrew Schwerin (*pro hac vice* – to be filed)
SAUL EWING LLP
8 Centre Square West
1500 Market Street, 38th Floor
9 Philadelphia, PA 19102 2186
Telephone: (215) 972-7184
10 Facsimile: (215) 972-7184
andrew.schwerin@saul.com

11 Michael E. Flynn-O’Brien (SBN 291301)
12 BUNSOW DE MORY LLP
701 El Camino Real
13 Redwood City, CA 94063
Telephone: (650) 351-7245
14 Facsimile: (415) 426-4744
mflynnobrien@bdiplaw.com

15 *Attorneys for Plaintiff InfoExpress Inc.*

16
17 **IN THE UNITED STATES DISTRICT COURT
FOR THE NORTHERN DISTRICT OF CALIFORNIA**

18 **INFOEXPRESS INC.**

19 Plaintiff,

20 v.

21 **CISCO SYSTEMS, INC.,**

22 Defendant.

Case No.

**COMPLAINT FOR PATENT
INFRINGEMENT**

DEMAND FOR JURY TRIAL

23
24 Plaintiff InfoExpress Inc. (“InfoExpress” or “Plaintiff”), by its undersigned counsel, for
its Complaint against Defendant Cisco Systems, Inc. (“Cisco” or “Defendant”), states as follows:

1 **I. NATURE OF THE ACTION**

2 1. This is a civil action arising under the patent laws of the United States, 35 U.S.C.
3 § 1 et seq., including 35 U.S.C. § 271, based on Cisco’s unauthorized and willfully infringing
4 manufacture, use, sale, offering for sale, and/or importation of products and the practicing of
5 methods incorporating InfoExpress’s patented inventions.

6 2. InfoExpress is owner of all right, title, and interest in and to multiple United
7 States patents including United States Patent Nos. 7,523,484 (the ’484 Patent); 8,051,460 (the
8 ’460 Patent); 8,677,450 (the ’450 Patent); 8,578,444 (the ’444 Patent); 8,347,350 (the ’350
9 Patent); and 8,117,645 (the ’645 Patent) (collectively, “the Patents-in-Suit”).

10 3. Cisco manufactures, makes, uses, provides, sells, offers for sale, imports, and/or
11 distributes products, services, and systems which directly infringe the Patents-in-Suit. The
12 Patents-in-Suit represent InfoExpress’s significant investment into the network access and
13 security space.

14 **II. THE PARTIES**

15 4. Plaintiff InfoExpress is a California corporation with its principal place of
16 business located at 2975 Bowers Ave #323, Santa Clara, CA 95051.

17 5. Defendant Cisco Systems, Inc. is a corporation that is organized under the laws of
18 Delaware and that has place of business located at 170 West Tasman Dr., San Jose, CA 95134.

19 **III. JURISDICTION AND VENUE**

20 6. This is an action for patent infringement, which arises under the Patent Laws of
21 the United States, in particular, 35 U.S.C. §§ 271, 281, 282, 284, and 285. This Court has
22 jurisdiction over the subject matter of this action under 28 U.S.C. §§ 1331 and 1338(a).

23 7. The Court has personal jurisdiction over Cisco because it is headquartered within
24 this judicial district and further because it has committed acts giving rise to this action within

1 California and within this District. Cisco also regularly does business or solicits business in this
2 District and in California, engages in other persistent course of conduct and derives substantial
3 revenue from products and/or services provided in this District and in California, and has
4 purposefully established substantial, systematic and continuous contacts with this District and
5 should reasonably expect to be sued in a court in this District.

6 8. Cisco has committed acts of patent infringement in this District and elsewhere in
7 California.

8 9. Venue is proper in this District under 28 U.S.C. §§ 1391 and 1400(b) because
9 Cisco has an established place of business in this District, including at 170 West Tasman Dr.,
10 San Jose, CA 95134, has committed acts within this District giving rise to this action and
11 resulting in the derivation of substantial revenue from goods and services provided to customers
12 in California, and continues to conduct business in this District, including one or more acts of
13 selling, using, importing, and/or offering for sale infringing goods and/or performing support
14 service to Cisco customers in this District.

15 **IV. INTRADISTRICT ASSIGNMENT**

16 10. Pursuant to Local Rule 3-2(c) and the Court's Assignment Plan (General Order
17 No. 44) D(3), intellectual property cases, such as this one, are assigned on a district-wide basis.

18 **V. FACTUAL ALLEGATIONS**

19 *InfoExpress's Innovations*

20 11. Established in 1993, InfoExpress is a privately held network security solutions
21 corporation with its offices in Santa Clara, California.

22 12. Since its inception, and leading up to its groundbreaking patented network access
23 control ("NAC") and endpoint compliance innovations, InfoExpress has been a pioneer in
24 designing and implementing foundational security technologies.

1 13. InfoExpress’s security innovation dates as early as the 1990s when it developed
2 Virtual Transmission Control Protocol (“VTCP”), a virtual application programming interface
3 (“API”) that allowed online dial-up accounts to run internet applications directly on user
4 personal computers.

5 14. VTCP was used by InfoExpress’s corporate customers to provide remote
6 employee access to corporate networks. This, however, required additional security.

7 15. In response, InfoExpress developed and introduced VTCP Secure in 1996. VTCP
8 Secure was a seminal approach to remote access Virtual Private Networks (“VPN”). Like its
9 predecessor, VTCP Secure was also tremendously popular and sales jumped exponentially. It
10 also garnered substantial industry praise.¹

11 16. As culture evolved, additional security measures were needed to protect corporate
12 resources from potentially compromised remote VPN-connected PCs. Thus, in or around 2000,
13 InfoExpress developed CyberArmor—a personal firewall that provided protection to the PCs.
14 Again, InfoExpress received praise and awards in the security industry for CyberArmor.

15 17. While CyberArmor was successful, InfoExpress customers reported that some
16 individual users did not install CyberArmor or disabled it. To address this issue, InfoExpress
17 innovated to develop a CyberGatekeeper Remote product and service which could be placed
18 between VPN servers and its corporate customer networks to monitor whether the CyberArmor
19 personal firewall was installed and active on the remote PC before granting access to the
20 corporate network.

21
22 _____
23 ¹ HelpNetSecurity, *Infoexpress VPN Software VTCP/Secure Chosen Windows & .Net Magazine*
24 *Readers’ Choice Award Winner*, <https://www.helpnetsecurity.com/2002/09/18/infoexpress-vpn-software-vtcpsecure-chosen-windows-net-magazine-readers-choice-award-winner/> (last visited May 18, 2023) (“VTCP/Secure 5.1 was selected a winner in the Best VPN category of the Windows & .NET Magazine Readers’ Choice Awards.”)

1 18. A shift in the security space came when companies started transitioning
2 employees from desktops to mobile devices such as laptops. While this expanded mobile
3 network connectivity and usage, it also increased corporate security risks. Because
4 CyberGatekeeper Remote was located behind VPN servers and because a corporate organization
5 provided access to the network with hundreds, if not, thousands of switches, adding extra
6 CyberGatekeeper Remote behind each switch was impractical.

7 19. Accordingly, in 2003, InfoExpress invented network access control through
8 insertion of a gatekeeper between access devices and the authentication servers via a new NAC
9 product. This product, called CyberGatekeeper LAN, was the world’s first network access
10 control product for the local area networks (“LAN”).

11 20. To date, InfoExpress continues to offer products and services in the network
12 security space. However, Defendant’s infringement and usurping of InfoExpress’s patented
13 technology have resulted in a loss of market share, loss of customers, and declining sales.

14 ***InfoExpress’s Patent Portfolio***

15 21. The InfoExpress patent portfolio includes several issued and enforceable United
16 States patents (“the Patent Portfolio”) directed to network security and access control. This
17 Patent Portfolio is a direct result from the innovation, ingenuity, and work of InfoExpress
18 personnel including Chief Executive Officer and inventor Stacey Lum.

19 22. The Patents-in-Suit are part of the Patent Portfolio and relate to specific core and
20 foundational inventions for, and associated with, NAC technology.

21 23. The Patent Portfolio, and the Patents-in-Suit solve technological problems that
22 existed relating to the capabilities of controlling access to computing networks in the face of
23 growing user demand for accessing secure networks over the Internet and from personal devices
24 such as laptop computers and other mobile devices.

1 24. On April 21, 2009, the '484 Patent entitled "Systems and Methods for Controlling
2 Network Access" was duly and legally issued by the United States Patent and Trademark Office.
3 A true and accurate copy of the '484 Patent is attached hereto as Exhibit A.

4 25. On November 1, 2011, the '460 Patent entitled "Systems and Methods for
5 Controlling Network Access" was duly and legally issued by the United States Patent and
6 Trademark Office. A true and accurate copy of the '460 Patent is attached hereto as Exhibit B.

7 26. On March 18, 2014, the '450 Patent entitled "Systems and Methods for
8 Controlling Network Access" was duly and legally issued by the United States Patent and
9 Trademark Office. A true and accurate copy of the '450 Patent is attached hereto as Exhibit C.

10 27. On November 5, 2013, the '444 Patent entitled "Systems and Methods of
11 Controlling Network Access" was duly and legally issued by the United States Patent and
12 Trademark Office. A true and accurate copy of the '444 Patent is attached hereto as Exhibit D.

13 28. On January 1, 2013, the '350 Patent entitled "Systems and Methods of
14 Controlling Network Access" was duly and legally issued by the United States Patent and
15 Trademark Office. A true and accurate copy of the '350 Patent is attached hereto as Exhibit E.

16 29. On February 14, 2012, the '645 Patent entitled "Systems and Methods of
17 Controlling Network Access" was duly and legally issued by the United States Patent and
18 Trademark Office. A true and accurate copy of the '645 Patent is attached hereto as Exhibit F.

19 30. The Patents-in-Suit are valid and enforceable.

20 31. At least as of the 2003 priority date, the inventions as claimed in the Patents-in-
21 Suit were novel, non-obvious, unconventional, and non-routine.

22 32. InfoExpress is the assignee of and owns all right, title, and interests in the Patents-
23 in-Suit, including the right to receive lost profits and/or a reasonable royalty, and recovery of any
24 and all other damages for all past and future infringement thereof.

33. To the extent 35 U.S.C. § 287 is applicable, the requirements have been satisfied with respect to the Patents-in-Suit.

Cisco’s Infringing Instrumentalities

34. Cisco has been making, using, selling, importing, and offering for sale hardware and software (including licenses) that implement or practice the Patents-in-Suit including those for and relating to its NAC products such as the Identity Services Engine (“ISE”) alone, and in combination with, Cisco products such as:

- Cisco’s wireless access points, including its Catalyst 9100 access points (including its 9136, 9196, 9164, 9162, 9130, 9120, 9115, 9105i, and 9105w models) and further including its Meraki cloud-controlled access points;
- Cisco’s Secure Network Servers (SNS) including its SNS 3615, 3655, and 3695; and
- Cisco’s routers, including those in its 9000-series, which implement ISE to the same extent as its other products.

(hereinafter, the “Accused Instrumentalities.”).

35. Cisco’s ISE is “an identity-based network access control and policy enforcement system. It functions as a common policy engine that enables endpoint access control and network device administration for enterprises.”

Cisco ISE Overview

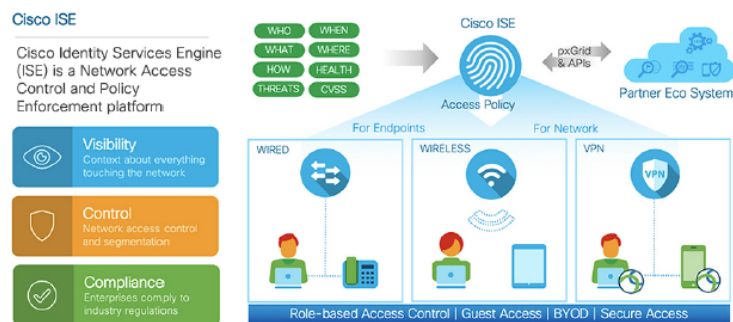

Cisco Identity Services Engine (ISE) is an identity-based network access control and policy enforcement system. It functions as a common policy engine that enables endpoint access control and network device administration for enterprises.

1 36. In particular, the Cisco ISE can be used to “control and audit the configuration of
2 network devices... Network devices can be configured to query Cisco ISE for authentication and
3 authorization of device administrator actions.”

4 Cisco ISE Features

- 5 • **Device Administration:** Cisco ISE uses the TACACS+ security protocol to control and audit the
6 configuration of network devices. It facilitates granular control of who can access which network device
7 and change the associated network settings. Network devices can be configured to query Cisco ISE for
8 authentication and authorization of device administrator actions. These devices also send accounting
9 messages to Cisco ISE to log such actions.
- 10 • **Posture or Compliance:** Cisco ISE allows you to check for compliance, also known as posture, of
11 endpoints, before allowing them to connect to your network. You can ensure that endpoints receive the
12 appropriate posture agents for posturing services.

13 37. As a security policy management platform, Cisco’s ISE “allows you to check for
14 compliance, also known as posture, of endpoints, before allowing them to connect to your
15 network.”

16 38. For authentication, Cisco’s ISE also interfaces with and controls access points –
17 such as those offered by Cisco and including routers or switches – to further network access
18 control. For example, ISE can use an Authorization VLAN (Virtual Local Area Network) as a
19 restricted space to confine a user endpoint device (e.g. laptop computer, smart phone, etc.) when
20 it connects to an access point. While the endpoint is confined, Cisco’s ISE can use its security
21 gatekeeper to assess the security posture of that device. Once the endpoint is found to meet
22 security requirements, ISE reconfigures the access point by assigning the endpoint to another
23 VLAN (e.g. Corporate VLAN) where the endpoint device will be able to access, and
24 communicate with, secure resources.

Figure 30: Auth VLAN Connected to Cisco ISE Node

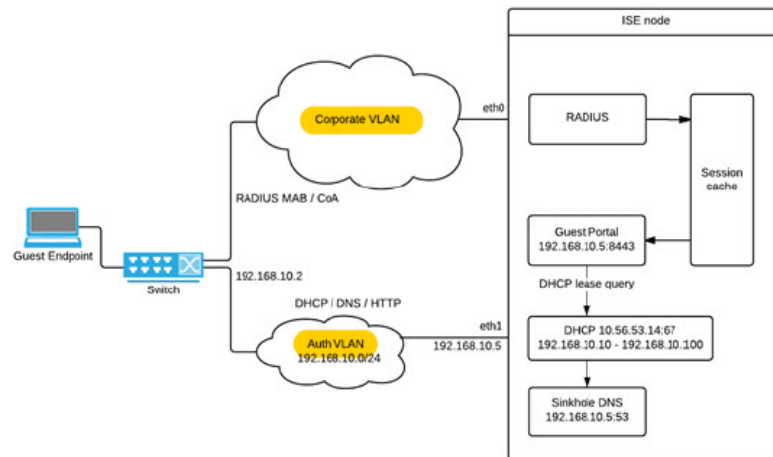

The following diagram displays a network with Auth VLAN and an IP helper.

Figure 31: Auth VLAN Configured with IP Helper

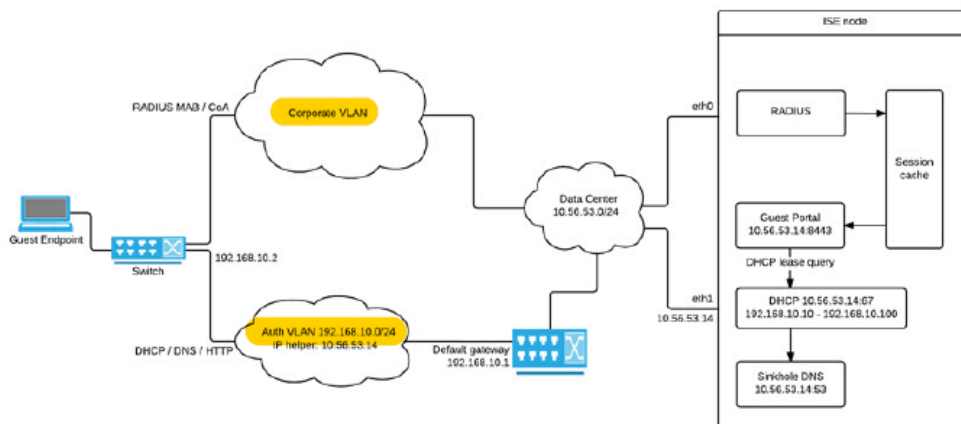

Cisco, *Identity Services Engine Administrator Guide, Release 3.0* (“ISE Admin Guide”), at 1, 2, 802-03, available at https://www.cisco.com/c/en/us/td/docs/security/ise/3-0/admin_guide/b_ISE_admin_3_0.pdf

39. Cisco itself practices the claimed inventions in the Patents-in-Suit, for example at its locations and campuses in this District and throughout the United States.

Cisco and InfoExpress Prior Relationship

40. In or around 2004, after the priority date of the patent portfolio, InfoExpress worked together with Cisco under the auspices of a relationship in which Cisco would help

1 commercialize InfoExpress’s NAC technology products—including its CyberGatekeeper LAN
2 product—through interoperability with Cisco’s routing, switching, security, wireless, and voice
3 products.

4 41. Through this arrangement, InfoExpress was asked to integrate its NAC
5 technology products with Cisco’s access point and infrastructure products. To do so, InfoExpress
6 was required to conduct a variety of testing, configuring, and analysis with respect to its NAC
7 technology products and to obtain Cisco’s approval.

8 42. Cisco eventually approved it, thus permitting InfoExpress to participate in
9 marketing activities, which resulted in substantial customer response and feedback with respect
10 to its NAC technology products.

11 43. This relationship and process also resulted in Cisco receiving this important and
12 valuable knowledge, technical expertise, customer feedback, and information concerning
13 InfoExpress’s NAC technology including that associated with the various NAC functionalities
14 for authentication, policy enforcement and posture compliance.

15 44. After receiving such valuable information regarding InfoExpress’s NAC
16 technology (and other third-party NAC products) and customer feedback, Cisco canceled its
17 arrangement with InfoExpress and substituted in its own NAC technology products that it had
18 been developing alongside which would be compliant with its Cisco access points and network
19 infrastructure.

20 45. On information and belief, Cisco used the information it obtained through its
21 relationship with InfoExpress to develop its own NAC technology products and to compete with
22 InfoExpress.

1 46. Cisco then used its size and market presence to sell its infringing version of its
2 NAC technology, including ISE, to drive revenue and additionally further its sales of its access
3 points, servers, software, and other products in its security infrastructure.

4 47. On information and belief, and at least given the InfoExpress-Cisco relationship,
5 Cisco was aware of InfoExpress’s pending Patent Portfolio and the Patents-in-Suit at the time of
6 such relationship and then following thereafter.

7 48. In addition, Cisco has knowledge of the Patent Portfolio including certain of the
8 Patents-in-Suit, and of its infringement thereof, because of Cisco’s own patent prosecution.

9 49. In Cisco’s prosecution of U.S. Published App. No. 2013/0290224, the United
10 States Patent and Trademark Office issued a February 3, 2015 Non-Final Rejection which
11 discusses InfoExpress’s U.S. Patent No. 8,347,351 and its disclosure of “document the full state
12 machine for port level authentication of one of a: personal computer or phone (citing Fig. 1,
13 elements 110 and 120, abstract, security policy [col. 2:56-3:33, 6:25-41]).”

14 50. Cisco’s May 1, 2015 Response to that Non-Final Rejection discusses and
15 characterizes InfoExpress’s ‘351 Patent.

16 51. In the prosecution of Cisco’s application no. 11/608,114, the Examiner’s May 14,
17 2009 rejection cited to InfoExpress’s published, pending application 2005/0063400 A1 (which,
18 at that time, had matured into the asserted ‘484 Patent).

19 52. Cisco’s patent prosecution at the U.S. Patent and Trademark Office meant that
20 Cisco had knowledge of at least the ‘484 and ‘351 patents. Given the prior relationship between
21 Cisco and InfoExpress, coupled with these rejections, Cisco must have tracked any continuations
22 of the cited InfoExpress patent applications, and thereby had additional knowledge of the
23 Patents-in-Suit upon issuance.

1 53. Accordingly, because of Cisco's knowledge of InfoExpress's Patent Portfolio,
2 including the Patents-in-Suit, coupled with Cisco's and InfoExpress's previous relationship, and
3 Cisco's knowledge obtained through prosecution of its own patent portfolio, Cisco knew of the
4 InfoExpress Patent Portfolio (including the Patents-In-Suit) and had knowledge of its
5 infringement, or at least was willfully blind to its infringement.

6 54. Cisco has been aware that it infringes the Patents-in-Suit since at least as of the
7 date of filing this Complaint, and at earliest of the first to issue patents. Since obtaining
8 knowledge of its infringing activities, Cisco has failed to cease its infringing activities.

9 55. Cisco has infringed, and continues to infringe, claims of the Patents-In-Suit in the
10 United States by making, using, offering for sale, selling and/or importing the Accused
11 Instrumentalities in violation of 35 U.S.C. § 271(a).

12 56. Cisco induces infringement by others of one or more claims of the Patents-in-Suit
13 in violation of 35 U.S.C. § 271(b) in aiding, instructing, promoting, encouraging or otherwise
14 acting with the intent to cause other parties, including customers, to use its Accused
15 Instrumentalities. Cisco is aware of the Patents-in-Suit, at least as of the filing and/or service of
16 this lawsuit, and knows or should have known that the inducing acts described herein constitutes
17 infringement of the Patents-in-Suit.

18 57. Cisco takes specific steps to actively induce others—for example, customers—to
19 use the Accused Instrumentalities and intentionally instructs infringing use at least by providing:

20 (1) brochures, installation and user guides, such as its *ISE Admin Guide*, which as
21 discussed above, instructs Cisco's customers to use ISE in infringing manner, as shown
22 below by way of example. The purpose of the Admin Guide and other literature is to
23 instruct Cisco's customers how to use ISE in an infringing manner:
24

1
2
3
4
5
6
7
8
9
10
11
12
13
14
15
16
17
18
19
20
21
22
23
24

Figure 30: Auth VLAN Connected to Cisco ISE Node

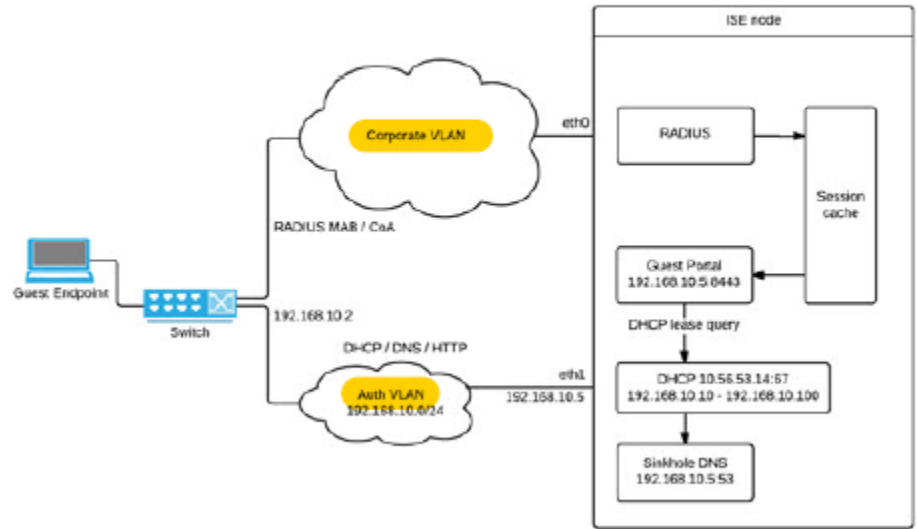

The following diagram displays a network with Auth VLAN and an IP helper.

Figure 31: Auth VLAN Configured with IP Helper

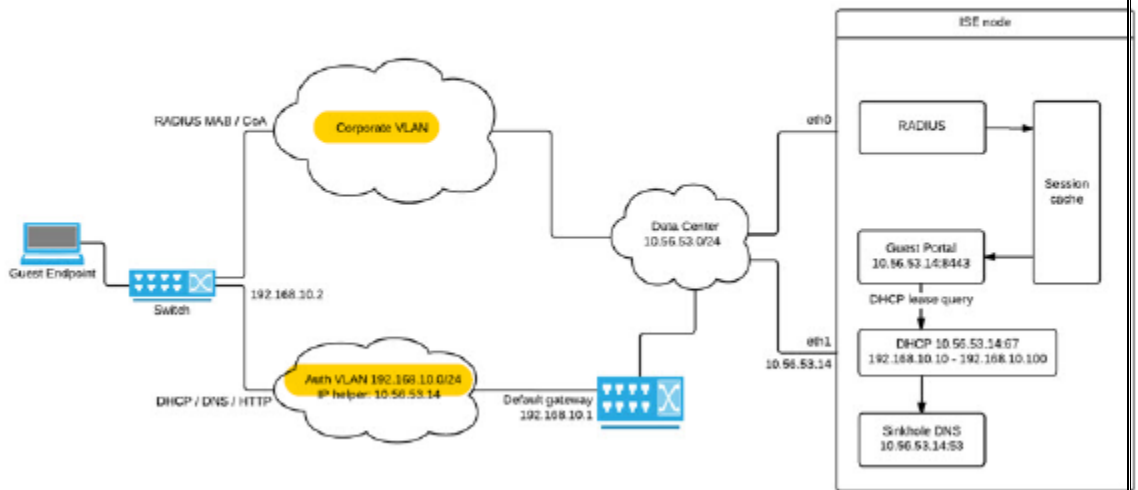
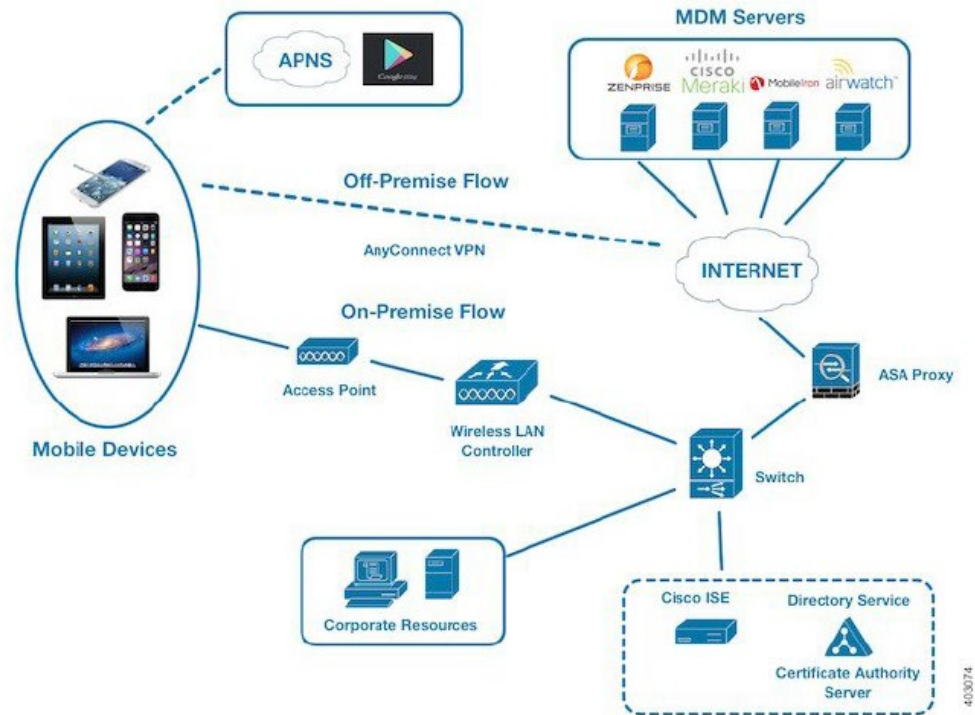

Figure 33: MDM Interoperability with Cisco ISE



ISE Admin Guide at pages 803-04 (Figures 30-31), 828 (Figure 32);

(2) webinars, training videos and demonstrations, for example, Cisco, *Secure Access with ISE*,

https://www.youtube.com/watch?v=rjv_1MNUbpM&list=PLvBZXH_IO6nCu9p49T11LE4kY6mpyz1eN&index=27, which (as specifically shown at 11:44 and 1:02:18), which, as shown in still images below, instructs third-party users to use the accused ISE instrumentality. The purpose of the this video and others is to instruct Cisco's customers how to use ISE in an infringing manner:

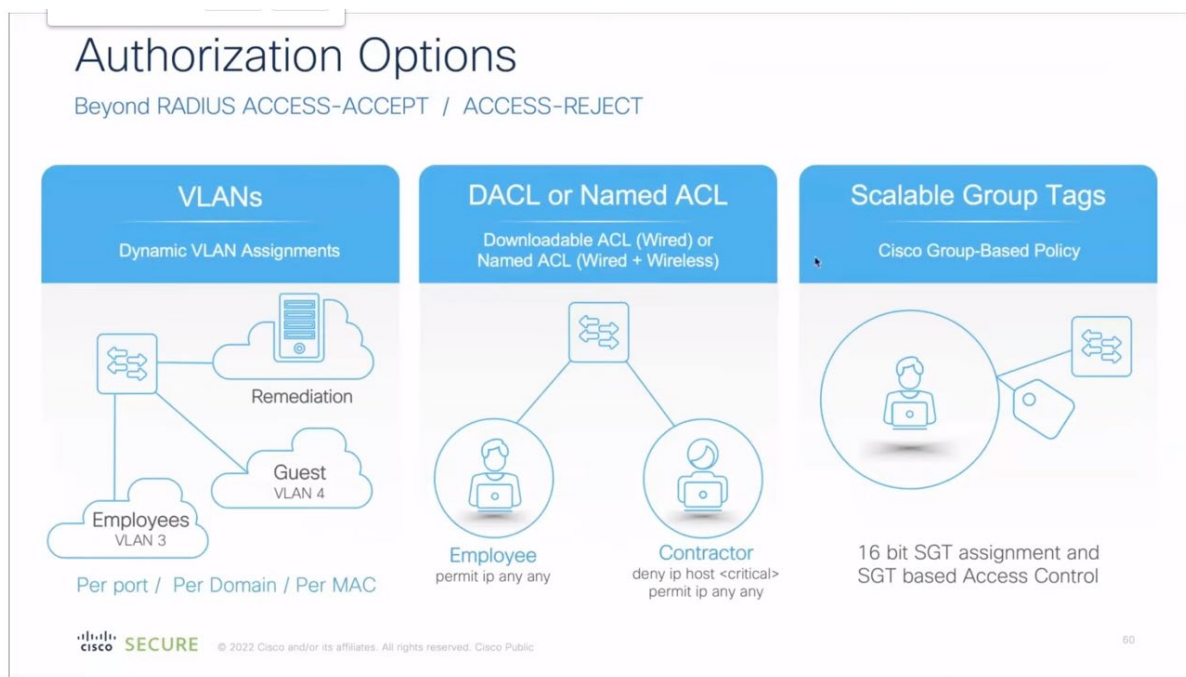
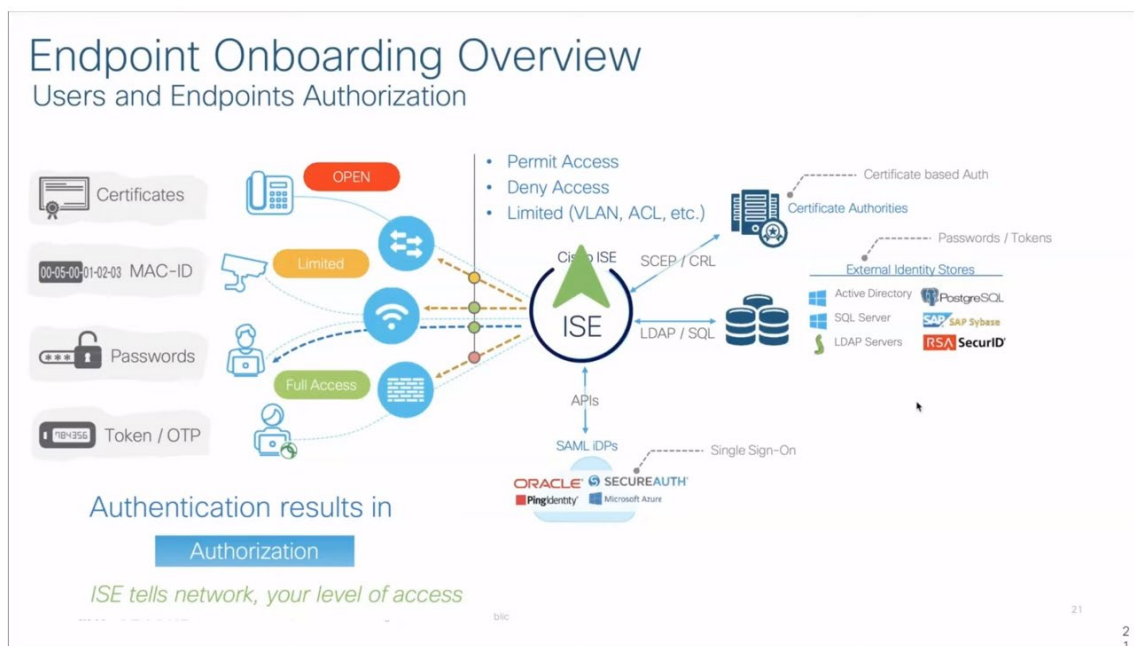

(3) software updates to its ISE through at least its website at

<https://software.cisco.com/download/home/283801620/type/283802505/release/3.1.0>,

whereby third party users are permitted to download certain portions of updated ISE

(such as software patches, etc.):

Software Download

Downloads Home / Security / Network Visibility and Segmentation / Identity Services Engine / Identity Services Engine Software / Identity Services Engine System Software- 3.1.0

Search...

Expand All Collapse All

Suggested Release

3.1.0

Latest Release

- HP-CSCwd45843
- HP-2.7P7-CSCwb29140
- 3.2.0
- log4j2-fix-3.1patch1

All Release

- Struts2-2018-11776
- Struts2-2017-5638
- Struts2-2016-1000031
- HP-CSCwd45843
- HP-CSCwb29140-2.7P7

Identity Services Engine Software

Release 3.1.0 Related Links and Documentation
[Release Notes for 3.1.0](#)

[My Notifications](#)

File Information	Release Date	Size	
Cisco Identity Services Engine Software Patch Version 3.1.0.518-Patch7-23052004 Apply this patch to an existing ISE 3.1.0 installation. ise-patchbundle-3.1.0.518-Patch7-23052004.SPA.x86_64.tar.gz Advisories	25-May-2023	3228.70 MB	↓ 🔍
Cisco Identity Services Engine Software Patch Version 3.1.0.518-Patch6-23032208 Apply this patch to an existing ISE 3.1.0 installation. ise-patchbundle-3.1.0.518-Patch6-23032208.SPA.x86_64.tar.gz Advisories	30-Mar-2023	3208.50 MB	↓ 🔍
Cisco ISE Software Version 3.1.0 full installation for SNS-37x5 appliances only. 3.1.0 patch 6 or greater must be applied after installation. May not be used to install 3.1.0 on SNS-36x5 appliances or virtualized ISE installs. ise-3.1.0.518c.SPA.x86_64_SNS-37x5_APPLIANCE_ONLY.iso Advisories	20-Mar-2023	11050.01 MB	↓ 🔍

(4) product support for ISE through its Cisco Support (*see, e.g.*, Cisco’s Technical Assistance Center (“TAC”)), whereby users can obtain technical support for their ISE products—for example, by gathering information such as error reports (either as a default feature on ISE, or at the specific request of Cisco personnel), and then upload that information to Cisco personnel for troubleshooting, as shown below:

Collect Support Bundle on Cisco ISE

Step 1. Enable Debugs for ISE Components

Various issues on ISE require different sets of logs to troubleshoot. A full list of needed debugs must be provided by the TAC engineer. However, ISE 3.x has preconfigured categories of debugs which you can use to collect initial logos to speed up case resolution.

The list of debugs requested by the TAC engineer must always take priority over this list.

In order to find these preconfigured debugs navigate to `Operations > Troubleshoot > Debug Wizard > Debug Profile Configuration`.

Choose the feature for which debugs must be enabled with the choice of the proper check box at the beginning of each row, for example, 802.1x (red), and navigate to node selection (green):

.....

1
2
3
4
5
6
7
8
9
10
11
12
13
14
15
16
17
18
19
20
21
22
23
24

When the process to create the Support Bundle is completed, it is available for download. After you click the `Download` button, the Support Bundle is saved on the local disk of the PC and can be uploaded to TAC in order to troubleshoot.

If the Web interface is not available, you can collect the Support Bundle from CLI. In order to do this, log in with the use of SSH or console access and use the command:

```
backup-logs name repository ftp {encryption-key plain key | public-key}
```

`name` - the name of your Support Bundle

`ftp` - the name of the repository configured on ISE

`key` - is the key used for encrypting/decrypting the Support Bundle

The official tool to upload the Support Bundle is <https://mycase.cloudapps.cisco.com/case>.

Do not zip or change the extension of the Support Bundle file. It must be `up`loaded in the same exact state as it was downloaded from ISE.

Cisco, *Collect Support Bundle on the Identity Services Engine*
<https://www.cisco.com/c/en/us/support/docs/security/identity-services-engine/214153-collect-support-bundle-on-cisco-identity.pdf> (last visited May 30, 2023).

(5) an online community for NAC and ISE support, hosted at

<https://community.cisco.com/t5/network-access-control/bd-p/discussions-network-access-control>, whereby users can pose technical questions about ISE, and others

(including Cisco personnel) can answer them, such as in the example below:

1
2
3
4
5
6
7
8
9
10
11
12
13
14
15
16
17
18
19
20
21
22
23
24

AWS and ISE and upgrades

[Go to solution](#)

 **charliey_2000** Beginner 03-08-2022 06:54 AM

I am trying to see if I could get some feedback about running ISE in AWS. Saw the known limitations in AWS but the line below was not clear to me. Does this mean you can not patch or upgrade the ISE in AWS? So you would have to stand up new servers and restore each time?

Cisco ISE upgrade workflow is not available in Cisco ISE on AWS. Only fresh installs are supported. However, you can carry out backup and restore of configuration data. When you restore the data in a Cisco ISE AWS instance, the data is upgraded to the Cisco ISE Release 3.1 version.

[I have this problem too](#)

Labels: [Identity Services Engine \(ISE\)](#)

[20 Helpful](#) [Share](#) [Reply](#)

1 Accepted Solution [All forum topics](#) [Previous Topic](#) [Next Topic](#)

 **Greg Gibbs** Cisco Employee 03-09-2022 02:18 PM

[View solution in original post](#)

The ISE upgrade workflow does not apply to patches; only upgrades to new major software versions (ISE 3.1 -> 3.2, for example). To perform these future upgrades for ISE in AWS, you will need to use the [Backup/Restore method described in the ISE 3.1 Upgrade Journey](#) rather than a direct upgrade.

Patches would be applied using the same method as on-prem ISE clusters.

[View solution in original post](#)

[10 Helpful](#) [Share](#) [Reply](#)

Cisco, *AWS and ISE and Upgrades* (March 8, 2022), <https://community.cisco.com/t5/network-access-control/aws-and-ise-and-upgrades/td-p/4566282> (last visited May 30, 2023).

58. Cisco’s activities cause users to use and infringe the systems and methods claimed in the Patents-In-Suit.

1
2
3
4
5
6
7
8
9
10
11
12
13
14
15
16
17
18
19
20
21
22
23
24

59. Cisco has also contributed to the infringement of one or more claims of the Patents-in-Suit, and continues to do so, by offering to commercially distribute, commercially distributing, or importing software and devices that constitute components of InfoExpress’s patented devices, and/or are configured to practice InfoExpress’s claimed methods.

60. For example, Cisco is liable for contributory infringement by making, using, selling, and offering to sell its servers, ISE hardware and software, and instructing users to infringe the claims of the Patents-in-Suit.

61. Cisco’s servers—including (at least) its Secure Network Servers (SNSs) 3615, 3655, and 3695 (“Cisco Servers”)—are material parts of InfoExpress’s claimed devices and systems, and are configured to practice InfoExpress’s claimed methods of NAC.

62. These Cisco Servers are “configured specifically to support the Cisco Identity Services Engine (ISE) security application.” These servers are not a staple article or commodity of commerce suitable for substantial noninfringing use.

The Cisco® Secure Network Server is based on the Cisco UCS® C220 Rack Server and is configured specifically to support the Cisco Identity Services Engine (ISE) security application. The Secure Network Server supports these applications in five versions. The Cisco Secure Network Server 3615 is designed for small deployments. The Secure Network Server 3655 and 3695 have several redundant components such as hard disks and power supplies, making it suitable for larger deployments that require highly reliable system configurations.

Figure 1 shows the Cisco Secure Network Server.



Figure 1.
Cisco SNS-3615, SNS-3655, and SNS-3695 Secure Network Server

Product specifications

Table 1 lists specifications of the Cisco Secure Network Server.

Table 1. Product specifications

Product Name	Secure Network Server 3615	Secure Network Server 3655	Secure Network Server 3655
Processor	1 - Intel Xeon 2.10 GHz 4110	1 - Intel Xeon 2.10 GHz 4116	1 - Intel Xeon 2.10 GHz 4116
Cores per processor	8	12	12
Memory	32 GB (2 x 16 GB)	96 GB (6 x 16 GB)	256 GB (8 x 32 GB)
Hard Disk	1 - 2.5-in. 600-GB 6Gb SAS 10K RPM	4 - 2.5-in. 600-GB 6Gb SAS 10K RPM	8 - 2.5-in. 600-GB 6Gb SAS 10K RPM

Cisco, Secure Network Servers Datasheet (2023), available at <https://www.cisco.com/c/en/us/products/collateral/security/identity-services-engine/datasheet-c78-726524.pdf> (last visited March 14, 2023).

63. Additionally, Cisco is liable for contributory infringement under 35 U.S.C. 271(c) because Cisco's software and devices reconfigure the communication port of an access point for communicating data between a user endpoint and protected resources on a protected network, once requirements of the security policy are satisfied. As such, Cisco's software and devices are especially made or especially adapted for use in an infringement, and are not a staple articles or commodities of commerce suitable for substantial noninfringing use. Cisco knows portions of the Accused Instrumentalities to be especially made or especially adapted for use in infringement of the Patents-in-Suit, not a staple article, and not a commodity of commerce suitable for substantially noninfringing use.

1 64. Cisco undertook and continues its infringing actions despite that it knew and/or
2 should have known that its actions constituted an unjustifiably high risk that its activities
3 infringed the Patents-in-Suit, which were duly issued by the USPTO, and are presumed valid.
4 Since first working with InfoExpress, and at the latest, the filing of this action, Cisco has been
5 aware of the unjustifiably high risk that its actions constituted and continue to constitute
6 infringement of the Patents-in-Suit, and that the Patents-in-Suit are valid. Cisco could not
7 reasonably, subjectively believe that its actions do not constitute infringement of the Patents-in-
8 Suit, and it could not reasonably, subjectively believe that the Patents-in-Suit are invalid.
9 Despite this knowledge and subjective belief, and the unjustifiably high risk that its actions
10 constitute infringement, Cisco has continued its infringing activities. As such, Cisco willfully
11 infringes the Patents-in-Suit.

12 **COUNT I: INFRINGEMENT OF THE '484 PATENT**

13 65. InfoExpress incorporates all previous paragraphs by reference as if fully stated
14 herein.

15 66. InfoExpress owns all substantial rights, interest, and title in and to the '484 Patent,
16 including the sole and exclusive right to prosecute this action and enforce the '484 Patent against
17 infringers, and to collect damages for all relevant times.

18 67. The '484 Patent describes in technical detail each of the limitations of the claims,
19 allowing a skilled artisan to understand the scope of the claims and how the non-conventional
20 and non-generic combination of claim limitations is patentably distinct from and improved upon
21 what may have been conventional or generic in the art at the time of the invention.

22 68. As set forth in the attached exemplary non-limiting Claim Chart (Exhibit G),
23 Cisco, without authorization or license from InfoExpress, has been and is presently directly
24 infringing, literally or under the doctrine of equivalents, at least one claim, including claim 41, of

1 the '484 Patent, pursuant to 35 U.S.C. § 271(a), including through making, using, selling,
2 offering to sell, and importing, in the United States the Accused Instrumentalities.

3 69. Cisco actively induces infringement under § 271(b) of at least one claim of the
4 '484 Patent by selling to its customers the Accused Instrumentalities with instructions as to how
5 to use the Accused Instrumentalities in a method such as recited in the '484 Patent. Cisco
6 knowingly aids, instructs, or otherwise acts with the specific intent to cause an end user to use
7 the Accused Instrumentalities. As noted above in paragraph 57, Cisco provides to third parties
8 (including its customers) (1) brochures and literature such as its ISE Admin Guide; (2) webinars,
9 training videos and demonstrations; (3) software updates to ISE; (4) product support for ISE; and
10 (5) an online community for NAC and ISE support, all of which instruct those third parties to
11 infringe the '484 patent. Additionally, Cisco knew of the '484 Patent and knew that its use and
12 sale of the Accused Instrumentalities infringe at least one claim of the '484 Patent, and Cisco is
13 thus liable for inducement of the '484 Patent pursuant to 35 U.S.C. § 271(b).

14 70. Cisco is liable for contributory infringement under § 271(c) of at least one claim
15 of the '484 Patent by providing, and by having knowingly provided the Accused
16 Instrumentalities, including the Cisco Servers and the ISE software and devices used to infringe
17 at least one claim of the '484 Patent. Cisco's ISE software, as sold, contains instructions for
18 performing the claimed methods of the '484 patent. Similarly, Cisco Servers are material parts
19 of InfoExpress's claimed inventions, and are configured to practice InfoExpress's claimed
20 methods of NAC. For example, Cisco's software and devices reconfigure the communication
21 port of an access point for communicating data between a user endpoint and protected resources
22 on a protected network, once requirements of the security policy are satisfied.

23 71. Cisco has known or should have known that its Cisco Servers and ISE software
24 and devices are especially made or especially adapted for use in infringement of the Patents-in-

1 Suit, not staple articles, and not commodities of commerce suitable for substantially
2 noninfringing use.

3 72. To the extent 35 U.S.C. § 287 is determined to be applicable, its requirements
4 have been satisfied with respect to the '484 Patent.

5 73. InfoExpress has been damaged as a result of the infringing conduct by Cisco
6 alleged above. Thus, Cisco is liable to InfoExpress in an amount that compensates it for such
7 infringement, which by law cannot be less than a reasonable royalty and in an amount yet to be
8 determined. InfoExpress is also entitled to receive such other and further relief, as this Court
9 deems just and proper.

10 74. InfoExpress alleges that Cisco's infringement of the '484 Patent has been and
11 continues to be deliberate and willful and egregious, and, therefore, this is an exceptional case
12 warranting an award of enhanced damages for up to three times the actual damages awarded and
13 attorney's fees to InfoExpress pursuant to 35 U.S.C. §§ 284-285. As noted above, Cisco has had
14 knowledge of the '484 Patent or at least was willfully blind to its infringement, as well as related
15 patents and patent applications, and its infringement thereof, and yet has deliberately continued
16 to infringe in a wanton, malicious, and egregious manner, with reckless disregard for
17 InfoExpress's patent rights. Thus, Cisco's infringing actions have been and continue to be
18 consciously wrongful.

19 75. Cisco's use of the '484 Patent is not licensed or authorized by InfoExpress in any
20 way.

21 **COUNT II: INFRINGEMENT OF THE '460 PATENT**

22 76. InfoExpress incorporates all previous paragraphs by reference as if fully stated
23 herein.

1 77. InfoExpress owns all substantial rights, interest, and title in and to the '460 Patent,
2 including the sole and exclusive right to prosecute this action and enforce the '460 Patent against
3 infringers, and to collect damages for all relevant times.

4 78. The '460 Patent describes in technical detail each of the limitations of the claims,
5 allowing a skilled artisan to understand the scope of the claims and how the non-conventional
6 and non-generic combination of claim limitations is patentably distinct from and improved upon
7 what may have been conventional or generic in the art at the time of the invention.

8 79. As set forth in the attached exemplary non-limiting Claim Chart (Exhibit H),
9 Cisco, without authorization or license from InfoExpress, has been and is presently directly
10 infringing, literally or under the doctrine of equivalents, at least one claim, including claim 16, of
11 the '460 Patent, pursuant to 35 U.S.C. § 271(a), including through making, using, selling,
12 offering to sell, and importing, in the United States the Accused Instrumentalities.

13 80. Cisco actively induces infringement under § 271(b) of at least one claim of the
14 '460 Patent by selling to its customers the Accused Instrumentalities with instructions as to how
15 to use the Accused Instrumentalities in a method such as recited in the '460 Patent. Cisco
16 knowingly aids, instructs, or otherwise acts with the specific intent to cause an end user to use
17 the Accused Instrumentalities. As noted above in paragraph 57, Cisco provides to third parties
18 (including its customers) (1) brochures and literature such as its ISE Admin Guide; (2) webinars,
19 training videos and demonstrations; (3) software updates to ISE; (4) product support for ISE; and
20 (5) an online community for NAC and ISE support, all of which instruct those third parties to
21 infringe the '460 patent. Additionally, Cisco knew of the '460 Patent and knew that its use and
22 sale of the Accused Instrumentalities infringe at least one claim of the '460 Patent, and Cisco is
23 thus liable for inducement of the '460 Patent pursuant to 35 U.S.C. § 271(b).

1 81. Cisco is liable for contributory infringement under § 271(c) of at least one claim
2 of the '460 Patent by providing, and by having knowingly provided the Accused
3 Instrumentalities, including the Cisco Servers and the ISE software and devices used to infringe
4 at least one claim of the '460 Patent. Cisco's ISE software, as sold, contains instructions for
5 performing the claimed methods of the '460 patent. Similarly, Cisco Servers are material parts
6 of InfoExpress's claimed inventions, and are configured to practice InfoExpress's claimed
7 methods of NAC. Additionally, Cisco's software and devices reconfigure the communication
8 port of an access point for communicating data between a user endpoint and protected resources
9 on a protected network, once requirements of the security policy are satisfied.

10 82. Cisco has known or should have known that its Cisco Servers and ISE software
11 and devices are especially made or especially adapted for use in infringement of the Patents-in-
12 Suit, not staple articles, and not commodities of commerce suitable for substantially
13 noninfringing use.

14 83. To the extent 35 U.S.C. § 287 is determined to be applicable, its requirements
15 have been satisfied with respect to the '460 Patent.

16 84. InfoExpress has been damaged as a result of the infringing conduct by Cisco
17 alleged above. Thus, Cisco is liable to InfoExpress in an amount that compensates it for such
18 infringement, which by law cannot be less than a reasonable royalty and in an amount yet to be
19 determined. InfoExpress is also entitled to receive such other and further relief, as this Court
20 deems just and proper.

21 85. InfoExpress alleges that Cisco's infringement of the '460 Patent has been and
22 continues to be deliberate and willful and egregious, and, therefore, this is an exceptional case
23 warranting an award of enhanced damages for up to three times the actual damages awarded and
24 attorney's fees to InfoExpress pursuant to 35 U.S.C. §§ 284-285. As noted above, Cisco has had

1 knowledge of the '460 Patent or at least was willfully blind to its infringement, as well as related
2 patents and patent applications, and its infringement thereof, and yet has deliberately continued
3 to infringe in a wanton, malicious, and egregious manner, with reckless disregard for
4 InfoExpress's patent rights. Thus, Cisco's infringing actions have been and continue to be
5 consciously wrongful.

6 86. Cisco's use of the '460 Patent is not licensed or authorized by InfoExpress in any
7 way.

8 **COUNT III: INFRINGEMENT OF THE '450 PATENT**

9 87. InfoExpress incorporates all previous paragraphs by reference as if fully stated
10 herein.

11 88. InfoExpress owns all substantial rights, interest, and title in and to the '450 Patent,
12 including the sole and exclusive right to prosecute this action and enforce the '450 Patent against
13 infringers, and to collect damages for all relevant times.

14 89. The '450 Patent describes in technical detail each of the limitations of the claims,
15 allowing a skilled artisan to understand the scope of the claims and how the non-conventional
16 and non-generic combination of claim limitations is patentably distinct from and improved upon
17 what may have been conventional or generic in the art at the time of the invention.

18 90. As set forth in the attached exemplary non-limiting Claim Chart (Exhibit I),
19 Cisco, without authorization or license from InfoExpress, has been and is presently directly
20 infringing, literally or under the doctrine of equivalents, at least one claim, including claim 1, of
21 the '450 Patent, pursuant to 35 U.S.C. § 271(a), including through making, using, selling,
22 offering to sell, and importing, in the United States the Accused Instrumentalities.

23 91. Cisco actively induces infringement under § 271(b) of at least one claim of the
24 '450 Patent by selling to its customers the Accused Instrumentalities with instructions as to how

1 to use the Accused Instrumentalities in a method such as recited in the '450 Patent. Cisco
2 knowingly aids, instructs, or otherwise acts with the specific intent to cause an end user to use
3 the Accused Instrumentalities. As noted above in paragraph 57, Cisco provides to third parties
4 (including its customers) (1) brochures and literature such as its ISE Admin Guide; (2) webinars,
5 training videos and demonstrations; (3) software updates to ISE; (4) product support for ISE; and
6 (5) an online community for NAC and ISE support, all of which instruct those third parties to
7 infringe the '450 patent. Additionally, Cisco knew of the '450 Patent and knew that its use and
8 sale of the Accused Instrumentalities infringe at least one claim of the '450 Patent, and Cisco is
9 thus liable for inducement of the '450 Patent pursuant to 35 U.S.C. § 271(b).

10 92. Cisco is liable for contributory infringement under § 271(c) of at least one claim
11 of the '450 Patent by providing, and by having knowingly provided the Accused
12 Instrumentalities, including the Cisco Servers and the ISE software and devices used to infringe
13 at least one claim of the '450 Patent. Cisco's ISE software, as sold, contains instructions for
14 performing the claimed methods of the '450 patent. Similarly, Cisco Servers are material parts
15 of InfoExpress's claimed inventions, and are configured to practice InfoExpress's claimed
16 methods of NAC. Additionally, Cisco's software and devices scan a network device connected
17 to an access point to collect information regarding that device, apply a security policy that relates
18 to such information, and configure the access point in response to a result of applying the
19 security policy.

20 93. Cisco has known or should have known that its Cisco Servers and ISE software
21 and devices are especially made or especially adapted for use in infringement of the Patents-in-
22 Suit, not staple articles, and not commodities of commerce suitable for substantially
23 noninfringing use.

1 94. To the extent 35 U.S.C. § 287 is determined to be applicable, its requirements
2 have been satisfied with respect to the '450 Patent.

3 95. InfoExpress has been damaged as a result of the infringing conduct by Cisco
4 alleged above. Thus, Cisco is liable to InfoExpress in an amount that compensates it for such
5 infringement, which by law cannot be less than a reasonable royalty and in an amount yet to be
6 determined. InfoExpress is also entitled to receive such other and further relief, as this Court
7 deems just and proper.

8 96. InfoExpress alleges that Cisco's infringement of the '450 Patent has been and
9 continues to be deliberate and willful and egregious, and, therefore, this is an exceptional case
10 warranting an award of enhanced damages for up to three times the actual damages awarded and
11 attorney's fees to InfoExpress pursuant to 35 U.S.C. §§ 284-285. As noted above, Cisco has had
12 knowledge of the '450 Patent or at least was willfully blind to its infringement, as well as related
13 patents and patent applications, and its infringement thereof, and yet has deliberately continued
14 to infringe in a wanton, malicious, and egregious manner, with reckless disregard for
15 InfoExpress's patent rights. Thus, Cisco's infringing actions have been and continue to be
16 consciously wrongful.

17 97. Cisco's use of the '450 Patent is not licensed or authorized by InfoExpress in any
18 way.

19 **COUNT IV: INFRINGEMENT OF THE '444 PATENT**

20 98. InfoExpress incorporates all previous paragraphs by reference as if fully stated
21 herein.

22 99. InfoExpress owns all substantial rights, interest, and title in and to the '444 Patent,
23 including the sole and exclusive right to prosecute this action and enforce the '444 Patent against
24 infringers, and to collect damages for all relevant times.

1 100. The '444 Patent describes in technical detail each of the limitations of the claims,
2 allowing a skilled artisan to understand the scope of the claims and how the non-conventional
3 and non-generic combination of claim limitations is patentably distinct from and improved upon
4 what may have been conventional or generic in the art at the time of the invention.

5 101. As set forth in the attached exemplary non-limiting Claim Chart (Exhibit J),
6 Cisco, without authorization or license from InfoExpress, has been and is presently directly
7 infringing, literally or under the doctrine of equivalents, at least one claim, including claim 1, of
8 the '444 Patent, pursuant to 35 U.S.C. § 271(a), including through making, using, selling,
9 offering to sell, and importing, in the United States the Accused Instrumentalities.

10 102. Cisco actively induces infringement under § 271(b) of at least one claim of the
11 '444 Patent by selling to its customers the Accused Instrumentalities with instructions as to how
12 to use the Accused Instrumentalities in a method such as recited in the '444 Patent. Cisco
13 knowingly aids, instructs, or otherwise acts with the specific intent to cause an end user to use
14 the Accused Instrumentalities. As noted above in paragraph 57, Cisco provides to third parties
15 (including its customers) (1) brochures and literature such as its ISE Admin Guide; (2) webinars,
16 training videos and demonstrations; (3) software updates to ISE; (4) product support for ISE; and
17 (5) an online community for NAC and ISE support, all of which instruct those third parties to
18 infringe the '444 patent. Additionally, Cisco knew of the '444 Patent and knew that its use and
19 sale of the Accused Instrumentalities infringe at least one claim of the '444 Patent, and Cisco is
20 thus liable for inducement of the '444 Patent pursuant to 35 U.S.C. § 271(b).

21 103. Cisco is liable for contributory infringement under § 271(c) of at least one claim
22 of the '444 Patent by providing, and by having knowingly provided the Accused
23 Instrumentalities, including the Cisco Servers and the ISE software and devices used to infringe
24 at least one claim of the '444 Patent. Cisco's ISE software, as sold, contains instructions for

1 performing the claimed methods of the '444 patent. Similarly, Cisco Servers are material parts
2 of InfoExpress's claimed inventions, and are configured to practice InfoExpress's claimed
3 methods of NAC. Additionally, Cisco's software and devices authenticate using an EAP
4 protocol, send a request for audit data to an agent running on a device, receive audit data from
5 that device in response to that request, and apply a security policy relating to the audit data and
6 the authentication.

7 104. Cisco has known or should have known that its Cisco Servers and ISE software
8 and devices are especially made or especially adapted for use in infringement of the Patents-in-
9 Suit, not staple articles, and not commodities of commerce suitable for substantially
10 noninfringing use.

11 105. To the extent 35 U.S.C. § 287 is determined to be applicable, its requirements
12 have been satisfied with respect to the '444 Patent.

13 106. InfoExpress has been damaged as a result of the infringing conduct by Cisco
14 alleged above. Thus, Cisco is liable to InfoExpress in an amount that compensates it for such
15 infringement, which by law cannot be less than a reasonable royalty and in an amount yet to be
16 determined. InfoExpress is also entitled to receive such other and further relief, as this Court
17 deems just and proper.

18 107. InfoExpress alleges that Cisco's infringement of the '444 Patent has been and
19 continues to be deliberate and willful and egregious, and, therefore, this is an exceptional case
20 warranting an award of enhanced damages for up to three times the actual damages awarded and
21 attorney's fees to InfoExpress pursuant to 35 U.S.C. §§ 284-285. As noted above, Cisco has had
22 knowledge of the '444 Patent or at least was willfully blind to its infringement, as well as related
23 patents and patent applications, and its infringement thereof, and yet has deliberately continued
24 to infringe in a wanton, malicious, and egregious manner, with reckless disregard for

1 InfoExpress's patent rights. Thus, Cisco's infringing actions have been and continue to be
2 consciously wrongful.

3 108. Cisco's use of the '444 Patent is not licensed or authorized by InfoExpress in any
4 way.

5 **COUNT V: INFRINGEMENT OF THE '350 PATENT**

6 109. InfoExpress incorporates all previous paragraphs by reference as if fully stated
7 herein.

8 110. InfoExpress owns all substantial rights, interest, and title in and to the '350 Patent,
9 including the sole and exclusive right to prosecute this action and enforce the '350 Patent against
10 infringers, and to collect damages for all relevant times.

11 111. The '350 Patent describes in technical detail each of the limitations of the claims,
12 allowing a skilled artisan to understand the scope of the claims and how the non-conventional
13 and non-generic combination of claim limitations is patentably distinct from and improved upon
14 what may have been conventional or generic in the art at the time of the invention.

15 112. As set forth in the attached exemplary non-limiting Claim Chart (Exhibit K),
16 Cisco, without authorization or license from InfoExpress, has been and is presently directly
17 infringing, literally or under the doctrine of equivalents, at least one claim, including claim 1, of
18 the '350 Patent, pursuant to 35 U.S.C. § 271(a), including through making, using, selling,
19 offering to sell, and importing, in the United States the Accused Instrumentalities.

20 113. Cisco actively induces infringement under § 271(b) of at least one claim of the
21 '350 Patent by selling to its customers the Accused Instrumentalities with instructions as to how
22 to use the Accused Instrumentalities in a method such as recited in the '350 Patent. Cisco
23 knowingly aids, instructs, or otherwise acts with the specific intent to cause an end user to use
24 the Accused Instrumentalities. As noted above in paragraph 57, Cisco provides to third parties

1 (including its customers) (1) brochures and literature such as its ISE Admin Guide; (2) webinars,
2 training videos and demonstrations; (3) software updates to ISE; (4) product support for ISE; and
3 (5) an online community for NAC and ISE support, all of which instruct those third parties to
4 infringe the '350 patent. Additionally, Cisco knew of the '350 Patent and knew that its use and
5 sale of the Accused Instrumentalities infringe at least one claim of the '350 Patent, and Cisco is
6 thus liable for inducement of the '350 Patent pursuant to 35 U.S.C. § 271(b).

7 114. Cisco is liable for contributory infringement under § 271(c) of at least one claim
8 of the '350 Patent by providing, and by having knowingly provided the Accused
9 Instrumentalities, including the Cisco Servers and the ISE software and devices used to infringe
10 at least one claim of the '350 Patent. Cisco's ISE software, as sold, contains instructions for
11 performing the claimed methods of the '350 patent. Similarly, Cisco Servers are material parts
12 of InfoExpress's claimed inventions, and are configured to practice InfoExpress's claimed
13 methods of NAC. Additionally, Cisco's software and devices receive audit data pertaining to a
14 device that does not have access to a less-restricted subset of a network, audit the device in
15 accordance with a security policy based at least in part on the audit data, reconfigure an access
16 point to allow access to the less-restricted subset of the network in response to the security policy
17 audit, and continually receive and evaluate updated audit data.

18 115. Cisco has known or should have known that its Cisco Servers and ISE software
19 and devices are especially made or especially adapted for use in infringement of the Patents-in-
20 Suit, not staple articles, and not commodities of commerce suitable for substantially
21 noninfringing use.

22 116. To the extent 35 U.S.C. § 287 is determined to be applicable, its requirements
23 have been satisfied with respect to the '350 Patent.
24

1 117. InfoExpress has been damaged as a result of the infringing conduct by Cisco
2 alleged above. Thus, Cisco is liable to InfoExpress in an amount that compensates it for such
3 infringement, which by law cannot be less than a reasonable royalty and in an amount yet to be
4 determined. InfoExpress is also entitled to receive such other and further relief, as this Court
5 deems just and proper.

6 118. InfoExpress alleges that Cisco's infringement of the '350 Patent has been and
7 continues to be deliberate and willful and egregious, and, therefore, this is an exceptional case
8 warranting an award of enhanced damages for up to three times the actual damages awarded and
9 attorney's fees to InfoExpress pursuant to 35 U.S.C. §§ 284-285. As noted above, Cisco has had
10 knowledge of the '350 Patent or at least was willfully blind to its infringement, as well as related
11 patents and patent applications, and its infringement thereof, and yet has deliberately continued
12 to infringe in a wanton, malicious, and egregious manner, with reckless disregard for
13 InfoExpress's patent rights. Thus, Cisco's infringing actions have been and continue to be
14 consciously wrongful.

15 119. Cisco's use of the '350 Patent is not licensed or authorized by InfoExpress in any
16 way.

17 **COUNT VI: INFRINGEMENT OF THE '645 PATENT**

18 120. InfoExpress incorporates all previous paragraphs by reference as if fully stated
19 herein.

20 121. InfoExpress owns all substantial rights, interest, and title in and to the '645 Patent,
21 including the sole and exclusive right to prosecute this action and enforce the '645 Patent against
22 infringers, and to collect damages for all relevant times.

23 122. The '645 Patent describes in technical detail each of the limitations of the claims,
24 allowing a skilled artisan to understand the scope of the claims and how the non-conventional

1 and non-generic combination of claim limitations is patentably distinct from and improved upon
2 what may have been conventional or generic in the art at the time of the invention.

3 123. As set forth in the attached exemplary non-limiting Claim Chart (Exhibit L),
4 Cisco, without authorization or license from InfoExpress, has been and is presently directly
5 infringing, literally or under the doctrine of equivalents, at least one claim, including claim 1, of
6 the '645 Patent, pursuant to 35 U.S.C. § 271(a), including through making, using, selling,
7 offering to sell, and importing, in the United States the Accused Instrumentalities.

8 124. Cisco actively induces infringement under § 271(b) of at least one claim of the
9 '645 Patent by selling to its customers the Accused Instrumentalities with instructions as to how
10 to use the Accused Instrumentalities in a method such as recited in the '645 Patent. Cisco
11 knowingly aids, instructs, or otherwise acts with the specific intent to cause an end user to use
12 the Accused Instrumentalities. As noted above in paragraph 57, Cisco provides to third parties
13 (including its customers) (1) brochures and literature such as its ISE Admin Guide; (2) webinars,
14 training videos and demonstrations; (3) software updates to ISE; (4) product support for ISE; and
15 (5) an online community for NAC and ISE support, all of which instruct those third parties to
16 infringe the '645 patent. Additionally, Cisco knew of the '645 Patent and knew that its use and
17 sale of the Accused Instrumentalities infringe at least one claim of the '645 Patent, and Cisco is
18 thus liable for inducement of the '645 Patent pursuant to 35 U.S.C. § 271(b).

19 125. Cisco is liable for contributory infringement under § 271(c) of at least one claim
20 of the '645 Patent by providing, and by having knowingly provided the Accused
21 Instrumentalities, including the Cisco Servers and the ISE software and devices used to infringe
22 at least one claim of the '645 Patent. Cisco's ISE software, as sold, contains instructions for
23 performing the claimed methods of the '645 patent. Similarly, Cisco Servers are material parts
24 of InfoExpress's claimed inventions, and are configured to practice InfoExpress's claimed

1 methods of NAC. Additionally, Cisco's software and devices formulate and send audit requests
2 to user devices (i.e. endpoints), receive information in response to those audit requests, evaluate
3 that information, receive authentication information from the device using an extensible
4 authentication protocol (EAP), and configure an access point in response to approval of the
5 device by a gatekeeper.

6 126. Cisco has known or should have known that its Cisco Servers and ISE software
7 and devices are especially made or especially adapted for use in infringement of the Patents-in-
8 Suit, not staple articles, and not commodities of commerce suitable for substantially
9 noninfringing use.

10 127. To the extent 35 U.S.C. § 287 is determined to be applicable, its requirements
11 have been satisfied with respect to the '645 Patent.

12 128. InfoExpress has been damaged as a result of the infringing conduct by Cisco
13 alleged above. Thus, Cisco is liable to InfoExpress in an amount that compensates it for such
14 infringement, which by law cannot be less than a reasonable royalty and in an amount yet to be
15 determined. InfoExpress is also entitled to receive such other and further relief, as this Court
16 deems just and proper.

17 129. InfoExpress alleges that Cisco's infringement of the '645 Patent has been and
18 continues to be deliberate and willful and egregious, and, therefore, this is an exceptional case
19 warranting an award of enhanced damages for up to three times the actual damages awarded and
20 attorney's fees to InfoExpress pursuant to 35 U.S.C. §§ 284-285. As noted above, Cisco has had
21 knowledge of the '645 Patent or at least was willfully blind to its infringement, as well as related
22 patents and patent applications, and its infringement thereof, and yet has deliberately continued
23 to infringe in a wanton, malicious, and egregious manner, with reckless disregard for
24

1 InfoExpress's patent rights. Thus, Cisco's infringing actions have been and continue to be
2 consciously wrongful.

3 130. Cisco's use of the '645 Patent is not licensed or authorized by InfoExpress in any
4 way.

5 **VI. DEMAND FOR JURY TRIAL**

6 Pursuant to Federal Rule of Civil Procedure 38(b), InfoExpress hereby demands a trial by
7 jury of any and all issues triable of right before a jury.

8 **VII. PRAYER FOR RELIEF**

9 **WHEREFORE**, InfoExpress respectfully requests that the Court:

10 A. Enter a judgment that Cisco has infringed one or more claims of the Patents-in-
11 Suit;

12 B. Enter a preliminary and permanent injunction against Cisco and its officers,
13 employees, agents, servants, attorneys, instrumentalities, and/or those in privity with them from
14 infringing the Patents-in-Suit and for all further and proper injunctive relief pursuant to 35
15 U.S.C. § 283.

16 C. Enter a judgment awarding Plaintiff InfoExpress of such damages adequate to
17 compensate it for Cisco's infringement of the Patents-in-Suit, including lost profits but no less
18 than a reasonable royalty, as well as pre-judgment and post-judgment interest at the maximum
19 rate permitted by law,;

20 D. Declare that the Patents-in-Suit are valid and enforceable;

21 E. Order Cisco to pay damages adequate to compensate InfoExpress for Cisco's
22 infringement, together with interest and costs under 35 U.S.C. § 284;

23 F. Order Cisco to pay supplemental damages to InfoExpress, including interest, with
24 an accounting, as needed;

1 G. Declare this case exceptional pursuant to 35 U.S.C. § 285;

2 H. Declare that Cisco's infringement is willful, wanton, deliberate, and egregious
3 and that the damages awarded to InfoExpress should be enhanced up to three times the actual
4 damages awarded;

5 I. Award Plaintiff InfoExpress its costs, disbursements, expert witness fees, and
6 attorneys' fees incurred in prosecution this action, with interest; and

7 J. Award Plaintiff InfoExpress other such and further relief, including equitable
8 relief, as this Court deems just and proper.

9
10
11
12
13
14
15
16
17
18
19
20
21
22
23
24

1 Dated: May 31, 2023

Respectfully submitted,

2
3 /s/ Brian R. Michalek, Esq.

Brian R. Michalek (SBN 302007) (*pro hac vice*)
brian.michalek@saul.com

4 Casey T. Grabenstein (*pro hac vice* forthcoming)
casey.grabenstein@saul.com

5 Joseph M. Kuo (*pro hac vice* forthcoming)
joseph.kuo@saul.com

6 SAUL EWING LLP
161 N. Clark St., Suite 4200
7 Chicago, IL 60601
Telephone: (312) 876-7100
8 Facsimile: (312) 876-0288

9 Andrew Schwerin (*pro hac vice* forthcoming)
andrew.schwerin@saul.com

10 Centre Square West
1500 Market Street, 38th Floor
11 Philadelphia, PA 19102 2186
Telephone: (215) 972-7184
12 Facsimile: (215) 972-7184

13 Michael E. Flynn-O'Brien (SBN 291301)

14 Elizabeth Day (SBN 177125)

BUNSOW DE MORY LLP
701 El Camino Real

15 Redwood City, CA 94063
Telephone: (650) 351-7245
16 Facsimile: (415) 426-4744
mflynnobrien@bdiplaw.com

17 *Attorneys for Plaintiff InfoExpress Inc.*