

**IN THE UNITED STATES DISTRICT COURT
FOR THE WESTERN DISTRICT OF TEXAS
WACO DIVISION**

NIMITZ TECHNOLOGIES LLC, Plaintiff v. CLAYTON HOMES, INC., Defendant.	Case No. 6:22-cv-01239 Jury Trial Demanded
--	---

COMPLAINT FOR PATENT INFRINGEMENT

Plaintiff Nimitz Technologies LLC, by and through the undersigned counsel, files this Complaint for patent infringement against Defendant Clayton Homes, Inc., and in support states, all upon information and belief:

PARTIES

1. Plaintiff Nimitz Technologies LLC is a limited liability company organized and existing under the laws of the State of Texas and having its office address at 3333 Preston Road STE 300, #1047, Frisco, TX 75034 (“Nimitz” or “Plaintiff”).

2. Defendant Clayton Homes, Inc. is an entity existing under the laws of the State of Delaware, with a registered office located at Wilmington Trust SP Services, Inc., 1100 N. Market Street 4th Floor, Wilmington, DE 19890. (“Clayton” or “Defendant”). Clayton is a wholly owned subsidiary of Berkshire Hathaway Inc., a Delaware corporation.

JURISDICTION AND VENUE

3. This is an action for patent infringement arising under the patent laws of the United States, 35 U.S.C. § 1 *et seq.*, including 35 U.S.C. §§ 271. This Court has subject matter jurisdiction under 28 U.S.C. §§ 1331 and 1338(a).

4. This Court has personal jurisdiction over Defendant at least because Defendant is doing business in, and is organized under the laws of, the State of Texas.

5. Venue is proper in this Judicial District under 28 U.S.C. §§ 1391 and 1400(b) because Defendant has committed acts of infringement and has a regular and established place of business in this District including the following locations: Clayton Homes of Austin, 6801 E. Ben White Blvd., Austin, TX 78741; Oakwood Homes of Austin, 6925 E. Ben White Blvd., Austin, TX 78741; and Clayton Homes of Waco, 4903 N I-35 Waco, TX 76705.

PATENT 7,848,328

6. U.S. Patent No. 7,848,328, entitled “Broadcast Content Encapsulation” (the “’328 Patent”) was duly and legally issued on December 7, 2010. A true and correct copy of the ’328 Patent is attached as Exhibit 1.

7. Plaintiff is the named assignee of, owns all right, title and interest in, and has standing to sue and recover all past damages for infringement of the ’328 Patent.

8. Claim 1 of the ’328 Patent is directed to a specific implementation of a highly technical method for delivering to consumers multiple versions of a specific content.

9. The claimed method begins with “components.” Upon receiving the audio and/or visual elements of a specific content, the provider processes and compresses the information into a series of files that are packaged into a series of “components” which are specific containers

storing the resulting video/audio files. The Patent illustrates one embodiment of “components” in Figure 2:

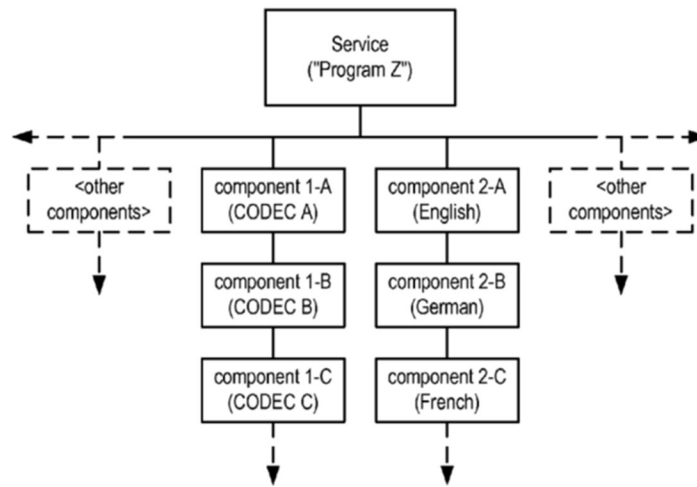

FIG. 2

10. The “components” are versatile and the provider may design “components” in a form that is most suitable for the needs of the particular provider. For example, the Patent teaches that the “components” may be specific to one or more of bit rates to accommodate a hierarchical content coding scheme, language, specific protocols and codecs, resolutions, subtitles, rich media, graphics and separate video and audio components as possible available

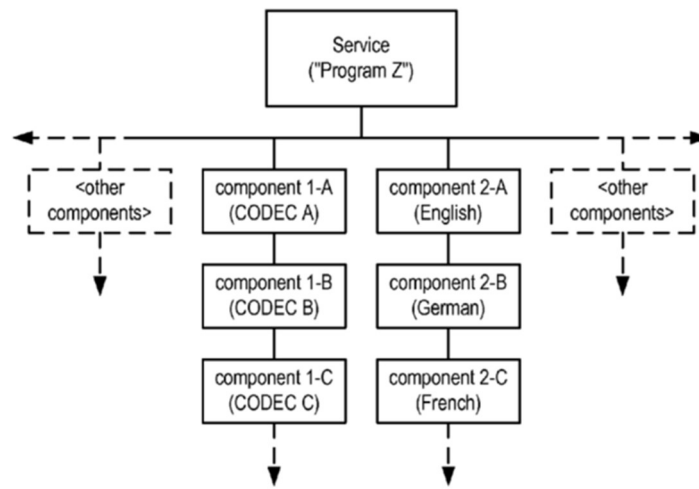

FIG. 2

“component” structures. (‘328 Patent at 3:13-45).

11. Claim 1 then requires the specific content to be delivered in different versions via multiple data streams with each stream corresponding to a “component.” The claims refer to this as the “mapping” of the data streams to the “components,” and this is depicted in Figure 4:

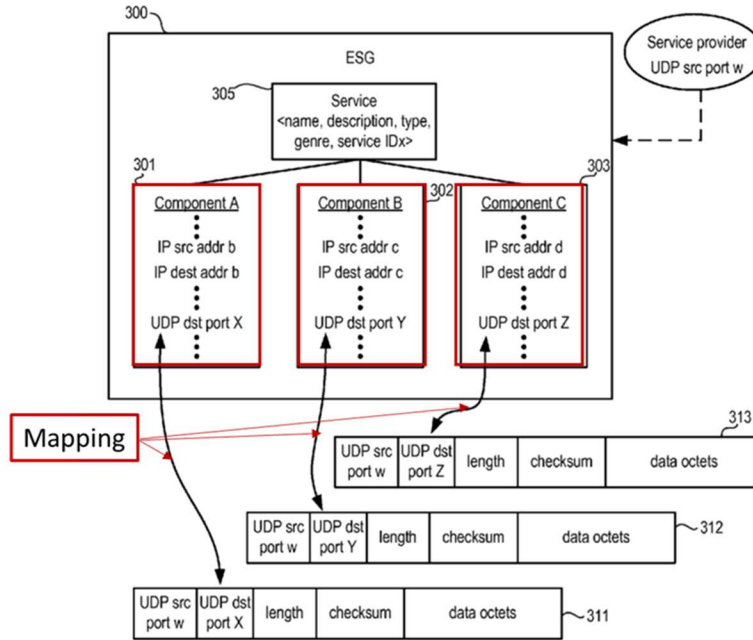

FIG. 4

12. Claim 1 next requires “encapsulating each data stream of the plurality into a stream of packets according to a first communication protocol” and that “as to each of the packet streams, the packets have a value in a common field identifying the component mapped to the data stream encapsulated by the packet stream.” This limitation is again illustrated in Figure 4 as follows:

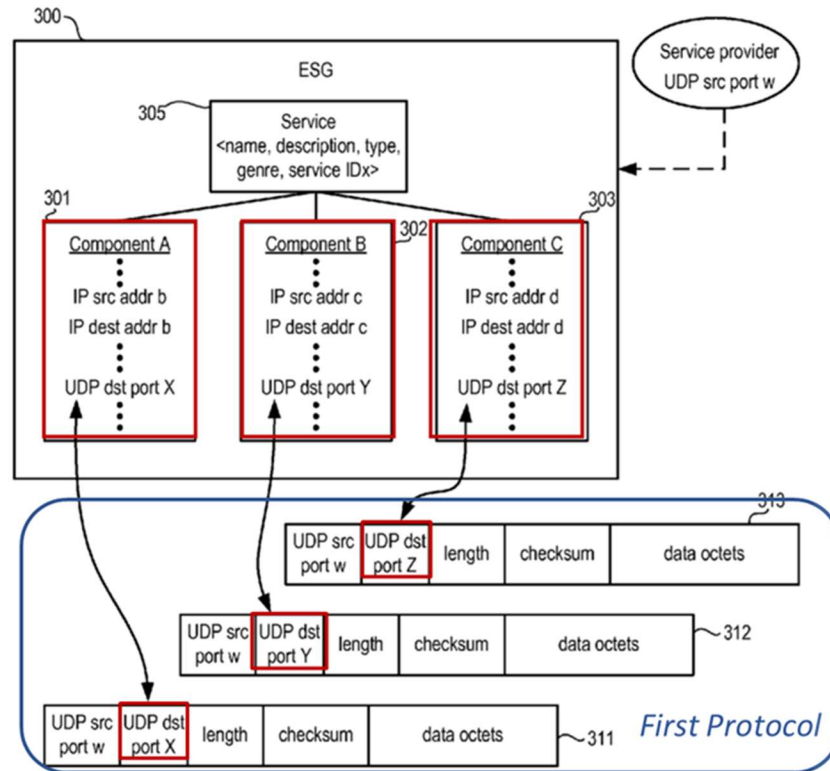

FIG. 4

13. Claim 1 also requires that “the mapping further comprises assigning a specific value to each component for a predefined field of a packet according to a second communication protocol, the specific value distinguishing the component from other components, and the encapsulating comprises encapsulating the packet streams according to one or more lower layer protocols without encapsulating the packet streams according to the second communication protocol.” This particular step of the claimed method requires that a streaming provider deliver packet streams to consumers who require a different second protocol without encapsulating the data streams in that particular second protocol by assigning a specific value in a predefined field of a packet to “components” directed to the second communication protocol where the specific value distinguishing the component from other components and encapsulating the packet streams according to one or more lower layer protocols.

14. Finally, claim 1 requires “forwarding the packet streams for transmission in a transmission channel,” which is the delivery of content to the consumer.

15. The above claim limitations for delivering content to consumers are not abstract, but concrete and definitive steps in organizing “components” and “data streams,” and populating frames in the data stream, in language that is so specific as to resemble instructions in a user manual.

16. The United States Patent and Trademark Office specifically identified in the Notice of Allowance the limitations that were entirely missing in the prior art:

assigning a specific value to each component for a predefined field of a packet according to a second communication protocol, the specific value distinguishing the component from other components, and the encapsulating comprises encapsulating the packet streams according to one or more lower layer protocols without encapsulating the packet streams according to the second communication protocol..

(Notice of Allowability).

17. All the claims differed from the closest prior art, Arad et al. US Pat. 7,590,991, Balakrishnan et al. US Pat. 7,227,899, Poli et al. US Pat Appln. 2005/0122976, Anschutz et al. US Pat. Appln. 2004/0230695 and Rakib, Selim Shlomo US Pat. 6,970, 127, all of which disclosed conventional communication systems, either singularly or in combination, and, thus, failed to anticipate or render the above features obvious. (Notice of Allowability).

18. The method claims are patent eligible under 35 U.S.C. § 101. The claims are not abstract. As reflected in the Notice of Allowance, the claims are directed to a novel improvement that, unlike conventional art, comprises assigning a specific value to each component for a predefined field of a packet according to a second communication protocol, with the specific value distinguishing the component from other components, and the encapsulating comprises encapsulating the packet streams according to one or more lower layer

protocols without encapsulating the packet streams according to the second communication protocol.

19. Thus, the '328 Patent claims focus on specific improvements in computer capabilities as opposed to an invention that simply uses computers as a tool. The focus of the claimed advance is on a solution to a technological problem arising in computer operations and provides a specific improvement in computer capabilities or functionality, rather than only claiming a desirable result or function.

20. Further, Claim 1 and its dependent claims, individually and as an ordered combination, recite an inventive concept, which is manifestly more than the application of an abstract idea using well-understood, routine, and conventional activities previously known to the industry. As stated by the Examiner, prior to the present invention, there was no prior art disclosing a system and method for encapsulating data streams, and particularly where the data streams related to a specific content that is mapped to components of a transmission service that delivers multiple versions of that specific content. Such content may include audio data, video data and/or other types of data, some or all of which may be any combination of real-time and non-real-time data. For example, versions of the content may vary based on a CODEC used to encode media for the content, based on transmission parameters (e.g., bit rate) for a data stream providing such media, based on a language for subtitles or other text associated with the specific content, based on other types of data associated with the content, etc. The data stream for each component is encapsulated into packets according to a communication protocol. A user equipment (UE) receiving a transmission of the service identifies desired components based on the common field value.

COUNT I – INFRINGEMENT OF THE '328 PATENT

21. Plaintiff restates and incorporates by reference the foregoing allegations.

22. In violation of 35 U.S.C. § 271(a), Clayton has practiced and continues to practice the method of at least Claim 1 of the '328 Patent by streaming the content found in <https://www.claytonhomes.com/> (“Accused Instrumentality”).

23. Attached hereto as Exhibit 2, and incorporated herein by reference, is a claim chart detailing why the Accused Instrumentality infringes at least method Claim 1.

24. As a result of Defendant’s infringement of the '328 Patent, Plaintiff has suffered damages.

25. Nimitz is entitled to a money judgment in an amount adequate to compensate for Defendant’s infringement, but in no event less than a reasonable royalty for the use made of the invention by Defendant, together with interest and costs as fixed by the Court.

26. Only method claims of the '328 Patent are being asserted, and, thus, patent marking is not an issue. In any event, Nimitz has not commercialized any products under the '328 Patent and has no information that any prior owners of the Patent have not complied with patent marking requirements.

JURY DEMAND

Plaintiff demands a trial by jury on all issues so triable.

PRAYER FOR RELIEF

Plaintiff Nimitz Technologies LLC respectfully requests that the Court find in its favor and against Defendant Clayton Homes, Inc., and that the Court grant Plaintiff the following relief:

A. an adjudication that Defendant had infringed the '328 Patent;

B. an award of damages to be paid by Defendant adequate to compensate Plaintiff for Defendant's past infringement of the '328 Patent, including pre-judgment and post-judgment interest, costs, expenses, and an accounting of all infringing acts; and

C. any and all such further relief at law or in equity that the Court may deem just and proper, including but not limited to attorneys' fees.

Dated: November 30, 2022

Respectfully submitted by:

George Pazuniak (*PHV* to be filed)
O'Kelly & O'Rourke, LLC
824 N. Market Street
Suite 1001A
Wilmington, DE 19801
D: 207-359-8576
gp@del-iplaw.com

/s/Raymond W. Mort, III
Raymond W. Mort, III
100 Congress Ave, Suite 2000
Austin, TX 78701
T: 512-865-7950
raymort@austinlaw.com

Attorney for Plaintiff Nimitz Technologies LLC