

JABURG WILK
LAW FIRM

1 **Jaburg & Wilk, P.C.**
3200 N. Central Avenue, 20th Floor
2 Phoenix, AZ 85012
602.248.1000

3 Maria Crimi Speth (012574)
4 mcs@jaburgwilk.com

5 Alexander D. Brown, Esq. (*Pro Hac Vice* application to be filed)
6 Fla Bar No. 752665
abrown@conceptlaw.com

7 Scott Smiley, Esq. (*Pro Hac Vice* application to be filed)
8 Fla Bar No. 678341
scott@conceptlaw.com

9 Robert C. Kain, Jr., Esq. (*Pro Hac Vice* application to be filed)
10 Fla Bar No. 266760
rkain@conceptlaw.com

11 Zac Davis, Esq. (*Pro Hac Vice* application to be filed)
12 Fla Bar No. 1039020
zdavis@conceptlaw.com

13 Concept Law Group, P.A.
6400 N. Andrews Ave., Ste. 500,
Ft. Lauderdale, FL 33309
Tel: 754.300.1500

14 Attorneys for Plaintiff Joovv, Inc.

17 **UNITED STATES DISTRICT COURT**
18 **FOR THE DISTRICT OF ARIZONA**

19 Joovv, Inc., a Delaware corporation,
20 Plaintiff,

21 v.

22 Mito Red Light, Inc., an Arizona
23 corporation,

24 Defendant.

Case No.

PLAINTIFF'S COMPLAINT
(JURY TRIAL DEMANDED)

1 Plaintiff, JOOVV, INC., a Delaware corporation, files this Complaint for Patent
2 Infringement against Defendant, MITO RED LIGHT, INC., an Arizona corporation, and
3 states:

4
5 **JURISDICTION, VENUE AND THE PARTIES**

6 1. This is an action brought pursuant to the Patent Laws of the United States,
7 35 U.S.C. §§ 271, *et. seq.*

8 2. This Court has original jurisdiction pursuant to Title 28, United States
9 Code, Section 1331, as this case involves a federal question arising under the
10 Constitution, laws, or treaties of the United States.

11 3. At all times material hereto, Joov, Inc., a Delaware corporation, (“Joovv”)
12 had and has its principal address located in Orange County, California.

13 4. At all times material hereto, MITO RED LIGHT, INC., an Arizona
14 corporation, (“Mitored”) has and had its principal address located in Maricopa County,
15 Arizona.

16 5. This action arises as a result of the infringing conduct of Mitored, which
17 implicates interstate commerce.

18 6. Venue is proper in the District of Arizona, Phoenix Division, pursuant to
19 Title 28, United States Code, Section 1400(b), which provides, in part, that “[a]ny civil
20 action for patent infringement may be brought in the judicial district where the defendant
21 resides.”

22 7. All conditions precedent has been met, waived, or satisfied to bring this
23 lawsuit.

24 **GENERAL ALLEGATIONS**

25
26 8. Since 2016, under the JOOVV® brand, Joovv has designed, marketed, and
27 sold a number of market-leading LED red light therapy devices. These LED devices are
28 medical grade and emit LED Red and NIR (Near Infrared) light to optimize a user’s

1 cellular function. Joovv’s products are intended to provide topical heating for the
2 purpose of elevating tissue temperature for: temporary relief of minor muscle pain, joint
3 pain, minor arthritis pain, muscle spasms, temporary increase in local blood circulation,
4 and temporary relaxation of muscles.

5 9. In order to protect its valuable LED light therapy inventions, Joovv has filed
6 for and received several patents covering said inventions, including but not limited to:

7 A. U.S. Patent No. 10,639,495, titled *Photobiomodulation Therapy*
8 *Systems and Methods* (the “495 Patent”) *See Exhibit A*. (This patent was subject to an *Ex*
9 *Parte Reexamination* and was reissued on February 10, 2022);

10 B. U.S. Patent No. 10,828,505, titled *Therapeutic Light Source and*
11 *Hanging Apparatus* (the “505 Patent”) *See Exhibit B*;

12 C. U.S. Patent No. 10,478,635 titled *Photobiomodulation Therapy*
13 *Systems and Methods* (the “635 Patent”) *See Exhibit C*. (This patent was subject to an *Ex*
14 *Parte Reexamination* and was reissued on March 11, 2022);

15 D. U.S. Patent No. 11,253,719 titled *Photobiomodulation Therapy*
16 *Systems and Methods* (the “719 Patent”) *See Exhibit D*;

17 E. U.S. Patent No. 11,033,752 titled *Photobiomodulation Therapy*
18 *Systems and Methods* (the “752 Patent”) *See Exhibit E*;

19 F. U.S. Patent No. 11,524,172 titled *Photobiomodulation Therapy*
20 *Systems and Methods* (the “172 Patent”) *See Exhibit F*;

21 G. U.S. Design Patent No. D963,873 titled *Floor Stand for a*
22 *Photobiomodulation Therapy Device* (the “873 Design Patent”) *See Exhibit G*;

23
24 (collectively, the “Joovv Patents”).

25 10. Mitored is a direct competitor of Joovv and manufactures similar,
26 competitive, albeit inferior, LED light therapy devices marketed under the series names
27 of “Mito Red Original,” “Mito Red Original 2.0,” “MitoMOD,” “MitoMODULAR,”
28 “Mito Red Room,” “MitoPERFORM,” “MitoPERFORM Commercial,” “MitoPRO,”

JABURG WILK
LAW FIRM

1 “MitoPRO Commercial,” and “MitoADAPT.” Mitored also sells racks, stands, multi-
2 light setups, and mounting systems as accessories which are used in combination with
3 its LED light therapy devices (collectively, these LED light therapy devices, racks,
4 stands and mounting systems are “Accused Infringing Products”). These Accused
5 Infringing Products were and are offered for sale *at least* on Mitored’s website, at
6 <https://mitoredlight.com/>.

7 11. Mitored began selling the Accused Infringing Products in or around 2019 –
8 approximately two (2) years after Joovv began selling its Products. Mitored’s and
9 Joovv’s products are strikingly similar as shown below.

10 Joovv’s LED therapy light panels

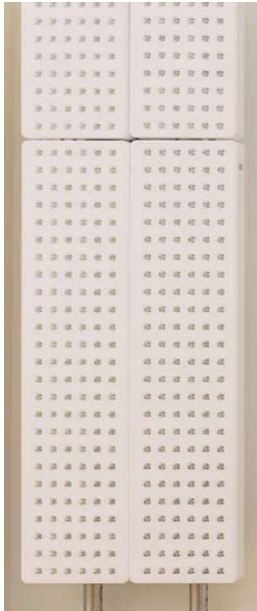

11 Mitored’s LED therapy light panels

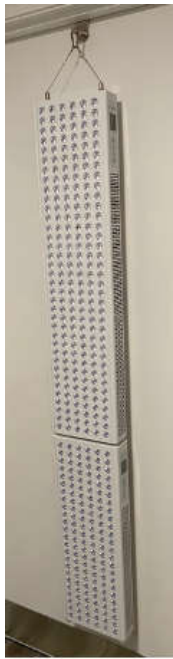

12
13
14
15
16
17
18
19
20
21
22
23 12. In or around late 2019, Joovv first became aware that Mitored was making,
24 using, advertising, and selling one or more light therapy devices, namely, the Accused
25 Infringing Products, which read on, *at a minimum*, one or more patent claims in the ’635
26 Patent.

27 13. Accordingly, on January 20, 2020, counsel for Joovv placed Mitored on
28 written notice of same and demanded that it cease all marketing and sales of products

1 reading upon any of the claims of the ‘635 Patent. *See* Composite Exhibit H, pg. 2. A
2 preliminary infringement analysis comparing the patent claims to a Mitored product was
3 included as an exhibit to the letter.

4 14. Mitored’s only response indicated they obtained patent counsel and that
5 further communications should be directed to such counsel. *See* Composite Exhibit H,
6 pg. 7.

7 15. Then, in 2020, the USPTO issued the ’495 and ’505 Patents. Also in April
8 2020, the USPTO indicated that it would approve, as being patentable, claims in the
9 then-pending patent application that matured into the ‘752 Patent.

10 16. Therefore, on April 5, 2021, Joovv’s counsel sent another letter notifying
11 Mitored that the Accused Infringing Products also infringed one or more of the Joovv
12 Patents, namely the ‘505 and the ‘495 Patents, including the approved, but not yet issued,
13 ‘752 Patent. *See* Composite Exhibit H, pg. 8.

14 17. Once again, Mitored failed to substantively respond and its infringing
15 conduct has continued to this day.

16 18. In 2021, the USPTO issued the ‘752 Patent to Joovv. *See* Exhibit E.

17 19. Meanwhile, in and around the same time frame during which Joovv was
18 communicating with Mitored demanding cessation of its infringing conduct, Joovv
19 continued to police its patent portfolio across the industry.

20 20. In such policing efforts, Joovv also demanded the cessation of infringement
21 activity by Platinum LED Holdings, LLC (“Platinum LED”).

22 21. As a direct consequence of Joovv’s policing enforcement efforts, the ‘495
23 Patent and ‘635 Patent became the subject of *ex parte* reexamination proceedings before
24 the USPTO initiated by infringer Platinum LED. Such efforts, however, failed as both
25 patents were reissued on February and March 2022, respectively.

26 22. Also in 2022, the USPTO issued the ‘719 Patent, the ‘172 Patent and the
27 ‘873 Design Patent to Joovv.

28

1 23. Following the reissuance of the ‘495 Patent and ‘635 Patent with
2 reexamination certificates, Joovv recommenced its enforcement efforts and, on May 31,
3 2022, instituted patent infringement litigation under the style, *Joovv, Inc. v. Platinum*
4 *LED Holdings, LLC*, Case No. 6:22-cv-00965 (S.D. Fla.) (hereinafter the “Platinum LED
5 Litigation”).

6 24. On March 21, 2023, the Platinum LED Litigation concluded, *in part*,
7 through entry of a Consent Injunction whereby Platinum LED is forever enjoined from
8 infringing on any of Joovv’s patents.

9 25. With the conclusion of the Platinum LED Litigation, Joovv was able to
10 refocus its policing efforts on Mitored, at which time it became clear that Mitored
11 continued its cavalier and reckless attitude towards its misappropriation of Joovv’s
12 intellectual property.

13 26. This litigation was thus necessitated by Mitored’s continued unlawful
14 conduct.

15 27. To be clear, Mitored’s actions are harmful inasmuch as the Joovv Patents
16 inure economic benefit to Joovv as Joovv makes, uses, sells, and/or offers for sale LED
17 light therapy devices that are the same or substantially similar to those devices claimed
18 in the Joovv Patents.

19 28. The Joovv Patents are in force and enjoy a presumption of validity pursuant
20 to 35 U.S.C. § 282.

21 29. Mitored continues to make, sell, offer for sale, use, and/or have, directly or
22 indirectly, unjustly received and retained profits from the Accused Infringing Products
23 in the United States.

24 30. As demonstrated by its willful disregard of Joovv’s notice letters and
25 intellectual property rights, Mitored has long been aware that the Accused Infringing
26 Products infringe upon the Joovv Patents and that making, using, selling, and offering
27 the Accused Infringing Products for sale in the United States is prohibited by United
28 States law, specifically 35 U.S.C. § 271.

JABURG WILK
LAW FIRM

1 31. Joovv marks its light therapy devices as being patented and its website lists
2 the aforementioned patents, thereby giving further notice to Mitored, Joovv’s
3 competitors, and the public of its patent rights. See <https://joovv.com/pages/patent>.

4 32. Mitored does not have a license, sub-license, or other authorization from
5 Joovv to make, use, sell, or offer to sell the Accused Infringing Products or any product
6 which reads on the claims of the Joovv Patents in the United States.

7 33. Mitored is actively selling, distributing, selling, and/or offering for sale the
8 Accused Infringing Products as well as promoting, advertising, and instructing others to
9 use the Accused Infringing Products thereby inducing others to infringe Joovv’s Patents,
10 all with the knowledge and intent that such sales, promotions, and instructions are being
11 made without authority of Joovv.

12 34. Joovv has suffered damages, lost profits and other economic harm as a
13 direct and proximate result of Mitored’s infringement of the Joovv Patents.

14 35. Joovv has and continues to suffer irreparable harm as a result of Mitored’s
15 infringement.

16 36. Joovv has no adequate remedy at law.

17 37. Justice and the balance of the equities favor entry of permanent injunctive
18 relief restraining and enjoining Mitored, and those acting in concert with it, or at their
19 direction, from making, using, selling, or offering for sale products that infringe upon
20 the Joovv Patents and from promoting, advertising, instructing and inducing others to
21 infringe the Joovv Patents.

22 38. As a direct and proximate result of Mitored’s actions, Joovv has been forced
23 to incur litigation costs and retain the undersigned law firm to represent them in this
24 action and has agreed to pay them a reasonable fee for their services.

25

26

27

28

COUNT I – WILLFUL PATENT INFRINGEMENT

(’495 Patent)

39. Plaintiff realleges and re-avers all paragraphs of this Complaint as if fully set forth herein.

40. This is an action for direct and indirect patent infringement pursuant to Title 35, United States Code, Section 271 of the United States Patent Act.

41. Mitored has infringed and continues to infringe, literally and under the doctrine of equivalents, *at least* Claim 1 of the ’495 Patent by making, using, selling, and/or offering for sale the Accused Infringing Products. A claims chart demonstrating Mitored’s infringement of *at least* Claim 1 of the ’495 Patent through its marketing and sale of an exemplary number of the Accused Infringing Products is attached as *Exhibit I*.

42. Separately, Mitored’s actions have induced and continue to induce consumers to infringe one or more claims of Joovv’s ’495 Patent by continuing to manufacture, market and sell the Accused Infringing Products directly to consumers while providing instructions on how to operate the Accused Infringing Products. *See id.*

43. All such infringing conduct of Mitored has occurred and was committed in a willful manner by at least its knowledge of the ’495 Patent and having received specific accusations of infringement and preliminary claims charts in Joovv’s multiple notice letters, all to no avail. *See* Composite Exhibit H, pg. 8.

44. Moreover, Joovv marks its patented products and publicly lists its patents, including the ’495 Patent, prominently on its website, thereby giving Mitored even further notice of Joovv’s patent rights.

45. Mitored’s actions have caused and continue to cause irreparable harm to Joovv, for which there is no adequate remedy at law.

46. Mitored’s conduct in this instance is exceptional, and, as such, Joovv should be entitled to recover, inter alia, treble damages, and to recoup its attorneys’ fees in this

JABURG WILK
LAW FIRM

1 action pursuant to 35 USC § 285, which provides that the “court in exceptional cases
2 may award reasonable attorney fees to the prevailing party.”

3
4 **COUNT II – WILLFUL PATENT INFRINGEMENT**

5 **(’505 Patent)**

6 47. Plaintiff realleges and re-avers all paragraphs of this Complaint as if fully
7 set forth herein.

8 48. This is an action for direct and indirect patent infringement pursuant to Title
9 35, United States Code, Section 271 of the United States Patent Act.

10 49. Mitored has infringed and continues to infringe, literally and under the
11 doctrine of equivalents, *at least* Claim 1 of the ’505 Patent by making, using, selling,
12 and/or offering for sale the Accused Infringing Products. A claims chart demonstrating
13 Mitored’s infringement of *at least* Claim 1 of the ’505 Patent through its marketing and
14 sale of an exemplary number of the Accused Infringing Products are attached as *Exhibit*
15 *J*.

16 50. Separately, Mitored’s actions have induced and continue to induce
17 consumers to infringe one or more claims of Joovv’s ’505 Patent by continuing to
18 manufacture, market and sell the Accused Infringing Products directly to consumers
19 while providing instructions on how to operate the Accused Infringing Products. *See id.*

20 51. All such infringing conduct of Mitored has occurred and was committed in
21 a willful manner by at least its knowledge of the ’505 Patent and having received specific
22 accusations of infringement and preliminary claims charts in Joovv’s multiple notice
23 letters, all to no avail. *See* Composite Exhibit H, pg. 8.

24 52. Moreover, Joovv marks its patented products and publicly lists its patents,
25 including the ’505 Patent, prominently on its website, thereby giving Mitored even
26 further notice of Joovv’s patent rights.

27 53. Mitored’s actions have caused and continue to cause irreparable harm to
28 Joovv, for which there is no adequate remedy at law.

1 54. Mitored’s conduct in this instance is exceptional, and, as such, Joovv should
2 be entitled to recover, *inter alia*, treble damages, and to recoup its attorneys’ fees in this
3 action pursuant to 35 USC § 285, which provides that the “court in exceptional cases
4 may award reasonable attorney fees to the prevailing party.”
5

6 **COUNT III – WILLFUL PATENT INFRINGEMENT**

7 **(’635 Patent)**

8
9 55. Plaintiff realleges and re-avers all paragraphs of this Complaint as if fully
10 set forth herein.

11 56. This is an action for direct and indirect patent infringement pursuant to Title
12 35, United States Code, Section 271 of the United States Patent Act.

13 57. Mitored has infringed and continues to infringe, literally and under the
14 doctrine of equivalents, *at least* Claim 1 of the ’635 Patent by making, using, selling,
15 and/or offering for sale the Accused Infringing Products. A claims chart demonstrating
16 Mitored’s infringement of *at least* Claim 1 of the ’635 Patent through its marketing and
17 sale of an exemplary number of the Accused Infringing Products is attached as *Exhibit*
18 *K*.

19 58. Separately, Mitored’s actions have induced and continue to induce
20 consumers to infringe one or more claims of Joovv’s ’635 Patent by continuing to
21 manufacture, market and sell the Accused Infringing Products directly to consumers
22 while providing instructions on how to operate the Accused Infringing Products. *See id.*

23 59. All such infringing conduct of Mitored has occurred and was committed in
24 a willful manner by at least its knowledge of the ’635 Patent and having received specific
25 accusations of infringement and preliminary claims charts in Joovv’s multiple notice
26 letters, all to no avail. *See* Composite Exhibit H, pg. 2.

27 60. Moreover, Joovv marks its patented products and publicly lists its patents,
28 including the ’635 Patent, prominently on its website, thereby giving Mitored even
further notice of Joovv’s patent rights.

JABURG WILK
LAW FIRM

1 patents, including the '719 Patent, prominently on its website. Having received specific
2 accusations of infringement for these four (4) Joovv Patents and provided public access
3 to Joovv's website, Mitored was on notice of the '719 Patent.

4 69. Mitored's actions have caused and continue to cause irreparable harm to
5 Joovv, for which there is no adequate remedy at law.

6 70. Mitored's conduct in this instance is exceptional, and, as such, Joovv should
7 be entitled to recover, *inter alia*, treble damages, and to recoup its attorneys' fees in this
8 action pursuant to 35 USC § 285, which provides that the "court in exceptional cases
9 may award reasonable attorney fees to the prevailing party."

10
11 **COUNT V – WILLFUL PATENT INFRINGEMENT**

12 **('752 Patent)**

13 71. Plaintiff realleges and re-avers all paragraphs of this Complaint as if fully
14 set forth herein.

15 72. This is an action for direct and indirect patent infringement pursuant to Title
16 35, United States Code, Section 271 of the United States Patent Act.

17 73. Mitored has infringed and continues to infringe, literally and under the
18 doctrine of equivalents, *at least* Claim 1 of the '752 Patent by making, using, selling,
19 and/or offering for sale the Accused Infringing Products. A claims chart demonstrating
20 Mitored's infringement of *at least* Claim 1 of the '752 Patent through its marketing and
21 sale of an exemplary number of the Accused Infringing Products is attached as *Exhibit*
22 *M*.

23 74. Separately, Mitored's actions have induced and continue to induce
24 consumers to infringe one or more claims of Joovv's '752 Patent by continuing to
25 manufacture, market and sell the Accused Infringing Products directly to consumers
26 while providing instructions on how to operate the Accused Infringing Products. *See id.*

27 75. All such infringing conduct of Mitored has occurred and was committed in
28 a willful manner by at least its knowledge of the '752 Patent and having received specific

1 accusations of infringement from and preliminary claims charts in Joovv’s notice letters
2 referencing the U.S. Patent Publication No. 2020/0121944, all to no avail. *See*
3 Composite Exhibit H, pg. 8.

4 76. Moreover, Joovv marks its patented products and publicly lists its patents,
5 including the ‘752 Patent, prominently on its website, thereby giving Mitored even
6 further notice of Joovv’s patent rights.

7 77. Mitored’s actions have caused and continue to cause irreparable harm to
8 Joovv, for which there is no adequate remedy at law.

9 78. Mitored’s conduct in this instance is exceptional, and, as such, Joovv should
10 be entitled to recover, *inter alia*, treble damages, and to recoup its attorneys’ fees in this
11 action pursuant to 35 USC § 285, which provides that the “court in exceptional cases
12 may award reasonable attorney fees to the prevailing party.”

13
14 **COUNT VI – WILLFUL PATENT INFRINGEMENT**

15 **(’172 Patent)**

16 79. Plaintiff realleges and re-avers all paragraphs of this Complaint as if fully
17 set forth herein.

18 80. This is an action for direct and indirect patent infringement pursuant to Title
19 35, United States Code, Section 271 of the United States Patent Act.

20 81. Mitored has infringed and continues to infringe, literally and under the
21 doctrine of equivalents, *at least* Claim 1 of the ’172 Patent by making, using, selling,
22 and/or offering for sale the Accused Infringing Products. A claims chart demonstrating
23 Mitored’s infringement of at least Claim 1 of the ’172 Patent through its marketing and
24 sale of an exemplary number of the Accused Infringing Products is attached as *Exhibit*
25 *N*.

26 82. Separately, Mitored’s actions have induced and continue to induce
27 consumers to infringe one or more claims of Joovv’s ‘752 Patent by continuing to
28

JABURG WILK
LAW FIRM

1 manufacture, market and sell the Accused Infringing Products directly to consumers
2 while providing instructions on how to operate the Accused Infringing Products. *See id.*

3 83. All such infringing conduct of Mitored has occurred and will continue to
4 occur.

5 84. All such infringing conduct of Mitored has occurred and was committed in
6 a willful manner because Mitored had actual notice of its infringement of the ‘635, ‘495,
7 ‘505, and ‘752 Patents and Joovv marks its patented products and publicly lists its
8 patents, including the ‘172 Patent, prominently on its website. Having received specific
9 accusations of infringement for these four (4) Joovv Patents and provided access to
10 Joovv’s website, Mitored was on notice of the ‘172 Patent.

11 85. Mitored’s actions have caused and continue to cause irreparable harm to
12 Joovv, for which there is no adequate remedy at law.

13 86. Mitored’s conduct in this instance is exceptional, and, as such, Joovv should
14 be entitled to recover, *inter alia*, treble damages, and to recoup its attorneys’ fees in this
15 action pursuant to 35 USC § 285, which provides that the “court in exceptional cases
16 may award reasonable attorney fees to the prevailing party.”

17
18 **COUNT VII – WILLFUL PATENT INFRINGEMENT**

19 **(‘873 Design Patent)**

20 87. Plaintiff realleges and re-avers all paragraphs of this Complaint as if fully
21 set forth herein.

22 88. This is an action for direct and indirect patent infringement pursuant to Title
23 35, United States Code, Section 271 of the United States Patent Act.

24 89. Mitored has infringed and continues to infringe, literally and under the
25 doctrine of equivalents, the ‘873 Design Patent by making, using, selling, and/or offering
26 for sale the stand used in connection with the Accused Infringing Products, said stand
27 which is ornamentally designed in a substantially similar manner as that described in the
28 ‘873 Design Patent.

1 90. For example, the compared images below demonstrate that Mitored’s stand
2 has been ornamentally designed in a substantially similar manner as that described in the
3 ‘873 Design Patent:

4
5 ‘873 Design Patent

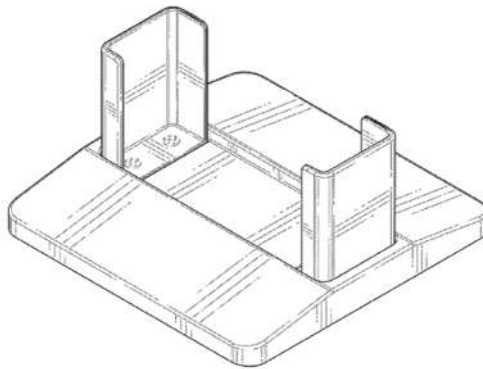

6
7 Mitored’s Floor Stand Design



8
9
10
11
12
13 91. All such infringing conduct of Mitored has occurred and will continue to
14 occur.

15 92. All such infringing conduct of Mitored has occurred and was committed in
16 a willful manner, *inter alia*, because Mitored had notice of its infringement of the ‘635,
17 ‘495, ‘505, and ‘752 Patents, and because Joovv marks its patented products and publicly
18 lists its patents, including the ‘873 Design Patent, prominently on its website. Having
19 received specific accusations of infringement for these four (4) Joovv Patents and
20 provided access to Joovv’s website, Mitored was on notice of the ‘873 Design Patent.
21

22 93. Mitored’s actions have caused and continue to cause irreparable harm to
23 Joovv, for which there is no adequate remedy at law.

24 94. Mitored’s conduct in this instance is exceptional, and, as such, Joovv should
25 be entitled to recover, *inter alia*, treble damages wherever allowable, and to recoup its
26 attorneys’ fees in this action pursuant to 35 USC § 285, which provides that the “court
27 in exceptional cases may award reasonable attorney fees to the prevailing party.”
28

JABURG WILK
LAW FIRM

1
2
3
4
5
6
7
8
9
10
11
12
13
14
15
16
17
18
19
20
21
22
23
24
25
26
27
28

PRAYER FOR RELIEF

WHEREFORE, Joovv respectfully demands judgment against Mitored, said judgment which should include provisions:

1. Permanently enjoining Mitored and all of those acting in concert with it, including, but not limited to, their agents, affiliates, subsidiaries, officers, directors, attorneys and employees from using, making, selling, or offering to sell the Accused Infringing Products, and all colorable imitations and variations thereof;

2. Compensating Joovv for the full amount of damages sustained, including, but not limited to, any and all damage remedies available pursuant to the Patent Laws of the United States, 35 U.S.C. §§ 271, *et. seq.*, which include, but are not limited to, lost profits, a reasonable royalty award, and, in the case of the ‘873 Design Patent, disgorgement of profits;

3. Declaring this case exceptional and trebling all damages awarded to Joovv;

4. Imposition of all pre- and post-judgment interest at the maximum allowable rate on the full compensatory and trebled amount awarded to Joovv;

5. Awarding remuneration of all attorneys’ fees (pursuant to 35 USC § 285), costs and expenses for Joovv having to investigate, prepare and prosecute this action; and

6. For such further and additional relief this Court deems just and proper under the circumstances.

PRAYER FOR RELIEF

Joovv demands a trial by jury of all issues so triable as a matter of law.

. . . .
. . . .
. . . .

DATED this 13th day of June, 2023.

Jaburg & Wilk, P.C.

/s/Maria Crimi Speth
Maria Crimi Speth
3200 N. Central Avenue, 20th Floor
Phoenix, AZ 85012

Alexander D. Brown, Esq. (Pro Hac Vice application to be filed)
Fla. Bar No. 752665
abrown@conceptlaw.com
Scott Smiley, Esq. (Pro Hac Vice application to be filed)
Fla. Bar No. 678341
scott@conceptlaw.com
Robert C. Kain, Jr., Esq. (Pro Hac Vice application to be filed)
Fla Bar No. 266760
rkain@conceptlaw.com
Zac Davis, Esq. (Pro Hac Vice application to be filed)
Fla Bar No. 1039020
zdavis@conceptlaw.com
CONCEPT LAW GROUP, P.A.
6400 N. Andrews Ave., Ste. 500,
Ft. Lauderdale, FL 33309
Tel: 754.300.1500

Attorneys for Plaintiff Joovv, Inc.

JABURG WILK
LAW FIRM

1
2
3
4
5
6
7
8
9
10
11
12
13
14
15
16
17
18
19
20
21
22
23
24
25
26
27
28