

1 Eric G. Maurer (GA Bar # 478199)
(*pro hac vice forthcoming*)
2 Email: e.maurer@thip.law
3 Cynthia J. Lee (GA Bar # 442999)
(*pro hac vice forthcoming*)
4 Email: c.lee@thip.law
THOMAS | HORSTEMEYER, LLP
5 3200 Windy Hill Road, Suite 1600E
Atlanta, Georgia 30339
6 Telephone: 770-933-9500
Fax: 770-951-0933

7 J. Mark Holland (CA Bar No. 140453)
Email: mholland@jmhlaw.com
8 **J. MARK HOLLAND & ASSOCIATES**
a Professional Law Corporation
9 19800 MacArthur Boulevard, Suite 300
Irvine, CA 92612
10 Telephone: (949) 718-6750
Facsimile: (949) 718-6756

11 *Counsel for Plaintiff Danco, Inc.*

12
13 IN THE UNITED STATES DISTRICT COURT
14 CENTRAL DISTRICT OF CALIFORNIA
SOUTHERN DIVISION

15 DANCO, INC. a Delaware corporation, } Civil Action No. _____
16 Plaintiff, }
17 v. } **COMPLAINT FOR PATENT**
18 FLUIDMASTER, INC., a California } **INFRINGEMENT**
19 corporation; and DOES 1 THROUGH } **JURY TRIAL DEMANDED**
20 5, inclusive, }
Defendants. }

21 Plaintiff Danco, Inc. (“Danco”), by and through its undersigned attorneys,
22 files this Complaint for Patent Infringement against Defendant Fluidmaster, Inc.
23 (“Fluidmaster”), and in support thereof alleges as follows:

24
25 **NATURE AND BASIS OF THE ACTION**

26 1. This is an action for patent infringement under the patent laws of the
27 United States, 35 U.S.C. § 1 *et seq.* Danco seeks damages and recovery of its
28

**COMPLAINT
FOR PATENT INFRINGEMENT**

Civ. Action No. _____ T

1 reasonable costs and attorneys' fees.

2 1. Plaintiff Danco is one of the largest plumbing repair, replacement, and
3 remodel suppliers in the home improvement industry. Danco offers for sale its
4 innovative plumbing solutions through various nationwide retailers, such as Home
5 Depot, Lowe's, and Menards.
6

7
8 2. Danco's history of innovation in the plumbing industry and innovative
9 plumbing solutions have resulted in the issuance of dozens of patents on its industry-
10 leading, consumer-driven patented solutions, including, but not limited to, the toilet
11 fill valves disclosed in U.S. Patent Nos. 9,103,105 ("the '105 Patent"), 9,139,993
12 ("the '993 Patent"), and 10,934,698 ("the '698 Patent"), collectively the Danco Fill
13 Valve Patents. True and correct copies of the Danco Fill Valve Patents are attached
14 hereto as Exhibits A, B, and C, respectively.
15

16
17 3. Fluidmaster is a manufacturer, supplier, seller, and/or distributor of
18 plumbing and repair products.
19

20 4. Fluidmaster has made and continues to make, has used and continues
21 to use, has offered for sale and continues to offer, and has sold and continues to sell
22 various toilet fill valves under its own brand, such as, for example, at least the
23 Fluidmaster PRO45U, PRO45HR, 400H, 400AH, and 400H-002 ("the Accused
24 Products"), as discussed in more detail below.
25
26
27
28

1 5. The Accused Products have been and continue to be offered for sale
2 and sold in the United States through various retailers and/or distributors, including
3 nationwide retailers such as Home Depot and Ferguson.
4

5 6. By making, using, offering for sale, selling, and/or importing the
6 Accused Products, Fluidmaster has infringed and continues to infringe one or more
7 claims of the Danco Fill Valve Patents. As a consequence of Fluidmaster’s
8 infringement, Danco seeks a preliminary injunction, a permanent injunction, and
9 monetary damages with respect to sales of the Accused Products. Moreover, Danco
10 respectfully submits that, upon information and belief, the present case is
11 exceptional and Danco is entitled to enhanced damages against Fluidmaster and an
12 award of its reasonable attorneys’ fees and costs.
13
14
15

16 **THE PARTIES**

17 7. Plaintiff Danco, Inc. is a Delaware corporation having its principal
18 place of business at 2727 Chemsearch Boulevard, Irving, Texas 75062.
19

20 8. Upon information and belief, Defendant Fluidmaster, Inc., is a
21 California corporation having a regular and established place of business at 30800
22 Rancho Viejo Road, San Juan Capistrano, California 92675. Upon further
23 information and belief, Fluidmaster may be served by serving its Registered Agent
24 Robert Adolf Andersonschoepe at its registered address of 30800 Rancho Viejo
25 Road, San Juan Capistrano, California 92675.
26
27
28

JURISDICTION AND VENUE

1
2 9. This Court has jurisdiction over the subject matter of this action
3 pursuant to 28 U.S.C. § 1331 and 1338(a) because this Complaint includes a cause
4 of action for patent infringement under the patent laws of the United States,
5 including, but not limited to, 35 U.S.C. §§ 271, 281, 283-285, and 287.
6

7
8 10. This Court has personal jurisdiction over Fluidmaster by virtue of the
9 fact that Fluidmaster resides in this District, has transacted business in this District,
10 has derived substantial revenue from goods offered for sale and/or sold in this
11 District, and/or has established sufficient minimum contacts with the State of
12 California such that it is subject to the personal jurisdiction of this Court. Personal
13 jurisdiction in California over Fluidmaster is also consistent with the requirements
14 of due process.
15

16
17 11. Venue is proper in this district under 28 U.S.C. §§ 1391 and 1400(b)
18 because Fluidmaster resides in this District, has a regular and established place of
19 business in this District located at 30800 Rancho Viejo Road, San Juan Capistrano,
20 California 92675, has committed acts of infringement in this District, and a
21 substantial part of the events or omissions giving rise to the claims occurred in this
22 District.
23
24
25
26
27
28

DANCO AND ITS PATENT RIGHTS

1
2 12. Danco has invested a substantial amount of time and resources
3 designing, developing, and bringing new and innovative products in the plumbing
4 industry.
5

6 13. Danco has designed and developed a wide range of new and innovative
7 plumbing connector products, including a number of innovative toilet fill valves.
8 Specifically, Danco research and development staff designed and developed a
9 number of innovative toilet fill valves that allow for the installation or replacement
10 of toilet fill valves without tools and saving of water.
11
12

13 14. As a result of these efforts, Danco has been granted a number of U.S.
14 patents on its innovative fill valves, including the Danco Fill Valve Patents.
15

16 15. The application for the ‘105 Patent, entitled “Toilet Fill Valve,” was
17 filed on August 12, 2014, and was duly and legally issued as U.S. patent by the
18 United States Patent and Trademark Office (“USPTO”) on August 11, 2015. *See*
19 Exhibit A.
20

21 16. The application for the ‘993 Patent, entitled “Toilet Fill Valve,” was
22 filed on January 27, 2014, and was duly and legally issued as U.S. patent by the
23 United States Patent and Trademark Office (“USPTO”) on September 22, 2015. *See*
24 Exhibit B.
25
26
27
28

1 17. The application for the '968 Patent, entitled "Toilet Valve," was filed
2 on November 18, 2019, and was duly and legally issued as U.S. patent by the United
3 States Patent and Trademark Office ("USPTO") on March 2, 2021. *See* Exhibit C.
4

5 18. Danco is the owner by assignment of all rights, title, and interest in and
6 to the Danco Fill Valve Patents, including the right to make, use, offer for sale, sell,
7 or import patented products and to enforce the Danco Fill Valve Patents.
8

9 **FLUIDMASTER'S INFRINGING CONDUCT**

10 19. Fluidmaster has made and continues to make, has used and continues
11 to use, has offered for sale and continues to offer for sale, and has sold and
12 continues to sell various toilet fill valves under its own brand, such as, for example,
13 at least the Fluidmaster PRO45U, PRO45HR, 400H, 400AH, and 400H-002
14 products.
15
16

17 20. The Fluidmaster Accused Products have been made available for
18 retail sale by Fluidmaster and/or through various nationwide retailers, such as, for
19 example, Home Depot, Lowe's, Menards and/or Ace Hardware, as well as through
20 wholesalers/distributors such as Ferguson.
21

22 21. Upon information and belief, Fluidmaster has known of and has had
23 actual knowledge of the Danco Fill Valve Patents.
24

25 22. As discussed in more detail below, the Fluidmaster Accused Products
26 have infringed and continue to infringe, directly and indirectly, at least:
27
28

1 a. Claims 1, 9, 15, and 24 of the ‘105 Patent;

2 b. Claims 1, 8, and 14 of the ‘993 Patent;

3 and

4 c. Claims 1, 12, 17, and 22 of the ‘698 Patent

5
6 by Fluidmaster’s making, using, importing, selling, and/or offering to sell the
7
8 Accused Products within the United States and without authority in violation of 35
9 U.S.C. §§ 271(a)-(c).

10 23. Fluidmaster has directly infringed and continues to directly infringe,
11
12 literally or under the doctrine of equivalents, at least the above-identified claims of
13
14 the Danco Fill Valve Patents by, without authority, making, using, importing,
15
16 selling, or offering to sell the Accused Products within the United States in
17
18 violation of 35 U.S.C. § 271(a).

19 24. Fluidmaster has indirectly infringed and continues to indirectly
20
21 infringe at least the above-identified claims of the Danco Fill Valve Patents within
22
23 the United States by inducement under 35 U.S.C. § 271(b). For example,
24
25 Fluidmaster has knowingly and intentionally induced users of the Accused
26
27 Products to directly infringe at least the above-identified claims of the Danco Fill
28
29 Valve Patents, *inter alia*, by i) providing installation instructions on how to install
30
31 and use the Accused Products in an infringing manner, and ii) directing and

1 encouraging the actions of employees, distributors, and customers to directly
2 infringe.

3
4 25. Fluidmaster has indirectly infringed and continues to infringe at least
5 the above-identified claims of the Danco Fill Valve Patents by contributing to the
6 direct infringement of end users under 35 U.S.C. § 271(c) by providing the
7
8 Accused Products, which were especially made for and used in a manner that
9 infringed at least the above-identified claims of the Danco Fill Valve Patents, and
10 that had no substantial non-infringing use.

11
12 26. By such acts, Fluidmaster has injured Danco and is thus liable to
13 Danco for infringement of the above-identified claims of the Danco Fill Valve
14 Patents pursuant to 35 U.S.C. § 271.

15
16 **COUNT I – DIRECT INFRINGEMENT OF THE DANCO FILL VALVE**

17
18 **PATENTS BY FLUIDMASTER**

19 27. Danco incorporates and re-alleges the allegations contained in
20 Paragraphs 1 through 31 above as if fully set forth herein.

21
22 28. Fluidmaster has directly infringed and continues to infringe, literally
23 or under the doctrine of equivalents, at least the above-identified claims of the
24 Danco Fill Valve Patents by, without authority, making, using, importing, selling,
25 or offering to sell the Accused Products within the United States in violation of 35
26 U.S.C. § 271(a).

1 29. As an example, a summary of Fluidmaster’s infringement of claim 1
2 of the ’105 Patent is provided as follows:

- 3 a. Limitation 1: The Accused Products include a toilet fill valve;
4
5 b. Limitation 2: The body of the valve has an extended portion,
6 wherein the extended portion is integrally molded with the
7 body, wherein the extended portion forms a bowl fill outlet
8 port;
9
10 c. Limitation 3: The valve has a water inlet configured to receive
11 water from a water source; and
12
13 d. Limitation 4: The valve has a tank water outlet configured to
14 provide a first portion of the water to a toilet tank during at least
15 a portion of a flush cycle.
16
17 e. Limitation 5: The valve includes diverter inserts (water flow
18 regulators) that are configured to attach directly to the extended
19 portion of the valve body, wherein a portion of the diverter
20 insert is configured to insert into, and come into contact with,
21 the extended portion of the valve body, wherein the diverter
22 insert is configured to receive a second portion of the water
23 from the bowl fill outlet port during at least a portion of the
24 flush cycle, wherein the diverter insert is configured to constrict
25
26
27
28

1 a flow rate of the second portion of the water that flows through
2 the diverter insert.

- 3 f. Limitation 6: The valve includes a tube that is configured
4 to attach directly to the diverter inserts, wherein the tube is
5 configured to direct the second portion of the water from the
6 bowl fill restriction directly to a toilet tank overflow tube
7
8

9 Accordingly, Fluidmaster's Accused Products directly infringe at least claim 1 of
10 the '105 Patent in violation of 35 U.S.C. § 271(a).
11

12 34. As a result of Fluidmaster's infringement of the Danco Fill Valve
13 Patents, Danco has been damaged by Fluidmaster's unlawful conduct. Danco is
14 entitled to recover damages pursuant to 28 U.S.C. § 284 adequate to compensate
15 it for Fluidmaster's infringing activities in an amount to be determined at trial, but
16 in no event less than a reasonable royalty.
17
18

19 35. Fluidmaster's infringement of the Danco Fill Valve Patents has
20 injured and continues to injure Danco and will cause irreparable harm unless
21 Fluidmaster is enjoined from infringing the claims of the Danco Fill Valve Patents.
22 Accordingly, Danco is entitled to temporary, preliminary, and/or permanent
23 injunctive relief against Fluidmaster from further infringement pursuant to 35
24 U.S.C. § 283.
25
26
27
28

1 36. Upon information and belief, Fluidmaster’s infringement of the
2 Danco Fill Valve Patents has been deliberate, willful, which warrants an award of
3 treble damages and attorneys' fees to Danco pursuant to 28 U.S.C. §§ 284 & 285.
4

5 **COUNT II – INDUCED INFRINGEMENT OF THE DANCO FILL VALVE**

6 **PATENTS**

7
8 37. Danco incorporates and re-alleges the allegations contained in
9 Paragraphs 1 through 36 above as if fully set forth herein.

10 38. Upon information and belief, since at least as early as 2012
11 Fluidmaster has known of and has had actual knowledge one or more of the
12 applications that issued as one or more of the Danco Fill Valve Patents, and since
13 at least as early as 2015 Fluidmaster has known of and has had actual knowledge
14 of one or more of the Danco Fill Valve Patents.
15

16 39. Fluidmaster directed, instructed, and encouraged its employees,
17 distributors, and/or customers to make, install and/or use the Accused Products in
18 an infringing manner in its product packaging and product advertising, by
19 providing support and technical assistance, and by providing installation
20 instructions or instructional materials, among other acts.
21

22 40. When the Accused Products were used by Fluidmaster’s employees,
23 distributors, and customers in the manner instructed and directed by Fluidmaster,
24
25
26
27
28

1 Fluidmaster's employees, distributors, and customers directly infringed at least the
2 above-referenced claims of the Danco Fill Valve Patents, as set forth above.

3 41. Accordingly, Fluidmaster indirectly infringed the Danco Fill Valve
4 Patents by inducing infringement of the Danco Fill Valve Patents, pursuant to 35
5 U.S.C. § 271(b).
6

7 42. As a result of Fluidmaster's infringement of the Danco Fill Valve
8 Patents, Danco has been damaged by Fluidmaster's unlawful conduct. Danco is
9 entitled to recover damages pursuant to 28 U.S.C. § 284 adequate to compensate it
10 for Fluidmaster's infringing activities in an amount to be determined at trial, but in
11 no event less than a reasonable royalty.
12

13 43. Fluidmaster's infringement of the Danco Fill Valve Patents has
14 injured and continues to injure Danco and will cause irreparable harm unless
15 Fluidmaster is enjoined from infringing the claims of the Danco Fill Valve Patents.
16 Accordingly, Danco is entitled to temporary, preliminary, and/or permanent
17 injunctive relief against Fluidmaster from further infringement pursuant to 35
18 U.S.C. § 283.
19

20 44. Upon information and belief, Fluidmaster's past and continued
21 infringement of the Danco Fill Valve Patents has been deliberate, willful, which
22 warrants an award of treble damages and attorneys' fees to Danco pursuant to 28
23 U.S.C. §§ 284 & 285.
24
25
26
27
28

COUNT III – CONTRIBUTORY INFRINGEMENT OF THE DANCO FILL

VALVE PATENTS

1
2
3
4 45. Danco incorporates and re-alleges the allegations contained in
5 Paragraphs 1 through 44 above as if fully set forth herein.

6 46. Upon information and belief, since at least as early as 2012
7
8 Fluidmaster has known of and has had actual knowledge one or more of the
9 applications that issued as one or more of the Danco Fill Valve Patents, and since
10 at least as early as 2015 Fluidmaster has known of and has had actual knowledge
11 of one or more of the Danco Fill Valve Patents.

12
13 47. Fluidmaster has provided its distributors and customers with the
14
15 Accused Products, which are essential to practice the inventions of the Danco Fill
16 Valve Patents.

17
18 48. Fluidmaster was aware that the Accused Products were especially
19 made for or adapted for use in a manner that infringed at least the above-referenced
20 claims of the Danco Fill Valve Patents.

21
22 49. Fluidmaster was aware that the Accused Products were not a staple
23 article or commodity of commerce suitable for substantial non-infringing use, and
24 had no substantial non-infringing use, in that the Accused Products could only be
25 used in a manner that infringed the Danco Fill Valve Patents.
26
27
28

1 50. When the Accused Products are used by Fluidmaster's distributors and
2 customers, the Accused Products directly infringe at least the above-referenced
3 claims of the Danco Fill Valve Patents, as set forth above.
4

5 51. Accordingly, Fluidmaster has indirectly infringed the Danco Fill
6 Valve Patents by contributing to infringement of the Danco Fill Valve Patents,
7 pursuant to 35 U.S.C. § 271(c).
8

9 52. As a result of Fluidmaster's infringement of the Danco Fill Valve
10 Patents, Danco has been damaged by Fluidmaster's unlawful conduct. Danco is
11 entitled to recover damages pursuant to 28 U.S.C. § 284 adequate to compensate it
12 for Fluidmaster's infringing activities in an amount to be determined at trial, but in
13 no event less than a reasonable royalty.
14

15 53. Fluidmaster's infringement of the Danco Fill Valve Patents has
16 injured and continues to injure Danco and will cause irreparable harm unless
17 Fluidmaster is enjoined from infringing the claims of the Danco Fill Valve Patents.
18 Accordingly, Danco is entitled to temporary, preliminary, and/or permanent
19 injunctive relief against Fluidmaster from further infringement pursuant to 35
20 U.S.C. § 283.
21

22 54. Upon information and belief, Fluidmaster's past and continued
23 infringement of the Danco Fill Valve Patents has been deliberate, willful, which
24
25
26
27
28

1 warrants an award of treble damages and attorneys' fees to Danco pursuant to 28
2 U.S.C. §§ 284 & 285.

3
4 **PRAYER FOR RELIEF**

5 WHEREFORE, Danco prays that this Court enter judgment in favor of
6 Danco and against Fluidmaster as follows:

- 7
8 A. Entry of judgment that Fluidmaster has directly and indirectly
9 infringed the Danco Fill Valve Patents pursuant to 35 U.S.C. §
10 271 (a), (b), and/or (c);
11
12 B. An order that Fluidmaster provide an accounting and pay to
13 Danco damages in an amount adequate to compensate Danco for
14 Fluidmaster's infringement of the Danco Fill Valve Patents,
15 including damages for lost profits, but in no event less than a
16 reasonable royalty, including up to treble damages for willful
17 infringement pursuant to 35 U.S.C. § 284;
18
19 C. An order preliminarily and permanently enjoining Fluidmaster
20 and its respective agents, servants, officers, directors, employees,
21 attorneys, affiliated companies, successors-in-interest, and all
22 those in active concert or participation with it, and all other
23 parties properly enjoined by law, from infringing directly or
24 indirectly, inducing others to directly infringe, and/or
25
26
27
28

1 contributing to the infringement of the claims of the Danco Fill
2 Valve Patents;

3 D. An order that this is an exceptional case under 35 U.S.C. § 285
4 meriting that Danco be awarded its costs, including its reasonable
5 attorneys’ fees and other expenses incurred in connection with
6 this action; and,
7
8

9 E. Any other relief that the Court finds legal, just and equitable, as
10 may be available under law or equity, and which the Court finds
11 proper.
12

13 **DEMAND FOR TRIAL BY JURY**

14
15 Danco demands trial by jury of all issues so triable, pursuant to Rule 38 of
16 the Federal Rules of Civil Procedure.

17 Respectfully submitted,

18
19 Dated: June 28, 2023

20 /s/ J. Mark Holland
21 Eric G. Maurer (GA Bar # 478199)
22 (pro hac vice forthcoming)
23 Cynthia J. Lee (GA Bar # 442999)
24 (pro hac vice forthcoming)
25 **THOMAS | HORSTEMEYER, LLP**

26 J. Mark Holland
27 **J. MARK HOLLAND & ASSOCIATES**
28 *Counsel for Plaintiff Danco, Inc.*

\\BIG19\z\Winword\LANCO\L4110\PLEADING\Complaint - Related\2023-06-28-As_Filed\2023-06-28_Complaint_THrev5_Final.docx

EXHIBIT A
Danco's '993 Patent

1
2
3
4
5
6
7
8
9
10
11
12
13
14
15
16
17
18
19
20
21
22
23
24
25
26
27
28



(12) **United States Patent**
Schuster et al.

(10) **Patent No.:** **US 9,139,993 B1**
(45) **Date of Patent:** ***Sep. 22, 2015**

(54) **TOILET FILL VALVE**

(56) **References Cited**

(71) Applicant: **Danco, Inc.**, Irving, TX (US)

U.S. PATENT DOCUMENTS

(72) Inventors: **Michael J. Schuster**, Shorewood, IL (US); **Larry Schneider**, Wadsworth, IL (US)

136,128 A	2/1873	Bralley
994,746 A	6/1911	Dwyer
996,743 A	7/1911	Yancey
1,113,057 A	10/1914	Schumann
1,787,601 A	1/1931	Swanberg
2,087,503 A	7/1937	Clenmons
2,465,866 A	3/1949	Gaines
2,512,176 A	6/1950	Shaffer
2,736,037 A	2/1956	Hardie
2,791,235 A	5/1957	Smith
2,799,865 A	7/1957	Schuster
3,040,769 A	6/1962	Lamb
3,086,546 A	4/1963	Brown

(73) Assignee: **Danco, Inc.**, Irving, TX (US)

(*) Notice: Subject to any disclaimer, the term of this patent is extended or adjusted under 35 U.S.C. 154(b) by 0 days.
This patent is subject to a terminal disclaimer.

(Continued)

(21) Appl. No.: **14/164,424**

OTHER PUBLICATIONS

(22) Filed: **Jan. 27, 2014**

US Patent 6,823,889, File History, 2004-2005 Great-Great-Grand-parent Patent to this Application (copy not attached).

Related U.S. Application Data

(Continued)

(63) Continuation of application No. 13/346,355, filed on Jan. 9, 2012, now Pat. No. 8,650,671, which is a continuation of application No. 12/786,904, filed on May 25, 2010, now Pat. No. 8,104,105, which is a continuation of application No. 10/958,797, filed on Oct. 5, 2004, now Pat. No. 7,743,436, which is a continuation-in-part of application No. 10/798,606, filed on Mar. 11, 2004, now Pat. No. 6,823,889.

Primary Examiner — Tuan N Nguyen

(74) Attorney, Agent, or Firm — Thomas | Horstemeyer, LLP

(51) **Int. Cl.**
E03D 1/00 (2006.01)
E03D 1/32 (2006.01)

(57) **ABSTRACT**

In various embodiments, a water inlet of a toilet fill valve receives water from a water supply. A tank water outlet of the toilet fill valve provides a first portion of the water to a toilet tank. A bowl fill outlet port of the toilet fill valve provides a second portion of the water to a bowl fill restriction that is in direct contact with an extended portion of the toilet fill valve. The bowl fill restriction restricts the flow of the second portion of the water. The bowl fill restriction provides the second portion of the water to a tube that is in direct contact with the bowl fill restriction. The tube provides the second portion of the water to a toilet tank overflow tube.

(52) **U.S. Cl.**
CPC **E03D 1/32** (2013.01)

(58) **Field of Classification Search**
CPC E03D 1/32
USPC 4/331, 324, 366, 415, 675; 285/91; 137/15.26, 432, 434, 436, 437, 137/441-444

See application file for complete search history.

20 Claims, 9 Drawing Sheets

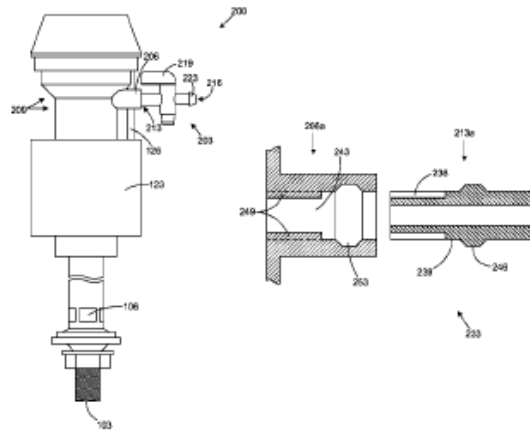

1
2
3
4
5
6
7
8
9
10
11
12
13
14
15
16
17
18
19
20
21
22
23
24
25
26
27
28

US 9,139,993 B1

Page 2

(56)

References Cited

U.S. PATENT DOCUMENTS

3,172,128 A 3/1965 Ducey
 3,321,972 A 5/1967 Goldtrap
 3,457,947 A 7/1969 Fitzgerald
 3,744,064 A 7/1973 Preston
 3,762,395 A 10/1973 Taylor
 3,986,216 A 10/1976 Davis et al.
 3,994,628 A 11/1976 Kemper
 4,007,498 A 2/1977 Pearson
 4,017,916 A 4/1977 Pearson
 4,032,822 A 6/1977 Un
 4,090,532 A 5/1978 Story, Jr.
 4,134,164 A 1/1979 Sanmartin Rial
 4,145,775 A 3/1979 Butler
 4,351,071 A 9/1982 Clar
 4,392,260 A 7/1983 Bensen
 4,420,845 A 12/1983 Antunez
 4,505,231 A 3/1985 Syler
 4,527,295 A 7/1985 Lacore
 4,700,413 A 10/1987 Lopez
 4,707,867 A 11/1987 Kawabe et al.
 4,764,996 A 8/1988 Pino
 4,770,388 A 9/1988 Carman
 4,793,588 A 12/1988 Laverty, Jr.
 4,898,124 A 2/1990 Granberg et al.
 4,918,764 A 4/1990 Haselswerdt et al.
 4,980,932 A 1/1991 Stemples
 5,007,452 A 4/1991 Antunez
 5,036,553 A 8/1991 Sanderson
 5,052,060 A 10/1991 Makita et al.
 5,083,323 A 1/1992 Cannan
 5,134,729 A 8/1992 Shaw
 5,228,152 A 7/1993 Fraley
 5,232,011 A 8/1993 Royalty
 5,245,710 A 9/1993 Haselswerdt et al.

5,327,931 A 7/1994 Royalty
 5,362,026 A 11/1994 Kobayashi et al.
 5,432,959 A 7/1995 Ellsworth et al.
 5,442,820 A 8/1995 Becker
 5,469,586 A 11/1995 Tsutsui et al.
 5,542,448 A 8/1996 Campbell et al.
 5,624,073 A 4/1997 Mueller et al.
 5,708,991 A 1/1998 DeMarco
 5,715,860 A 2/1998 Horad
 5,742,951 A 4/1998 Wright et al.
 5,775,366 A 7/1998 Ray
 5,794,279 A 8/1998 Schwartz
 5,862,537 A 1/1999 Osmond
 5,926,868 A 7/1999 Bjerke
 6,047,725 A 4/2000 Gish et al.
 6,202,227 B1 3/2001 Gurowitz
 6,209,576 B1 4/2001 Davis
 6,219,856 B1 4/2001 Alles
 6,263,519 B1 7/2001 Parsons et al.
 6,295,660 B1 10/2001 Schuster
 6,385,788 B1 5/2002 Wasielewski
 6,409,221 B1 6/2002 Robinson et al.
 6,560,790 B2 5/2003 Saar et al.
 6,823,889 B1 11/2004 Schuster
 2002/0092090 A1 7/2002 Johnson
 2002/0162166 A1 11/2002 Saar et al.
 2004/0199989 A1* 10/2004 Trolio 4/427

OTHER PUBLICATIONS

US Patent 7,743,436, File History, 2004-2010 Great-Grandparent Patent to this Application (copy not attached).
 US Patent 8,104,105, File History, (2010-2012) Grandparent to this Application (copy not attached).
 U.S. Appl. No. 13/346,355 File History (2012-2014) Parent to this Application (copy not attached).

* cited by examiner

1
2
3
4
5
6
7
8
9
10
11
12
13
14
15
16
17
18
19
20
21
22
23
24
25
26
27
28

U.S. Patent

Sep. 22, 2015

Sheet 1 of 9

US 9,139,993 B1

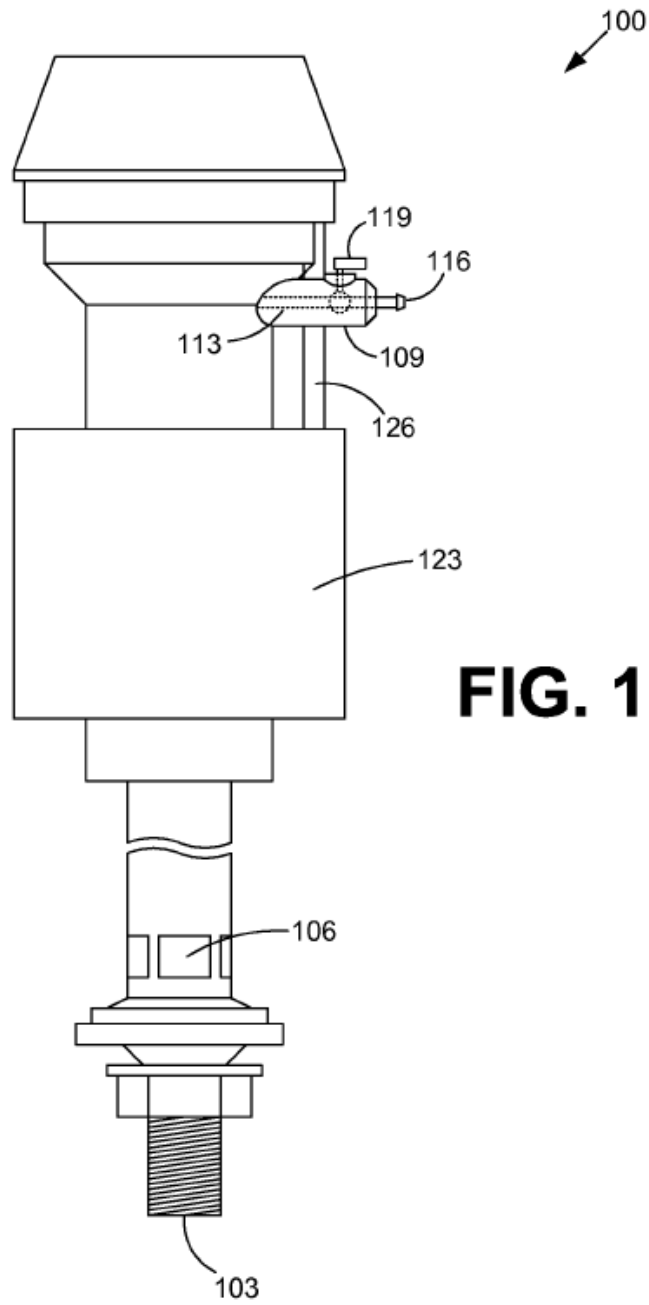

1
2
3
4
5
6
7
8
9
10
11
12
13
14
15
16
17
18
19
20
21
22
23
24
25
26
27
28

U.S. Patent

Sep. 22, 2015

Sheet 2 of 9

US 9,139,993 B1

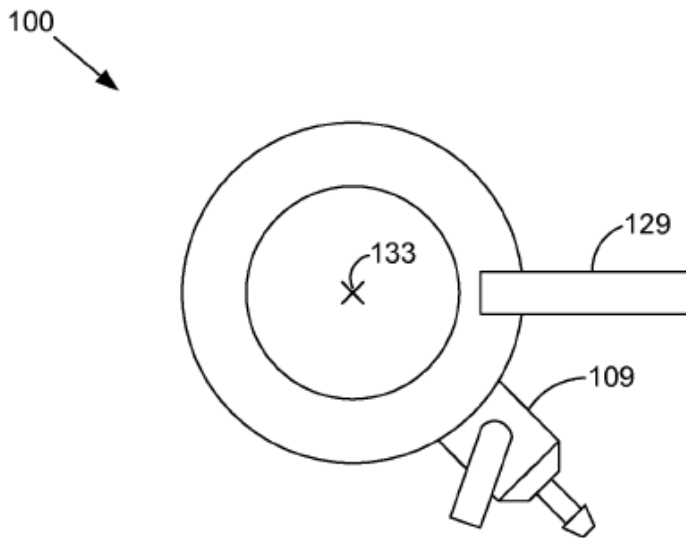

FIG. 2

1
2
3
4
5
6
7
8
9
10
11
12
13
14
15
16
17
18
19
20
21
22
23
24
25
26
27
28

U.S. Patent

Sep. 22, 2015

Sheet 3 of 9

US 9,139,993 B1

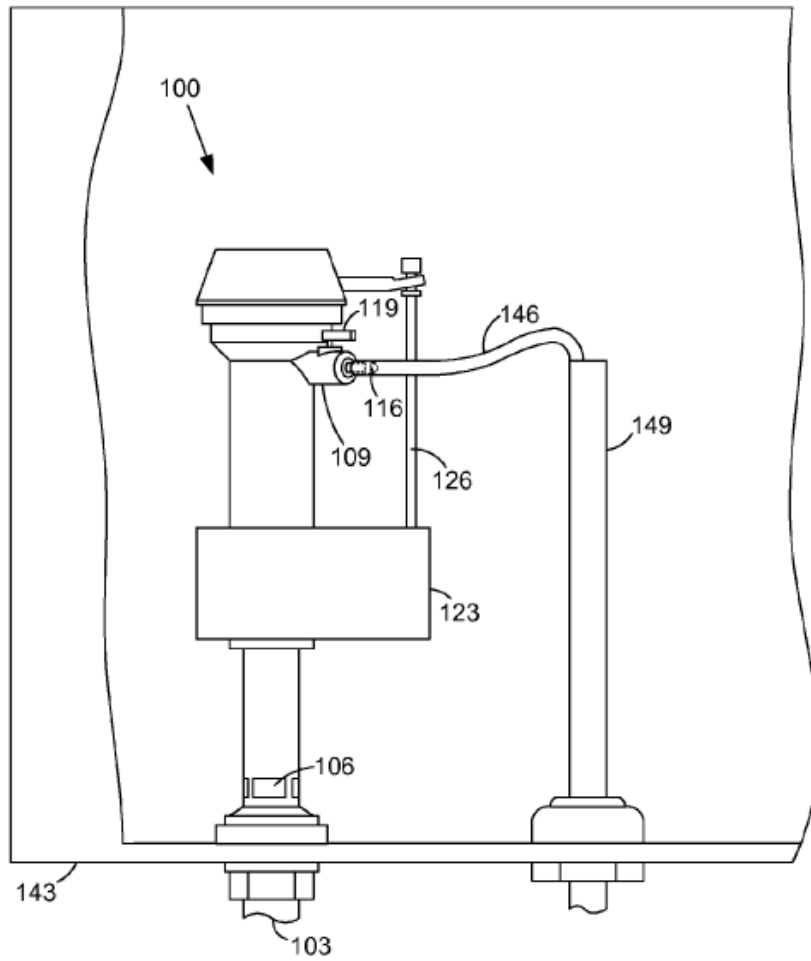

FIG. 3

U.S. Patent

Sep. 22, 2015

Sheet 4 of 9

US 9,139,993 B1

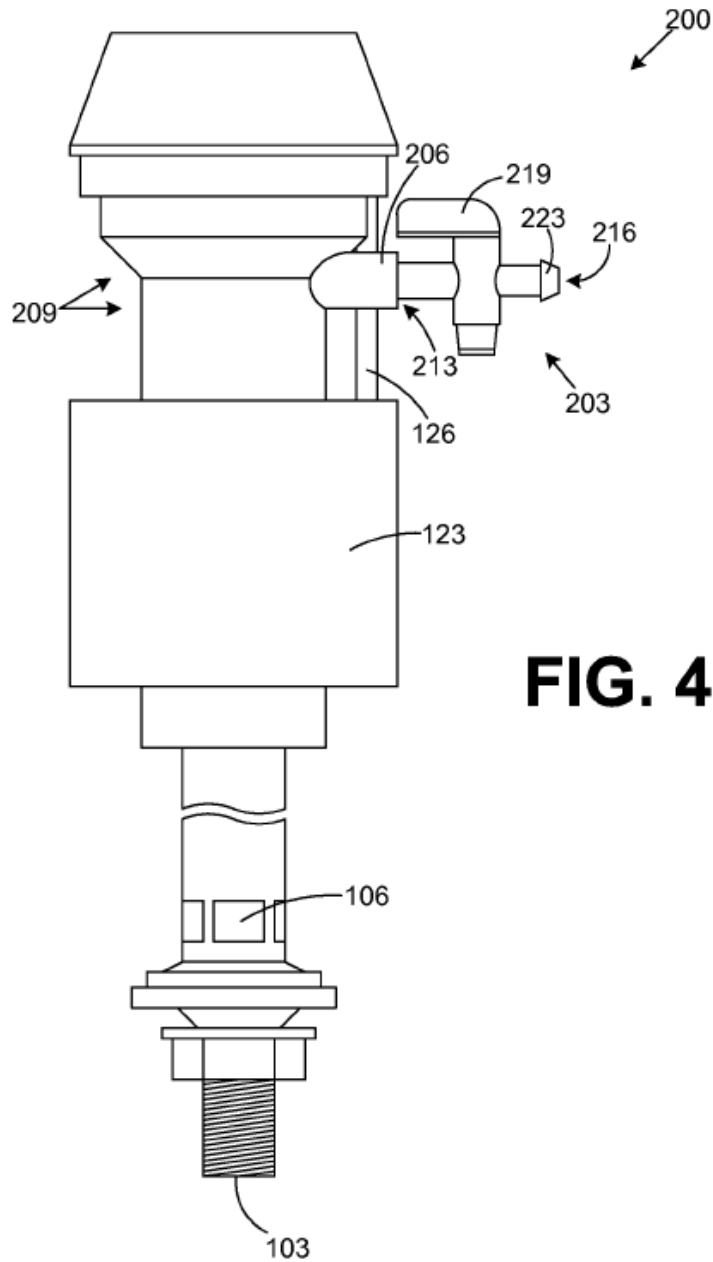

FIG. 4

U.S. Patent

Sep. 22, 2015

Sheet 5 of 9

US 9,139,993 B1

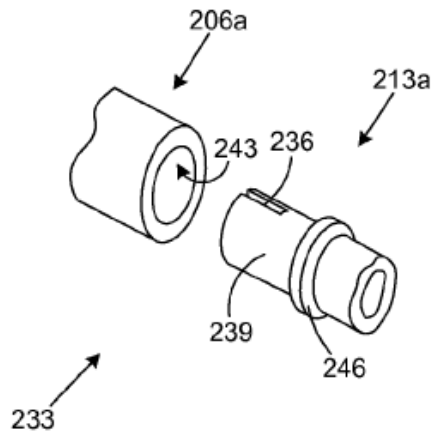

FIG. 5A

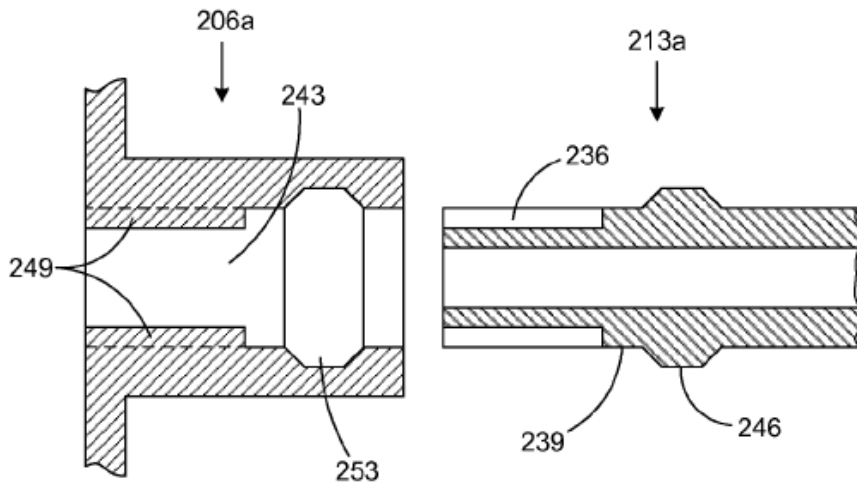

FIG. 5B

U.S. Patent

Sep. 22, 2015

Sheet 6 of 9

US 9,139,993 B1

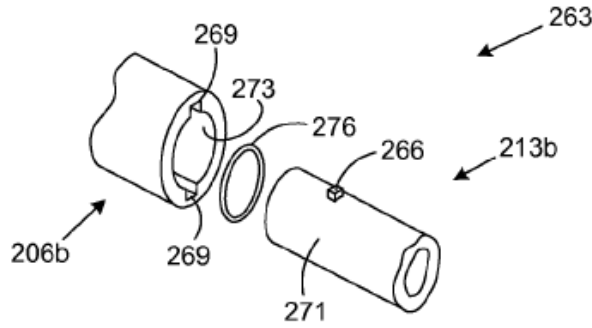

FIG. 6A

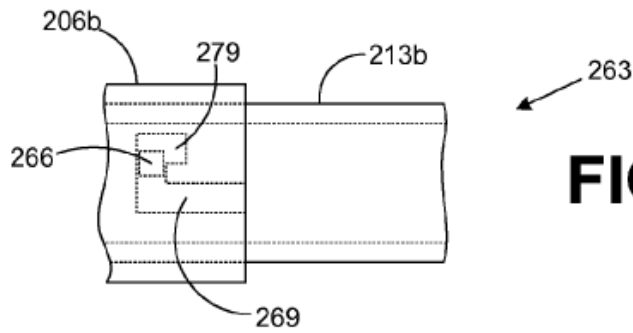

FIG. 6B

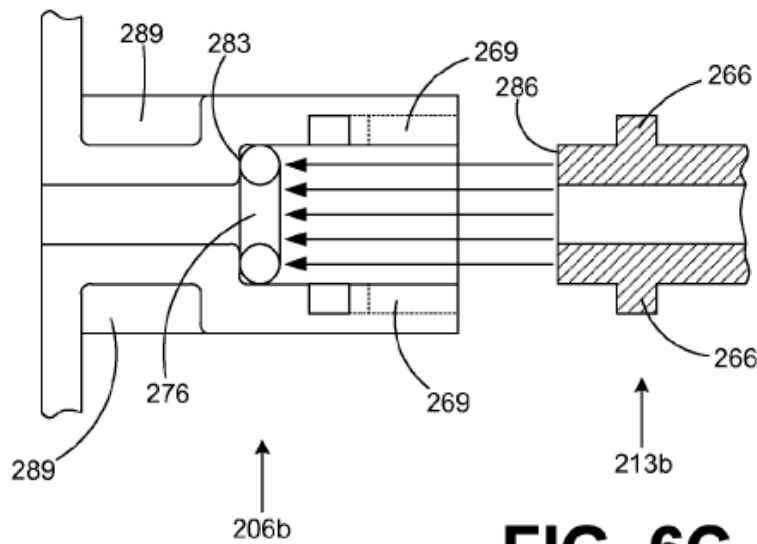

FIG. 6C

1
2
3
4
5
6
7
8
9
10
11
12
13
14
15
16
17
18
19
20
21
22
23
24
25
26
27
28

U.S. Patent

Sep. 22, 2015

Sheet 7 of 9

US 9,139,993 B1

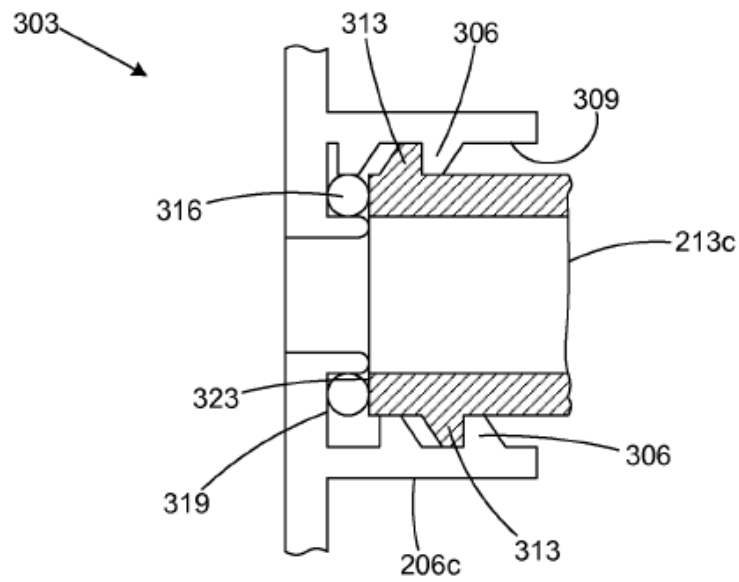

FIG. 7

U.S. Patent

Sep. 22, 2015

Sheet 8 of 9

US 9,139,993 B1

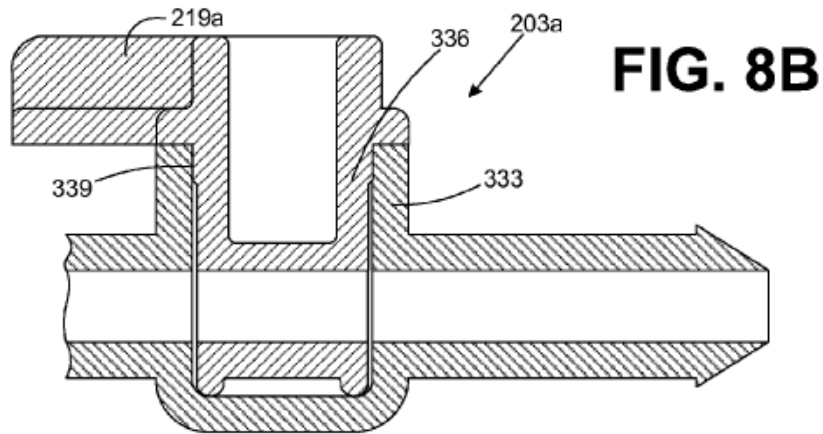
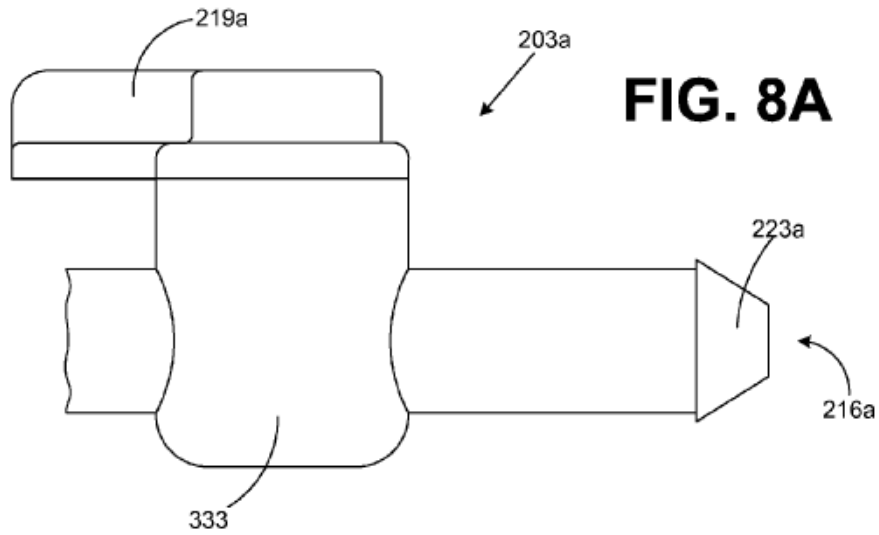

U.S. Patent

Sep. 22, 2015

Sheet 9 of 9

US 9,139,993 B1

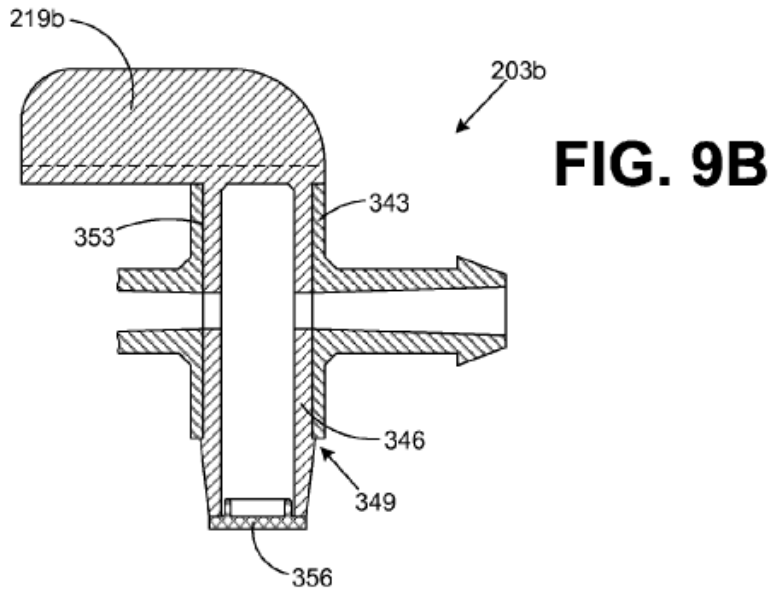
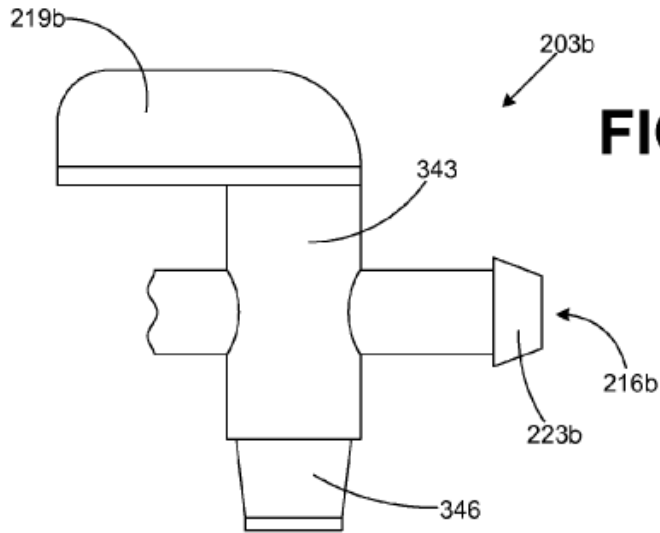

US 9,139,993 B1

1
TOILET FILL VALVE

CROSS REFERENCE TO RELATED APPLICATIONS

The present patent application is a Continuation Application of, and claims priority to, U.S. patent application entitled "Toilet Fill Valve with Adjustable Bowl Fill Flow" filed on Jan. 9, 2012 and assigned Ser. No. 13/346,355, which is a Continuation Application of, and claims priority to, U.S. patent application entitled "Toilet Fill Valve with Adjustable Bowl Fill Flow" filed on May 25, 2010 and assigned Ser. No. 12/786,904, which is a Continuation Application of, and claims priority to, U.S. Pat. No. 7,743,436 entitled "Toilet Fill Valve with Adjustable Bowl Fill Flow" filed on Oct. 5, 2004, which is a Continuation-in-Part Application of, and claims priority to, U.S. Pat. No. 6,823,889 entitled "Toilet Fill Valve with Adjustable Bowl Fill Flow" filed on Mar. 11, 2004.

BACKGROUND

A toilet fill valve in a toilet typically includes a water outlet that provides water for refilling a toilet bowl during a flush cycle. Unfortunately, the water flowing out of such conventional water outlets to fill a toilet bowl provide much more water than is necessary to fill the average toilet bowl. Consequently, much of the water that flows into a toilet bowl during the average flush cycle is lost down the drain. This translates into a loss of millions of gallons of water each year.

BRIEF DESCRIPTION OF THE SEVERAL VIEWS OF THE DRAWINGS

The invention can be understood with reference to the following drawings. The components in the drawings are not necessarily to scale. Also, in the drawings, like reference numerals designate corresponding parts throughout the several views.

FIG. 1 is a drawing of a side view of a toilet fill valve according to an embodiment of the present invention;

FIG. 2 is a drawing of a top view of the toilet fill valve of FIG. 1;

FIG. 3 is a drawing of a cutaway view of a toilet tank within which the toilet fill valve of FIG. 1 is installed;

FIG. 4 is a drawing of a side view of a toilet fill valve according to an embodiment of the present invention;

FIGS. 5A and 5B are drawings that illustrate one example of a coupling of a bowl fill valve to the toilet fill valve of FIG. 4 according to an embodiment of the present invention;

FIGS. 6A, 6B, and 6C are drawings that illustrate another example of a coupling of a bowl fill valve to the toilet fill valve of FIG. 4 according to an embodiment of the present invention;

FIG. 7 is a drawing that illustrates still another example of a coupling of a bowl fill valve to the toilet fill valve of FIG. 4 according to an embodiment of the present invention;

FIGS. 8A and 8B are drawings that illustrate an example of a bowl fill valve that is coupled to the toilet fill valve of FIG. 4 according to an embodiment of the present invention; and

FIGS. 9A and 9B are drawings that illustrate another example of a bowl fill valve that is coupled to the toilet fill valve of FIG. 4 according to an embodiment of the present invention.

DETAILED DESCRIPTION

With reference to FIG. 1, shown is a toilet fill valve 100 according to an embodiment of the present invention. The

2

toilet fill valve 100 includes a water inlet 103 at the bottom of the toilet fill valve 100 that is configured to be coupled to a water source outside of a toilet tank within which the toilet fill valve 100 is installed. The toilet fill valve 100 includes one or more water outlets 106 that are configured to supply water into a toilet tank within which the toilet fill valve 100 is installed. The toilet fill valve 100 may be, for example, a pilot style fill valve. However, it is understood that the toilet fill valve 100 may be any style of fill valve such as, for example, a ballcock valve, etc. The toilet fill valve 100 also includes a bowl fill valve 109 according to an embodiment of the present invention. The bowl fill valve 109 includes a bowl fill valve inlet 113 and a bowl fill valve outlet 116. In addition, the bowl fill valve 109 includes a handle 119 that facilitates a manual adjustment of the bowl fill valve 109.

The bowl fill valve 109 is integral with the toilet fill valve 100. In this respect, the term "integral" refers to the fact that the bowl fill valve 109 and the toilet fill valve 100 comprise a single structure. In this respect, the bowl fill valve 109 may be included within the body of the toilet fill valve 100 as a portion of the toilet fill valve 100 in a single piece construction. Specifically, the bowl fill valve 109 may be molded as a portion of the toilet fill valve 100 or it may be snapped or clamped into place, or it may be attached to the toilet fill valve 100 in some other manner, etc.

Within the toilet fill valve 100, the bowl fill valve inlet 113 is operatively coupled to the water inlet 103. In this respect, when the toilet fill valve 100 is open and water flows from the water inlet 103 to the water outlets 106 and into a toilet tank, an amount of water is also supplied to the bowl fill valve inlet 113 that flows through the bowl fill valve 109 and out the bowl fill valve outlet 116. By virtue of the manual setting of the handle 119 of the bowl fill valve 109, the flow of water through the bowl fill valve 109 is regulated. In this manner, the flow of water is regulated so that enough water flows out of the bowl fill valve 109 to fill a toilet bowl without wasting any water down a drain.

Thus, the bowl fill valve 109 is configured to supply an adjustable flow of water out of the bowl fill outlet 116 that is directed to a toilet bowl during a flush cycle of a toilet to fill the toilet bowl. The flow of water is adjusted so that just enough flows out of bowl fill valve 109 so as to fill the toilet bowl without wasting any water.

The toilet fill valve 100 includes a float 123 that is operatively coupled to an actuating arm (not shown) by a translating stem 126. The float 123 floats on the water within a toilet tank and, depending on the location of the float 123 along the toilet fill valve 100, the toilet fill valve 100 is open or closed as can be appreciated by those with ordinary skill in the art. The bowl fill valve 109 and the actuating arm (not shown) are each located on the toilet fill valve 100 so as to prevent any interference between the bowl fill valve 109 and the translational stem 126 or the actuating arm as will be discussed.

According to an embodiment of the present invention, the bowl fill valve 109 may include a number of biased positions. In this respect, the movement of the handle 119 may cause the bowl fill valve 109 to move from one predefined biased position to other predefined biased positions. In this respect, various mechanisms such as tabs, snaps, or other position biasing structures may be employed. The biased positions of the bowl fill valve 109 help ensure that the bowl fill valve 109 remains in a given setting selected by a user by a manual manipulation of the handle 119 during the normal course of operation of the toilet fill valve 100. Thus, by virtue of the biased positions, the bowl fill valve 109 is prevented from moving out of a desired

US 9,139,993 B1

3

4

position set by a user over a long period of use due to vibration and other factors as can be appreciated by those with ordinary skill in the art.

The bowl fill valve 109 may be, for example, a ball valve, a gate valve, a globe valve, a plug valve, a diaphragm valve, a butterfly valve, a needle valve, a sliding gate, a quick turn valve, a knife valve or any other appropriate type of valve as can be appreciated by those with ordinary skill in the art.

To operate the toilet fill valve 100, the toilet fill valve 100 is first installed within a toilet tank. When a toilet is flushed and the tank is drained, the float 123 moves downward along the toilet fill valve 100 and, consequently, the toilet fill valve 100 opens to allow water to flow from the water inlet 103 and out the water outlets 106 into a toilet tank. At the same time, water flows into the bowl fill valve inlet 113 and out the bowl fill valve outlet 116 through the bowl fill valve 109. Based on the setting of the handle 119, the bowl fill valve 109 determines the precise flow rate of the water that flows out the bowl fill valve outlet 116. A tube is typically employed to direct the water flowing out the bowl fill valve outlet 116 to an overflow tube in the toilet tank. In this respect, the water flowing out the bowl fill valve outlet 116 refills the toilet bowl of the respective toilet.

Referring next to FIG. 2, shown is a top view of the toilet fill valve 100 according to an embodiment of the present invention. In this respect, the actuating arm 129 of the bowl fill valve 100 is seen with respect to the bowl fill valve 109. The actuating arm 129 is coupled to the float by way of the translational stem 126 (FIG. 1). In this respect, the actuating arm 129 extends in an orthogonal direction relative to a longitudinal axis 133 of the toilet fill valve 100. The longitudinal axis 133 is centered in the toilet fill valve 100 along the length of the toilet fill valve 100. Also, the bowl fill valve 109 extends in an orthogonal direction relative to the longitudinal axis 133 of the toilet fill valve 100. In order to prevent interference between the bowl fill valve 109 and the translational stem 126 or the actuating arm 129, the actuating arm 129 is angularly offset relative to the bowl fill valve 109 as shown. In this respect, the translational stem 126 is coupled to the free end of the actuating arm 129. By virtue of the angular offset between the bowl fill valve 109 and the actuating arm 129, the operation of the bowl fill valve 109 does not interfere with the operation of the toilet fill valve 100 itself by virtue of the fact that the float 123 (FIG. 1) can move freely with the movement of the translational stem 126 in order for proper operation of the toilet fill valve 100.

With reference to FIG. 3, shown is the toilet fill valve 100 as installed within a toilet tank 143 according to an embodiment of the present invention. In this respect, the toilet fill valve 100 includes the water inlet 103 that is coupled to a water source outside of the toilet tank 143. The toilet fill valve 100 also includes one or more water outlets 106 that direct a flow of water into the toilet tank 143 during the operation of a flush cycle. The bowl fill valve 109 includes the bowl fill valve inlet (not shown) and the bowl fill valve outlet 116, where the bowl fill valve inlet is operatively coupled to the water inlet 103 as described above. Also, the bowl fill valve 109 is integrated with the body of the toilet fill valve 100 as described above.

A tube 146 is coupled to the bowl fill valve outlet 116 and is directed into the overflow tube 149 of the toilet tank 143. The tube 146 directs water that flows out of the bowl fill valve outlet 116 into the overflow tube 149 and refills the toilet bowl associated with the toilet tank 143 as can be appreciated by those with ordinary skill in the art. The bowl fill valve 109 is configured to supply the adjustable flow of water out the bowl fill valve outlet through the tube 146 and into the overflow

tube 149 for filling the toilet bowl during the flush cycle of the toilet. In this respect, no pressure is seen within the tube 146. Specifically, the fact that the bowl fill valve 109 is integral with the toilet fill valve 100 prevents the creation of a pressure head in the tube 146 as would be the case if the bowl fill valve 109 were included in the middle of the tube 146. The fact that a pressure head is not created in any portion of the tube 146 prevents the tube 146 from working its way off of the bowl fill valve outlet 116 over time.

When installed, the bowl fill valve 109 is calibrated for the particular flush cycle of the toilet within which the toilet fill valve 100 is installed. To calibrate the bowl fill valve 109, a user first determines the water level in the toilet bowl when the toilet bowl is full of water. This gives the user a starting and an ending point for determining when the toilet bowl of the respective toilet is full. Next, the bowl fill valve handle 109 is adjusted so that the bowl fill valve 109 is placed in a predefined position that allows a predefined flow of water to refill the toilet bowl. In this manner, one adjusts the actual flow of water that refills the toilet bowl. Thereafter, the user flushes the toilet itself. Next, the user determines if the flow of water into the toilet bowl by virtue of the adjustments made to the bowl fill valve 109 is adequate to refill the toilet bowl during the flush cycle. This may be determined, by identifying whether the level of the water in the toilet bowl reaches the full level determined at the beginning of the bowl fill valve calibration above.

The flow of water from the bowl fill valve 109 should be set so as to ensure that the water level in the toilet bowl reaches the full level at about the same time that the flush cycle ends. In other words, the level of water in the toilet bowl should reach its highest level at the same time that the flush cycle ends. This prevents any water from being lost down the drain associated with the toilet.

If the amount of water that flows into the toilet bowl is inadequate to refill the toilet bowl during the flush cycle as described above, then one should repeat the steps of adjusting the bowl fill valve, flushing the toilet, and then once again determining if the flow of water into the toilet bowl is adequate to refill the toilet bowl during a flush cycle.

Ultimately, during use of the toilet that includes the toilet fill valve 100 and the toilet tank 143, a user flushes the toilet and a predetermined flow of water exits the bowl fill valve outlet 116 and is directed into the toilet bowl. After the toilet tank has drained during the flush cycle, a flapper closes in the toilet tank and the toilet tank refills. During the refilling of the tank, the water supplied by the bowl fill valve 109 fills the toilet bowl itself. The amount of water supplied by the bowl fill valve in the time it takes to refill the toilet tank should be approximately equal to the amount of water needed to fill the toilet bowl. By virtue of the fact that the bowl fill valve 100 is integrated within the toilet fill valve 100, a pressure head is prevented from being created due to any potential pinching of the tube 146 or other similar adjustment mechanism.

With reference to FIG. 4, shown is a toilet fill valve 200 according to another embodiment of the present invention. The toilet fill valve 200 includes the same water inlet 103 and the water outlets 106 as the toilet fill valve 100 (FIG. 1). The toilet fill valve 200 also includes the float 123 and the translational stem 126 as was described with reference to the toilet fill valve 100. In addition, the toilet fill valve 200 includes a bowl fill valve 203 that is integral with the toilet fill valve 200 as will be described. As stated above, the term "integral" refers to the fact that the bowl fill valve 200 and the toilet fill valve 100 comprise a single structure. In this embodiment, the

US 9,139,993 B1

5

bowl fill valve **200** is a separate component that is attached to the body of the toilet fill valve **100**, thereby forming the integral, single structure.

The toilet fill valve **200** also includes a bowl fill outlet port **206** that radially extends from a portion of a body **209** of the toilet fill valve **200**. In this respect, the bowl fill outlet port is operatively coupled to the water inlet **103**. In particular, when the toilet fill valve **200** is in an "on" state, water that flows in the water inlet **103** flows out of both the water outlets **106** and the bowl fill outlet port **206**. The water flowing out of the bowl fill outlet port **206** flows through the bowl fill valve **203** as will be described.

The bowl fill valve **203** includes a bowl fill valve inlet port **213** and a bowl fill valve outlet port **216**. The bowl fill valve inlet port **213** is compatible with the bowl fill outlet port **206**, where the bowl fill valve inlet port **213** is coupled to the bowl fill outlet port **206** when the bowl fill valve **203** is coupled or affixed to the toilet fill valve **200**. The bowl fill valve inlet port **213** is compatible with the bowl fill outlet port **206** in the sense that both the bowl fill valve inlet port **213** and the bowl fill outlet port **206** comprise various structures that couple together when the bowl fill valve **203** is connected to the bowl fill outlet port **206** as will be described. In particular, various embodiments of the coupling between the bowl fill valve inlet port **213** and the bowl fill outlet port **206** are described herein.

The bowl fill valve **203** also includes a handle that may be adjusted by hand to adjust a flow of water through the bowl fill valve **203** during a flush operation of a toilet in which the toilet fill valve **200** is installed. Typically, the handle **219** is initially adjusted to a desired position when the toilet fill valve **200** is installed and generally remains in such position for the continued operation of the toilet fill valve **200**. During the life cycle of the bowl fill valve **203**, it may be possible that the bowl fill valve **203** is adjusted to take into account various changes in the operation of the toilet fill valve **200** such as, for example, changes in pressure or other operational changes.

The bowl fill valve **203** also includes a nipple **223**. The nipple **223** is adapted to mate with a tube that extends from the bowl fill valve outlet port **216** to the overflow tube **149** (FIG. 3) in a manner similar to that as shown in FIG. 3 with respect to the tube **146** (FIG. 3) that extends from the nipple **116** (FIG. 3) to the overflow tube **149** (FIG. 3). The bowl fill valve **203** extends beyond the bowl fill outlet port **206** in a radial direction with respect to the portion of the body **209** of the toilet fill valve **200**.

In some embodiments, the bowl fill outlet port **206** may comprise a female receptacle and, correspondingly, the bowl fill valve inlet port **213** may comprise a male end compatible with the female receptacle. Alternatively, the bowl fill valve inlet port **213** may comprise a female receptacle and the bowl fill outlet port **206** may comprise a male end compatible with such female receptacle.

The toilet fill valve **200** further includes an actuating arm (not shown) that extends in a radial direction that is orthogonal relative to a longitudinal axis of the toilet fill valve **200** in a manner similar as that described with reference to the toilet fill valve **100** (FIG. 1). The longitudinal axis is defined as an axis that runs from the water inlet **103** through the body **209** of the toilet fill valve **200** and out the top of the toilet fill valve **200**. In one embodiment, the bowl fill valve **203** extends radially in an orthogonal direction relative to such longitudinal axis of the toilet fill valve **200**. Also, in one embodiment, the actuating arm is angularly offset relative to the bowl fill valve **203** to prevent interference between the bowl fill valve **203** and the translational stem **126** that extends from the float **123** to a free end of the actuating arm. This allows the float

6

123 to move up and down and to engage the actuating arm during the normal operation of the toilet fill valve **200** during various flush cycles.

In addition, the bowl fill valve **203** may be constructed with a number of biased positions that help prevent the bowl fill valve **203** from moving out of adjustment over time when the force of pressure develops therein. Also, the biased positions aid a user in actual adjustment of the bowl fill valve **203** as can be appreciated.

The toilet fill valve **200** provides an advantage in that the body **209** of the toilet fill valve **200** may be constructed with the bowl fill outlet port **206** using a molding process that is much less complex than attempting to mold the entire bowl fill valve **203** within the structure of the body **209** as a single molded construction as was described with reference to one embodiment of the toilet fill valve **100**. In this regard, the bowl fill valve **203** may be constructed as a separate component to the body **209** of the toilet fill valve **200** and assembled for distribution to end users.

Due to the fact that the bowl fill valve **203** is affixed to the toilet fill valve **200** through the coupling of the bowl fill outlet port **206** with the bowl fill valve inlet port **213**, then a pressure head that develops within the bowl fill valve **203** due to the adjustment of the handle **219** during operation of the toilet fill valve **200** will not cause the bowl fill valve **203** to fall off of the toilet fill valve **200**. Thus, when the toilet fill valve **200** is installed in a toilet tank **143**, a user may adjust the opening of the bowl fill valve **203** by adjusting the handle **219** until a desired flow of water flows out of the bowl fill valve outlet port **216** into a tube and into the overflow tube **149** of a toilet. This flow of water is typically established to refill a toilet bowl of a toilet. In this regard, the flow of the water into the overflow tube **149** that refills the toilet bowl during a toilet flush operation may be regulated or adjusted so as to minimize or eliminate the amount of water that is lost down the drain of a toilet due to over filling of the toilet bowl during a flush cycle of a toilet. In one embodiment, the bowl fill valve **203** is adjusted until the filling of the toilet bowl of the toilet coincides with the end of the flush cycle, thereby resulting in little or no loss of water.

Referring next to FIG. 5A, shown is a coupling **233** between one embodiment of the bowl fill outlet port **206**, denoted herein as bowl fill outlet port **206a**, and an embodiment of the bowl fill valve inlet port **213**, denoted herein as bowl fill valve inlet port **213a**. The bowl fill valve inlet port **213a** includes a slot **236** in a side wall **239**. The bowl fill outlet port **206a** comprises a rib (not shown) that extends from a side wall **243** that is inserted into the slot **236** when the bowl fill inlet port **213a** is inserted into the bowl fill outlet port **206a**. The mating of the slot **236** with the rib prevents the rotation of the bowl fill valve **213a** with respect to the bowl fill outlet port **206a** when the bowl fill valve inlet port **213a** is inserted into the bowl fill outlet port **206a**. Alternatively, there may be a number of slots **236** in the side wall **239** of the bowl fill valve inlet port **213a** and a corresponding number of ribs extending from the side wall **243** of the bowl fill outlet port **206a**.

The bowl fill valve inlet port **213a** also includes an annular protrusion **246** that extends from the side wall **239** of the bowl fill valve inlet port **213a**. Correspondingly, an annular groove (not shown) in the side wall **243** of the bowl fill valve outlet port **206a** is provided that mates up with the annular protrusion **246** when the bowl fill valve inlet port **213** is inserted into the bowl fill outlet port **206a**. In this respect, the annular protrusion **246** is snap fit into the annular groove (not shown), thereby affixing the bowl fill valve **203a** to the bowl fill valve outlet port **206a**.

US 9,139,993 B1

7

Turning then to FIG. 5B, shown is a cutaway view of the coupling 233 between the bowl fill outlet port 206a and the bowl fill valve inlet port 213a according to an embodiment of the present invention. In this respect, the bowl fill outlet port 206a is depicted with two ribs 249 extending from the side wall 243 within the bowl fill outlet port 206a. Also, the bowl fill outlet port 206a includes the annular groove 253 into which the annular protrusion 246 snaps when the bowl fill valve inlet port 213a is inserted into the bowl fill outlet port 206a. In this respect, the mating of the annular protrusion 246 with the annular groove 253 fixes the bowl fill valve 203 to the bowl fill outlet port 206a. In this respect, the bowl fill valve 203 becomes an integral portion of the toilet fill valve 200.

Also, the fit between the annular protrusion 246 is a snug fit that forms a seal between the bowl fill outlet port 206a and the bowl fill valve inlet port 213a that prevents the leakage of water from the coupling 233 during a flush cycle. Alternatively, a snug fit may occur between other mating surfaces of the bowl fill outlet port 206a and the bowl fill valve inlet port 213a that prevents leakage of water from the coupling 233.

With reference to FIGS. 5A and 5B, even though the slots 236 are depicted as being formed within the side wall 239 of the bowl fill valve inlet port 213 and the ribs 249 extend from the side wall 243 within the bowl fill outlet port 206, it is possible that this arrangement may be reversed where the slots 236 are formed in the side wall 243 of the bowl fill outlet port 206a and the ribs 249 extend from the side wall 239 of the bowl fill valve inlet port 213a. In addition, the annular groove 253 may be created in the side wall 239 of the bowl fill valve inlet port 213 and the annular projection 246 may extend inward from the side wall 243 within the bowl fill outlet port 206 in a reverse arrangement than that shown with reference to FIG. 5B.

Referring next to FIGS. 6A, 6B, and 6C, shown is a coupling 263 between another embodiment of the bowl fill outlet port 206, denoted herein as bowl fill outlet port 206b, and another embodiment of the bowl fill valve inlet port 213, denoted herein as bowl fill valve inlet port 213b. The bowl fill valve inlet port 213b includes at least two locking ears 266 that mate with corresponding locking grooves 269 in the bowl fill outlet port 206b. In particular, the locking ears 266 extend from a side wall 271 of the bowl fill valve inlet port 213b. The locking grooves 269 are disposed in the side wall 273 of the bowl fill outlet port 206b. When the bowl fill valve 203 is inserted and twisted into the bowl fill outlet port 206b, each of the locking ears 266 is situated in a locking position of one of the locking grooves 269 as will be described. The coupling 263 further comprises a sealing ring 276 that may be, for example, a rubber O-ring or other type of sealing ring. The sealing ring 276 is compressed between an end of the bowl fill valve inlet port 213b and a seat within the bowl fill outlet port 206b as we described. While at least two locking ears 266 and corresponding locking grooves 269 are shown, it is possible that a design may be employed that comprises a single locking ear 266 and a single corresponding locking groove 269.

With reference to FIG. 6B, shown is a portion of the bowl fill valve inlet port 213b and the bowl fill outlet port 206b as the bowl fill valve inlet port 213b is inserted into the bowl fill outlet port 206b and is partially rotated such that the locking ears 266 are almost located in the locking positions 279. In this respect, each of the locking grooves 269 is a "J" formation. The J formation of the locking grooves 269 allows the locking ears 266 to slide down and around the partial loop of the J and seat in the locking position 279 such that the sealing ring 276 exerts a force against the end of the bowl fill valve inlet port 213b, thereby pushing the locking ears 266 into the locking positions 279 of the locking grooves 269 and holding

8

the locking ears 266 in place. This ensures that the bowl fill valve 203 remains coupled to the bowl fill outlet port 206b.

With reference to FIG. 6C, shown is a cutaway view of the coupling 263 between the bowl fill outlet port 206b and the bowl fill valve inlet port 213b. In this respect, the bowl fill valve inlet port 213b is inserted into the bowl fill outlet port 206b in a manner such that the locking ears 266 mate with the locking grooves 269. When the locking ears 266 reach the bottom of the "J" of the locking grooves 269, then the bowl fill valve 203 is rotated so that the locking ears 266 may be seated in the locking positions 279.

The sealing ring 276 is seated against a portion of the bowl fill outlet port 206b. In one embodiment, this portion is a seating face 283 of the bowl fill outlet port 206b. Also, a portion of the bowl fill valve inlet port 213b is mated against the sealing ring 276. In one embodiment, this portion of the bowl fill valve inlet port 213b is an end face 286 such that the sealing ring is clamped between the seating face 283 and the end face 286 when the bowl fill valve inlet port 213b is inserted fully into the bowl fill outlet port 206b. The clamping or compression of the sealing ring 276 pushes the locking ears 266 into the locking position 279 of the locking grooves 269 once the bowl fill valve 203 is rotated accordingly. In this respect, the compressive force of the sealing ring 276 helps keep the bowl fill valve inlet port 213b of the bowl fill valve 203 mated with the bowl fill outlet port 206b. Also, the sealing ring 276 forms a seal between the bowl fill outlet port 206b and the bowl fill valve inlet port 213b that prevents leakage of water from the coupling 263 between the bowl fill outlet port 206b and the bowl fill valve inlet port 213b.

The locking positions 279 of the locking grooves and the locking ears 266 are located such that when the bowl fill valve 203 is rotated thereby positioning the locking ears 266 in the locking positions 279, the bowl fill valve 203 is substantially upright. In addition, the bowl fill outlet port 206b includes structural ribs 289 that provide greater structural stability for the bowl fill outlet port 206b and its attachment to the portion of the body 209 of the toilet fill valve 200 (FIG. 4). Alternatively, the bowl fill outlet port 206b may be attached without the structural ribs 289. In addition, it may be the case that the locking ears 266 extend inward from the side wall 273 of the bowl fill outlet port 206b and that the locking grooves 269 be situated within the side wall 271 of the bowl fill valve inlet port 213b.

Referring next to FIG. 7, shown is a cutaway view of a coupling 303 between a third embodiment of the bowl fill outlet port 206, denoted herein as bowl fill outlet port 206c and the bowl fill valve inlet port 213, denoted herein as bowl fill valve inlet port 213c. In this respect, the bowl fill outlet port 206c includes a first thread 306 disposed on a side wall 309 of the bowl fill outlet port 206c. A second thread 313 is disposed on a side wall of the bowl fill valve inlet port 213c that engages the first thread 306 disposed in the side wall of the bowl fill outlet port 206c. The bowl fill valve inlet port 213c is coupled to the bowl fill outlet port 206c by way of the first and second threads 306 and 313. Specifically, the bowl fill valve 203 may be screwed onto the bowl fill outlet port 206c by virtue of the threads 306 and 313. When the bowl fill valve inlet port 213c is screwed into the bowl fill outlet port 206c, a sealing ring 316 is clamped between portions of the bowl fill valve inlet port 213c and the bowl fill outlet port 206c such as a seating face 319 of the bowl fill outlet port 206c and an end face 323 of the bowl fill valve inlet port 213c. In this respect, a seal is formed between the bowl fill outlet port 206c and the bowl fill valve inlet port 213c. Alternatively, the threads 306 and 313 may be specified so as to form an adequate seal between the bowl fill valve outlet port 206c and

1
2
3
4
5
6
7
8
9
10
11
12
13
14
15
16
17
18
19
20
21
22
23
24
25
26
27
28

US 9,139,993 B1

9

the bowl fill valve inlet port 213c for purposes of preventing leakage. As an additional alternative, the seating face 319 and the end face 323 or other portions of the bowl fill valve inlet port 213c and the bowl fill outlet port 206c may be compressed together to form a seal to prevent leakage. Alternatively, the bowl fill outlet port 206c and the bowl fill valve inlet port 213c may be designed to include mating surfaces that perform a friction seal as can be appreciated.

Referring next to FIG. 8a, shown is one embodiment of the bowl fill valve 203, denoted herein as bowl fill valve 203a according to an embodiment of the present invention. The bowl fill valve 203a includes a handle 219a and a valve body 333. The bowl fill valve 203a includes the bowl fill valve outlet port 216a and the bowl fill valve inlet port (not shown) the bowl fill outlet port 216a includes a nipple 223a.

Referring then to FIG. 8b, shown is a cutaway view of the bowl fill valve 203a according to an embodiment of the present invention. In this respect, the valve body 333 forms a cavity within which a valve 336 is inserted as shown. A line contact 339 is formed between surfaces of the valve body 333 and the valve 336 so as to both hold the valve 336 within the cavity that is formed by the valve body 333 and to form a seal between the valve body 333 and the valve 336 to prevent water leakage. As seen, the valve 336 is integrated with the handle 219a in a single piece construction, although multiple piece construction may be employed.

With reference to FIGS. 9a and 9b, shown is a second embodiment of the bowl fill valve 203, denoted herein as bowl fill valve 203b according to an embodiment of the present invention. The bowl fill valve 203b includes a valve body 343 within which is inserted a valve 346. The bowl fill valve 203b further comprises the bowl fill valve outlet port 216b and a bowl fill valve inlet port (not shown). The bowl fill valve outlet port 216b includes a nipple 223b. The bowl fill valve 203b further includes a handle 209b for manual adjustment of the bowl fill valve 203b.

Referring next to FIG. 9b, shown is a cutaway view of the bowl fill valve 203b according to an embodiment of the present invention. As shown, the valve 346 is inserted into the valve body 343. A snap fit 349 affixes the valve 346 within the valve body 343. A seal is formed by virtue of an interference fit 353 between a surface of the valve 346 and an inner surface of the valve body 343. The bottom of the cavity within the valve 346 is closed by a cap 356 that may be spin welded onto the valve 346 after the valve is inserted into the valve body 343.

In addition, referring back to FIG. 4, other types of couplings may be employed between the bowl fill outlet port 206 the bowl fill valve inlet port 213. For example, the bowl fill outlet port 206 the bowl fill valve inlet port 213 may be configured to facilitate a compression fitting there between. Also, other snap fit and sealing configurations may be employed beyond those specifically described herein.

Although the invention is shown and described with respect to certain embodiments, it is obvious that equivalents and modifications will occur to others skilled in the art upon the reading and understanding of the specification. The present invention includes all such equivalents and modifications, and is limited only by the scope of the claims.

What is claimed is:

1. A system, comprising:

a toilet fill valve that comprises:

a body comprising an extended portion, wherein the extended portion is integrally molded with the body, wherein the extended portion forms a bowl fill outlet port;

10

a water inlet configured to receive water from a water source; and

a tank water outlet configured to provide a first portion of the water to a toilet tank during at least a portion of a flush cycle;

a water flow regulator configured to attach directly to the extended portion of the body, wherein a portion of the water flow regulator is configured to insert into, and come into contact with, the extended portion of the body, wherein the water flow regulator is configured to receive a second portion of the water from the bowl fill outlet port during at least a portion of the flush cycle, wherein the water flow regulator is configured to constrict a flow rate of the second portion of the water that flows through the water flow regulator; and

a tube that is configured to attach directly to the water flow regulator, wherein the tube is configured to direct the second portion of the water from the water flow regulator directly to a toilet tank overflow tube.

2. The system of claim 1, wherein the extended portion of the body extends radially from a longitudinal axis of the toilet fill valve.

3. The system of claim 1, wherein the water flow regulator is configured to be clamped to the toilet fill valve.

4. The system of claim 1, wherein the water flow regulator is configured to be snapped onto the toilet fill valve.

5. The system of claim 1, wherein the toilet fill valve further comprises:

a float; and

an actuating arm coupled to the float, wherein the actuating arm extends radially relative to a longitudinal axis of the toilet fill valve, wherein the actuating arm is angularly offset relative to the bowl fill valve, thereby preventing an interference with the water flow regulator and a translational stem that extends from the float to a free end of the actuating arm.

6. The system of claim 1, wherein the water flow regulator further comprises a nipple that is configured to insert into the tube.

7. The system of claim 1, wherein the water flow regulator prevents a pressure head from being formed in the tube.

8. A method, comprising:

receiving, via a water inlet of a toilet fill valve, water from a water supply;

providing, via a tank water outlet of the toilet fill valve, a first portion of the water to a toilet tank;

providing, via a bowl fill outlet port of the toilet fill valve, a second portion of the water to a water flow regulator, wherein an extended portion of the toilet fill valve forms the bowl fill outlet port, wherein the extended portion is integrally molded with the toilet fill valve, wherein the water flow regulator is in contact with the extended portion of the toilet fill valve, wherein a portion of the water flow regulator inserts into the extended portion of the toilet fill valve and comes into contact with the extended portion of the toilet fill valve;

restricting, using the water flow regulator, a flow of the second portion of the water;

providing, via the water flow regulator, the second portion of the water to a tube that is in contact with the water flow regulator; and

providing, via the tube, the second portion of the water to a toilet tank overflow tube.

9. The method of claim 8, wherein the water flow regulator prevents a pressure head from being formed in the tube.

1
2
3
4
5
6
7
8
9
10
11
12
13
14
15
16
17
18
19
20
21
22
23
24
25
26
27
28

US 9,139,993 B1

11

10. The method of claim 8, further comprising terminating, using the toilet fill valve, the flow of the second portion of the water so that a water level in a toilet bowl is at a predefined level.

11. The method of claim 10, wherein the water level is determined at least in part by the water flow regulator.

12. The method of claim 8, wherein the extended portion of the toilet fill valve is a portion of a body of the toilet fill valve.

13. The method of claim 8, wherein the extended portion of the toilet fill valve extends radially from a longitudinal axis of the toilet fill valve.

14. A method, comprising:
inserting a portion of a water flow regulator into an extended portion of a body of a toilet fill valve, the portion of the water flow regulator coming into contact with the extended portion of the body of the toilet fill valve, wherein the extended portion is integrally molded with the body, wherein the extended portion forms a bowl fill outlet port, wherein the water flow regulator is configured to constrict a flow rate of water that flows out of the bowl fill outlet port; and
attaching a tube directly to the water flow regulator, wherein the tube is configured to direct the water from the water flow regulator directly to a toilet tank overflow tube.

12

15. The method of claim 14, further comprising preventing the water flow regulator from detaching from the extended portion of the body.

16. The method of claim 15, wherein preventing the water flow regulator from detaching from the extended portion further comprises clamping the water flow regulator to the extended portion.

17. The method of claim 15, wherein preventing the water flow regulator from detaching from the extended portion further comprises snapping the bowl fill restriction to the extended portion.

18. The method of claim 15, wherein preventing the water flow regulator from detaching from the extended portion further comprises rotating the water flow regulator relative to the extended portion.

19. The system of claim 1, wherein the water flow regulator comprises an adjustable water flow regulator that is configured to adjust the flow rate of the second portion of the water based at least in part on a setting of the adjustable water flow regulator.

20. The method of claim 14, wherein the water flow regulator comprises an adjustable water flow regulator that is configured to adjust the flow rate of the water based at least in part on a setting of the adjustable water flow regulator.

* * * * *

EXHIBIT B
Danco's '105 Patent

1
2
3
4
5
6
7
8
9
10
11
12
13
14
15
16
17
18
19
20
21
22
23
24
25
26
27
28



(12) **United States Patent**
Schuster et al.

(10) **Patent No.:** **US 9,103,105 B1**
(45) **Date of Patent:** ***Aug. 11, 2015**

(54) **TOILET FILL VALVE**

137/441-444

See application file for complete search history.

(71) Applicant: **Danco, Inc.**, Irving, TX (US)

(72) Inventors: **Michael J. Schuster**, Shorewood, IL (US); **Larry Schneider**, Wadsworth, IL (US)

(73) Assignee: **Danco, Inc.**, Irving, TX (US)

(*) Notice: Subject to any disclaimer, the term of this patent is extended or adjusted under 35 U.S.C. 154(b) by 0 days.

This patent is subject to a terminal disclaimer.

(21) Appl. No.: **14/457,697**

(22) Filed: **Aug. 12, 2014**

Related U.S. Application Data

(63) Continuation of application No. 14/164,424, filed on Jan. 27, 2014, which is a continuation of application No. 13/346,355, filed on Jan. 9, 2012, now Pat. No. 8,650,671, which is a continuation of application No. 12/786,904, filed on May 25, 2010, now Pat. No. 8,104,105, which is a continuation of application No. 10/958,797, filed on Oct. 5, 2004, now Pat. No. 7,743,436, which is a continuation-in-part of application No. 10/798,606, filed on Mar. 11, 2004, now Pat. No. 6,823,889.

(51) **Int. Cl.**
E03D 1/00 (2006.01)
E03D 1/32 (2006.01)
E03D 1/14 (2006.01)

(52) **U.S. Cl.**
CPC . **E03D 1/32** (2013.01); **E03D 1/141** (2013.01)

(58) **Field of Classification Search**
CPC E03D 1/32
USPC 4/331, 324, 366, 415, 675; 285/91; 137/15.26, 432, 434, 436, 437,

(56) **References Cited**

U.S. PATENT DOCUMENTS

136,128 A	2/1873	Bralley
994,746 A	6/1911	Dwyer et al.
996,743 A	7/1911	Yancey
1,113,057 A	10/1914	Schumann
1,787,601 A	1/1931	Swanberg
2,087,503 A	7/1937	Clemmons
2,465,866 A	3/1949	Gaines
2,512,176 A	6/1950	Shaffer
2,736,037 A	2/1956	Hardie
2,791,235 A	5/1957	Smith

(Continued)

OTHER PUBLICATIONS

US Patent 6,823,889, File History, 2004-2005 Great-Great-Grand-parent Patent to this Application.

(Continued)

Primary Examiner — Tuan N Nguyen

(74) *Attorney, Agent, or Firm* — Thomas I Horstemeyer, LLP.

(57) **ABSTRACT**

In various embodiments, a water inlet of a toilet fill valve receives water from a water supply. A tank water outlet of the toilet fill valve provides a first portion of the water to a toilet tank. A bowl fill outlet port of the toilet fill valve provides a second portion of the water to a bowl fill restriction that is in direct contact with an extended portion of the toilet fill valve. The bowl fill restriction restricts the flow of the second portion of the water. The bowl fill restriction provides the second portion of the water to a tube that is in direct contact with the bowl fill restriction. The tube provides the second portion of the water to a toilet tank overflow tube.

24 Claims, 9 Drawing Sheets

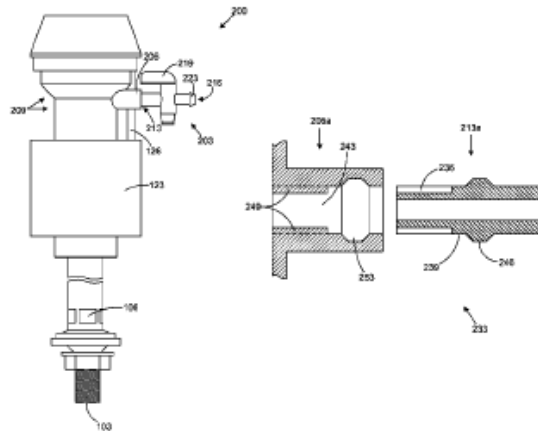

1
2
3
4
5
6
7
8
9
10
11
12
13
14
15
16
17
18
19
20
21
22
23
24
25
26
27
28

US 9,103,105 B1

Page 2

(56)

References Cited

U.S. PATENT DOCUMENTS

2,799,865 A 7/1957 Schuster
 3,040,769 A 6/1962 Lamb
 3,086,546 A 4/1963 Brown
 3,172,128 A 3/1965 Ducey
 3,321,972 A 5/1967 Goldtrap
 3,457,947 A 7/1969 Fitzgerald
 3,744,064 A 7/1973 Preston
 3,762,395 A 10/1973 Taylor
 3,986,216 A 10/1976 Davis et al.
 3,994,628 A 11/1976 Kemper
 4,007,498 A 2/1977 Pearson
 4,017,916 A 4/1977 Pearson
 4,032,822 A 6/1977 Un
 4,090,532 A 5/1978 Story, Jr.
 4,134,164 A 1/1979 Sanmartin Rial
 4,145,775 A 3/1979 Butler
 4,351,071 A 9/1982 Clar
 4,392,260 A 7/1983 Bensen
 4,420,845 A 12/1983 Antunez
 4,505,231 A 3/1985 Syler
 4,527,295 A 7/1985 Lacore
 4,700,413 A 10/1987 Lopez
 4,707,867 A 11/1987 Kawabe et al.
 4,764,996 A 8/1988 Pino
 4,770,388 A 9/1988 Carman
 4,793,588 A 12/1988 Laverly, Jr.
 4,898,124 A 2/1990 Granberg et al.
 4,918,764 A 4/1990 Haselswerdt et al.
 4,980,932 A 1/1991 Stemples
 5,007,452 A 4/1991 Antunez
 5,036,553 A 8/1991 Sanderson
 5,052,060 A 10/1991 Makita et al.
 5,083,323 A 1/1992 Cannan
 5,134,729 A 8/1992 Shaw
 5,228,152 A 7/1993 Fraley
 5,232,011 A 8/1993 Royalty

5,245,710 A 9/1993 Haselswerdt et al.
 5,327,931 A 7/1994 Royalty
 5,362,026 A 11/1994 Kobayashi et al.
 5,432,959 A 7/1995 Ellsworth et al.
 5,442,820 A 8/1995 Becker
 5,469,586 A 11/1995 Tsutsui et al.
 5,542,448 A 8/1996 Campbell et al.
 5,624,073 A 4/1997 Mueller et al.
 5,708,991 A 1/1998 DeMarco
 5,715,860 A 2/1998 Horad
 5,742,951 A 4/1998 Wright et al.
 5,775,366 A 7/1998 Ray
 5,794,279 A 8/1998 Schwartz
 5,862,537 A 1/1999 Osmond
 5,926,868 A 7/1999 Bjerke
 6,047,725 A 4/2000 Gish et al.
 6,202,227 B1 3/2001 Gurowitz
 6,209,576 B1 4/2001 Davis
 6,219,856 B1 4/2001 Alles
 6,263,519 B1 7/2001 Parsons et al.
 6,295,660 B1 10/2001 Schuster
 6,385,788 B1 5/2002 Wasielewski
 6,409,221 B1 6/2002 Robinson et al.
 6,560,790 B2 5/2003 Saar et al.
 6,823,889 B1 11/2004 Schuster
 2002/0092090 A1 7/2002 Johnson
 2002/0162166 A1 11/2002 Saar et al.
 2004/0199989 A1* 10/2004 Trolie 4/427

OTHER PUBLICATIONS

US Patent 7,743,436, File History, 2004-2010 Great-Grandparent Patent to this Application.
 US Patent 8,104,105, File History, (2010-2012) Grandparent to this Application.
 U.S. Appl. No. 13/346,355 File History (2012-2014) Parent to this Application.

* cited by examiner

1
2
3
4
5
6
7
8
9
10
11
12
13
14
15
16
17
18
19
20
21
22
23
24
25
26
27
28

U.S. Patent

Aug. 11, 2015

Sheet 1 of 9

US 9,103,105 B1

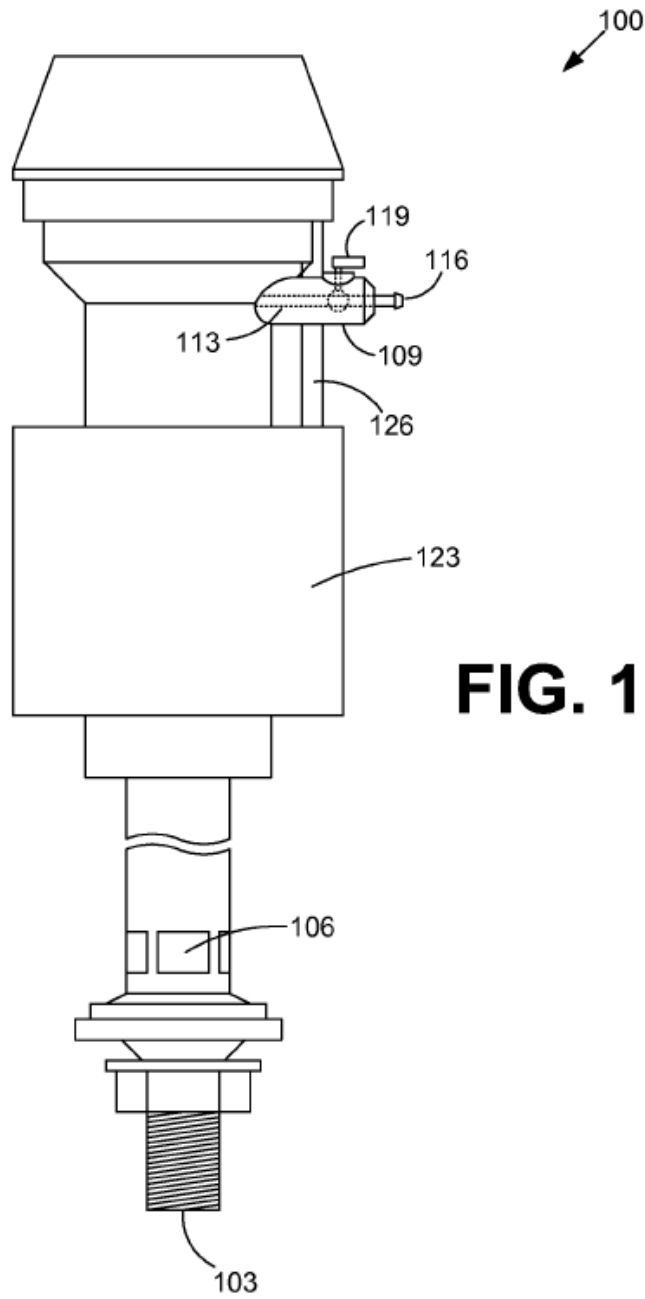

1
2 **U.S. Patent**

Aug. 11, 2015

Sheet 2 of 9

US 9,103,105 B1

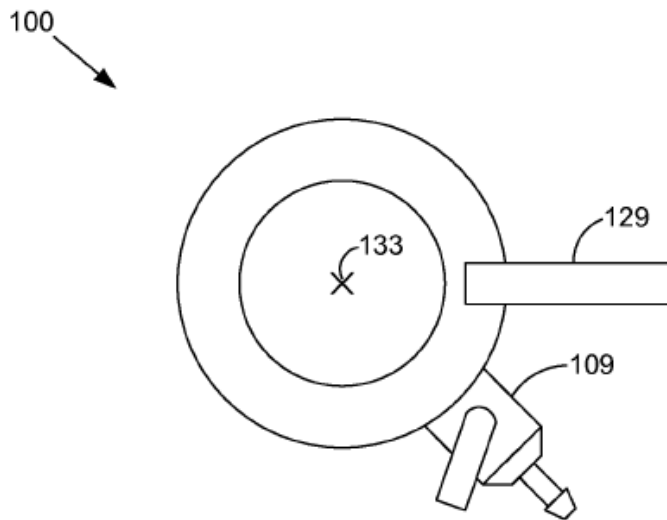

FIG. 2

U.S. Patent

Aug. 11, 2015

Sheet 3 of 9

US 9,103,105 B1

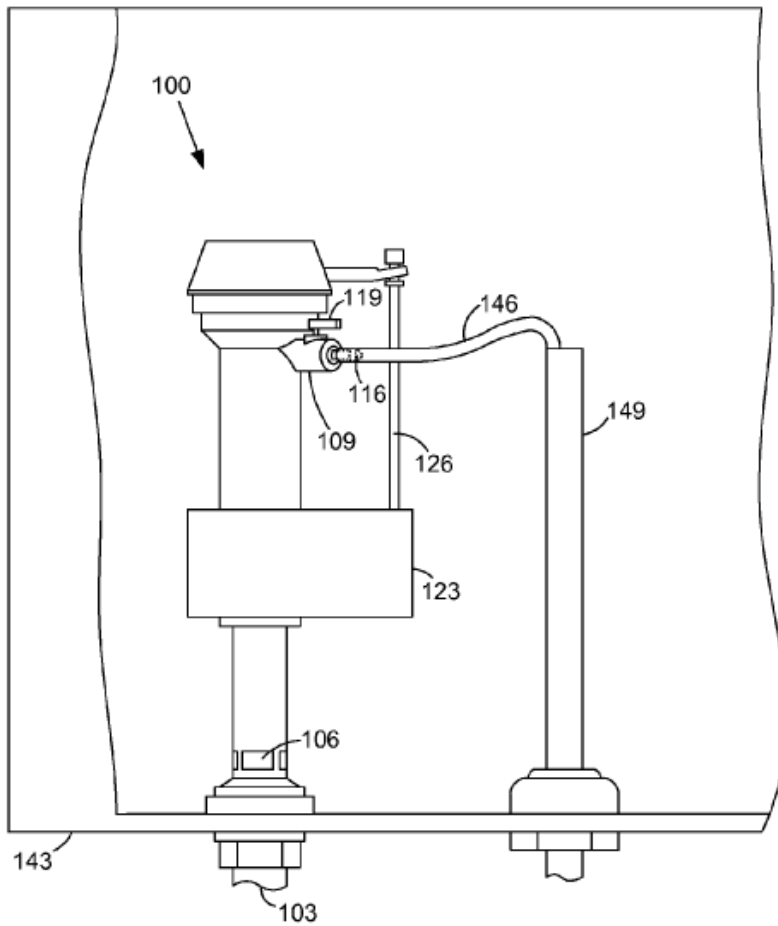

FIG. 3

U.S. Patent

Aug. 11, 2015

Sheet 4 of 9

US 9,103,105 B1

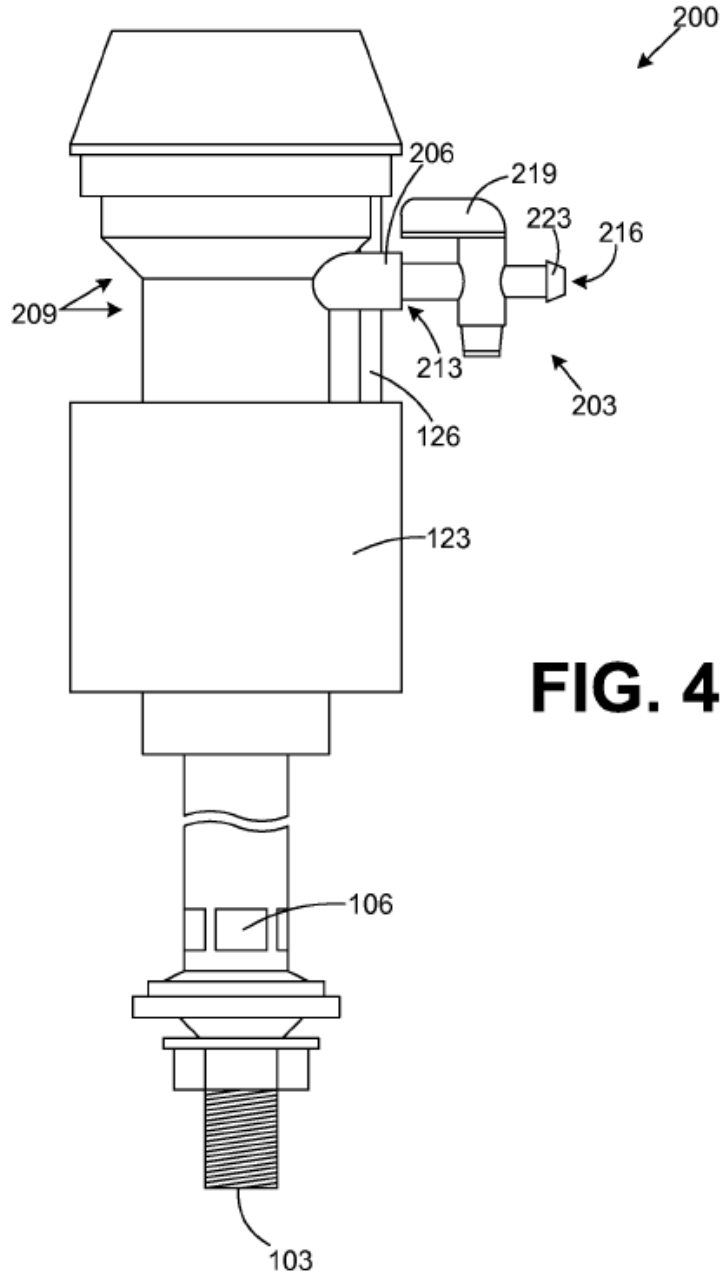

FIG. 4

U.S. Patent

Aug. 11, 2015

Sheet 5 of 9

US 9,103,105 B1

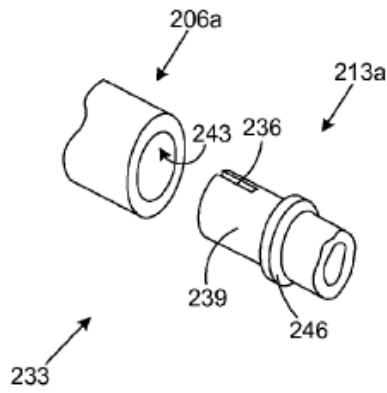

FIG. 5A

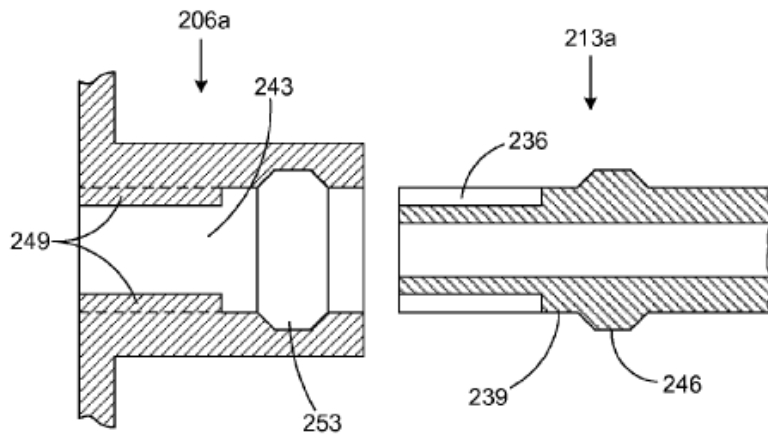

FIG. 5B

U.S. Patent

Aug. 11, 2015

Sheet 6 of 9

US 9,103,105 B1

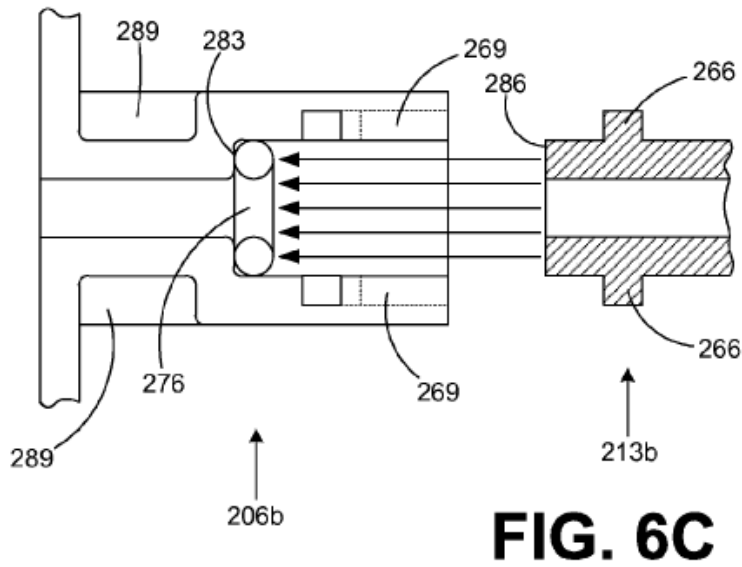
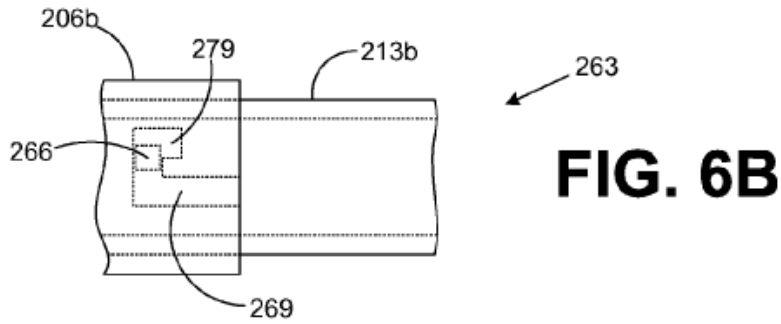
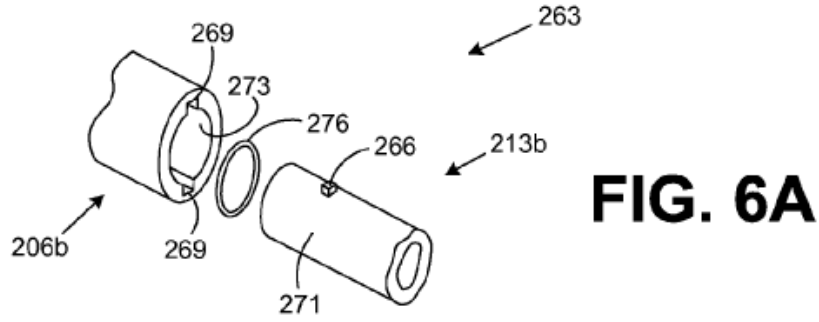

U.S. Patent

Aug. 11, 2015

Sheet 7 of 9

US 9,103,105 B1

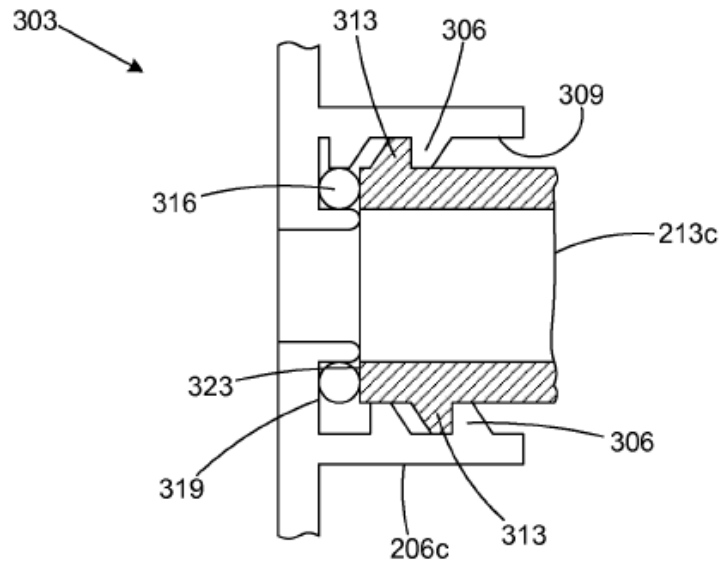

FIG. 7

U.S. Patent

Aug. 11, 2015

Sheet 8 of 9

US 9,103,105 B1

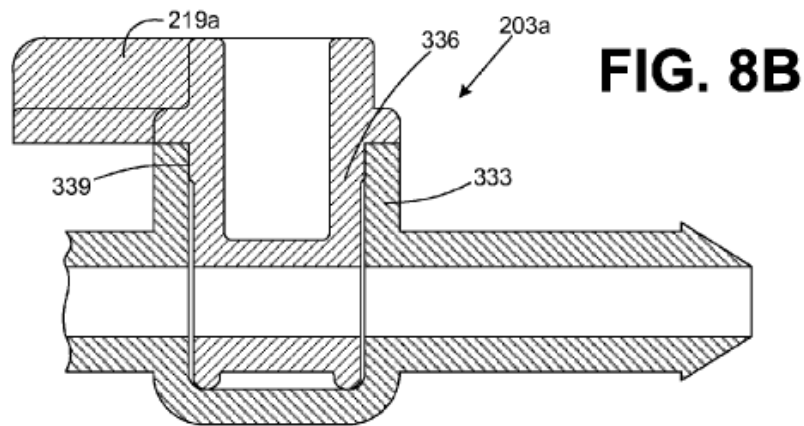
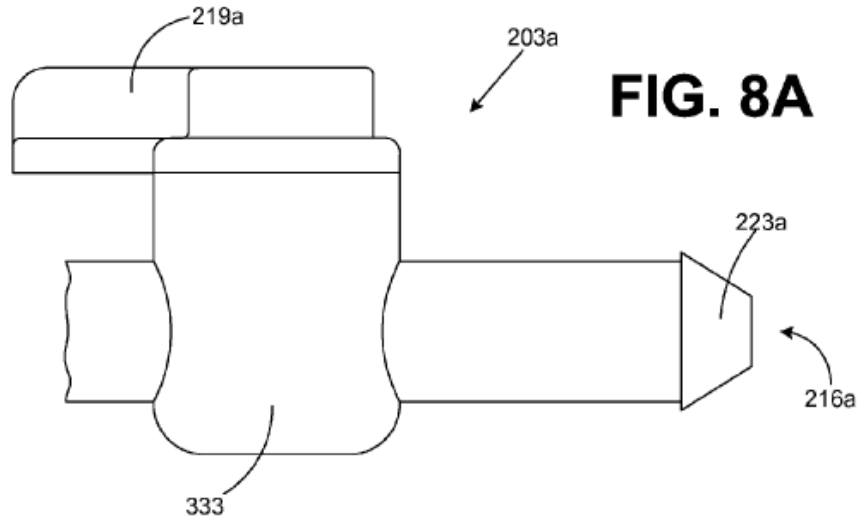

U.S. Patent

Aug. 11, 2015

Sheet 9 of 9

US 9,103,105 B1

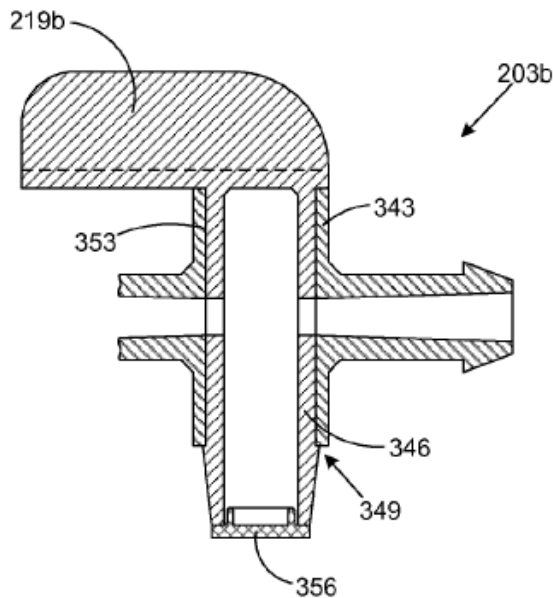
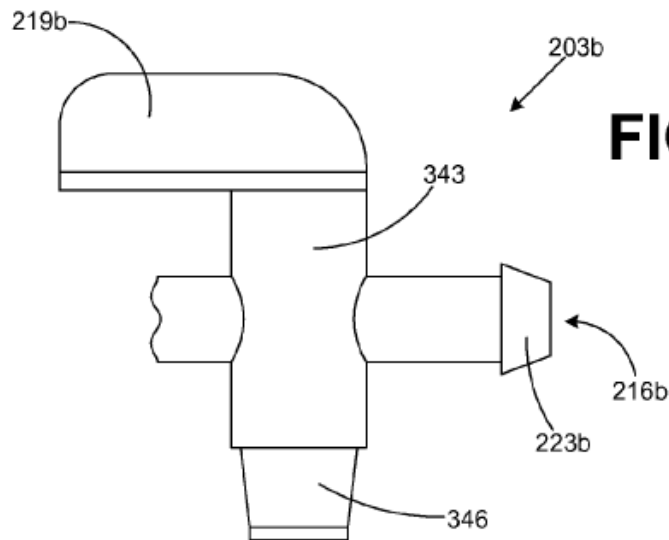

1
TOILET FILL VALVE

CROSS REFERENCE TO RELATED APPLICATIONS

The present patent application is a Continuation Application of, and claims priority to, U.S. Patent Application entitled "Toilet Fill Valve" filed on Jan. 27, 2014 and assigned Ser. No. 14/164,424, which is a Continuation Application of, and claims priority to, U.S. Pat. No. 8,650,671 entitled "Toilet Fill Valve with Adjustable Bowl Fill Flow" filed on Jan. 9, 2012, which is a Continuation Application of, and claims priority to, U.S. Pat. No. 8,104,105 entitled "Toilet Fill Valve with Adjustable Bowl Fill Flow" filed on May 25, 2010, which is a Continuation Application of, and claims priority to, U.S. Pat. No. 7,743,436 entitled "Toilet Fill Valve with Adjustable Bowl Fill Flow" filed on Oct. 5, 2004, which is a Continuation-in-Part Application of, and claims priority to, U.S. Pat. No. 6,823,889 entitled "Toilet Fill Valve with Adjustable Bowl Fill Flow" filed on Mar. 11, 2004.

BACKGROUND

A toilet fill valve in a toilet typically includes a water outlet that provides water for refilling a toilet bowl during a flush cycle. Unfortunately, the water flowing out of such conventional water outlets to fill a toilet bowl provide much more water than is necessary to fill the average toilet bowl. Consequently, much of the water that flows into a toilet bowl during the average flush cycle is lost down the drain. This translates into a loss of millions of gallons of water each year.

BRIEF DESCRIPTION OF THE SEVERAL VIEWS OF THE DRAWINGS

The invention can be understood with reference to the following drawings. The components in the drawings are not necessarily to scale. Also, in the drawings, like reference numerals designate corresponding parts throughout the several views.

FIG. 1 is a drawing of a side view of a toilet fill valve according to an embodiment of the present invention;

FIG. 2 is a drawing of a top view of the toilet fill valve of FIG. 1;

FIG. 3 is a drawing of a cutaway view of a toilet tank within which the toilet fill valve of FIG. 1 is installed;

FIG. 4 is a drawing of a side view of a toilet fill valve according to an embodiment of the present invention;

FIGS. 5A and 5B are drawings that illustrate one example of a coupling of a bowl fill valve to the toilet fill valve of FIG. 4 according to an embodiment of the present invention;

FIGS. 6A, 6B, and 6C are drawings that illustrate another example of a coupling of a bowl fill valve to the toilet fill valve of FIG. 4 according to an embodiment of the present invention;

FIG. 7 is a drawing that illustrates still another example of a coupling of a bowl fill valve to the toilet fill valve of FIG. 4 according to an embodiment of the present invention;

FIGS. 8A and 8B are drawings that illustrate an example of a bowl fill valve that is coupled to the toilet fill valve of FIG. 4 according to an embodiment of the present invention; and

FIGS. 9A and 9B are drawings that illustrate another example of a bowl fill valve that is coupled to the toilet fill valve of FIG. 4 according to an embodiment of the present invention.

DETAILED DESCRIPTION

With reference to FIG. 1, shown is a toilet fill valve 100 according to an embodiment of the present invention. The

2

toilet fill valve 100 includes a water inlet 103 at the bottom of the toilet fill valve 100 that is configured to be coupled to a water source outside of a toilet tank within which the toilet fill valve 100 is installed. The toilet fill valve 100 includes one or more water outlets 106 that are configured to supply water into a toilet tank within which the toilet fill valve 100 is installed. The toilet fill valve 100 may be, for example, a pilot style fill valve. However, it is understood that the toilet fill valve 100 may be any style of fill valve such as, for example, a ballcock valve, etc. The toilet fill valve 100 also includes a bowl fill valve 109 according to an embodiment of the present invention. The bowl fill valve 109 includes a bowl fill valve inlet 113 and a bowl fill valve outlet 116. In addition, the bowl fill valve 109 includes a handle 119 that facilitates a manual adjustment of the bowl fill valve 109.

The bowl fill valve 109 is integral with the toilet fill valve 100. In this respect, the term "integral" refers to the fact that the bowl fill valve 109 and the toilet fill valve 100 comprise a single structure. In this respect, the bowl fill valve 109 may be included within the body of the toilet fill valve 100 as a portion of the toilet fill valve 100 in a single piece construction. Specifically, the bowl fill valve 109 may be molded as a portion of the toilet fill valve 100 or it may be snapped or clamped into place, or it may be attached to the toilet fill valve 100 in some other manner, etc.

Within the toilet fill valve 100, the bowl fill valve inlet 113 is operatively coupled to the water inlet 103. In this respect, when the toilet fill valve 100 is open and water flows from the water inlet 103 to the water outlets 106 and into a toilet tank, an amount of water is also supplied to the bowl fill valve inlet 113 that flows through the bowl fill valve 109 and out the bowl fill valve outlet 116. By virtue of the manual setting of the handle 119 of the bowl fill valve 109, the flow of water through the bowl fill valve 109 is regulated. In this manner, the flow of water is regulated so that enough water flows out of the bowl fill valve 109 to fill a toilet bowl without wasting any water down a drain.

Thus, the bowl fill valve 109 is configured to supply an adjustable flow of water out of the bowl fill outlet 116 that is directed to a toilet bowl during a flush cycle of a toilet to fill the toilet bowl. The flow of water is adjusted so that just enough flows out of bowl fill valve 109 so as to fill the toilet bowl without wasting any water.

The toilet fill valve 100 includes a float 123 that is operatively coupled to an actuating arm (not shown) by a translating stem 126. The float 123 floats on the water within a toilet tank and, depending on the location of the float 123 along the toilet fill valve 100, the toilet fill valve 100 is open or closed as can be appreciated by those with ordinary skill in the art. The bowl fill valve 109 and the actuating arm (not shown) are each located on the toilet fill valve 100 so as to prevent any interference between the bowl fill valve 109 and the translational stem 126 or the actuating arm as will be discussed.

According to an embodiment of the present invention, the bowl fill valve 109 may include a number of biased positions. In this respect, the movement of the handle 119 may cause the bowl fill valve 109 to move from one predefined biased position to other predefined biased positions. In this respect, various mechanisms such as tabs, snaps, or other position biasing structures may be employed. The biased positions of the bowl fill valve 109 help ensure that the bowl fill valve 109 remains in a given setting selected by a user by a manual manipulation of the handle 119 during the normal course of operation of the toilet fill valve 100. Thus, by virtue of the biased positions, the bowl fill valve 109 is prevented from moving out of a desired

1
2
3
4
5
6
7
8
9
10
11
12
13
14
15
16
17
18
19
20
21
22
23
24
25
26
27
28

US 9,103,105 B1

3

position set by a user over a long period of use due to vibration and other factors as can be appreciated by those with ordinary skill in the art.

The bowl fill valve 109 may be, for example, a ball valve, a gate valve, a globe valve, a plug valve, a diaphragm valve, a butterfly valve, a needle valve, a sliding gate, a quick turn valve, a knife valve or any other appropriate type of valve as can be appreciated by those with ordinary skill in the art.

To operate the toilet fill valve 100, the toilet fill valve 100 is first installed within a toilet tank. When a toilet is flushed and the tank is drained, the float 123 moves downward along the toilet fill valve 100 and, consequently, the toilet fill valve 100 opens to allow water to flow from the water inlet 103 and out the water outlets 106 into a toilet tank. At the same time, water flows into the bowl fill valve inlet 113 and out the bowl fill valve outlet 116 through the bowl fill valve 109. Based on the setting of the handle 119, the bowl fill valve 109 determines the precise flow rate of the water that flows out the bowl fill valve outlet 116. A tube is typically employed to direct the water flowing out the bowl fill valve outlet 116 to an overflow tube in the toilet tank. In this respect, the water flowing out the bowl fill valve outlet 116 refills the toilet bowl of the respective toilet.

Referring next to FIG. 2, shown is a top view of the toilet fill valve 100 according to an embodiment of the present invention. In this respect, the actuating arm 129 of the bowl fill valve 100 is seen with respect to the bowl fill valve 109. The actuating arm 129 is coupled to the float by way of the translational stem 126 (FIG. 1). In this respect, the actuating arm 129 extends in an orthogonal direction relative to a longitudinal axis 133 of the toilet fill valve 100. The longitudinal axis 133 is centered in the toilet fill valve 100 along the length of the toilet fill valve 100. Also, the bowl fill valve 109 extends in an orthogonal direction relative to the longitudinal axis 133 of the toilet fill valve 100. In order to prevent interference between the bowl fill valve 109 and the translational stem 126 or the actuating arm 129, the actuating arm 129 is angularly offset relative to the bowl fill valve 109 as shown. In this respect, the translational stem 126 is coupled to the free end of the actuating arm 129. By virtue of the angular offset between the bowl fill valve 109 and the actuating arm 129, the operation of the bowl fill valve 109 does not interfere with the operation of the toilet fill valve 100 itself by virtue of the fact that the float 123 (FIG. 1) can move freely with the movement of the translational stem 126 in order for proper operation of the toilet fill valve 100.

With reference to FIG. 3, shown is the toilet fill valve 100 as installed within a toilet tank 143 according to an embodiment of the present invention. In this respect, the toilet fill valve 100 includes the water inlet 103 that is coupled to a water source outside of the toilet tank 143. The toilet fill valve 100 also includes one or more water outlets 106 that direct a flow of water into the toilet tank 143 during the operation of a flush cycle. The bowl fill valve 109 includes the bowl fill valve inlet (not shown) and the bowl fill valve outlet 116, where the bowl fill valve inlet is operatively coupled to the water inlet 103 as described above. Also, the bowl fill valve 109 is integrated with the body of the toilet fill valve 100 as described above.

A tube 146 is coupled to the bowl fill valve outlet 116 and is directed into the overflow tube 149 of the toilet tank 143. The tube 146 directs water that flows out of the bowl fill valve outlet 116 into the overflow tube 149 and refills the toilet bowl associated with the toilet tank 143 as can be appreciated by those with ordinary skill in the art. The bowl fill valve 109 is configured to supply the adjustable flow of water out the bowl fill valve outlet through the tube 146 and into the overflow

4

tube 149 for filling the toilet bowl during the flush cycle of the toilet. In this respect, no pressure is seen within the tube 146. Specifically, the fact that the bowl fill valve 109 is integral with the toilet fill valve 100 prevents the creation of a pressure head in the tube 146 as would be the case if the bowl fill valve 109 were included in the middle of the tube 146. The fact that a pressure head is not created in any portion of the tube 146 prevents the tube 146 from working its way off of the bowl fill valve outlet 116 over time.

When installed, the bowl fill valve 109 is calibrated for the particular flush cycle of the toilet within which the toilet fill valve 100 is installed. To calibrate the bowl fill valve 109, a user first determines the water level in the toilet bowl when the toilet bowl is full of water. This gives the user a starting and an ending point for determining when the toilet bowl of the respective toilet is full. Next, the bowl fill valve handle 109 is adjusted so that the bowl fill valve 109 is placed in a predefined position that allows a predefined flow of water to refill the toilet bowl. In this manner, one adjusts the actual flow of water that refills the toilet bowl. Thereafter, the user flushes the toilet itself. Next, the user determines if the flow of water into the toilet bowl by virtue of the adjustments made to the bowl fill valve 109 is adequate to refill the toilet bowl during the flush cycle. This may be determined, by identifying whether the level of the water in the toilet bowl reaches the full level determined at the beginning of the bowl fill valve calibration above.

The flow of water from the bowl fill valve 109 should be set so as to ensure that the water level in the toilet bowl reaches the full level at about the same time that the flush cycle ends. In other words, the level of water in the toilet bowl should reach its highest level at the same time that the flush cycle ends. This prevents any water from being lost down the drain associated with the toilet.

If the amount of water that flows into the toilet bowl is inadequate to refill the toilet bowl during the flush cycle as described above, then one should repeat the steps of adjusting the bowl fill valve, flushing the toilet, and then once again determining if the flow of water into the toilet bowl is adequate to refill the toilet bowl during a flush cycle.

Ultimately, during use of the toilet that includes the toilet fill valve 100 and the toilet tank 143, a user flushes the toilet and a predetermined flow of water exits the bowl fill valve outlet 116 and is directed into the toilet bowl. After the toilet tank has drained during the flush cycle, a flapper closes in the toilet tank and the toilet tank refills. During the refilling of the tank, the water supplied by the bowl fill valve 109 fills the toilet bowl itself. The amount of water supplied by the bowl fill valve in the time it takes to refill the toilet tank should be approximately equal to the amount of water needed to fill the toilet bowl. By virtue of the fact that the bowl fill valve 100 is integrated within the toilet fill valve 100, a pressure head is prevented from being created due to any potential pinching of the tube 146 or other similar adjustment mechanism.

With reference to FIG. 4, shown is a toilet fill valve 200 according to another embodiment of the present invention. The toilet fill valve 200 includes the same water inlet 103 and the water outlets 106 as the toilet fill valve 100 (FIG. 1). The toilet fill valve 200 also includes the float 123 and the translational stem 126 as was described with reference to the toilet fill valve 100. In addition, the toilet fill valve 200 includes a bowl fill valve 203 that is integral with the toilet fill valve 200 as will be described. As stated above, the term "integral" refers to the fact that the bowl fill valve 200 and the toilet fill valve 100 comprise a single structure. In this embodiment, the

US 9,103,105 B1

5

bowl fill valve 200 is a separate component that is attached to the body of the toilet fill valve 100, thereby forming the integral, single structure.

The toilet fill valve 200 also includes a bowl fill outlet port 206 that radially extends from a portion of a body 209 of the toilet fill valve 200. In this respect, the bowl fill outlet port is operatively coupled to the water inlet 103. In particular, when the toilet fill valve 200 is in an "on" state, water that flows in the water inlet 103 flows out of both the water outlets 106 and the bowl fill outlet port 206. The water flowing out of the bowl fill outlet port 206 flows through the bowl fill valve 203 as will be described.

The bowl fill valve 203 includes a bowl fill valve inlet port 213 and a bowl fill valve outlet port 216. The bowl fill valve inlet port 213 is compatible with the bowl fill outlet port 206, where the bowl fill valve inlet port 213 is coupled to the bowl fill outlet port 206 when the bowl fill valve 203 is coupled or affixed to the toilet fill valve 200. The bowl fill valve inlet port 213 is compatible with the bowl fill outlet port 206 in the sense that both the bowl fill valve inlet port 213 and the bowl fill outlet port 206 comprise various structures that couple together when the bowl fill valve 203 is connected to the bowl fill outlet port 206 as will be described. In particular, various embodiments of the coupling between the bowl fill valve inlet port 213 and the bowl fill outlet port 206 are described herein.

The bowl fill valve 203 also includes a handle that may be adjusted by hand to adjust a flow of water through the bowl fill valve 203 during a flush operation of a toilet in which the toilet fill valve 200 is installed. Typically, the handle 219 is initially adjusted to a desired position when the toilet fill valve 200 is installed and generally remains in such position for the continued operation of the toilet fill valve 200. During the life cycle of the bowl fill valve 203, it may be possible that the bowl fill valve 203 is adjusted to take into account various changes in the operation of the toilet fill valve 200 such as, for example, changes in pressure or other operational changes.

The bowl fill valve 203 also includes a nipple 223. The nipple 223 is adapted to mate with a tube that extends from the bowl fill valve outlet port 216 to the overflow tube 149 (FIG. 3) in a manner similar to that as shown in FIG. 3 with respect to the tube 146 (FIG. 3) that extends from the nipple 116 (FIG. 3) to the overflow tube 149 (FIG. 3). The bowl fill valve 203 extends beyond the bowl fill outlet port 206 in a radial direction with respect to the portion of the body 209 of the toilet fill valve 200.

In some embodiments, the bowl fill outlet port 206 may comprise a female receptacle and, correspondingly, the bowl fill valve inlet port 213 may comprise a male end compatible with the female receptacle. Alternatively, the bowl fill valve inlet port 213 may comprise a female receptacle and the bowl fill outlet port 206 may comprise a male end compatible with such female receptacle.

The toilet fill valve 200 further includes an actuating arm (not shown) that extends in a radial direction that is orthogonal relative to a longitudinal axis of the toilet fill valve 200 in a manner similar as that described with reference to the toilet fill valve 100 (FIG. 1). The longitudinal axis is defined as an axis that runs from the water inlet 103 through the body 209 of the toilet fill valve 200 and out the top of the toilet fill valve 200. In one embodiment, the bowl fill valve 203 extends radially in an orthogonal direction relative to such longitudinal axis of the toilet fill valve 200. Also, in one embodiment, the actuating arm is angularly offset relative to the bowl fill valve 203 to prevent interference between the bowl fill valve 203 and the translational stem 126 that extends from the float 123 to a free end of the actuating arm. This allows the float

6

123 to move up and down and to engage the actuating arm during the normal operation of the toilet fill valve 200 during various flush cycles.

In addition, the bowl fill valve 203 may be constructed with a number of biased positions that help prevent the bowl fill valve 203 from moving out of adjustment over time when the force of pressure develops therein. Also, the biased positions aid a user in actual adjustment of the bowl fill valve 203 as can be appreciated.

The toilet fill valve 200 provides an advantage in that the body 209 of the toilet fill valve 200 may be constructed with the bowl fill outlet port 206 using a molding process that is much less complex than attempting to mold the entire bowl fill valve 203 within the structure of the body 209 as a single molded construction as was described with reference to one embodiment of the toilet fill valve 100. In this regard, the bowl fill valve 203 may be constructed as a separate component to the body 209 of the toilet fill valve 200 and assembled for distribution to end users.

Due to the fact that the bowl fill valve 203 is affixed to the toilet fill valve 200 through the coupling of the bowl fill outlet port 206 with the bowl fill valve inlet port 213, then a pressure head that develops within the bowl fill valve 203 due to the adjustment of the handle 219 during operation of the toilet fill valve 200 will not cause the bowl fill valve 203 to fall off of the toilet fill valve 200. Thus, when the toilet fill valve 200 is installed in a toilet tank 143, a user may adjust the opening of the bowl fill valve 203 by adjusting the handle 219 until a desired flow of water flows out of the bowl fill valve outlet port 216 into a tube and into the overflow tube 149 of a toilet. This flow of water is typically established to refill a toilet bowl of a toilet. In this regard, the flow of the water into the overflow tube 149 that refills the toilet bowl during a toilet flush operation may be regulated or adjusted so as to minimize or eliminate the amount of water that is lost down the drain of a toilet due to over filling of the toilet bowl during a flush cycle of a toilet. In one embodiment, the bowl fill valve 203 is adjusted until the filling of the toilet bowl of the toilet coincides with the end of the flush cycle, thereby resulting in little or no loss of water.

Referring next to FIG. 5A, shown is a coupling 233 between one embodiment of the bowl fill outlet port 206, denoted herein as bowl fill outlet port 206a, and an embodiment of the bowl fill valve inlet port 213, denoted herein as bowl fill valve inlet port 213a. The bowl fill valve inlet port 213a includes a slot 236 in a side wall 239. The bowl fill outlet port 206a comprises a rib (not shown) that extends from a side wall 243 that is inserted into the slot 236 when the bowl fill inlet port 213a is inserted into the bowl fill outlet port 206a. The mating of the slot 236 with the rib prevents the rotation of the bowl fill valve 213a with respect to the bowl fill outlet port 206a when the bowl fill valve inlet port 213a is inserted into the bowl fill outlet port 206a. Alternatively, there may be a number of slots 236 in the side wall 239 of the bowl fill valve inlet port 213a and a corresponding number of ribs extending from the side wall 243 of the bowl fill outlet port 206a.

The bowl fill valve inlet port 213a also includes an annular protrusion 246 that extends from the side wall 239 of the bowl fill valve inlet port 213a. Correspondingly, an annular groove (not shown) in the side wall 243 of the bowl fill valve outlet port 206a is provided that mates up with the annular protrusion 246 when the bowl fill valve inlet port 213 is inserted into the bowl fill outlet port 206a. In this respect, the annular protrusion 246 is snap fit into the annular groove (not shown), thereby affixing the bowl fill valve 203a to the bowl fill valve outlet port 206a.

1
2
3
4
5
6
7
8
9
10
11
12
13
14
15
16
17
18
19
20
21
22
23
24
25
26
27
28

US 9,103,105 B1

7

Turning then to FIG. 5B, shown is a cutaway view of the coupling 233 between the bowl fill outlet port 206a and the bowl fill valve inlet port 213a according to an embodiment of the present invention. In this respect, the bowl fill outlet port 206a is depicted with two ribs 249 extending from the side wall 243 within the bowl fill outlet port 206a. Also, the bowl fill outlet port 206a includes the annular groove 253 into which the annular protrusion 246 snaps when the bowl fill valve inlet port 213a is inserted into the bowl fill outlet port 206a. In this respect, the mating of the annular protrusion 246 with the annular groove 253 fixes the bowl fill valve 203 to the bowl fill outlet port 206a. In this respect, the bowl fill valve 203 becomes an integral portion of the toilet fill valve 200.

Also, the fit between the annular protrusion 246 is a snug fit that forms a seal between the bowl fill outlet port 206a and the bowl fill valve inlet port 213a that prevents the leakage of water from the coupling 233 during a flush cycle. Alternatively, a snug fit may occur between other mating surfaces of the bowl fill outlet port 206a and the bowl fill valve inlet port 213a that prevents leakage of water from the coupling 233.

With reference to FIGS. 5A and 5B, even though the slots 236 are depicted as being formed within the side wall 239 of the bowl fill valve inlet port 213 and the ribs 249 extend from the side wall 243 within the bowl fill outlet port 206, it is possible that this arrangement may be reversed where the slots 236 are formed in the side wall 243 of the bowl fill outlet port 206a and the ribs 249 extend from the side wall 239 of the bowl fill valve inlet port 213a. In addition, the annular groove 253 may be created in the side wall 239 of the bowl fill valve inlet port 213 and the annular projection 246 may extend inward from the side wall 243 within the bowl fill outlet port 206 in a reverse arrangement than that shown with reference to FIG. 5B.

Referring next to FIGS. 6A, 6B, and 6C, shown is a coupling 263 between another embodiment of the bowl fill outlet port 206, denoted herein as bowl fill outlet port 206b, and another embodiment of the bowl fill valve inlet port 213, denoted herein as bowl fill valve inlet port 213b. The bowl fill valve inlet port 213b includes at least two locking ears 266 that mate with corresponding locking grooves 269 in the bowl fill outlet port 206b. In particular, the locking ears 266 extend from a side wall 271 of the bowl fill valve inlet port 213b. The locking grooves 269 are disposed in the side wall 273 of the bowl fill outlet port 206b. When the bowl fill valve 203 is inserted and twisted into the bowl fill outlet port 206b, each of the locking ears 266 is situated in a locking position of one of the locking grooves 269 as will be described. The coupling 263 further comprises a sealing ring 276 that may be, for example, a rubber O-ring or other type of sealing ring. The sealing ring 276 is compressed between an end of the bowl fill valve inlet port 213b and a seat within the bowl fill outlet port 206b as we described. While at least two locking ears 266 and corresponding locking grooves 269 are shown, it is possible that a design may be employed that comprises a single locking ear 266 and a single corresponding locking groove 269.

With reference to FIG. 6B, shown is a portion of the bowl fill valve inlet port 213b and the bowl fill outlet port 206b as the bowl fill valve inlet port 213b is inserted into the bowl fill outlet port 206b and is partially rotated such that the locking ears 266 are almost located in the locking positions 279. In this respect, each of the locking grooves 269 is a "J" formation. The J formation of the locking grooves 269 allows the locking ears 266 to slide down and around the partial loop of the J and seat in the locking position 279 such that the sealing ring 276 exerts a force against the end of the bowl fill valve inlet port 213b, thereby pushing the locking ears 266 into the locking positions 279 of the locking grooves 269 and holding

8

the locking ears 266 in place. This ensures that the bowl fill valve 203 remains coupled to the bowl fill outlet port 206b.

With reference to FIG. 6C, shown is a cutaway view of the coupling 263 between the bowl fill outlet port 206b and the bowl fill valve inlet port 213b. In this respect, the bowl fill valve inlet port 213b is inserted into the bowl fill outlet port 206b in a manner such that the locking ears 266 mate with the locking grooves 269. When the locking ears 266 reach the bottom of the "J" of the locking grooves 269, then the bowl fill valve 203 is rotated so that the locking ears 266 may be seated in the locking positions 279.

The sealing ring 276 is seated against a portion of the bowl fill outlet port 206b. In one embodiment, this portion is a seating face 283 of the bowl fill outlet port 206b. Also, a portion of the bowl fill valve inlet port 213b is mated against the sealing ring 276. In one embodiment, this portion of the bowl fill valve inlet port 213b is an end face 286 such that the sealing ring is clamped between the seating face 283 and the end face 286 when the bowl fill valve inlet port 213b is inserted fully into the bowl fill outlet port 206b. The clamping or compression of the sealing ring 276 pushes the locking ears 266 into the locking position 279 of the locking grooves 269 once the bowl fill valve 203 is rotated accordingly. In this respect, the compressive force of the sealing ring 276 helps keep the bowl fill valve inlet port 213b of the bowl fill valve 203 mated with the bowl fill outlet port 206b. Also, the sealing ring 276 forms a seal between the bowl fill outlet port 206b and the bowl fill valve inlet port 213b that prevents leakage of water from the coupling 263 between the bowl fill outlet port 206b and the bowl fill valve inlet port 213b.

The locking positions 279 of the locking grooves and the locking ears 266 are located such that when the bowl fill valve 203 is rotated thereby positioning the locking ears 266 in the locking positions 279, the bowl fill valve 203 is substantially upright. In addition, the bowl fill outlet port 206b includes structural ribs 289 that provide greater structural stability for the bowl fill outlet port 206b and its attachment to the portion of the body 209 of the toilet fill valve 200 (FIG. 4). Alternatively, the bowl fill outlet port 206b may be attached without the structural ribs 289. In addition, it may be the case that the locking ears 266 extend inward from the side wall 273 of the bowl fill outlet port 206b and that the locking grooves 269 be situated within the side wall 271 of the bowl fill valve inlet port 213b.

Referring next to FIG. 7, shown is a cutaway view of a coupling 303 between a third embodiment of the bowl fill outlet port 206, denoted herein as bowl fill outlet port 206c and the bowl fill valve inlet port 213, denoted herein as bowl fill valve inlet port 213c. In this respect, the bowl fill outlet port 206c includes a first thread 306 disposed on a side wall 309 of the bowl fill outlet port 206c. A second thread 313 is disposed on a side wall of the bowl fill valve inlet port 213c that engages the first thread 306 disposed in the side wall of the bowl fill outlet port 206c. The bowl fill valve inlet port 213c is coupled to the bowl fill outlet port 206c by way of the first and second threads 306 and 313. Specifically, the bowl fill valve 203 may be screwed onto the bowl fill outlet port 206c by virtue of the threads 306 and 313. When the bowl fill valve inlet port 213c is screwed into the bowl fill valve outlet port 206c, a sealing ring 316 is clamped between portions of the bowl fill valve inlet port 213c and the bowl fill outlet port 206c such as a seating face 319 of the bowl fill outlet port 206c and an end face 323 of the bowl fill valve inlet port 213c. In this respect, a seal is formed between the bowl fill outlet port 206c and the bowl fill valve inlet port 213c. Alternatively, the threads 306 and 313 may be specified so as to form an adequate seal between the bowl fill valve outlet port 206c and

1
2
3
4
5
6
7
8
9
10
11
12
13
14
15
16
17
18
19
20
21
22
23
24
25
26
27
28

US 9,103,105 B1

9

the bowl fill valve inlet port 213c for purposes of preventing leakage. As an additional alternative, the seating face 319 and the end face 323 or other portions of the bowl fill valve inlet port 213c and the bowl fill outlet port 206c may be compressed together to form a seal to prevent leakage. Alternatively, the bowl fill outlet port 206c and the bowl fill valve inlet port 213c may be designed to include mating surfaces that perform a friction seal as can be appreciated.

Referring next to FIG. 8a, shown is one embodiment of the bowl fill valve 203, denoted herein as bowl fill valve 203a according to an embodiment of the present invention. The bowl fill valve 203a includes a handle 219a and a valve body 333. The bowl fill valve 203a includes the bowl fill valve outlet port 216a and the bowl fill valve inlet port (not shown) the bowl fill outlet port 216a includes a nipple 223a.

Referring then to FIG. 8b, shown is a cutaway view of the bowl fill valve 203a according to an embodiment of the present invention. In this respect, the valve body 333 forms a cavity within which a valve 336 is inserted as shown. A line contact 339 is formed between surfaces of the valve body 333 and the valve 336 so as to both hold the valve 336 within the cavity that is formed by the valve body 333 and to form a seal between the valve body 333 and the valve 336 to prevent water leakage. As seen, the valve 336 is integrated with the handle 219a in a single piece construction, although multiple piece construction may be employed.

With reference to FIGS. 9a and 9b, shown is a second embodiment of the bowl fill valve 203, denoted herein as bowl fill valve 203b according to an embodiment of the present invention. The bowl fill valve 203b includes a valve body 343 within which is inserted a valve 346. The bowl fill valve 203b further comprises the bowl fill valve outlet port 216b and a bowl fill valve inlet port (not shown). The bowl fill valve outlet port 216b includes a nipple 223b. The bowl fill valve 203b further includes a handle 209b for manual adjustment of the bowl fill valve 203b.

Referring next to FIG. 9b, shown is a cutaway view of the bowl fill valve 203b according to an embodiment of the present invention. As shown, the valve 346 is inserted into the valve body 343. A snap fit 349 affixes the valve 346 within the valve body 343. A seal is formed by virtue of an interference fit 353 between a surface of the valve 346 and an inner surface of the valve body 343. The bottom of the cavity within the valve 346 is closed by a cap 356 that may be spin welded onto the valve 346 after the valve is inserted into the valve body 343.

In addition, referring back to FIG. 4, other types of couplings may be employed between the bowl fill outlet port 206 the bowl fill valve inlet port 213. For example, the bowl fill outlet port 206 the bowl fill valve inlet port 213 may be configured to facilitate a compression fitting there between. Also, other snap fit and sealing configurations may be employed beyond those specifically described herein.

Although the invention is shown and described with respect to certain embodiments, it is obvious that equivalents and modifications will occur to others skilled in the art upon the reading and understanding of the specification. The present invention includes all such equivalents and modifications, and is limited only by the scope of the claims.

What is claimed is:

1. A system, comprising:

a toilet fill valve that comprises:

a body comprising an extended portion, wherein the extended portion is integrally molded with the body, wherein the extended portion forms a bowl fill outlet port;

10

a water inlet configured to receive water from a water source; and

a tank water outlet configured to provide a first portion of the water to a toilet tank during at least a portion of a flush cycle;

a bowl fill restriction configured to attach directly to the extended portion of the body, wherein the bowl fill restriction comprises a protrusion that is configured to insert into a recess in the toilet fill valve to lock the bowl fill restriction to the extended portion of the body, wherein the bowl fill restriction is configured to receive a second portion of the water from the bowl fill outlet port during at least a portion of the flush cycle, wherein the restriction is configured to constrict a flow rate of the second portion of the water that flows through the bowl fill restriction; and

a tube that is configured to attach directly to the bowl fill restriction, wherein the tube is configured to direct the second portion of the water from the bowl fill restriction directly to a toilet tank overflow tube.

2. The system of claim 1, wherein the extended portion of the body extends radially from a longitudinal axis of the toilet fill valve.

3. The system of claim 1, wherein a portion of the bowl fill restriction is configured to insert into the extended portion of the body.

4. The system of claim 1, wherein the bowl fill restriction is configured to be clamped to the extended portion of the body.

5. The system of claim 1, wherein the bowl fill restriction is configured to be snapped onto the extended portion of the body.

6. The system of claim 1, wherein the toilet fill valve further comprises:

a float; and
an actuating arm coupled to the float, wherein the actuating arm extends radially relative to a longitudinal axis of the toilet fill valve, wherein the actuating arm is angularly offset relative to the bowl fill valve, thereby preventing an interference with the bowl fill restriction and a translational stem that extends from the float to a free end of the actuating arm.

7. The system of claim 1, wherein the bowl fill restriction further comprises a nipple that is configured to insert into the tube.

8. The system of claim 1, wherein the bowl fill restriction being attached directly to the extended portion of the body prevents a pressure head from being formed in the tube.

9. A method, comprising:

receiving, via a water inlet of a toilet fill valve, water from a water supply;

providing, via a tank water outlet of the toilet fill valve, a first portion of the water to a toilet tank;

providing, via a bowl fill outlet port of the toilet fill valve, a second portion of the water to a bowl fill restriction, wherein an extended portion of the toilet fill valve forms the bowl fill outlet port, wherein the extended portion is integrally molded with the toilet fill valve, wherein the bowl fill restriction is in direct contact with the extended portion of the toilet fill valve, wherein the bowl fill restriction is constructed as a single piece, wherein the bowl fill restriction causes a flow of the second portion of the water to be constricted;

providing, via the bowl fill restriction, the second portion of the water to a tube that is in direct contact with the bowl fill restriction; and

providing, via the tube, the second portion of the water to a toilet tank overflow tube.

1
2
3
4
5
6
7
8
9
10
11
12
13
14
15
16
17
18
19
20
21
22
23
24
25
26
27
28

US 9,103,105 B1

11

10. The method of claim 9, wherein the bowl fill restriction being in direct contact with the extended portion of the toilet fill valve prevents a pressure head from being formed in the tube.

11. The method of claim 9, further comprising terminating, using the toilet fill valve, the flow of the second portion of the water so that a water level in a toilet bowl is at a predefined level.

12. The method of claim 11, wherein the water level is determined at least in part by the bowl fill restriction.

13. The method of claim 9, wherein the extended portion of the toilet fill valve is a portion of a body of the toilet fill valve.

14. The method of claim 9, wherein the extended portion of the toilet fill valve extends radially from a longitudinal axis of the toilet fill valve.

15. A method, comprising:
attaching a bowl fill restriction directly to an extended portion of a body of a toilet fill valve, wherein the extended portion is integrally molded with the body, wherein the extended portion forms a bowl fill outlet port, wherein the bowl fill restriction is configured to constrict a flow rate of water that flows out of the bowl fill outlet port;
inserting a protrusion of the bowl fill restriction into a recess in the toilet fill valve to lock the bowl fill restriction to the extended portion of the body; and
attaching a tube directly to the bowl fill restriction, wherein the tube is configured to direct the water from the bowl fill restriction directly to a toilet tank overflow tube.

16. The method of claim 15, further comprising preventing the bowl fill restriction from detaching from the extended portion of the body.

17. The method of claim 16, wherein preventing the bowl fill restriction from detaching from the extended portion further comprises clamping the bowl fill restriction to the extended portion.

18. The method of claim 16, wherein preventing the bowl fill restriction from detaching from the extended portion further comprises snapping the bowl fill restriction to the extended portion.

12

19. The method of claim 16, wherein preventing the bowl fill restriction from detaching from the extended portion further comprises rotating the bowl fill restriction with respect to the extended portion.

20. The method of claim 15, wherein attaching a bowl fill restriction directly to the extended portion of the body of the toilet fill valve further comprises inserting a portion of the bowl fill restriction into the extended portion of the body.

21. The system of claim 1, wherein the bowl fill restriction is constructed of a single piece.

22. The method of claim 9, wherein the bowl fill restriction comprises a protrusion that is configured to insert into a recess in the toilet fill valve to lock the bowl fill restriction to the extended portion of the toilet fill valve.

23. The method of claim 15, wherein the bowl fill restriction is constructed of a single piece.

24. A system, comprising:
a toilet fill valve that comprises:
a body comprising an extended portion that forms a bowl fill outlet port, wherein the extended portion is integrally molded with the body;
a water inlet configured to receive water from a water source; and
a tank water outlet configured to provide a first portion of the water to a toilet tank during at least a portion of a flush cycle;

a bowl fill restriction configured to attach directly to the extended portion of the body of the toilet fill valve, wherein the bowl fill restriction comprises means for locking the bowl fill restriction to the extended portion of the body of the toilet fill valve, wherein the bowl fill restriction is configured to receive a second portion of the water from the bowl fill outlet port during at least a portion of the flush cycle, wherein the restriction is configured to constrict a flow rate of the second portion of the water that flows through the bowl fill restriction; and
a tube configured to attach directly to the bowl fill restriction, wherein the tube is configured to direct the second portion of the water from the bowl fill restriction to a toilet tank overflow tube.

* * * * *

EXHIBIT C
Danco's '698 Patent

1
2
3
4
5
6
7
8
9
10
11
12
13
14
15
16
17
18
19
20
21
22
23
24
25
26
27
28



(12) **United States Patent**
Schuster et al.

(10) **Patent No.: US 10,934,698 B1**
(45) **Date of Patent: *Mar. 2, 2021**

(54) **TOILET VALVE**

(58) **Field of Classification Search**

(71) Applicant: **Danco, Inc.**, Irving, TX (US)

CPC E03D 1/34; B23P 15/001
USPC 4/383, 418
See application file for complete search history.

(72) Inventors: **Michael J. Schuster**, Shorewood, IL (US); **Larry Schneider**, Wadsworth, IL (US)

(56) **References Cited**

(73) Assignee: **Danco, Inc.**, Irving, TX (US)

U.S. PATENT DOCUMENTS

(*) Notice: Subject to any disclaimer, the term of this patent is extended or adjusted under 35 U.S.C. 154(b) by 0 days.

This patent is subject to a terminal disclaimer.

136,128 A	2/1873	Bralley
994,746 A	6/1911	Haynes
996,743 A	7/1911	Yancey
1,113,057 A	10/1914	Schumann
1,787,601 A	1/1931	Swanberg
2,087,503 A	7/1937	Clemmons

(Continued)

(21) Appl. No.: **16/686,328**

OTHER PUBLICATIONS

(22) Filed: **Nov. 18, 2019**

U.S. Pat. No. 6,823,889, File History (2004-2005) Great-Great-Great-Great Grandparent Patent to this Application.

Related U.S. Application Data

(Continued)

(63) Continuation of application No. 14/856,901, filed on Sep. 17, 2015, now Pat. No. 10,519,639, which is a continuation of application No. 14/164,424, filed on Jan. 27, 2014, now Pat. No. 9,139,993, which is a continuation of application No. 13/346,355, filed on Jan. 9, 2012, now Pat. No. 8,650,671, which is a continuation of application No. 12/786,904, filed on May 25, 2010, now Pat. No. 8,104,105, which is a continuation of application No. 10/958,797, filed on Oct. 5, 2004, now Pat. No. 7,743,436, which is a continuation-in-part of application No. 10/798,606, filed on Mar. 11, 2004, now Pat. No. 6,823,889.

Primary Examiner — Tuan N Nguyen

(74) *Attorney, Agent, or Firm* — Thomas Horstemeyer, LLP

(51) **Int. Cl.**
E03D 1/00 (2006.01)
E03D 1/34 (2006.01)
B23P 15/00 (2006.01)

(57) **ABSTRACT**

According to various embodiments, a toilet system includes a toilet fill valve and a bowl fill valve that is configured to attach directly to the toilet fill valve. The toilet fill valve can include a body having an extended portion that forms a bowl fill outlet port, a water inlet configured to couple to a water source, and a tank water outlet configured to output water to a toilet tank. The bowl fill valve can include a bowl fill valve inlet port that is configured to mate directly to the bowl fill outlet port of the body of the toilet fill valve, a bowl fill valve outlet port, a protrusion configured to insert into a recess of the toilet fill valve and retain the bowl fill valve to the toilet fill valve, a slot that is configured to receive an extension of the toilet fill valve, and a water flow adjustment handle.

(52) **U.S. Cl.**
CPC **E03D 1/34** (2013.01); **B23P 15/001** (2013.01)

14 Claims, 9 Drawing Sheets

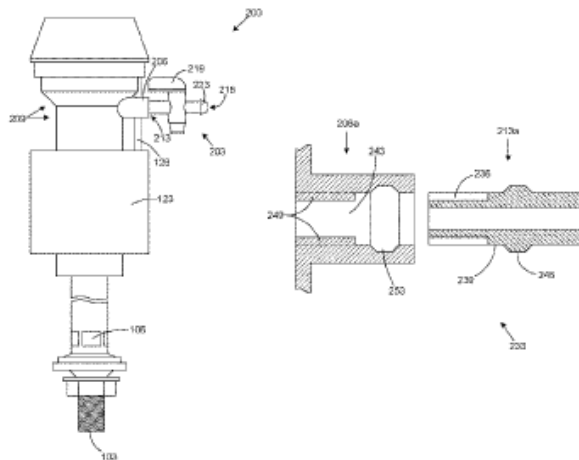

US 10,934,698 B1

Page 2

(56)

References Cited

U.S. PATENT DOCUMENTS

2,465,866 A	3/1949	Gaines	
2,512,176 A	6/1950	Shaffer	
2,736,037 A	2/1956	Hardie	
2,791,235 A	5/1957	Smith	
2,799,865 A	7/1957	Dufault	
3,040,769 A	6/1962	Lamb	
3,086,217 A *	4/1963	Barlow E03D 1/286 4/367
3,086,546 A	4/1963	Brown	
3,172,128 A	3/1965	Ducey	
3,321,972 A	5/1967	Goldtrap	
3,457,947 A	7/1969	Fitzgerald	
3,744,064 A	7/1973	Preston	
3,762,395 A	10/1973	Taylor	
3,782,686 A	1/1974	Cowie	
3,986,216 A	10/1976	Davis et al.	
3,994,628 A	11/1976	Kemper	
4,007,498 A	2/1977	Pearson	
4,017,916 A	4/1977	Pearson	
4,032,822 A	6/1977	Un	
4,090,532 A	5/1978	Story, Jr.	
4,100,928 A *	7/1978	Schoepe F16K 31/34 137/15.18
4,134,164 A	1/1979	Sanmartin Rial	
4,145,775 A	3/1979	Butler	
4,351,071 A	9/1982	Clar	
4,392,260 A	7/1983	Bensen	
4,420,845 A	12/1983	Antunez	
4,505,231 A	3/1985	Syler	
4,527,295 A	7/1985	Lacore	
4,700,413 A	10/1987	Lopez	
4,707,567 A	11/1987	Kawabe et al.	
4,764,996 A	8/1988	Pino	
4,770,388 A	9/1988	Carman	
4,793,588 A	12/1988	Laverty, Jr.	
4,898,124 A	2/1990	Granberg et al.	
4,918,764 A	4/1990	Haselswerdt et al.	
4,980,932 A	1/1991	Stemples	
5,007,452 A	4/1991	Antunez	
5,036,553 A	8/1991	Sanderson	
5,052,060 A	10/1991	Makita et al.	
5,083,323 A	1/1992	Cannan	
5,123,628 A	6/1992	Yu	
5,134,729 A	8/1992	Shaw	
5,228,152 A	7/1993	Fralely	
5,232,011 A	8/1993	Royalty	
5,245,710 A	9/1993	Haselswerdt et al.	

5,327,931 A	7/1994	Royalty et al.	
5,362,026 A	11/1994	Kobayashi et al.	
5,432,959 A	7/1995	Ellsworth et al.	
5,442,820 A	8/1995	Becker	
5,469,586 A	11/1995	Tsutsui et al.	
5,542,448 A	8/1996	Campbell et al.	
5,624,073 A	4/1997	Mueller et al.	
5,708,991 A	1/1998	DeMarco	
5,715,860 A	2/1998	Horad	
5,742,951 A	4/1998	Wright et al.	
5,775,366 A	7/1998	Ray et al.	
5,794,279 A	8/1998	Schwartz	
5,862,637 A	1/1999	Osmond	
5,926,868 A	7/1999	Bjerke	
6,047,725 A	4/2000	Gish et al.	
6,202,227 B1	3/2001	Gurowitz	
6,209,576 B1	4/2001	Davis	
6,263,519 B1	7/2001	Parsons et al.	
6,295,660 B1	10/2001	Schuster	
6,219,856 B1	11/2001	Alles	
6,385,788 B1	5/2002	Wasielewski	
6,409,221 B1	6/2002	Robinson et al.	
6,560,790 B2	5/2003	Saar et al.	
6,823,889 B1	11/2004	Schuster	
7,743,436 B1	6/2010	Schuster et al.	
8,104,105 B1	1/2012	Schuster et al.	
8,650,671 B1	2/2014	Schuster et al.	
9,103,105 B1	8/2015	Schuster et al.	
9,139,993 B1	9/2015	Schuster et al.	
10,519,639 B1 *	12/2019	Schuster E03D 1/34
2002/0092090 A1	7/2002	Johnson	
2002/0162166 A1	11/2002	Saar et al.	
2004/0199989 A1	10/2004	Trolio	

OTHER PUBLICATIONS

U.S. Pat. No. 7,743,436, File History (2004-2010) Great-Great-Grandparent Patent to this Application.
 U.S. Pat. No. 8,104,105, File History (2010-2012) Great-Great-Grandparent to this Application.
 U.S. Pat. No. 8,650,671 File History (2012-2014) Great-Grandparent to this Application.
 U.S. Pat. No. 9,139,993 File History (2014-2015) Grandparent to this Application.
 U.S. Pat. No. 9,103,105 File History (2014-2015) Sibling of the Grandparent to this Application.
 U.S. Appl. No. 14/856,901 File History (2015-2019) Parent to this Application.

* cited by examiner

U.S. Patent

Mar. 2, 2021

Sheet 1 of 9

US 10,934,698 B1

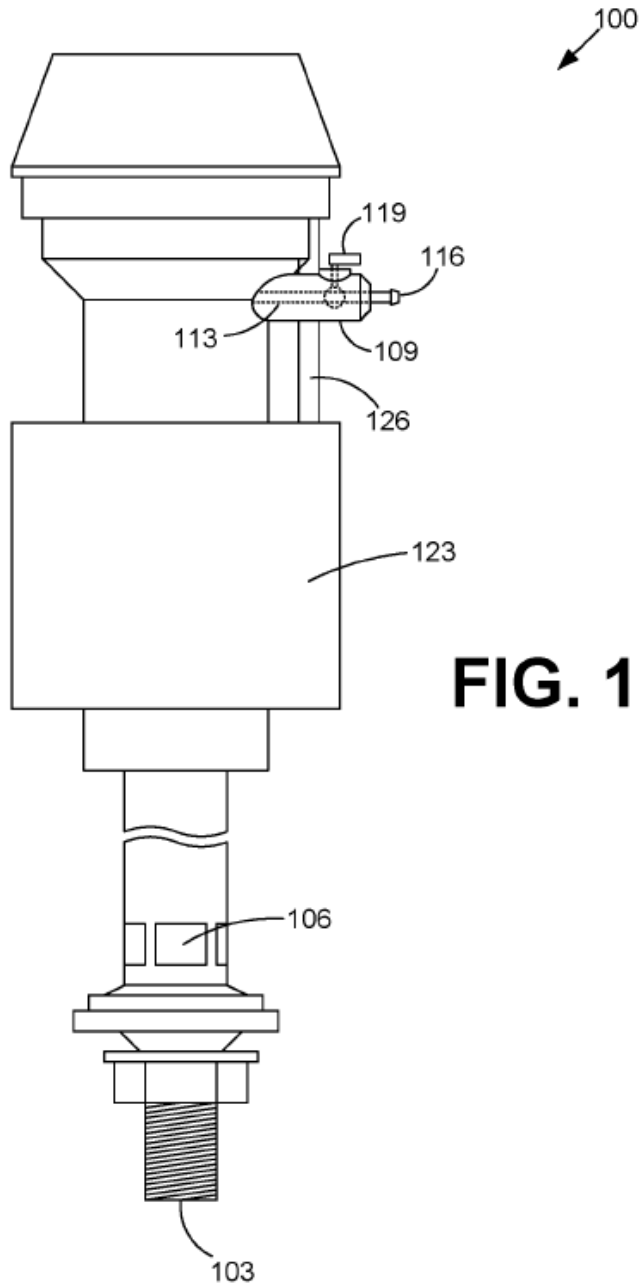

1
2
3
4
5
6
7
8
9
10
11
12
13
14
15
16
17
18
19
20
21
22
23
24
25
26
27
28

U.S. Patent

Mar. 2, 2021

Sheet 2 of 9

US 10,934,698 B1

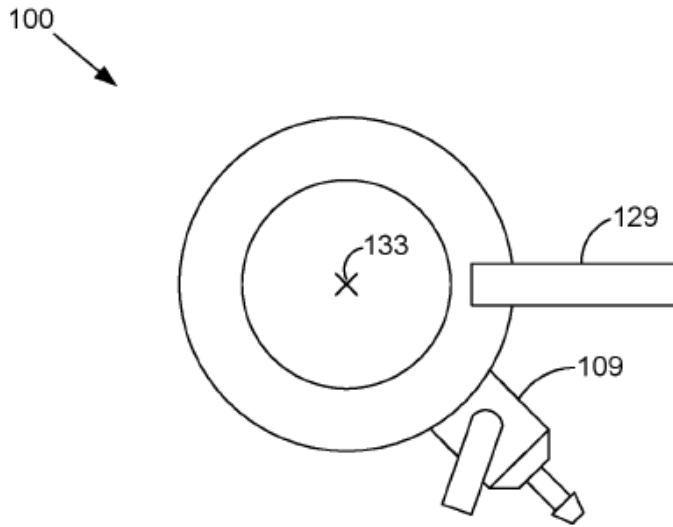

FIG. 2

U.S. Patent

Mar. 2, 2021

Sheet 3 of 9

US 10,934,698 B1

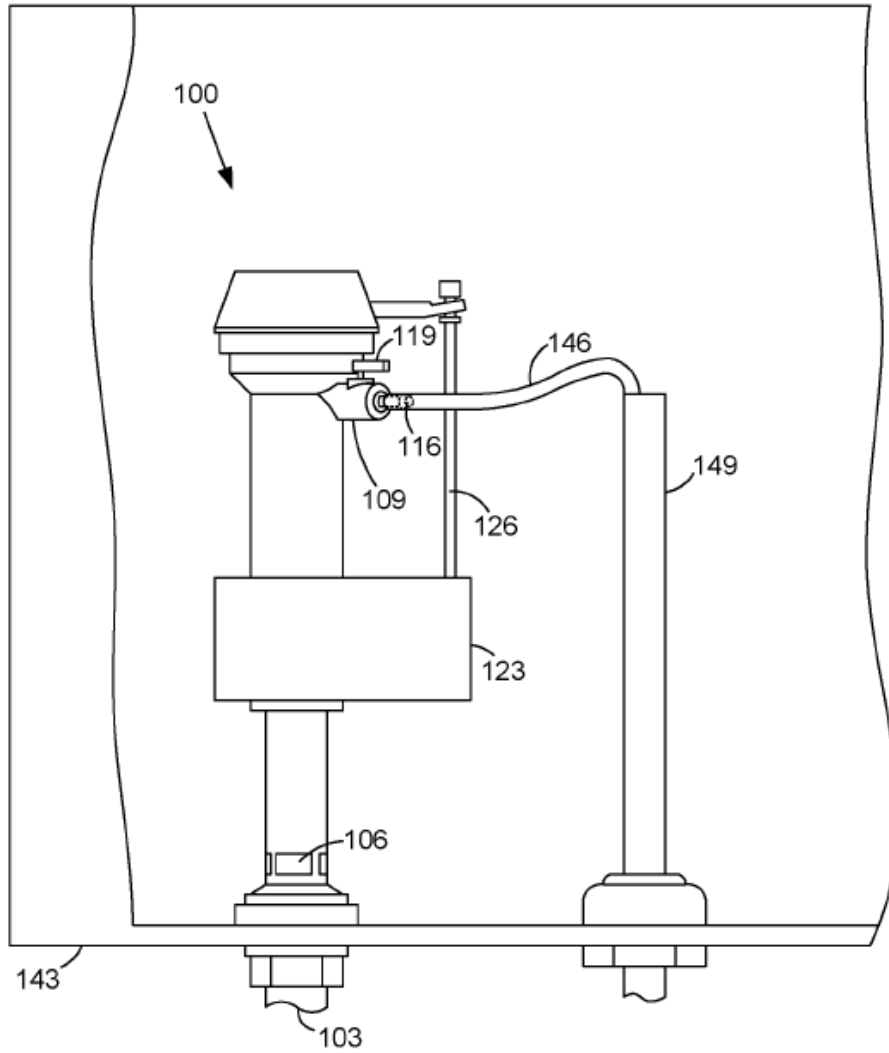

FIG. 3

U.S. Patent

Mar. 2, 2021

Sheet 4 of 9

US 10,934,698 B1

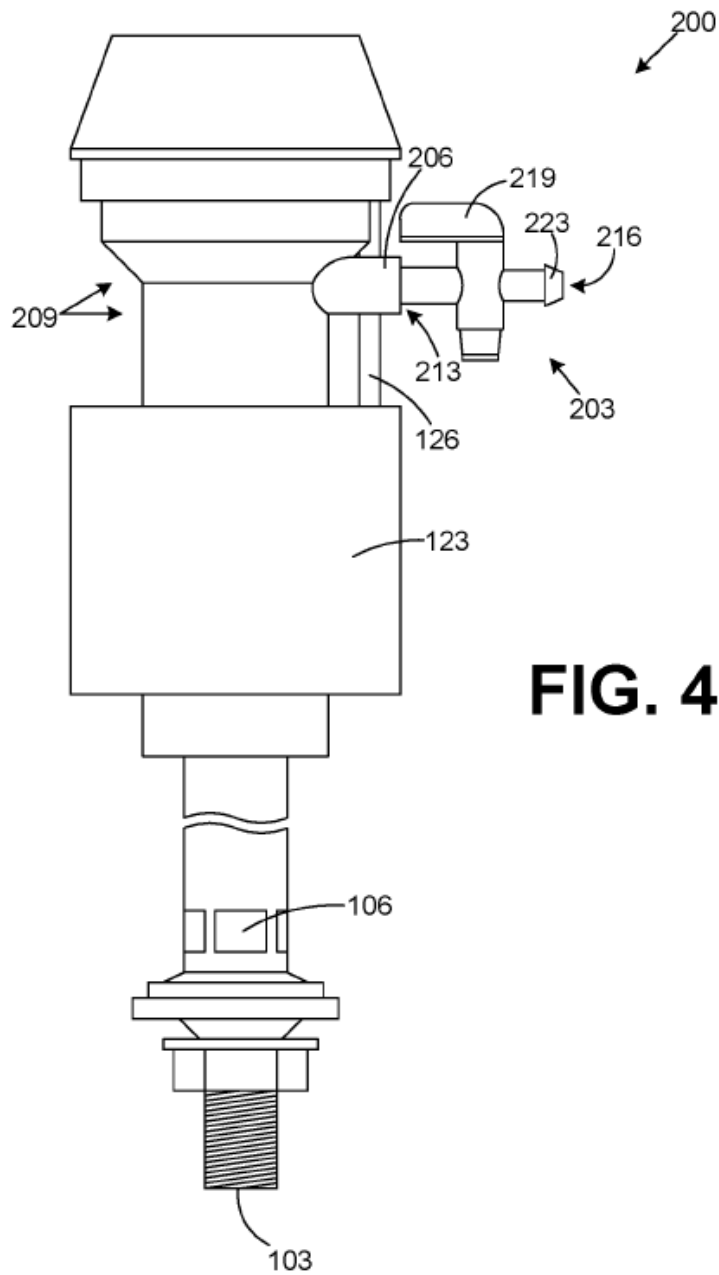

U.S. Patent

Mar. 2, 2021

Sheet 5 of 9

US 10,934,698 B1

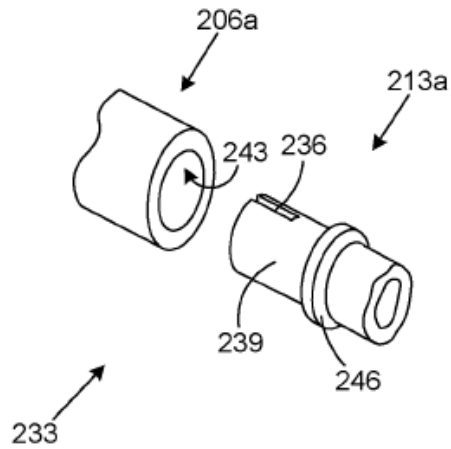

FIG. 5A

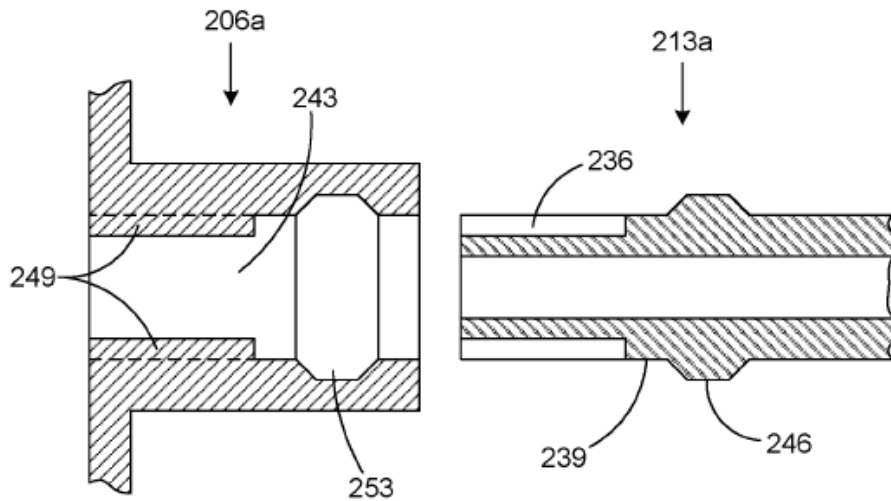

FIG. 5B

U.S. Patent

Mar. 2, 2021

Sheet 6 of 9

US 10,934,698 B1

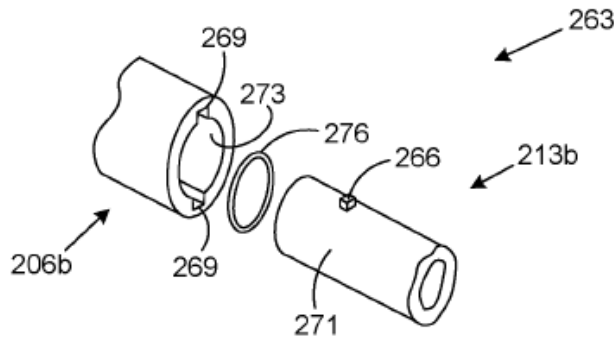

FIG. 6A

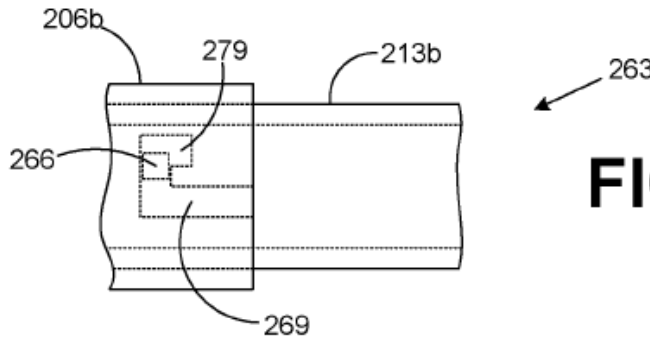

FIG. 6B

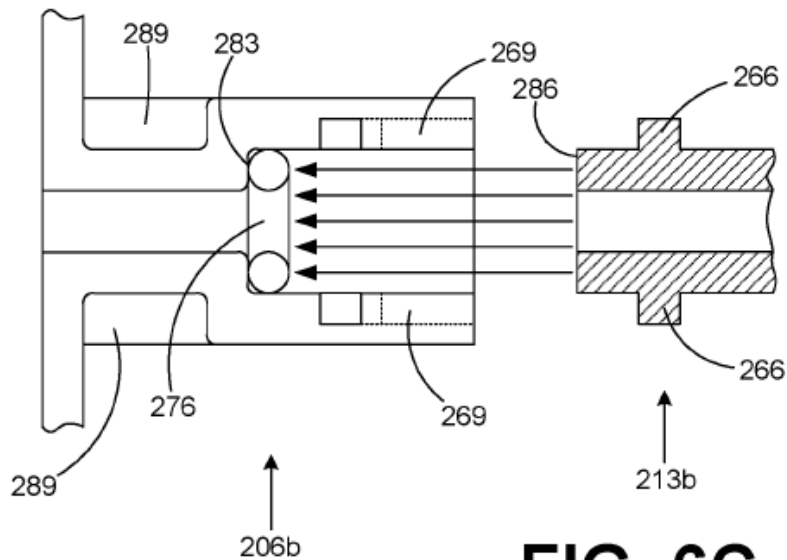

FIG. 6C

U.S. Patent

Mar. 2, 2021

Sheet 7 of 9

US 10,934,698 B1

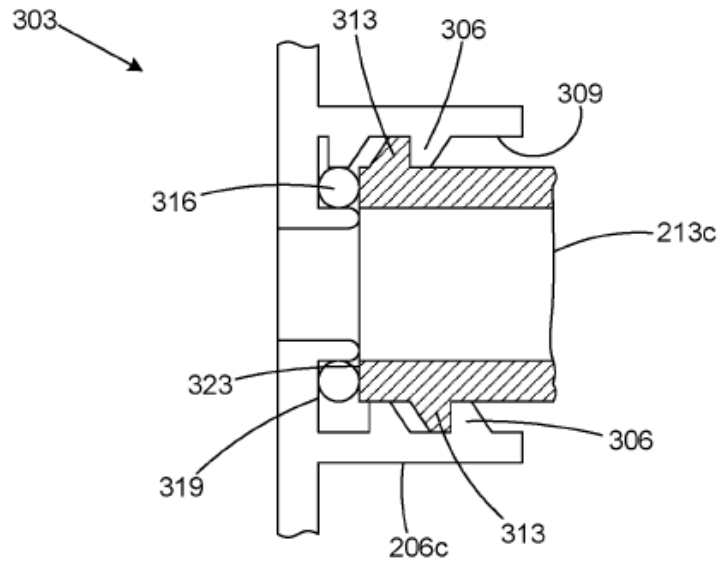

FIG. 7

U.S. Patent

Mar. 2, 2021

Sheet 8 of 9

US 10,934,698 B1

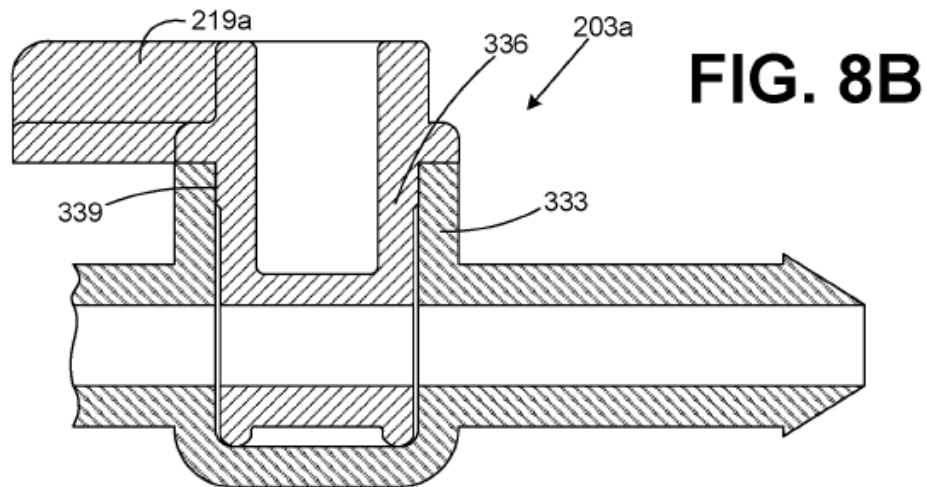
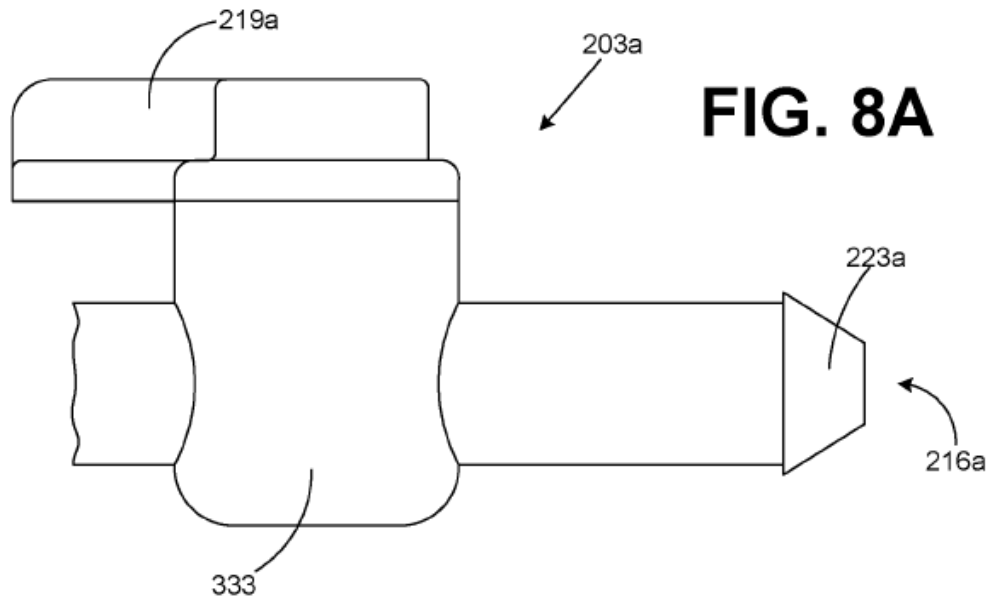

U.S. Patent

Mar. 2, 2021

Sheet 9 of 9

US 10,934,698 B1

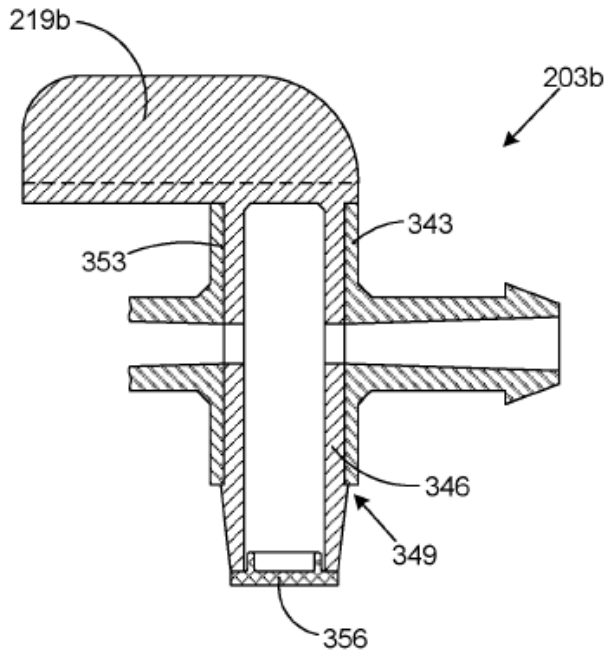
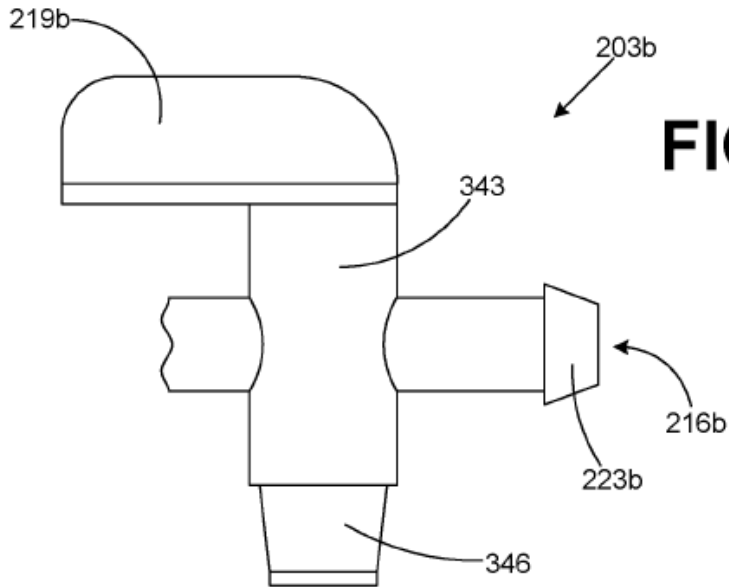

US 10,934,698 B1

1
TOILET VALVE

CROSS-REFERENCE TO RELATED APPLICATIONS

The present patent application is a continuation application of, and claims priority to, U.S. patent application Ser. No. 14/856,901 filed on Sep. 17, 2015 and titled "TOILET VALVE," which is a continuation application of, and claims priority to U.S. patent application Ser. No. 14/164,424 filed on Jan. 27, 2014 and titled "TOILET FILL VALVE," which is a continuation application of, and claims priority to U.S. patent application Ser. No. 13/346,355 filed on Jan. 9, 2012 and titled "TOILET FILL VALVE WITH ADJUSTABLE BOWL FILL FLOW," which is a continuation application of, and claims priority to, U.S. patent application Ser. No. 12/786,904 filed on May 25, 2010 and titled "TOILET FILL VALVE WITH ADJUSTABLE BOWL FILL FLOW," which is a continuation application of, and claims priority to, U.S. application Ser. No. 10/958,797 filed on Oct. 5, 2004 and titled "TOILET FILL VALVE WITH ADJUSTABLE BOWL FILL FLOW," which is a continuation-in-part application of, and claims priority to, U.S. patent application Ser. No. 10/798,606 filed on Mar. 11, 2004 and titled "TOILET FILL VALVE WITH ADJUSTABLE BOWL FILL FLOW."

BACKGROUND

A toilet fill valve in a toilet typically includes a water outlet that provides water for refilling a toilet bowl during a flush cycle. Unfortunately, the water flowing out of such conventional water outlets to fill a toilet bowl provide much more water than is necessary to fill the average toilet bowl. Consequently, much of the water that flows into a toilet bowl during the average flush cycle is lost down the drain. This translates into a loss of millions of gallons of water each year.

BRIEF DESCRIPTION OF THE SEVERAL VIEWS OF THE DRAWINGS

The invention can be understood with reference to the following drawings. The components in the drawings are not necessarily to scale. Also, in the drawings, like reference numerals designate corresponding parts throughout the several views.

FIG. 1 is a drawing of a side view of a toilet fill valve according to an embodiment of the present invention;

FIG. 2 is a drawing of a top view of the toilet fill valve of FIG. 1;

FIG. 3 is a drawing of a cutaway view of a toilet tank within which the toilet fill valve of FIG. 1 is installed;

FIG. 4 is a drawing of a side view of a toilet fill valve according to an embodiment of the present invention;

FIGS. 5A and 5B are drawings that illustrate one example of a coupling of a bowl fill valve to the toilet fill valve of FIG. 4 according to an embodiment of the present invention;

FIGS. 6A, 6B, and 6C are drawings that illustrate another example of a coupling of a bowl fill valve to the toilet fill valve of FIG. 4 according to an embodiment of the present invention;

FIG. 7 is a drawing that illustrates still another example of a coupling of a bowl fill valve to the toilet fill valve of FIG. 4 according to an embodiment of the present invention;

FIGS. 8A and 8B are drawings that illustrate an example of a bowl fill valve that is coupled to the toilet fill valve of FIG. 4 according to an embodiment of the present invention; and

2

FIGS. 9A and 9B are drawings that illustrate another example of a bowl fill valve that is coupled to the toilet fill valve of FIG. 4 according to an embodiment of the present invention.

DETAILED DESCRIPTION

With reference to FIG. 1, shown is a toilet fill valve 100 according to an embodiment of the present invention. The toilet fill valve 100 includes a water inlet 103 at the bottom of the toilet fill valve 100 that is configured to be coupled to a water source outside of a toilet tank within which the toilet fill valve 100 is installed. The toilet fill valve 100 includes one or more water outlets 106 that are configured to supply water into a toilet tank within which the toilet fill valve 100 is installed. The toilet fill valve 100 may be, for example, a pilot style fill valve. However, it is understood that the toilet fill valve 100 may be any style of fill valve such as, for example, a ballcock valve, etc. The toilet fill valve 100 also includes a bowl fill valve 109 according to an embodiment of the present invention. The bowl fill valve 109 includes a bowl fill valve inlet 113 and a bowl fill valve outlet 116. In addition, the bowl fill valve 109 includes a handle 119 that facilitates a manual adjustment of the bowl fill valve 109.

The bowl fill valve 109 is integral with the toilet fill valve 100. In this respect, the term "integral" refers to the fact that the bowl fill valve 109 and the toilet fill valve 100 comprise a single structure. In this respect, the bowl fill valve 109 may be included within the body of the toilet fill valve 100 as a portion of the toilet fill valve 100 in a single piece construction. Specifically, the bowl fill valve 109 may be molded as a portion of the toilet fill valve 100 or it may be snapped or clamped into place, or it may be attached to the toilet fill valve 100 in some other manner, etc.

Within the toilet fill valve 100, the bowl fill valve inlet 113 is operatively coupled to the water inlet 103. In this respect, when the toilet fill valve 100 is open and water flows from the water inlet 103 to the water outlets 106 and into a toilet tank, an amount of water is also supplied to the bowl fill valve inlet 113 that flows through the bowl fill valve 109 and out the bowl fill valve outlet 116. By virtue of the manual setting of the handle 119 of the bowl fill valve 109, the flow of water through the bowl fill valve 109 is regulated. In this manner, the flow of water is regulated so that enough water flows out of the bowl fill valve 109 to fill a toilet bowl without wasting any water down a drain.

Thus, the bowl fill valve 109 is configured to supply an adjustable flow of water out of the bowl fill outlet 116 that is directed to a toilet bowl during a flush cycle of a toilet to fill the toilet bowl. The flow of water is adjusted so that just enough flows out of bowl fill valve 109 so as to fill the toilet bowl without wasting any water.

The toilet fill valve 100 includes a float 123 that is operatively coupled to an actuating arm (not shown) by a translating stem 126. The float 123 floats on the water within a toilet tank and, depending on the location of the float 123 along the toilet fill valve 100, the toilet fill valve 100 is open or closed as can be appreciated by those with ordinary skill in the art. The bowl fill valve 109 and the actuating arm (not shown) are each located on the toilet fill valve 100 so as to prevent any interference between the bowl fill valve 109 and the translational stem 126 or the actuating arm as will be discussed.

According to an embodiment of the present invention, the bowl fill valve 109 may include a number of biased positions. In this respect, the movement of the handle 119 may cause the bowl fill valve 109 to move from one predefined

1
2
3
4
5
6
7
8
9
10
11
12
13
14
15
16
17
18
19
20
21
22
23
24
25
26
27
28

US 10,934,698 B1

3

4

biased position to other predefined biased positions. In this respect, various mechanisms such as tabs, snaps, or other position biasing structures may be employed. The biased positions of the bowl fill valve 109 help ensure that the bowl fill valve 109 remains in a given setting selected by a user by a manual manipulation of the handle 119 during the normal course of operation of the toilet fill valve 100. Thus, by virtue of the biased positions, the bowl fill valve 109 is prevented from moving out of a desired position set by a user over a long period of use due to vibration and other factors as can be appreciated by those with ordinary skill in the art.

The bowl fill valve 109 may be, for example, a ball valve, a gate valve, a globe valve, a plug valve, a diaphragm valve, a butterfly valve, a needle valve, a sliding gate, a quick turn valve, a knife valve or any other appropriate type of valve as can be appreciated by those with ordinary skill in the art.

To operate the toilet fill valve 100, the toilet fill valve 100 is first installed within a toilet tank. When a toilet is flushed and the tank is drained, the float 123 moves downward along the toilet fill valve 100 and, consequently, the toilet fill valve 100 opens to allow water to flow from the water inlet 103 and out the water outlets 106 into a toilet tank. At the same time, water flows into the bowl fill valve inlet 113 and out the bowl fill valve outlet 116 through the bowl fill valve 109. Based on the setting of the handle 119, the bowl fill valve 109 determines the precise flow rate of the water that flows out the bowl fill valve outlet 116. A tube is typically employed to direct the water flowing out the bowl fill valve outlet 116 to an overflow tube in the toilet tank. In this respect, the water flowing out the bowl fill valve outlet 116 refills the toilet bowl of the respective toilet.

Referring next to FIG. 2, shown is a top view of the toilet fill valve 100 according to an embodiment of the present invention. In this respect, the actuating arm 129 of the toilet fill valve 100 is seen with respect to the bowl fill valve 109. The actuating arm 129 is coupled to the float by way of the translational stem 126 (FIG. 1). In this respect, the actuating arm 129 extends in an orthogonal direction relative to a longitudinal axis 133 of the toilet fill valve 100. The longitudinal axis 133 is centered in the toilet fill valve 100 along the length of the toilet fill valve 100. Also, the bowl fill valve 109 extends in an orthogonal direction relative to the longitudinal axis 133 of the toilet fill valve 100. In order to prevent interference between the bowl fill valve 109 and the translational stem 126 or the actuating arm 129, the actuating arm 129 is angularly offset relative to the bowl fill valve 109 as shown. In this respect, the translational stem 126 is coupled to the free end of the actuating arm 129. By virtue of the angular offset between the bowl fill valve 109 and the actuating arm 129, the operation of the bowl fill valve 109 does not interfere with the operation of the toilet fill valve 100 itself by virtue of the fact that the float 123 (FIG. 1) can move freely with the movement of the translational stem 126 in order for proper operation of the toilet fill valve 100.

With reference to FIG. 3, shown is the toilet fill valve 100 as installed within a toilet tank 143 according to an embodiment of the present invention. In this respect, the toilet fill valve 100 includes the water inlet 103 that is coupled to a water source outside of the toilet tank 143. The toilet fill valve 100 also includes one or more water outlets 106 that direct a flow of water into the toilet tank 143 during the operation of a flush cycle. The bowl fill valve 109 includes the bowl fill valve inlet (not shown) and the bowl fill valve outlet 116, where the bowl fill valve inlet is operatively coupled to the water inlet 103 as described above. Also, the

bowl fill valve 109 is integrated with the body of the toilet fill valve 100 as described above.

A tube 146 is coupled to the bowl fill valve outlet 116 and is directed into the overflow tube 149 of the toilet tank 143. The tube 146 directs water that flows out of the bowl fill valve outlet 116 into the overflow tube 149 and refills the toilet bowl associated with the toilet tank 143 as can be appreciated by those with ordinary skill in the art. The bowl fill valve 109 is configured to supply the adjustable flow of water out the bowl fill valve outlet through the tube 146 and into the overflow tube 149 for filling the toilet bowl during the flush cycle of the toilet. In this respect, no pressure is seen within the tube 146. Specifically, the fact that the bowl fill valve 109 is integral with the toilet fill valve 100 prevents the creation of a pressure head in the tube 146 as would be the case if the bowl fill valve 109 were included in the middle of the tube 146. The fact that a pressure head is not created in any portion of the tube 146 prevents the tube 146 from working its way off of the bowl fill valve outlet 116 over time.

When installed, the bowl fill valve 109 is calibrated for the particular flush cycle of the toilet within which the toilet fill valve 100 is installed. To calibrate the bowl fill valve 109, a user first determines the water level in the toilet bowl when the toilet bowl is full of water. This gives the user a starting and an ending point for determining when the toilet bowl of the respective toilet is full. Next, the bowl fill valve handle 119 is adjusted so that the bowl fill valve 109 is placed in a predefined position that allows a predefined flow of water to refill the toilet bowl. In this manner, one adjusts the actual flow of water that refills the toilet bowl. Thereafter, the user flushes the toilet itself. Next, the user determines if the flow of water into the toilet bowl by virtue of the adjustments made to the bowl fill valve 109 is adequate to refill the toilet bowl during the flush cycle. This may be determined, by identifying whether the level of the water in the toilet bowl reaches the full level determined at the beginning of the bowl fill valve calibration above.

The flow of water from the bowl fill valve 109 should be set so as to ensure that the water level in the toilet bowl reaches the full level at about the same time that the flush cycle ends. In other words, the level of water in the toilet bowl should reach its highest level at the same time that the flush cycle ends. This prevents any water from being lost down the drain associated with the toilet.

If the amount of water that flows into the toilet bowl is inadequate to refill the toilet bowl during the flush cycle as described above, then one should repeat the steps of adjusting the bowl fill valve, flushing the toilet, and then once again determining if the flow of water into the toilet bowl is adequate to refill the toilet bowl during a flush cycle.

Ultimately, during use of the toilet that includes the toilet fill valve 100 and the toilet tank 143, a user flushes the toilet and a predetermined flow of water exits the bowl fill valve outlet 116 and is directed into the toilet bowl. After the toilet tank has drained during the flush cycle, a flapper closes in the toilet tank and the toilet tank refills. During the refilling of the tank, the water supplied by the bowl fill valve 109 fills the toilet bowl itself. The amount of water supplied by the bowl fill valve in the time it takes to refill the toilet tank should be approximately equal to the amount of water needed to fill the toilet bowl. By virtue of the fact that the bowl fill valve 109 is integrated within the toilet fill valve 100, a pressure head is prevented from being created due to any potential pinching of the tube 146 or other similar adjustment mechanism.

US 10,934,698 B1

5

With reference to FIG. 4, shown is a toilet fill valve 200 according to another embodiment of the present invention. The toilet fill valve 200 includes the same water inlet 103 and the water outlets 106 as the toilet fill valve 100 (FIG. 1). The toilet fill valve 200 also includes the float 123 and the translational stem 126 as was described with reference to the toilet fill valve 100. In addition, the toilet fill valve 200 includes a bowl fill valve 203 that is integral with the toilet fill valve 200 as will be described. As stated above, the term "integral" refers to the fact that the bowl fill valve 203 and the toilet fill valve 200 comprise a single structure. In this embodiment, the bowl fill valve 203 is a separate component that is attached to the body of the toilet fill valve 200, thereby forming the integral, single structure.

The toilet fill valve 200 also includes a bowl fill outlet port 206 that radially extends from a portion of a body 209 of the toilet fill valve 200. In this respect, the bowl fill outlet port is operatively coupled to the water inlet 103. In particular, when the toilet fill valve 200 is in an "on" state, water that flows in the water inlet 103 flows out of both the water outlets 106 and the bowl fill outlet port 206. The water flowing out of the bowl fill outlet port 206 flows through the bowl fill valve 203 as will be described.

The bowl fill valve 203 includes a bowl fill valve inlet port 213 and a bowl fill valve outlet port 216. The bowl fill valve inlet port 213 is compatible with the bowl fill outlet port 206, where the bowl fill valve inlet port 213 is coupled to the bowl fill outlet port 206 when the bowl fill valve 203 is coupled or affixed to the toilet fill valve 200. The bowl fill valve inlet port 213 is compatible with the bowl fill outlet port 206 in the sense that both the bowl fill valve inlet port 213 and the bowl fill outlet port 206 comprise various structures that couple together when the bowl fill valve 203 is connected to the bowl fill outlet port 206 as will be described. In particular, various embodiments of the coupling between the bowl fill valve inlet port 213 and the bowl fill outlet port 206 are described herein.

The bowl fill valve 203 also includes a handle that may be adjusted by hand to adjust a flow of water through the bowl fill valve 203 during a flush operation of a toilet in which the toilet fill valve 200 is installed. Typically, the handle 219 is initially adjusted to a desired position when the toilet fill valve 200 is installed and generally remains in such position for the continued operation of the toilet fill valve 200. During the life cycle of the bowl fill valve 203, it may be possible that the bowl fill valve 203 is adjusted to take into account various changes in the operation of the toilet fill valve 200 such as, for example, changes in pressure or other operational changes.

The bowl fill valve 203 also includes a nipple 223. The nipple 223 is adapted to mate with a tube that extends from the bowl fill valve outlet port 216 to the overflow tube 149 (FIG. 3) in a manner similar to that as shown in FIG. 3 with respect to the tube 146 (FIG. 3) that extends from the nipple 116 (FIG. 3) to the overflow tube 149 (FIG. 3). The bowl fill valve 203 extends beyond the bowl fill outlet port 206 in a radial direction with respect to the portion of the body 209 of the toilet fill valve 200.

In some embodiments, the bowl fill outlet port 206 may comprise a female receptacle and, correspondingly, the bowl fill valve inlet port 213 may comprise a male end compatible with the female receptacle. Alternatively, the bowl fill valve inlet port 213 may comprise a female receptacle and the bowl fill outlet port 206 may comprise a male end compatible with such female receptacle.

The toilet fill valve 200 further includes an actuating arm (not shown) that extends in a radial direction that is orthogo-

6

nal relative to a longitudinal axis of the toilet fill valve 200 in a manner similar as that described with reference to the toilet fill valve 100 (FIG. 1). The longitudinal axis is defined as an axis that runs from the water inlet 103 through the body 209 of the toilet fill valve 200 and out the top of the toilet fill valve 200. In one embodiment, the bowl fill valve 203 extends radially in an orthogonal direction relative to such longitudinal axis of the toilet fill valve 200. Also, in one embodiment, the actuating arm is angularly offset relative to the bowl fill valve 203 to prevent interference between the bowl fill valve 203 and the translational stem 126 that extends from the float 123 to a free end of the actuating arm. This allows the float 123 to move up and down and to engage the actuating arm during the normal operation of the toilet fill valve 200 during various flush cycles.

In addition, the bowl fill valve 203 may be constructed with a number of biased positions that help prevent the bowl fill valve 203 from moving out of adjustment over time when the force of pressure develops therein. Also, the biased positions aid a user in actual adjustment of the bowl fill valve 203 as can be appreciated.

The toilet fill valve 200 provides an advantage in that the body 209 of the toilet fill valve 200 may be constructed with the bowl fill outlet port 206 using a molding process that is much less complex than attempting to mold the entire bowl fill valve 203 within the structure of the body 209 as a single molded construction as was described with reference to one embodiment of the toilet fill valve 100. In this regard, the bowl fill valve 203 may be constructed as a separate component to the body 209 of the toilet fill valve 200 and assembled for distribution to end users.

Due to the fact that the bowl fill valve 203 is affixed to the toilet fill valve 200 through the coupling of the bowl fill outlet port 206 with the bowl fill valve inlet port 213, then a pressure head that develops within the bowl fill valve 203 due to the adjustment of the handle 219 during operation of the toilet fill valve 200 will not cause the bowl fill valve 203 to fall off of the toilet fill valve 200. Thus, when the toilet fill valve 200 is installed in a toilet tank 143, a user may adjust the opening of the bowl fill valve 203 by adjusting the handle 219 until a desired flow of water flows out of the bowl fill valve outlet port 216 into a tube and into the overflow tube 149 of a toilet. This flow of water is typically established to refill a toilet bowl of a toilet. In this regard, the flow of the water into the overflow tube 149 that refills the toilet bowl during a toilet flush operation may be regulated or adjusted so as to minimize or eliminate the amount of water that is lost down the drain of a toilet due to over filling of the toilet bowl during a flush cycle of a toilet. In one embodiment, the bowl fill valve 203 is adjusted until the filling of the toilet bowl of the toilet coincides with the end of the flush cycle, thereby resulting in little or no loss of water.

Referring next to FIG. 5A, shown is a coupling 233 between one embodiment of the bowl fill outlet port 206, denoted herein as bowl fill outlet port 206a, and an embodiment of the bowl fill valve inlet port 213, denoted herein as bowl fill valve inlet port 213a. The bowl fill valve inlet port 213a includes a slot 236 in a side wall 239. The bowl fill outlet port 206a comprises a rib (not shown) that extends from a side wall 243 that is inserted into the slot 236 when the bowl fill valve inlet port 213a is inserted into the bowl fill outlet port 206a. The mating of the slot 236 with the rib prevents the rotation of the bowl fill valve 203 with respect to the bowl fill outlet port 206a when the bowl fill valve inlet port 213a is inserted into the bowl fill outlet port 206a. Alternatively, there may be a number of slots 236 in the side

US 10,934,698 B1

7

wall 239 of the bowl fill valve inlet port 213a and a corresponding number of ribs extending from the side wall 243 of the bowl fill outlet port 206a.

The bowl fill valve inlet port 213a also includes an annular protrusion 246 that extends from the side wall 239 of the bowl fill valve inlet port 213a. Correspondingly, an annular groove (not shown) in the side wall 243 of the bowl fill outlet port 206a is provided that mates up with the annular protrusion 246 when the bowl fill valve inlet port 213a is inserted into the bowl fill outlet port 206a. In this respect, the annular protrusion 246 is snap fit into the annular groove (not shown), thereby affixing the bowl fill valve 203 to the bowl fill outlet port 206a.

Turning then to FIG. 5B, shown is a cutaway view of the coupling 233 between the bowl fill outlet port 206a and the bowl fill valve inlet port 213a according to an embodiment of the present invention. In this respect, the bowl fill outlet port 206a is depicted with two ribs 249 extending from the side wall 243 within the bowl fill outlet port 206a. Also, the bowl fill outlet port 206a includes the annular groove 253 into which the annular protrusion 246 snaps when the bowl fill valve inlet port 213a is inserted into the bowl fill outlet port 206a. In this respect, the mating of the annular protrusion 246 with the annular groove 253 fixes the bowl fill valve 203 to the bowl fill outlet port 206a. In this respect, the bowl fill valve 203 becomes an integral portion of the toilet fill valve 200.

Also, the fit between the annular protrusion 246 is a snug fit that forms a seal between the bowl fill outlet port 206a and the bowl fill valve inlet port 213a that prevents the leakage of water from the coupling 233 during a flush cycle. Alternatively, a snug fit may occur between other mating surfaces of the bowl fill outlet port 206a and the bowl fill valve inlet port 213a that prevents leakage of water from the coupling 233.

With reference to FIGS. 5A and 5B, even though the slots 236 are depicted as being formed within the side wall 239 of the bowl fill valve inlet port 213 and the ribs 249 extend from the side wall 243 within the bowl fill outlet port 206, it is possible that this arrangement may be reversed where the slots 236 are formed in the side wall 243 of the bowl fill outlet port 206a and the ribs 249 extend from the side wall 239 of the bowl fill valve inlet port 213a. In addition, the annular groove 253 may be created in the side wall 239 of the bowl fill valve inlet port 213 and the annular projection 246 may extend inward from the side wall 243 within the bowl fill outlet port 206 in a reverse arrangement than that shown with reference to FIG. 5B.

Referring next to FIGS. 6A, 6B, and 6C, shown is a coupling 263 between another embodiment of the bowl fill outlet port 206, denoted herein as bowl fill outlet port 206b, and another embodiment of the bowl fill valve inlet port 213, denoted herein as bowl fill valve inlet port 213b. The bowl fill valve inlet port 213b includes at least two locking ears 266 that mate with corresponding locking grooves 269 in the bowl fill outlet port 206b. In particular, the locking ears 266 extend from a side wall 271 of the bowl fill valve inlet port 213b. The locking grooves 269 are disposed in the side wall 273 of the bowl fill outlet port 206b. When the bowl fill valve 203 is inserted and twisted into the bowl fill outlet port 206b, each of the locking ears 266 is situated in a locking position of one of the locking grooves 269 as will be described. The coupling 263 further comprises a sealing ring 276 that may be, for example, a rubber O-ring or other type of sealing ring. The sealing ring 276 is compressed between an end of the bowl fill valve inlet port 213b and a seat within the bowl fill outlet port 206b as we described. While at least

8

two locking ears 266 and corresponding locking grooves 269 are shown, it is possible that a design may be employed that comprises a single locking ear 266 and a single corresponding locking groove 269.

With reference to FIG. 6B, shown is a portion of the bowl fill valve inlet port 213b and the bowl fill outlet port 206b as the bowl fill valve inlet port 213b is inserted into the bowl fill outlet port 206b and is partially rotated such that the locking ears 266 are almost located in the locking positions 279. In this respect, each of the locking grooves 269 is a "J" formation. The J formation of the locking grooves 269 allows the locking ears 266 to slide down and around the partial loop of the J and seat in the locking position 279 such that the sealing ring 276 exerts a force against the end of the bowl fill valve inlet port 213b, thereby pushing the locking ears 266 into the locking positions 279 of the locking grooves 269 and holding the locking ears 266 in place. This ensures that the bowl fill valve 203 remains coupled to the bowl fill outlet port 206b.

With reference to FIG. 6C, shown is a cutaway view of the coupling 263 between the bowl fill outlet port 206b and the bowl fill valve inlet port 213b. In this respect, the bowl fill valve inlet port 213b is inserted into the bowl fill outlet port 206b in a manner such that the locking ears 266 mate with the locking grooves 269. When the locking ears 266 reach the bottom of the "J" of the locking grooves 269, then the bowl fill valve 203 is rotated so that the locking ears 266 may be seated in the locking positions 279.

The sealing ring 276 is seated against a portion of the bowl fill outlet port 206b. In one embodiment, this portion is a seating face 283 of the bowl fill outlet port 206b. Also, a portion of the bowl fill valve inlet port 213b is mated against the sealing ring 276. In one embodiment, this portion of the bowl fill valve inlet port 213b is an end face 286 such that the sealing ring is clamped between the seating face 283 and the end face 286 when the bowl fill valve inlet port 213b is inserted fully into the bowl fill outlet port 206b. The clamping or compression of the sealing ring 276 pushes the locking ears 266 into the locking position 279 of the locking grooves 269 once the bowl fill valve 203 is rotated accordingly. In this respect, the compressive force of the sealing ring 276 helps keep the bowl fill valve inlet port 213b of the bowl fill valve 203 mated with the bowl fill outlet port 206b. Also, the sealing ring 276 forms a seal between the bowl fill outlet port 206b and the bowl fill valve inlet port 213b that prevents leakage of water from the coupling 263 between the bowl fill outlet port 206b and the bowl fill valve inlet port 213b.

The locking positions 279 of the locking grooves and the locking ears 266 are located such that when the bowl fill valve 203 is rotated thereby positioning the locking ears 266 in the locking positions 279, the bowl fill valve 203 is substantially upright. In addition, the bowl fill outlet port 206b includes structural ribs 289 that provide greater structural stability for the bowl fill outlet port 206b and its attachment to the portion of the body 209 of the toilet fill valve 200 (FIG. 4). Alternatively, the bowl fill outlet port 206b may be attached without the structural ribs 289. In addition, it may be the case that the locking ears 266 extend inward from the side wall 273 of the bowl fill outlet port 206b and that the locking grooves 269 be situated within the side wall 271 of the bowl fill valve inlet port 213b.

Referring next to FIG. 7, shown is a cutaway view of a coupling 303 between a third embodiment of the bowl fill outlet port 206, denoted herein as bowl fill outlet port 206c and the bowl fill valve inlet port 213, denoted herein as bowl fill valve inlet port 213c. In this respect, the bowl fill outlet

1
2
3
4
5
6
7
8
9
10
11
12
13
14
15
16
17
18
19
20
21
22
23
24
25
26
27
28

US 10,934,698 B1

9

port 206c includes a first thread 306 disposed on a side wall 309 of the bowl fill outlet port 206c. A second thread 313 is disposed on a side wall of the bowl fill valve inlet port 213c that engages the first thread 306 disposed in the side wall of the bowl fill outlet port 206c. The bowl fill valve inlet port 213c is coupled to the bowl fill outlet port 206c by way of the first and second threads 306 and 313. Specifically, the bowl fill valve 203 may be screwed onto the bowl fill outlet port 206c by virtue of the threads 306 and 313. When the bowl fill valve inlet port 213c is screwed into the bowl fill valve outlet port 206c, a sealing ring 316 is clamped between portions of the bowl fill valve inlet port 213c and the bowl fill outlet port 206c such as a seating face 319 of the bowl fill outlet port 206c and an end face 323 of the bowl fill valve inlet port 213c. In this respect, a seal is formed between the bowl fill outlet port 206c and the bowl fill valve inlet port 213c. Alternatively, the threads 306 and 313 may be specified so as to form an adequate seal between the bowl fill valve outlet port 206c and the bowl fill valve inlet port 213c for purposes of preventing leakage. As an additional alternative, the seating face 319 and the end face 323 or other portions of the bowl fill valve inlet port 213c and the bowl fill outlet port 206c may be compressed together to form a seal to prevent leakage. Alternatively, the bowl fill outlet port 206c and the bowl fill valve inlet port 213c may be designed to include mating surfaces that perform a friction seal as can be appreciated.

Referring next to FIG. 8a, shown is one embodiment of the bowl fill valve 203, denoted herein as bowl fill valve 203a according to an embodiment of the present invention. The bowl fill valve 203a includes a handle 219a and a valve body 333. The bowl fill valve 203a includes the bowl fill valve outlet port 216a and the bowl fill valve inlet port (not shown) the bowl fill valve outlet port 216a includes a nipple 223a.

Referring then to FIG. 8b, shown is a cutaway view of the bowl fill valve 203a according to an embodiment of the present invention. In this respect, the valve body 333 forms a cavity within which a valve 336 is inserted as shown. A line contact 339 is formed between surfaces of the valve body 333 and the valve 336 so as to both hold the valve 336 within the cavity that is formed by the valve body 333 and to form a seal between the valve body 333 and the valve 336 to prevent water leakage. As seen, the valve 336 is integrated with the handle 219a in a single piece construction, although multiple piece construction may be employed.

With reference to FIGS. 9a and 9b, shown is a second embodiment of the bowl fill valve 203, denoted herein as bowl fill valve 203b according to an embodiment of the present invention. The bowl fill valve 203b includes a valve body 343 within which is inserted a valve 346. The bowl fill valve 203b further comprises the bowl fill valve outlet port 216b and a bowl fill valve inlet port (not shown). The bowl fill valve outlet port 216b includes a nipple 223b. The bowl fill valve 203b further includes a handle 219b for manual adjustment of the bowl fill valve 203b.

Referring next to FIG. 9b, shown is a cutaway view of the bowl fill valve 203b according to an embodiment of the present invention. As shown, the valve 346 is inserted into the valve body 343. A snap fit 349 affixes the valve 346 within the valve body 343. A seal is formed by virtue of an interference fit 353 between a surface of the valve 346 and an inner surface of the valve body 343. The bottom of the cavity within the valve 346 is closed by a cap 356 that may be spin welded onto the valve 346 after the valve is inserted into the valve body 343.

10

In addition, referring back to FIG. 4, other types of couplings may be employed between the bowl fill outlet port 206 the bowl fill valve inlet port 213. For example, the bowl fill outlet port 206 the bowl fill valve inlet port 213 may be configured to facilitate a compression fitting there between. Also, other snap fit and sealing configurations may be employed beyond those specifically described herein.

Although the invention is shown and described with respect to certain embodiments, it is obvious that equivalents and modifications will occur to others skilled in the art upon the reading and understanding of the specification. The present invention includes all such equivalents and modifications, and is limited only by the scope of the claims.

What is claimed is:

1. A toilet system, comprising:

a toilet fill valve that comprises:

a body comprising an extended portion that forms a bowl fill outlet port;

a water inlet configured to couple to a water source; and a tank water outlet configured to output water to a toilet tank;

a bowl fill valve configured to attach directly to the body of the toilet fill valve, the bowl fill valve comprising:

a bowl fill valve inlet port configured to mate directly to the bowl fill outlet port of the body of the toilet fill valve;

a bowl fill valve outlet port;

a protrusion configured to insert into a recess of the toilet fill valve and retain the bowl fill valve to the toilet fill valve, the protrusion being configured to snap fit into the recess;

a water flow adjustment handle; and

a slot configured to receive an extension of the toilet fill valve and prevent rotation of the bowl fill valve relative to the toilet fill valve; and

a tube configured to attach directly to the bowl fill valve outlet port of the bowl fill valve.

2. The toilet system of claim 1, wherein the bowl fill outlet port comprises a male end, and wherein the bowl fill valve inlet port comprises a female receptacle for the male end of the bowl fill outlet port.

3. The toilet system of claim 1, wherein the protrusion of the bowl fill valve is an annular protrusion located on a bowl fill valve side wall of the bowl fill valve, wherein the recess of the toilet fill valve is an annular recess located on a bowl fill outlet port side wall of the bowl fill outlet port, wherein the slot of the bowl fill valve is located on the bowl fill valve side wall, and wherein the extension of the toilet fill valve is a rib on the bowl fill outlet port side wall.

4. The toilet system of claim 1, wherein the bowl fill outlet port extends radially from a longitudinal axis of the body of the toilet fill valve.

5. The toilet system of claim 4, wherein the toilet fill valve further comprises an actuation arm that extends radially from the longitudinal axis of the body of the toilet fill valve, and wherein the actuation arm is angularly offset relative to the bowl fill outlet port.

6. The toilet system of claim 1, wherein the toilet fill valve further comprises a float configured to move along at least a portion of the body of the toilet fill valve.

7. The toilet system of claim 6, wherein the at least a portion of the body of the toilet fill valve extends through the float.

8. A bowl fill valve, comprising:

a bowl fill valve inlet port configured to mate directly to a bowl fill outlet port of a body of a toilet fill valve;

US 10,934,698 B1

11

a bowl fill valve outlet port configured to attach directly to a tube that provides water from the bowl fill valve outlet port to an overflow tube;

a protrusion configured to insert into a recess of the toilet fill valve and retain the bowl fill valve to the toilet fill valve, the protrusion being configured to snap fit into the recess;

a slot configured to receive an extension of the toilet fill valve and prevent rotation of the bowl fill valve relative to the toilet fill valve; and

a water flow adjustment handle being configured to adjust water flow from the bowl fill valve inlet port to the bowl fill valve outlet port.

9. The bowl fill valve of claim 8, wherein the bowl fill valve inlet port comprises a female receptacle for a male end of the bowl fill outlet port.

10. A method, comprising:

coupling a water inlet of a toilet fill valve to a water source;

attaching a bowl fill valve directly to a body of the toilet fill valve by at least:

 mating a bowl fill valve inlet port of the bowl fill valve directly to a bowl fill outlet port that extends from the body of the toilet fill valve;

 snap fitting a protrusion of the bowl fill valve into a recess of the toilet fill valve; and

12

inserting an extension of the toilet fill valve into a slot of the bowl fill valve, wherein the slot is configured to prevent rotation of the bowl fill valve relative to the toilet fill valve; and

attaching a tube directly to a bowl fill valve outlet port of the bowl fill valve.

11. The method of claim 10, further comprising adjusting a flow of water out of the bowl fill valve.

12. A bowl fill valve, comprising:

a bowl fill valve inlet port configured to mate directly to a bowl fill outlet port of a body of a toilet fill valve;

a bowl fill valve outlet port configured to attach directly to a tube that provides water from the bowl fill valve outlet port to an overflow tube;

a protrusion on the bowl fill valve configured to snap fit into a recess of the toilet fill valve and retain the bowl fill valve to the toilet fill valve;

a slot configured to receive an extension of the toilet fill valve and prevent rotation of the bowl fill valve relative to the toilet fill valve; and

means for adjusting water flow out of the bowl fill valve outlet port.

13. The bowl fill valve of claim 12, wherein the means for adjusting water flow out of the bowl fill valve outlet port comprises an adjustment handle.

14. The toilet system of claim 1, wherein the bowl fill valve inlet port is configured to be inserted within a portion of the bowl fill outlet port.

* * * * *

1
2
3
4
5
6
7
8
9
10
11
12
13
14
15
16
17
18
19
20
21
22
23
24
25
26
27
28

1
2
3
4
5
6
7
8
9
10
11
12
13
14
15
16
17
18
19
20
21
22
23
24
25
26
27
28

EXHIBIT D

1
2
3
4
5
6
7
8
9
10
11
12
13
14
15
16
17
18
19
20
21
22
23
24
25
26
27
28

EXHIBIT E