

**IN THE UNITED STATES DISTRICT COURT
FOR THE SOUTHERN DISTRICT OF FLORIDA
MIAMI DIVISION**

CASE NO. 1:23-CV-22679

SPIN SCREEN, INC.,

Plaintiff,

v.

IGNIS PIXEL LLC,

Defendant.

ORIGINAL COMPLAINT FOR PATENT INFRINGEMENT

Plaintiff, Spin Screen, Inc. (hereinafter, “Spin Screen” or “Plaintiff”), by and through its undersigned counsel, hereby respectfully files this Original Complaint for Patent Infringement against Defendant, Ignis Pixel, LLC (hereinafter, “Ignis” or “Defendant”), for infringement of U.S. Patent Nos. 8,284,214 (the “’214 Patent”) and 8,411,108 (the “’108 Patent”) (collectively, the “Patents-in-Suit”) as follows:

PARTIES

1. Plaintiff Spin Screen, Inc. is a corporation incorporated and existing under the laws of the State of Florida.
2. Upon information and belief, Defendant Ignis Pixel, LLC is a limited liability company organized and existing under the laws of the State of Florida, with a place of business at 2999 NorthEast 191st Street, Suite 907, Aventura, Miami-Dade County, Florida 33180, and can be served through its registered agent, Fincom Group USA Inc, 2999 NorthEast 191st Street, Suite 907, Aventura, Miami-Dade County, Florida 33180, or wherever the authorized employees, officers, directors, and/or managers of the foregoing may be found.

NATURE OF THE ACTION

3. This is a civil action for patent infringement to stop Defendant's infringement of the '214 Patent (attached hereto as **Exhibit 1**) and the '108 Patent (attached hereto as **Exhibit 2**).

4. Spin Screen alleges that Ignis has directly and/or indirectly infringed and/or continues to infringe the Patents-in-Suit by, *inter alia*, making, using (including in connection with internal uses and/or demonstrations), offering for sale, selling, importing, and/or inducing and/or contributing to such actions, including in connection with providing the infringing products and instructions/specifications for their use, including as detailed herein.

5. Ignis has had actual and/or constructive notice of the infringements alleged herein, including as detailed herein.

6. Spin Screen seeks damages and other relief for Ignis's infringement of the Patents-in-Suit, including as detailed herein.

JURISDICTION AND VENUE

7. This action arises under the Patent Laws of the United States, 35 U.S.C. § 1, *et seq.*, including 35 U.S.C. §§ 271, 281, 283, 284, and 285. This Court has subject matter jurisdiction over this case for patent infringement, including under 28 U.S.C. §§ 1331 and 1338(a).

8. This Court has personal jurisdiction over Defendant, including because Defendant is a Florida limited liability company; Defendant has minimum contacts within the State of Florida; Defendant has purposefully availed itself of the privileges of conducting business in the State of Florida; Defendant regularly conducts business within the State of Florida; and Plaintiff's cause of action arises directly from Defendant's business contacts and other activities in the State of Florida, including at least by virtue of Defendant's infringing methods, systems, devices, apparatuses, products, and/or services, which have been, and are currently, at least practiced, made, used, offered for sale, sold, and/or imported in the State of Florida. More specifically, Defendant

directly and/or through intermediaries, at least makes, distributes, imports, offers for sale, sells, advertises, and/or uses, the accused products and/or services identified herein, comprising the claimed systems and/or devices of the Patents-in-Suit in the State of Florida. Defendant is subject to this Court's specific and general personal jurisdiction, including pursuant to Constitutional Due Process and the Florida Long Arm Statute. Defendant is subject to this Court's general personal jurisdiction due at least to Defendant's continuous and systematic business contacts in Florida, including related to operations conducted in Florida and the infringements alleged herein. Further, on information and belief, Defendant is subject to this Court's specific personal jurisdiction, including because Defendant has committed patent infringement, and/or induced and/or contributed to the commission of patent infringement by others, in the State of Florida, including as detailed herein. Further, on information and belief, Defendant regularly conducts and/or solicits business, engages in other persistent courses of conduct, and/or derives substantial revenue from goods and/or services provided to persons and/or entities in Florida, including because Defendant solicits customers in the State of Florida, Defendant has paying customers who are residents of the State of Florida and who purchase and/or use Defendant's infringing products and/or services in the State of Florida and throughout the U.S., and Defendant has an interactive website and/or applications that are accessible from the State of Florida and throughout the U.S., and/or Defendant has placed, and continues to place, its infringing products and/or services into the stream of commerce via an established distribution channel with the knowledge and/or understanding that such products are being, and will continue to be, used, offered for sale, sold, and/or purchased in this Judicial District and the State of Florida.

9. Venue is proper in this District, including pursuant to 28 U.S.C. §§ 1391 and 1400(b), including because Defendant resides in the State of Florida at least by virtue of the fact that it is organized under the laws of the State of Florida; and Defendant has a principal place of

business in this District and at least some of the alleged infringement of the Patents-in-Suit occurs in this District.

SPIN SCREEN AND THE PATENTS-IN-SUIT

A. Spin Screen, Inc.

10. Plaintiff hereby refers to, and incorporates by reference, the allegations in the above paragraphs as if set forth fully herein.

11. Spin Screen, Inc. was founded in Florida in 2016 by Mark Gilbert, the primary inventor of the Patents-in-Suit, and an eighteen-year teacher of special education students with various disabilities whose teaching utilizes STEM-based learning programs which have brought continual success to these students which often come from marginalized communities. This background provided a backdrop upon which Mark devised the inventions of modern persistence of vision (“POV”) rotating light-emitting diode (“LED”) technology, including the inventions of the Patents-in-Suit, as a way to assist the visually impaired, to enhance visibility of emergency vehicles, and to introduce a new kind of visual display for artistic expression. Including as disclosed and claimed in the inventions of the Patents-in-Suit, these displays were devised to, *inter alia*, have a transparent background and be scalable, portable, linkable to multiple rotors, and be capable of both two dimension (“2-D”) and three dimension (“3-D”) pictures and videos. Small scale versions of these inventions have been used as a visual learning and focal instrument for students with severe autism and other cognitive and visual impairments.

12. Spin Screen initially operated under the brand name Lightning Wheelz, LLC, where, under Mark’s leadership, it developed rotating LED displays that utilize the POV effect as an enhancement for radio-controlled cars, helicopters, bicycle wheels, novelty items, and STEM toys. Spin Screen created early prototypes of a radio-controlled car and radio controlled helicopter, which were enough to attract small initial investments. Long-term testing on bicycle wheel lighting

products identified various product attributes that enhance the physical durability and visual display qualities thereof, for example, conformal epoxy coating over surface mount LEDs and semiconductors enhances resistance to vibration, water, and particle intrusion, thus enhancing the durability of the products to operate outdoors.

13. In order to obtain more funding to fully protect its inventions, during the period between 2004 and 2016, Spin Screen reached out to multiple companies and met with many CEOs of these companies, but found very little interest in, or support for, its inventions. Various innovation incubator programs also politely declined Spin Screen's requests. However, the few initial investments permitted Spin Screen to obtain patent protection for these inventions, including the Patents-in-Suit, and for ongoing improvements to, and variations of, the inventions and technologies. Broadly, the inventions disclosed and claimed in the Patents-in-Suit comprise, *inter alia*, a rotational display system for displaying both cylindrical and planar type displays in a single apparatus and/or providing a rotational display system which shows pre-defined and/or user-selected images, text, and/or video on a rotating display device (such as a vehicle wheel, rotating toy, helicopter blade, etc.), including via, *inter alia*, integrating multiple unique lighting technologies (including, *e.g.*, a rotatable assembly comprising at least one lighting assembly), computer systems, controller systems, switching systems, mounting and support systems, information delivery systems, and power supply systems (including, *e.g.*, power supply control mechanism) to display information on a rotating plane of the rotating display device, including via mapping the image to corresponding mathematical coordinates and toggling illuminating elements to create a POV image. *Id.* at Abstract; 1:36-60; 2:15-28; 2:47-3:7; 3:44-67; 4:18-6:15; 6:25-7:36; Claims of the Patents-in-Suit; *see also* Claims of U.S. Patent No. 7,271,813 (the "'813 Patent"; attached hereto as **Exhibit 3**), U.S. Patent No. 9,190,028 (the "'028 Patent"; attached hereto as **Exhibit 4**), & U.S. Patent No. 10,636,389 (the "'389 Patent"; attached hereto as **Exhibit 5**).

14. As part of its efforts to enforce its intellectual property rights, including via litigation, Spin Screen successfully entered into licenses with two infringing companies. In addition to two formal license deals, around 2016, Spin Screen began distributing and selling, under the Lightning Wheelz brand, its own products comprising bike wheel video lights which, at least in part, embodied the inventions of the Patents-in-Suit. Alas, the manufacturer Spin Screen had contracted began selling Spin Screen's patent-protected products worldwide without authorization through channels other than Spin Screen's Lightning Wheelz brand and under various brand names, and continues to do so.

15. More recently, Spin Screen has witnessed, first hand, the unconventionality and importance of its inventions, and seen an ever increasing amount of major tech companies cite to Spin Screen's unconventional, innovative inventions, including the Patents-in-Suit, extensively in their own patent filings. Spin Screen has reached out to various companies, including Defendant, offering to collaborate with them on the patented technology to keep advancing and growing the market for the POV LED products. These offers have included sharing Spin Screen's research, providing hardware and software testing and support services on the products of these companies, and suggesting ways to partner with these companies to advance these technologies, such as offering printed circuit board ("PCB") design services, asking only for public recognition of, or minimal compensation for, Spin Screen's unconventional, innovative contributions to the field.

16. Spin Screen continues to research and develop this field and continues to evaluate LED POV products in multiple categories. The heart of Spin Screen, and its founder, Mark, remains the drive to innovate and improve the world, including, *inter alia*, improving the lives of the special needs students that Mark teaches and to promote further development of POV imagery systems and devices as creative medium for artistic expression and for those with visual impairments.

B. Overview Of The Patents-in-Suit And Their Family

1. The '813 Patent

a. Overview of the '813 Patent

17. Plaintiff hereby refers to, and incorporates by reference, the allegations in the above paragraphs as if set forth fully herein.

18. The '813 Patent is entitled "Rotational Display System," and issued as U.S. Patent No. 7,271,813 (the "'813 Patent") on September 18, 2007 from U.S. Patent Application No. 11/187,625, filed on July 21, 2005, and claims priority to U.S. Provisional Patent Application No. 60/589,651 filed on July 21, 2004.

b. Overview of the Prosecution of the '813 Patent

19. Plaintiff hereby refers to, and incorporates by reference, the allegations in the above paragraphs as if set forth fully herein.

20. During prosecution of the '813 Patent, on November 24, 2006, the patent examiner issued a Non-Final Rejection, rejecting then-pending claims 1-10 and 12-17 under 35 U.S.C. § 102(e) as rendered unpatentable due to being anticipated by conventional U.S. Patent No. 7,079,042 to Reim ("*Reim*") and rejecting then-pending claim 11 under 35 U.S.C. § 103(a) as rendered unpatentable due to being obvious in view of conventional *Reim* and conventional U.S. Patent Publication No. 2002/0,133,282 to Ryan et al. ("*Ryan*").

21. On February 27, 2007, the applicant filed a response amending the claims and argued that then-pending claims 1-10 and 12-17, as amended, were not rendered unpatentable as anticipated by the cited conventional *Reim* reference and that then-pending claim 11, as amended, was not rendered unpatentable as obvious in view of the cited combination of the conventional *Reim* and conventional *Ryan* references, nor would it be obvious to combine these references.

22. In regard to the rejection under 35 U.S.C. § 103(a), the applicant noted that neither

conventional *Reim*, nor conventional *Ryan*, alone, or in combination, neither teach nor suggest, nor render obvious, either “a device which includes a surface containing LEDs that extend outwardly from the tire or wheel that would allow the LEDs to be viewed from the front or rear of the vehicle”; “any type of virtual headlights, tail lights, turn signals, emergency lights or anything else that could be viewed from the front or rear of the vehicle to provide increased safety to a user of the device”; or “substantially perpendicular surface having a rotatable light assembly outward from the wheel.”

23. On May 21, 2007, the patent examiner issued a notice of allowance.

2. *The '214 Patent*

a. Overview of the '214 Patent

24. Plaintiff hereby refers to, and incorporates by reference, the allegations in the above paragraphs as if set forth fully herein.

25. The '214 Patent is entitled “Rotational Display System,” and issued as U.S. Patent No. 8,284,214 on October 9, 2012 from U.S. Patent Application No. 11/840,335, filed on August 17, 2007, is a continuation of U.S. Patent Application No. 11/187,625, filed on July 21, 2005, which issued as the '813 Patent, and claims priority to U.S. Provisional Patent Application No. 60/589,651 filed on July 21, 2004.

b. Overview of the Prosecution of the '214 Patent

26. Plaintiff hereby refers to, and incorporates by reference, the allegations in the above paragraphs as if set forth fully herein.

27. During prosecution of the '214 Patent, on May 8, 2009, the applicant filed a preliminary amendment, cancelling then-pending claims 1-17, and adding new claims 18-34.

28. On July 26, 2010, the patent examiner issued a Non-Final Rejection, rejecting then-pending claims 18-34 under 35 U.S.C. § 102(e) as rendered unpatentable due to being anticipated

by conventional U.S. Patent No. 7,477,208 to Matlock et al. (“*Matlock '208*”).

29. On November 22, 2010, the applicant filed a response amending the claims, cancelling then-pending claims 20 and 26, and argued that then-pending claims 1-19, 21-25, and 27-34, as amended, were not rendered unpatentable as anticipated by the cited conventional *Matlock '208* reference.

30. In regard to the rejection under 35 U.S.C. § 102(e), the applicant noted in its response to the patent examiner’s rejection that conventional *Matlock '208* did not teach or suggest “a rotational display device that orients the displayed image in alignment with a predetermined planer axis.”

31. On February 11, 2011, the examiner issued a Final Rejection, rejecting then-pending claims 18-19, 21-25, and 27-34 under 35 U.S.C. 103(a) as rendered unpatentable due to being obvious in view of in view of conventional *Matlock '208* and conventional U.S. Patent No. 6,492,963 to Hoch (“*Hoch*”).

32. On July 11, 2011, the applicant filed a request for continued examination (“RCE”). As part of the RCE filing, the applicant amended the claims and argued that then-pending claims 18-19, 21-25, and 27-34, as amended, were not rendered unpatentable as obvious in view of the cited combination of the conventional *Matlock '208* and conventional *Hoch* references, nor would it be obvious to combine these references.

33. In regard to the rejection under 35 U.S.C. § 103(a), the application noted that neither conventional *Matlock '208*, nor conventional *Hoch*, alone, or in combination, neither teach nor suggest, nor render obvious, either “a rotational display system capable of displaying graphics without bending the text and graphics around the axis of rotation”; or “a device that would allow the text to be displayed across a flat datum line.”

34. On November 1, 2011, the patent examiner issued a notice of allowance.

3. *The '108 Patent*

a. Overview of the '108 Patent

35. Plaintiff hereby refers to, and incorporates by reference, the allegations in the above paragraphs as if set forth fully herein.

36. The '108 Patent is entitled "Rotational Display System," and issued as U.S. Patent No. 8,411,108 on April 2, 2013 from U.S. Patent Application No. 12/646,422, filed on December 23, 2009, is a continuation-in-part of U.S. Patent Application No. 11/840,335, filed on August 17, 2007, which issued as the '214 Patent, and which is a continuation of U.S. Patent Application No. 11/187,625, filed on July 21, 2005, which issued as the '813 Patent, and claims priority to U.S. Provisional Patent Application No. 60/589,651 filed on July 21, 2004.

b. Overview of the Prosecution of the '108 Patent

37. Plaintiff hereby refers to, and incorporates by reference, the allegations in the above paragraphs as if set forth fully herein.

38. During prosecution of the '108 Patent, on November 12, 2012, the applicant filed a preliminary amendment, cancelling then-pending claims 1-54, and adding new claims 55-75.

39. On November 14, 2012, the applicant had a telephonic interview with the examiner, discussing then-pending claims 70 and "Examiner proposed an examiner's amendment" which was agreed to by the applicant.

40. On November 27, 2012, the patent examiner issued a notice of allowance.

4. *The '028 Patent*

a. Overview of the '028 Patent

41. Plaintiff hereby refers to, and incorporates by reference, the allegations in the above paragraphs as if set forth fully herein.

42. The '028 Patent is entitled "Rotational Display System," and issued as U.S. Patent No. 9,190,028 (the "'028 Patent") on November 17, 2015 from U.S. Patent Application No.

13/778,970, filed on February 27, 2013, is a continuation of U.S. Patent Application No. 12/646,422, filed on December 23, 2009, which issued as the '108 Patent, and which is a continuation-in-part of U.S. Patent Application No. 11/840,335, filed on August 17, 2007, which issued as the '214 Patent, and which is a continuation of U.S. Patent Application No. 11/187,625, filed on July 21, 2005, which issued as the '813 Patent, and claims priority to U.S. Provisional Patent Application No. 60/589,651 filed on July 21, 2004.

b. Overview of the Prosecution of the '028 Patent

43. Plaintiff hereby refers to, and incorporates by reference, the allegations in the above paragraphs as if set forth fully herein.

44. During the prosecution of the '028 Patent, on October 24, 2014, the examiner issued a Non-Final Rejection, requiring a restriction for then-pending claims 1-54 under 35 U.S.C. § 121, stating that then-pending claims 1-54 comprise independent and distinct species because they are patentably distinct species of systems, including the species of claims 1-19, the species of claims 20-37, and the species of claims 38-54.

45. On December 22, 2014, the applicant filed a response electing to continue prosecution of the species of claims 38-54, and withdrew then-pending claims 1-37.

46. On January 30, 2015, the examiner issued a Non-Final Rejection in response to the applicant's election, rejecting the then-pending claims of the elected species, claims 38-42 and 51-54, under 35 U.S.C. 103(a) as rendered unpatentable due to being obvious in view of conventional U.S. Patent Publication No. 2004/0,183,696 to Low ("*Low*") and conventional U.S. Patent Publication No. 2002/0,135,541 to Kowalewski ("*Kowalewski*"), and objected to the then-pending claims of the elected species, claims 43-50, as being dependent, as written, upon rejected base claims.

47. On June 30, 2015, the applicant filed a response amending the claims of the elected

species, and argued that the then-pending claims of the elected species, as amended, were not rendered unpatentable as obvious in view of the cited combination of the conventional *Low* and conventional *Kowalewski* references.

48. In regard to the rejection under 35 U.S.C. § 103(a), the applicant noted that neither conventional *Low*, nor conventional *Kowalewski*, alone, or in combination, neither teach nor suggest, nor render obvious, “the claimed communication device with illuminated display.”

49. On July 17, 2015, the patent examiner issued a notice of allowance.

5. *The '389 Patent*

a. Overview of the '389 Patent

50. Plaintiff hereby refers to, and incorporates by reference, the allegations in the above paragraphs as if set forth fully herein.

51. The '389 Patent is entitled “Rotational Display System,” and issued as U.S. Patent No. 10,636,389 (the “'389 Patent”) on April 28, 2020 from U.S. Patent No. 14/942,626, filed on November 16, 2015, is a division of U.S. Patent Application No. 13/778,970, filed on February 27, 2013, which issued as the '028, and which is a continuation of U.S. Patent Application No. 12/646,422, filed on December 23, 2009, which issued as the '108 Patent, and which is a continuation-in-part of U.S. Patent Application No. 11/840,335, filed on August 17, 2007, which issued as the '214 Patent, and which is a continuation of U.S. Patent Application No. 11/187,625, filed on July 21, 2005, which issued as the '813 Patent, and claims priority to U.S. Provisional Patent Application No. 60/589,651 filed on July 21, 2004.

b. Overview of the Prosecution of the '389 Patent

52. Plaintiff hereby refers to, and incorporates by reference, the allegations in the above paragraphs as if set forth fully herein.

53. During the prosecution of the '389 Patent, on May 12, 2016, the examiner issued a

Non-Final Rejection, allowing then-pending claims 20-37; rejecting then-pending claim 1 on the grounds of non-statutory double patenting over claim 16 of the related '108 Patent; and objected to then-pending claims 3-19 as being dependent, as written, upon rejected base claims.

54. On August 11, 2016, the applicant filed a response and argued the non-statutory double patenting rejection is overcome by the applicant's contemporaneous filing of a terminal disclaimer.

55. On June 12, 2017, the examiner issued a Final Rejection, maintaining the allowance of then-pending claims 20-37; rejection of then-pending claim 1 on the grounds of non-statutory double patenting over claim 16 of the related '108 Patent; and objection to then-pending claims 3-19 as being dependent, as written, upon rejected base claims.

56. On October 12, 2017, the applicant filed a response and argued the non-statutory double patenting rejection is overcome by the applicant's contemporaneous filing of a terminal disclaimer.

57. On December 28, 2017, the examiner issued a Non-Final Rejection, allowing then-pending claims 20-37; interpreting the term "power delivery means" under 35 U.S.C. § 112, ¶ 6, as a means-plus-function term using a generic placeholder "means" coupled with functional language "for providing power"; rejecting then-pending claims 1-8, 12-14, and 17 under 35 U.S.C. § 102(e) as rendered unpatentable due to being anticipated by conventional U.S. Patent Publication No. 2005/0,174,308 to Matlock et al. ("*Matlock '308*"); and objecting to then-pending claims 9-11, 15, 16, 18, and 19 as being dependent, as written, upon rejected base claims.

58. On April 27, 2018, the applicant filed a response amending the claims, and canceling then-pending claim 11, accepted the examiner's interpretation of the term "power delivery means" as a means-plus-function term under 35 U.S.C. § 112, ¶ 6, and argued that then-pending claims 1-8, 12-14, and 17, as amended, are not rendered unpatentable as anticipated by

the cited conventional *Matlock '308* reference.

59. On June 29, 2018, the examiner issued a Final Rejection, allowing then-pending claims 20-37; reiterating its interpretation of the term “power delivery means” under 35 U.S.C. § 112, ¶ 6, as a means-plus-function; rejecting then-pending claims 1-8, 12-14, and 17 under 35 U.S.C. § 103(a) as rendered unpatentable due to being obvious in view of conventional *Matlock '308* and conventional *Hoch*; and objecting to then-pending claims 9, 10, 15, 16, 18, and 19 as being dependent, as written, upon rejected base claims.

60. On December 21, 2018, the applicant filed a RCE. As part of the RCE filing, the applicant amended the claims and argued that then-pending claims 1-8, 12-14, and 17, as amended, were not rendered unpatentable as obvious in view of the cited combination of the conventional *Matlock '308* and conventional *Hoch* references, nor would it be obvious to combine these references.

61. In regard to the rejection under 35 U.S.C. § 103(a), the applicant noted in its response to the patent examiner’s rejection that neither conventional *Matlock '308*, nor conventional *Hoch*, alone, or in combination, neither teach nor suggest, nor render obvious, a device “allowing text to be displayed the same as a television in a linear”; “components of the 3-D display system of claim 20 including the display assembly to simultaneously rotate the illuminating assembly about at least two axes of rotation and the control system as claimed.”

62. On January 23, 2019, the examiner issued a Non-Final Rejection, allowing then-pending claims 9-10 and 20-37; reiterating its interpretation of the term “power delivery means” under 35 U.S.C. § 112, ¶ 6, as a means-plus-function; rejecting then-pending claims 1-8, 12-14, and 17 under 35 U.S.C. § 103(a) as rendered unpatentable due to being obvious in view of conventional *Matlock '308* and conventional *Hoch*; and objecting to then-pending claims 9, 10, 15, 16, 18, and 19 as being dependent, as written, upon rejected base claims.

63. On April 23, 2019, the applicant filed a response amending the claims, and argued that then-pending claims 1-8, 12-14, and 17, as amended, were not rendered unpatentable as obvious in view of the cited combination of the conventional *Matlock '308* and conventional *Hoch* references, nor would it be obvious to combine these references.

64. In regard to the rejection under 35 U.S.C. § 103(a), the applicant reiterated the applicant's arguments relating to the cited conventional *Matlock '308* and conventional *Hoch* references.

65. On May 15, 2019, the examiner issued a Final Rejection, allowing then-pending claims 9-10 and 20-37; reiterating its interpretation of the term "power delivery means" under 35 U.S.C. § 112, ¶ 6, as a means-plus-function; rejecting then-pending claims 1-8, 12-14, and 17 under 35 U.S.C. § 103(a) as rendered unpatentable due to being obvious in view of conventional *Matlock '308* and conventional *Hoch*; and objecting to then-pending claims 15, 16, 18, and 19 as being dependent, as written, upon rejected base claims.

66. On November 15, 2019, the applicant filed a response amending the claims, and argued that then-pending claims 1-8, 12-14, and 17, as amended, were not rendered unpatentable as obvious in view of the cited combination of the conventional *Matlock '308* and conventional *Hoch* references, nor would it be obvious to combine these references.

67. In regard to the rejection under 35 U.S.C. § 103(a), the applicant noted in its response to the patent examiner's rejection that neither conventional *Matlock '308*, nor conventional *Hoch*, alone, or in combination, neither teach nor suggest, nor render obvious, a device that can "display text or graphics across the display on an unbent plane extending across the display."

68. On January 8, 2020, the patent examiner issued a notice of allowance.

6. Overview of the Unconventional Inventions of the Patents-in-Suit and the Conventional Technology at the Time

69. Plaintiff hereby refers to, and incorporates by reference, the allegations in the above paragraphs as if set forth fully herein.

70. In the early 2000's, at the time of the disclosures reflected in the Patents-in-Suit (the "Patented Inventions"), although rotating POV devices existed, they were limited to simple devices with little or no programming or customization ability. *See, e.g.*, '108/1:16-6:50.¹ By way of example, a very popular device of the early 2000's was a programmable battery powered handheld fan that contained a few pre-programmed messages like "happy birthday" in monochrome red. *See, e.g., id.* at 2:61-3:48. These devices, however, were very limited, including because limits to, *inter alia*, programming and storage at the time limited the devices to simple, low-quality text and pixel images stored on the device, circularly distorted display of said text and images, with no ability to import or export digital media to be displayed. *See, e.g., id.* at 3:46-4:16 & 4:57-67.

71. The '813 Patent (the "parent" of each of the Patents-in-Suit) outlines the history of POV devices dating back to pre-World War II ("WW2"), further referenced in the four children patents that followed. *See, e.g., id.* at 1:16-6:50. More specifically, numerous systems for producing visual images and displaying visual information (such as pictures, text, and/or full motion video sequences) were developed over a century ago, including technology utilizing rotating assemblies with intermittently illuminated elements to produce text or basic shapes. *Id.* at 1:29-34. The rotation, combined with these rapidly changing elements, produces a series of flashing frames that blend to form a recognizable image, or series of images, resulting in an effect

¹ The specification for each of the Patents-in-Suit are similar, and comprise the entirety of the specification of the parent '813 Patent. As the specification of the '108 Patent is the deepest, any references to the specification herein shall be to the specification of the '108 Patent and shall apply equally to each of the Patents-in-Suit.

broadly referred to as Persistence of Vision, “POV,” or, more specifically, “scanning” on older systems developed before WW2. *Id.* at 1:34-38. In modern devices utilizing POV technology, electronic information about a displayed image is used to synchronize the illumination of individual illuminating elements at specific positions during rotation. *Id.* at 1:38-42.

72. At the time of the disclosures of the Patents-in-Suit, there were generally two types of conventional POV displays: 1) cylindrical POV displays, which rotate an LED display in a manner that creates images in a cylindrical form – as if the images were on the side of a soda can; and 2) planar POV displays, which rotate an LED display so that they appear in a flat disk-shaped area. *Id.* at 1:43-48. Within a planar display, small bright illuminating elements are typically arranged along an elongated flat member, with an axle positioned about the mid-point, similar to an airplane propeller, and a motor is provided to rotate the member at a relatively high speed, which creates the blur perceived by the eye and makes the rotating member appear to be a flat “virtual” circle forming a visual image when color, brightness, and timing of the illuminating sections on the member are properly synchronized. *Id.* at 1:48-58.

73. Including as set forth in the disclosures of the Patents-in-Suit, one of the earliest examples of image producing systems that utilized a rotating member, a series of illuminating devices, and a system of synchronizing to display an image, was a system of receiving and reproducing images developed and patented in 1884 which utilized a selenium photocell and a (rotating) scanning disk. *Id.* at 1:59-65. In order to capture an image, this early system employed the scanning disk with a single row of holes arranged such that they spiraled inward toward the center of the circle while the disk revolved in front of a light sensitive plate on which a lens formed an image. *Id.* at 1:65-2:2. Each hole passed across, or “scanned” a ring-shaped portion of the image and traced contiguous concentric circles so that, in one revolution of the disk, the entire image was scanned, converting a visible image to a series of electrical signals. *Id.* at 2:2-6. A similar rotating

disk system was used to reproduce the image that had been scanned, including by rapidly switching a series of lights aligned with the holes in the rotating disk, so synchronized illumination passed through the holes, tracing an image with many concentric circles of light. *Id.* at 2:6-11. Similar systems followed which successfully demonstrated television (“TV”) systems using scanning disks in 1926, with such systems producing sixty to one hundred scanned lines to provide recognizable black and white images that were considered “high-quality” by 1926 standards. *Id.* at 2:12-18.

74. Around 1928, and by the 1930’s, research and development of video display systems employing rotating mechanical scanning came to an end when further advancements provided for systems which scanned an electron beam back and forth across the inside of a glass cathode ray tube, striking a phosphorescent surface plane, causing images to appear on a glass picture tube. *Id.* at 2:19-27 & 2:37-48. These electronic scanning picture tube designs became the foundations for the cathode ray tube that was further perfected and marketed in the first home TV receivers. *Id.* at 2:27-30. Subsequent significant picture tube improvements increased the reliability, quality, and display size of picture tubes during the 1930’s, with this same electron scanning technology evolving into the high-quality glass picture tubes that are still found in present day color (picture tube type) TVs and computer monitors (until the early 2000’s when flat format rectangular screens became more popular). *Id.* at 2:31-36. These early picture tubes were essentially sealed, low maintenance systems with no mechanical components, while the illumination systems, propulsion means, synchronization circuits, and power requirements of prior rotary mechanical visual display systems made them heavy, bulky, inefficient, unreliable, and of marginal value, including due to low video quality when compared to prior cathode ray tube visual displays – particularly during this time period before WW2. *Id.* at 2:40-47.

75. Consequently, since the pre-WW2 popularity of the cathode ray tube, its ability to

display data based on analog signal driven vertical and horizontal movement of the electron beam by a modulated magnetic field helped drive it to become a de-facto mathematical standard worldwide for the method of displaying images on an electronic screen. *See id.* at 2:19-27 & 2:37-48. As the rectangular screen evolved as a popular worldwide standard (evolving in much later decades from analog to digital signals), the early pre-WW2 work on rotating POV displays as a means of rotational image display had largely been forgotten and lost to time as an obsolete electronics format. *See id.* at 12:35-52. From the analog radio signals that produced the vertical and horizontal movement of the electron beam across, the early cathode ray tube evolved into the rectangle as the accepted shape of nearly all screens. *See id.* at 2:19-27, 2:37-48, & 12:35-52. Even after the advent of computerization, and the ability to provide a digital signal to illuminate a 1980's projection TV, or a 1990's liquid crystal display ("LCD") screen or Plasma Cell Array TV, the shape was still a rectangle. It was only in the early 2000's that a spinning, rotating flickering collection of lights would be used again for display purposes with the implementation of a few new products, and with the new technology described herein, including those inventions disclosed in the Patents-in-Suit, including a rotational display system for displaying both cylindrical and planar type displays in a single apparatus and/or providing a rotational display system which shows pre-defined and/or user-selected images, text, and/or video on a rotating display device (such as a vehicle wheel, rotating toy, helicopter blade, etc.), including via, *inter alia*, integrating multiple unique lighting technologies (including, *e.g.*, a rotatable assembly comprising at least one lighting assembly), computer systems, controller systems, switching systems, mounting and support systems, information delivery systems, and power supply systems (including, *e.g.*, power supply control mechanism) to display information on a rotating plane of the rotating display device, including via mapping the image to corresponding mathematical coordinates and toggling illuminating elements to create a POV image. *Id.* at Abstract; 1:36-60; 2:15-28; 2:47-3:67; 4:18-

6:15; 6:25-7:36; Claims of the Patents-in-Suit; *see also* Claims of the '813 Patent, '028 Patent, & '389 Patent. Several recent products employ new uses and variations thereof based on illuminated rotational scanning display systems which define a group of conventional prior art that are related to the new, useful, and unconventional inventions disclosed in the Patents-in-Suit. *Id.* at 2:52-56.

76. One such conventional rotating LED device receives data by infrared transmission and then displays such data by synchronizing the illumination display of a row of rotating LEDs. *Id.* at 2:57-61. The device is specifically embodied as both a functional and ornamental device that is used to display incoming telephone caller numbers as a caller ID apparatus, and further displays other alpha-numeric information such as the time, date and a few pre-programmed seasonal greetings that are stored in the unit's internal memory. *Id.* at 2:61-67. The rotating member containing the LED array must synchronize the display of information as rapidly as it rotates, so the device transmits infrared signals to a rotating illuminating member, from an infrared transmitter located in the stationary base unit which effectively separates the actual rotating member and LED array from its support circuits that need not rotate in order to produce a visual image. *Id.* at 2:67-3:4. The conventional infrared system described provides a wireless path by which information to be displayed is beamed directly to a small infrared receiver that is part of the rotating display system, which minimizes the amount of parts that must rotate, thus minimizing rotational mass, minimizing the weight of moving parts, but, because the device derives both a positional reference point and data concurrently as a predetermined point on the rotating arm passes the infrared sender, the amount of data that can be transferred is very limited. *Id.* at 3:7-16. It is also notable that devices at the time of the Patents-in-Suit, such as this, were not capable of producing an image that was clear or level, including because no processes were known to indicate how to automatically and rapidly convert (the data that comprises) a rectangular image to an image directly displayable upon a rotating lighted array. This is why POV devices of the late 1990's to

early 2000's bent their images in a circular manner, thus preventing the display of high-quality images such as those on TV or movie screens during this time period. *Id.* at 3:4-16.

77. Thus, although conventional devices at the time of the disclosures of the Patents-in-Suit comprised rotating POV products, these produced poor quality images which were limited to displaying only low resolution alpha-numeric data, caller ID information, clock settings, a series of pre-determined greetings through a hardware button-switch style interface, and/or simple pictures that were only a few pixels across. *Id.* at 3:17-32. However, these conventional device designs did not disclose hardware, systems, methods, or other provisions capable of providing motion picture sequences that are user-selected, or supplied through an external source such as a digital media system, DVD, hard drive, or other data storage device. *Id.* at 3:19-24. Moreover, the Patents-in-Suit disclose that early, conventional POV devices were monochromatic, had support circuitry that limits data and image display throughput to the monochromatic color output of the included display devices, and were incapable of displaying a true color image that was both level and stable. *See id.* at 3:17-36. Even if the LED arrays disclosed in these conventional devices were made multi-colored for ornamental purposes, the internal processing systems at the time were only designed to synchronize the on/off LED array switching to display alpha-numeric data and a few low resolution symbols. *Id.* at 3:27-32. Furthermore, no processes had been disclosed indicating how to automatically convert a rectangular image, or series of rectangular image frames, based upon a series of digital data intended for a rectangular screen, to an image that could be directly displayed by a group of spinning, rapidly flickering LEDs or lights. *Id.* Thus, the hardware and software of these conventional devices could not support streaming color video to display life-like color images or color full motion video, including because the systems were not wired and programmed to support true color synchronized switching or related data throughput. *Id.* at 3:32-36.

78. Another conventional spinning illuminated novelty device with synchronized light sources existed as essentially a small, portable, battery-operated amusement device that spins an array of lights. *Id.* at 3:37-41. In these devices, a small control circuit is located on the rotating member, proximal to the light array and contains predetermined embedded ornamental patterns that cause the light array to illuminate in a predetermined pattern, synchronous to their speed, resulting in an ornamental lighted display of shapes, colors, images, and/or text to appear, depending on the predetermined pattern data integral to the control circuit. *Id.* at 3:41-48. Such conventional devices typically use a rotating contact system, such as a slip-ring style contact, to directly energize a control circuit and lights on the moving blades, which allows the stationary battery pack to directly connect its power wires to the illumination system and illumination control circuit on the moving rotor. *Id.* at 3:48-53. As these systems were primarily designed as affordable children's toy, they were likewise generally incapable of the advanced requirements necessary to display true color synchronized switching. *Id.* at 3:54-57.

79. Further, the control circuit of these conventional devices was primarily a low-cost pre-programmed device that displayed a few visual patterns of varying colors, with user-selectability of pre-programmed patterns not being present, to keep production cost low, and minimize user interface parts – *i.e.*, the illumination patterns are generated by the digital controller in a predetermined manner. *Id.* at 3:57-63. Thus, unlike the new, useful, and unconventional inventions disclosed in the Patents-in-Suit, the users of these conventional devices could not select from multiple of predetermined groups of images or messages to be displayed, nor could the user program and/or add any images. *Id.* at 3:63-65. Thus, the preferred embodiment shows only a simple on/off hardwired switch as the only human interface device present. *Id.* at 3:65-67.

80. Other similar conventional devices include virtual color generating windmills, decorative spinners, and ornamental devices powered by solar or wind energy, rather than a

battery, to power the integrated illumination systems to add to the visual interest of the windmill or similar outdoor ornament. *Id.* at 4:1-8. During operation of these conventional devices, the windmill turns, sets of small LEDs scan rotational patterns of light creating an ornamental effect. *Id.* at 4:8-10. While this system employs rotational scanning, images displayed contain little or no parameters for user selectability, and are incapable of displaying life-like color images or color full motion video. *Id.* at 4:10-14.

81. Another conventional amusement device existing at the time of the inventions of the Patents-in-Suit which employed rotational image display is the “I-Top,” a small, portable pocket-sized, battery-operated spinning top with an integrated array of eight LEDs. *Id.* at 4:14-19. Using a button switch on the I-Top, a user can select from a series of pre-programmed games that are integral to the unit's controller, and then spins the I-Top so that the toy displays scores, messages, and animations through its array of LEDs that form a virtual screen while spinning. *Id.* at 4:19-24. In these conventional devices, a temporary, marginally stable display image is accomplished by, *inter alia*, using a built-in magnetic compass that always knows the instantaneous position of the top, and synchronizes the illumination display output flashes for each LED accordingly based on rotational position. *Id.* at 4:24-28. Due to the use of this compass-based position sensor disposed inside the I-Top, the beginning point of any chain of words on the I-Top is always pointing to Earth’s magnetic North, which is used as a reference for the LED synchronization, and to calibrate in which direction or position the output text should appear. *Id.* at 4:29-34. However, the limitations of the magnetic sensor within the I-Top (and similar devices) allowed for a high degree of screen flicker, and, although text appeared somewhat upright with reference to Earth’s magnetic field, it was common for these devices to wobble the image plus or minus 15 degrees right or left during normal operation. Image flicker and roll would increase to the point where the screen display would roll left or right, and fully upside down, in response to

any nearby magnetic influence. As the I-Top internal magnetic position sensor was intended to detect the Earth's field strength of approximately 0.25 to 0.65 Gauss, its actual sensitivity was a far wider range than this desired threshold. Therefore, any nearby electrical device, or nearby metallic object consisting of a ferromagnet, or even paramagnetic, composition, caused the displayed image to flicker, spin, and/or roll. As a result, in these situations, these devices were simply unable to maintain a stable and level image for more than a few seconds.

82. While these conventional compass-based positional synchronization systems work very well for low resolution devices which rotate solely in a horizontal plane, a traditional compass-based system will not provide adequate positional synchronization for devices which rotate in vertical, or near-vertical, planes, including because the internal compass can become confused if the azimuth or angular orientation of its intended operational plane is shifted to a degree at which it cannot properly track the Earth's magnetic field. *Id.* at 4:35-42. Notably, at the time of the I-Top, popular internal magnetic sensors were typically a single-axis hardware device – far different than the tiny and precise variety multi-axis highly stabilized microchip devices used in modern devices. In addition, proximity to various metals, magnetic fields, and radio frequency interference from cellular phones, vehicle electronics, and other high-frequency sources also interferes with compass function via direct magnetic field distortion or by subsequent inductive jamming of sensitive compass support circuitry, which, in turn, confuses positional synchronization, and, thus, corrupts and distorts the images output on the illuminated array, making the device unsuitable for use as disclosed in the Patents-in-Suit, including in conjunction with vehicles, including vehicle wheels, and/or other devices having higher speed rotation. *Id.* at 4:42-51.

83. Other conventional devices in the early 2000's which utilized scanning technology include devices commonly known online as "propeller clocks" – a POV display that arose as a

niche hobby after what is presumed to be the first POV LED display (that displayed the digital time on a rotating cylindrical swept LED bar) was created. *Id.* at 4:52-58. These conventional clock devices comprised a rotating LED array that spun much like an airplane propeller, thus initiating the term “propeller clock” that became a generic name for many similar rotationally scanned devices during the early 2000’s and referred to early cylindrical and early planar type rotating POV displays. *Id.* at 4:58-61. More specifically, most of these conventional devices take the form of a rotating array of LEDs, a motor system to power the rotation, a system of delivering power to the motor and rotating LEDs, and a system to synchronously energize the LEDs, thus allowing the rotating array to visually display one or more desirable patterns. *Id.* at 4:61-67. Most of these propeller clocks were hand made and were generally shared in various obscure online science communities of the late 90s and early 2000’s. They were popular among hobbyists who would display their handmade units – often with hand-wired breadboard-style circuit boards glued onto rotating sections of wood dowels or plastic affixed to a motor. These early rotating POV systems required extensive, time-consuming computer programming and had limited display capacity and a high degree of distortion.

84. Additionally, early and conventional devices often displayed only individual digits upright with respect to the position of an external sensor, magnet, or switch, but with a high degree of circular distortion – for example, a 2002 project referred to as Fuzzcraft.

85. Including as noted herein, at that time, the upright display of letters and numbers on a planar rotating LED screen was only possible via manually programming the computers controlling the light control functions only because text and digits are very simple to program as a few individual points of light; for example, a series of four lighted dots arranged vertically can be easily understood as the digit “1,” and similar lighted dot groups could form simple letters and numbers. In essence, POV systems from 2004 and earlier (such as propeller clocks) had so few

lighted dots or pixels, that the task of making a letter and/or number appear upright required manual, time-consuming programming – for example, a 2015 university POV system which was designed using antiquated methods developed for POV projects dating back to 2002. Another exemplary POV display device released in March of 2009 by Northwestern Mechatronics illustrates the complexity of manually creating programs to drive a rotating POV display, wherein the Northwestern University Center for Robotics and Biosystems developed “POV-PC,” which was among the first working software programs to allow several skilled programmers enrolled in a college level computer engineering curriculum to reduce their weeks of POV software coding/programming down to days or hours of coding just to display a few simple messages on a rotating screen.

86. As early rudimentary software was released in 2009, programming a rotating POV system manually prior to 2004 was far more complex, time-consuming, and limited in capability, including due to hardware limitations, lack of available specialized software, and need for POV enthusiasts to create and build custom hardware and software to move minimal amounts of data from a PC to an early POV device. These were formidable limitations to the quality and usefulness of rotating POV displays in 2004. At that time, there was no automatic process, algorithms, software programs, or interface systems that would allow a complex color image to display clearly on an early POV display. Thus, any early display POV displays that were not completely distorted along a circular axis (for example, causing the “6” on a round analog clock face to appear upside down as a “9”) was limited only to the upright, low resolution, high-flicker, and jittery display of dot letters and dot numbers and small low-resolution images made of individual pixels.

87. In general, these conventional devices addressed and solved some of the technical challenges that surround rotational displays, such as technical challenges relating to construction of rotating displays, selection of appropriate high brightness LEDs for monochromatic displays,

proper balance and vibration control of rotating displays, methods of delivering reliable electrical power to the rotating portion of displays, methods and hardware for position sensing on the display, data delivery for displaying images on rotating arrays, and programmable integrated circuit programming and related costs, but they fail to address the many issues noted herein, and as described in the Patented Inventions. *Id.* at 5:1-12. Thus, in addition to the disclosures of the Patents-in-Suit that none of the many conventional devices and technologies existing at that time were capable of providing true color or streaming video to a screen comprised of rotating LEDs, the way that these devices displayed text could further make it difficult to read or view the displayed text or images, including due to a non-presence of a real horizontal reference. *See id.* at 5:13-36. Indeed, early POV devices distorted the image displayed, including due to interference, displaying the images directly from their plane of rotation, and/or by wrapping the image around the rotation axle, giving the images a twisted appearance that often flickered and jumped response to minor rotation speed changes. *See id.* at 5:60-64 & 12:35-40. The root cause of this distortion, thus the device's inability to display clear, level, stable images equal to a TV or movie screen at that time was because no processes had yet been disclosed indicating how to automatically and rapidly convert a rectangular image data (or series of rectangular image frames comprising a motion picture), from digital data intended for a rectangular screen to an image directly displayable across the visual plane formed by a rotating array of LEDs. *Id.* at 5:26-54.

88. Markedly, on displays available at the time of the Patents-in-Suit displayed words wrapped around the POV rotating display device's axle as if each letter in the word were being spiraled in a blender. *Id.* at 12:35-40. In essence, only part of the circle swept by the fan blade could be used for optical display and that portion was severely distorted by the rotation of the LEDs, thus incapable of displaying any high-quality image. Existing POV display products at the time were not capable of displaying an image level to the horizon as one would expect to see in a

photograph, movie, or computer monitor, or upon a typical TV screen. *Id.* at 12:35-40.

89. That is, these conventional devices twist the (normally horizontal) ground plane of the image or text around the axis of rotation causing, text, numbers, and/or animations to be displayed and scrolled in a circular pattern along an artificial bottom line that is actually defined by a circular path from rotation of the POV, causing the user to read text that bends around the circle of rotation, as opposed to across the circle of rotation. *Id.* at 5:17-23. This common design feature is a result of these conventional devices not defining a real horizontal reference within the actual programming code, data processes and internal feedback loops that process and ultimately synchronize output data to illuminate sections of a rotational display, including because failing to define a real visual ground plane reference for display purposes, and further not correlating a visual display ground plane with the horizon or actual ground, eliminates related programming complexities and internal algorithms. *Id.* at 5:23-31. The non-presence of this feature in the prior art allows for the use of a simple, low cost microprocessor controllers with limited complexity. *Id.* at 5:31-33. However, including as noted herein, and in the disclosures of the Patents-in-Suit, conventional devices could be difficult to read and render the possibility of full motion video displays across the entire virtual disk-shaped display near-impossible, including due to lack of any process that disclosed how a combination of hardware and/or software could automatically and/or instantaneously convert a rectangular image, or series of rectangular image frames intended for a rectangular screen, to an image directly displayable by a rotating array of LEDs in a sufficiently short time span to make the type video display possible in the same manner as disclosed in the Patents-in-Suit. *Id.* at 5:34-36.

90. Another problem disclosed in the specification of the Patents-in-Suit is that, in prior, conventional planar display devices, there was a part in the middle that blocked the light, which made it difficult to create images that went right to the middle. *Id.* at 5:37-48. More

specifically, the geometry of these conventional devices comprise some object or component mounted at the center of the circle of rotation that blocks the presence of illuminating elements so that the total display area that could potentially produce an illuminated image is hindered by a “hole” or circular blank spot at the middle of the circle. *Id.* at 5:37-42. This geometric limitation, which also applies to, and is later addressed by, the inventions disclosed in the Patents-in-Suit, provides another reason why text and images are displayed in a manner to twist around the center of rotation, and further limited the commercial value and applications of rotating POV displays, including due to the appearance of a hole in the middle of the screen. *Id.* at 5:42-46. This virtual hole was yet another reason that hobbyists and others familiar with POV believed that circular displays were unlikely to evolve to handle flat, level, color, television quality images. *Id.* Simply put, if the center of the spinning array of LEDs does not have illumination hardware, any image programmed to intersect the center of the circle would not display properly. *Id.* at 5:46-48.

91. These same limitations similarly affected the quality of early scanning image systems, and the aforementioned display systems of the late 1800’s and early 1900’s, in many cases, did not utilize the full optical range of their scanning disks for this very reason. *Id.* at 5:49-54. Instead, a dark colored shield would cover most of the circular scanning disk displays, and a small window cut in the shield would usually frame a small area toward the outside of the disk, where linear scanning velocities were the greatest, with the window permitting a small portion of the scanning disk to be visible, and the image or television program to be synchronized to appear in this window. *Id.* at 5:54-60. In essence, pre-WW2 POV TV or “scanning disk” systems would cover the majority of the rotating circular object and leave a small notch at the top side of the circle for viewing the small area of the circle that could be used for display. *Id.* This was usually a rectangular notch cut between the 11:00 and 1:00 position, as this was the only useful part of the display due to the outside of the circle having a larger perimeter, and, thus, higher speed, than the

center of the circle. *Id.* The dark colored shield that covered the majority of the scanning disk essentially prevented the observer from viewing areas that were optically distorted or incapable of displaying visual imagery, as was the axis of rotation and the areas proximal thereto. *Id.* at 5:60-64. Further yet, the conventional technologies do not disclose or suggest a rotational display device which operates in conjunction with a motor vehicle, nor do they disclose any of the numerous variations and enhancements to wheel mounted display systems that are described and disclosed by the inventions of the Patents-in-Suit, including that none disclose a rotational display system for displaying both cylindrical and planar type displays in a single apparatus and/or providing a rotational display system which shows pre-defined and/or user-selected images, text, and/or video on a rotating display device (such as a vehicle wheel, rotating toy, helicopter blade, etc.), including via, *inter alia*, integrating multiple unique lighting technologies (including, *e.g.*, a rotatable assembly comprising at least one lighting assembly), computer systems, controller systems, switching systems, mounting and support systems, information delivery systems, and power supply systems (including, *e.g.*, power supply control mechanism) to display information on a rotating plane of the rotating display device, including via mapping the image to corresponding mathematical coordinates and toggling illuminating elements to create a POV image. *Id.* at Abstract; 1:36-60; 2:15-28; 2:47-3:7; 3:44-67; 4:18-6:15; 6:25-7:36; Claims of the Patents-in-Suit; *see also* Claims of the '813 Patent, '028 Patent, & '389 Patent.

92. In view of, and in order to address, the issues in the conventional art noted herein, and in the disclosures of the Patents-in-Suit, the Patents-in-Suit disclose, *inter alia*, integrating multiple unique lighting technologies (including, *e.g.*, a rotatable assembly comprising at least one lighting assembly), computer systems, controller systems, switching systems, mounting and support systems, information delivery systems, and power supply systems (including, *e.g.*, power supply control mechanism) to display information on a rotating plane of the rotating display

device, including via mapping the image to corresponding mathematical coordinates and toggling illuminating elements to create a POV image for at least:

- 1) a high-quality rotational display apparatus in combination with a vehicular wheel to provide ornamental and functional displays;
- 2) a rotational display apparatus having the capability of producing a true color images that are substantially equivalent to that of a modern day TV or high-quality computer monitor;
- 3) a rotational display apparatus that is capable of displaying both cylindrical and planar type displays in a single apparatus;
- 4) a rotational display apparatus which extends to the illuminating elements to the center of the wheel to allow center-crossing of images;
- 5) a rotational display apparatus in combination with a vehicular wheel capable of displaying text and images across a linear bottom line;
- 6) a rotational display apparatus in combination with a display device such as a vehicular wheel capable of providing virtual headlight, tail light, brake light, and directional signals;
- 7) a panel display device such as a fold out communication device with a rotational scanning display apparatus to provide message communication and image displays;
- 8) a panel display device having the capability of producing a true color scanned image;
- 9) a panel display device which extends the illuminating elements to allow center-crossing of images; and
- 10) a display device with a rotational scanning display apparatus to provide message communication and image displays in three dimensions.

Id. at 6:4-50.

93. These inventions developed from, *inter alia*, Mark's desire to use rotating LEDs to develop educational STEM toys, display high contrast visual information for persons with visual

impairments and sensory limitations, and/or show digital pictures, such as automotive company logos, on the wheels of radio-controlled cars and equivalently from the rotor of a helicopter. *Id.* at 16:10-23. Thusly, the disclosures of the parent '813 Patent, and all of the Patents-in-Suit, include an embodiment that is vehicularly related, using the technology for directional signals, brake lights, and signage that could make bright 3-D turn signals and brake lights float above or beside a vehicle for enhanced visual recognition. *See id.* at Figs. 1 & 2. Another embodiment of the parent '813 Patent discloses additional, emergency vehicles such as police cars, fire trucks, and ambulances, also incorporating the claimed technology. *Id.* at 14:66-15:9.

94. Moreover, the disclosures of the Patents-in-Suit expressly recognize that “[a]ll aspects of the above-described rotational display system can be manufactured with infinite variety.” *Id.* at 15:15-16. Indeed, shortly following the first disclosures thereof in the application for the parent '813 Patent, children applications explicitly covering non-vehicular devices (such as bicycles, cars, advertising devices, greeting cards, and other toys) were also granted. *See, e.g.*, claims and disclosures of the '214 Patent, '108 Patent, '028 Patent, & '389 Patent.

95. The “SUMMARY” section of the exemplary '108 Patent states, in part, as follows:

The present invention provides a system which integrates unique lighting technologies, switching systems, mounting systems, information delivery systems and power supply systems to provide a display device such as a vehicular wheel, greeting card and popup book to provide an advanced, high-quality visual display apparatus. These technologies, and their many unique applications, provide for a novel and useful series of video display devices that are small, lightweight, efficient and have the capability of producing a clear, bright, high definition image that is equivalent to that of a modern day TV or high-quality computer monitor. Further applications of the disclosed technologies allow the installation of compact rotary video displays in numerous applications where rotary display devices are equipped with the disclosed technologies to display visual images, videos and text while rotating. The compact, energy efficient, high optical quality technology disclosed herein is relatively inexpensive to mass produce and can be applied to many unusual locations. The primary application for rotational scanning systems discussed herein is an electronically controlled display system disposed upon or made integral to a motor vehicle wheel with both ornamental and functional applications. The compact, energy efficient, high optical quality technology disclosed herein is relatively inexpensive to mass produce and can be applied to many forms of display

devices such as vehicle wheels, greeting cards, popup books, regular books, magazines and the like.

...
The computing device transfers information regarding the data to be displayed to a rotatable assembly which includes a controller and an illuminating assembly. The illuminating assembly includes a plurality of illuminating elements. The illuminating elements are synchronized by the controller to light-up specific elements of the assembly at specific times and/or positions during rotation. This causes the rotatable assembly to display predetermined image(s), text, animations or other visual information that is pre-loaded, programmed or otherwise provided to the controller from the computing device.

...
In further embodiments the instant invention may be utilized for use as a display system in rough service environments such as on helicopter main blades, tail rotors, impellers, turbines, machine tools or rotating components in manufacturing systems and engines.

The system is preferably configured for connection to receive image display information from a portable or stationary computing device that includes hardware and/or software, to provide, import, manipulate, store and selectively display visual information of the user's choice. Such computing devices may include, but should not be limited to, palm sized computing devices, portable video game systems, laptop computers, cellular phones, audio systems, navigation systems, vehicle electronics, mobile video systems, multi-function displays or other devices that typically employ a visual display. The user may effect the data transfer or a sales person at a store may effect the data transfer to provide a personalized message in the displayed image(s).

The computing device transfers information regarding the data to be displayed to a rotatable assembly which includes a controller and an illuminating assembly. The illuminating assembly includes a plurality of illuminating elements. The illuminating elements are synchronized by the controller to light-up specific elements of the assembly at specific times and/or positions during rotation. This causes the rotatable assembly to display predetermined image(s), text, animations or other visual information that is pre-loaded, programmed or otherwise provided to the controller from the computing device.

'108/6:53-8:25.

96. Further, the disclosures at the hearts of the Patents-in-Suit include, *inter alia*, the first mathematical hardware and software processes for converting traditional electronic images based on an X,Y coordinate systems to a series of images based on a polar coordinate system with an angular degree value, radius distance value, and associated red, green, and blue ("RGB") brightness values. *See id.* at 12:25-13:24. This meant that all popular electronic images or movie formats, originally intended for rectangular screens, could now have their data automatically and

instantaneously converted to data that could be electronically understood, interpreted and displayed by a group of spinning LEDs to create a clear, level, stable image. *Id.* at 13:4-40. All one has to do is code the disclosed process in the computer language of their choice. Disclosing this process of image and motion picture conversion via trigonometry, and the addition of additional mathematical values, and associated hardware to transmit, store, and receive these numerical values, also meant that the group of rotating LEDs were now capable of displaying a movie-quality motion pictures or photographs; something previously impossible on all prior art rotating POV devices. *See id.*

97. Tabular data, such as letters, numbers, and special characters, such as early ASCII standards, had formed the basis for computer programming. *See id.* at 2:12-56. Regardless of what programming languages or structures are employed in a system, prior to the underlying technology disclosed in the Patents-in-Suit, nearly all data produced on every electronic device worldwide was displayed on a rectangular screen (an exception being radar screens). *See id.* at 12:40-52. A rectangular screen is an array of illuminated pixels arranged as addressable points in a Cartesian plane. *See, e.g., id.* at 11:19-52 & 14:23-65. An X,Y coordinate pair coupled with color intensity values for RGB can illuminate a single pixel with a precise color on a rectangular screen. *See, e.g., id.* at 11:19-14:65. This information can be extracted directly from the digital information native to the programming. Data to display any picture upon any rectangular screen was (within the context of a hardware and software standards such as PAL or NTSC) a full set of X,Y coordinates representing all lighted coordinates (pixels) on a TV screen in conjunction with a RGB brightness value assigned to each lighted pixel. *See id.* at 13:33-40. The combination of these formed the digital images shown on any rectangular screen. *See id.* at 13:64-14:42. To make it a movie, the process is repeated thirty or more times each second (for all pixels on the screen) to keep changing the picture. As the human eye, optic nerve, and optical cortex are collectively slower than the speed

at which the pictures on the screen are electronically changed, the human brain seamlessly blends these individual pictures into a single motion picture, known as POV. *See id.* at 1:53-58 & 13:56-63.

98. In the early 2000's, a typical new desktop PC had 128 or 256 Megabytes of RAM (not gigabytes), meaning that, at the time of the inventions of the Patents-in-Suit, the position sensors, encoders, hall effect sensors, etc. that comprised a spinning POV LED display, would have likely maxed out the capability of most desktop computer processors. In the early 2000's, given hardware and processor limitations, and the lack of commercially available POV software, a person who coded their own POV video conversion based on processes disclosed in the Patents-in-Suit, would notice that the video quality limitations would depend on the radius of the rotating LED POV device, number of LEDs, motor speed, and ability of the computer processor to coordinate the LED timing based on angular position of the display. It is important to note that at least in the early 2000's, prior to the processes claimed by the Patents-in-Suit, no commercially available programs were available to program POV displays, and no user interfaces (other than the pictures on the POV itself) were available to select, edit, and/or adjust electronic images intended for display on a POV. Indeed, smartphones and tablets were not available, and, thus, no apps existed for these devices, nor were there any capable applications compatible with Windows, Mac, or Linux available to download with connectivity to a POV device. Thus, the ability to create such a technology was heavily dependent on the creator's understanding of math, physics, electronics hardware, and programming. Furthermore, wireless communication protocols specific to consumer electronic devices were in their infancy, largely still under development. As a result, conventional devices at the time failed to consider the use or implementation of the inventive processes disclosed and claimed in the Patents-in-Suit.

99. Thus, at the time of the disclosures of the Patents-in-Suit, it was just barely possible,

if at all, to implement such processes on a desktop computer with a small size LED POV display by an individual highly skilled in math, physics, digital hardware and programming; however, as part of the inventiveness of the Patents-in-Suit, the disclosed mathematical processes were intentionally designed as scalable, and predicted that processor speeds, data processing capabilities, and RAM would continually grow as computers, sensors, portable devices, hardware, and LEDs continually shrank in both physical size and power consumption. The inventions of the Patents-in-Suit further predicted that power storage devices (such as batteries and capacitors) would continue to decrease in size and increase in power density in watts per unit of mass. The inventions of the Patents-in-Suit further predicted reasonable and foreseeable expansion in wireless communication capabilities, speed, and bandwidth, and equivalent growth of wired data communication standards, such as USB. Thus, the mathematical processes and associated hardware-coupled feedback systems disclosed in the Patents-in-Suit allowed for the creation of this new and visually appealing technology through a level of foresight uncommon even among those possessing knowledge of multiple scientific disciplines.

100. Thusly, the subject disclosures changed and improved POV technology, including by allowing a rotating group of LEDs to display a clear, level, true color image, equivalent to a monitor, while connected to a data source capable of allowing the user to select pictures and videos to be displayed. *See id.* at Abstract; 1:36-60; 2:15-28; 2:47-3:7; 3:44-67; 4:18-6:15; 6:25-7:36; Claims of the Patents-in-Suit; *see also* Claims of the '813 Patent, '028 Patent, & '389 Patent. This has subsequently allowed POV rotational displays to grow in appeal based upon the capacity to display high-quality 2-D and 3-D images. *See id.*; *see also* '108/5:39-42, 7:39-44, 8:11-25, 19:24-31, 19:44-20:4, & 22:42-49; Figs. 17-26. Including as noted herein, this was, *inter alia*, a result of increased computer and component processing speeds, increased component memory, brighter and more efficient LEDs, smaller and faster electric motors, and higher energy density power supplies,

batteries, and capacitors.

101. Indeed, as processor speed increased, RAM increased, hardware got smaller, batteries got lighter and specialized CAD/CAM software for PC board design became affordably available or free to the masses (at least in part thanks to the community PCB firms, the open-source movement, and certain other programs). These factors, which removed the formidable innovation barriers, cost barriers and large Minimum Order Quantities long-established by large electronics manufacturers meant that individuals could, utilizing the claimed processes of the Patents-in-Suit, design and fabricate their own PC board and digital circuits utilizing POV technology and rapidly bring them to market. Therefore, the claimed technology of the Patents-in-Suit increased exponentially in popularity, building upon the hardware and mathematical processes disclosed in the Patents-in-Suit, first by the DIY community, and then emulated by large corporations on larger commercial scales.

102. As a result, the claimed inventions of the Patents-in-Suit have advantages over conventional systems, devices, and apparatuses, including that they disclose, *inter alia*, a rotational display system for displaying both cylindrical and planar type displays in a single apparatus and/or providing a rotational display system which shows pre-defined and/or user-selected images, text, and/or video on a rotating display device (such as a vehicle wheel, rotating toy, helicopter blade, etc.), including via, *inter alia*, integrating multiple unique lighting technologies (including, *e.g.*, a rotatable assembly comprising at least one lighting assembly), computer systems, controller systems, switching systems, mounting and support systems, information delivery systems, and power supply systems (including, *e.g.*, power supply control mechanism) to display information on a rotating plane of the rotating display device, including via mapping the image to corresponding mathematical coordinates and toggling illuminating elements to create a POV image. *Id.* at Abstract; 1:36-60; 2:15-28; 2:47-3:7; 3:44-67; 4:18-6:15; 6:25-7:36; Claims of the

Patents-in-Suit; *see also* Claims of the '813 Patent, '028 Patent, & '389 Patent.

103. In at least some embodiments, this includes the use of, *inter alia*, a computer, a controller, and/or a power delivery means as part of the system, including so that the user is able to select the specific visual image displayed by the system, including via the uploading and/or transferring of the image data information from the computer to the rotating assembly, including via the controller, meaning the user may use their own images with the system and the system provides a more dynamic experience to the user, including by mapping the image or other media to corresponding mathematical coordinates. '108/17:17-36. To the contrary, conventional systems were limited to pre-programmed images and/or devices with low-resolution which required users to manually develop, code, and type a lengthy computer program to turn the lighting elements on and off. *See id.* at 2:61-67 & 3:57-61. However, included as noted herein, these systems failed to provide sufficient customization options and resources for the user to fully display any image the user wished, nor did they permit the user to simply use the user's own images without the need for painstakingly creating a low-quality image by toggling a handful of lighting elements. *See id.* Thus, an updated system, architecture, and process was needed, and the Patented Inventions provide such systems which solve these problems. *See, e.g.*, Claims of the Patents-in-Suit.

104. In some embodiments, this includes the use of, *inter alia*, a rotatable assembly with multiple illumination assemblies and corresponding illumination elements and/or a controller, including so that the systems are permitted to display true color and/or multi-dimensional images, and the user is able to display images in a quality aligning with what was seen in conventional display systems (*e.g.*, TVs, movie theaters, etc.). *See* '108/6:8-11. To the contrary, including as noted herein, many conventional systems had monochromatic image output, with those comprising colored outputs being very limited in the spectrum and scope of colors available. *See id.* at 3:32-36, 3:54-57, & 5:12-17. But, as a result, these conventional systems were lacking the necessary

illumination elements and controllability in order to properly display such high-quality images, and, instead, had limited ability to display images. *See id.* Thus, an updated system and architecture was needed, and the inventions of the Patents-in-Suit provide such systems which solve at least these problems. *See, e.g.*, Claims of the Patents-in-Suit.

105. In at least some embodiments, this includes the use of, *inter alia*, a computer, a controller, a rotatable assembly, an illuminating assembly comprising at least one illuminating element, and/or a power delivery means as part of the system, including so that the image during the rotation of the device is shown in a high-quality POV image which represents the selected media, without said POV image having gaps therein and/or being warped, distorted, and/or bent around, and/or relative to, the horizontal ground plane relative to the POV image – *i.e.*, the user can display an image without having the image bend or warp around the axis of rotation nor have gaps, or other missing areas of the image, due to the shape of the device and its circular rotation. *See id.* at 5:60-64 & 12:35-40. To the contrary, conventional systems provided lower quality POV images, were unreliable, and had limitations on the POV image, including that these conventional devices were often sensitive to external interference, such as magnetic fields, and limited to shapes which left large areas of the image not displayed, such as the center of a circular area causing warping of the selected image and/or gaps in the POV image near the axis of rotation. *See id.* However, including as noted herein, these systems were less than ideal for a user who wished to display full images throughout the area of rotation and those who sought a device that was able to work in any area under any conditions, including because they failed to provide a way of plotting the selected image onto corresponding relative coordinates for use by the device to display a high-quality, more complete POV image. *Id.* at 12:16-52 & 13:41-55. Thus, an updated system, architecture, and process was needed, and the Patented Inventions provide such systems which solve these problems. *See, e.g.*, Claims of the Patents-in-Suit.

106. Including as of the priority dates of each of the Patents-in-Suit, as noted herein, and in the disclosures of the Patents-in-Suit, there have been various, albeit vastly inferior, means outside of the claimed inventions for achieving the ends of a rotational display system for displaying both cylindrical and planar type displays in a single apparatus and/or providing a rotational display system which shows pre-defined and/or user-selected images, text, and/or video on a rotating display device (such as a vehicle wheel, rotating toy, helicopter blade, etc.), including via, *inter alia*, integrating multiple unique lighting technologies (including, *e.g.*, a rotatable assembly comprising at least one lighting assembly), computer systems, controller systems, switching systems, mounting and support systems, information delivery systems, and power supply systems (including, *e.g.*, power supply control mechanism) to display information on a rotating plane of the rotating display device, including via mapping the image to corresponding mathematical coordinates and toggling illuminating elements to create a POV image. *Id.* at Abstract; 1:36-60; 2:15-28; 2:47-3:7; 3:44-67; 4:18-6:15; 6:25-7:36; Claims of the Patents-in-Suit; *see also* Claims of the '813 Patent, '028 Patent, & '389 Patent.

107. Including as noted herein, and in the disclosures of the Patents-in-Suit, at the time of the Patented Inventions, conventional approaches to displaying user-selectable images, text, and/or video on a rotating display device in full color and without bending the image about the axis of rotation using conventional technology were limited.

108. In at least some embodiments, the Patented Inventions comprise rotational display systems 12 (*e.g.*, a POV device) that display user-selectable visual information, such as images, text, numbers, symbols, animations, videos, and the like while the system is mounted or otherwise incorporated into a rotating device and during rotation of said device, wherein the general components of these systems include at least a computer 14 (*e.g.*, a user's desktop, laptop, tablet, mobile device, etc.), a rotatable assembly 24 (*e.g.*, a collection of lighting devices within a

housing), and a means of power delivery 20 (e.g., a battery) to the rotatable assembly. '108/9:47-53 & 58-61. As noted herein, such systems, while able to be combined or split in many ways and not limited to specific uses, are described in terms of being attached to vehicle or other wheels, including, for example, as shown in exemplary system shown in Figures 1 and 5 of the '108 Patent:

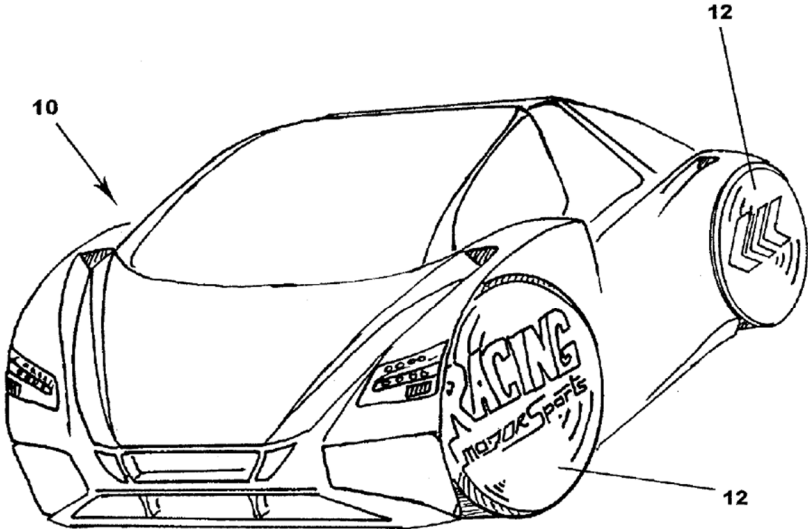

FIGURE 1

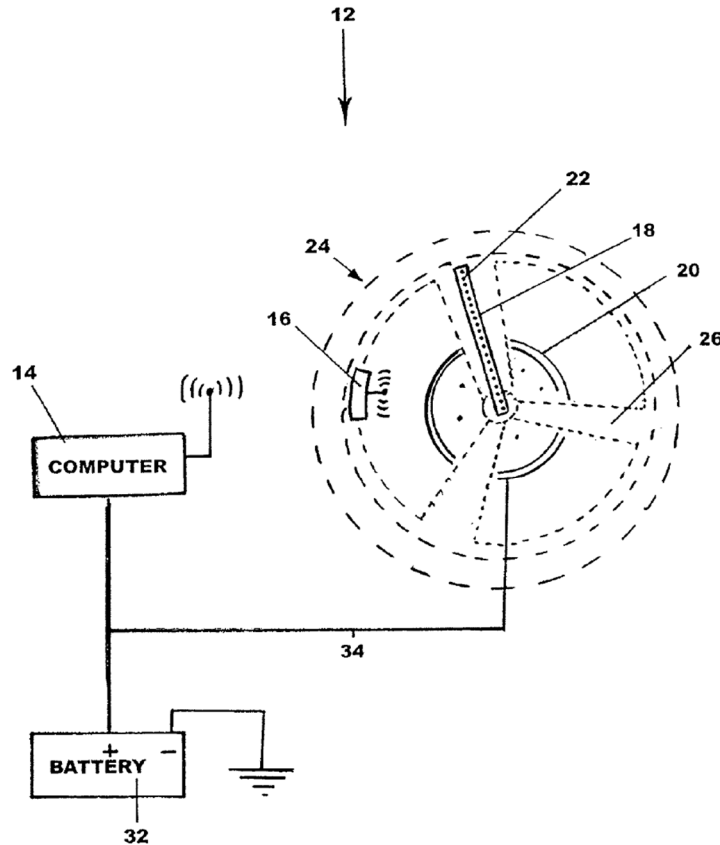

FIGURE 5

Id. at Fig. 1; 9:53-58; *see also id.* at Figs. 2-10.

109. In at least some embodiments, computer 14 provides for storage and recall of images which are wirelessly transferred to rotatable assembly 24 which includes controller 16 and illuminating assembly 18. *Id.* at Figs. 5-6; 9:62-65. More specifically, computer 14 is a microprocessor type device that allows users to upload and store images, videos, logos, text, and the like by accepting various software file formats (*e.g.*, JPEG, BMP, AVI, Quicktime, etc.), including via popular hardware methods of transferring stored digital information (*e.g.*, CDs, DVDs, flash memory cards, USB ports, wireless connections, optical connections, IR ports, etc.). *Id.* at 9:65-10:7. Computer 14 provides a high level of user selectivity and may include enhancements such as touch screens, digital pads, keyboards, and suitable combinations thereof,

which allow a user to select which images or videos should be displayed on the rotational display system 12 during operation thereof. *Id.* at 10:7-12. Computer 14 electrically communicates with rotatable assembly 24 via controller 16, which is preferably positioned within rotatable assembly 24, such as, for example, that shown in Figure 5 of the '108 Patent. *Id.* at 10:12-16; *see id.* at Fig. 5.

110. In at least some embodiments, controller 16 may include circuitry suitable to accept communications from computer 14 via radio, optical transmission, electrical transmission, wireless communications, such as via micro transmitters and receivers, or other communication method permitting two-way communication between computer 14 and controller 16. *Id.* at 10:16-25. Controller 16 further includes circuitry capable of synchronously illuminating elements 22 of illuminating assembly 18, thus producing a visual output. *Id.* at 10:25-27. More specifically, the hardware and/or software utilized within controller 16 will vary based upon the type, size, and/or quantity of illuminating elements 22 included therein, as well as the rotational speed of rotatable assembly 24, and the complexity of text, numbers, images, and/or animations chosen by the user to be displayed through rotatable assembly 24 via illuminating assembly 18. *Id.* at 10:28-33.

111. In at least some embodiments, controller 16 has the primary role of receiving information regarding the desired display from computer 14 and synchronously energizing individual illuminating elements 22, clusters, or pixels within illuminating assembly 18 to produce one or more predetermined and/or user-selected images. *Id.* at 10:33-37. In order to properly synchronize illuminating elements 22 for illumination at specific positions within the rotation of illuminating assembly 18, controller 16 must know, *inter alia*, its position with respect to a predetermined point within the rotation, including via a means of synchronization that perceives the passing of one or more positions during rotation of rotatable assembly 24, including via a position sensing device or apparatus (*e.g.*, gyroscopes, magnetic sensors, Hall Effect sensors,

lasers, infrared devices, radio-frequency devices, optical/reflective tachometers, laser tachometers, mechanical position (rotary) encoders, electromagnetic sensors, accelerometers, displacement sensors, and/or suitable combinations thereof), where the simplicity, complexity, and/or overall effectiveness of which may vary depending the application. *Id.* at 37-53. Such position sensing devices and apparatuses may further comprise one or more Programmable Logic Control (“PLC”) technologies and/or Computer Programmable Logic Devices and Field Programmable Gate Arrays, including in use with micro-scale radio transmitters coupled with miniature multi-axis position sensors to permit utilization of wireless technologies for such sensing operations and provide reliable rotational display synchronization hardware that is rugged and designed to operate in a variety of physically and electrically demanding environments. *Id.* at 10:53-11:18.

112. In at least some embodiments, illuminating assembly 18 may have numerous inherent variations in size, length and resolution (resolution or definition is the number of actively switchable or addressable illuminating elements per unit of area; the higher number indicates that a higher quality image can be displayed) and illuminating elements 22 therein may comprise many different illumination devices (*e.g.*, LEDs), organic light emitting diodes, electroluminescent strips, LCDs, thin film transistor liquid crystal displays, plasma displays, small light bulbs, and/or suitable combinations thereof), and may be used to form an appropriate display for predetermined applications, with each having different characteristics, advantages and disadvantages. *Id.* at 11:19-46. Thus, the general definition of illuminating assembly 18 is understood to apply to devices where light emitting elements 22 are connected and integral at a high density, miniature, microscopic, and/or molecular level, such as illuminating elements 22 or combinations of illuminating elements 22 described above. *Id.* at 46-52. Regardless, individual elements of illuminating assembly 18 must be controllable to appropriately illuminate at predetermined positions during rotation, thus forming a predetermined image. *Id.* at 11:31-34.

113. In at least some embodiments, a further part of the Patented Inventions comprises power delivery means 20 (e.g., batteries, solar panels, rechargeable systems, magnetic field generation, high-frequency transformer, and hardwired systems that employ slip-ring contacts or electrical commutator and brush assemblies, etc.) which can provide adequate electrical power delivery to rotating assembly 24 and which may be partially present on the moving (rotating) portion of the system. *Id.* at 11:53-12:24.

114. As it is an object of the instant invention to display life-like images on a rotational display system without bending the horizontal ground plane around the axis of the display system, it is necessary to understand the operation of the prior art systems that wrap the horizontal plane around the axis of rotation. As noted herein, unlike the Patented Inventions, prior, conventional devices which displayed images via a linear methodology, including via the use of X,Y pixel or dot coordinates. *Id.* at 12:36-13:40. For devices such as the Patented Inventions, for true color output, the hardware would have to support triplicate electronic processing of each set and the rotational display system would also require tri-color separately addressable illumination sections to visually output the data. *Id.* at 13:41-44. Although the electronic hardware and software was readily available to accomplish this at the time of the inventions of the Patents-in-Suit, no such devices had yet been created. *Id.* at 13:45-55. Further, in order to create such true color images, specific timings and locations for the illuminating elements must be considered, including for the mapping thereof by the rotational display system. *Id.* at 13:56-14:22. In addition to the creation of X,Y coordinates, this mapping further comprises converting the X,Y coordinates to polar coordinates, including by defining the distances from the axis of rotation where a point, pixel or LED must illuminate at a predetermined angle to display a predetermined frame of visual output. *Id.* at 14:23-37. With the rotation angle and distance from the center known for any set of points that combine to define an image, it is possible to display an image or text across the full face of

the circle. *Id.* at 14:37-40.

115. More specifically, including as noted hereinabove, any electronic image intended to be displayed on traditional rectangular screens (including all formats of digital images generated by digital cameras in any device) utilize Cartesian X,Y coordinates to identify which pixels to illuminate at a specific location on a screen (and what color and time duration). *See id.* at 13:33-14:42. The combination of all possible pixels on a screen receiving this data allows a rectangular screen to generate the beautifully clear color images or videos we see on a rectangular screen. *Id.*

116. As a rotating POV display moves in a circular motion and relies upon one or more groups of LEDs, providing the POV display with Cartesian (X,Y) coordinate based data, intended for a rectangular screen, causes the images to distort in a circle. *Id.* This is because the LEDs closest to the center of the circle only rotate a short, linear distance while the LEDs toward the outside of the circle go a much longer linear distance. *See id.* at 14:23-42. As X represents the horizontal axis on a number line and Y represents the vertical axis, using the Cartesian X,Y data on a POV device necessarily causes the image to be distorted when converted into an image displayed in a circle, making quality images near-impossible to display, including because X coordinates with low corresponding Y values (*i.e.*, close to the center of the circle) are compressed into the short rotating distance near the rotating axis at the center of the circle. *See id.* Accordingly, higher values of Y displayed on the X number line are located more toward the perimeter of the circle, and, thus, become excessively elongated along the outside edge. *See id.* As each pixel in a rectangular screen is just an X,Y coordinate pair, this limitation means that (until the processes disclosed by the Patents-in-Suit) every popular format of transmitting and/or saving digital images, meant for a rectangular screen, were completely incompatible with reproducing an image on an array of rotating lights which, as noted herein, is a circular function.

117. Accordingly, when early POV developers and hobbyists utilized the digital data

from popular digital video file formats for rectangular screens and pushed the data feed of a rotating array of LEDs, the text displayed circularly distorted, so letters were upright at the top of the circle, upside down at the bottom of the circle and sideways or tilted at all other positions on the circle. This was the case with early POV devices that were unable to display quality, level pictures or text messages. This broad limitation, combined with several hardware limitations, hindered POV development, and, thus, early 2000's POV devices were limited to only a few novelty products, had no image select-ability, and no import ability. Additionally, no commercial software existed at the time of the inventions of the Patents-in-Suit for these devices, as they were viewed as only a novelty with limited potential. As the few POV novelty device manufacturers largely accepted this mathematical and physical limitation as part of their devices, there was little incentive to innovate or improve existing POV displays. Moreover, there were also no standards for POV systems at the time, as the small number of inventors, developers, and manufacturers working in this field all wrote their own, proprietary and tailored software based on the specific chipsets they used for their hand made prototypes. The image being distorted in a circle as a result of all programming in the conventional devices in use at the time of the filing of the Patents-in-Suit based on Cartesian coordinates, thus inheriting its limitations.

118. Contrary to the convention at the time, the inventions of the Patents-in-Suit recognize that converting an electronic image (or series of images) intended for a rectangular screen to an electronic image that can be displayed on a spinning screen required a new approach. Including as disclosed in the Patents-in-Suit, in order to display high-quality, level, and clear images, rotating LED POV screens must require all X,Y Cartesian coordinates for every single pixel on a rectangular screen be converted to equivalent polar coordinate while simultaneously carrying over the color intensity information for how bright to make the respective RGB colors that comprise each pixel; and that this process must repeat for each frame in a motion picture or

other media displayed by the POV device.

119. The Patents-in-Suit further disclose, *inter alia*, a process for transforming a point (pixel) from its rectangular coordinates (X,Y) to their respective values on a corresponding polar coordinate system with a radius (r) and an angle (θ). *See, e.g.*, 14:56-65 & 19:24-36. This conversion allows the lighted point or pixel (normally displayed on a rectangular screen) to be expressed in terms of distance from the center of the rotating axis (*i.e.*, the radius, r) and the angle at which an LED must light up (*i.e.*, the angle, θ). *See id.* In turn, this allows each pixel, or lighted dot, to be displayed by the spinning group of LEDs by taking the data intended to otherwise be displayed via a rectangular screen and feeding it into a trigonometric formula which would tell the group of rotating LEDs which LED to light as it passed through a particular angle in its rotation.

120. More specifically, the Patents-in-Suit disclose using the X,Y coordinates associated with each screen pixel as the input to the usual X,Y coordinates in Pythagorean theorem $r = \sqrt{(x^2 + y^2)}$ to compute the radius distance, thus telling the rotating POV screen which rotating LED to light based on its respective, calculated distance from the rotating axle, which is the distance to the center of the circle (as each rotating LED is its own unique radius based on its position on a rotating circuit board, fan blade, bike wheel, etc).

121. Furthermore, the Patents-in-Suit disclose using the same X,Y coordinates for each pixel to compute the exact angle (θ) at which each rotating LED illuminates by using trigonometric functions, whereby illumination angle θ for any rotating LED = $\arctan2(y, x)$ whereby x and y are the coordinates for each lighted pixel, as pulled from the corresponding display data intended for a rectangular screen. In specific $\arctan2(x,y)$ measures the counterclockwise angle between the positive X axis and the rectangular pixel point (X,Y). The angle (θ) numerical output is measured in radians, and can be converted to degrees, so that a circular rotating POV display can easily be programmed as a 360 degree system, familiar to most programmers and engineers. For higher

optical resolution, extra decimal places can be added when making a user interface for programming a POV (such as 360.0 degrees), giving each rotation three thousand and six hundred possible illumination angles for every one spin of an LED array (assuming equivalent computational capability and resolution within the typical POV hardware would support the higher resolution; such as position sensors, RPM counters, and associated voltage controls and power distribution to each LED).

122. The Patents-in-Suit further disclose that color data, such as brightness values for respective RGB values for the image, are carried over so that the RGB color intensity information native to the X,Y coordinate pixel color data in digital files intended for any rectangular screen are attached to each of the radius and angle values that cause each LED to illuminate at a specific angle in a rotating POV display. Essentially the color brightness information for RGB values native to digital picture or movie data (intended for a rectangular screen) are carried over and attached to each computed pixel (polar coordinate), for rotating display, as computed from each Cartesian X,Y point native to all popular digital image and movie formats. Thus, this disclosed process allowed, *inter alia*, spinning LEDs to display in color instead of monochrome.

123. These aforementioned details disclosed and claimed by the Patents-in-Suit provide a rotating POV screen with a method by which all digital pictures and movies, otherwise intended for a rectangular screen, can be displayed perfectly upon one or more spinning POV screens in color with the same level of optical clarity one would expect from a rectangular HDTV screen. Essentially, by disclosing the performance of the above determinations of the radius and angle for each pixel, the inventions of the Patents-in-Suit, *inter alia*, provide for POV devices to create a virtual mapping of the image which can then be used to selectively illuminate the illumination elements to create the desired POV image.

124. Likewise, any such image to be displayed should have its coordinate sets

electronically stored in polar form, including via specific software and/or hardware for same, with such software and/or hardware interfaces having proper calibration features to properly center, tilt, and adjust any displayed images. *Id.* at 14:40-55. While such coordinate creation and conversion is not difficult, it does require more computer programming, and subsequently more memory, than an equivalent image that is displayed in wrap around mode as opposed to full face display mode, and, further, where such output is in true color, such requirements are at least tripled. *Id.* at 14:56-65.

125. The Patents-in-Suit further disclose another detail critical for adjusting the screens so that one giant picture or video can be displayed across multiple screens and so that each screen (or all screens together) know which way is up by understanding that “up” is a positive Y value perpendicular to the X axis, also referred to as a horizontal ground plane or “ground plane” in the Patents-in-Suit. *See id.* at 13:8-24. This is important because a solid circle has no up or down. For example, rotating a solid green circle clockwise or counterclockwise gives the same picture of a green circle. The inventions of the Patents-in-Suit recognized that this limitation could hinder image quality particularly when a video or picture was shared across one or more POV displays or utilized multiple rotating LED bars to form a video or image. No consumer would likely purchase a rotating POV display that randomly tilts the image or video so it was not level to the floor/ground upon which they stand. Thus, this disclosed process references the mathematical meaning of horizontal or ground plane as a value that should be adjustable so that any POV rotating system can have its image leveled without having to physically move, relocate or rotate the hardware (such as the motor or spinning section). This also allows for a degree of safety because this digital adjustment means that nobody has to spin a high speed fan or lighted rotor close to their hand to adjust the position of a magnet taped to the back of the motor, a bike frame or any stationary object adjacent to a rotor. It also formed the basis for programming high-quality computerized user

interfaces that could adjust the image.

126. Here, the arc tangent trigonometry function, specifically $\text{atan2}(y, x)$ is a function that returns the angle (in radians) between the positive x-axis and the line connecting the origin to the point (x, y) for each pixel. The atan2 function is used to adjust the correct quadrant of the angle based on the positive or negative signs of both x and y. The Patents-in-Suit additionally disclose that the values and signs of x and y can be manipulated so that the rotating POV screen can be adjusted by quadrants, thus allowing the user to adjust which way is up in the picture or video displayed on a rotating LED POV screen. This is particularly helpful since it provided a process by which the same rotating POV screen can display properly regardless of how it is physically attached to something. For example, these disclosures in the Patents-in-Suit allow the same POV rotating LED screen to, *inter alia*, stand on a pole on the floor, hang from the ceiling, connect to a horizontal mount, be used on a bike wheel, or even float in a hovering drone, including because these disclosures of the Patents-in-Suit provide a numerical way to adjust which way is up and down, overcoming another major limitation to making high-quality images appear across one or more rotating LED POV displays. Furthermore, it improved safety by allowing display adjustment to be done remotely through software and not by having someones hand adjust magnets or buttons on the back of a spinning display, as was common in early 2000's POV products.

127. This same numerical adjustment also allows for image centering as well as zooming in or out by simply adjusting the range of values and or the distance (scale) between each digit on the x and y axis. This disclosure allowed the development of zoom and multi-image calibration for all image capable POV devices. Furthermore, the software which can perform these functions could be user interface driven so that the user could easily adjust the POV rotating displays through any common electronic device with data connectivity and a screen. Collectively, this disclosure, and those aforementioned, allowed the development of software and hardware methods for the

viewer to adjust which way was up on a circular POV screen, plus the ability to overlap images shared among multiple rotatable assemblies, zoom, calibrate, and/or center rectangular images or movies seamlessly across multiple rotating POV screens, even if the POV screens were different sizes and/or had different numbers of LEDs, and regardless of which directions they all rotate. For the purpose of spanning an image across several displays, the x axis can mathematically be extended to intersect more than one spinning POV screen thus making possible large video displays with multiple screens. In essence, the coordinates to be illuminated are shared across multiple POV screens and can overlap so that no gaps appear in the images. This also allows the use of multiple groups of spinning LEDs that have unequal lengths and are spinning in different directions to perfectly overlap clearing a seamless high-quality visual experience though scalar adjustment of the image portion delivered to each rotating POV within a multi-POV system. Indeed, these disclosures of the Patents-in-Suit collectively formed the knowledge upon which all modern POV systems are built.

128. The trigonometry conversion from X,Y coordinate pairs (Cartesian map latitude and longitude) to Polar coordinates was used by early sailors circumnavigating the seas prior to the discovery of radio navigation and electronics. *See id.* at 14:23-42. This trigonometric formula is still used in satellite communications and some flight data systems on commercial aircraft. Modifying the Cartesian to Polar coordinate conversion, and replacing the input values (like latitude and longitude) with the Cartesian data points (pixels) which, computed as a group, represents the digital image to be displayed on a rectangular screen, and rroup of rotating LEDs to show a clear stable image at any speed and to maintain a clear image even if the speed of the rotation changed abruptly. *See id.* By attaching three extra mathematical quantities to the above process (associating a brightness value, like a percentage with each of the RGB brightness values) the rotating POV display could now display in full color. Adjusting the positive and negative

number values of the Origin (point 0,0) on the Cartesian plane translated to the ability to have a reference point or reference line on any area of the circular screen via Polar coordinate conversion. *See id.* As lighted pixel positions could be set equal to any physical position on the circle with this method, the ground plane representing the horizon in a picture or movie, could be referenced to a horizontal line that was outside of, inside of, or intersecting the swept circular path of the rotating LEDs, thus making the full area of the circle useful for displaying an HDTV quality image without distortion, without bending, spiraling or twisting. *See id.* The horizon line, also described as a ground plane, was the obvious choice for calibrating a reference point for a spinning LED system displaying an upright image. *See id.* at 12:53-59. Mathematically this is setting the origin 0,0 of the Cartesian plane so that it is *not* automatically set to origin point 0,0 on the Polar coordinate system; however, this is done within the context of the aforementioned process carrying the color brightness data along with the entire graph that has been shifted and calibrated via aforementioned mathematical processes to level and calibrate one or more displays.

129. This process also allowed data to be adjusted if needed to compensate for any visual distortion that may happen. For example, a POV device displaying a picture of a square may appear to a human as a square with curved sides at low rotational speeds or a low LED flash (*i.e.*, refresh) rate due to the way the brain processes information in the optical cortex when it sees a spinning object. This is similar to the visual mechanism that contributes to dizziness. The disclosed mathematical processes provided a way to simply adjust the numbers or develop a correction algorithm to correct any visual distortion that may occur on the rotating display. Note that new high switching speeds of LED and high RPM rotors do not encounter this problem to the degree they did in the past; this is simply an example of how the mathematical flexibility disclosed in the Patents-in-Suit allows for display of high-quality images from a rotating LED array in a manner not possible prior to the information disclosed in the Patents-in-Suit. These processes overcame

all prior limitations to displaying high-quality pictures or movies from a group of LEDs rotating in one or more planes. In addition, the process disclosed allowed multiple rotating LED screens to overlap forming large screens. The aforementioned mathematical processes described simply referenced each POV rotating device in a group to a common horizon line via setting those mathematical terms equal, thus allowing seamless blending of motion pictures to form a large-scale video display from many smaller rotating screens. It also provided multiple mathematical processes for screen overlapping by allowing a single lighted point to be created by more than one single LED, meaning as one rotating blade crossed over another, both would display the lighted pixel by synchronizing the activation of their LEDs, so that even as rotating blades crossed repeatedly at high speed, no shadows, gaps or distorted areas would appear in a display comprised of multiple rotating LED POV devices.

130. All aspects of the above-described rotational display system can be manufactured with infinite variety, such as shown in Figure 11 of the Patents-in-Suit:

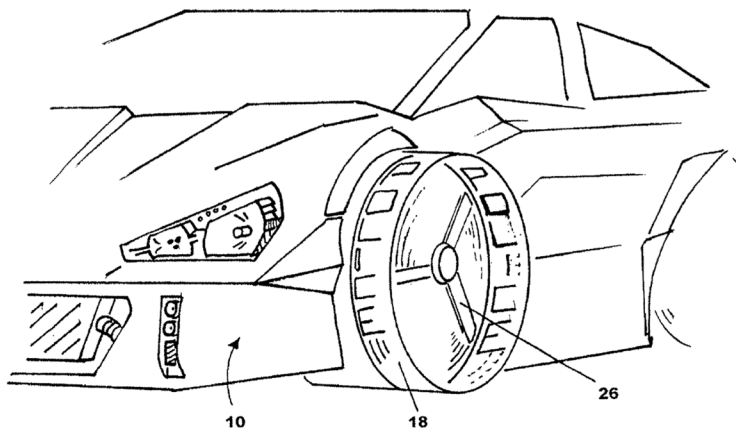

FIGURE 11

wherein an emergency vehicle may use rotational display 12 to say “police” in a forward and/or side direction or to serve as extra emergency flashers, a large truck can display a “wide load” image on the wheel display, or passenger vehicles can integrate the lighting into its existing lighting

systems, and may be done using any number systems. *Id.* at Fig. 11; 14:66-15:9; *see also id.* at Figs. 3-10; 15:10-16:55.

131. In at least some embodiments, the claimed inventions of the Patents-in-Suit may be incorporated into image display system 110 utilizing rotatable display assembly 111 to providing a plurality of axes of rotation of illuminating assembly 112, with such axes generally perpendicular to each other. *Id.* at 16:56-61. In general, rotational display assembly 111 displays visual information such as images including, text, numbers, symbols, animations, videos and the like. *Id.* at 16:61-64. In at least some embodiments, rotational display system 12 comprises the general components of computer 114 with memory 115, at least one controller 117 and power delivery means 120 to display assembly 111. Rotatable display assembly 111 preferably has controller 117 mounted thereto and includes illuminating assembly 112 that moves and carries a plurality of illuminating elements 121 preferably providing discreet light sources. *Id.* at 16:64-17:9.

132. In at least some embodiments, computer 114 provides for storage and recall of information for display during operation of display assembly 111, with such information preferably wirelessly transferred thereto, wherein display assembly 111 comprises controller 117 and illuminating assembly 112, including as illustrated in Figure 12:

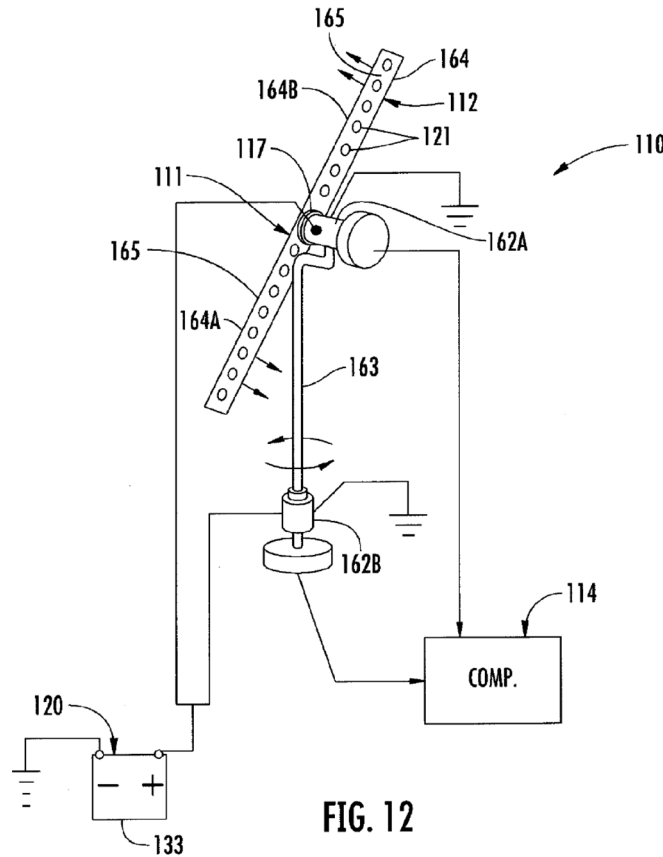

Id. at Fig. 12. Illuminating assembly 112 comprises a plurality of illuminating elements 121 operable to present illuminated image 119 as instructed by computer 114, which comprises microprocessor 122 preferably having information transfer connector 124. *Id.* at 17:15-19. In this way, a consumer, user, or salesperson may upload and store information regarding images, videos, logos, text, and the like for display by accepting various software file formats (*e.g.*, JPEG, BMP, AVI, Quicktime) or computer 114 may accept popular hardware methods of transferring stored digital information which may be provided from CDs, DVDs, various flash memory cards, USB ports, wireless connections, optical connections, IR ports, and the like. *Id.* at 17:19-28. Computer 114 may provide a high level of user selectivity and may include enhancements such as touch screens, digital pads, keyboards and suitable combinations thereof, all well known in the art, which allow a user to select which images or videos should be displayed on display assembly 111 during operation thereof. *Id.* at 17:28-34. Display system 110 may also be provided with a fixed memory

set of information to display pre-programmed information. *Id.* at 17:34-36.

133. In at least some embodiments, computer 114 electrically communicates with illuminating assembly 112 via at least controller 117, which is preferably positioned within or is suitably mounted thereto and includes circuitry suitable to accept communications from the computer wirelessly (e.g., via radio or optical transmission), including, for example, as illustrated in Figure 17:

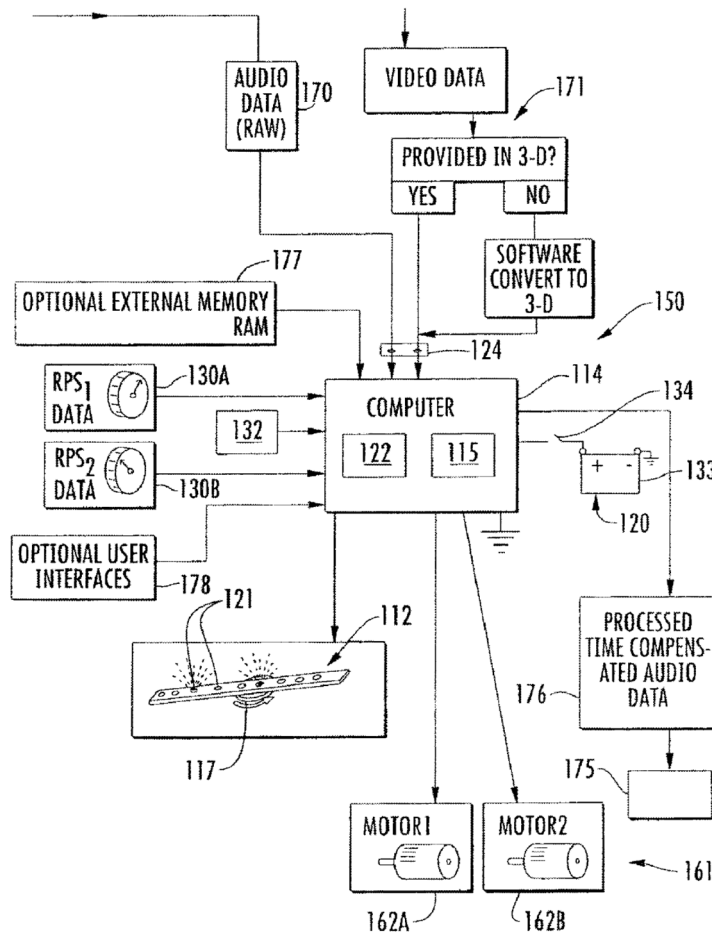

FIG. 17

Id. at Fig. 17; 17:37-43. Computer 114 and/or controller 117 know the position of illuminating assembly 112 with respect to a predetermined or reference position within the rotation, and controller 117 preferably knows the rotational position of illuminating assembly 112 (where the position system is part of display assembly 111) and includes a means of synchronization that

perceives rotatable assembly 112 passing by one or more positions during rotation of illuminating assembly 112. *Id.* at 17:43-52. Display system 110 is preferably provided with position sensors 130 for each axis of rotation, with the simplicity, complexity, or overall effectiveness thereof variable depending on the application. *Id.* at 17:52-58. Display system 110 may also be provided with one or more tilt sensing devices 132 to indicate the degree of rotation of display assembly 111 from plumb in one or more axes and provide signals to controller 117 to adjust the image display so it remains positioned at a predetermined angle of rotation from horizontal or vertical. *Id.* at 17:59-64.

134. In at least some embodiments, illuminating assembly 112 can have numerous inherent variations in size, length, and resolution (resolution or definition is the number of actively switchable or addressable illuminating elements 121 per unit of area occupied by illuminating elements 121; the higher number indicates that a higher quality image can be displayed), and the rotation of illuminating assembly 112 provides a displayed image larger than if it were motionless. *Id.* at 17:65-18:7.

135. In at least some embodiments, including as noted herein, and in the shared specification of the Patents-in-Suit, power delivery means 120 may comprise one or more batteries 133 or can include normal AC current such as from a plug-in outlet, including as illustrated in Figures 12 and 17 (shown above). *Id.* at 18:8-12. Switch 134 (*e.g.*, membrane snap contact switch or other suitable switch) is provided and is operable to selectively connect power delivery means 120 to the other power using elements and effect their operation, and may be manually operated as with a user's finger or may be configured to activate and deactivate upon relative movement of parts of image display system 110. *Id.* at 18:12-18. However, some applications may be able to use power from so-called AC household current, since mobility may not be an issue, but, regardless of the specific construction of controller 117, position sensors 130, illuminating assembly 112, interfaces, etc., there are many alternative and viable options (*e.g.*, batteries, solar panels,

rechargeable systems and hardwired systems) for power delivery means 120 that can provide adequate electrical power to display assembly 111 that may be partially present on the moving (rotating) portion of image display system 110. *Id.* at 18:18-28.

136. In at least some embodiments, including as illustrated in Figure 12 (*see above*), display system 110 includes support base 140, display assembly 111, and control system 150, where display assembly 111 is mounted to support base 140 and is operable to effect the display of selected image 119 using a lighted display and control system 150 is operable to control operation of display assembly 111. *Id.* 18:29-35. Support base 140 may be of any suitable structure and configuration and is operable to support at least display assembly 111 during operation, such as fixed or portable and preferably adapted to rest on any suitable surface (*e.g.*, counter, table, desk, or the like) and may comprise deck 141 and/or legs 142. *Id.* 18:36-41.

137. In at least some embodiments, display assembly 111 comprises illumination assembly 112 and drive system 161 which includes at least one motor 162 and preferably a pair of motors, 162A and 162B, to effect multi-axis rotation of illumination assembly 112. *Id.* at 18:42-46. Including as illustrated in Figures 12-17, illumination assembly 112 includes arm 164 mounted to motor 162A which, in turn, is mounted to support 163 and has an output shaft with an axis of rotation which for a direct drive of illumination assembly 112 is the axis of rotation thereof. *Id.* at 18:46-51. Motor 162B is coupled to support 163 to effect rotation of it in an axis of rotation different than the axis of rotation of illumination assembly 112 and, preferably, the axis of rotation of support 163 is the same as that of the output shaft of motor 162B. *Id.* at 18:51-55. The two axes of rotation of the output shafts of motors 162A and 162B are generally perpendicular. *Id.* at 18:55-57. It is to be understood that a third axis of movement can be provided for illumination assembly 112, limited only by interference between illumination assembly 112 and support 163 and which could be an oscillating movement. *Id.* at 18:57-61. Motors 162 can be any suitable motor having

enough output torque and speed (angular velocity) to adequately drive illumination assembly 112. *Id.* at 18:61-64.

138. In at least some embodiments, illuminating elements 121 are mounted to arm 164, which preferably comprises a plurality of arm portions (*i.e.*, 164A and 164B) extending in different directions, and preferably in opposite directions from the axis of rotation of arm 164. *Id.* at 18:65-19:2. Arm 164 is generally straight to provide a generally planar surface of rotation, and may comprise a plurality of arms, which comprise a plurality of arm portions, and can be configured to provide surfaces of rotation of different shapes. *Id.* at 19:2-7. It is also preferred that there be illuminating elements 121 exposed on various sides 165 of arm 164 so they may be seen regardless of the degree of rotation of support 163 about its axis of rotation. *Id.* at 19:7-10.

139. In at least some embodiments, control system 150 comprises computer 114 (and its memory 115 and microprocessor 122), position sensors 130A and 130B for illuminating assembly 112 and support 163 (providing the rotational position of rotating illuminating assembly 112 and support 163), connector 124, and controller 117, and is operable to provide signals to illumination assembly 112 and control energy distribution to its illuminating elements 121 to effect their on/off conditions and preferably their intensity of illumination at predetermined locations during movement of illuminating assembly 112. *Id.* at 19:11-21. The location of an illuminating element 121 is provided by its position on illuminating assembly 112 and position sensors 130. *Id.* at 19:21-23.

140. In at least some embodiments, drive system 161 provides for movement of illuminating assembly 112 preferably within a 3-D figure or space 167 such as a sphere. *Id.* at 19:24-26. Computer 114 knows the position of each illuminating element 121 within space 167 and can effect selective operation of illuminating elements 121 at predetermined locations or coordinates within space 167 to create a selected image 119 (*e.g.*, a still image or an animated

image). *Id.* at 19:26-31. Computer 114 can use any suitable coordinate system, such as Cartesian coordinates, polar coordinates in space (spherical coordinates), using two angles (Θ, ϕ) for azimuth and zenith and radial distance (ρ) and convert there between as needed. *Id.* at 19:31-36.

141. In at least some embodiments, illuminating assembly 112 may sweep through space 167 in the form of a sphere. *Id.* at 19:37-39. Control system 150 may comprise computer 114 with microprocessor 122 and memory 115. *Id.* at 19:40-42. Control system 150 may comprise the ability for audio and video data inputs 170, 171, respectively, may be connected to computer 114 via connector 124. *Id.* at 19:42-44. Non 3-D video input can be converted to 3-D by input device 171 or may be converted by computer 114. *Id.* at 19:44-45. Position sensors 130A and 130B provide position data to computer 114 preferably substantially continuously to effect timely output of data for control of the on/off of illuminating elements 121 of illuminating assembly 112, where computer 114 can also be operably coupled to motors 162A and 162B for control of their operation as for example control of on/off and/or operating speed (angular velocity) and/or provide audio output signals to an amplifier or directly to speakers 175 and the signals may be compressed as at 176. *Id.* at 19:46-55. Optionally, the control system may also include external memory 177 and user interface(s) 178 operably coupled to computer 114. *Id.* at 19:55-57.

142. Including as illustrated in Figure 18, in at least some embodiments, image display system 110 may be coupled, wirelessly or by wire, to a data input device such as a GPS locator 180, including so that coordinate information can be input to image display system 110 from GPS locator 180. *Id.* at 19:58-62. Display system 110 can be programmed to provide a 3-D image of a map or of the globe and then provide indicator 181 to show where the GPS coordinates indicate a location. *Id.* at 19:62-65.

143. Including as illustrated in Figure 19, in at least some embodiments, image display system 110 and, in particular, rotatable display assembly 111 providing 3-D image 119 of character

182 (*e.g.*, a jack-o-lantern) and accompanying text message 183 (*e.g.*, “HAPPY HALLOWEEN”), which may be in color. *Id.* at 19:66-20:4.

144. Including as illustrated in Figure 20, in at least some embodiments, data input 185 can be received from a radio, digital storage media like a DVD player or television station or from a simulcast of television and radio. *Id.* at 20:5-10. Audio output from image display system 110 can be output on speakers 175 and video is displayed by rotatable display assembly 111, with audio output particulars 188 displayed along with the video. *Id.* at 20:10-13. Station identification 189 may also be displayed. *Id.* at 20:13-14. This data displayed may be foreground, background, and separate from subject display 190. *Id.* at 20:14-16.

145. Truly, these technologies, and their many unique applications, provide for a novel and useful series of video display devices that are small, lightweight, efficient and have the capability of producing a clear, bright, high definition image that is equivalent to that of a modern day TV or high-quality computer monitor. The customizability of the Patented Inventions permits the specific applications and/or uses of rotatable display system to vary the specific architecture employed, images displayed, and include system parameter inputs which further allow such customization. *Id.* at 12:25-35.

146. On the other hand, including as noted herein, the convention at the time of the Patented Inventions were monochrome POV screen images (non-RGB), distorted in a circular or spiral manner, absent a user interface (internal or external to the rotating section) and without any capacity for the user to import, save or select images or their display sequence order (other than selection of basic text and ASCII characters for circularly distorted display on an early monochrome devices). Further, convention at the time had no image stabilization or very rudimentary image stabilization by mechanical hardware reference such as an internal magnetic compass (such as the I-Top toy) or a reed switch or hall sensor passing a magnet mounted external

and stationary in close proximity a rotating display (utilized by hobbyists making early 2000's POVs, at the time called "propeller clocks"). Further, the convention at the time of the Patents-in-Suit was the inability to reference the image to a ground plane based on any coordinate systems, or conversions thereof and further absence of ability for a user to define a horizontal position and for the data defining the horizontal position to be adjustable and shareable among devices. As no Cartesian or Polar coordinate based user interface were available for such early POV devices, no ability to zoom, edit, calibrate, level, or otherwise change or adapt the video output via user interface or even by simple manipulation of positive and negative values existed, thus it was not possible to adjust numerical ranges resulting in proper leveling, scaling, zooming, angling or image position for images displayed on a rotating POV device.

C. The Claims Of The Patents-In-Suit Are Directed To Patentable Subject Matter

147. Plaintiff hereby refers to, and incorporates by reference, the allegations in the above paragraphs as if set forth fully herein.

148. Including as set forth herein, the claims of the Patents-in-Suit are directed to patentable subject matter. The claims of the Patents-in-Suit, including the asserted claims, when viewed as a whole, including as an ordered combination, are not merely the recitation of well-understood, routine, or conventional technologies or components. The claimed inventions were not well-known, routine, or conventional at the time of the invention, nearly twenty years ago, and represent specific improvements over the prior art and prior existing systems and methods.

1. The Patents-in-Suit are not Directed to Abstract Ideas

149. Plaintiff hereby refers to, and incorporates by reference, the allegations in the above paragraphs as if set forth fully herein.

150. These technologies, and their many unique applications, provide for a novel and useful series of video display devices that are small, lightweight, efficient and have the capability

of producing a clear, bright, high definition image that is equivalent to that of a modern day TV or high-quality computer monitor.

151. The claims of the Patents-in-Suit neither describe nor claim a concept nor a generic method or computerized system. Instead, the claims of the Patents-in-Suit address, among other things, a persistent problem with rotational display systems for displaying both cylindrical and planar type displays at the time of the Patented Inventions, whereby systems, methods, and processes for displaying both cylindrical and planar type displays in a single apparatus was unavailable (for example, due to no commercially available software or user interfaces between a device storing a digital image and a rotating POV display device thus no picture or video file import or export capability); impossible (for example, because, prior to the Patents-in-Suit, no processes had been disclosed to efficiently, rapidly, and automatically convert data embedded in digital or analog standards made for a rectangular screen, on a large scale, considering all pixels for each video frame, to a set of instructions readily displayed by a rotating planar display array of LEDs); and/or impractical (for example, without the disclosed mathematical processes/algorithms that could efficiently, rapidly and automatically convert data within computer file standards made for rectangular displays to an instruction set for a planar display, each frame of a motion picture would have to be converted pixel by pixel for every single frame of a motion picture to generate an instruction set (such as a BIN or HEX file) or similar Cartesian based information that could be read and displayed by a planar rotating POV display). At that time, prior to the disclosed processes, this could mean hours of programming for every single frame of video. For reference, most videos run at 30 or 60 frames per second, so each second of video requires 30 or 60 frames. This translates to an 80 hour week of continuous programming to get a few seconds of video converted to properly display on a rotating POV screen. Such was the state of POV technology prior to the processes disclosed in the Patents-in-Suit. These limitations were applicable primarily to the POV

planar screen display at the time of the Patents-in-Suit and therefor exclude the ability of combining a planar display (with its inherent limitations at the time) with a less complex cylindrical display which would be connected at the perimeter of a planar display.

152. The claims of the Patents-in-Suit further address, among other things, a persistent problem with rotational display systems for showing pre-defined and/or user-selected images, text, and/or video whereby showing pre-defined and/or user-selected images, text, and/or video on a rotating display device (such as a vehicle wheel, rotating toy, helicopter blade, etc.) was unavailable (for example, since POV devices at the time did not support file transfer, file selection, or file storage (with the exception of selecting text and numerical characters stored on some early monochrome POV devices via one or two hardware buttons that would allow scrolling and selecting A-Z and 0-9 via up/down scrolling and “enter” as a hardware button), including an absence of POV file transfer software, wherein, consequently, image manipulation software for calibrating and aligning POV images were likewise unavailable); impossible (for example, no interface or file transfer software was available, because no known group of mathematical processes or algorithms were widely known to provide a reliable, accurate and infinitely repeatable, automated process to convert rectangular picture or video data, or their encapsulant files, to the raw data or files of such data that permitted a rotating array of LEDs to produce a clear level color image, in an efficient manner using the available RAM; and/or impractical (for example, due to low processing speeds, low amounts of computer RAM, lack of or limited wireless communication options that were common on early 2000’s computers limited the ability to make portable POV devices that had the capacity to store meaningful amounts of (manually converted and programmed) lighting data as to support a multi-picture or multi-video capable LED portable POV display; because POV displays with lightweight rotatable sections (thus low rotation inertia and the numerous associated benefits thereof) with restrictive battery weight considerations and relatively high current drain of the LEDs

at the time, including in combination with the above limitations); due to the high time-burden of manually programming such light output data to a POV in the absence of an automated process to convert rectangular screen data to rotating POV screen data; and due to the high cost and low availability of some blue LED products at the time).

153. Only after blue color LED technology was outlicensed after a patent lawsuit did RGB LEDs become affordable and commercially available from numerous sources. This limitation is at least one major reason why some early POV systems were monochrome or attempted to use three individual and separate LEDs for RGB. The older through-hole PCB mounted LEDs – such as the T3 and T5 LED standards (3 and 5mm diameter each) – were, respectively, low cost and bright, but were large and bulky, requiring too much circuit board space by present, modern standards. Their power consumption also mandated the use of analog voltage regulators at the time, making the rotating part of conventional POV devices heavy and dependent on external power since battery power density would not support the inefficiency of such LED driver hardware at the time. Due to the separation distances of the LED die within a through hole LED transparent lens and device package like a T3 or T5, they did not perform with the color mixing quality of a true RGB LED containing within three semiconductor dies for RGB within the same micro-sized surface mount device package with an integral reflector and heatsink. Modern day surface-mount RGB device packaged LEDs, are easily mounted close together on a PCB to provide a high definition picture on any new POV, and modern COB arrays offer even higher resolutions. However, early POV displays at the time of the Patents-in-Suit utilizing either through-hole mounted LEDs or early large RGBs requiring more physical space on the circuit board meant less LEDs per unit of PC board length, and, thus, less lighted radius points and much lower picture quality among early POV systems – even if someone took the time to manually program or convert low resolution data for display.

154. Thusly, the lack of a defined mathematical data conversion process was a primary obstacle at the time of the Patented Inventions, yet this barrier was amplified by factors such as battery weight, component weight, LED size, LED density, and color mixing ability and LED efficiency in units of light per watt, all collectively combined with processor speeds, memory storage density, and other limiting factors, including as described herein. Furthermore, at this time there was no ability to easily develop and test software or apps on popular open source platforms such as Github or Android, whereby multiple software users worldwide can collaborate on coding by distributing large scale programming tasks to various persons worldwide. GitHub, the primary place for collaboration of POV software programmers, did not come online until 2008 and took years to gain popularity with the open source programming community that largely popularized the mathematical processes disclosed in the Patents-in-Suit. Conventional circuit board manufacturers opened in 2010 and gained popularity with those hobbyists who used their rapid PCB fabrication services to prototype and test POV devices. Likewise, at the time before the processes and hardware disclosed in the Patents-in-Suit, none of these resources were available to an individual or small group who wanted to rapidly develop a high-quality POV system, as, prior to the availability of such resources provided by open source collaboration platforms such as Github, prior to on-demand US-based small quantity PCB prototyping, and prior to affordable 3-D printing, a POV developer would have had to navigate the very high barriers and costs of approaching one or more large (likely vertically integrated) manufacturers and distributors to design, engineer, test, revise, improve, and sell such a capable POV product. The Patented Inventions enable a substantial improvement in POV and/or LED display systems, including their functionality and utility.

155. Particularly, the Patented Inventions enable integrating multiple unique lighting technologies (including, *e.g.*, a rotatable assembly comprising at least one lighting assembly),

computer systems, controller systems, switching systems, mounting and support systems, information delivery systems, and power supply systems (including, *e.g.*, power supply control mechanism) to display information on a rotating plane of the rotating display device, including via mapping the image to corresponding mathematical coordinates and toggling illuminating elements to create a POV image. *Id.* at Abstract; 1:36-60; 2:15-28; 2:47-3:7; 3:44-67; 4:18-6:15; 6:25-7:36; Claims of the Patents-in-Suit; *see also* Claims of the '813 Patent, '028 Patent, & '389 Patent.

a. The Claims of the Patents-in-Suit are Directed to Innovative POV LED-Based Systems and Devices

156. Plaintiff hereby refers to, and incorporates by reference, the allegations in the above paragraphs as if set forth fully herein.

157. None of the elements that comprise the claimed systems or devices that are described in the claims of the '214 Patent are abstract. Including as described herein, and in the '214 Patent, at least the computer, controller, rotatable assembly, illuminating assembly, and wheel ('214/Figures 3-11 (and associated description in the specification)) are physical and/or tangible things known to a person of ordinary skill in the art ("POSITA") in light of the specification; and in view of the technological solutions and unconventionality noted herein. *See, e.g.*, '108/10:1-30 & 13:24-28.

158. As exemplified by claim 1, the subject claims of the '214 Patent are directed to:

1. A rotational display system including:
 - a computer for storage and recall of data representing at least one visual image;
 - a controller in wireless communication with the computer and operable to receive at least some of said data;
 - a rotatable assembly for displaying an image represented by at least a portion of the data transferred from said computer to the controller, said rotatable assembly including an illuminating assembly, said illuminating assembly being operably connected to said controller, said illuminating assembly including at least one illuminating element, said rotatable assembly being constructed and arranged for attachment to a support for rotation about an axis;
 - a power delivery means for providing power to said rotatable assembly; and

an image represented by said data transferred from said computer to the controller displayed by said rotatable assembly during rotation of said rotatable assembly, said image displayed without bending the horizontal ground plane around said axis.

'214/Claim 1.

159. Claim 1 of the '214 Patent, quoted above, is exemplary. A POSITA would understand that the language of the '214 claims is not directed merely to systems and devices for generically or conventionally displaying pre-defined and/or user-selected images, text, and/or video on a rotating display device. Rather, it comprises the specific aspects noted herein which provided the noted inventive, technological solutions to the problems faced by the inventor. Specifically, as noted herein, the claimed inventions provide inventive, unconventional, and technological solutions to the conventional problems of displaying clear, high-quality, level images or motion pictures upon or distributed between one or more rotating displays, including providing for a novel and useful series of video display devices that are small, lightweight, efficient, and have the capability of producing clear, bright, high definition images that are equivalent to that of a modern day TV or high-quality computer monitor. '108/Abstract; 6:32-53.

160. None of the elements that comprise the claimed systems or devices that are described in the claims of the '108 Patent are abstract. Including as described herein, and in the '108 Patent, at least the computer, controller, rotatable assembly, illuminating assembly, and wheel ('108/Figures 3-17 & 23-26 (and associated description in the specification)) are physical and/or tangible things known to a POSITA in light of the specification; and in view of the technological solutions and unconventionality noted herein. *Id.* at 11:53-12:15; 14:66-15:3; 16:56-17:58; & 20:17-48.

161. As exemplified by claim 16, the subject claims of the '108 Patent are directed to:

16. A rotational display system including:
a computer for storage and recall of data representing at least one visual image;

- a controller in electrical communication with the computer and operable to receive at least some of said data;
- a rotatable assembly for displaying an image represented by at least a portion of the data transferred from said computer to the controller, said rotatable assembly including an illuminating assembly, said illuminating assembly being operably connected to said controller, said illuminating assembly including at least one illuminating element, said rotatable assembly being constructed and arranged for attachment to a support for rotation about an axis;
- a power delivery means for providing power to said rotatable assembly; and
- an image represented by, said data transferred from said computer to the controller displayed by said rotatable assembly; during rotation of said rotatable assembly, said image displayed without bending the horizontal ground plane around said axis.

'108/Claim 16.

162. Claim 16 of the '108 Patent, quoted above, are exemplary. A POSITA would understand that the language of the '108 claims is not directed merely to systems and devices for generically or conventionally displaying pre-defined and/or user-selected images, text, and/or video on a rotating display device. Rather, it comprises the specific aspects noted herein which provided the noted inventive, technological solutions to the problems faced by the inventor. Specifically, as noted herein, the claimed inventions provide inventive, unconventional, and technological solutions to the conventional problems of displaying clear, high-quality, level images or motion pictures upon or distributed between one or more rotating displays, including providing for a novel and useful series of video display devices that are small, lightweight, efficient, and have the capability of producing clear, bright, high definition images that are equivalent to that of a modern day TV or high-quality computer monitor. *Id.* at Abstract; 6:54-7:14.

b. *The Claimed Inventions of the Patents-in-Suit Could not be Done Manually or in One's Head*

163. Plaintiff hereby refers to, and incorporates by reference, the allegations in the above paragraphs as if set forth fully herein.

164. A POSITA would understand that the claimed solutions could not be done manually, including because they necessarily require implementation via specialized, or specially programmed, computers, including a computer, a controller, a rotatable assembly, an illuminating assembly, a power delivery means, and, further, including at least a computer for storage and recall of data representing at least one visual image; a controller in wireless/electrical communication with the computer and operable to receive at least some of said data; a rotatable assembly for displaying an image represented by at least a portion of the data transferred from said computer to the controller; an illuminating assembly operably connected to said controller; at least one illuminating element; a power delivery means for providing power to said rotatable assembly; a support to which the rotatable assembly is constructed and arranged to be attached for rotation about an axis; and an image represented by said data transferred from said computer to the controller displayed by said rotatable assembly during rotation of said rotatable assembly displayed without bending the horizontal ground plane around said axis ('214/Claim 1 & '108/Claim 16; '108/Abstract). More specifically, these specialized, or specially programmed, computers, *inter alia*, permit the displaying of both cylindrical and planar type displays in a single apparatus and/or showing of pre-defined and/or user-selected images, text, and/or video on a rotating display device (such as a vehicle wheel, rotating toy, helicopter blade, etc.), including via mapping the image to corresponding mathematical coordinates and toggling illuminating elements to create a POV image (*see id.* at Abstract; 1:36-60; 2:15-28; 2:47-3:7; 3:44-67; 4:18-6:15; 6:25-7:36; Claims of the Patents-in-Suit; *see also* Claims of the '813 Patent, '028 Patent, & '389 Patent).

165. Nor can the claimed solutions be performed in a person's head. Furthermore, for example, the creation of a POV image via illuminating elements requires the use of physical devices, and at least the controlling of the physical illumination elements, rotating of the device to display a selected, transferred image, and delivery of power to the device, are each something that

could not be done manually or in one's head.

2. *The Claimed Inventions of the Patents-in-Suit Provide Innovative, Unconventional Concepts and Technological Solutions*

166. Plaintiff hereby refers to, and incorporates by reference, the allegations in the above paragraphs as if set forth fully herein.

167. In sum, including as noted herein, the claimed solutions of the Patents-in-Suit improved, *inter alia*, prior computer, data communication, and networking technology, including in connection with, among other things:

- a. improving and increasing the capabilities and efficiencies of the claimed inventions, including over inferior alternative means for achieving the same or similar ends of displaying both cylindrical and planar type displays in a single apparatus, thus providing for wider usage of rotational display systems;
- b. improving and increasing the capabilities and efficiencies of the claimed inventions, including over inferior alternative means for achieving the same or similar ends of pre-defined and/or user-selected images, text, and/or video on a rotating display device, including via mapping the image to corresponding mathematical coordinates and toggling illuminating elements to create a POV image, thus reducing or eliminating the issues of modification of the image when displayed;
- c. a high-quality rotational display apparatus in combination with a vehicular wheel to provide ornamental and functional displays;
- d. a rotational display apparatus having the capability of producing a true color images that are substantially equivalent to that of a modern day TV or high-quality computer monitor;
- e. a rotational display apparatus that is capable of displaying both cylindrical and

planar type displays in a single apparatus;

- f. a rotational display apparatus which extends to the illuminating elements to the center of the wheel to allow center-crossing of images;
- g. a rotational display apparatus in combination with a vehicular wheel capable of displaying text and images across a linear bottom line;
- h. a rotational display apparatus in combination with a display device such as a vehicular wheel capable of providing virtual headlight, tail light, brake light, and directional signals;
- i. a panel display device such as a fold out communication device with a rotational scanning display apparatus to provide message communication and image displays;
- j. a panel display device having the capability of producing a true color scanned image;
- k. a panel display device which extends the illuminating elements to allow center-crossing of images;
- l. a display device with a rotational scanning display apparatus to provide message communication and image displays in three dimensions; and
- m. leveraging the capabilities of already-existing devices, including their electrical and/or wireless connection capabilities (including through use of custom hardware and/or software), including by permitting the transfer of data from the user device to the rotational display device, to greatly enhance the functionality of rotational display systems, including because at least the computer and/or controller of the system permits the image information to, *inter alia*, be mapped to relative XY, polar, and/or similar coordinate systems.

See, e.g., Id. at Abstract; 1:36-60; 2:15-28; 2:47-3:67; & 4:18-7:36.

168. The Patented Inventions also provide improved computer, image, and display efficiency at least because they permit the displaying of both cylindrical and planar type displays in a single apparatus and/or showing of pre-defined and/or user-selected images, text, and/or video on a rotating display device (such as a vehicle wheel, rotating toy, helicopter blade, etc.) to display information on a rotating plane of the rotating display device, including via mapping the image to corresponding mathematical coordinates and toggling illuminating elements to create a POV image. *Id.* at Abstract; 1:36-60; 2:15-28; 2:47-3:7; 3:44-67; 4:118-6:15; 6:25-7:36; Claims of the Patents-in-Suit; *see also* Claims of the '813 Patent, '028 Patent, & '389 Patent. The inventor did more than simply apply current technology to an existing problem. The inventions, as embodied in the claims of the Patents-in-Suit, were a significant advancement in rotational display systems. The inventions covered by the claims of the Patents-in-Suit comprise utilization of POV, display, and computer technologies to create a novel architecture for creating and displaying POV images via a rotational display device as described herein – something that, only recently has become more widespread.

169. These noted improvements over the prior art represent meaningful limitations and/or inventive concepts based upon the state of the art nearly two decades ago. Further, including in view of these specific improvements, the claims of the Patents-in-Suit, when such claims are viewed as a whole and in ordered combination, are not routine, well-understood, conventional, generic, existing, commonly used, well known, previously known, typical, and the like nearly two decades ago, including because, until the inventions of the claims of the Patents-in-Suit, the claimed inventions were not existing or even considered in the field, and, in fact, went against the conventional systems and methods.

170. The claims of the Patents-in-Suit, including as a whole, and, where applicable, in ordered combination, comprise, *inter alia*, a non-conventional and non-generic arrangement of

communications between a controller, a computer, a rotatable assembly, an illuminating assembly comprising illuminating elements, and a power delivery means that is a technical improvement to the communications between these devices as operated in a conventional manner, including those improvements noted herein.

171. The claimed inventions are necessarily rooted in computer technology, *i.e.*, image mapping and display technology, and comprise improvements over prior technologies in order to overcome the problems, including those noted herein, specifically arising in the realm of computer-based image mapping and display technologies. The claimed solutions amount to an inventive concept for resolving the particular problems and inefficiencies noted herein, including in connection to the displaying both cylindrical and planar type displays in a single apparatus and/or showing of pre-defined and/or user-selected images, text, and/or video on a rotating display device (such as a vehicle wheel, rotating toy, helicopter blade, etc.) to display information on a rotating plane of the rotating display device, including via mapping the image to corresponding mathematical coordinates and toggling illuminating elements to create a POV image. *Id.* at Abstract; 1:36-60; 2:15-28; 2:47-3:7; 3:44-67; 4:18-6:15; 6:25-7:36; Claims of the Patents-in-Suit; *see also* Claims of the '813 Patent, '028 Patent, & '389 Patent.

3. *The Claims of the Patents-in-Suit do not Unreasonably Preempt their Respective Fields*

172. Plaintiff hereby refers to, and incorporates by reference, the allegations in the above paragraphs as if set forth fully herein.

173. Including as noted herein, neither of the Patents-in-Suit claim merely the abstract idea of “a rotatable display system” that provides no inventive concept. Instead, the '214 Patent claims specific systems for a rotational display system, including a computer for storage and recall of data representing at least one visual image; a controller in wireless/electrical communication with the computer and operable to receive at least some of said data; a rotatable assembly for

displaying an image represented by at least a portion of the data transferred from said computer to the controller; an illuminating assembly operably connected to said controller; at least one illuminating element; a power delivery means for providing power to said rotatable assembly; a support to which the rotatable assembly is constructed and arranged to be attached for rotation about an axis; and an image represented by said data transferred from said computer to the controller displayed by said rotatable assembly during rotation of said rotatable assembly displayed without bending the horizontal ground plane around said axis ('214/Claim 1 & '108/Claim 16; '108/Abstract), where infringement of the claims of each of the Patents-in-Suit can be readily avoided while still practicing any alleged abstract idea, given that the claims of each of the Patents-in-Suit do not purely read on any alleged abstract idea. Indeed, the claims of each of the Patents-in-Suit do not improve color output range, image quality, selectability of displayed images, or image stability of POV devices and systems, as in the prior art, but, instead, improve same by providing a rotational display system for displaying both cylindrical and planar type displays in a single apparatus and/or providing a rotational display system which shows pre-defined and/or user-selected images, text, and/or video on a rotating display device (such as a vehicle wheel, rotating toy, helicopter blade, etc.), including via, *inter alia*, integrating multiple unique lighting technologies (including, *e.g.*, a rotatable assembly comprising at least one lighting assembly), computer systems, controller systems, switching systems, mounting and support systems, information delivery systems, and power supply systems (including, *e.g.*, power supply control mechanism) to display information on a rotating plane of the rotating display device, including as discussed extensively herein. *Id.* at Abstract; 1:36-60; 2:15-28; 2:47-3:7; 3:44-67; 4:18-6:15; 6:25-7:36; Claims of the Patents-in-Suit; *see also* Claims of the '813 Patent, '028 Patent, & '389 Patent.

174. For example, the foregoing may be practiced outside of the limited scope of the

claims of each of the Patents-in-Suit at least by:

- A. The use of a system such as that described in *Matlock* '208, cited by the patent examiner;
- B. The use of a system such as that described in *Hoch*, cited by the patent examiner;
- C. The use of systems such as those described in the specification of '813 Patent;
- D. The use of systems such as those described in the specification of '214 Patent;
- E. The use of systems such as those described in the specification of '108 Patent;
- F. The use of systems such as those described in the specification of '028 Patent; and/or
- G. The use of systems such as those described in the specification of '389 Patent.

COUNT I – INFRINGEMENT OF U.S. PATENT NO. 8,284,214

175. Plaintiff hereby refers to, and incorporates by reference, the allegations in the above paragraphs as if set forth fully herein.

176. Plaintiff is the assignee of the '214 Patent and has all substantial rights, title, and interest thereto, including the right and standing to sue, and recover damages, for past, present, and future infringement thereof, and to collect damages for any such past, present, or future infringement.

177. Claim 1 of the '214 Patent covers a “rotational display system including: a computer for storage and recall of data representing at least one visual image; a controller in wireless communication with the computer and operable to receive at least some of said data; a rotatable assembly for displaying an image represented by at least a portion of the data transferred from said computer to the controller, said rotatable assembly including an illuminating assembly, said illuminating assembly being operably connected to said controller, said illuminating assembly including at least one illuminating element, said rotatable assembly being constructed and arranged for attachment to a support for rotation about an axis; a power delivery means for providing power

to said rotatable assembly; and an image represented by said data transferred from said computer to the controller displayed by said rotatable assembly during rotation of said rotatable assembly, said image displayed without bending the horizontal ground plane around said axis.”

178. Defendant has infringed, is now infringing, and continues to infringe, the '214 Patent, including at least claim 1, in this Judicial District, and elsewhere, in violation of 35 U.S.C. § 271 through actions comprising the making, using, offering for sale, selling, importing, and/or practicing, without authority from Plaintiff, systems for a rotational display system for displaying both cylindrical and planar type displays in a single apparatus and/or providing a rotational display system which shows pre-defined and/or user-selected images, text, and/or video on a rotating display device (such as a vehicle wheel, rotating toy, helicopter blade, etc.), including via, *inter alia*, integrating multiple unique lighting technologies (including, *e.g.*, a rotatable assembly comprising at least one lighting assembly), computer systems, controller systems, switching systems, mounting and support systems, information delivery systems, and power supply systems (including, *e.g.*, power supply control mechanism) to display information on a rotating plane of the rotating display device, including via mapping the image to corresponding mathematical coordinates and toggling illuminating elements to create a POV image, including at least via Defendant's Pixel systems, including as claimed in the '214 asserted claims. On information and belief, Defendant provides the claimed systems with, and via, at least its Poi devices and systems, including at least Defendant's 256 HD, 200 HD, 144 HD, 104 HD, 80 HD, 80 SD, 48 HD, 32 SD, BubblePoi 16 Basic, BubblePoi 16 Smart, BubblePoi 16 Ultimate, Pixel Knob, JellyPoi 24 Basic, JellyPoi 24 Smart, JellyPoi 24 Ultimate, Pixel Stick, Pixel Stick Smart, Juggling Club 72 HD, Juggling Club 48 SD, Juggling Ball, Juggling Ring, Diabolo Sticks 24, Hula Hoop SD, Hula Hoop HD, RG Clubs SD, RG Clubs HD, Buugeng 80, Fans 36, Jump Rope HD, Drumsticks 48, Flying Disc Double 20, Flying Disc 20, Flying Disc 8, and Boomerang 32 HD devices, including at least

in combination with Defendant's other services, devices, and systems, including Defendant's software related thereto, including, without limitation, at least Defendant's Ignis Mobile Application for LED Equipments (including at least the Ignis Mobile Android Application for LED Equipments and/or Ignis Mobile iOS Application for LED Equipments). Further, including at least to the extent Defendant provides and/or supplies hardware, applications, software, and/or services, including applications, software, and/or services running on a user's computer and/or other device, the infringement of users that occurs in connection with Defendant's hardware, applications, software, and/or services occurs under the direction or control of Defendant.

179. Without limitation, and, for example, the infringing instrumentality comprising the Pixel systems comprise a rotational display system including: a computer for storage and recall of data representing at least one visual image; a controller in wireless communication with the computer and operable to receive at least some of said data; a rotatable assembly for displaying an image represented by at least a portion of the data transferred from said computer to the controller, said rotatable assembly including an illuminating assembly, said illuminating assembly being operably connected to said controller, said illuminating assembly including at least one illuminating element, said rotatable assembly being constructed and arranged for attachment to a support for rotation about an axis; a power delivery means for providing power to said rotatable assembly; and an image represented by said data transferred from said computer to the controller displayed by said rotatable assembly during rotation of said rotatable assembly, said image displayed without bending the horizontal ground plane around said axis.

180. Further, the Pixel system comprises systems which comprise a rotational display system, including a rotatable assembly comprising at least one illumination device, a computing device and controller, each comprising wireless communication technology, including Wi-Fi data technologies, which permit communication with the rotatable assembly, including in order for

image data stored on the computer to be transmitted to the rotatable assembly, including via the controller, so that the rotatable assembly can, *inter alia*, power the illumination devices via a power source, rotate about an axis, and display an image transferred to the rotatable assembly while the rotatable assembly is rotated about the axis, including without bending the horizontal ground plane relative to the image and/or without otherwise warping and/or distorting the image.

181. For example, including as exemplified by Defendant's Poi devices, the Pixel system permits, *inter alia*, a rotational display system for displaying both cylindrical and planar type displays in a single apparatus and/or a pre-defined and/or user-selected images, text, and/or video on a rotating display device (such as a vehicle wheel, rotating toy, helicopter blade, etc.), including via, *inter alia*, integrating multiple unique lighting technologies (including, *e.g.*, a rotatable assembly comprising at least one lighting assembly), computer systems, controller systems, switching systems, mounting and support systems, information delivery systems, and power supply systems (including, *e.g.*, power supply control mechanism) to display information on a rotating plane of the rotating display device, including via mapping the image to corresponding mathematical coordinates and toggling illuminating elements to create a POV image:

Programming timeline modes (time-programmed sequence of pictures).

You can set the duration for each uploaded picture, thus creating a sequence of them, synchronized with the music. There are ten timeline custom sequences, T1-T10.

To configure the timeline:

1. Run Ignis Pixel Utility;
2. Open single pictures from files through menu **Add -> Image** or drag and drop files to the Image list into the left upper area of Ignis Pixel Utility;
3. Select images in Image list, drag and drop them to a timeline (T1-T10) to the lower area of Ignis Pixel Utility;
4. Now you see a sequence of pictures. You can change their order and duration by dragging them or their borders, like in video editors. Use Ctrl (Cmd for MacOS) button to change editing method Ripple edit/Rolling edit;
5. To adjust the timeline synchronously with music, add your music file through menu **Add -> Music** or drag and drop an MP3 file to the Music slot of Ignis Pixel Utility (lower area, just above the timelines);
6. Connect your digital poi to your computer with Micro-USB cables and press **Scan** button in the **Device list** (right area of Ignis Pixel Utility);
7. Click "**Upload all**" button – the process can take up to several minutes depending on the poi model and height-width ratios of the pictures.
8. When you change only a duration or an order of pictures in a timeline to save time, just tick the required timeline and click "**Upload Checked**" – the process will take just a few seconds.

Saving your project

The software allows you to save the project, and you can send your project by e-mail or USB flash to another computer. You do not need to send the original pictures of your project. They are contained within the project file.

See, e.g., Manual for Ignis Pixel Poi at page 4, located at https://ignispixel.com/files/upload/manual/Manual_Ignis_Pixel_v3_EN.pdf

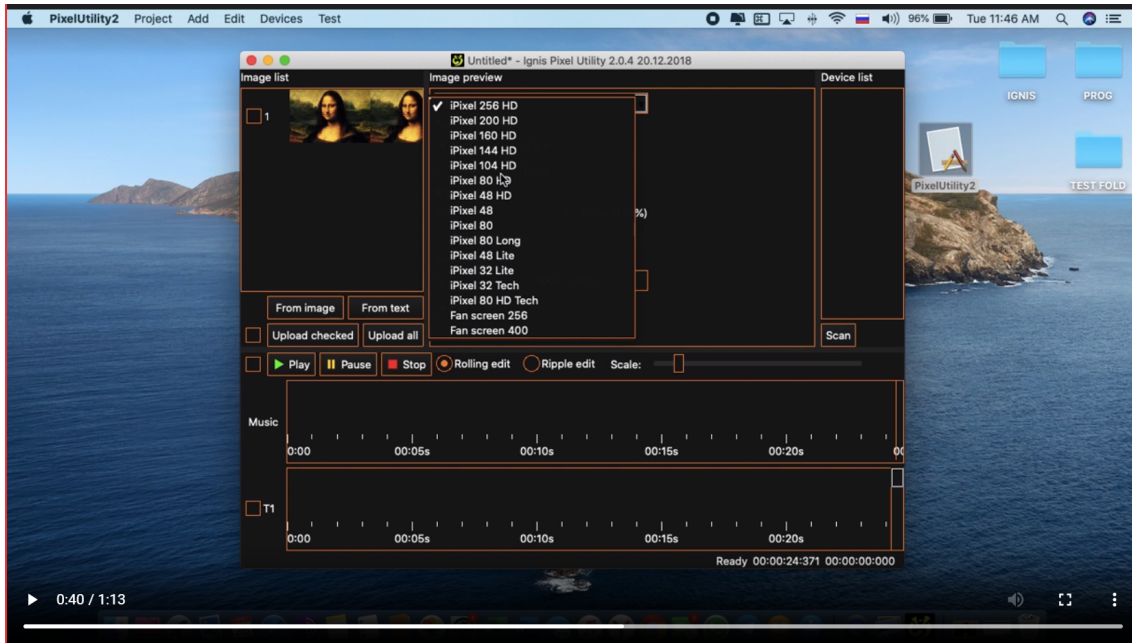

See, e.g., Installation Instructions for Ignis Pixel Utility 2 Application at timestamp 0:40, located at <https://ipxl.nyc3.cdn.digitaloceanspaces.com/videos/ignis-utility-macos-install-720p.mp4>

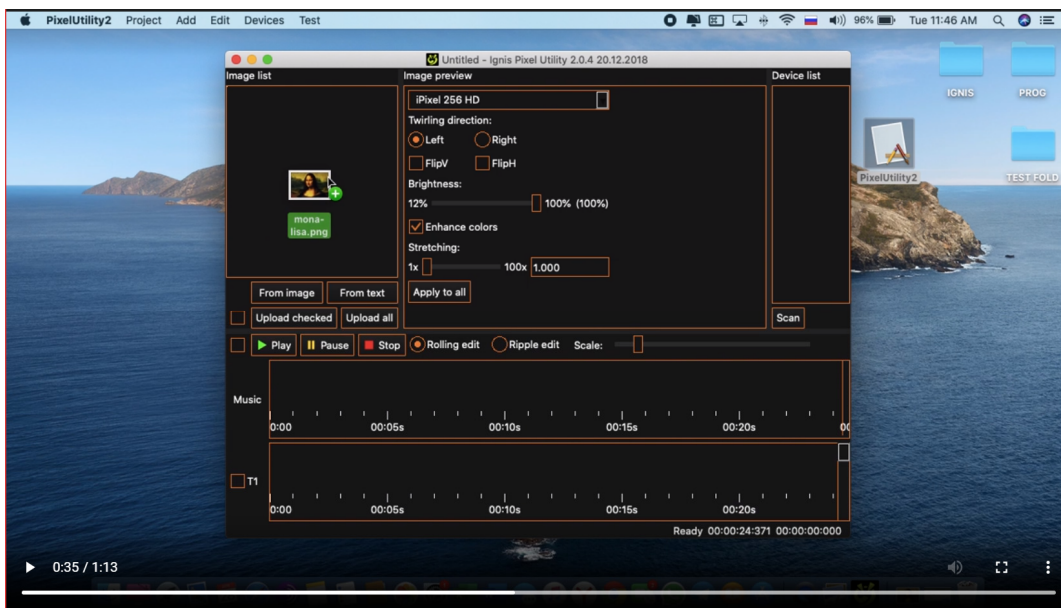

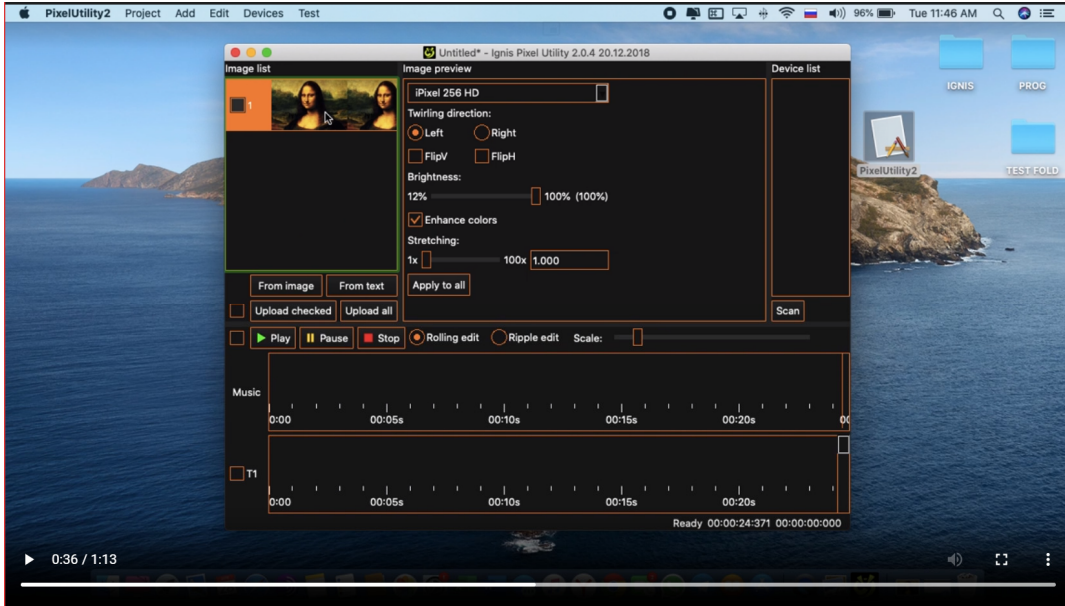

See, e.g., Installation Instructions for Ignis Pixel Utility 2 Application at timestamp 0:35-0:36, located at <https://ipxl.nyc3.cdn.digitaloceanspaces.com/videos/ignis-utility-macos-install-720p.mp4>

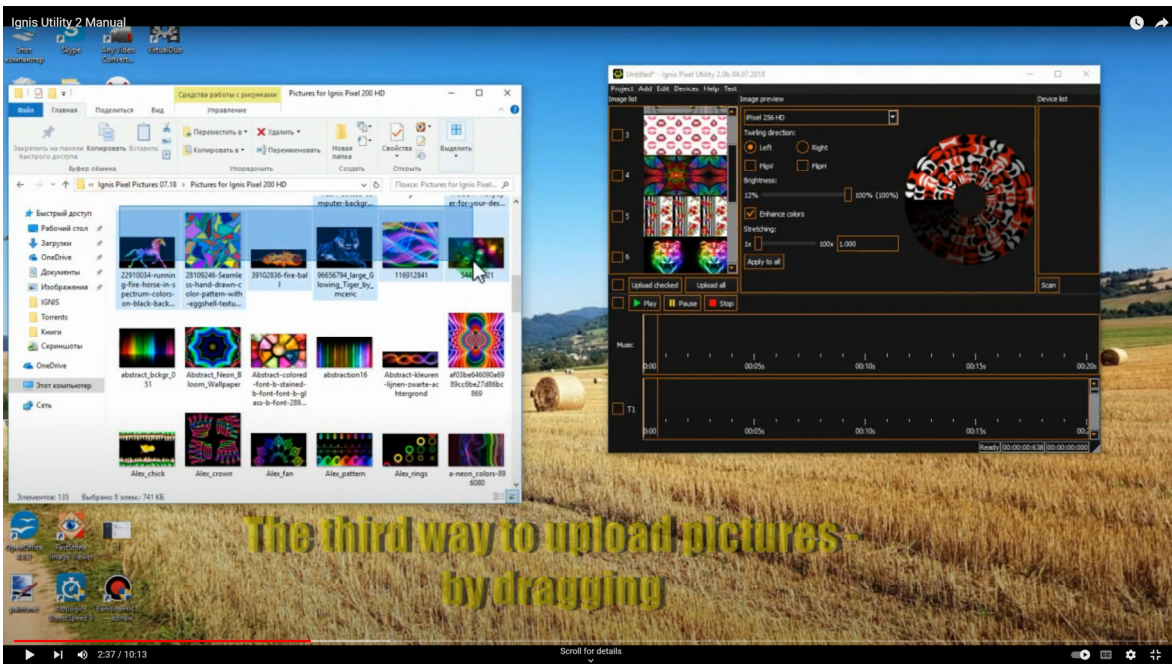

See, e.g., YouTube video by Igor Ignis titled “Ignis Utility 2 Manual” at timestamp 2:36-2:38, located at <https://www.youtube.com/watch?v=FUdYDPsoVnQ>



See, e.g., Ignis Downloads page, located at <https://ignispixel.com/downloads#app>

Bluetooth connection to a cellphone

Install Ignis Pixel App on your cell phone to get access to get full functions of Ignis product. Turn on Bluetooth on your phone to connect the device. Ignis mobile app allows to operate the device via your cellphone (to upload pictures, make timelines, launch and stop the device, change brightness of pictures and duration). If you have Smart or Ultimate versions, you can see detailed statistics in the app. You can operate more than one device synchronously. The app is available for both Android and iPhone versions.

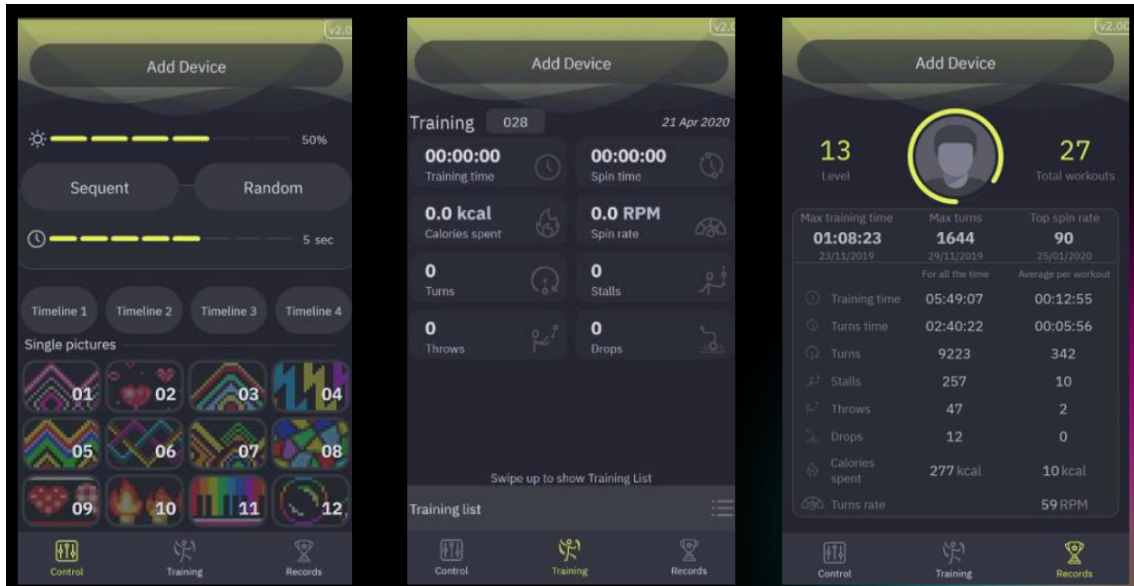

See, e.g., Manual for BubblePoi, JellyPoi 16/24 at page 10, located at https://assets.ipxl.ru/storage/product_file/a840f0829c769d4d707956f5ef77e4e1.pdf

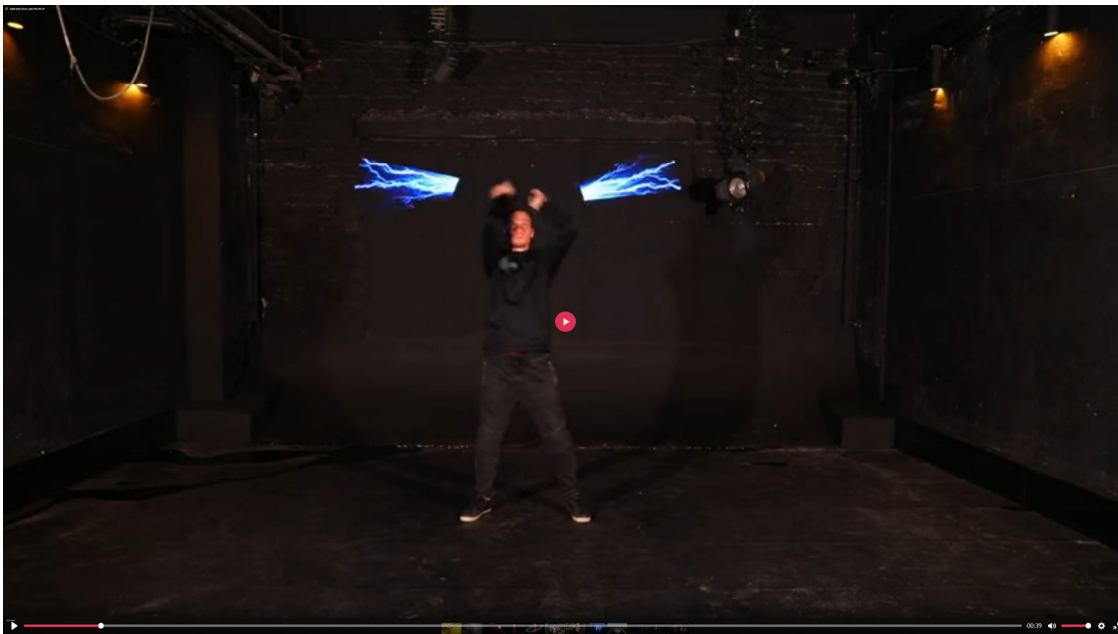

See, e.g., Ignis 256 HD product page, located at <https://ignispixel.com/product/ignis-pixel-poi-256-hd>

182. The Pixel system comprises a computer. For example, the Pixel system includes at least an attached and/or connected computing device (e.g., a laptop, desktop, mobile phone, tablet, etc.) or another Poi Device:

Programming timeline modes (time-programmed sequence of pictures).

You can set the duration for each uploaded picture, thus creating a sequence of them, synchronized with the music. There are ten timeline custom sequences, T1-T10.

To configure the timeline:

1. Run Ignis Pixel Utility;
2. Open single pictures from files through menu **Add -> Image** or drag and drop files to the Image list into the left upper area of Ignis Pixel Utility;
3. Select images in Image list, drag and drop them to a timeline (T1-T10) to the lower area of Ignis Pixel Utility;
4. Now you see a sequence of pictures. You can change their order and duration by dragging them or their borders, like in video editors. Use Ctrl (Cmd for MacOS) button to change editing method Ripple edit/Rolling edit;
5. To adjust the timeline synchronously with music, add your music file through menu **Add -> Music** or drag and drop an MP3 file to the Music slot of Ignis Pixel Utility (lower area, just above the timelines);
6. Connect your digital poi to your computer with Micro-USB cables and press **Scan** button in the **Device list** (right area of Ignis Pixel Utility);
7. Click **"Upload all"** button – the process can take up to several minutes depending on the poi model and height-width ratios of the pictures.
8. When you change only a duration or an order of pictures in a timeline to save time, just tick the required timeline and click **"Upload Checked"** – the process will take just a few seconds.

Saving your project

The software allows you to save the project, and you can send your project by e-mail or USB flash to another computer. You do not need to send the original pictures of your project. They are contained within the project file.

See, e.g., Manual for Ignis Pixel Poi at page 4, located at https://ignispixel.com/files/upload/manual/Manual_Ignis_Pixel_v3_EN.pdf

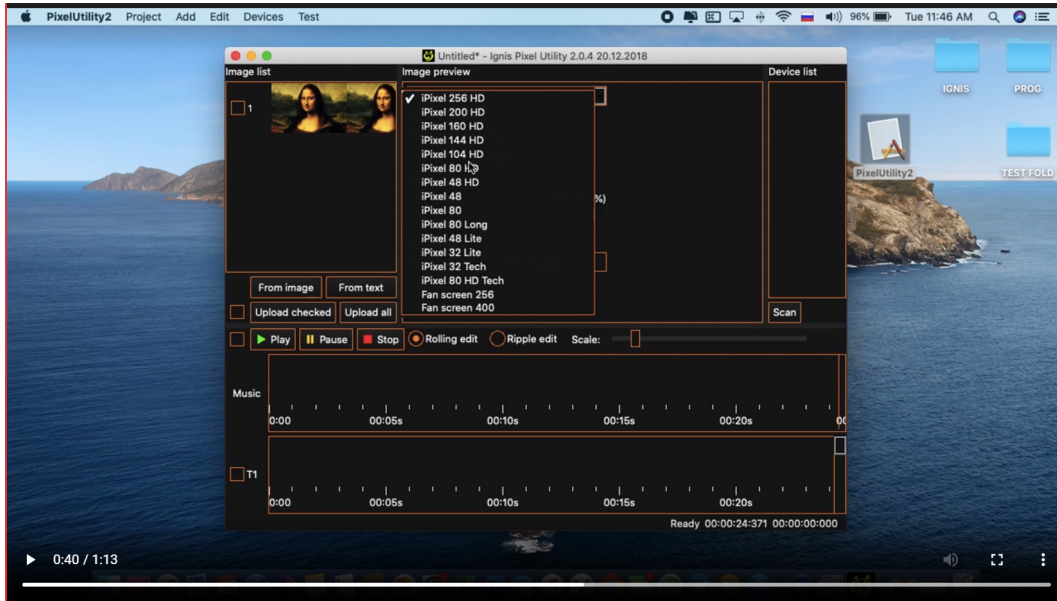

See, e.g., Installation Instructions for Ignis Pixel Utility 2 Application at timestamp 0:40, located at <https://ipxl.nyc3.cdn.digitaloceanspaces.com/videos/ignis-utility-macos-install-720p.mp4>

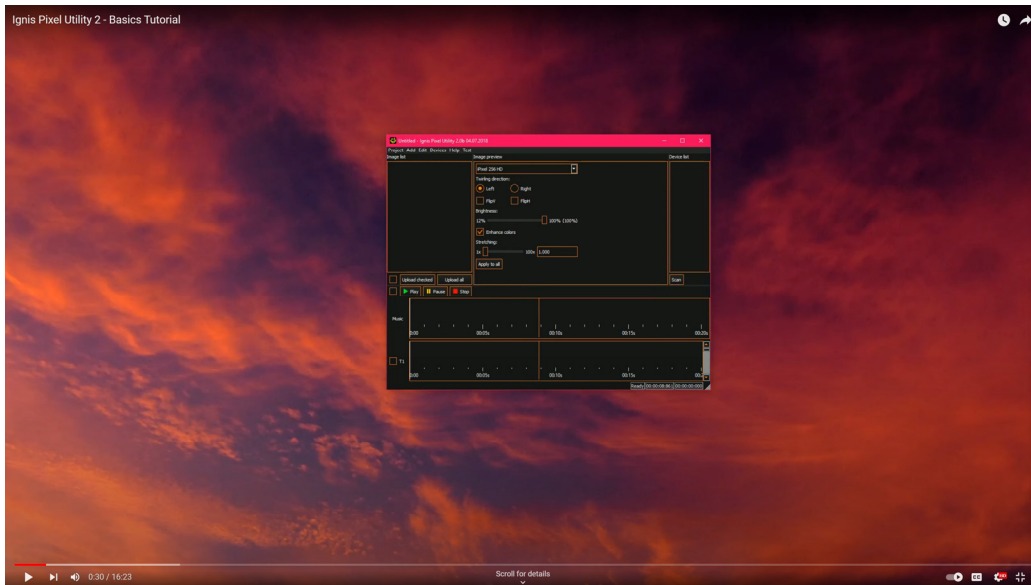

See, e.g., YouTube video by Devmode titled “Ignis Pixel Utility 2 – Basic Tutorial” at timestamp 0:30, located at <https://www.youtube.com/watch?v=xFFPDyKbD4Y>

183. The Pixel system comprises the computer being for storage of data representing at least one visual image. For example, the Pixel system includes at least a computing device having Defendant’s software installed thereon, permitting the user to, *inter alia*, store images as picture or other data files, including images for use with an Ignis Poi Device:

Programming timeline modes (time-programmed sequence of pictures).

You can set the duration for each uploaded picture, thus creating a sequence of them, synchronized with the music. There are ten timeline custom sequences, T1-T10.

To configure the timeline:

1. Run Ignis Pixel Utility;
2. Open single pictures from files through menu **Add -> Image** or drag and drop files to the Image list into the left upper area of Ignis Pixel Utility;
3. Select images in Image list, drag and drop them to a timeline (T1-T10) to the lower area of Ignis Pixel Utility;
4. Now you see a sequence of pictures. You can change their order and duration by dragging them or their borders, like in video editors. Use Ctrl (Cmd for MacOS) button to change editing method Ripple edit/Rolling edit;
5. To adjust the timeline synchronously with music, add your music file through menu **Add -> Music** or drag and drop an MP3 file to the Music slot of Ignis Pixel Utility (lower area, just above the timelines);
6. Connect your digital poi to your computer with Micro-USB cables and press **Scan** button in the **Device list** (right area of Ignis Pixel Utility);
7. Click "**Upload all**" button – the process can take up to several minutes depending on the poi model and height-width ratios of the pictures.
8. When you change only a duration or an order of pictures in a timeline to save time, just tick the required timeline and click "**Upload Checked**" – the process will take just a few seconds.

See, e.g., Manual for Ignis Pixel Poi at page 4, located at https://ignispixel.com/files/upload/manual/Manual_Ignis_Pixel_v3_EN.pdf

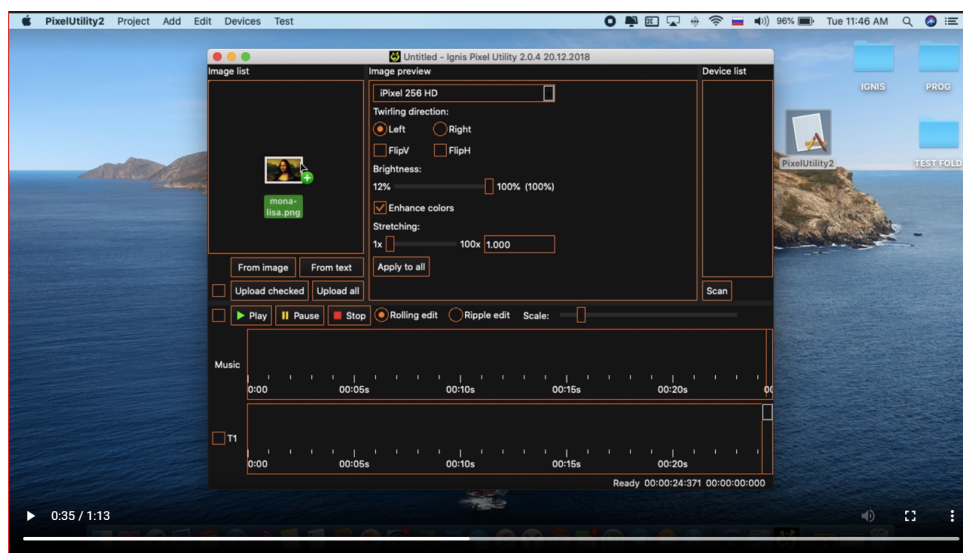

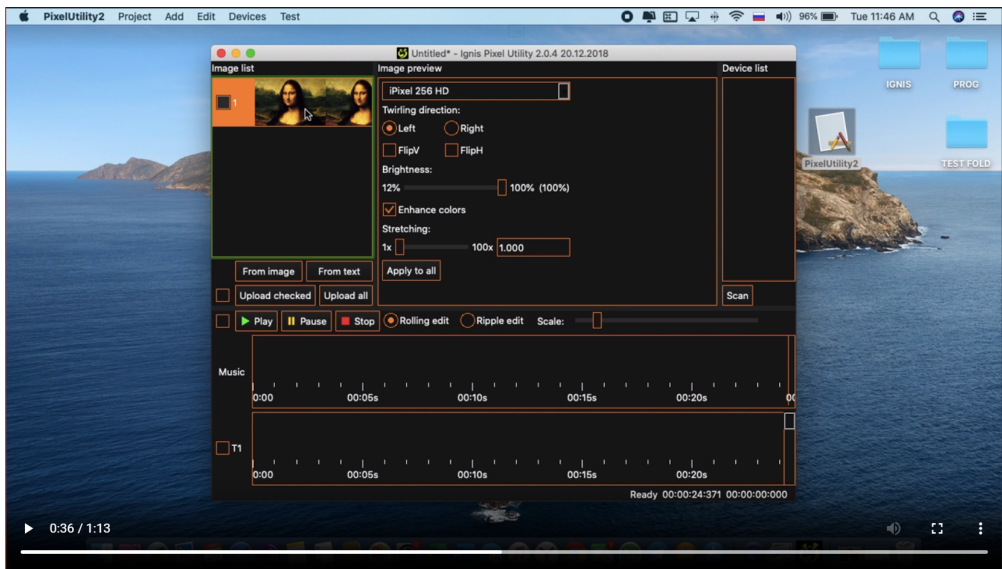

See, e.g., Installation Instructions for Ignis Pixel Utility 2 Application at timestamp 0:35-0:36, located at <https://ipxl.nyc3.cdn.digitaloceanspaces.com/videos/ignis-utility-macos-install-720p.mp4>

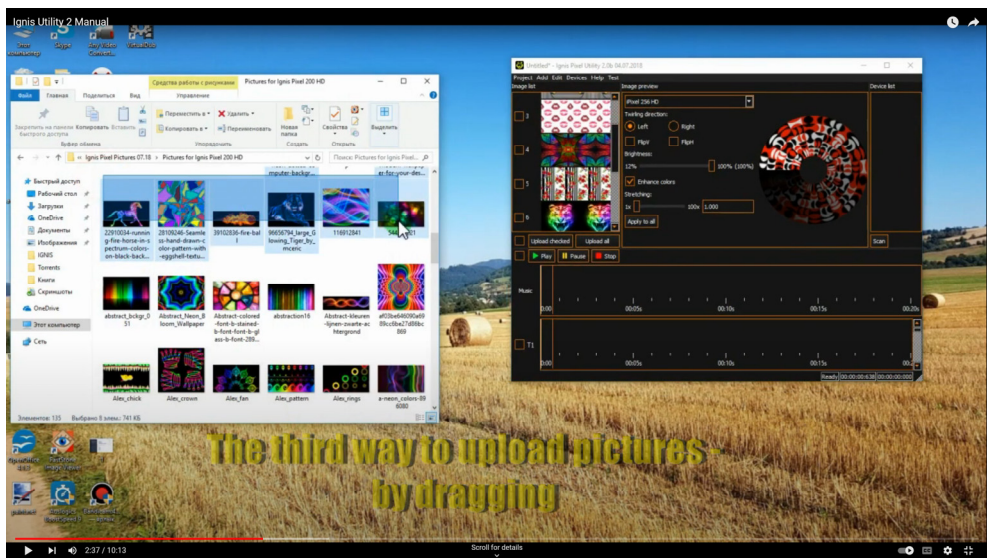

See, e.g., YouTube video by Igor Ignis titled “Ignis Utility 2 Manual” at timestamp 2:36-2:38, located at <https://www.youtube.com/watch?v=FUDYDPsoVnQ>

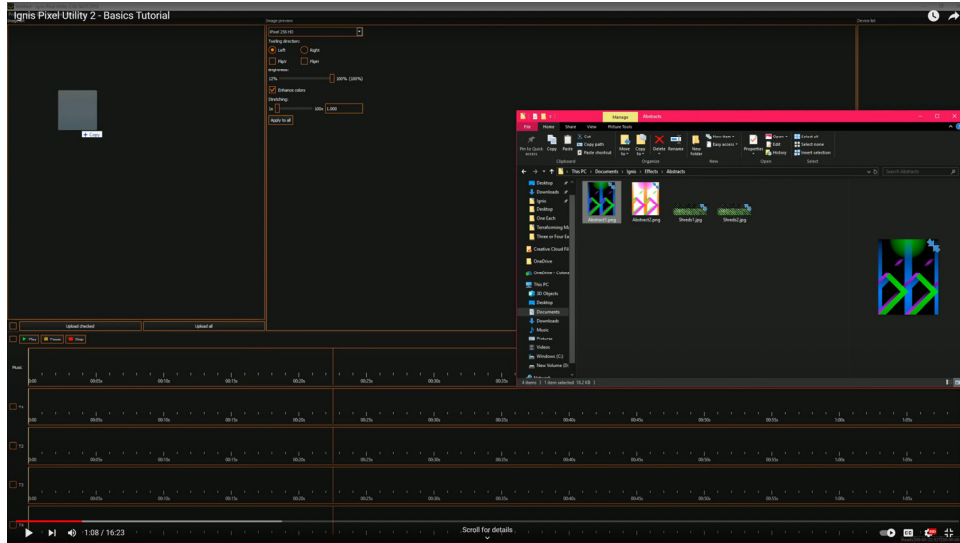

See, e.g., YouTube video by Devmode titled “Ignis Pixel Utility 2 – Basic Tutorial” at timestamp 1:08-1:10, located at <https://www.youtube.com/watch?v=xFFPDyKbD4Y>

184. The Pixel system comprises the computer being for recall of data representing at least one visual image. For example, the Pixel system includes at least a computing device having Defendant’s software installed thereon, permitting the user to, *inter alia*, retrieve and view images stored as picture or other data files, including images for use with an Ignis Poi Device:

Programming timeline modes (time-programmed sequence of pictures).

You can set the duration for each uploaded picture, thus creating a sequence of them, synchronized with the music. There are ten timeline custom sequences, T1-T10.

To configure the timeline:

1. Run Ignis Pixel Utility;
2. Open single pictures from files through menu **Add -> Image** or drag and drop files to the Image list into the left upper area of Ignis Pixel Utility;
3. Select images in Image list, drag and drop them to a timeline (T1-T10) to the lower area of Ignis Pixel Utility;
4. Now you see a sequence of pictures. You can change their order and duration by dragging them or their borders, like in video editors. Use Ctrl (Cmd for MacOS) button to change editing method Ripple edit/Rolling edit;
5. To adjust the timeline synchronously with music, add your music file through menu **Add -> Music** or drag and drop an MP3 file to the Music slot of Ignis Pixel Utility (lower area, just above the timelines);
6. Connect your digital poi to your computer with Micro-USB cables and press **Scan** button in the **Device list** (right area of Ignis Pixel Utility);
7. Click "**Upload all**" button – the process can take up to several minutes depending on the poi model and height-width ratios of the pictures.
8. When you change only a duration or an order of pictures in a timeline to save time, just tick the required timeline and click "**Upload Checked**" – the process will take just a few seconds.

See, e.g., Manual for Ignis Pixel Poi at page 4, located at https://ignispixel.com/files/upload/manual/Manual_Ignis_Pixel_v3_EN.pdf

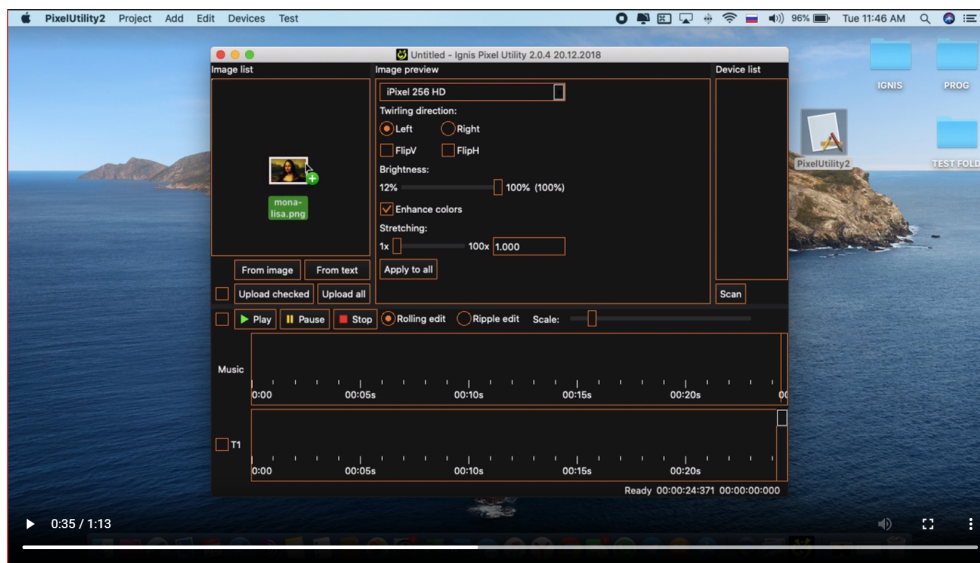

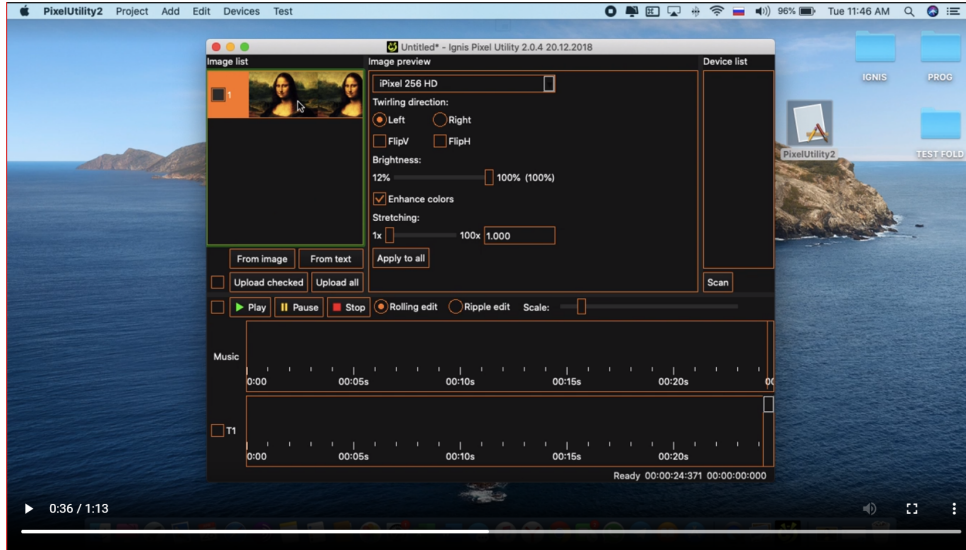

See, e.g., Installation Instructions for Ignis Pixel Utility 2 Application at timestamp 0:35-0:36, located at <https://ipxl.nyc3.cdn.digitaloceanspaces.com/videos/ignis-utility-macos-install-720p.mp4>

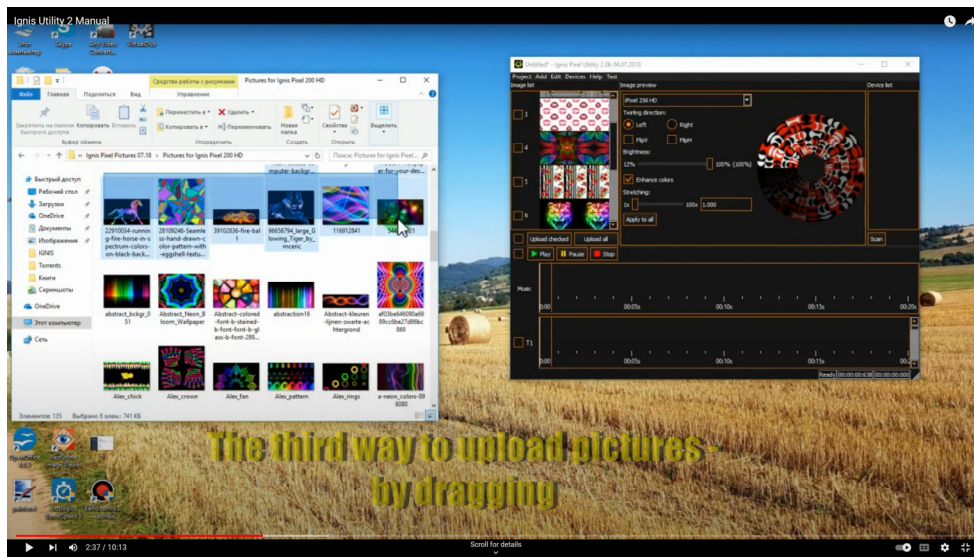

See, e.g., YouTube video by Igor Ignis titled “Ignis Utility 2 Manual” at timestamp 2:36-2:38, located at <https://www.youtube.com/watch?v=FUDYDPsoVnQ>

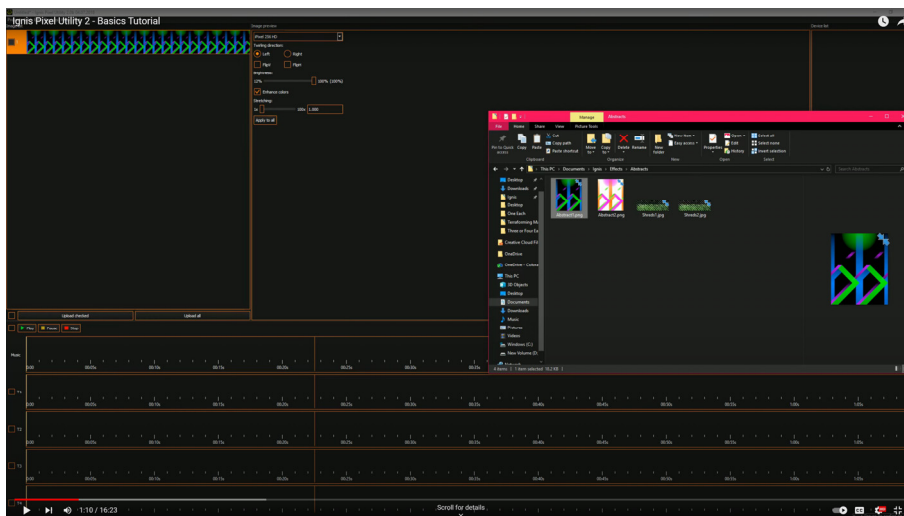
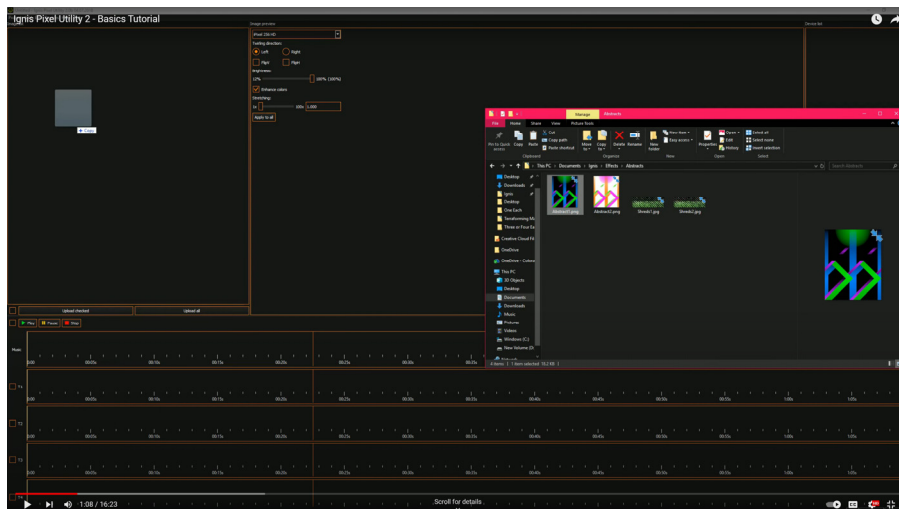

See, e.g., YouTube video by Devmode titled “Ignis Pixel Utility 2 – Basic Tutorial” at timestamp 1:08-1:10, located at <https://www.youtube.com/watch?v=xFFPDyKbD4Y>

185. The Pixel system comprises a controller in wireless communication with the computer. For example, the Pixel system includes at least hardware, software, and/or firmware, including, *inter alia*, circuitry and/or sensor devices, within the Poi device comprising wireless connectivity (e.g., Wi-Fi, Bluetooth, etc.) permitting the Pixel system to, *inter alia*, connect to, and communicate with, the user’s computing device over said wireless connectivity protocol:



See, e.g., Ignis Downloads page, located at <https://ignispixel.com/downloads#app>

Upload your pictures, texts, emoji, logos, patterns and effects - directly from Mobile App from your phone! Programming is carried out in Ignis Pixel application on your mobile phone. This also makes your phone a remote controller for your JellyPoi: launch them and switch pictures at a distance right from phone. (available for Android and iOS).

Now your phone turns into remote controller for JellyPoi 24. While you spin your friend can change pictures according to the music.

See, e.g., Ignis JellyPoi 24 product page, located at <https://ignispixel.com/product/ignis-pixel-jellypoi-24-basic>

Upload your pictures, texts, emoji, logos, patterns and effects - directly from Mobile App on your phone! Programming is carried out in Ignis Pixel application on your mobile phone. This also makes your phone a remote controller for your JellyPoi: launch them and switch pictures at a distance right from phone (available for Android and iOS).

See, e.g., Ignis JellyPoi 24 & Pixel Knobs product page, located at <https://ignispixel.com/product/ignis-pixel-jellypoi-24-with-knob>

Upload your own pictures, texts, emoji, logos, patterns and effects - directly from Mobile App on your phone. This also makes your phone a remote controller for your Ignis Sticks: launch them and switch pictures at a distance right from the phone (available for Android and iOS). While you are spinning, your friend can change patterns according to the music. Moreover, it is possible to use a fully pre-programmed timeline.

See, e.g., Ignis Stick 20 product page, located at <https://ignispixel.com/product/ignis-pixel-stick>

Programming is carried out in Ignis Pixel application on your mobile phone. This also makes your phone a remote controller for your BubblePoi: launch them and switch pictures at a distance right from phone.

See, e.g., Ignis BubblePoi 16 product page, located at <https://ignispixel.com/product/bubble-led-poi-16-48-leds-basic>

Upload texts, emoji, logos and simple graphic! Relatively low resolution is offset by the brightness — Ignis Pixel 32 Tech are noticeable at night, lamplight and even in daylight. These affordable pixel LED pois are fully programmable and have all main functions of professional sets that can help to make your show spectacular and impressive. You can synchronize your performance scenario with music and adjust up to 10 timelines in the convenient software for Windows and MacOS. Start your career with these simple poi sticks and come back for some advanced models in future.

The poi 32 SD are equipped with Wireless Sync option that allows synchronizing the poi between each other and with other Ignis props. A perfect solution with many settings of group work to ensure sync work of props in big teams.

See, e.g., Ignis 32 SD product page, located at <https://ignispixel.com/product/ignis-pixel-poi-32-tech>

These pixel LED pois are fully programmable and have all main functions of more expensive professional sets. Upload texts, emoji, logos and graphic, synchronize your performance scenario with music, and adjust up to 10 timelines in the convenient software for Windows and MacOS. Ignis Pixel 48 Lite work up to 4 hours — this is quite enough to show the audience your skills and artistry.

The poi 48 HD are equipped with Wireless Sync option that allows synchronizing the poi between each other and with other Ignis props. A perfect solution with many settings of group work to ensure sync work of props in big teams.

See, e.g., Ignis 48 SD product page, located at <https://ignispixel.com/product/ignis-pixel-poi-48-lite>

Resolution of 80 pixels allows to upload not only text, emoji, logos, and graphic, but also photos of people's faces. This will help to make your shows more custom and various. Ignis 80 Long also supports music synchronization and with the help of our software for Windows and MacOS you can adjust up to 10 timelines. As you can see, this LED poi set is just as good as PRO models.

The poi 80 SD are equipped with Wireless Sync option that allows synchronizing the poi between each other and with other Ignis props. A perfect solution with many settings of group work to ensure sync work of props in big teams.

See, e.g., Ignis 80 SD product page, located at <https://ignispixel.com/product/ignis-pixel-poi-80>

Ignis 80 HD Tech is our flagship model for professional spinners. Ignis 80 HD Tech has the best balance between length, number of LEDs, and resolution on the market of pixel equipment. At first we made this model for such profiles as Tim Goddard (@timmehtek) from Australia, Yuta Imamura (@yutapoi) from Japan, Ben Drexler (@drexfactor) from the USA, Gustavo Ollitta (@gollitta) from Brazil, but decided that Ignis 80 HD Tech deserves attention of other professionals. Short length (6.7 inch) allows to do spirals, wraps, orbitals, hyperloops and even juggling them. And due to the high resolution of 80 pixels, you can upload to this LED poi set texts, emoji, logos, graphic and also photos with people's faces and small details. Work with programmable LED poi sticks in the user-friendly software compatible with Windows and Mac OS. If our world record in resolution doesn't make sense to you, then pay attention to the rendering speed — 3 000 rows per second!

To make technically advanced tricks such as hyperloops we supplied 80 HD Tech with bearing swivels. We also made them light (4.2 oz) and added all functions that could be useful for professionals: music synchronization, ability to adjust up to 10 timelines and wireless control option (not included in standard digital poi set).

The poi 80 HD are equipped with Wireless Sync option that allows synchronizing the poi between each other and with other Ignis props. A perfect solution with many settings of group work to ensure sync work of props in big teams.

See, e.g., Ignis 80 HD product page, located at <https://ignispixel.com/product/ignis-pixel-poi-80-hd-tech>

LED poi Ignis 104 HD is shortest digital poi with high 104-pixel resolution. Length of poi is only 35 cm, which is suitable for performing technically advanced spinning with elements such as spirals, wraps and even orbitals. 104 LEDs mounted with pitch 2.1 mm to each other and allows you to draw in the air not only pictures but also photos with faces of people who are easily recognized by the audience!

No doubt with Ignis 104 HD your performance makes a sensation!

The poi are equipped with the following built-in features:

— Wireless Sync option – allows synchronizing the poi between each other and with other Ignis props. A perfect solution with many settings of group work to ensure sync work of props in big teams;

See, e.g., Ignis 104 HD product page, located at <https://ignispixel.com/product/ignis-pixel-poi-104-hd>

Ignis 144 HD are fully programmable poi. They have everything you need — music synchronisation, ability to adjust up to 10 timelines using software for Windows and MacOS, and wireless control option (not included in standard digital poi set).

The poi are equipped with the following built-in features:

— Wireless Sync option – allows synchronizing the poi between each other and with other Ignis props. A perfect solution with many settings of group work to ensure sync work of props in big teams;

See, e.g., Ignis 144 HD product page, located at <https://ignispixel.com/product/ignis-pixel-poi-144-hd>

This is the favorite model of Ignis Pixel CEO Grigoriy Zhuravlev and artists from big shows, such as Circus of Zapashny brothers and Cirque du Soleil. Ignis 200 HD are also suitable for ladies and people with relatively short height — the total length of this model is 21.7 inch. The resolution of 200 pixels coupled with high rendering speed (2600 rows per second) allows to upload text, logos, emoji, graphic and detailed photos.

We also changed LEDs in new generation of Ignis Pixel 200 HD. New tiny LEDs show perfect colors with improved yellow and orange tones, that makes pictures on pois sharper, more realistic, and colorful. Synchronize your shows with music, adjust up to 10 timelines and make more money with our pixel equipment.

The poi are equipped with the following built-in features:

— Wireless Sync option – allows synchronizing the poi between each other and with other Ignis props. A perfect solution with many settings of group work to ensure sync work of props in big teams;

See, e.g., Ignis 200 HD product page, located at <https://ignispixel.com/product/ignis-pixel-poi-200-hd>

Upload logos, text, emoji, graphic, photos and don't bother — they will be recognisable at and in partial blackout. Synchronise your shows with music, adjust up to 10 timelines in our user-friendly software for Windows and Mac OS and make more money on your shows. We are sure, that these investments will pay off.

The poi are equipped with the following built-in features:

— Wireless Sync option – allows synchronizing the poi between each other and with other Ignis props. A perfect solution with many settings of group work to ensure sync work of props in big teams;

See, e.g., Ignis 256 HD product page, located at <https://ignispixel.com/product/ignis-pixel-poi-256-hd>

—● **Bluetooth connection to a cellphone**

Install Ignis Pixel App on your cell phone to get access to get full functions of Ignis product. Turn on Bluetooth on your phone to connect the device. Ignis mobile app allows to operate the device via your cellphone (to upload pictures, make timelines, launch and stop the device, change brightness of pictures and duration). If you have Smart or Ultimate versions, you can see detailed statistics in the app. You can operate more than one device synchronously. The app is available for both Android and iPhone versions.

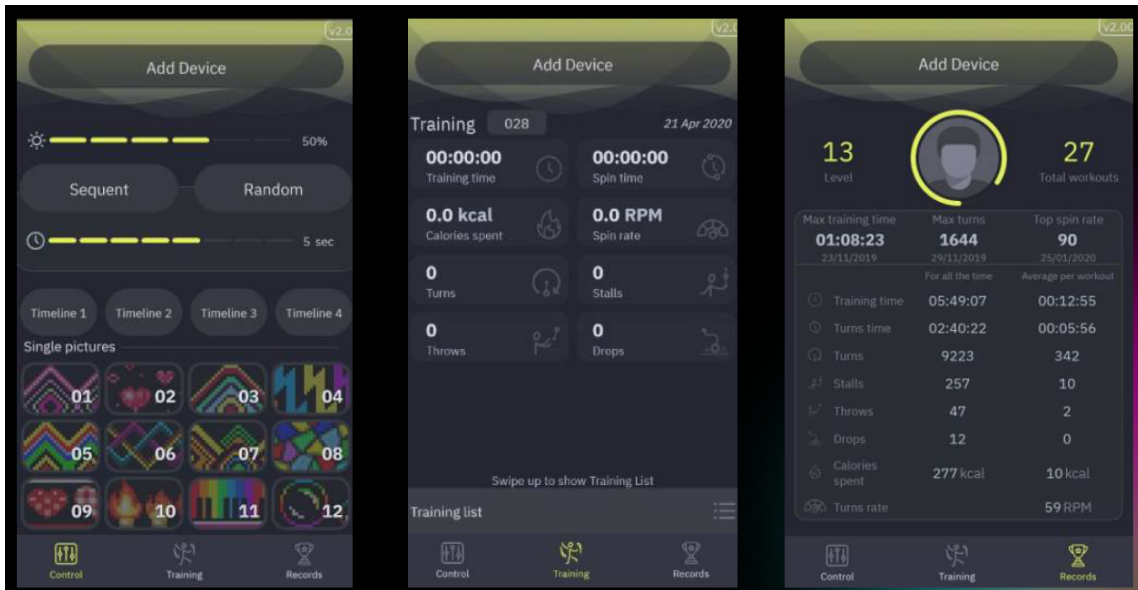

See, e.g., Manual for BubblePoi, JellyPoi 16/24 at page 10, located at https://assets.ipxl.ru/storage/product_file/a840f0829c769d4d707956f5ef77e4e1.pdf

186. The Pixel system comprises the controller being operable to receive at least some of said data. For example, the Pixel system includes at least the controller, via the connection to the computer, receiving the images, and corresponding data, chosen by the user for display, including via the use of Defendant's software:



See, e.g., Ignis Downloads page, located at <https://ignispixel.com/downloads#app>

Upload your pictures, texts, emoji, logos, patterns and effects - directly from Mobile App from your phone! Programming is carried out in Ignis Pixel application on your mobile phone. This also makes your phone a remote controller for your JellyPoi: launch them and switch pictures at a distance right from phone. (available for Android and iOS).

Now your phone turns into remote controller for JellyPoi 24. While you spin your friend can change pictures according to the music.

See, e.g., Ignis JellyPoi 24 product page, located at <https://ignispixel.com/product/ignis-pixel-jellypoi-24-basic>

Upload your pictures, texts, emoji, logos, patterns and effects - directly from Mobile App from your phone! Programming is carried out in Ignis Pixel application on your mobile phone. This also makes your phone a remote controller for your JellyPoi: launch them and switch pictures at a distance right from phone (available for Android and iOS).

See, e.g., Ignis JellyPoi 24 & Pixel Knobs product page, located at <https://ignispixel.com/product/ignis-pixel-jellypoi-24-with-knob>

Upload your own pictures, texts, emoji, logos, patterns and effects - directly from Mobile App on your phone. This also makes your phone a remote controller for your Ignis Sticks: launch them and switch pictures at a distance right from the phone (available for Android and iOS). While you are spinning, your friend can change patterns according to the music. Moreover, it is possible to use a fully pre-programmed timeline.

See, e.g., Ignis Stick 20 product page, located at <https://ignispixel.com/product/ignis-pixel-stick>

Programming is carried out in Ignis Pixel application on your mobile phone. This also makes your phone a remote controller for your BubblePoi: launch them and switch pictures at a distance right from phone.

See, e.g., Ignis BubblePoi 16 product page, located at <https://ignispixel.com/product/bubble-led-poi-16-48-leds-basic>

Upload texts, emoji, logos and simple graphic! Relatively low resolution is offset by the brightness — Ignis Pixel 32 Tech are noticeable at night, lamplight and even in daylight. These affordable pixel LED pois are fully programmable and have all main functions of professional sets that can help to make your show spectacular and impressive. You can synchronize your performance scenario with music and adjust up to 10 timelines in the convenient software for Windows and MacOS. Start your career with these simple poi sticks and come back for some advanced models in future.

The poi 32 SD are equipped with Wireless Sync option that allows synchronizing the poi between each other and with other Ignis props. A perfect solution with many settings of group work to ensure sync work of props in big teams.

See, e.g., Ignis 32 SD product page, located at <https://ignispixel.com/product/ignis-pixel-poi-32-tech>

These pixel LED pois are fully programmable and have all main functions of more expensive professional sets. Upload texts, emoji, logos and graphic, synchronize your performance scenario with music, and adjust up to 10 timelines in the convenient software for Windows and MacOS. Ignis Pixel 48 Lite work up to 4 hours — this is quite enough to show the audience your skills and artistry.

The poi 48 HD are equipped with Wireless Sync option that allows synchronizing the poi between each other and with other Ignis props. A perfect solution with many settings of group work to ensure sync work of props in big teams.

See, e.g., Ignis 48 SD product page, located at <https://ignispixel.com/product/ignis-pixel-poi-48-lite>

Resolution of 80 pixels allows to upload not only text, emoji, logos, and graphic, but also photos of people's faces. This will help to make your shows more custom and various. Ignis 80 Long also supports music synchronization and with the help of our software for Windows and MacOS you can adjust up to 10 timelines. As you can see, this LED poi set is just as good as PRO models.

The poi 80 SD are equipped with Wireless Sync option that allows synchronizing the poi between each other and with other Ignis props. A perfect solution with many settings of group work to ensure sync work of props in big teams.

See, e.g., Ignis 80 SD product page, located at <https://ignispixel.com/product/ignis-pixel-poi-80>

Ignis 80 HD Tech is our flagship model for professional spinners. Ignis 80 HD Tech has the best balance between length, number of LEDs, and resolution on the market of pixel equipment. At first we made this model for such profiles as Tim Goddard (@timmehtek) from Australia, Yuta Imamura (@yutapoi) from Japan, Ben Drexler (@drexfactor) from the USA, Gustavo Ollitta (@gollitta) from Brazil, but decided that Ignis 80 HD Tech deserves attention of other professionals. Short length (6.7 inch) allows to do spirals, wraps, orbitals, hyperloops and even juggling them. And due to the high resolution of 80 pixels, you can upload to this LED poi set texts, emoji, logos, graphic and also photos with people's faces and small details. Work with programmable LED poi sticks in the user-friendly software compatible with Windows and Mac OS. If our world record in resolution doesn't make sense to you, than pay attention to the rendering speed — 3 000 rows per second!

To make technically advanced tricks such as hyperloops we supplied 80 HD Tech with bearing swivels. We also made them light (4.2 oz) and added all functions that could be useful for professionals: music synchronization, ability to adjust up to 10 timelines and wireless control option (not included in standard digital poi set).

The poi 80 HD are equipped with Wireless Sync option that allows synchronizing the poi between each other and with other Ignis props. A perfect solution with many settings of group work to ensure sync work of props in big teams.

See, e.g., Ignis 80 HD product page, located at <https://ignispixel.com/product/ignis-pixel-poi-80-hd-tech>

LED poi Ignis 104 HD is shortest digital poi with high 104-pixel resolution. Length of poi is only 35 cm, which is suitable for performing technically advanced spinning with elements such as spirals, wraps and even orbitals. 104 LEDs mounted with pitch 2.1 mm to each other and allows you to draw in the air not only pictures but also photos with faces of people who are easily recognized by the audience!

No doubt with Ignis 104 HD your performance makes a sensation!

The poi are equipped with the following built-in features:

— Wireless Sync option – allows synchronizing the poi between each other and with other Ignis props. A perfect solution with many settings of group work to ensure sync work of props in big teams;

See, e.g., Ignis 104 HD product page, located at <https://ignispixel.com/product/ignis-pixel-poi-104-hd>

Ignis 144 HD are fully programmable poi. They have everything you need — music synchronisation, ability to adjust up to 10 timelines using software for Windows and MacOS, and wireless control option (not included in standard digital poi set).

The poi are equipped with the following built-in features:

— Wireless Sync option – allows synchronizing the poi between each other and with other Ignis props. A perfect solution with many settings of group work to ensure sync work of props in big teams;

See, e.g., Ignis 144 HD product page, located at <https://ignispixel.com/product/ignis-pixel-poi-144-hd>

This is the favorite model of Ignis Pixel CEO Grigoriy Zhuravlev and artists from big shows, such as Circus of Zapashny brothers and Cirque du Soleil. Ignis 200 HD are also suitable for ladies and people with relatively short height — the total length of this model is 21.7 inch. The resolution of 200 pixels coupled with high rendering speed (2600 rows per second) allows to upload text, logos, emoji, graphic and detailed photos.

We also changed LEDs in new generation of Ignis Pixel 200 HD. New tiny LEDs show perfect colors with improved yellow and orange tones, that makes pictures on pois sharper, more realistic, and colorful. Synchronize your shows with music, adjust up to 10 timelines and make more money with our pixel equipment.

The poi are equipped with the following built-in features:

— Wireless Sync option – allows synchronizing the poi between each other and with other Ignis props. A perfect solution with many settings of group work to ensure sync work of props in big teams;

See, e.g., Ignis 200 HD product page, located at <https://ignispixel.com/product/ignis-pixel-poi-200-hd>

Upload logos, text, emoji, graphic, photos and don't bother — they will be recognisable at and in partial blackout. Synchronise your shows with music, adjust up to 10 timelines in our user-friendly software for Windows and Mac OS and make more money on your shows. We are sure, that these investments will pay off.

The poi are equipped with the following built-in features:

— Wireless Sync option – allows synchronizing the poi between each other and with other Ignis props. A perfect solution with many settings of group work to ensure sync work of props in big teams;

See, e.g., Ignis 256 HD product page, located at <https://ignispixel.com/product/ignis-pixel-poi-256-hd>

—● Bluetooth connection to a cellphone

Install Ignis Pixel App on your cell phone to get access to get full functions of Ignis product. Turn on Bluetooth on your phone to connect the device. Ignis mobile app allows to operate the device via your cellphone (to upload pictures, make timelines, launch and stop the device, change brightness of pictures and duration). If you have Smart or Ultimate versions, you can see detailed statistics in the app. You can operate more than one device synchronously. The app is available for both Android and iPhone versions.

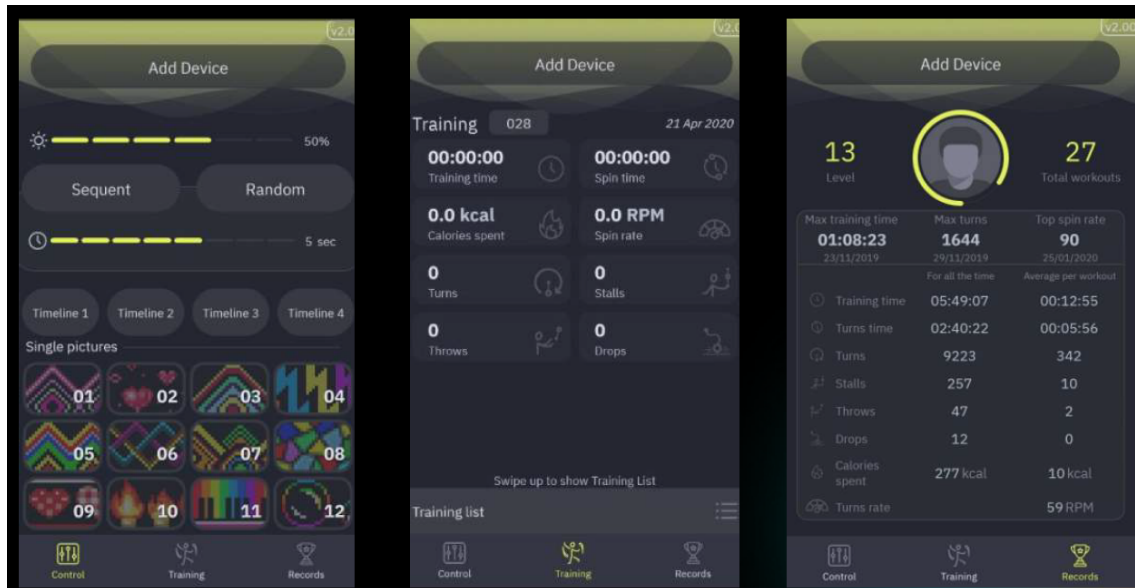

See, e.g., Manual for BubblePoi, JellyPoi 16/24 at page 10, located at https://assets.ipxl.ru/storage/product_file/a840f0829c769d4d707956f5ef77e4e1.pdf

187. The Pixel system comprises a rotatable assembly for displaying an image represented by at least a portion of the data transferred from said computer to the controller. For example, the Pixel system includes at least a collection of lighting devices able to, *inter alia*, be rotated about an axis and selectively turn said lighting devices on and off to display the one or more images represented by the data chosen by the user and received from the computer (*see above re computer*) by the controller:

Programming timeline modes (time-programmed sequence of pictures).

You can set the duration for each uploaded picture, thus creating a sequence of them, synchronized with the music. There are ten timeline custom sequences, T1-T10.

To configure the timeline:

1. Run Ignis Pixel Utility;
2. Open single pictures from files through menu **Add -> Image** or drag and drop files to the Image list into the left upper area of Ignis Pixel Utility;
3. Select images in Image list, drag and drop them to a timeline (T1-T10) to the lower area of Ignis Pixel Utility;
4. Now you see a sequence of pictures. You can change their order and duration by dragging them or their borders, like in video editors. Use Ctrl (Cmd for MacOS) button to change editing method Ripple edit/Rolling edit;
5. To adjust the timeline synchronously with music, add your music file through menu **Add -> Music** or drag and drop an MP3 file to the Music slot of Ignis Pixel Utility (lower area, just above the timelines);
6. Connect your digital poi to your computer with Micro-USB cables and press **Scan** button in the **Device list** (right area of Ignis Pixel Utility);
7. Click **"Upload all"** button – the process can take up to several minutes depending on the poi model and height-width ratios of the pictures.
8. When you change only a duration or an order of pictures in a timeline to save time, just tick the required timeline and click **"Upload Checked"** – the process will take just a few seconds.

Saving your project

The software allows you to save the project, and you can send your project by e-mail or USB flash to another computer. You do not need to send the original pictures of your project. They are contained within the project file.

See, e.g., Manual for Ignis Pixel Poi at page 4, located at https://ignispixel.com/files/upload/manual/Manual_Ignis_Pixel_v3_EN.pdf

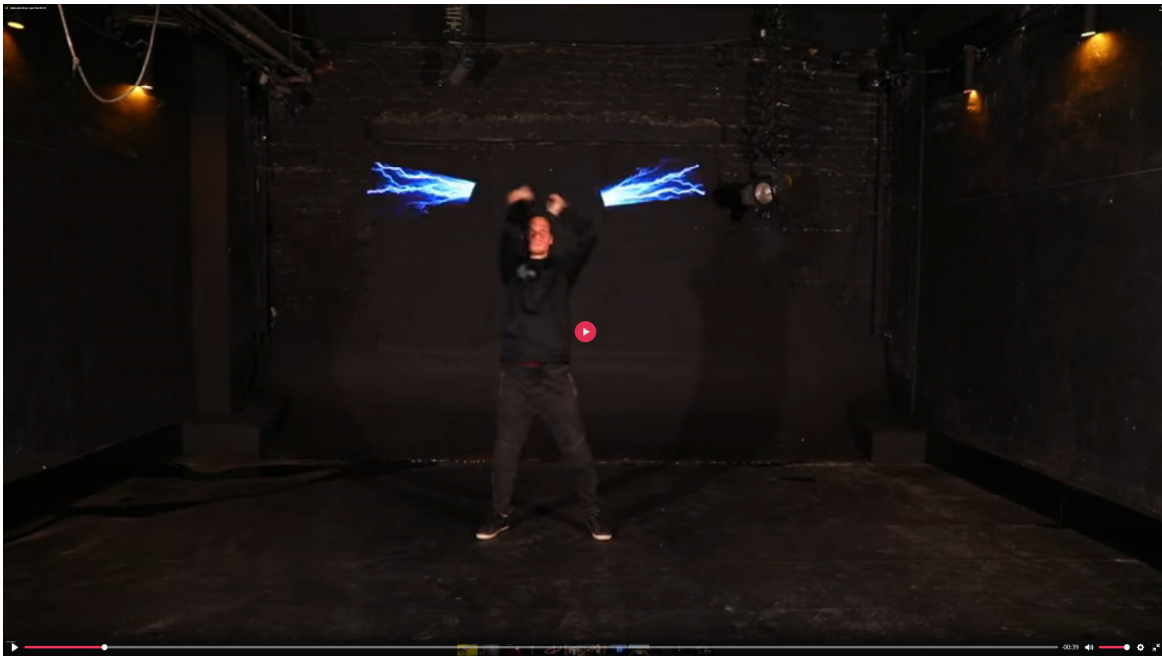
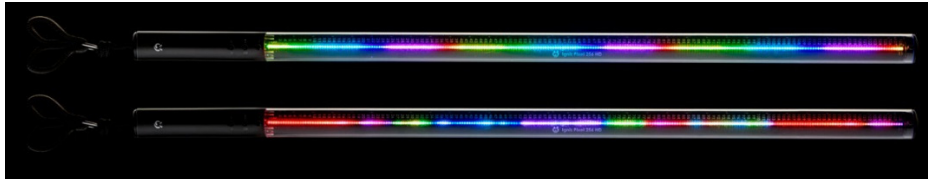

See, e.g., Ignis 256 HD product page, located at <https://ignispixel.com/product/ignis-pixel-poi-256-hd>





See, e.g., Ignis 200 HD product page, located at <https://ignispixel.com/product/ignis-pixel-poi-200-hd>

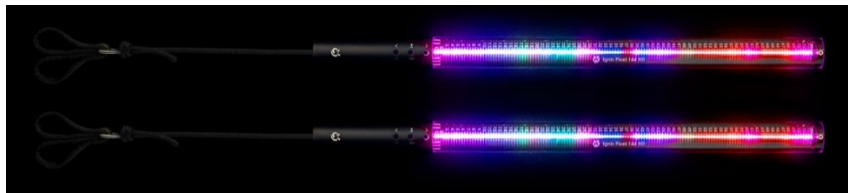

See, e.g., Ignis 144 HD product page, located at <https://ignispixel.com/product/ignis-pixel-poi-144-hd>

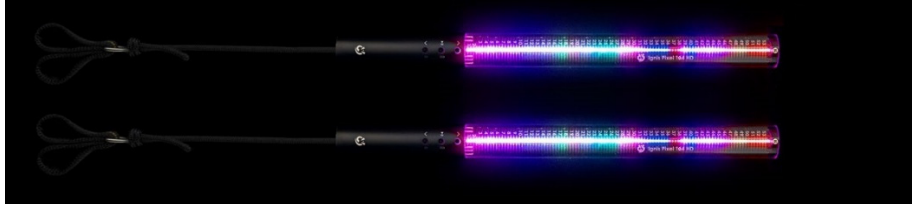

See, e.g., Ignis 104 HD product page, located at <https://ignispixel.com/product/ignis-pixel-poi-104-hd>





See, e.g., Ignis 80 HD product page, located at [https://ignispixel.com/product/ignis-poi-80-hd-tech](https://ignispixel.com/product/ignis-pixel-poi-80-hd-tech)



See, e.g., Ignis 48 SD product page, located at <https://ignispixel.com/product/ignis-pixel-poi-48-lite>



See, e.g., Ignis 32 SD product page, located at <https://ignispixel.com/product/ignis-pixel-poi-32-tech>

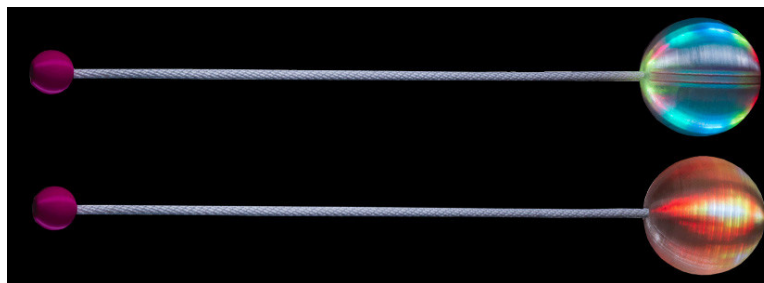

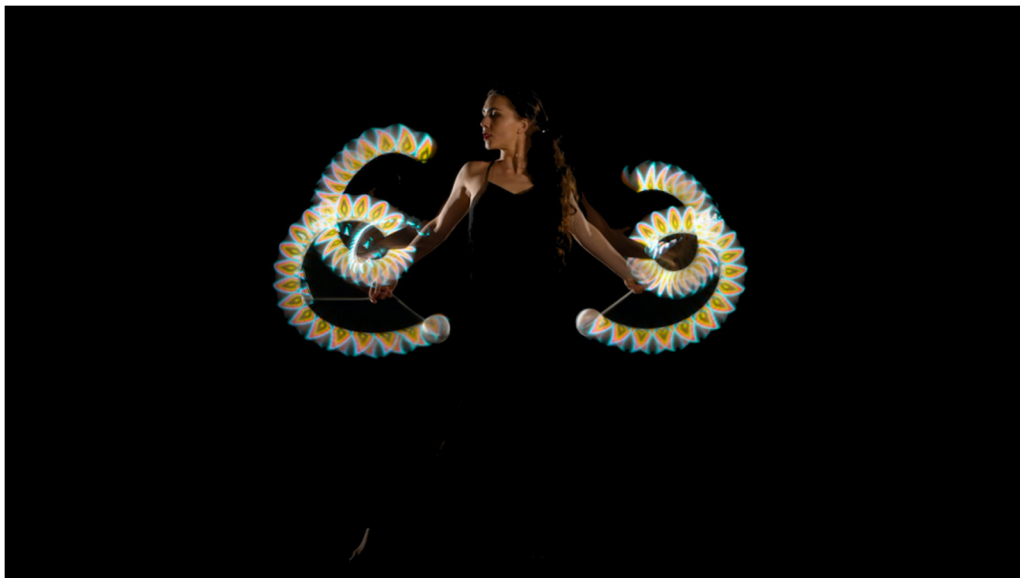

See, e.g., Ignis BubblePoi 16 product page, located at <https://ignispixel.com/product/bubble-led-poi-16-48-leds-basic>

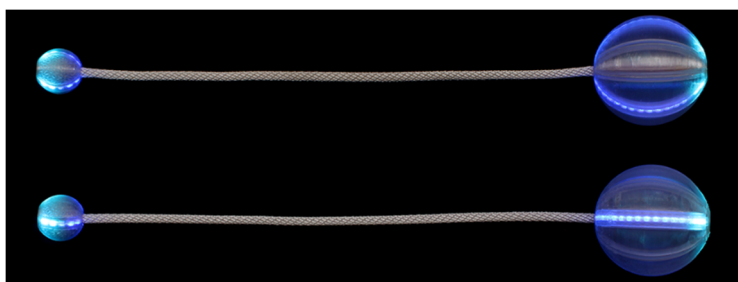

See, e.g., Ignis BubblePoi 16 & Pixel Knobs product page, located at <https://ignispixel.com/product/bubble-led-poi-16-48-leds-pixel-knob>

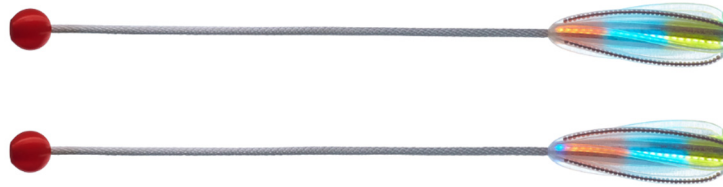

See, e.g., Ignis JellyPoi 24 product page, located at <https://ignispixel.com/product/ignis-pixel-jellypoi-24-basic>



See, e.g., Ignis JellyPoi 24 & Pixel Knobs product page, located at <https://ignispixel.com/product/ignis-pixel-jellypoi-24-with-knob>

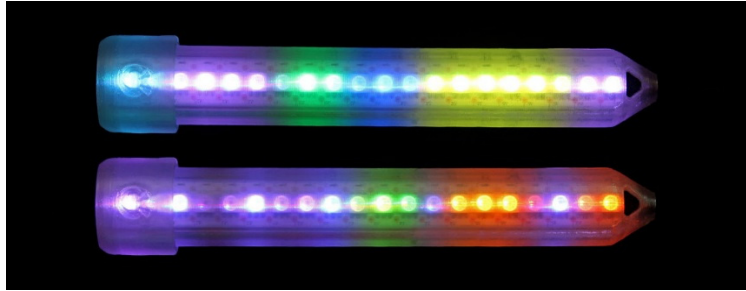





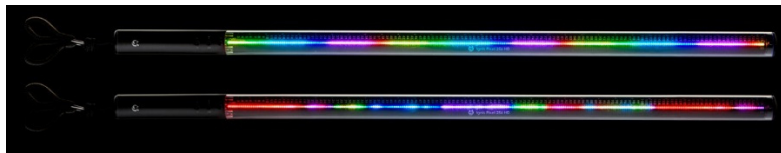



See, e.g., Ignis Stick 20 & Stick 20 Smart product page, located at <https://ignispixel.com/product/ignis-pixel-stick>

188. The Pixel system comprises the rotatable assembly including an illuminating display, said illuminating assembly being operably connected to said controller, said illuminating assembly including at least one illuminating element. For example, the Pixel system includes at least a collection or group of LEDs attached and/or connected, including via electric circuitry, to the controller for control and/or operation of the illuminating assembly, *inter alia*, by the controller:



The resolution of 256 pixels is the highest resolution on a pixel staff market. We fit 256 LEDs in 21.7 inch and supplied Ignis 256 HD with high rendering speed (2400 rows per second). The length of this LED poi is quite big, so all pictures are recognisable from big stages. High resolution, bright colors (8,6 billion) and high-rendering speed allow to astonish every single spectacular. This LED poi set is the best choice for people who love to amaze others and want to be at the cutting edge of technologies.





Technical characteristics



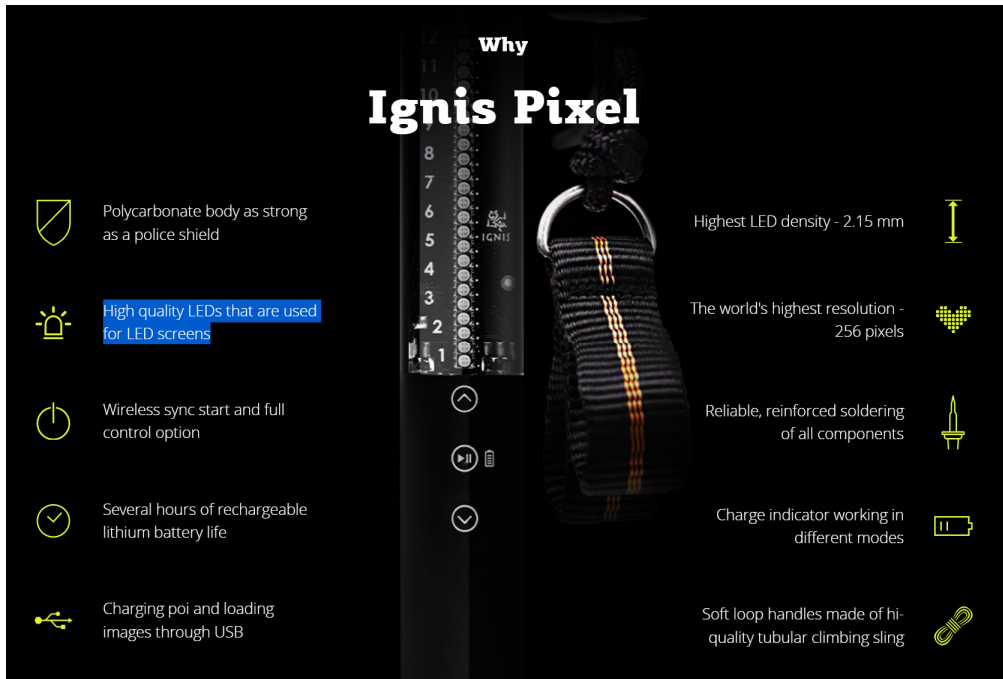

-  Resolution: 256 pixels (512 LEDs)
-  Rendering speed: 2400 rows/second
-  Total length of poi: 67 cm (26.4")
-  Length of LED part: 55 cm (21.7")
-  Weight: 210 g (7.41 oz.)
-  Working time: 1.4h average; 15 min full white; up to 4h low brightness
-  Number of colors: 8.6 billion (Color depth 33 bit)
-  Battery capacity: 3500 mAh

Why

Ignis Pixel



-  Polycarbonate body as strong as a police shield
-  High quality LEDs that are used for LED screens
-  Wireless sync start and full control option
-  Several hours of rechargeable lithium battery life
-  Charging poi and loading images through USB









- Highest LED density - 2.15 mm 
- The world's highest resolution - 256 pixels 
- Reliable, reinforced soldering of all components 
- Charge indicator working in different modes 
- Soft loop handles made of hi-quality tubular climbing sling 

See, e.g., Ignis 256 HD product page, located at <https://ignispixel.com/product/ignis-pixel-poi-256-hd>



We also changed LEDs in new generation of Ignis Pixel 200 HD. New tiny LEDs show perfect colors with improved yellow and orange tones, that makes pictures on pois sharper, more realistic, and colorful. Synchronize your shows with music, adjust up to 10 timelines and make more money with our pixel equipment.

Technical characteristics

-  Resolution: 200 pixels (400 LEDs)
-  Rendering speed: 2600 rows/second
-  Total length of poi: 55 cm (21.7")
-  Length of LED part: 43 cm (16.9")
-  Weight: 190 g (6.7 oz.)
-  Working time: 1.5h average; 20 min full white; up to 5h low brightness
-  Number of colors: 8.6 billion (Color depth 33 bit)
-  Battery capacity: 3500 mAh

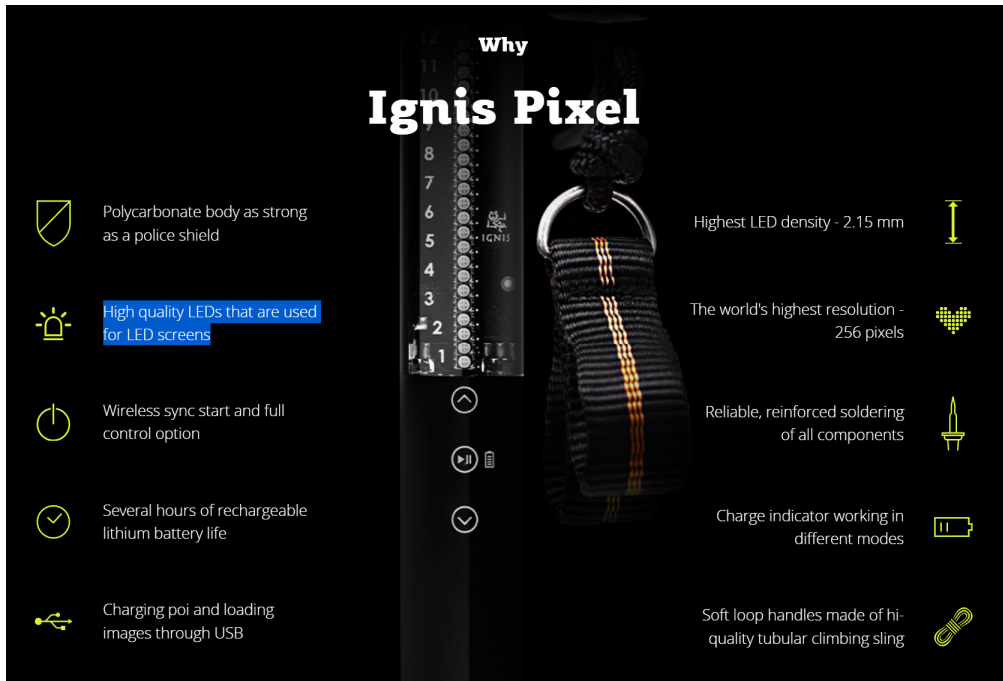



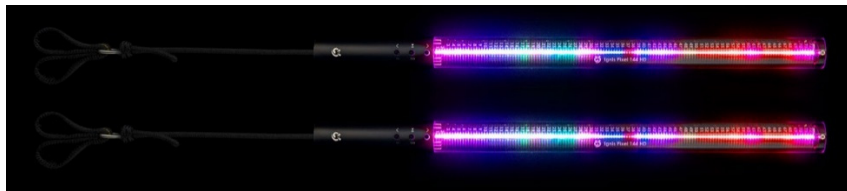





See, e.g., Ignis 200 HD product page, located at <https://ignispixel.com/product/ignis-pixel-poi-200-hd>



Ignis 144 HD are best for big show groups. This LED poi set allows to make technically advanced tricks such as spirals. Ignis 144 HD are also easily transformed into a doublestaff with the length of 34,2 inches and the world's highest resolution of 288 pixels. With these characteristics we guarantee that photos, logos, texts, and other graphic will be bright and readable not only at night, but also at lamplight.











Technical characteristics

-  Resolution: 144 pixels **(288 LEDs)**
-  Rendering speed: 3500 rows/second
-  Total length of poi: 44 cm (17.3")
-  Length of LED part: 31 cm (12.2")
-  Weight: 160 g (5.64 oz.)
-  Working time: 2h average; 26 min full white; up to 6h low brightness
-  Number of colors: 8.6 billion (Color depth 33 bit)
-  Battery capacity: 2600 mAh

Why

Ignis Pixel







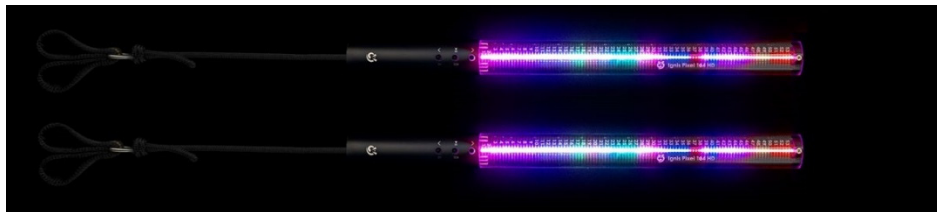



<ul style="list-style-type: none">  Polycarbonate body as strong as a police shield  High quality LEDs that are used for LED screens  Wireless sync start and full control option  Several hours of rechargeable lithium battery life  Charging poi and loading images through USB 	<ul style="list-style-type: none"> Highest LED density - 2.15 mm  The world's highest resolution - 256 pixels  Reliable, reinforced soldering of all components  Charge indicator working in different modes  Soft loop handles made of hi-quality tubular climbing sling 
--	--

See, e.g., Ignis 144 HD product page, located at <https://ignispixel.com/product/ignis-pixel-poi-144-hd>



LED poi Ignis 104 HD is shortest digital poi with high 104-pixel resolution. Length of poi is only 35 cm, which is suitable for performing technically advanced spinning with elements such as spirals, wraps and even orbitals. 104 LEDs mounted with pitch 2,1 mm to each other and allows you to draw in the air not only pictures but also photos with faces of people who are easily recognized by the audience!

Technical characteristics

-  Resolution: 104 pixels (208 LEDs)
-  Rendering speed: 2600 rows/second
-  Total length of poi: 35 cm (13.8")
-  Length of LED part: 23 cm (9.1")
-  Weight: 140 g (4.94 oz.)
-  Working time: 2h average; 42 min full white; 5h low brightness
-  Number of colors: 8.6 billion (Color depth 33 bit)
-  Battery capacity: 2600 mAh

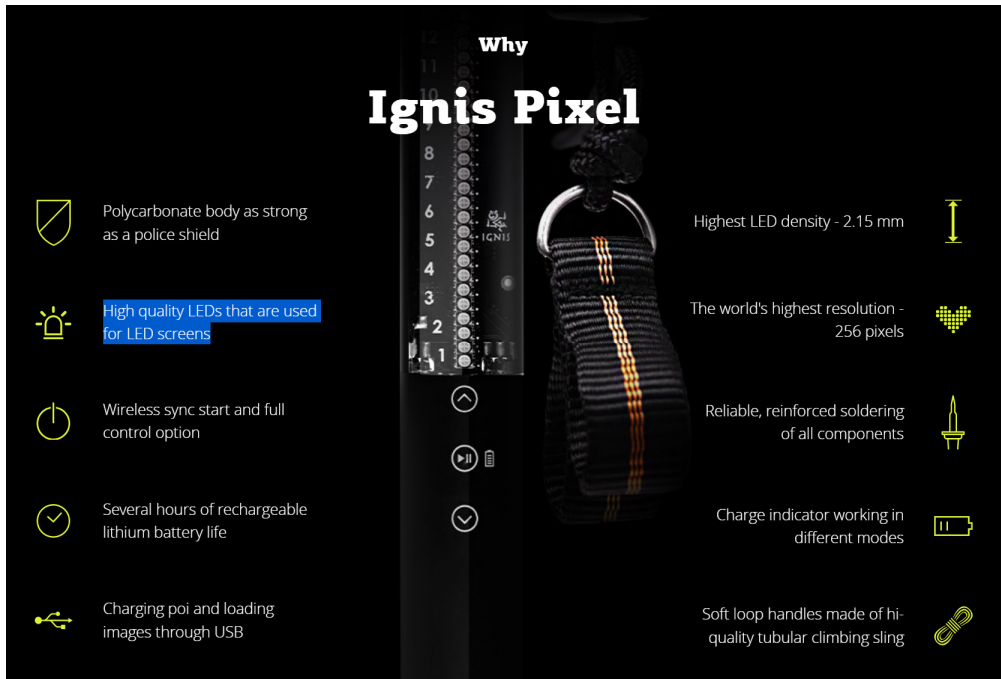

See, e.g., Ignis 104 HD product page, located at <https://ignispixel.com/product/ignis-pixel-poi-104-hd>



Ignis 80 HD Tech is our flagship model for professional spinners. Ignis 80 HD Tech has the best balance between length, number of LEDs, and resolution on the market of pixel equipment. At first we made this model for such profiles as Tim Goddard (@timmehtek) from Australia, Yuta Imamura (@yutapoi) from Japan, Ben Drexler (@drexfactor) from the USA, Gustavo Ollitta (@gollitta) from Brazil, but decided that Ignis 80 HD Tech deserves attention of other professionals. Short length (6.7 inch) allows to do spirals, wraps, orbitals, hyperloops and even juggling them. And due to the high resolution of 80 pixels, you can upload to this LED poi set texts, emoji, logos, graphic and also photos with people's faces and small details. Work with programmable LED poi sticks in the user-friendly software compatible with Windows and Mac OS. If our world record in resolution doesn't make sense to you, than pay attention to the rendering speed — 3 000 rows per second!

Technical characteristics

- Resolution: 80 pixels (160 LEDs)
- Rendering speed: 3000 rows/second
- Total length of poi: 29.5 cm (11.6")
- Length of LED part: 17 cm (6.7")
- Weight: 130 g (4.59 oz.)
- Working time: 2h average; 40 min full white; 5h low brightness
- Number of colors: 68 billion (Color depth 36 bit)
- Battery capacity: 2600 mAh

The image shows a product page for the Ignis Pixel poi. At the top, it says "Why Ignis Pixel". The central image shows the poi with a digital display on its handle. Surrounding this are several features listed with icons:









- Polycarbonate body as strong as a police shield
- High quality LEDs that are used for LED screens
- Wireless sync start and full control option
- Several hours of rechargeable lithium battery life
- Charging poi and loading images through USB
- Highest LED density - 2.15 mm
- The world's highest resolution - 256 pixels
- Reliable, reinforced soldering of all components
- Charge indicator working in different modes
- Soft loop handles made of high-quality tubular climbing sling

See, e.g., Ignis 80 HD product page, located at <https://ignispixel.com/product/ignis-pixel-poi-80-hd-tech>



Ignis Pixel 48 Lite are best for those who aren't ready for huge investments in digital props, but have already started to make performances. Do wraps, spirals, orbitals, hyperloops and our poi sticks will take care of everything else — they are so bright that your show will be noticeable from a distance. For this purpose we supplied them with 96 bright LEDs, that help to see all pictures at night, lamplight and even in daylight.

Technical characteristics

-  Resolution: 48 pixels (96 LEDs)
-  Rendering speed: 1500 rows/second
-  Total length of poi: 37 cm (14.6")
-  Length of LED part: 24 cm (9.4")
-  Weight: 150 g (5.29 oz.)
-  Working time: Working time: 1,5h average; 32 min full white; 4h low brightness
-  Number of colors: 68 billion (Color depth 36 bit)
-  Battery capacity: 2600 mAh

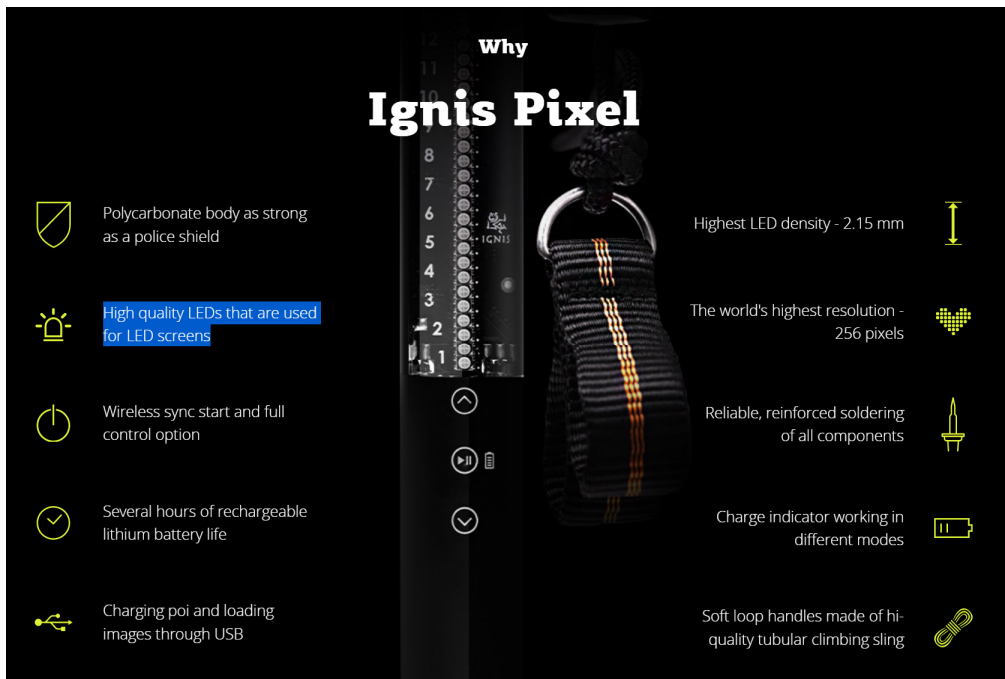

The graphic is a dark-themed advertisement for the Ignis Pixel poi. At the top center, the word "Why" is written in a small font, followed by "Ignis Pixel" in a large, bold, white font. Below this, a central image shows a black poi with a silver ring and a black handle with orange and yellow stripes. To the left of the poi, there are five icons with corresponding text: a shield for "Polycarbonate body as strong as a police shield", a lightbulb for "High quality LEDs that are used for LED screens", a power button for "Wireless sync start and full control option", a checkmark for "Several hours of rechargeable lithium battery life", and a USB symbol for "Charging poi and loading images through USB". To the right of the poi, there are three icons with corresponding text: a vertical double-headed arrow for "Highest LED density - 2.15 mm", a grid of dots for "The world's highest resolution - 256 pixels", a soldering iron for "Reliable, reinforced soldering of all components", a battery icon for "Charge indicator working in different modes", and a climbing sling for "Soft loop handles made of high-quality tubular climbing sling".

See, e.g., Ignis 48 SD product page, located at <https://ignispixel.com/product/ignis-pixel-poi-48-lite>



Short length and simplicity are the main advantages of this LED poi set. In the hands of professional artists Ignis Pixel 32 Tech become a huge weapon for making technically advanced tricks, such as spirals, wraps, orbitals, and even hyperloops due to bearing swivels. They also can become your best teacher if you start to spin a LED staff recently. Ignis Pixel 32 Tech have optimal length (11.4 inch), weight (4.2 oz) and are very user-friendly.

Technical characteristics

- Resolution: 32 pixels (64 LEDs)
- Rendering speed: 1500 rows/second
- Total length of poi: 29 cm (11.4")
- Length of LED part: 16 cm (6.3")
- Weight: 130 g (4.59 oz.)
- Working time: Working time: 1,5h average; 30 min full white; 4h low brightness
- Number of colors: 68 billion (Color depth 36 bit)
- Battery capacity: 2600 mAh





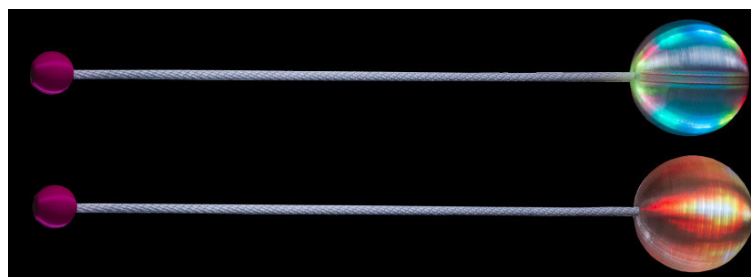



The image shows a product page for the Ignis Pixel poi. At the top, it says "Why Ignis Pixel". The central image shows the poi with a black body and orange and yellow LED strips. To the left, there are five features listed with icons: a shield for "Polycarbonate body as strong as a police shield", a lightbulb for "High quality LEDs that are used for LED screens", a power button for "Wireless sync start and full control option", a checkmark for "Several hours of rechargeable lithium battery life", and a USB symbol for "Charging poi and loading images through USB". To the right, there are three more features: a vertical ruler for "Highest LED density - 2.15 mm", a grid of pixels for "The world's highest resolution - 256 pixels", and a soldering iron for "Reliable, reinforced soldering of all components". Below that, a battery icon is next to "Charge indicator working in different modes", and a climbing sling icon is next to "Soft loop handles made of hi-quality tubular climbing sling".

See, e.g., Ignis 32 SD product page, located at <https://ignispixel.com/product/ignis-pixel-poi-32-tech>



Ignis BubblePoi 16 are the brightest programmable LED poi of spherical shape for juggling and contact spinning. Owing to soft material, they are safe to spin. The shape, weight and size are almost identical to those contact poi you get used to spinning and juggling.

Technical characteristics

-  Resolution: 16 pixels (48 LEDs)
-  Rendering speed: 1250 rows/second
-  Total length of poi: 9.6 cm (3.8")
-  Length of LED part: 9.6 cm (3.8")
-  Weight: Adjustable 140-190 g (4.9-6.7 oz.)
-  Working time: 14h average; 1h full white; up to 50h low brightness
-  Number of colors: 16,7 million (Color depth 24 bit)
-  Battery capacity: from 2600 mAh to 3500 mAh





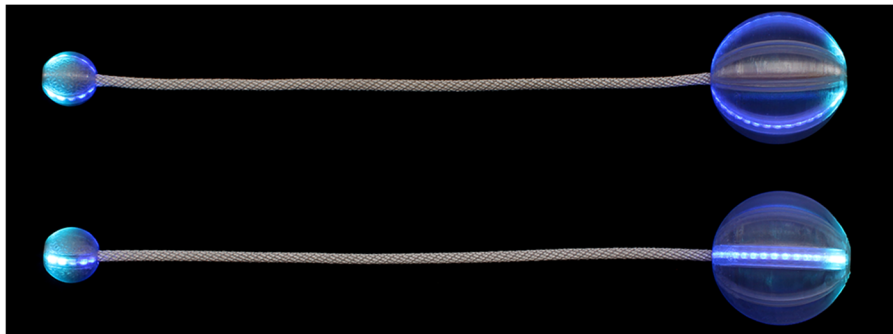





See, e.g., Ignis BubblePoi 16 product page, located at <https://ignispixel.com/product/bubble-led-poi-16-48-leds-basic>



Ignis BubblePoi 16 are the brightest programmable LED poi of spherical shape for juggling and contact spinning. Owing to soft material, they are safe to spin. The shape, weight and size are almost identical to those contact poi you get used to spinning and juggling.

Technical characteristics

-  Resolution: Poi: 16 pixels (48 LEDs); Knobs 5 pixels (15 LEDs)
-  Rendering speed: up to 2500 rows/second
-  Total length of poi: 9,6
-  Length of LED part: 9.6 cm (3.8")
-  Weight: 140-190 g (4.9-6.7 oz.)
-  Working time: Poi: 6h average; 1 hour full white; 15 h low brightness; Knobs: 4h average; 40 min full white; 10h low brightness
-  Diameter of poi: Poi: 96 mm (3,78 inches); Knobs: 35 mm (1.4 inches)
-  Number of colors: 16,7 million (Color depth 24 bit)
-  Battery capacity: from 2600 mAh to 3500 mAh

Total glowing

Three rows of LEDs from butt to top with no dead zones. The number of LEDs and brightness is 50% more than those of JellyPoi.





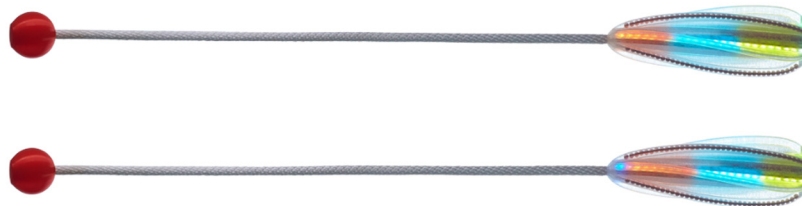





See, e.g., Ignis BubblePoi 16 & Pixel Knobs product page, located at <https://ignispixel.com/product/bubble-led-poi-16-48-leds-pixel-knob>



JellyPoi 24 is an entire pixel body poi with a soft case, unique spiral geometry with 3 rows of LEDs, located from edge to edge, no dead zones and 24 pixels high. The soft case effectively protects you and poi during impacts and bumps, preserving the unique clarity of the pattern in the loop, while having increased brightness, which is now 2.25x more than in the JellyPoi 16 model.

Technical characteristics

-  Resolution: 24 pixels (72 LEDs)
-  Rendering speed: 2500 rows/second
-  Total length of poi: 17 cm (6.7")
-  Length of LED part: 17 cm (6.7")
-  Weight: Adjustable 115-195 g (4-6.9 oz.)
-  Working time: 9h average; 40 min full white; up to 40h low brightness
-  Number of colors: 16,7 million (Color depth 24 bit)
-  Battery capacity: from 2600 mAh to 3500 mAh

Total glowing

Three rows of LEDs from butt to top with no dead zones. The number of LEDs and brightness is 50% more than those of JellyPoi.





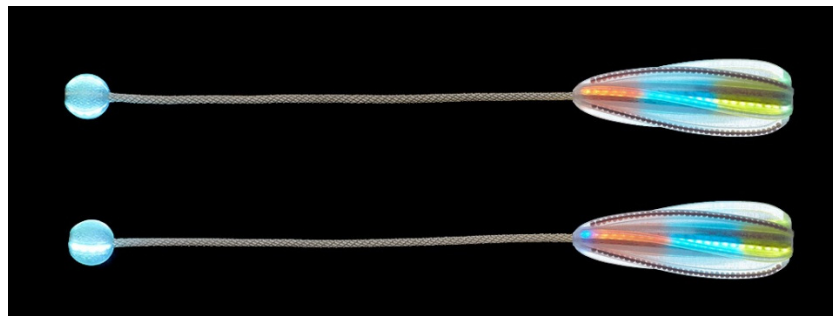





See, e.g., Ignis JellyPoi 24 product page, located at <https://ignispixel.com/product/ignis-pixel-jellypoi-24-basic>



JellyPoi 24 is an entire pixel body poi with a soft case, unique spiral geometry with 3 rows of LEDs, located from edge to edge, no dead zones and 24 pixels high. The soft case effectively protects you and poi during impacts and bumps, preserving the unique clarity of the pattern in the loop, while having increased brightness, which is now 2.25x more than in the JellyPoi 16 model.

Technical characteristics

-  Resolution: Poi: 24 pixels (72 LEDs); Knobs: 5 pixels (15 LEDs)
-  Rendering speed: 2500 rows/second
-  Total length of poi: 17 cm (6.7")
-  Length of LED part: 17 cm (6.7")
-  Weight: Adjustable 115-195 g (4-6.9 oz.)
-  Working time: 9h average; 40 min full white; up to 40h low brightness
-  Number of colors: 16,7 million (Color depth 24 bit)
-  Battery capacity: from 2600 mAh to 3500 mAh

Total glowing

Three rows of LEDs from butt to top with no dead zones. The number of LEDs and brightness is 50% more than those of JellyPoi.





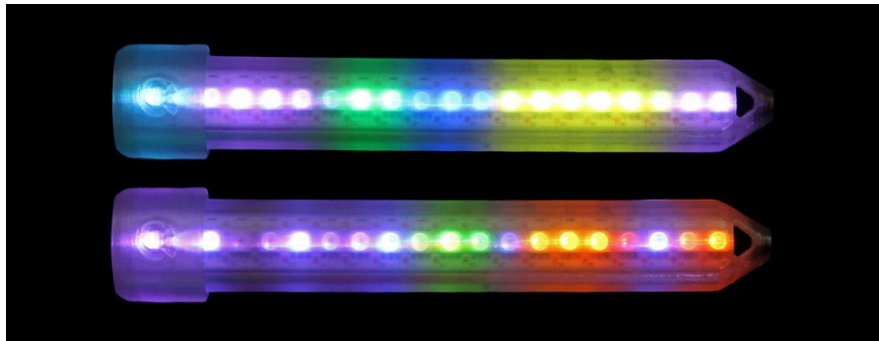





See, e.g., Ignis JellyPoi 24 & Pixel Knobs product page, located at <https://ignispixel.com/product/ignis-pixel-jellypoi-24-with-knob>



Ignis Stick 20 are lightweight poi in shape of glow sticks for fast and super fast twirling also known as glowstringing/glowsticking. 3d printed from shockproof polyurethane makes these poi durable and convenient for manipulation, weighting only 52 grams. Pixel poi casing contains 2 rows of LEDs, 20 in each, located along the entire length without dead zones. Amazing brightness per size ratio.

Technical characteristics

-  Resolution: 20 pixels (40 LEDs)
-  Rendering speed: 2500 rows/second
-  Total length of poi: 15 cm (5.9")
-  Length of LED part: 15 cm (5.9")
-  Weight: 52 g (1.83 oz.)
-  Working time: 4h average; 27 min full white; up to 20h low brightness
-  Number of colors: 16,7 million (Color depth 24 bit)
-  Battery capacity: 750 mAh

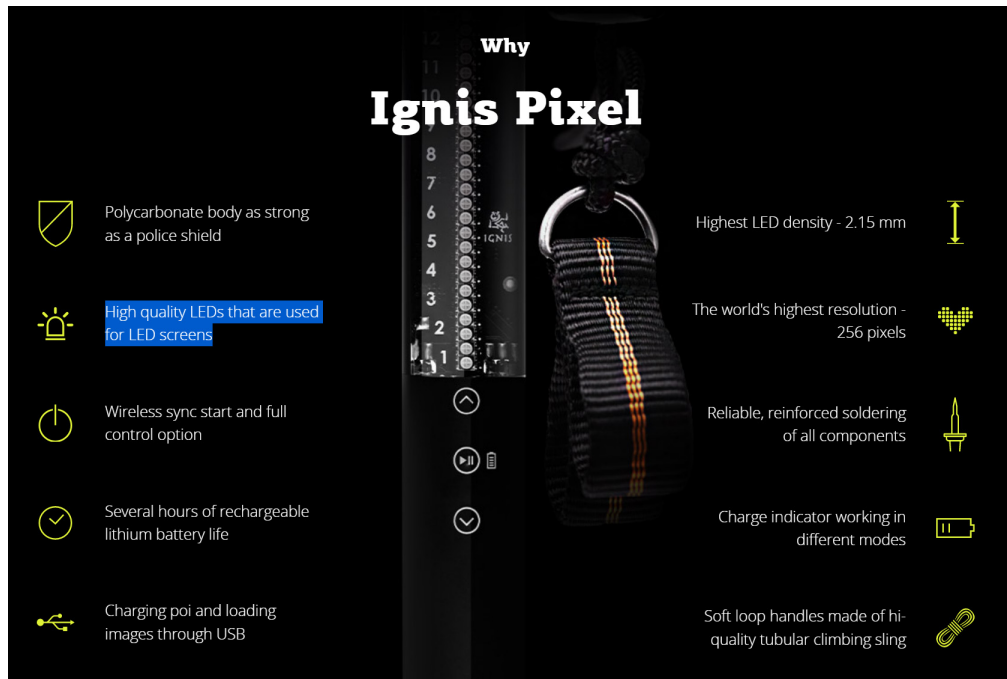

See, e.g., Ignis Stick 20 & Stick 20 Smart product page, located at <https://ignispixel.com/product/ignis-pixel-stick>

189. The Pixel system comprises the rotatable assembly being constructed and arranged for attachment to a support for rotation about an axis. For example, the Pixel system includes at least rope, string, or other similar material which, *inter alia*, permits the user to hold and/or keep a grip on the assembly, including while the user spins and/or rotates the assembly around an axis (e.g., around the user's arms, hands, body, etc.):

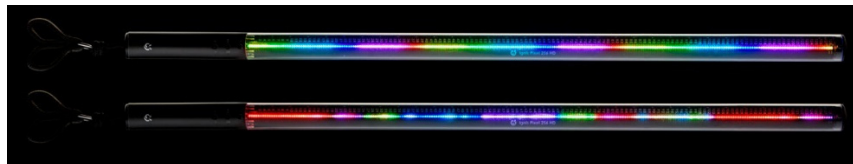



DESCRIPTION	SET INCLUDES	FILES
<p>The price is for a complete set, which includes:</p> <ul style="list-style-type: none">• Pair of Ignis 256 HD• Nylon loop handles with nylon cord• 2 Micro-USB cable for charging and upload pictures• Stylish two-ply bag with soft fleece lining		

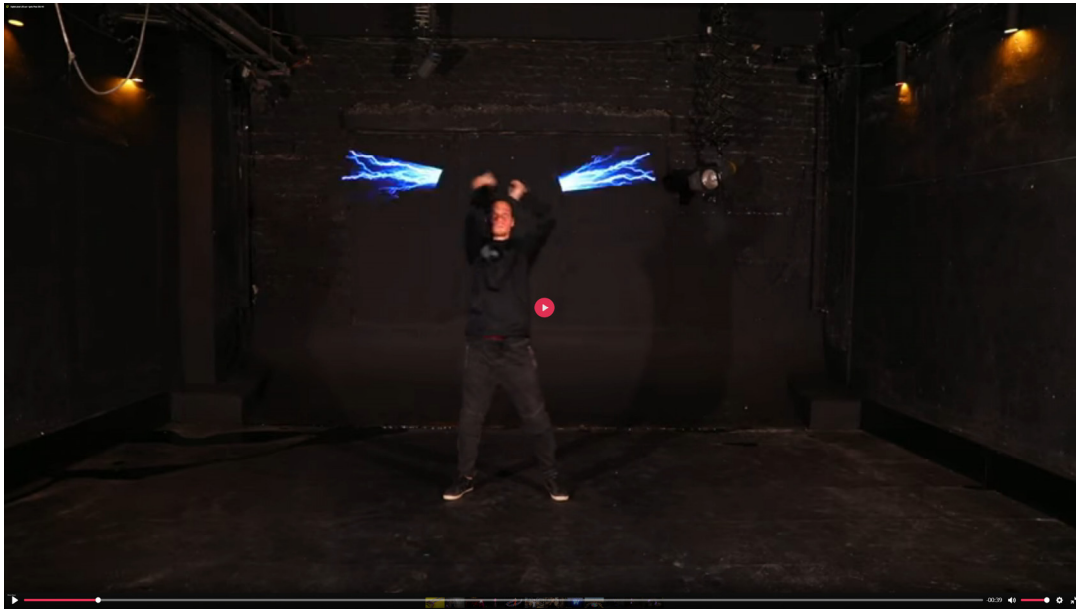

See, e.g., Ignis 256 HD product page, located at <https://ignispixel.com/product/ignis-pixel-poi-256-hd>



DESCRIPTION	SET INCLUDES	FILES
<p>The price is for a complete set, which includes:</p> <ul style="list-style-type: none">• Pair of Ignis 200 HD• Nylon loop handles with nylon cord• 2 Micro-USB cable for charging and upload pictures• Stylish two-ply bag with soft fleece lining		

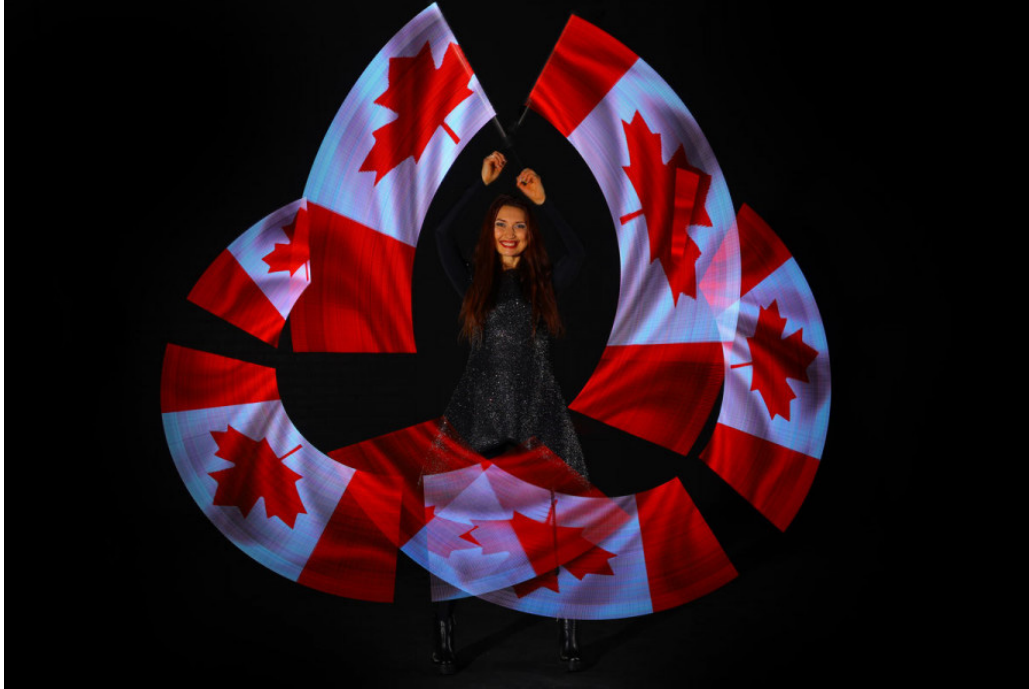

See, e.g., Ignis 200 HD product page, located at <https://ignispixel.com/product/ignis-pixel-poi-200-hd>

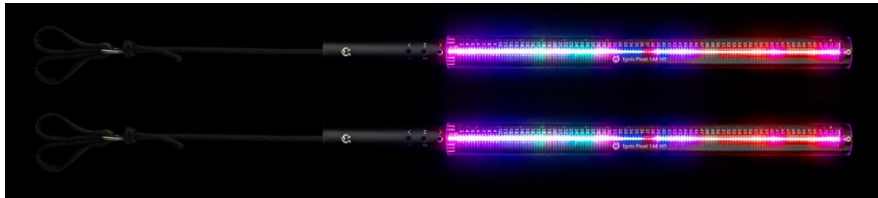

DESCRIPTION	SET INCLUDES	FILES
<p>The price is for a complete set, which includes:</p> <ul style="list-style-type: none">• Pair of Ignis 144 HD• Nylon loop handles with nylon cord• 2 Micro-USB cable for charging and upload pictures• Stylish two-ply bag with soft fleece lining		



See, e.g., Ignis 144 HD product page, located at <https://ignispixel.com/product/ignis-pixel-poi-144-hd>

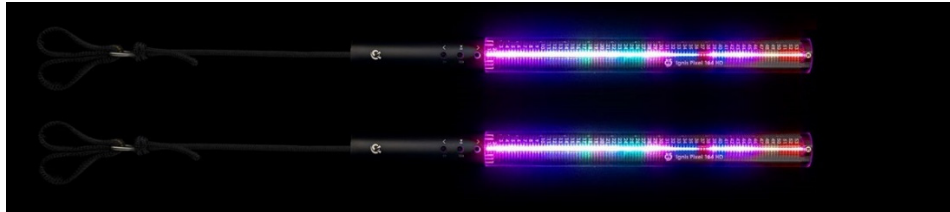

DESCRIPTION	SET INCLUDES	FILES
<p>The price is for a complete set, which includes:</p> <ul style="list-style-type: none">• Pair of Ignis 104 HD• Nylon loop handles with nylon cord• 2 Micro-USB cable for charging and upload pictures• Stylish two-ply bag with soft fleece lining		



See, e.g., Ignis 104 HD product page, located at <https://ignispixel.com/product/ignis-pixel-poi-104-hd>





DESCRIPTION

SET INCLUDES

FILES

The price is for a complete set, which includes:

- Pair of Ignis 80 HD
- Nylon loop handles with nylon cord
- 2 Micro-USB cable for charging and upload pictures
- Stylish two-ply bag with soft fleece lining



See, e.g., Ignis 80 HD product page, located at <https://ignispixel.com/product/ignis-pixel-poi-80-hd-tech>

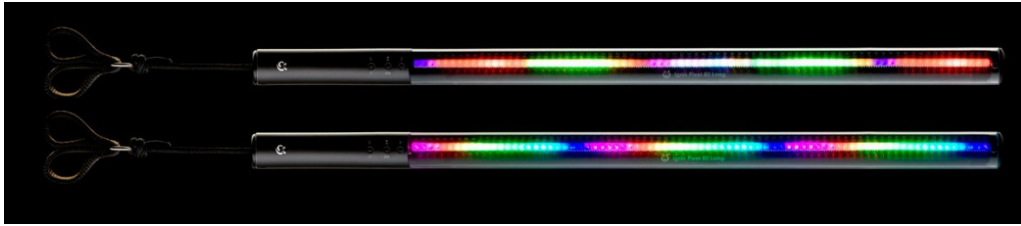

DESCRIPTION	SET INCLUDES	FILES
<p>The price is for a complete set, which includes:</p> <ul style="list-style-type: none">• Pair of Ignis 80 SD• Nylon loop handles with nylon cord• 2 Micro-USB cable for charging and upload pictures• Stylish two-ply bag with soft fleece lining		

See, e.g., Ignis 80 SD product page, located at <https://ignispixel.com/product/ignis-pixel-poi-80>



DESCRIPTION	SET INCLUDES	FILES
<p>The price is for a complete set, which includes:</p> <ul style="list-style-type: none">• Pair of Ignis 48 SD• Nylon loop handles with nylon cord• 2 Micro-USB cable for charging and upload pictures• Stylish two-ply bag with soft fleece lining		



See, e.g., Ignis 48 SD product page, located at <https://ignispixel.com/product/ignis-pixel-poi-48-lite>





DESCRIPTION

SET INCLUDES

FILES

The price is for a complete set, which includes:

- Pair of Ignis 32 SD
- Nylon loop handles with nylon cord
- 2 Micro-USB cable for charging and upload pictures
- Stylish two-ply bag with soft fleece lining



See, e.g., Ignis 32 SD product page, located at <https://ignispixel.com/product/ignis-pixel-poi-32-tech>

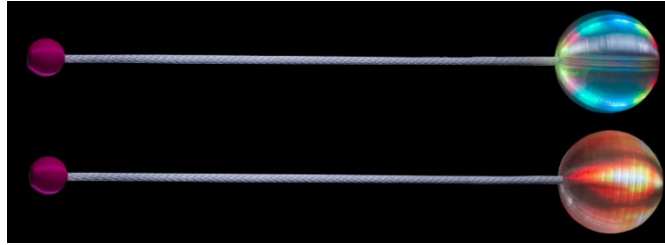

DESCRIPTION	SET INCLUDES	FILES
<p>The price is for a complete set, which includes:</p> <p>The price is for a complete set, which includes:</p> <ul style="list-style-type: none">• Pair of digital spherical poi Ignis BubblePoi 16• Pair of soft Knobs handles with weight adjustment• Nylon or Soft braided non-springy cord• 2 Micro-USB cables• Stylish bag• Mobile App Ignis Pixel• Basic set of images• User manual (pdf)		

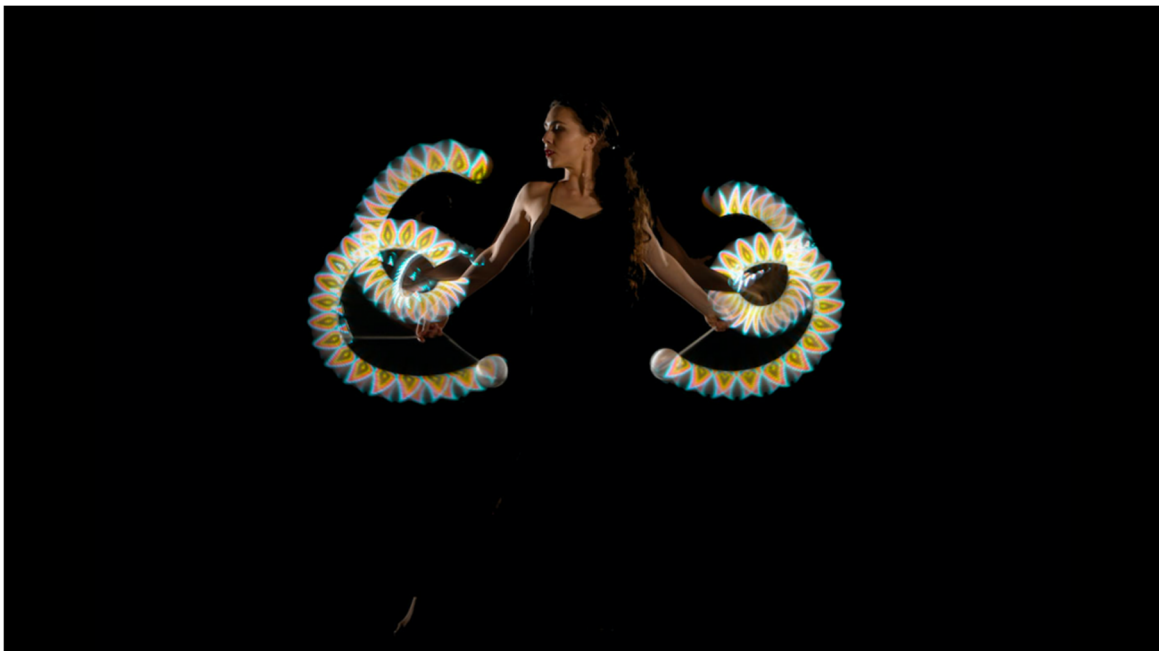

See, e.g., Ignis BubblePoi 16 product page, located at <https://ignispixel.com/product/bubble-led->

[poi-16-48-leds-basic](#)

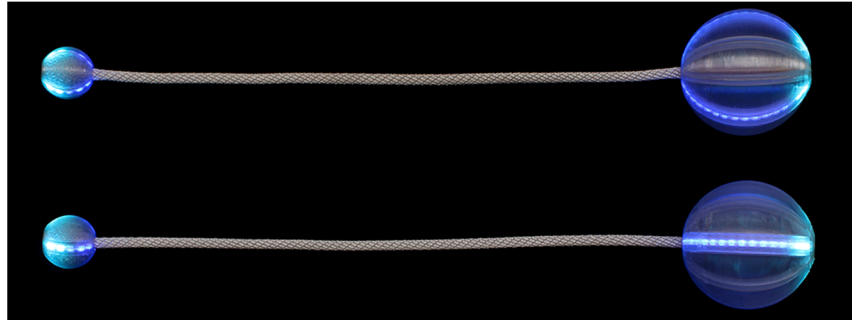

DESCRIPTION	SET INCLUDES	FILES
<p>The price is for a complete set, which includes:</p> <p>The price is for a complete set, which includes:</p> <ul style="list-style-type: none">• Pair of digital spherical poi Ignis BubblePoi 16• Pair of soft JellyKnobs handles with weight adjustment within 5-35 g (0.2-1.2 oz.)• Pair of Pixel Knob handles• Nylon or Soft braided non-springy cord• 4 Micro-USB cables• Stylish bag• Mobile App Ignis Pixel		



See, e.g., Ignis BubblePoi 16 & Pixel Knobs product page, located at <https://ignispixel.com/product/bubble-led-poi-16-48-leds-pixel-knob>

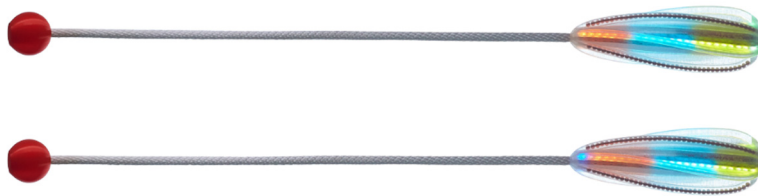

DESCRIPTION	SET INCLUDES	FILES
<p>The price is for a complete set, which includes:</p> <ul style="list-style-type: none">• Pair of digital poi Ignis JellyPoi 24• Pair of soft JellyKnobs handles with weight adjustment within 5-35 g (0.2-1.2 oz.)• Braided nylon cord• 2 Micro-USB cables• Stylish bag		



See, e.g., Ignis JellyPoi 24 product page, located at <https://ignispixel.com/product/ignis-pixel-jellypoi-24-basic>



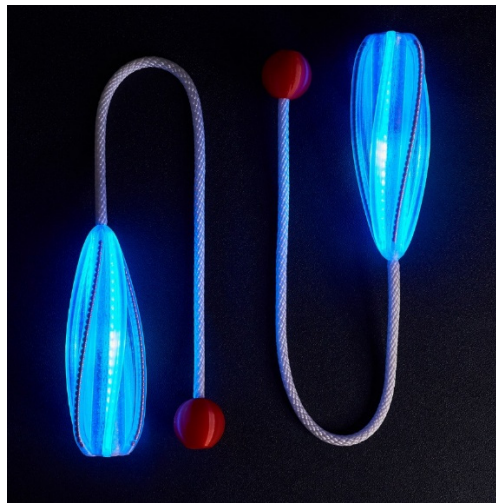

DESCRIPTION	SET INCLUDES	FILES
<p>The price is for a complete set, which includes:</p> <ul style="list-style-type: none">• Pair of digital poi Ignis JellyPoi 24• Pair of soft JellyKnobs handles with weight adjustment within 5-35 g (0.2-1.2 oz.)• Pair of pixel knob 5 handles• Braided cord• 4 Micro-USB cables• Stylish bag		

See, e.g., Ignis JellyPoi 24 & Pixel Knobs product page, located at <https://ignispixel.com/product/ignis-pixel-jellypoi-24-with-knob>

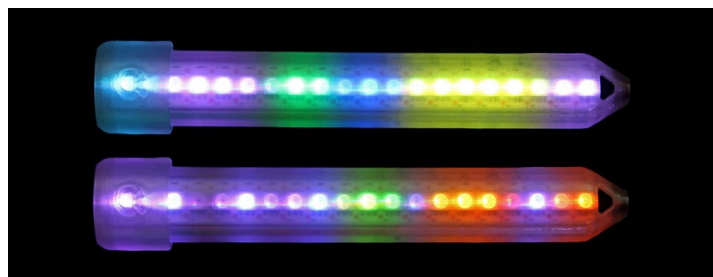

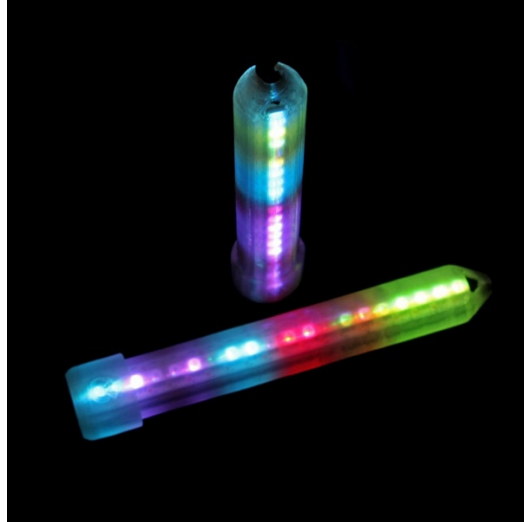









See, e.g., Ignis Stick 20 & Stick 20 Smart product page, located at <https://ignispixel.com/product/ignis-pixel-stick>

190. The Pixel system comprises a power delivery means for providing power to said rotatable assembly. For example, the Pixel system includes at least a battery contained within the Poi device which provides electric current to power the assembly and the illumination elements therein:





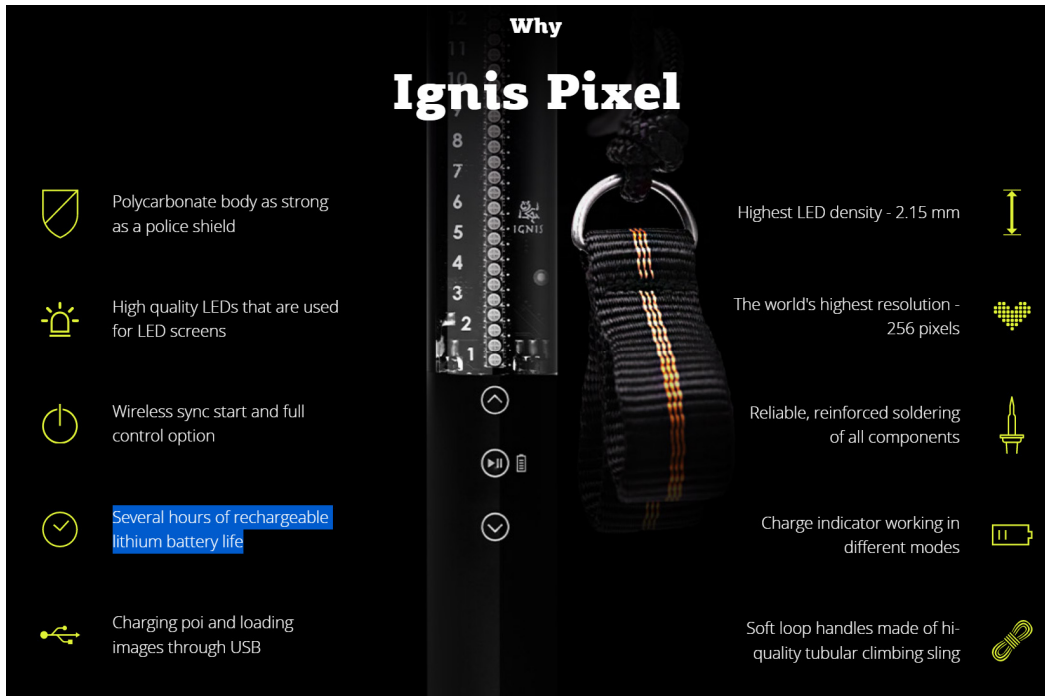



Technical characteristics

-  Resolution: 256 pixels (512 LEDs)
-  Rendering speed: 2400 rows/second
-  Total length of poi: 67 cm (26.4")
-  Length of LED part: 55 cm (21.7")
-  Weight: 210 g (7.41 oz.)
-  Working time: 1.4h average; 15 min full white; up to 4h low brightness
-  Number of colors: 8.6 billion (Color depth 33 bit)
-  Battery capacity: 3500 mAh



See, e.g., Ignis 256 HD product page, located at <https://ignispixel.com/product/ignis-pixel-poi-256-hd>

Technical characteristics

-  Resolution: 200 pixels (400 LEDs)
-  Rendering speed: 2600 rows/second
-  Total length of poi: 55 cm (21.7")
-  Length of LED part: 43 cm (16.9")
-  Weight: 190 g (6.7 oz.)
-  Working time: 1.5h average; 20 min full white; up to 5h low brightness
-  Number of colors: 8.6 billion (Color depth 33 bit)
-  **Battery capacity: 3500 mAh**

Why

Ignis Pixel

- Polycarbonate body as strong as a police shield
- High quality LEDs that are used for LED screens
- Wireless sync start and full control option
- Several hours of rechargeable lithium battery life
- Charging poi and loading images through USB
- Highest LED density - 2.15 mm
- The world's highest resolution - 256 pixels
- Reliable, reinforced soldering of all components
- Charge indicator working in different modes
- Soft loop handles made of hi-quality tubular climbing sling

See, e.g., Ignis 200 HD product page, located at <https://ignispixel.com/product/ignis-pixel-poi-200-hd>





Technical characteristics





- Resolution: 144 pixels (288 LEDs)
- Rendering speed: 3500 rows/second
- Total length of poi: 44 cm (17.3")
- Length of LED part: 31 cm (12.2")
- Weight: 160 g (5.64 oz.)
- Working time: 2h average; 26 min full white; up to 6h low brightness
- Number of colors: 8.6 billion (Color depth 33 bit)
- Battery capacity: 2600 mAh

Why

Ignis Pixel











-  Polycarbonate body as strong as a police shield
-  High quality LEDs that are used for LED screens
-  Wireless sync start and full control option
-  **Several hours of rechargeable lithium battery life**
-  Charging poi and loading images through USB











-  Highest LED density - 2.15 mm
-  The world's highest resolution - 256 pixels
-  Reliable, reinforced soldering of all components
-  Charge indicator working in different modes
-  Soft loop handles made of hi-quality tubular climbing sling

See, e.g., Ignis 144 HD product page, located at <https://ignispixel.com/product/ignis-pixel-poi-144-hd>

Technical characteristics









-  Resolution: 104 pixels (208 LEDs)
-  Rendering speed: 2600 rows/second
-  Total length of poi: 35 cm (13.8")
-  Length of LED part: 23 cm (9.1")
-  Weight: 140 g (4.94 oz.)
-  Working time: 2h average; 42 min full white; 5h low brightness
-  Number of colors: 8.6 billion (Color depth 33 bit)
-  **Battery capacity: 2600 mAh**

Why
Ignis Pixel

-  Polycarbonate body as strong as a police shield
-  High quality LEDs that are used for LED screens
-  Wireless sync start and full control option
-  Several hours of rechargeable lithium battery life
-  Charging poi and loading images through USB
-  Highest LED density - 2.15 mm
-  The world's highest resolution - 256 pixels
-  Reliable, reinforced soldering of all components
-  Charge indicator working in different modes
-  Soft loop handles made of hi-quality tubular climbing sling

See, e.g., Ignis 104 HD product page, located at <https://ignispixel.com/product/ignis-pixel-poi-104-hd>

Technical characteristics

-  Resolution: 80 pixels (160 LEDs)
-  Rendering speed: 3000 rows/second
-  Total length of poi: 29.5 cm (11.6")
-  Length of LED part: 17 cm (6.7")
-  Weight: 130 g (4.59 oz.)
-  Working time: 2h average; 40 min full white; 5h low brightness
-  Number of colors: 68 billion (Color depth 36 bit)
-  Battery capacity: 2600 mAh

Why

Ignis Pixel

Polycarbonate body as strong as a police shield

High quality LEDs that are used for LED screens

Wireless sync start and full control option

Several hours of rechargeable lithium battery life

Charging poi and loading images through USB

Highest LED density - 2.15 mm

The world's highest resolution - 256 pixels

Reliable, reinforced soldering of all components

Charge indicator working in different modes

Soft loop handles made of hi-quality tubular climbing sling

See, e.g., Ignis 80 HD product page, located at <https://ignispixel.com/product/ignis-pixel-poi-80-hd-tech>

Technical characteristics

- Resolution: 48 pixels (96 LEDs)
- Rendering speed: 1500 rows/second
- Total length of poi: 37 cm (14.6")
- Length of LED part: 24 cm (9.4")
- Weight: 150 g (5.29 oz.)
- Working time: Working time: 1,5h average; 32 min full white; 4h low brightness
- Number of colors: 68 billion (Color depth 36 bit)
- Battery capacity: 2600 mAh

Why

Ignis Pixel

- Polycarbonate body as strong as a police shield
- High quality LEDs that are used for LED screens
- Wireless sync start and full control option
- Several hours of rechargeable lithium battery life
- Charging poi and loading images through USB
- Highest LED density - 2.15 mm
- The world's highest resolution - 256 pixels
- Reliable, reinforced soldering of all components
- Charge indicator working in different modes
- Soft loop handles made of hi-quality tubular climbing sling

See, e.g., Ignis 48 SD product page, located at <https://ignispixel.com/product/ignis-pixel-poi-48-lite>





Technical characteristics





- Resolution: 32 pixels (64 LEDs)
- Resolution: 256
- Rendering speed: 1500 rows/second
- Total length of poi: 29 cm (11.4")
- Length of LED part: 16 cm (6.3")
- Weight: 130 g (4.59 oz.)
- Working time: Working time: 1,5h average; 30 min full white; 4h low brightness
- Number of colors: 68 billion (Color depth 36 bit)
- Battery capacity: 2600 mAh

Why

Ignis Pixel











-  Polycarbonate body as strong as a police shield
-  High quality LEDs that are used for LED screens
-  Wireless sync start and full control option
-  **Several hours of rechargeable lithium battery life**
-  Charging poi and loading images through USB

-  Highest LED density - 2.15 mm
-  The world's highest resolution - 256 pixels
-  Reliable, reinforced soldering of all components
-  Charge indicator working in different modes
-  Soft loop handles made of hi-quality tubular climbing sling

See, e.g., Ignis 32 SD product page, located at <https://ignispixel.com/product/ignis-pixel-poi-32-tech>

Technical characteristics

-  Resolution: 16 pixels (48 LEDs)
-  Rendering speed: 1250 rows/second
-  Total length of poi: 9.6 cm (3.8")
-  Length of LED part: 9.6 cm (3.8")
-  Weight: Adjustable 140-190 g (4.9-6.7 oz.)
-  Working time: 14h average; 1h full white; up to 50h low brightness
-  Number of colors: 16,7 million (Color depth 24 bit)
-  **Battery capacity: from 2600 mAh to 3500 mAh**

Powerful battery











Big battery with capacity 2600 mAh provides 2 times longer light time as compared to JellyPoi.
 Average working time - 6 hours
 In full white mode - 1 hour
 On low brightness - up to 15 hours.

BubblePoi feature set			
	Basic	Smart	Ultimate
Cord	Black braided nylon cord 7mm	Soft braided non-springy white cord 8mm	Soft braided non-springy white cord 8mm
Upload pictures support via application	Yes	Yes	Yes
Training statistics support via application	No	Yes	Yes
Image stabilization option	No	Yes	Yes
Static spin stabilization, time of rotation till full stop	No	up to 30 seconds	up to 5 minutes
Swivel inside the knob	No	Steel ball bearing	Corrode resistant ceramic bearing
Swivel inside the poi	No	Steel ball bearing	Corrode resistant ceramic bearing
Detachable cord, kinder ball/juggling ball/contact juggling functionality	Yes	Yes	Yes
Battery capacity	2600 mAh	2600 mAh	3500 mAh
Average light time on 50% brightness	~14 h	~14 h	~18 h
Price for set of 2 pois (contact with us to order 1 or 3 pois)	US \$287 US \$319 -10%	US \$368 US \$449 -12%	US \$441 US \$519 -15%

See, e.g., Ignis BubblePoi 16 product page, located at <https://ignispixel.com/product/bubble-led-poi-16-48-leds-basic>

Technical characteristics

-  Resolution: Poi: 16 pixels (48 LEDs); Knobs 5 pixels (15 LEDs)
-  Rendering speed: up to 2500 rows/second
-  Total length of poi: 9,6
-  Length of LED part: 9.6 cm (3.8")
-  Weight: 140-190 g (4.9-6.7 oz.)
-  Working time: Poi: 6h average; 1 hour full white; 15 h low brightness; Knobs: 4h average; 40 min full white; 10h low brightness
-  Diameter of poi: Poi: 96 mm (3,78 inches); Knobs: 35 mm (1.4 inches)
-  Number of colors: 16,7 million (Color depth 24 bit)
-  Battery capacity: from 2600 mAh to 3500 mAh

Powerful battery











Big battery with capacity 2600 mAh provides 2 times longer light time as compared to JellyPoi.
 Average working time - 6 hours
 In full white mode - 1 hour
 On low brightness - up to 15 hours.

BubblePoi feature set			
	Basic	Smart	Ultimate
Cord	Black braided nylon cord 7mm	Soft braided non-springy white cord 8mm	Soft braided non-springy white cord 8mm
Upload pictures support via application	Yes	Yes	Yes
Training statistics support via application	No	Yes	Yes
Image stabilization option	No	Yes	Yes
Static spin stabilization, time of rotation till full stop	No	up to 30 seconds	up to 5 minutes
Swivel inside the knob	No	Steel ball bearing	Corrode resistant ceramic bearing
Swivel inside the poi	No	Steel ball bearing	Corrode resistant ceramic bearing
Detachable cord, kinder ball/juggling ball/contact juggling functionality	Yes	Yes	Yes
Battery capacity	2600 mAh	2600 mAh	3500 mAh
Average light time on 50% brightness	~14 h	~14 h	~18 h
Price for set of 2 pois (contact with us to order 1 or 3 pois)	US \$287 US \$319 -10%	US \$368 US \$449 -12%	US \$441 US \$519 -15%

See, e.g., Ignis BubblePoi 16 & Pixel Knobs product page, located at <https://ignispixel.com/product/bubble-led-poi-16-48-leds-pixel-knob>

Technical characteristics

-  Resolution: 24 pixels (72 LEDs)
-  Rendering speed: 2500 rows/second
-  Total length of poi: 17 cm (6.7")
-  Length of LED part: 17 cm (6.7")
-  Weight: Adjustable 115-195 g (4-6.9 oz.)
-  Working time: 9h average; 40 min full white; up to 40h low brightness
-  Number of colors: 16,7 million (Color depth 24 bit)
-  **Battery capacity: from 2600 mAh to 3500 mAh**

Powerful battery



Big battery with capacity 2600 mAh provides 2 times longer light time as compared to JellyPoi.
 Average working time - 6 hours
 In full white mode - 1 hour
 On low brightness - up to 15 hours.

JellyPoi24 feature set			
	Basic	Smart	Ultimate
Cord	Black braided nylon cord 7mm	Soft braided non-springy white cord 8mm	Soft braided non-springy white cord 8mm
Upload pictures support via application	Yes	Yes	Yes
Training statistics support via application	No	Yes	Yes
Image stabilization option	No	Yes	Yes
Swivel inside the knob	No	Steel ball bearing	Corrode resistant ceramic bearing
Battery capacity	2600 mAh	2600 mAh	3500 mAh
Average light time on 50% brightness	~9 h	~9 h	~12 h
Price for set of 2 pois (contact with us to order 1 or 3 pois)	US \$377 US \$449 -10%	US \$456 US \$519 -12%	US \$526 US \$619 -15%

See, e.g., Ignis JellyPoi 24 product page, located at <https://ignispixel.com/product/ignis-pixel-jellypoi-24-basic>

Technical characteristics

- Resolution: Poi: 24 pixels (72 LEDs); Knobs: 5 pixels (15 LEDs)
- Rendering speed: 2500 rows/second
- Total length of poi: 17 cm (6.7")
- Length of LED part: 17 cm (6.7")
- Weight: Adjustable 115-195 g (4-6.9 oz.)
- Working time: 9h average; 40 min full white; up to 40h low brightness
- Number of colors: 16,7 million (Color depth 24 bit)
- Battery capacity: from 2600 mAh to 3500 mAh**

Powerful battery



Big battery with capacity 2600 mAh provides 2 times longer light time as compared to JellyPoi.
 Average working time - 6 hours
 In full white mode - 1 hour
 On low brightness - up to 15 hours.

JellyPoi24 feature set			
	Basic	Smart	Ultimate
Cord	Black braided nylon cord 7mm	Soft braided non-springy white cord 8mm	Soft braided non-springy white cord 8mm
Upload pictures support via application	Yes	Yes	Yes
Training statistics support via application	No	Yes	Yes
Image stabilization option	No	Yes	Yes
Swivel inside the knob	No	Steel ball bearing	Corrode resistant ceramic bearing
Battery capacity	2600 mAh	2600 mAh	3500 mAh
Average light time on 50% brightness	~9 h	~9 h	~12 h
Price for set of 2 pois (contact with us to order 1 or 3 pois)	US \$377 US \$449 -10%	US \$456 US \$519 -12%	US \$526 US \$619 -15%

See, e.g., Ignis JellyPoi 24 & Pixel Knobs product page, located at <https://ignispixel.com/product/ignis-pixel-jellypoi-24-with-knob>

Technical characteristics

- Resolution: 20 pixels (40 LEDs)
- Rendering speed: 2500 rows/second
- Total length of poi: 15 cm (5.9")
- Length of LED part: 15 cm (5.9")
- Weight: 52 g (1.83 oz.)
- Working time: 4h average; 27 min full white; up to 20h low brightness
- Number of colors: 16,7 million (Color depth 24 bit)
- Battery capacity: 750 mAh**

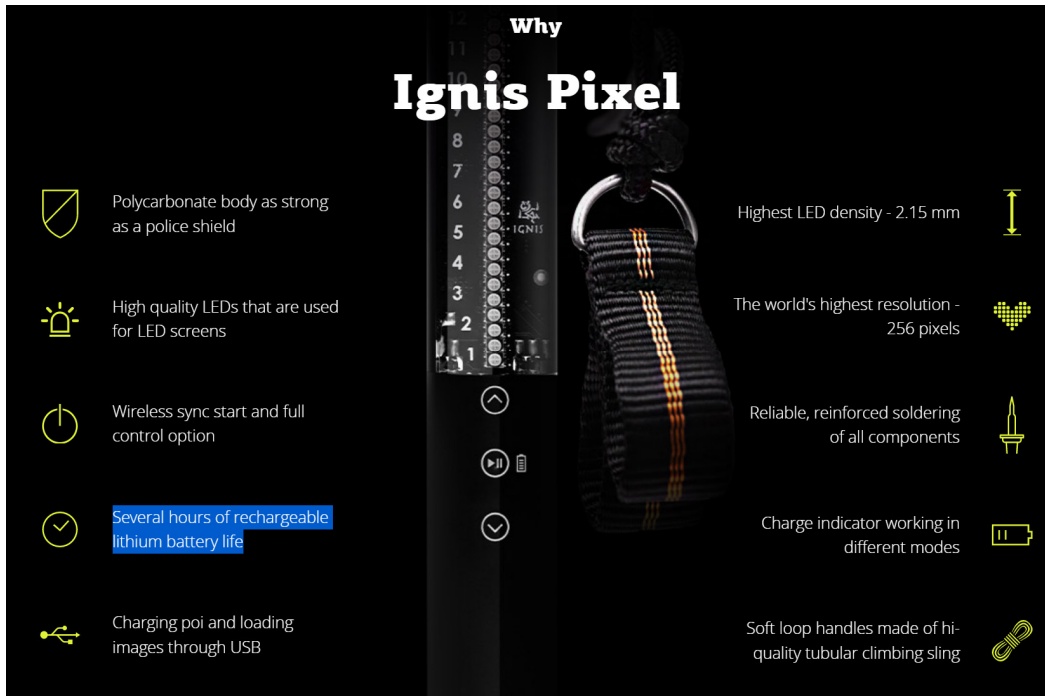

See, e.g., Ignis Stick 20 & Stick 20 Smart product page, located at <https://ignispixel.com/product/ignis-pixel-stick>

191. The Pixel system comprises an image represented by said data transferred from said computer to the controller displayed by said rotatable assembly during rotation of said rotatable assembly, said image displayed without bending the horizontal ground plane around said axis, including, for example, at least the Poi device creating a POV image based, *inter alia*, on the data received at the controller from the computer and via, *inter alia*, the controller selectively changing the illumination elements such that the image is created in a manner which does not distort the image around the axis about which the Poi device is being rotated:

Programming timeline modes (time-programmed sequence of pictures).

You can set the duration for each uploaded picture, thus creating a sequence of them, synchronized with the music. There are ten timeline custom sequences, T1-T10.

To configure the timeline:

1. Run Ignis Pixel Utility;
2. Open single pictures from files through menu **Add -> Image** or drag and drop files to the Image list into the left upper area of Ignis Pixel Utility;
3. Select images in Image list, drag and drop them to a timeline (T1-T10) to the lower area of Ignis Pixel Utility;
4. Now you see a sequence of pictures. You can change their order and duration by dragging them or their borders, like in video editors. Use Ctrl (Cmd for MacOS) button to change editing method Ripple edit/Rolling edit;
5. To adjust the timeline synchronously with music, add your music file through menu **Add -> Music** or drag and drop an MP3 file to the Music slot of Ignis Pixel Utility (lower area, just above the timelines);
6. Connect your digital poi to your computer with Micro-USB cables and press **Scan** button in the **Device list** (right area of Ignis Pixel Utility);
7. Click **"Upload all"** button – the process can take up to several minutes depending on the poi model and height-width ratios of the pictures.
8. When you change only a duration or an order of pictures in a timeline to save time, just tick the required timeline and click **"Upload Checked"** – the process will take just a few seconds.

Saving your project

The software allows you to save the project, and you can send your project by e-mail or USB flash to another computer. You do not need to send the original pictures of your project. They are contained within the project file.

See, e.g., Manual for Ignis Pixel Poi at page 4, located at https://ignispixel.com/files/upload/manual/Manual_Ignis_Pixel_v3_EN.pdf

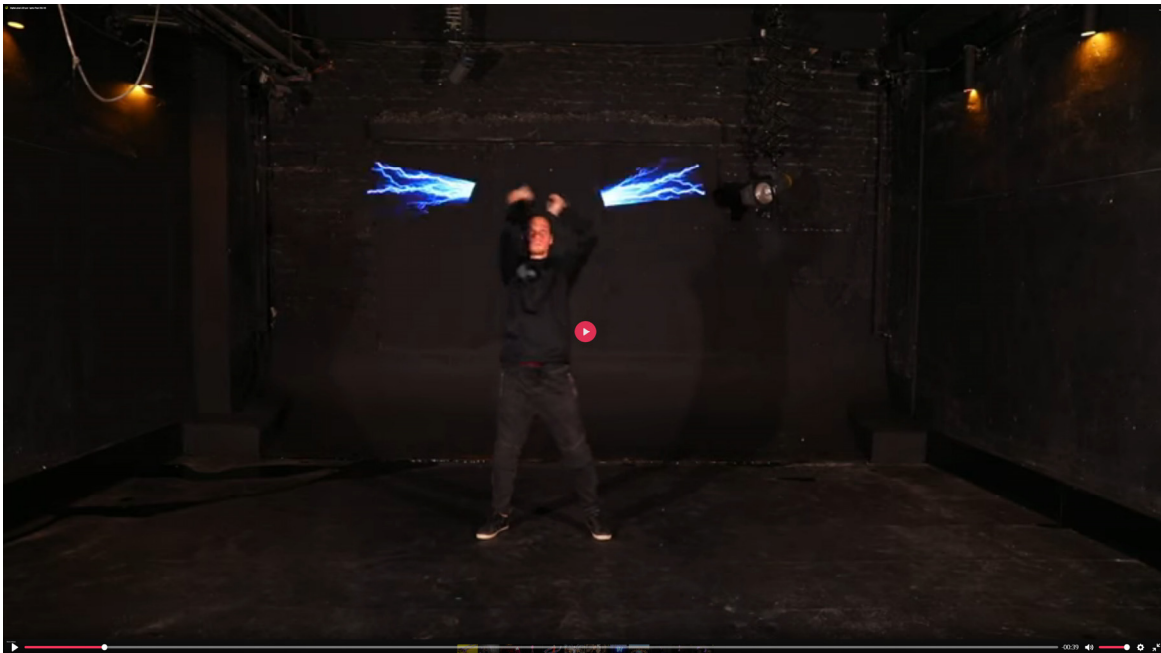
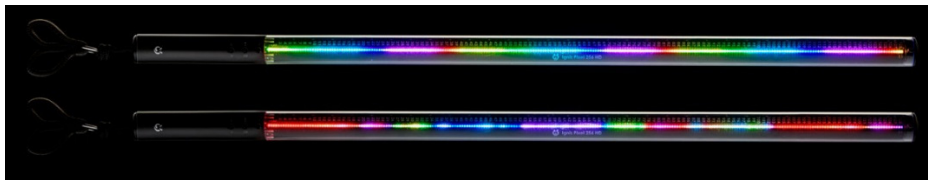

See, e.g., Ignis 256 HD product page, located at <https://ignispixel.com/product/ignis-pixel-poi->

[256-hd](#)



See, e.g., Ignis 200 HD product page, located at <https://ignispixel.com/product/ignis-pixel-poi-200-hd>

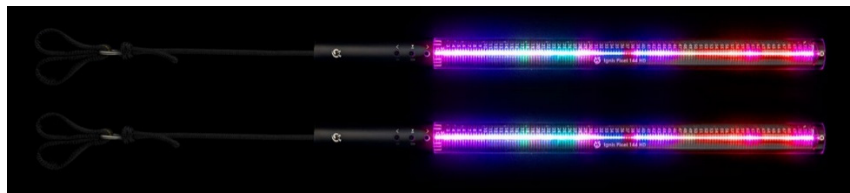



See, e.g., Ignis 144 HD product page, located at <https://ignispixel.com/product/ignis-pixel-poi-144-hd>

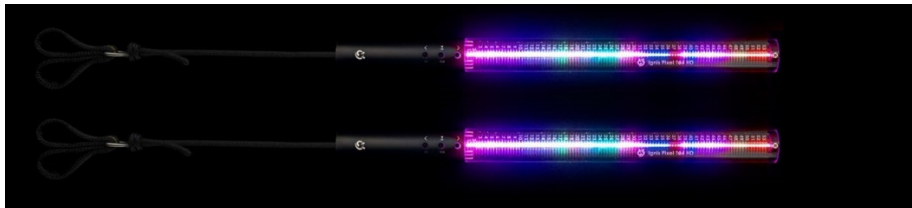

See, e.g., Ignis 104 HD product page, located at <https://ignispixel.com/product/ignis-pixel-poi-104-hd>



See, e.g., Ignis 80 HD product page, located at <https://ignispixel.com/product/ignis-pixel-poi-80-hd-tech>





See, e.g., Ignis 48 SD product page, located at [https://ignispixel.com/product/ignispixel-poi-48-lite](https://ignispixel.com/product/ignis-pixel-poi-48-lite)



See, e.g., Ignis 32 SD product page, located at <https://ignispixel.com/product/ignis-pixel-poi-32-tech>

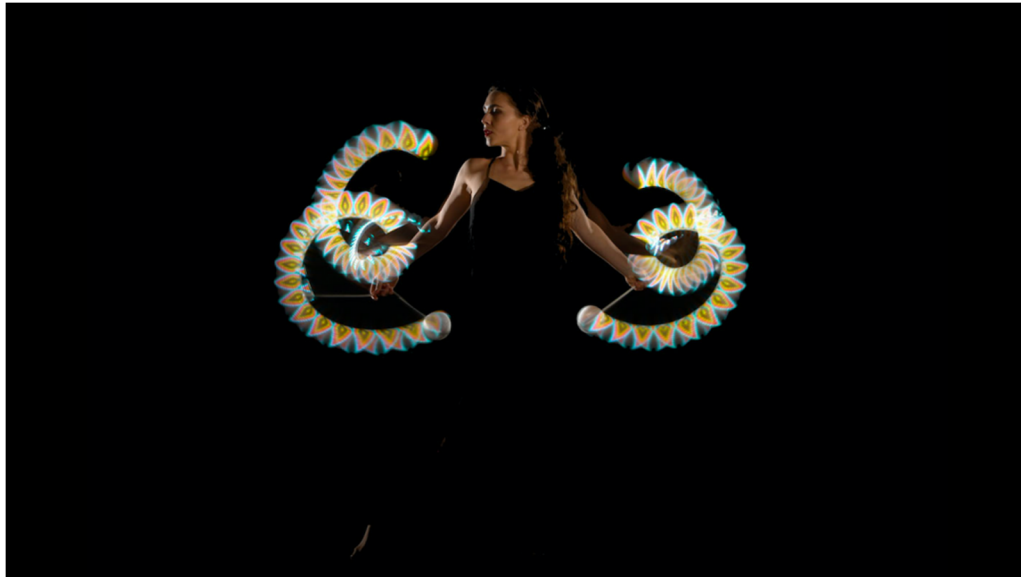
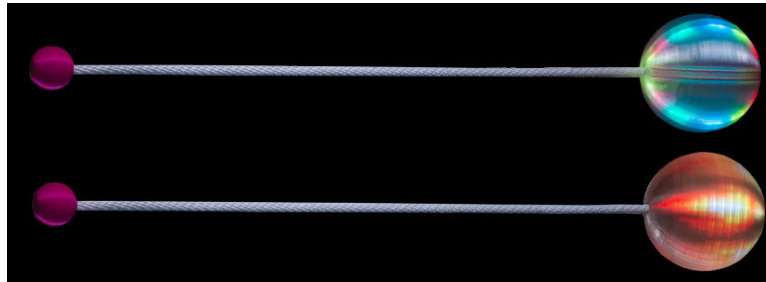

See, e.g., Ignis BubblePoi 16 product page, located at <https://ignispixel.com/product/bubble-led-poi-16-48-leds-basic>

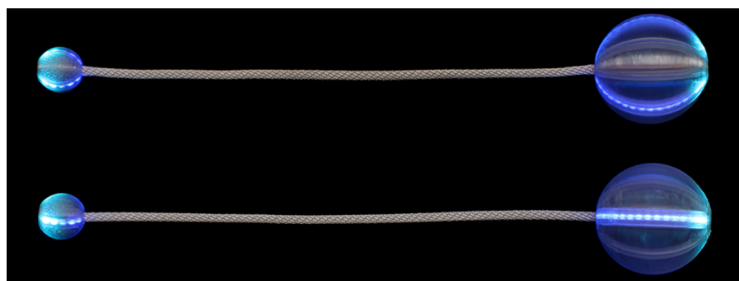



See, e.g., Ignis BubblePoi 16 & Pixel Knobs product page, located at <https://ignispixel.com/product/bubble-led-poi-16-48-leds-pixel-knob>

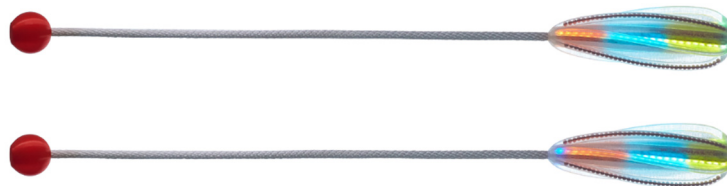

See, e.g., Ignis JellyPoi 24 product page, located at <https://ignispixel.com/product/ignis-pixel-jellypoi-24-basic>

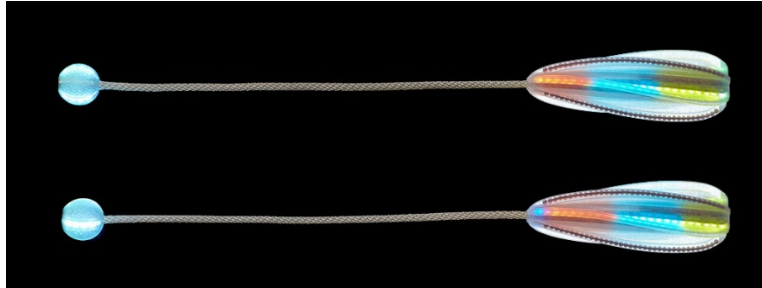

See, e.g., Ignis JellyPoi 24 & Pixel Knobs product page, located at <https://ignispixel.com/product/ignis-pixel-jellypoi-24-with-knob>

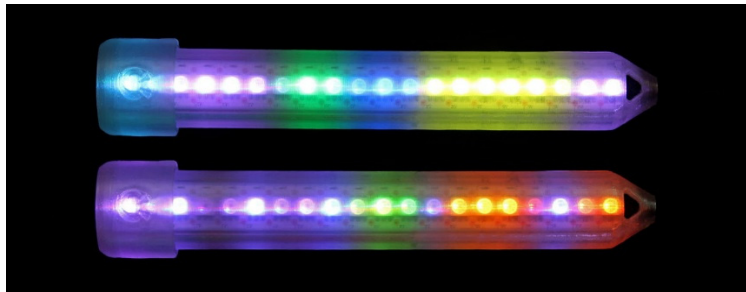

See, e.g., Ignis Stick 20 & Stick 20 Smart product page, located at <https://ignispixel.com/product/ignis-pixel-stick>

192. Upon information and belief, Defendant will have been on actual notice of the '214 Patent since, at the latest, the service of this Complaint, and, at the earliest, in February of 2017, or soon thereafter, when Plaintiff's founder, Mark, contacted Defendant's founder and requested a meeting regarding the technologies described in the Patents-in-Suit in relation to the implementation of such technologies in Defendant's devices at the time. At a minimum, Defendant has had at least constructive notice of the '214 Patent since at least its issuance, and by virtue of the fact that Defendant was made aware of Plaintiff's products embodying the '214 Patent which were marked at least by virtue of the listing of the Patents-in-Suit on Plaintiff's website.

193. Additionally, and/or in the alternative, at least since receiving notice of the '214 Patent, including, if necessary, from this suit and Complaint, Defendant has induced, and continues to induce, infringement of the '214 Patent in this Judicial District, and elsewhere, including in violation of 35 U.S.C. § 271(b), including by actions comprising actively inducing direct

infringement of the '214 Patent, including by knowingly and/or actively aiding and/or abetting infringement by customers and/or users, by and through at least instructing and encouraging the use of the Pixel systems, services, products, devices, and software noted herein, including the Pixel systems. Such aiding and/or abetting comprises providing software, products, user devices, and/or instructions regarding the use and/or operation of the Pixel systems, applications, servers, services, products, and devices in an infringing manner. Such induced infringement has occurred at least since Defendant became aware of the '214 Patent, at a minimum, as noted herein, and the knowledge and awareness that such actions by customers and/or other end users comprise infringement of the '214 Patent.

194. Additionally, and/or in the alternative, since receiving notice of the '214 Patent, including, if necessary, from this suit and Complaint, Defendant has contributed, and continues to contribute, to infringement of the '214 Patent in this Judicial District, and elsewhere, including in violation of 35 U.S.C. § 271(c), including by actions comprising contributing to the direct infringement of the '214 Patent, including via at least the use of said systems, services, products, devices, and software noted herein, including the use of the Pixel systems by customers and/or other end users. Such contributions necessarily comprise providing software, products, user devices, and/or instructions regarding the use and/or operation of the Pixel systems, applications, servers, services, products, and devices in an infringing manner, with the knowledge that such systems, applications, servers, services, products, and devices are especially made and/or especially adapted for use in an infringing manner and not a staple article and/or commodity of commerce suitable for substantial non-infringing use. Such contributory infringement has occurred since Defendant became aware of the '214 Patent, at a minimum, as noted herein, and the knowledge and awareness that such actions by customers and/or other end users comprise infringement of the '214 Patent.

195. The Pixel systems clearly meet the asserted claim limitations in their normal and expected usage. Upon information and belief, normal and expected usage of the Pixel systems by customers and/or end users satisfies the claim limitations for at least direct infringement. Further, at minimum, the provision of products, systems, and/or functionalities clearly capable of such infringing usage and/or provision of instructions/specifications for such infringing usage constitutes inducement of and/or contributing to directly infringing usage. Thus, by the time of trial, Defendant will have known and intended (at least since receiving such notice) that its continued actions would actively induce and/or contribute to the infringement of the asserted claims of the '214 Patent, including by customers and/or other end users.

196. Further, including as noted above, Defendant is being made aware of infringement of the '214 Patent through use of the Pixel systems at least via the infringement allegations set forth herein. Such direct, induced, and/or contributory infringement has been, and remains, clear, unmistakable, and inexcusable. Upon information and belief, Defendant knew, or should have known, of the clear, unmistakable, and inexcusable direct, induced, and/or contributory infringing conduct described herein at least since receiving notice of the '214 Patent. Thus, upon information and belief, Defendant has, at least since receiving notice of the '214 Patent, specifically intended to directly and/or indirectly infringe, including via direct infringement of customers and/or end users.

197. Plaintiff believes and contends that, at a minimum, Defendant's knowing and intentional post-notice and/or post-suit continuance of its unjustified, clear, and inexcusable infringement of the '214 Patent since receiving notice of its infringement of the '214 Patent, is necessarily willful, wanton, malicious, in bad-faith, deliberate, conscious, and wrongful, and it constitutes egregious conduct worthy of a finding of willful infringement. Accordingly, at least since receiving notice of this suit and/or the '214 Patent, Defendant has willfully infringed the '214

Patent.

COUNT II – INFRINGEMENT OF U.S. PATENT NO. 8,411,108

198. Plaintiff hereby refers to, and incorporates by reference, the allegations in the above paragraphs as if set forth fully herein.

199. Plaintiff is the assignee of the '108 Patent and has all substantial rights, title, and interest thereto, including the right and standing to sue, and recover damages, for past, present, and future infringement thereof, and to collect damages for any such past, present, or future infringement.

200. Claim 16 of the '108 Patent covers a “rotational display system including: a computer for storage and recall of data representing at least one visual image; a controller in electrical communication with the computer and operable to receive at least some of said data; a rotatable assembly for displaying an image represented by at least a portion of the data transferred from said computer to the controller, said rotatable assembly including an illuminating assembly, said illuminating assembly being operably connected to said controller, said illuminating assembly including at least one illuminating element, said rotatable assembly being constructed and arranged for attachment to a support for rotation about an axis; a power delivery means for providing power to said rotatable assembly; and an image represented by said data transferred from said computer to the controller displayed by said rotatable assembly during rotation of said rotatable assembly, said image displayed without bending the horizontal ground plane around said axis.”

201. Defendant has infringed, is now infringing, and continues to infringe, the '108 Patent, including at least claim 16, in this Judicial District, and elsewhere, in violation of 35 U.S.C. § 271 through actions comprising the making, using, offering for sale, selling, importing, and/or practicing, without authority from Plaintiff, systems for a rotational display system for displaying both cylindrical and planar type displays in a single apparatus and/or providing a rotational display

system which shows pre-defined and/or user-selected images, text, and/or video on a rotating display device (such as a vehicle wheel, rotating toy, helicopter blade, etc.), including via, *inter alia*, integrating multiple unique lighting technologies (including, *e.g.*, a rotatable assembly comprising at least one lighting assembly), computer systems, controller systems, switching systems, mounting and support systems, information delivery systems, and power supply systems (including, *e.g.*, power supply control mechanism) to display information on a rotating plane of the rotating display device, including via mapping the image to corresponding mathematical coordinates and toggling illuminating elements to create a POV image, including at least via Defendant's Pixel systems, including as claimed in the '214 asserted claims. On information and belief, Defendant provides the claimed systems with, and via, at least its Poi devices and systems, including at least Defendant's 256 HD, 200 HD, 144 HD, 104 HD, 80 HD, 80 SD, 48 HD, 32 SD, Juggling Club 72 HD, Juggling Club 48 SD, Diabolo Sticks 24, Hula Hoop SD, Hula Hoop HD, RG Clubs SD, RG Clubs HD, Dragon 80 HD, Dragon 48 SD, Dragon 32 SD, Buugeng 80, Doublestaff 80 HD, 80L SD, 200L HD, 256L HD, 80N HD, 48N SD, 32N SD, Fans 36, and Jump Rope HD devices, including at least in combination with Defendant's other services, devices, and systems, including Defendant's software related thereto, including, without limitation, at least Defendant's Ignis Pixel Utility Application (including at least the Ignis Pixel Utility Windows Application and/or Ignis Pixel Utility MacOS Application). Further, including at least to the extent Defendant provides and/or supplies hardware, applications, software, and/or services, including applications, software, and/or services running on a user's computer and/or other device, the infringement of users that occurs in connection with Defendant's hardware, applications, software, and/or services occurs under the direction or control of Defendant.

202. Without limitation, and, for example, the infringing instrumentality comprising the Pixel systems comprise a rotational display system including: a computer for storage and recall of

data representing at least one visual image; a controller in electrical communication with the computer and operable to receive at least some of said data; a rotatable assembly for displaying an image represented by at least a portion of the data transferred from said computer to the controller, said rotatable assembly including an illuminating assembly, said illuminating assembly being operably connected to said controller, said illuminating assembly including at least one illuminating element, said rotatable assembly being constructed and arranged for attachment to a support for rotation about an axis; a power delivery means for providing power to said rotatable assembly; and an image represented by said data transferred from said computer to the controller displayed by said rotatable assembly during rotation of said rotatable assembly, said image displayed without bending the horizontal ground plane around said axis.

203. Further, the Pixel system comprises systems which comprise a rotational display system, including a rotatable assembly comprising at least one illumination device, a computing device and controller, each comprising electrical communication technology, including USB data technologies, which permit communication with the rotatable assembly, including in order for image data stored on the computer to be transmitted to the rotatable assembly, including via the controller, so that the rotatable assembly can, *inter alia*, power the illumination devices via a power source, rotate about an axis, and display an image transferred to the rotatable assembly while the rotatable assembly is rotated about the axis, including without bending the horizontal ground plane relative to the image and/or without otherwise warping and/or distorting the image.

204. For example, including as exemplified by Defendant's Poi devices, the Pixel system permits, *inter alia*, a rotational display system to show and/or display both cylindrical and planar type displays in a single apparatus and/or a pre-defined and/or user-selected images, text, and/or video on a rotating display device (such as a vehicle wheel, rotating toy, helicopter blade, etc.), including via, *inter alia*, integrating multiple unique lighting technologies (including, *e.g.*, a

rotatable assembly comprising at least one lighting assembly), computer systems, controller systems, switching systems, mounting and support systems, information delivery systems, and power supply systems (including, *e.g.*, power supply control mechanism) to display information on a rotating plane of the rotating display device, including via mapping the image to corresponding mathematical coordinates and toggling illuminating elements to create a POV image:

Programming timeline modes (time-programmed sequence of pictures).

You can set the duration for each uploaded picture, thus creating a sequence of them, synchronized with the music. There are ten timeline custom sequences, T1-T10.

To configure the timeline:

1. Run Ignis Pixel Utility;
2. Open single pictures from files through menu **Add -> Image** or drag and drop files to the Image list into the left upper area of Ignis Pixel Utility;
3. Select images in Image list, drag and drop them to a timeline (T1-T10) to the lower area of Ignis Pixel Utility;
4. Now you see a sequence of pictures. You can change their order and duration by dragging them or their borders, like in video editors. Use Ctrl (Cmd for MacOS) button to change editing method Ripple edit/Rolling edit;
5. To adjust the timeline synchronously with music, add your music file through menu **Add -> Music** or drag and drop an MP3 file to the Music slot of Ignis Pixel Utility (lower area, just above the timelines);
6. Connect your digital poi to your computer with Micro-USB cables and press **Scan** button in the **Device list** (right area of Ignis Pixel Utility);
7. Click "**Upload all**" button – the process can take up to several minutes depending on the poi model and height-width ratios of the pictures.
8. When you change only a duration or an order of pictures in a timeline to save time, just tick the required timeline and click "**Upload Checked**" – the process will take just a few seconds.

Saving your project

The software allows you to save the project, and you can send your project by e-mail or USB flash to another computer. You do not need to send the original pictures of your project. They are contained within the project file.

See, *e.g.*, Manual for Ignis Pixel Poi at page 4, located at https://ignispixel.com/files/upload/manual/Manual_Ignis_Pixel_v3_EN.pdf

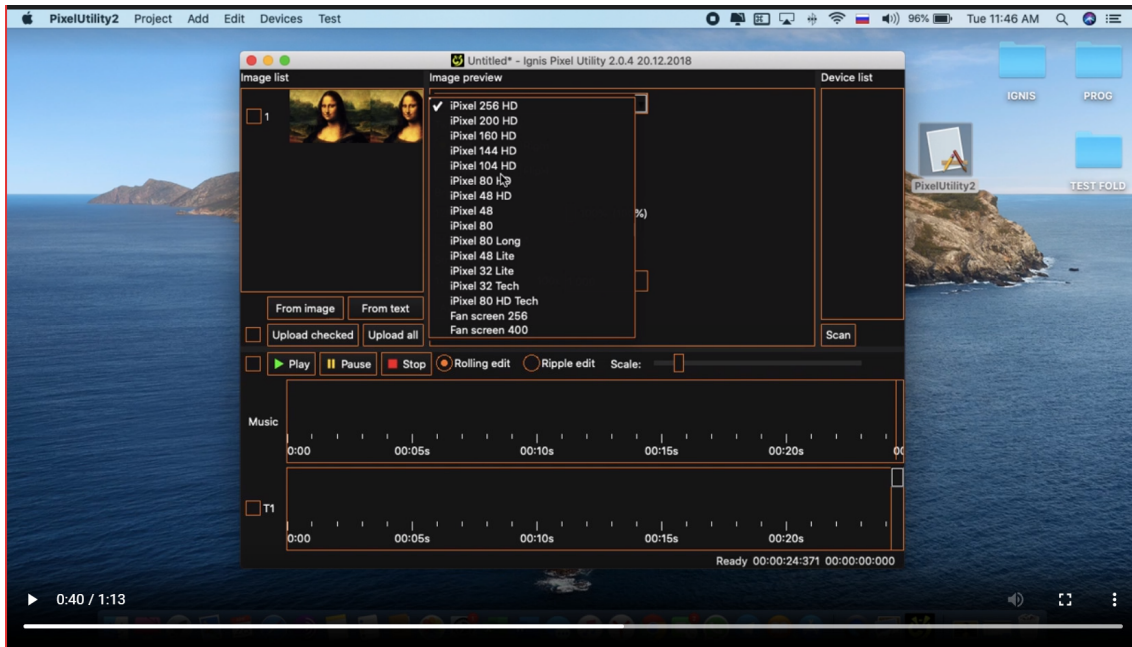

See, e.g., Installation Instructions for Ignis Pixel Utility 2 Application at timestamp 0:40, located at <https://ipxl.nyc3.cdn.digitaloceanspaces.com/videos/ignis-utility-macos-install-720p.mp4>

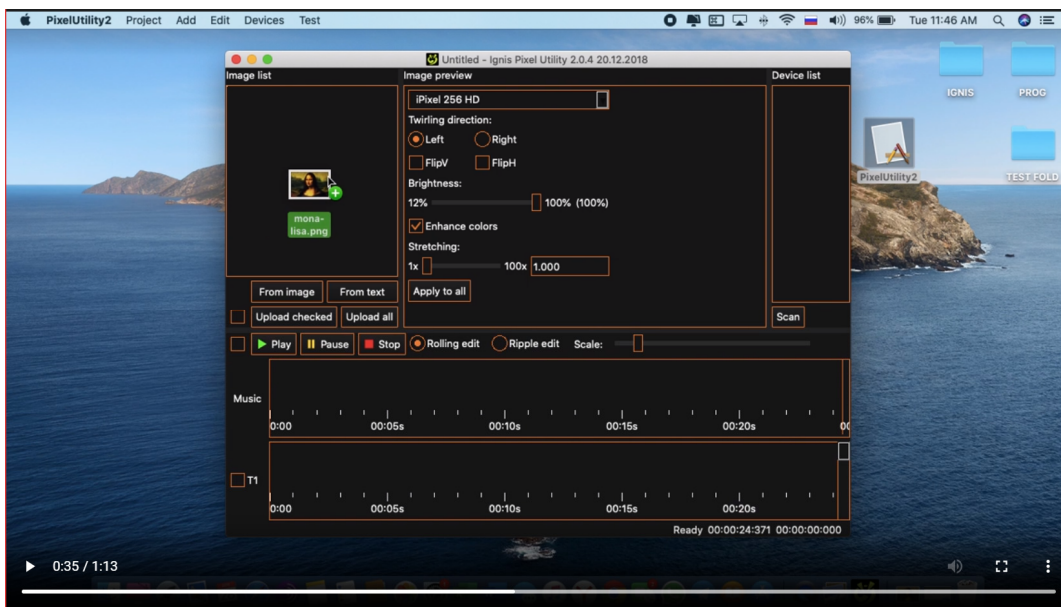

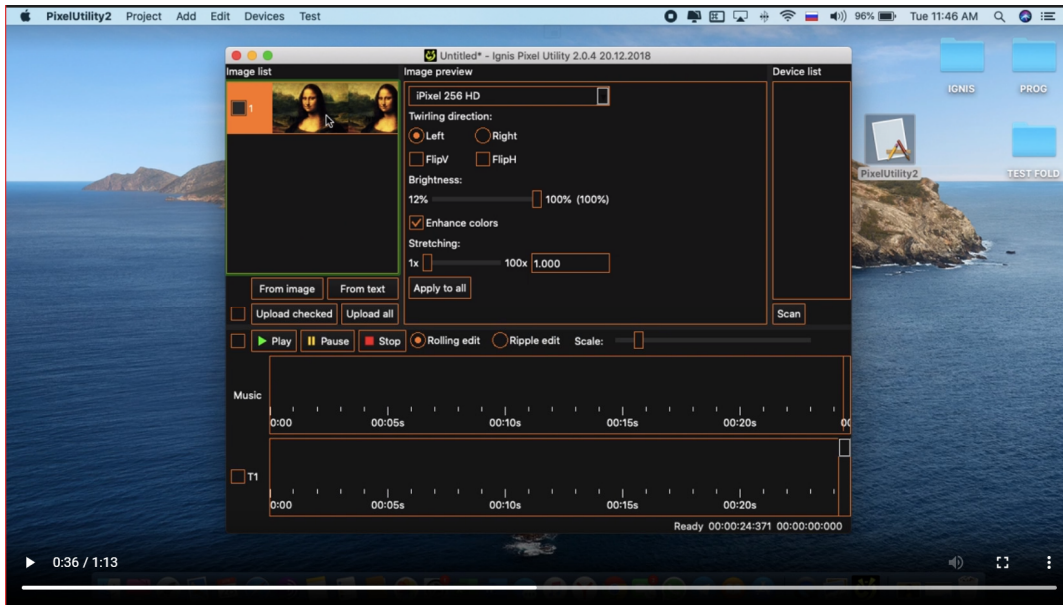

See, e.g., Installation Instructions for Ignis Pixel Utility 2 Application at timestamp 0:35-0:36, located at <https://ipxl.nyc3.cdn.digitaloceanspaces.com/videos/ignis-utility-macos-install-720p.mp4>

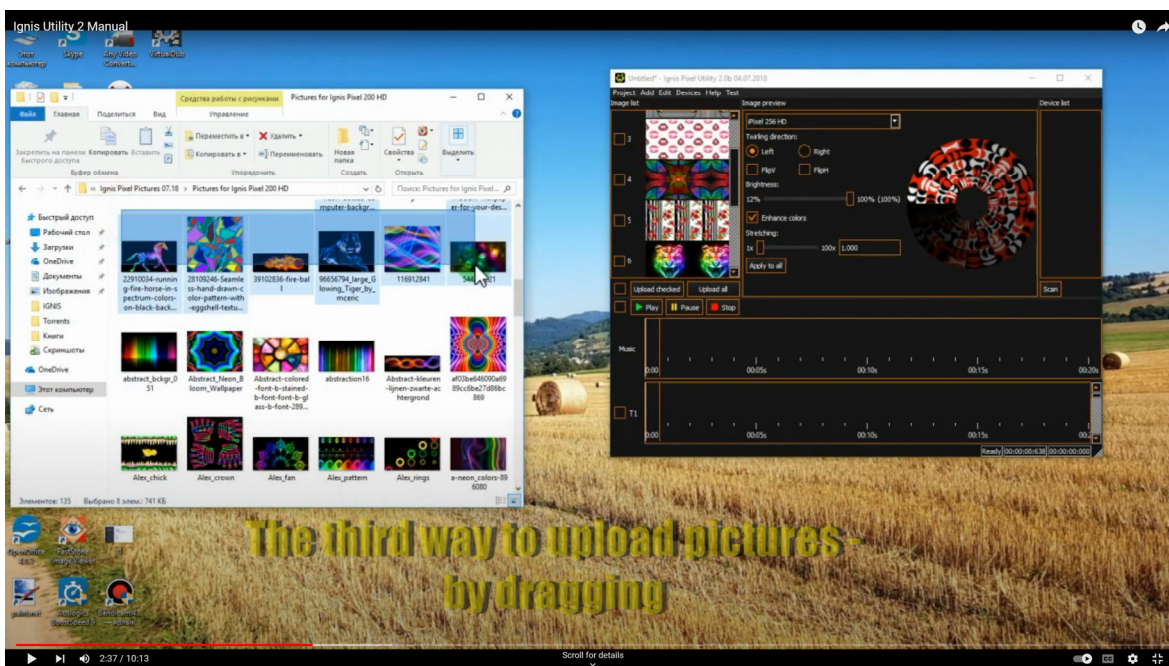

See, e.g., YouTube video by Igor Ignis titled “Ignis Utility 2 Manual” at timestamp 2:36-2:38, located at <https://www.youtube.com/watch?v=FUdYDPsoVnQ>



See, e.g., Ignis 256 HD product page, located at <https://ignispixel.com/product/ignis-pixel-poi-256-hd>

205. The Pixel system comprises a computer. For example, the Pixel system includes at least an attached and/or connected computing device (e.g., a laptop, desktop, mobile phone, tablet, etc.) or another Poi Device:

Programming timeline modes (time-programmed sequence of pictures).

You can set the duration for each uploaded picture, thus creating a sequence of them, synchronized with the music. There are ten timeline custom sequences, T1-T10.

To configure the timeline:

1. Run Ignis Pixel Utility;
2. Open single pictures from files through menu **Add -> Image** or drag and drop files to the Image list into the left upper area of Ignis Pixel Utility;
3. Select images in Image list, drag and drop them to a timeline (T1-T10) to the lower area of Ignis Pixel Utility;
4. Now you see a sequence of pictures. You can change their order and duration by dragging them or their borders, like in video editors. Use Ctrl (Cmd for MacOS) button to change editing method Ripple edit/Rolling edit;
5. To adjust the timeline synchronously with music, add your music file through menu **Add -> Music** or drag and drop an MP3 file to the Music slot of Ignis Pixel Utility (lower area, just above the timelines);
6. Connect your digital poi to your computer with Micro-USB cables and press **Scan** button in the **Device list** (right area of Ignis Pixel Utility);
7. Click **"Upload all"** button – the process can take up to several minutes depending on the poi model and height-width ratios of the pictures.
8. When you change only a duration or an order of pictures in a timeline to save time, just tick the required timeline and click **"Upload Checked"** – the process will take just a few seconds.

Saving your project

The software allows you to save the project, and you can send your project by e-mail or USB flash to another computer. You do not need to send the original pictures of your project. They are contained within the project file.

See, e.g., Manual for Ignis Pixel Poi at page 4, located at https://ignispixel.com/files/upload/manual/Manual_Ignis_Pixel_v3_EN.pdf

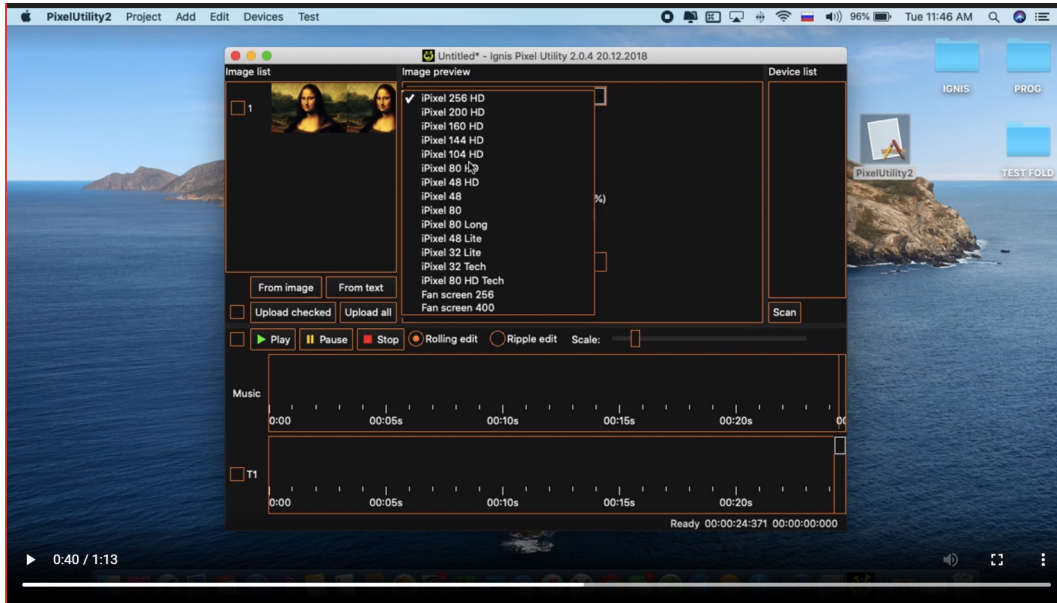

See, e.g., Installation Instructions for Ignis Pixel Utility 2 Application at timestamp 0:40, located at <https://ipxl.nyc3.cdn.digitaloceanspaces.com/videos/ignis-utility-macos-install-720p.mp4>

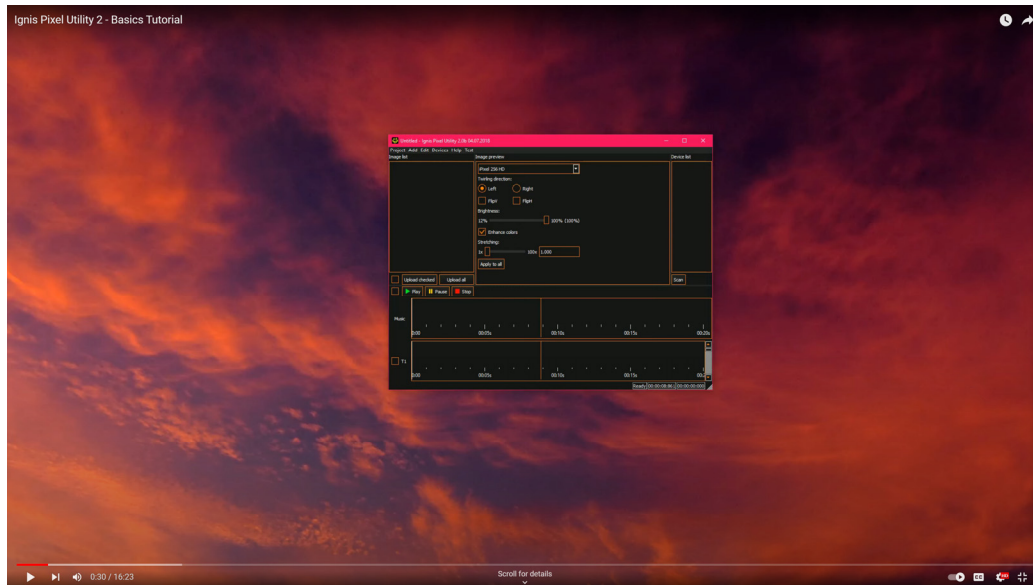

See, e.g., YouTube video by Devmode titled “Ignis Pixel Utility 2 – Basic Tutorial” at timestamp 0:30, located at <https://www.youtube.com/watch?v=xFFPDyKbD4Y>

206. The Pixel system comprises the computer being for storage of data representing at least one visual image. For example, the Pixel system includes at least a computing device having Defendant’s software installed thereon, permitting the user to, *inter alia*, store images as picture or other data files, including images for use with an Ignis Poi Device:

Programming timeline modes (time-programmed sequence of pictures).

You can set the duration for each uploaded picture, thus creating a sequence of them, synchronized with the music. There are ten timeline custom sequences, T1-T10.

To configure the timeline:

1. Run Ignis Pixel Utility;
2. Open single pictures from files through menu **Add -> Image** or drag and drop files to the Image list into the left upper area of Ignis Pixel Utility;
3. Select images in Image list, drag and drop them to a timeline (T1-T10) to the lower area of Ignis Pixel Utility;
4. Now you see a sequence of pictures. You can change their order and duration by dragging them or their borders, like in video editors. Use Ctrl (Cmd for MacOS) button to change editing method Ripple edit/Rolling edit;
5. To adjust the timeline synchronously with music, add your music file through menu **Add -> Music** or drag and drop an MP3 file to the Music slot of Ignis Pixel Utility (lower area, just above the timelines);
6. Connect your digital poi to your computer with Micro-USB cables and press **Scan** button in the **Device list** (right area of Ignis Pixel Utility);
7. Click "**Upload all**" button – the process can take up to several minutes depending on the poi model and height-width ratios of the pictures.
8. When you change only a duration or an order of pictures in a timeline to save time, just tick the required timeline and click "**Upload Checked**" – the process will take just a few seconds.

See, e.g., Manual for Ignis Pixel Poi at page 4, located at https://ignispixel.com/files/upload/manual/Manual_Ignis_Pixel_v3_EN.pdf

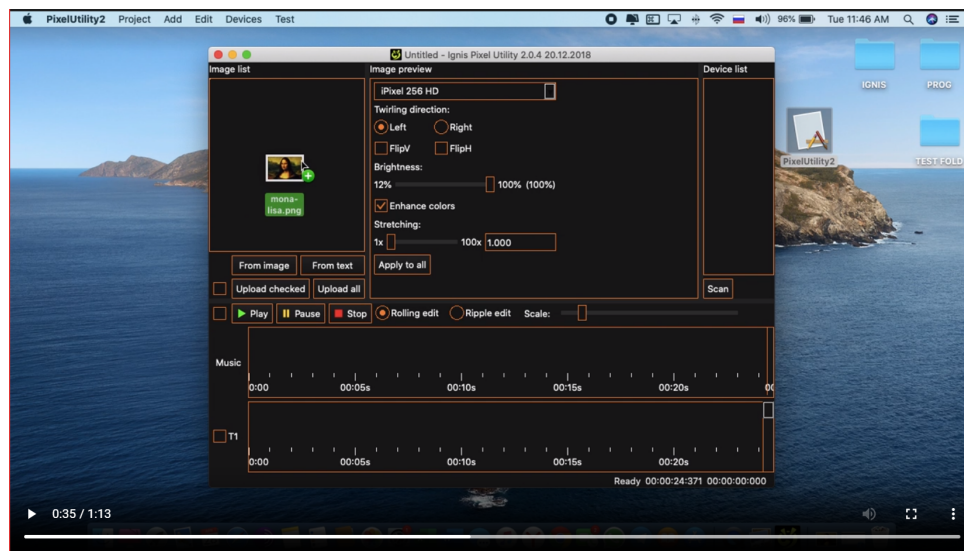

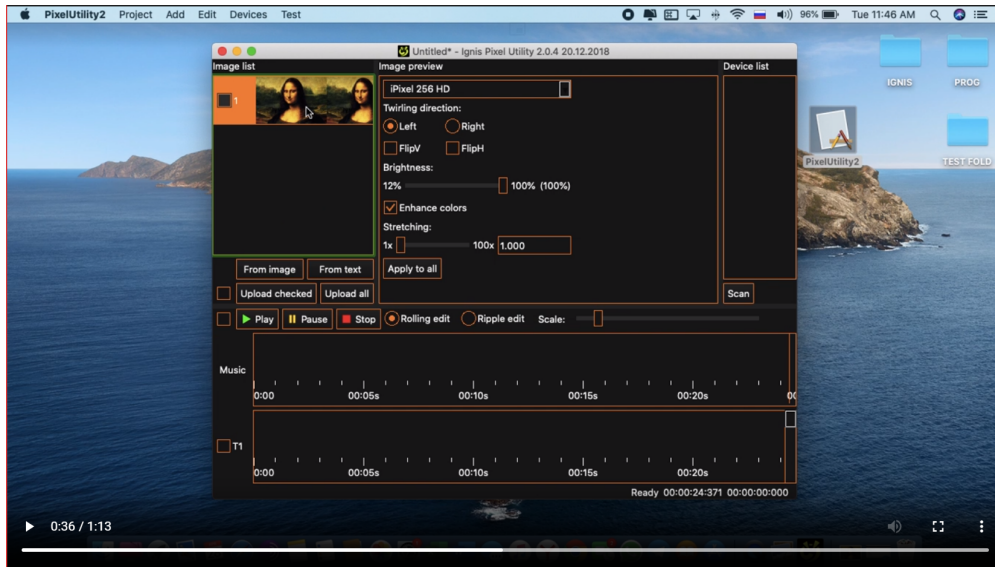

See, e.g., Installation Instructions for Ignis Pixel Utility 2 Application at timestamp 0:35-0:36, located at <https://ipxl.nyc3.cdn.digitaloceanspaces.com/videos/ignis-utility-macos-install-720p.mp4>

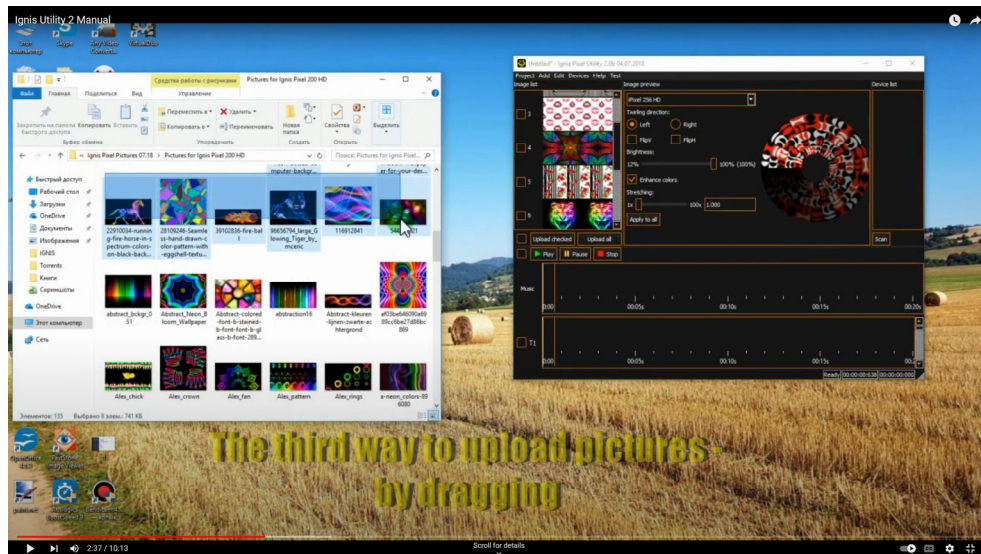

See, e.g., YouTube video by Igor Ignis titled “Ignis Utility 2 Manual” at timestamp 2:36-2:38, located at <https://www.youtube.com/watch?v=FUDYDPsoVnQ>

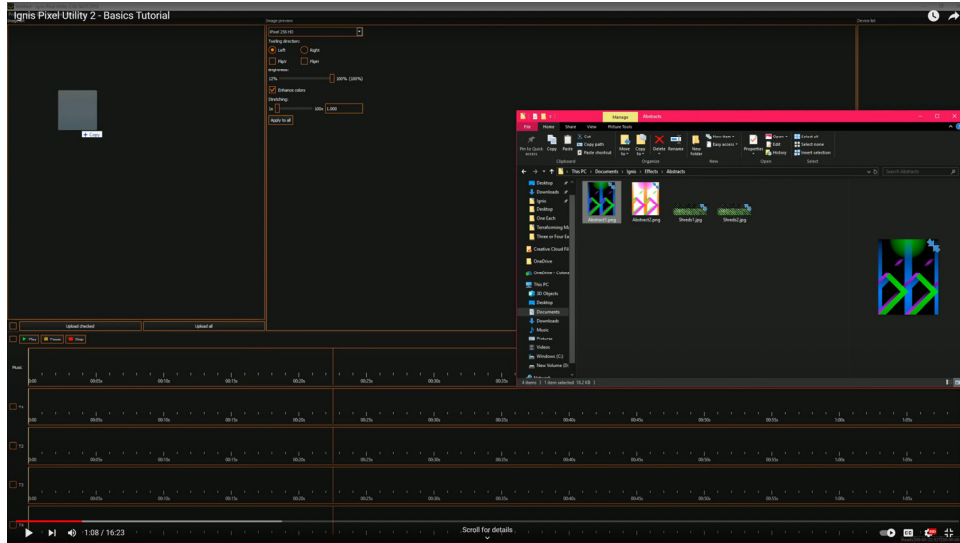

See, e.g., YouTube video by Devmode titled “Ignis Pixel Utility 2 – Basic Tutorial” at timestamp 1:08-1:10, located at <https://www.youtube.com/watch?v=xFFPDyKbD4Y>

207. The Pixel system comprises the computer being for recall of data representing at least one visual image. For example, the Pixel system includes at least a computing device having Defendant’s software installed thereon, permitting the user to, *inter alia*, retrieve and view images stored as picture or other data files, including images for use with an Ignis Poi Device:

Programming timeline modes (time-programmed sequence of pictures).

You can set the duration for each uploaded picture, thus creating a sequence of them, synchronized with the music. There are ten timeline custom sequences, T1-T10.

To configure the timeline:

1. Run Ignis Pixel Utility;
2. Open single pictures from files through menu **Add -> Image** or drag and drop files to the Image list into the left upper area of Ignis Pixel Utility;
3. Select images in Image list, drag and drop them to a timeline (T1-T10) to the lower area of Ignis Pixel Utility;
4. Now you see a sequence of pictures. You can change their order and duration by dragging them or their borders, like in video editors. Use Ctrl (Cmd for MacOS) button to change editing method Ripple edit/Rolling edit;
5. To adjust the timeline synchronously with music, add your music file through menu **Add -> Music** or drag and drop an MP3 file to the Music slot of Ignis Pixel Utility (lower area, just above the timelines);
6. Connect your digital poi to your computer with Micro-USB cables and press **Scan** button in the **Device list** (right area of Ignis Pixel Utility);
7. Click "**Upload all**" button – the process can take up to several minutes depending on the poi model and height-width ratios of the pictures.
8. When you change only a duration or an order of pictures in a timeline to save time, just tick the required timeline and click "**Upload Checked**" – the process will take just a few seconds.

See, e.g., Manual for Ignis Pixel Poi at page 4, located at https://ignispixel.com/files/upload/manual/Manual_Ignis_Pixel_v3_EN.pdf

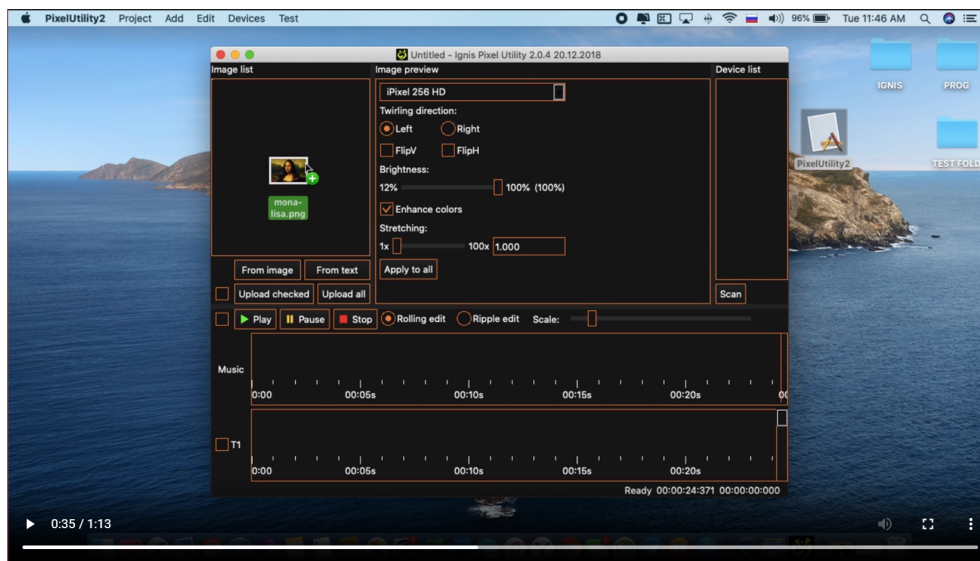

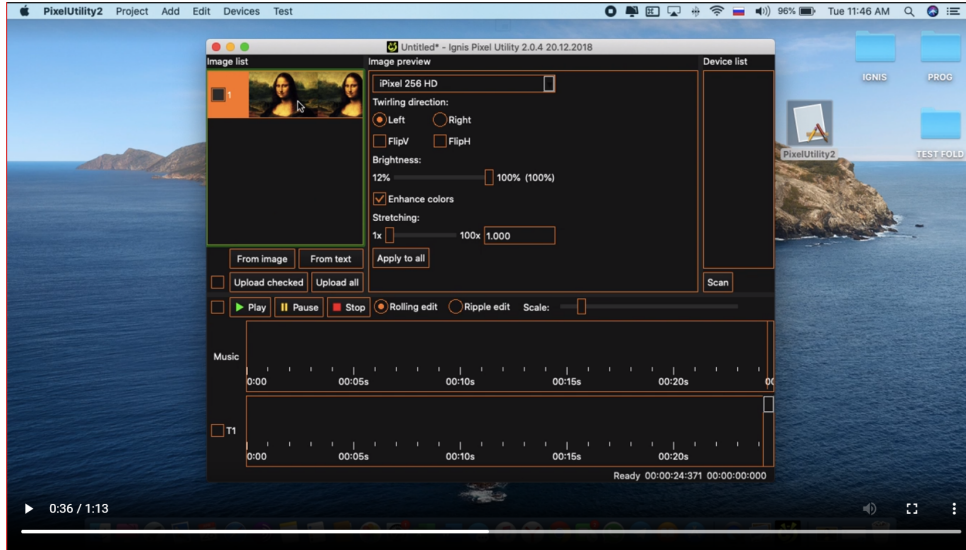

See, e.g., Installation Instructions for Ignis Pixel Utility 2 Application at timestamp 0:35-0:36, located at <https://ipxl.nyc3.cdn.digitaloceanspaces.com/videos/ignis-utility-macos-install-720p.mp4>

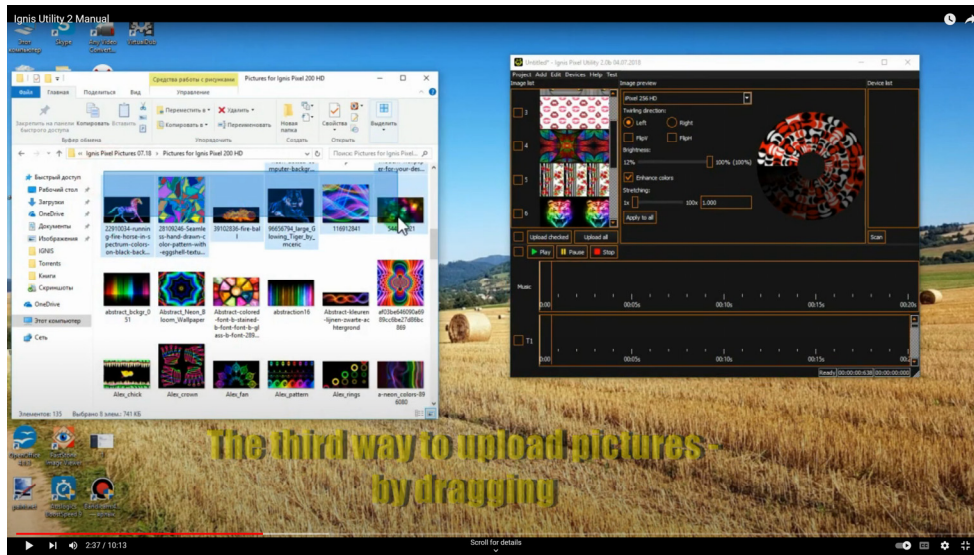

See, e.g., YouTube video by Igor Ignis titled “Ignis Utility 2 Manual” at timestamp 2:36-2:38, located at <https://www.youtube.com/watch?v=FUDYDPsoVnQ>

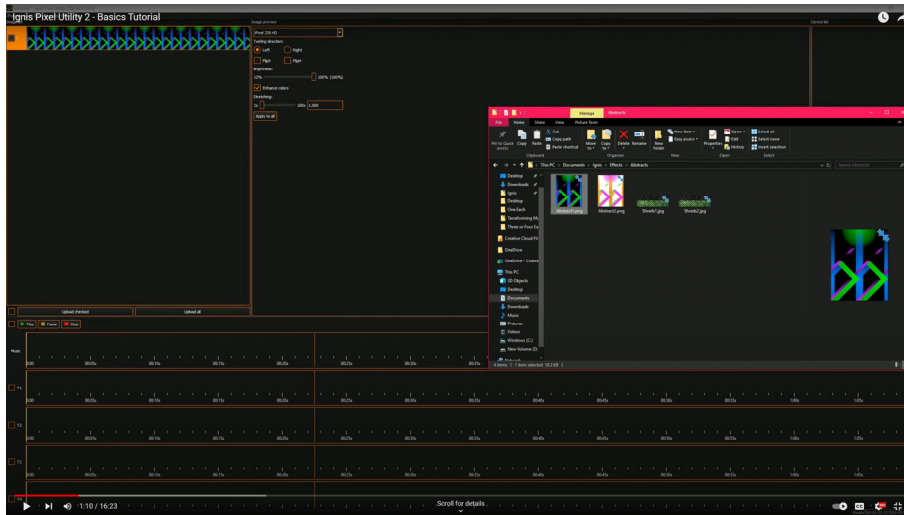
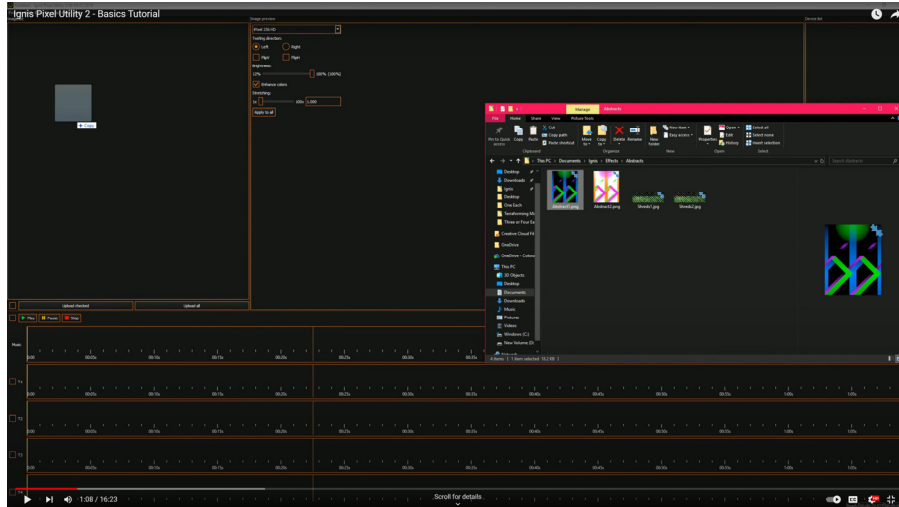

See, e.g., YouTube video by Devmode titled “Ignis Pixel Utility 2 – Basic Tutorial” at timestamp 1:08-1:10, located at <https://www.youtube.com/watch?v=xFFPDyKbD4Y>

208. The Pixel system comprises a controller in electrical communication with the computer. For example, the Pixel system includes at least hardware, software, and/or firmware, including, *inter alia*, circuitry and/or sensor devices, within the Poi device comprising electrical connectivity permitting the Pixel system to, *inter alia*, connect to, and communicate with, the user’s computing device over said electrical connectivity protocol (e.g., USB):

Upload texts, emoji, logos and simple graphic! Relatively low resolution is offset by the brightness — Ignis Pixel 32 Tech are noticeable at night, lamplight and even in daylight. These affordable pixel LED pois are fully programmable and have all main functions of professional sets that can help to make your show spectacular and impressive. You can synchronize your performance scenario with music and adjust up to 10 timelines in the convenient software for Windows and MacOS. Start your career with these simple poi sticks and come back for some advanced models in future.

The poi 32 SD are equipped with Wireless Sync option that allows synchronizing the poi between each other and with other Ignis props. A perfect solution with many settings of group work to ensure sync work of props in big teams.

Software

Uploading pictures music, and visual editing timelines (sequences of uploaded pictures)

Software is compatible with Windows and MacOS

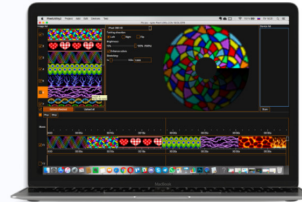

See, e.g., Ignis 32 SD product page, located at <https://ignispixel.com/product/ignis-pixel-poi-32-tech>

These pixel LED pois are fully programmable and have all main functions of more expensive professional sets. Upload texts, emoji, logos and graphic, synchronize your performance scenario with music, and adjust up to 10 timelines in the convenient software for Windows and MacOS. Ignis Pixel 48 Lite work up to 4 hours — this is quite enough to show the audience your skills and artistry.

The poi 48 HD are equipped with Wireless Sync option that allows synchronizing the poi between each other and with other Ignis props. A perfect solution with many settings of group work to ensure sync work of props in big teams.

Software

Uploading pictures music, and visual editing timelines (sequences of uploaded pictures)

Software is compatible with Windows and MacOS

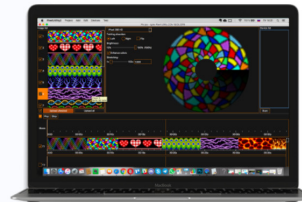

See, e.g., Ignis 48 SD product page, located at <https://ignispixel.com/product/ignis-pixel-poi-48-lite>

Resolution of 80 pixels allows to upload not only text, emoji, logos, and graphic, but also photos of people's faces. This will help to make your shows more custom and various. Ignis 80 Long also supports music synchronization and with the help of our software for Windows and MacOS you can adjust up to 10 timelines. As you can see, this LED poi set is just as good as PRO models.

The poi 80 SD are equipped with Wireless Sync option that allows synchronizing the poi between each other and with other Ignis props. A perfect solution with many settings of group work to ensure sync work of props in big teams.

Software

Uploading pictures music, and visual editing timelines (sequences of uploaded pictures)

Software is compatible with Windows and MacOS

DOWNLOAD

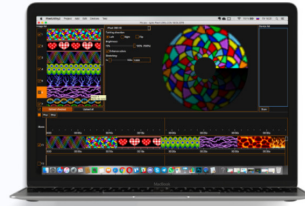

See, e.g., Ignis 80 SD product page, located at <https://ignispixel.com/product/ignis-pixel-poi-80>

Ignis 80 HD Tech is our flagship model for professional spinners. Ignis 80 HD Tech has the best balance between length, number of LEDs, and resolution on the market of pixel equipment. At first we made this model for such profiles as Tim Goddard (@timmehtek) from Australia, Yuta Imamura (@yutapoi) from Japan, Ben Drexler (@drexfactor) from the USA, Gustavo Ollitta (@gollitta) from Brazil, but decided that Ignis 80 HD Tech deserves attention of other professionals. Short length (6.7 inch) allows to do spirals, wraps, orbitals, hyperloops and even juggling them. And due to the high resolution of 80 pixels, you can upload to this LED poi set texts, emoji, logos, graphic and also photos with people's faces and small details. Work with programmable LED poi sticks in the user-friendly software compatible with Windows and Mac OS. If our world record in resolution doesn't make sense to you, than pay attention to the rendering speed — 3 000 rows per second!

To make technically advanced tricks such as hyperloops we supplied 80 HD Tech with bearing swivels. We also made them light (4.2 oz) and added all functions that could be useful for professionals: music synchronization, ability to adjust up to 10 timelines and wireless control option (not included in standard digital poi set).

The poi 80 HD are equipped with Wireless Sync option that allows synchronizing the poi between each other and with other Ignis props. A perfect solution with many settings of group work to ensure sync work of props in big teams.

Software

Uploading pictures music, and visual editing timelines (sequences of uploaded pictures)

Software is compatible with Windows and MacOS

DOWNLOAD

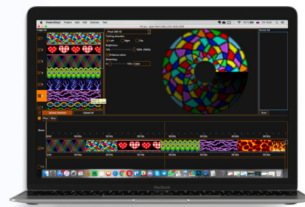

See, e.g., Ignis 80 HD product page, located at <https://ignispixel.com/product/ignis-pixel-poi-80-hd-tech>

LED poi Ignis 104 HD is shortest digital poi with high 104-pixel resolution. Length of poi is only 35 cm, which is suitable for performing technically advanced spinning with elements such as spirals, wraps and even orbitals. 104 LEDs mounted with pitch 2,1 mm to each other and allows you to draw in the air not only pictures but also photos with faces of people who are easily recognized by the audience!

No doubt with Ignis 104 HD your performance makes a sensation!

The poi are equipped with the following built-in features:

— Wireless Sync option – allows synchronizing the poi between each other and with other Ignis props. A perfect solution with many settings of group work to ensure sync work of props in big teams;

Software

Uploading pictures music, and visual editing timelines (sequences of uploaded pictures)

Software is compatible with Windows and MacOS

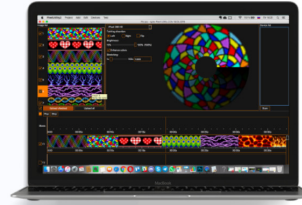

See, e.g., Ignis 104 HD product page, located at <https://ignispixel.com/product/ignis-pixel-poi-104-hd>

Ignis 144 HD are fully programmable poi. They have everything you need — music synchronisation, ability to adjust up to 10 timelines using software for Windows and MacOS, and wireless control option (not included in standard digital poi set).

The poi are equipped with the following built-in features:

— Wireless Sync option – allows synchronizing the poi between each other and with other Ignis props. A perfect solution with many settings of group work to ensure sync work of props in big teams;

Software

Uploading pictures music, and visual editing timelines (sequences of uploaded pictures)

Software is compatible with Windows and MacOS



See, e.g., Ignis 144 HD product page, located at <https://ignispixel.com/product/ignis-pixel-poi-144-hd>

This is the favorite model of Ignis Pixel CEO Grigoriy Zhuravlev and artists from big shows, such as Circus of Zapashny brothers and Cirque du Soleil. Ignis 200 HD are also suitable for ladies and people with relatively short height — the total length of this model is 21.7 inch. The resolution of 200 pixels coupled with high rendering speed (2600 rows per second) allows to upload text, logos, emoji, graphic and detailed photos.

We also changed LEDs in new generation of Ignis Pixel 200 HD. New tiny LEDs show perfect colors with improved yellow and orange tones, that makes pictures on pois sharper, more realistic, and colorful. Synchronize your shows with music, adjust up to 10 timelines and make more money with our pixel equipment.

The poi are equipped with the following built-in features:

— Wireless Sync option – allows synchronizing the poi between each other and with other Ignis props. A perfect solution with many settings of group work to ensure sync work of props in big teams;

Software

Uploading pictures music, and visual editing timelines (sequences of uploaded pictures)

Software is compatible with Windows and MacOS

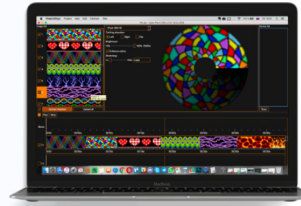

See, e.g., Ignis 200 HD product page, located at <https://ignispixel.com/product/ignis-pixel-poi-200-hd>

Upload logos, text, emoji, graphic, photos and don't bother — they will be recognisable at and in partial blackout. Synchronise your shows with music, adjust up to 10 timelines in our user-friendly software for Windows and Mac OS and make more money on your shows. We are sure, that these investments will pay off.

The poi are equipped with the following built-in features:

— Wireless Sync option – allows synchronizing the poi between each other and with other Ignis props. A perfect solution with many settings of group work to ensure sync work of props in big teams;

Software

Uploading pictures music, and visual editing timelines (sequences of uploaded pictures)

Software is compatible with Windows and MacOS

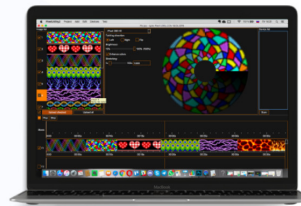

See, e.g., Ignis 256 HD product page, located at <https://ignispixel.com/product/ignis-pixel-poi-256-hd>

209. The Pixel system comprises the controller being operable to receive at least some of said data. For example, the Pixel system includes at least the controller, via the connection to the computer, receiving the images, and corresponding data, chosen by the user for display, including via the use of Defendant's software:

Upload texts, emoji, logos and simple graphic! Relatively low resolution is offset by the brightness — Ignis Pixel 32 Tech are noticeable at night, lamplight and even in daylight. These affordable pixel LED pois are fully programmable and have all main functions of professional sets that can help to make your show spectacular and impressive. You can synchronize your performance scenario with music and adjust up to 10 timelines in the convenient software for Windows and MacOS. Start your career with these simple poi sticks and come back for some advanced models in future.

The poi 32 SD are equipped with Wireless Sync option that allows synchronizing the poi between each other and with other Ignis props. A perfect solution with many settings of group work to ensure sync work of props in big teams.

Software

Uploading pictures music, and visual editing timelines (sequences of uploaded pictures)

Software is compatible with Windows and MacOS

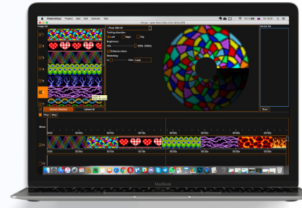

See, e.g., Ignis 32 SD product page, located at <https://ignispixel.com/product/ignis-pixel-poi-32-tech>

These pixel LED pois are fully programmable and have all main functions of more expensive professional sets. Upload texts, emoji, logos and graphic, synchronize your performance scenario with music, and adjust up to 10 timelines in the convenient software for Windows and MacOS. Ignis Pixel 48 Lite work up to 4 hours — this is quite enough to show the audience your skills and artistry.

The poi 48 HD are equipped with Wireless Sync option that allows synchronizing the poi between each other and with other Ignis props. A perfect solution with many settings of group work to ensure sync work of props in big teams.

Software

Uploading pictures music, and visual editing timelines (sequences of uploaded pictures)

Software is compatible with Windows and MacOS



See, e.g., Ignis 48 SD product page, located at <https://ignispixel.com/product/ignis-pixel-poi-48-lite>

Resolution of 80 pixels allows to upload not only text, emoji, logos, and graphic, but also photos of people's faces. This will help to make your shows more custom and various. Ignis 80 Long also supports music synchronization and with the help of our software for Windows and MacOS you can adjust up to 10 timelines. As you can see, this LED poi set is just as good as PRO models.

The poi 80 SD are equipped with Wireless Sync option that allows synchronizing the poi between each other and with other Ignis props. A perfect solution with many settings of group work to ensure sync work of props in big teams.

Software

Uploading pictures music, and visual editing timelines (sequences of uploaded pictures)

Software is compatible with Windows and MacOS



See, e.g., Ignis 80 SD product page, located at <https://ignispixel.com/product/ignis-pixel-poi-80>

Ignis 80 HD Tech is our flagship model for professional spinners. Ignis 80 HD Tech has the best balance between length, number of LEDs, and resolution on the market of pixel equipment. At first we made this model for such profiles as Tim Goddard (@timmehtek) from Australia, Yuta Imamura (@yutapoi) from Japan, Ben Drexler (@drexfactor) from the USA, Gustavo Ollitta (@gollitta) from Brazil, but decided that Ignis 80 HD Tech deserves attention of other professionals. Short length (6.7 inch) allows to do spirals, wraps, orbitals, hyperloops and even juggling them. And due to the high resolution of 80 pixels, you can upload to this LED poi set texts, emoji, logos, graphic and also photos with people's faces and small details. Work with programmable LED poi sticks in the user-friendly software compatible with Windows and Mac OS. If our world record in resolution doesn't make sense to you, than pay attention to the rendering speed — 3 000 rows per second!

To make technically advanced tricks such as hyperloops we supplied 80 HD Tech with bearing swivels. We also made them light (4.2 oz) and added all functions that could be useful for professionals: music synchronization, ability to adjust up to 10 timelines and wireless control option (not included in standard digital poi set).

The poi 80 HD are equipped with Wireless Sync option that allows synchronizing the poi between each other and with other Ignis props. A perfect solution with many settings of group work to ensure sync work of props in big teams.

Software

Uploading pictures music, and visual editing timelines (sequences of uploaded pictures)

Software is compatible with Windows and MacOS

DOWNLOAD

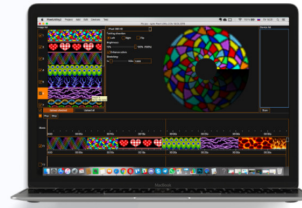

See, e.g., Ignis 80 HD product page, located at <https://ignispixel.com/product/ignis-pixel-poi-80-hd-tech>

LED poi Ignis 104 HD is shortest digital poi with high 104-pixel resolution. Length of poi is only 35 cm, which is suitable for performing technically advanced spinning with elements such as spirals, wraps and even orbitals. 104 LEDs mounted with pitch 2.1 mm to each other and allows you to draw in the air not only pictures but also photos with faces of people who are easily recognized by the audience!

No doubt with Ignis 104 HD your performance makes a sensation!

The poi are equipped with the following built-in features:

— Wireless Sync option – allows synchronizing the poi between each other and with other Ignis props. A perfect solution with many settings of group work to ensure sync work of props in big teams;

Software

Uploading pictures music, and visual editing timelines (sequences of uploaded pictures)

Software is compatible with Windows and MacOS

DOWNLOAD

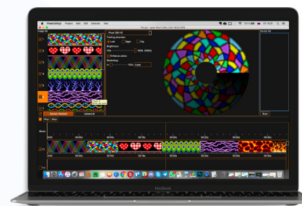

See, e.g., Ignis 104 HD product page, located at <https://ignispixel.com/product/ignis-pixel-poi-104-hd-tech>

104-hd

Ignis 144 HD are fully programmable poi. They have everything you need — music synchronisation, ability to adjust up to 10 timelines using software for Windows and MacOS, and wireless control option (not included in standard digital poi set).

The poi are equipped with the following built-in features:

— Wireless Sync option – allows synchronizing the poi between each other and with other Ignis props. A perfect solution with many settings of group work to ensure sync work of props in big teams;

Software

Uploading pictures music, and visual editing timelines (sequences of uploaded pictures)

Software is compatible with Windows and MacOS

DOWNLOAD

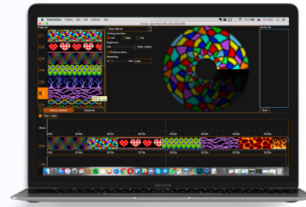

See, e.g., Ignis 144 HD product page, located at <https://ignispixel.com/product/ignis-pixel-poi-144-hd>

This is the favorite model of Ignis Pixel CEO Grigoriy Zhuravlev and artists from big shows, such as Circus of Zapashny brothers and Cirque du Soleil. Ignis 200 HD are also suitable for ladies and people with relatively short height — the total length of this model is 21.7 inch. The resolution of 200 pixels coupled with high rendering speed (2600 rows per second) allows to upload text, logos, emoji, graphic and detailed photos.

We also changed LEDs in new generation of Ignis Pixel 200 HD. New tiny LEDs show perfect colors with improved yellow and orange tones, that makes pictures on pois sharper, more realistic, and colorful. Synchronize your shows with music, adjust up to 10 timelines and make more money with our pixel equipment.

The poi are equipped with the following built-in features:

— Wireless Sync option – allows synchronizing the poi between each other and with other Ignis props. A perfect solution with many settings of group work to ensure sync work of props in big teams;

Software

Uploading pictures music, and visual editing timelines (sequences of uploaded pictures)

Software is compatible with Windows and MacOS

DOWNLOAD

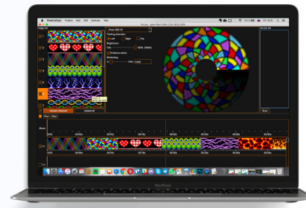

See, e.g., Ignis 200 HD product page, located at <https://ignispixel.com/product/ignis-pixel-poi-200-hd>

Upload logos, text, emoji, graphic, photos and don't bother — they will be recognisable at and in partial blackout. Synchronise your shows with music, adjust up to 10 timelines in our user-friendly software for Windows and Mac OS and make more money on your shows. We are sure, that these investments will pay off.

The poi are equipped with the following built-in features:

— Wireless Sync option – allows synchronizing the poi between each other and with other Ignis props. A perfect solution with many settings of group work to ensure sync work of props in big teams;

Software

Uploading pictures music, and visual editing timelines (sequences of uploaded pictures)

Software is compatible with Windows and MacOS

DOWNLOAD

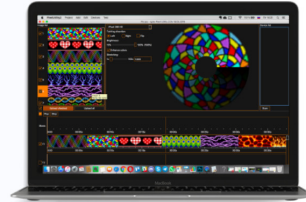

See, e.g., Ignis 256 HD product page, located at <https://ignispixel.com/product/ignis-pixel-poi-256-hd>

210. The Pixel system comprises a rotatable assembly for displaying an image represented by at least a portion of the data transferred from said computer to the controller. For example, the Pixel system includes at least a collection of lighting devices able to, *inter alia*, be rotated about an axis and selectively turn said lighting devices on and off to display the one or more images represented by the data chosen by the user and received from the computer (*see above re computer*) by the controller:

Programming timeline modes (time-programmed sequence of pictures).

You can set the duration for each uploaded picture, thus creating a sequence of them, synchronized with the music. There are ten timeline custom sequences, T1-T10.

To configure the timeline:

1. Run Ignis Pixel Utility;
2. Open single pictures from files through menu **Add -> Image** or drag and drop files to the Image list into the left upper area of Ignis Pixel Utility;
3. Select images in Image list, drag and drop them to a timeline (T1-T10) to the lower area of Ignis Pixel Utility;
4. Now you see a sequence of pictures. You can change their order and duration by dragging them or their borders, like in video editors. Use Ctrl (Cmd for MacOS) button to change editing method Ripple edit/Rolling edit;
5. To adjust the timeline synchronously with music, add your music file through menu **Add -> Music** or drag and drop an MP3 file to the Music slot of Ignis Pixel Utility (lower area, just above the timelines);
6. Connect your digital poi to your computer with Micro-USB cables and press **Scan** button in the **Device list** (right area of Ignis Pixel Utility);
7. Click "**Upload all**" button – the process can take up to several minutes depending on the poi model and height-width ratios of the pictures.
8. When you change only a duration or an order of pictures in a timeline to save time, just tick the required timeline and click "**Upload Checked**" – the process will take just a few seconds.

Saving your project

The software allows you to save the project, and you can send your project by e-mail or USB flash to another computer. You do not need to send the original pictures of your project. They are contained within the project file.

See, e.g., Manual for Ignis Pixel Poi at page 4, located at https://ignispixel.com/files/upload/manual/Manual_Ignis_Pixel_v3_EN.pdf

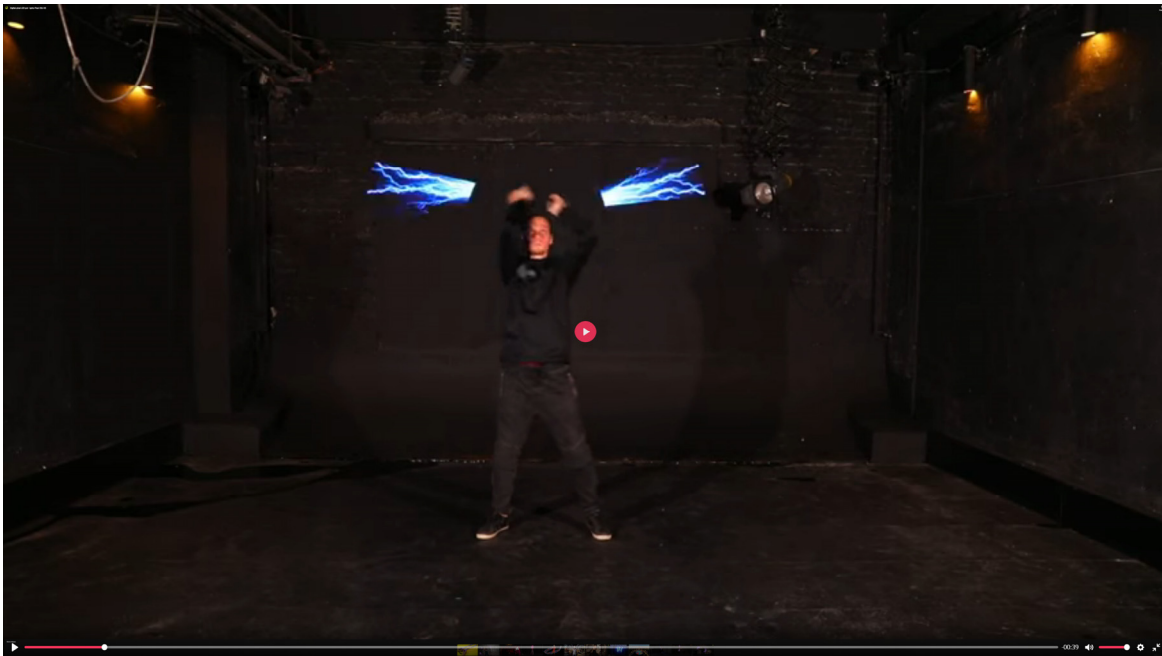
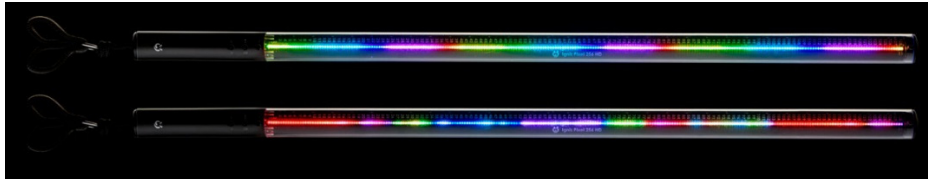

See, e.g., Ignis 256 HD product page, located at <https://ignispixel.com/product/ignis-pixel-poi-256-hd>





See, e.g., Ignis 200 HD product page, located at <https://ignispixel.com/product/ignis-pixel-poi-200-hd>

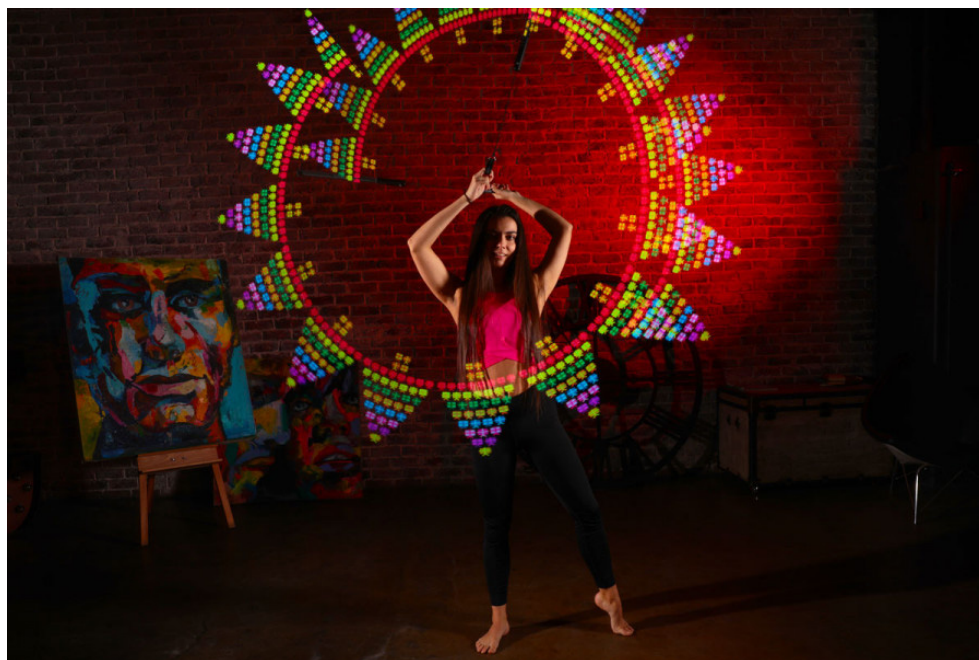
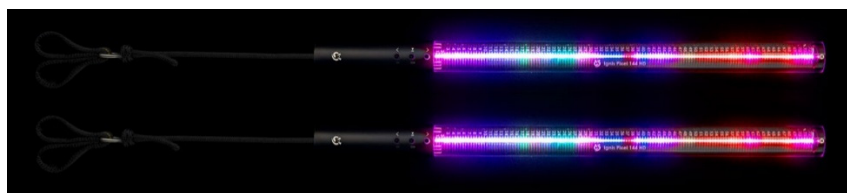

See, e.g., Ignis 144 HD product page, located at <https://ignispixel.com/product/ignis-pixel-poi-144-hd>

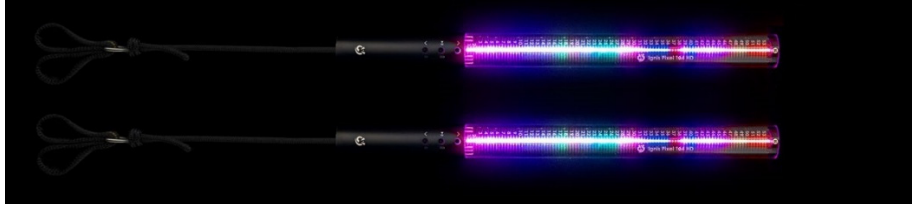

See, e.g., Ignis 104 HD product page, located at <https://ignispixel.com/product/ignis-pixel-poi-104-hd>





See, e.g., Ignis 80 HD product page, located at <https://ignispixel.com/product/ignis-pixel-poi-80-hd-tech>



See, e.g., Ignis 48 SD product page, located at <https://ignispixel.com/product/ignis-pixel-poi-48-lite>

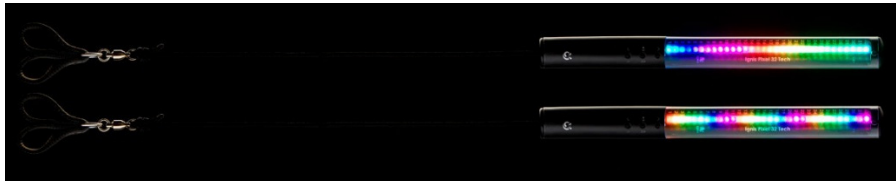





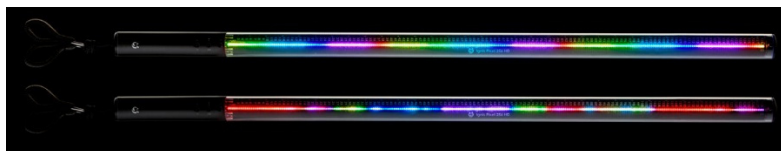



See, e.g., Ignis 32 SD product page, located at <https://ignispixel.com/product/ignis-pixel-poi-32-tech>

211. The Pixel system comprises the rotatable assembly including an illuminating display, said illuminating assembly being operably connected to said controller, said illuminating assembly including at least one illuminating element. For example, the Pixel system includes at least a collection or group of LEDs attached and/or connected, including via electric circuitry, to the controller for control and/or operation of the illuminating assembly, *inter alia*, by the controller:



The resolution of 256 pixels is the highest resolution on a pixel staff market. We fit 256 LEDs in 21.7 inch and supplied Ignis 256 HD with high rendering speed (2400 rows per second). The length of this LED poi is quite big, so all pictures are recognisable from big stages. High resolution, bright colors (8,6 billion) and high-rendering speed allow to astonish every single spectacular. This LED poi set is the best choice for people who love to amaze others and want to be at the cutting edge of technologies.

Technical characteristics

-  Resolution: 256 pixels 512 LEDs
-  Rendering speed: 2400 rows/second
-  Total length of poi: 67 cm (26.4")
-  Length of LED part: 55 cm (21.7")
-  Weight: 210 g (7.41 oz.)
-  Working time: 1.4h average; 15 min full white; up to 4h low brightness
-  Number of colors: 8.6 billion (Color depth 33 bit)
-  Battery capacity: 3500 mAh

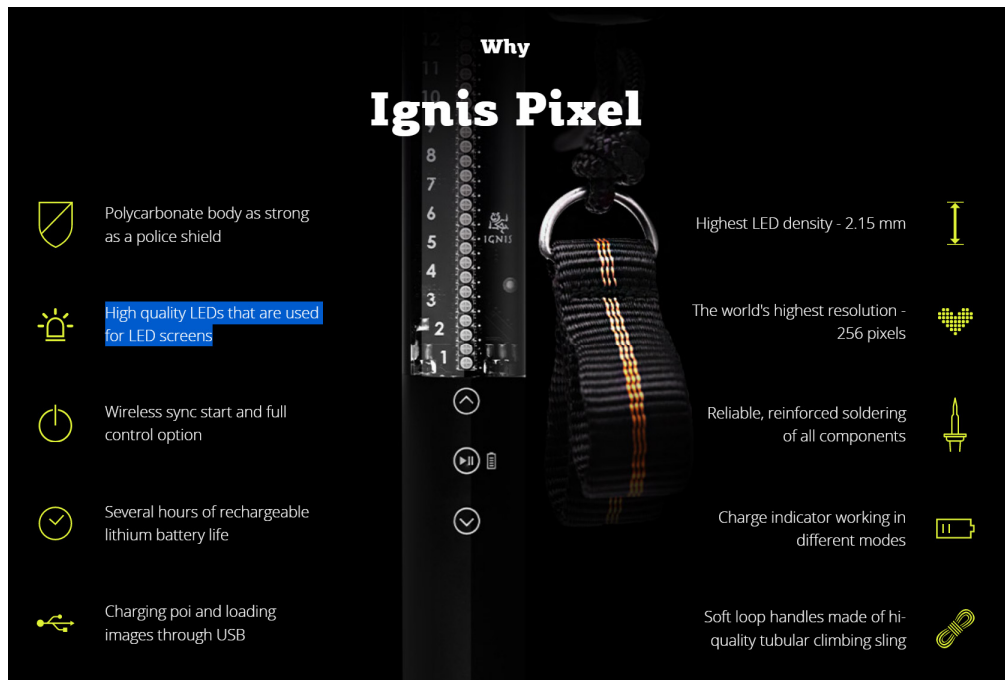









See, e.g., Ignis 256 HD product page, located at <https://ignispixel.com/product/ignis-pixel-poi-256-hd>







We also changed LEDs in new generation of Ignis Pixel 200 HD. New tiny LEDs show perfect colors with improved yellow and orange tones, that makes pictures on poi sharper, more realistic, and colorful. Synchronize your shows with music, adjust up to 10 timelines and make more money with our pixel equipment.

Technical characteristics





-  Resolution: 200 pixels (400 LEDs)
-  Rendering speed: 2600 rows/second
-  Total length of poi: 55 cm (21.7")
-  Length of LED part: 43 cm (16.9")
-  Weight: 190 g (6.7 oz.)
-  Working time: 1.5h average; 20 min full white; up to 5h low brightness
-  Number of colors: 8.6 billion (Color depth 33 bit)
-  Battery capacity: 3500 mAh

Why

Ignis Pixel

-  Polycarbonate body as strong as a police shield
-  High quality LEDs that are used for LED screens
-  Wireless sync start and full control option
-  Several hours of rechargeable lithium battery life
-  Charging poi and loading images through USB



- Highest LED density - 2.15 mm 
- The world's highest resolution - 256 pixels 
- Reliable, reinforced soldering of all components 
- Charge indicator working in different modes 
- Soft loop handles made of hi-quality tubular climbing sling 

See, e.g., Ignis 200 HD product page, located at <https://ignispixel.com/product/ignis-pixel-poi-200-hd>

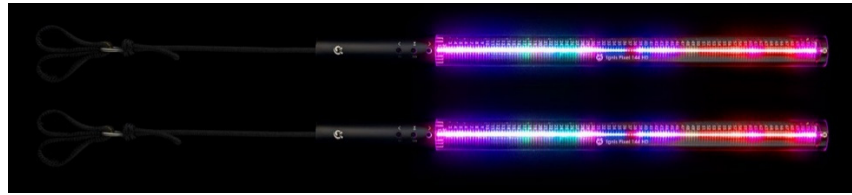

Ignis 144 HD are best for big show groups. This LED poi set allows to make technically advanced tricks such as spirals. Ignis 144 HD are also easily transformed into a doublestaff with the length of 34,2 inches and the world's highest resolution of 288 pixels. With these characteristics we guarantee that photos, logos, texts, and other graphic will be bright and readable not only at night, but also at lamplight.

Technical characteristics

- Resolution: 144 pixels (288 LEDs)
- Rendering speed: 3500 rows/second
- Total length of poi: 44 cm (17.3")
- Length of LED part: 31 cm (12.2")
- Weight: 160 g (5.64 oz.)
- Working time: 2h average; 26 min full white; up to 6h low brightness
- Number of colors: 8.6 billion (Color depth 33 bit)
- Battery capacity: 2600 mAh

Why

Ignis Pixel

- Polycarbonate body as strong as a police shield
- High quality LEDs that are used for LED screens
- Wireless sync start and full control option
- Several hours of rechargeable lithium battery life
- Charging poi and loading images through USB





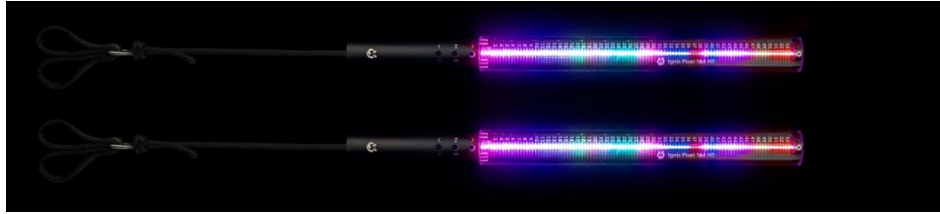



- Highest LED density - 2.15 mm
- The world's highest resolution - 256 pixels
- Reliable, reinforced soldering of all components
- Charge indicator working in different modes
- Soft loop handles made of high-quality tubular climbing sling

See, e.g., Ignis 144 HD product page, located at <https://ignispixel.com/product/ignis-pixel-poi-144-hd>







LED poi Ignis 104 HD is shortest digital poi with high 104-pixel resolution. Length of poi is only 35 cm, which is suitable for performing technically advanced spinning with elements such as spirals, wraps and even orbitals. 104 LEDs mounted with pitch 2,1 mm to each other and allows you to draw in the air not only pictures but also photos with faces of people who are easily recognized by the audience!

Technical characteristics





-  Resolution: 104 pixels (208 LEDs)
-  Rendering speed: 2600 rows/second
-  Total length of poi: 35 cm (13.8")
-  Length of LED part: 23 cm (9.1")
-  Weight: 140 g (4.94 oz.)
-  Working time: 2h average; 42 min full white; 5h low brightness
-  Number of colors: 8.6 billion (Color depth 33 bit)
-  Battery capacity: 2600 mAh

Why

Ignis Pixel

-  Polycarbonate body as strong as a police shield
-  High quality LEDs that are used for LED screens
-  Wireless sync start and full control option
-  Several hours of rechargeable lithium battery life
-  Charging poi and loading images through USB



- Highest LED density - 2.15 mm 
- The world's highest resolution - 256 pixels 
- Reliable, reinforced soldering of all components 
- Charge indicator working in different modes 
- Soft loop handles made of hi-quality tubular climbing sling 

See, e.g., Ignis 104 HD product page, located at <https://ignispixel.com/product/ignis-pixel-poi-104-hd>



Ignis 80 HD Tech is our flagship model for professional spinners. Ignis 80 HD Tech has the best balance between length, number of LEDs, and resolution on the market of pixel equipment. At first we made this model for such profies as Tim Goddard (@timmehtek) from Australia, Yuta Imamura (@yutapoi) from Japan, Ben Drexler (@drexfactor) from the USA, Gustavo Ollitta (@gollitta) from Brazil, but decided that Ignis 80 HD Tech deserves attention of other professionals. Short length (6.7 inch) allows to do spirals, wraps, orbitals, hyperloops and even juggling them. And due to the high resolution of 80 pixels, you can upload to this LED poi set texts, emoji, logos, graphic and also photos with people's faces and small details. Work with programmable LED poi sticks in the user-friendly software compatible with Windows and Mac OS. If our world record in resolution doesn't make sense to you, than pay attention to the rendering speed — 3 000 rows per second!

Technical characteristics

- Resolution: 80 pixels (160 LEDs)
- Rendering speed: 3000 rows/second
- Total length of poi: 29.5 cm (11.6")
- Length of LED part: 17 cm (6.7")
- Weight: 130 g (4.59 oz.)
- Working time: 2h average; 40 min full white; 5h low brightness
- Number of colors: 68 billion (Color depth 36 bit)
- Battery capacity: 2600 mAh

Why

Ignis Pixel

- Polycarbonate body as strong as a police shield
- High quality LEDs that are used for LED screens
- Wireless sync start and full control option
- Several hours of rechargeable lithium battery life
- Charging poi and loading images through USB

- Highest LED density - 2.15 mm
- The world's highest resolution - 256 pixels
- Reliable, reinforced soldering of all components
- Charge indicator working in different modes
- Soft loop handles made of hi-quality tubular climbing sling

See, e.g., Ignis 80 HD product page, located at <https://ignispixel.com/product/ignis-pixel-poi-80-hd-tech>



Ignis Pixel 48 Lite are best for those who aren't ready for huge investments in digital props, but have already started to make performances. Do wraps, spirals, orbitals, hyperloops and our poi sticks will take care of everything else — they are so bright that your show will be noticeable from a distance. For this purpose we supplied them with 96 bright LEDs, that help to see all pictures at night, lamplight and even in daylight.

Technical characteristics

- Resolution: 48 pixels **(96 LEDs)**
- Rendering speed: 1500 rows/second
- Total length of poi: 37 cm (14.6")
- Length of LED part: 24 cm (9.4")
- Weight: 150 g (5.29 oz.)
- Working time: Working time: 1,5h average; 32 min full white; 4h low brightness
- Number of colors: 68 billion (Color depth 36 bit)
- Battery capacity: 2600 mAh

Why

Ignis Pixel

- Polycarbonate body as strong as a police shield
- High quality LEDs that are used for LED screens**
- Wireless sync start and full control option
- Several hours of rechargeable lithium battery life
- Charging poi and loading images through USB





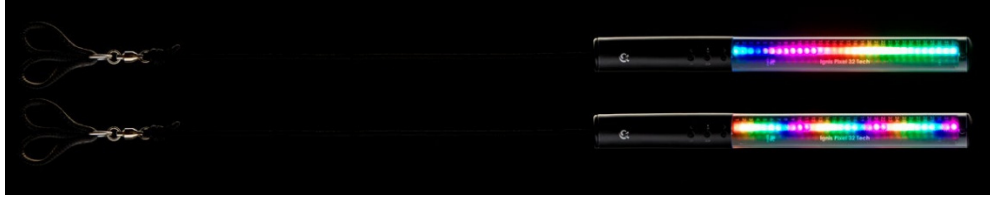



- Highest LED density - 2.15 mm
- The world's highest resolution - 256 pixels
- Reliable, reinforced soldering of all components
- Charge indicator working in different modes
- Soft loop handles made of high-quality tubular climbing sling

See, e.g., Ignis 48 SD product page, located at <https://ignispixel.com/product/ignis-pixel-poi-48-lite>







Short length and simplicity are the main advantages of this LED poi set. In the hands of professional artists Ignis Pixel 32 Tech become a huge weapon for making technically advanced tricks, such as spirals, wraps, orbitals, and even hyperloops due to bearing swivels. They also can become your best teacher if you start to spin a LED staff recently. Ignis Pixel 32 Tech have optimal length (11.4 inch), weight (4.2 oz) and are very user-friendly.

Technical characteristics





-  Resolution: 32 pixels (64 LEDs)
-  Rendering speed: 1500 rows/second
-  Total length of poi: 29 cm (11.4")
-  Length of LED part: 16 cm (6.3")
-  Weight: 130 g (4.59 oz.)
-  Working time: Working time: 1,5h average; 30 min full white; 4h low brightness
-  Number of colors: 68 billion (Color depth 36 bit)
-  Battery capacity: 2600 mAh

Why

Ignis Pixel

-  Polycarbonate body as strong as a police shield
-  High quality LEDs that are used for LED screens
-  Wireless sync start and full control option
-  Several hours of rechargeable lithium battery life
-  Charging poi and loading images through USB



- Highest LED density - 2.15 mm 
- The world's highest resolution - 256 pixels 
- Reliable, reinforced soldering of all components 
- Charge indicator working in different modes 
- Soft loop handles made of hi-quality tubular climbing sling 

See, e.g., Ignis 32 SD product page, located at <https://ignispixel.com/product/ignis-pixel-poi-32-tech>

212. The Pixel system comprises the rotatable assembly being constructed and arranged

for attachment to a support for rotation about an axis. For example, the Pixel system includes at least rope, string, or other similar material which, *inter alia*, permits the user to hold and/or keep a grip on the assembly, including while the user spins and/or rotates the assembly around an axis (e.g., around the user's arms, hands, body, etc.):

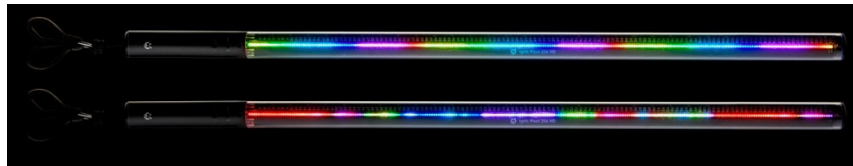

DESCRIPTION	SET INCLUDES	FILES
<p>The price is for a complete set, which includes:</p> <ul style="list-style-type: none">• Pair of Ignis 256 HD• Nylon loop handles with nylon cord• 2 Micro-USB cable for charging and upload pictures• Stylish two-ply bag with soft fleece lining		

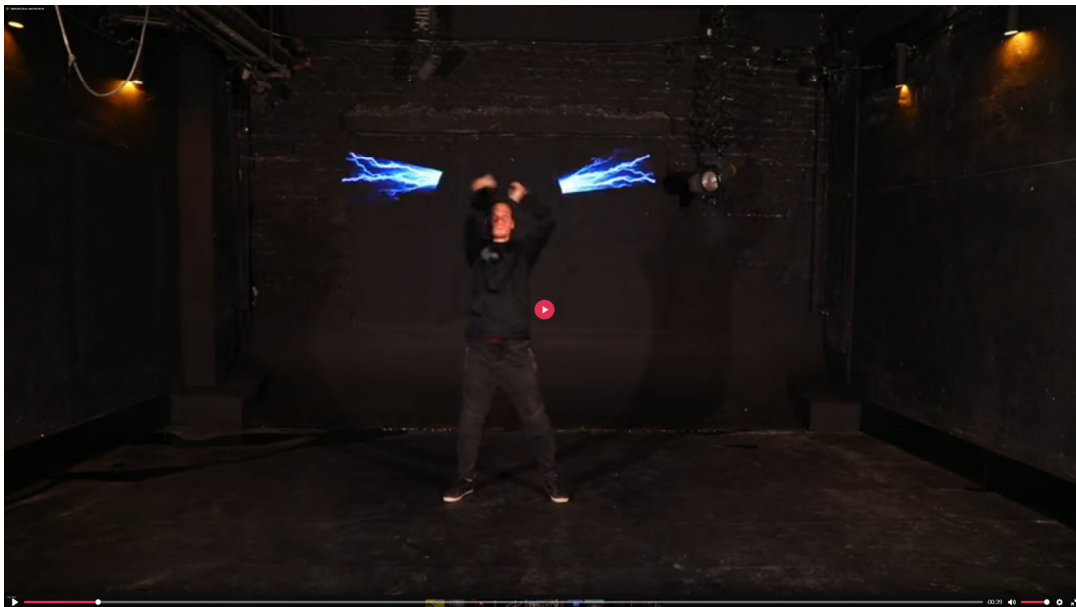

See, e.g., Ignis 256 HD product page, located at <https://ignispixel.com/product/ignis-pixel-poi-256-hd>



DESCRIPTION	SET INCLUDES	FILES
<p>The price is for a complete set, which includes:</p> <ul style="list-style-type: none">• Pair of Ignis 200 HD• Nylon loop handles with nylon cord• 2 Micro-USB cable for charging and upload pictures• Stylish two-ply bag with soft fleece lining		

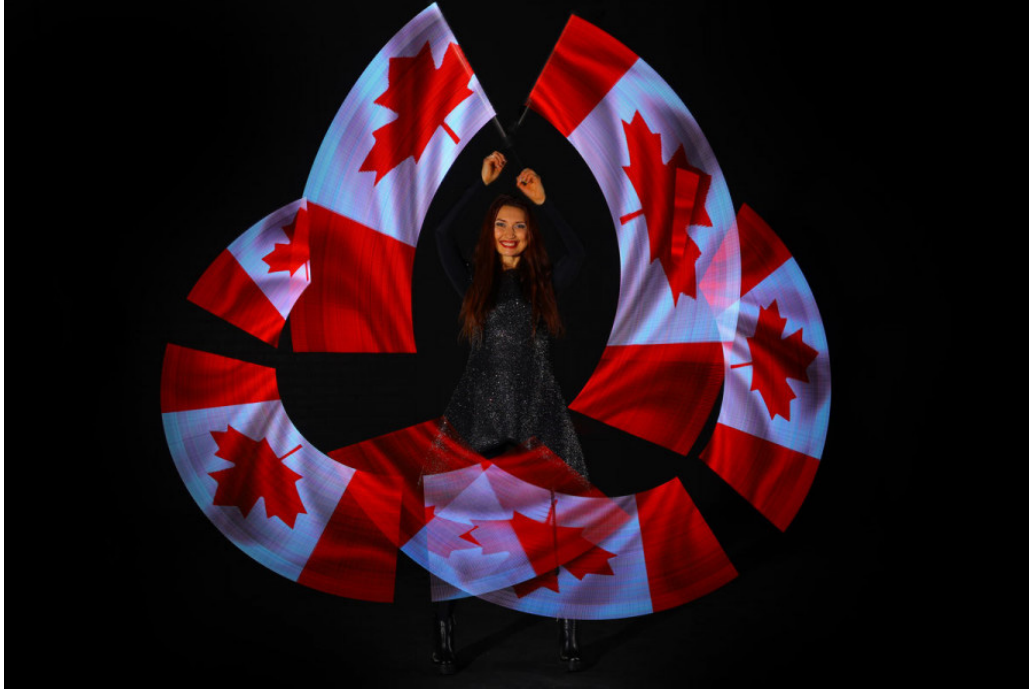

See, e.g., Ignis 200 HD product page, located at <https://ignispixel.com/product/ignis-pixel-poi-200-hd>

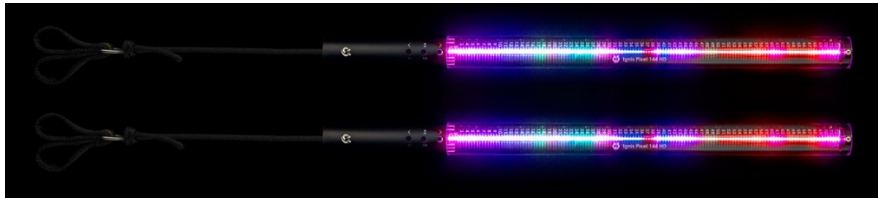

DESCRIPTION	SET INCLUDES	FILES
<p>The price is for a complete set, which includes:</p> <ul style="list-style-type: none">• Pair of Ignis 144 HD• Nylon loop handles with nylon cord• 2 Micro-USB cable for charging and upload pictures• Stylish two-ply bag with soft fleece lining		



See, e.g., Ignis 144 HD product page, located at <https://ignispixel.com/product/ignis-pixel-poi-144-hd>

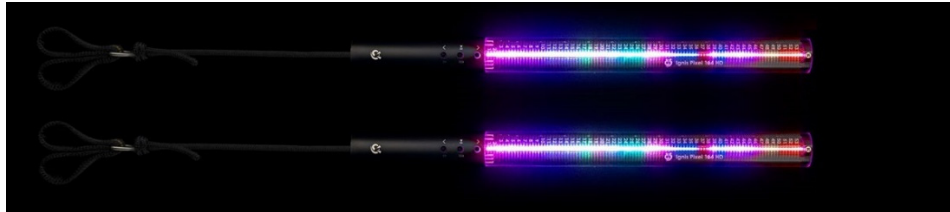

DESCRIPTION	SET INCLUDES	FILES
<p>The price is for a complete set, which includes:</p> <ul style="list-style-type: none">• Pair of Ignis 104 HD• Nylon loop handles with nylon cord• 2 Micro-USB cable for charging and upload pictures• Stylish two-ply bag with soft fleece lining		



See, e.g., Ignis 104 HD product page, located at <https://ignispixel.com/product/ignis-pixel-poi-104-hd>





DESCRIPTION

SET INCLUDES

FILES

The price is for a complete set, which includes:

- Pair of Ignis 80 HD
- Nylon loop handles with nylon cord
- 2 Micro-USB cable for charging and upload pictures
- Stylish two-ply bag with soft fleece lining



See, e.g., Ignis 80 HD product page, located at <https://ignispixel.com/product/ignis-pixel-poi-80-hd-tech>

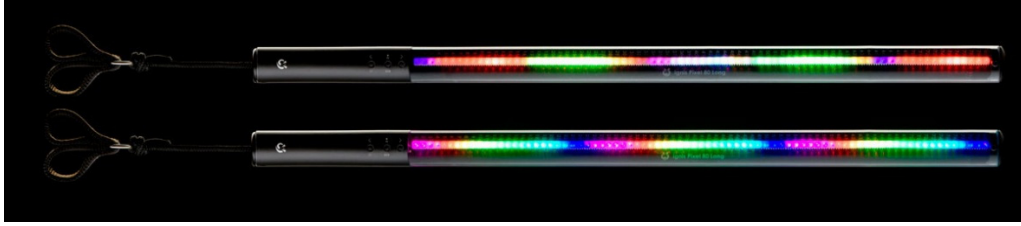

DESCRIPTION	SET INCLUDES	FILES
<p>The price is for a complete set, which includes:</p> <ul style="list-style-type: none">• Pair of Ignis 80 SD• Nylon loop handles with nylon cord• 2 Micro-USB cable for charging and upload pictures• Stylish two-ply bag with soft fleece lining		

See, e.g., Ignis 80 SD product page, located at <https://ignispixel.com/product/ignis-pixel-poi-80>



DESCRIPTION	SET INCLUDES	FILES
<p>The price is for a complete set, which includes:</p> <ul style="list-style-type: none">• Pair of Ignis 48 SD• Nylon loop handles with nylon cord• 2 Micro-USB cable for charging and upload pictures• Stylish two-ply bag with soft fleece lining		



See, e.g., Ignis 48 SD product page, located at <https://ignispixel.com/product/ignis-pixel-poi-48-lite>





DESCRIPTION

SET INCLUDES

FILES

The price is for a complete set, which includes:

- Pair of Ignis 32 SD
- Nylon loop handles with nylon cord
- 2 Micro-USB cable for charging and upload pictures
- Stylish two-ply bag with soft fleece lining











See, e.g., Ignis 32 SD product page, located at <https://ignispixel.com/product/ignis-pixel-poi-32-tech>

213. The Pixel system comprises a power delivery means for providing power to said

rotatable assembly. For example, the Pixel system includes at least a battery contained within the Poi device which provides electric current to power the assembly and the illumination elements therein:

Technical characteristics



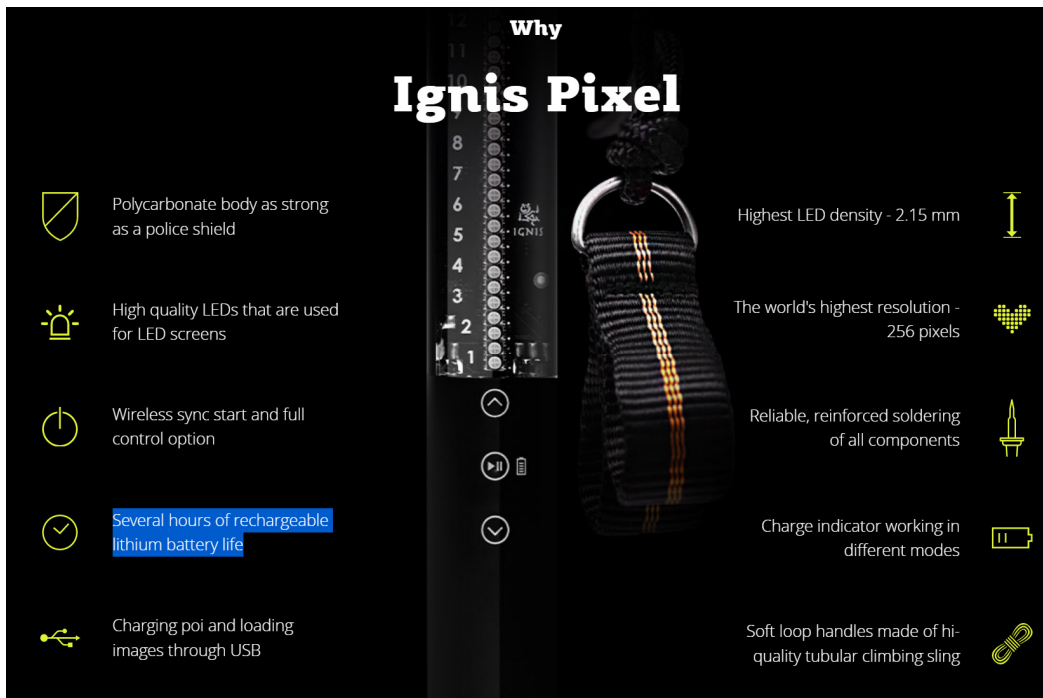





-  Resolution: 256 pixels (512 LEDs)
-  Rendering speed: 2400 rows/second
-  Total length of poi: 67 cm (26.4")
-  Length of LED part: 55 cm (21.7")
-  Weight: 210 g (7.41 oz.)
-  Working time: 1.4h average; 15 min full white; up to 4h low brightness
-  Number of colors: 8.6 billion (Color depth 33 bit)
-  **Battery capacity: 3500 mAh**













The image is a screenshot of the Ignis Pixel product page. At the top, it says "Why Ignis Pixel". The central image shows the Ignis Pixel device, a black cylindrical object with a silver ring at the top and a USB-C port at the bottom. The device has a digital display showing numbers 1 through 10. To the left of the device, there are five bullet points with icons: a shield for "Polycarbonate body as strong as a police shield", a lightbulb for "High quality LEDs that are used for LED screens", a power button for "Wireless sync start and full control option", a checkmark for "Several hours of rechargeable lithium battery life", and a USB-C icon for "Charging poi and loading images through USB". To the right of the device, there are three bullet points with icons: a vertical double-headed arrow for "Highest LED density - 2.15 mm", a heart-shaped LED array for "The world's highest resolution - 256 pixels", and a soldering iron for "Reliable, reinforced soldering of all components". Below these are two more bullet points: a battery icon for "Charge indicator working in different modes" and a climbing sling icon for "Soft loop handles made of hi-quality tubular climbing sling".

See, e.g., Ignis 256 HD product page, located at <https://ignispixel.com/product/ignis-pixel-poi-256-hd>

Technical characteristics









-  Resolution: 200 pixels (400 LEDs)
-  Rendering speed: 2600 rows/second
-  Total length of poi: 55 cm (21.7")
-  Length of LED part: 43 cm (16.9")
-  Weight: 190 g (6.7 oz.)
-  Working time: 1.5h average; 20 min full white; up to 5h low brightness
-  Number of colors: 8.6 billion (Color depth 33 bit)
-  **Battery capacity: 3500 mAh**

Why Ignis Pixel

-  Polycarbonate body as strong as a police shield
-  High quality LEDs that are used for LED screens
-  Wireless sync start and full control option
-  **Several hours of rechargeable lithium battery life**
-  Charging poi and loading images through USB
-  Highest LED density - 2.15 mm
-  The world's highest resolution - 256 pixels
-  Reliable, reinforced soldering of all components
-  Charge indicator working in different modes
-  Soft loop handles made of high-quality tubular climbing sling

See, e.g., Ignis 200 HD product page, located at <https://ignispixel.com/product/ignis-pixel-poi-200-hd>

Technical characteristics

-  Resolution: 144 pixels (288 LEDs)
-  Rendering speed: 3500 rows/second
-  Total length of poi: 44 cm (17.3")
-  Length of LED part: 31 cm (12.2")
-  Weight: 160 g (5.64 oz.)
-  Working time: 2h average; 26 min full white; up to 6h low brightness
-  Number of colors: 8.6 billion (Color depth 33 bit)
-  **Battery capacity: 2600 mAh**

Why Ignis Pixel

- Polycarbonate body as strong as a police shield
- High quality LEDs that are used for LED screens
- Wireless sync start and full control option
- Several hours of rechargeable lithium battery life
- Charging poi and loading images through USB
- Highest LED density - 2.15 mm
- The world's highest resolution - 256 pixels
- Reliable, reinforced soldering of all components
- Charge indicator working in different modes
- Soft loop handles made of hi-quality tubular climbing sling

See, e.g., Ignis 144 HD product page, located at <https://ignispixel.com/product/ignis-pixel-poi-144-hd>

Technical characteristics

- Resolution: 104 pixels (208 LEDs)
- Rendering speed: 2600 rows/second
- Total length of poi: 35 cm (13.8")
- Length of LED part: 23 cm (9.1")
- Weight: 140 g (4.94 oz.)
- Working time: 2h average; 42 min full white; 5h low brightness
- Number of colors: 8.6 billion (Color depth 33 bit)
- Battery capacity: 2600 mAh

Why Ignis Pixel

- Polycarbonate body as strong as a police shield
- High quality LEDs that are used for LED screens
- Wireless sync start and full control option
- Several hours of rechargeable lithium battery life
- Charging poi and loading images through USB
- Highest LED density - 2.15 mm
- The world's highest resolution - 256 pixels
- Reliable, reinforced soldering of all components
- Charge indicator working in different modes
- Soft loop handles made of hi-quality tubular climbing sling

See, e.g., Ignis 104 HD product page, located at <https://ignispixel.com/product/ignis-pixel-poi-104-hd>

Technical characteristics

- Resolution: 80 pixels (160 LEDs)
- Rendering speed: 3000 rows/second
- Total length of poi: 29.5 cm (11.6")
- Length of LED part: 17 cm (6.7")
- Weight: 130 g (4.59 oz.)
- Working time: 2h average; 40 min full white; 5h low brightness
- Number of colors: 68 billion (Color depth 36 bit)
- Battery capacity: 2600 mAh

Why

Ignis Pixel

- Polycarbonate body as strong as a police shield
- High quality LEDs that are used for LED screens
- Wireless sync start and full control option
- Several hours of rechargeable lithium battery life
- Charging poi and loading images through USB
- Highest LED density - 2.15 mm
- The world's highest resolution - 256 pixels
- Reliable, reinforced soldering of all components
- Charge indicator working in different modes
- Soft loop handles made of hi-quality tubular climbing sling

See, e.g., Ignis 80 HD product page, located at <https://ignispixel.com/product/ignis-pixel-poi-80-hd-tech>





Technical characteristics





- Resolution: 48 pixels (96 LEDs)
- Rendering speed: 1500 rows/second
- Total length of poi: 37 cm (14.6")
- Length of LED part: 24 cm (9.4")
- Weight: 150 g (5.29 oz.)
- Working time: Working time: 1,5h average; 32 min full white; 4h low brightness
- Number of colors: 68 billion (Color depth 36 bit)
- Battery capacity: 2600 mAh

Why

Ignis Pixel











-  Polycarbonate body as strong as a police shield
-  High quality LEDs that are used for LED screens
-  Wireless sync start and full control option
-  Several hours of rechargeable lithium battery life
-  Charging poi and loading images through USB

-  Highest LED density - 2.15 mm
-  The world's highest resolution - 256 pixels
-  Reliable, reinforced soldering of all components
-  Charge indicator working in different modes
-  Soft loop handles made of hi-quality tubular climbing sling

See, e.g., Ignis 48 SD product page, located at <https://ignispixel.com/product/ignis-pixel-poi-48-lite>

Technical characteristics

-  Resolution: 32 pixels (64 LEDs)
-  Rendering speed: 1500 rows/second
-  Total length of poi: 29 cm (11.4")
-  Length of LED part: 16 cm (6.3")
-  Weight: 130 g (4.59 oz.)
-  Working time: Working time: 1,5h average; 30 min full white; 4h low brightness
-  Number of colors: 68 billion (Color depth 36 bit)
-  Battery capacity: 2600 mAh

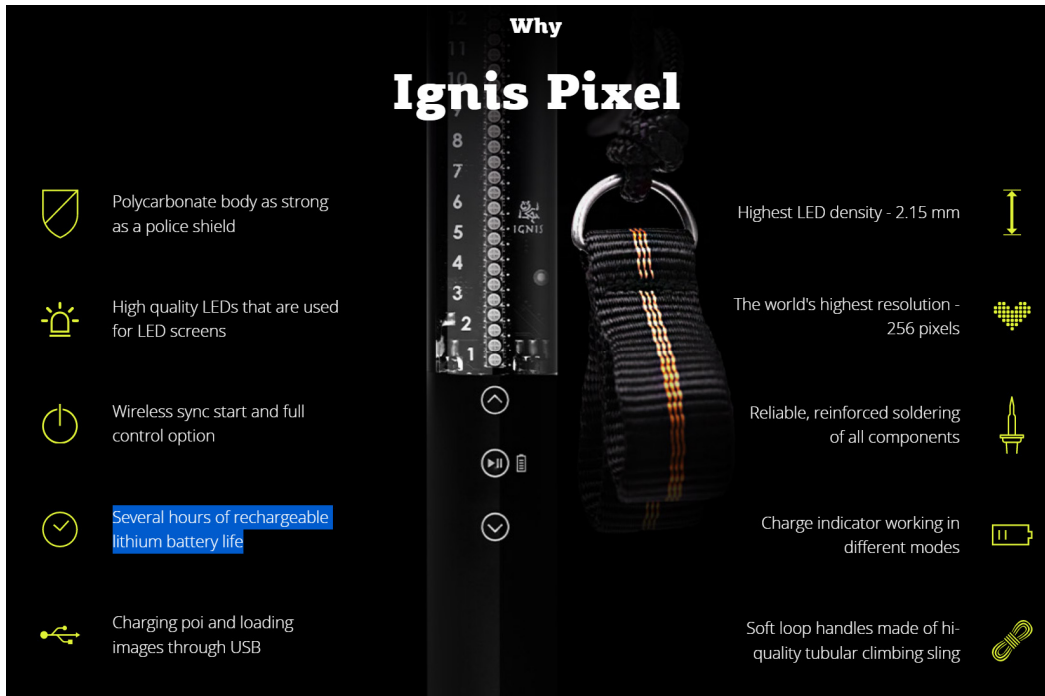

See, e.g., Ignis 32 SD product page, located at <https://ignispixel.com/product/ignis-pixel-poi-32-tech>

214. The Pixel system comprises an image represented by said data transferred from said computer to the controller displayed by said rotatable assembly during rotation of said rotatable assembly, said image displayed without bending the horizontal ground plane around said axis, including, for example, at least the Poi device creating a POV image based, *inter alia*, on the data received at the controller from the computer and via, *inter alia*, the controller selectively changing the illumination elements such that the image is created in a manner which does not distort the image around the axis about which the Poi device is being rotated:

Programming timeline modes (time-programmed sequence of pictures).

You can set the duration for each uploaded picture, thus creating a sequence of them, synchronized with the music. There are ten timeline custom sequences, T1-T10.

To configure the timeline:

1. Run Ignis Pixel Utility;
2. Open single pictures from files through menu **Add -> Image** or drag and drop files to the Image list into the left upper area of Ignis Pixel Utility;
3. Select images in Image list, drag and drop them to a timeline (T1-T10) to the lower area of Ignis Pixel Utility;
4. Now you see a sequence of pictures. You can change their order and duration by dragging them or their borders, like in video editors. Use Ctrl (Cmd for MacOS) button to change editing method Ripple edit/Rolling edit;
5. To adjust the timeline synchronously with music, add your music file through menu **Add -> Music** or drag and drop an MP3 file to the Music slot of Ignis Pixel Utility (lower area, just above the timelines);
6. Connect your digital poi to your computer with Micro-USB cables and press **Scan** button in the **Device list** (right area of Ignis Pixel Utility);
7. Click **"Upload all"** button – the process can take up to several minutes depending on the poi model and height-width ratios of the pictures.
8. When you change only a duration or an order of pictures in a timeline to save time, just tick the required timeline and click **"Upload Checked"** – the process will take just a few seconds.

Saving your project

The software allows you to save the project, and you can send your project by e-mail or USB flash to another computer. You do not need to send the original pictures of your project. They are contained within the project file.

See, e.g., Manual for Ignis Pixel Poi at page 4, located at https://ignispixel.com/files/upload/manual/Manual_Ignis_Pixel_v3_EN.pdf

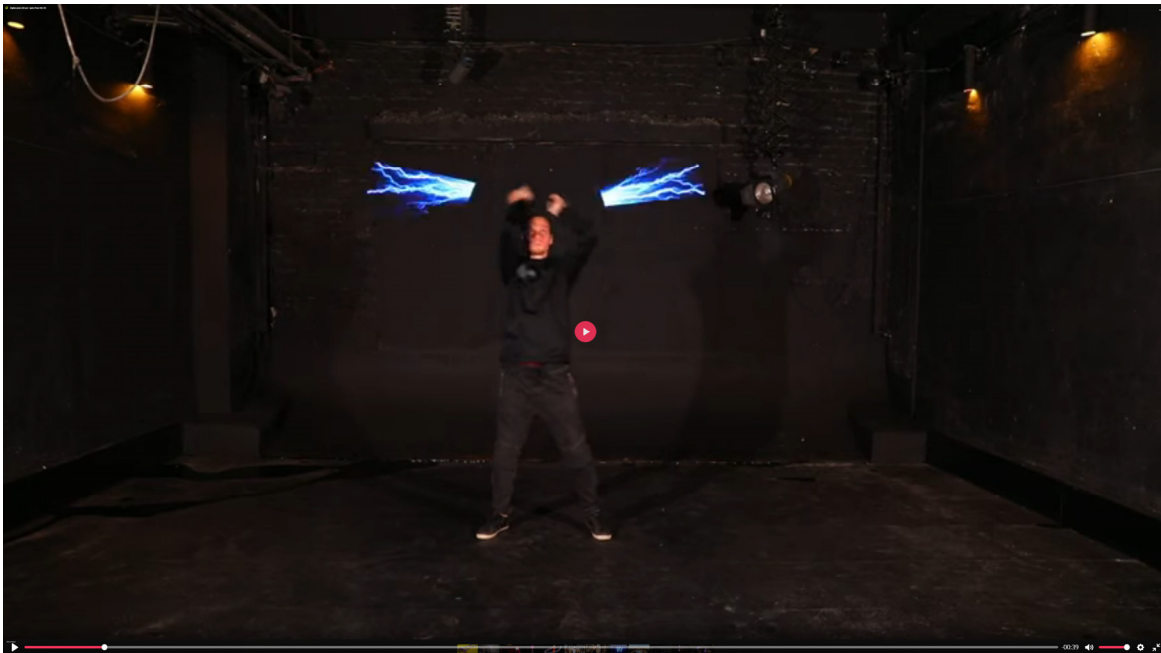
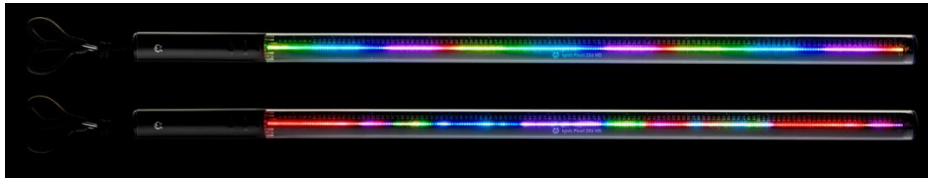

See, e.g., Ignis 256 HD product page, located at <https://ignispixel.com/product/ignis-pixel-poi->

[256-hd](#)



See, e.g., Ignis 200 HD product page, located at <https://ignispixel.com/product/ignis-pixel-poi-200-hd>

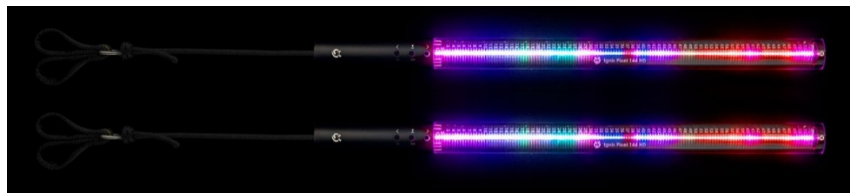

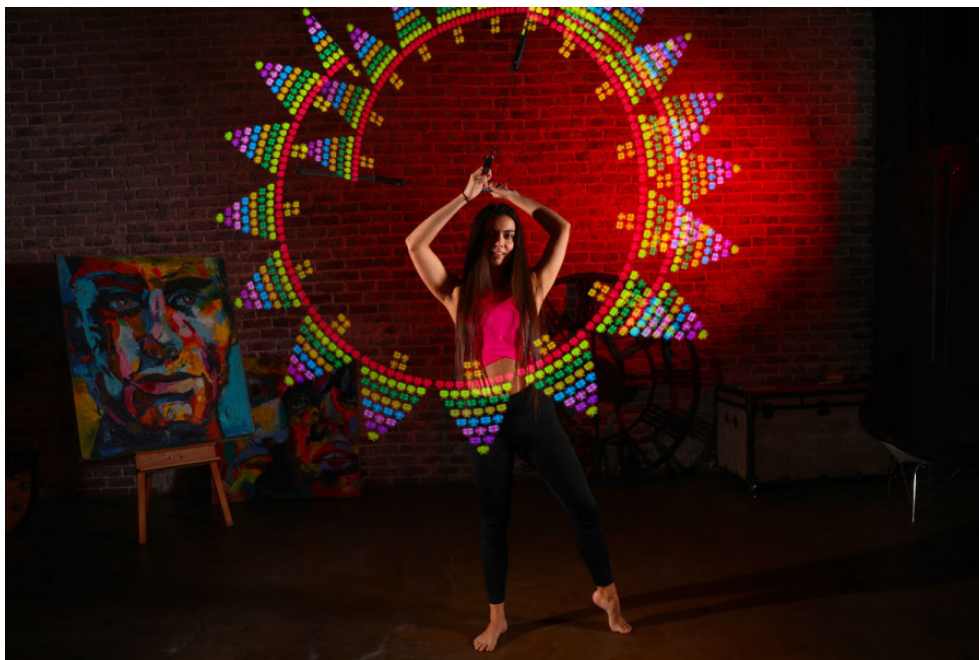

See, e.g., Ignis 144 HD product page, located at <https://ignispixel.com/product/ignis-pixel-poi-144-hd>

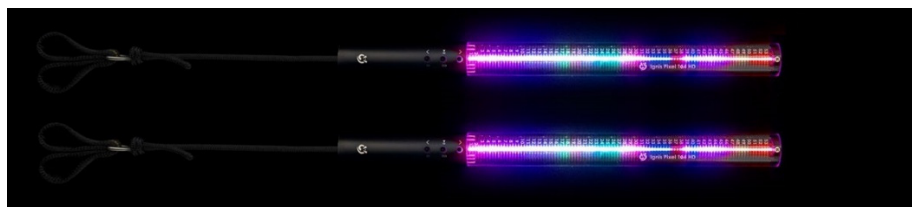

See, e.g., Ignis 104 HD product page, located at <https://ignispixel.com/product/ignis-pixel-poi-104-hd>



See, e.g., Ignis 80 HD product page, located at <https://ignispixel.com/product/ignis-pixel-poi-80-hd-tech>





See, e.g., Ignis 48 SD product page, located at <https://ignispixel.com/product/ignis-pixel-poi-48-lite>



See, e.g., Ignis 32 SD product page, located at <https://ignispixel.com/product/ignis-pixel-poi-32-tech>

215. Upon information and belief, Defendant will have been on actual notice of the '108 Patent since, at the latest, the service of this Complaint, and, at the earliest, in February of 2017, or soon thereafter, when Plaintiff's founder, Mark, contacted Defendant's founder and requested a meeting regarding the technologies described in the Patents-in-Suit in relation to the implementation of such technologies in Defendant's devices at the time. Moreover, Defendant has had actual notice since at least as early as June 30, 2023, when Plaintiff's founder, again, contacted Defendant regarding potential infringement of the Patents-in-Suit. At a minimum, Defendant has had at least constructive notice of the '108 Patent since at least its issuance, and by virtue of the fact that Defendant was made aware of Plaintiff's products embodying the '108 Patent which were marked at least by virtue of the listing of the Patents-in-Suit on Plaintiff's website.

216. Additionally, and/or in the alternative, at least since receiving notice of the '108 Patent, including, if necessary, from this suit and Complaint, Defendant has induced, and continues to induce, infringement of the '108 Patent in this Judicial District, and elsewhere, including in violation of 35 U.S.C. § 271(b), including by actions comprising actively inducing direct infringement of the '108 Patent, including by knowingly and/or actively aiding and/or abetting infringement by customers and/or users, by and through at least instructing and encouraging the use of the Pixel systems, services, products, devices, and software noted herein, including the Pixel systems. Such aiding and/or abetting comprises providing software, products, user devices, and/or instructions regarding the use and/or operation of the Pixel systems, applications, servers, services, products, and devices in an infringing manner. Such induced infringement has occurred at least since Defendant became aware of the '108 Patent, at a minimum, as noted herein, and the knowledge and awareness that such actions by customers and/or other end users comprise infringement of the '108 Patent.

217. Additionally, and/or in the alternative, since receiving notice of the '108 Patent,

including, if necessary, from this suit and Complaint, Defendant has contributed, and continues to contribute, to infringement of the '108 Patent in this Judicial District, and elsewhere, including in violation of 35 U.S.C. § 271(c), including by actions comprising contributing to the direct infringement of the '108 Patent, including via at least the use of said systems, services, products, devices, and software noted herein, including the use of the Pixel systems by customers and/or other end users. Such contributions necessarily comprise providing software, products, user devices, and/or instructions regarding the use and/or operation of the Pixel systems, applications, servers, services, products, and devices in an infringing manner, with the knowledge that such systems, applications, servers, services, products, and devices are especially made and/or especially adapted for use in an infringing manner and not a staple article and/or commodity of commerce suitable for substantial non-infringing use. Such contributory infringement has occurred since Defendant became aware of the '108 Patent, at a minimum, as noted herein, and the knowledge and awareness that such actions by customers and/or other end users comprise infringement of the '108 Patent.

218. The Pixel systems clearly meet the asserted claim limitations in their normal and expected usage. Upon information and belief, normal and expected usage of the Pixel systems by customers and/or end users satisfies the claim limitations for at least direct infringement. Further, at minimum, the provision of products, systems, and/or functionalities clearly capable of such infringing usage and/or provision of instructions/specifications for such infringing usage constitutes inducement of and/or contributing to directly infringing usage. Thus, by the time of trial, Defendant will have known and intended (at least since receiving such notice) that its continued actions would actively induce and/or contribute to the infringement of the asserted claims of the '108 Patent, including by customers and/or other end users.

219. Further, including as noted above, Defendant is being made aware of infringement

of the '108 Patent through use of the Pixel systems at least via the infringement allegations set forth herein. Such direct, induced, and/or contributory infringement has been, and remains, clear, unmistakable, and inexcusable. Upon information and belief, Defendant knew, or should have known, of the clear, unmistakable, and inexcusable direct, induced, and/or contributory infringing conduct described herein at least since receiving notice of the '108 Patent. Thus, upon information and belief, Defendant has, at least since receiving notice of the '108 Patent, specifically intended to directly and/or indirectly infringe, including via direct infringement of customers and/or end users.

220. Plaintiff believes and contends that, at a minimum, Defendant's knowing and intentional post-notice and/or post-suit continuance of its unjustified, clear, and inexcusable infringement of the '108 Patent since receiving notice of its infringement of the '108 Patent, is necessarily willful, wanton, malicious, in bad-faith, deliberate, conscious, and wrongful, and it constitutes egregious conduct worthy of a finding of willful infringement. Accordingly, at least since receiving notice of this suit and/or the '108 Patent, Defendant has willfully infringed the '108 Patent.

REMEDY AND DAMAGES

221. Plaintiff hereby refers to, and incorporates by reference, the allegations in the above paragraphs as if set forth fully herein.

222. Defendant's infringement of Plaintiff's rights under the Patents-in-Suit will continue to damage Plaintiff, causing irreparable harm for which there is no adequate remedy at law, unless enjoined by this Court, including under 35 U.S.C. § 283.

223. By way of its infringing activities, Defendant has caused, and continues to cause, Plaintiff to suffer damages, and Plaintiff is entitled to recover from Defendant the damages sustained by Plaintiff as a result of Defendant's wrongful acts in an amount subject to proof at

trial, which, by law, cannot be less than a reasonable royalty, together with interest and costs as fixed by this Court, including under 35 U.S.C. § 284.

224. Plaintiff also requests that this Court make a finding that this is an exceptional case entitling Plaintiff to recover its attorneys' fees and costs, including pursuant to 35 U.S.C. § 285.

DEMAND FOR JURY TRIAL

225. Pursuant to Rule 38 of the FEDERAL RULES OF CIVIL PROCEDURE, Plaintiff hereby respectfully requests a trial by jury of any issues so triable by right.

PRAYER FOR RELIEF

WHEREFORE, Plaintiff hereby respectfully requests that this Court enter judgment in favor of Plaintiff and against Defendant, and that the Court grant Plaintiff the following relief:

- A. That this Court enter Judgment including an adjudication that one or more claims of the Patents-in-Suit has been directly and/or indirectly infringed by Defendant, including pursuant to 35 U.S.C. § 281;
- B. That this Court enter Judgment including a grant of a preliminary and permanent injunction, including pursuant to 35 U.S.C. § 283, enjoining Defendant and all persons, including its officers, directors, agents, servants, affiliates, employees, divisions, branches, subsidiaries, parents, and all others acting in active concert or participation therewith, from making, using, offering to sell, and/or selling in the United States and/or importing into the United States any systems and/or devices that directly and/or indirectly infringe any claim of the Patents-in-Suit, and/or any systems and/or devices that are not more than colorably different;
- C. That this Court enter Judgment including an award to Plaintiff of damages, including pursuant to 35 U.S.C. § 284, adequate to compensate Plaintiff for Defendant's past infringement, together with pre-judgment and post-judgment interest, and any

- continuing and/or future infringement through the date such Judgment is entered, including all applicable, legally allowable, interest, costs, expenses, and an accounting of all infringing acts, including, but not limited to, those acts not presented at trial;
- D. That this Court enter Judgment including a declaration that Defendant's post-notice infringement has been, and continues to be, willful, including that Defendant acted to infringe any of the Patents-in-Suit despite an objectively high likelihood that its actions constituted infringement of a valid patent and, accordingly, award enhanced damages, including treble damages, including pursuant to 35 U.S.C. §§ 284 & 285;
- E. That this Court enter Judgment including a declaration that this case is an exceptional case and award Plaintiff reasonable attorneys' fees and costs, including in pursuant to 35 U.S.C. § 285; and
- F. Any and all such other and further relief to which Plaintiff may be shown justly entitled that this Court deems just and proper.

Dated: July 18, 2023

Respectfully submitted,

HOUSTONIP

/s/ Sugouri S. Batra

Sugouri S. Batra (Bar No. 1000426)

sugouri@houstonip.com

Shea N. Palavan (*pro hac vice* to be filed)

shea@houstonip.com

5353 West Alabama Street, Suite 303

Houston, Texas 77056

4590 MacArthur Boulevard, Suite 500

Newport Beach, California 92660

Telephone: (832) 800-4133

Facsimile: (855) PALAVAN (725-2826)

Attorneys for Plaintiff,

Spin Screen, Inc.