

Preston P. Frischknecht (#11286)
PROJECT CIP PLLC
399 North Main, Suite 220
Logan, UT 84321
Telephone: (435) 512-4893
preston@projectcip.com

Attorneys for Plaintiff Hydrojug

IN THE UNITED STATES DISTRICT COURT
FOR THE DISTRICT OF UTAH

HYDROJUG, INC, a Delaware corporation,

Plaintiff,

v.

BSM ENTERPRISE, LTD., a Chinese
company, and FIVE BELOW, INC, a
Pennsylvania corporation.

Defendants,

COMPLAINT

Case No.

COMPLAINT

Plaintiff Hydrojug Inc. (“Hydrojug”) complains against defendants BSM Enterprise, Ltd. (“BSM”) and Five Below, Inc. (“Five Below”) (collectively, “Defendants”) for the causes of action alleged as follows:

THE PARTIES

1. Hydrojug is a Delaware corporation with a principle place of business of 1017 West 600 North, Ste 1, Ogden, UT 84404.
2. Hydrojug alleges that BSM is a Chinese company with an address of No. 160 East Jinyuan Lan, Jiangdong, Ningbo, China 315040.

3. Hydrojug alleges that Five Below is a Pennsylvania corporation, registered as a foreign corporation in Utah, with stores nationwide and several fully owned brick and mortar locations in Utah.

JURISDICTION AND VENUE

4. This is a civil action for patent infringement under 35 U.S.C. §§ 1 et seq., including 35 U.S.C. § 271.

5. This Court has original jurisdiction over the subject matter of this action under at least 28 U.S.C. §§ 1331, 1332 and 1338(a).

6. This Court has personal jurisdiction over Five Below because it is registered as a foreign corporation in Utah, owns physical stores in Utah, does substantial business in Utah, and directs and sells infringing products (“Accused Products” below) in Utah. This Court also has personal jurisdiction over BSM because BSM places infringing products (“Accused Products”) into the stream of commerce directed at Utah and engages in conduct purposefully directed at Utah, by, for example: (a) marketing and selling its infringing products to Five Below – a known national retailer with stores in Utah; and (b) agreeing in writing to indemnify Five Below in any action against Five Below, including action in the State of Utah, among other contractual arrangements with Five Below relating to Five Below’s sale of infringing products in Utah, and performing in accordance therewith.

7. Venue is proper in this judicial district under at least 28 U.S.C. § 1400(b) and 28 U.S.C. § 1391 since Defendants conduct business in this Judicial District and a substantial portion of the events or omissions giving rise to this action occurred in this Judicial District. Further, venue is proper with respect to Five Below because it has multiple physical, regular, and established places of business in the district. Venue is further proper as against BSM under 28

USC 1391(c)(3) because it is a Chinese company and a defendant not resident in the United States may be sued in any judicial district.

FACTUAL BACKGROUND

8. Hydrojug is a domestic and global retailer of large, specialized water bottles for fitness.

9. Hydrojug started selling its signature, half-gallon water bottles in 2016, and soon thereafter expanded its product line to include water bottle sleeves and carriers specially designed to fit and be used with its oversized water bottles, as well as straws and other accessories.

10. The predominant focus of Hydrojug's products and marketing is encouraging people to hydrate and drink water.

11. Hydrojug also has unique product designs that are protected by a portfolio of patents and patent applications, including United States Design Patent No. D889,914 for a CONTAINER SLEEVE ("the '914 Patent") design that surrounds water bottles. The '914 Patent is attached hereto as "Exhibit A."

12. Five Below was aware of Hydrojug, its products, and its patents at least as early mid-2022, when Five Below knocked off Hydrojug's signature water bottle—as set forth in the case of *Hydrojug v. Five Below, et al.*, Case No. 1:22-cv-728 (United States District Court, Northern District of Ohio) ("the Ohio Case"). See the Ohio Case, Docket No. 40 (Order Granting Preliminary Injunction against Five Below, attached hereto as "Exhibit B") and/or 2022 WL 4017443.

13. Around and/or after the time that the Ohio Case settled, Defendants began offering GYM GROWLER-branded water bottle sleeves ("the Accused Products") in Five Below stores, including in Utah.

14. The Accused Products specifically fit Hydrojug's unique water bottles—including those that were the subject of the Ohio Case—and are very highly similar and/or identical in design to that of Hydrojug's patented sleeve design. For example, they have the same and/or highly similar shape and dimensions, tubular and continuous side, apertures, and pockets:

The '914 Patent

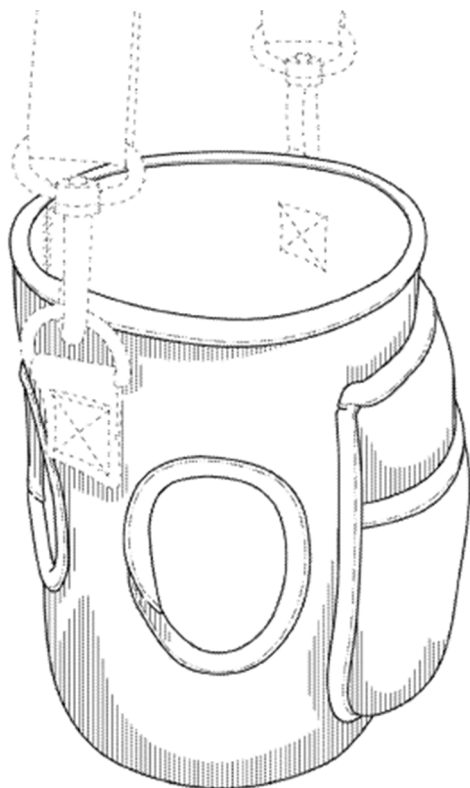

FIG. 1

*The Accused Products
(with Hydrojug Bottle)*



The '914 Patent

*The Accused Products
(with Hydrojug Bottle)*

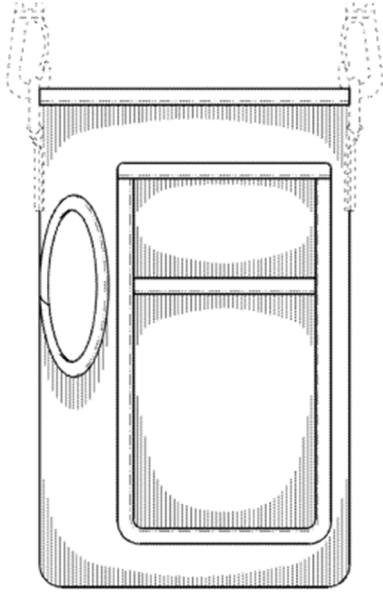

FIG. 2

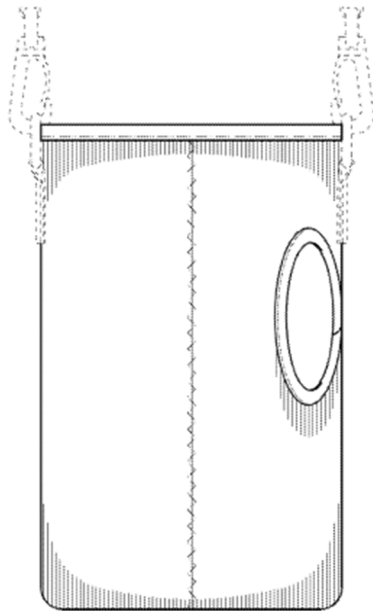

FIG. 3

The '914 Patent

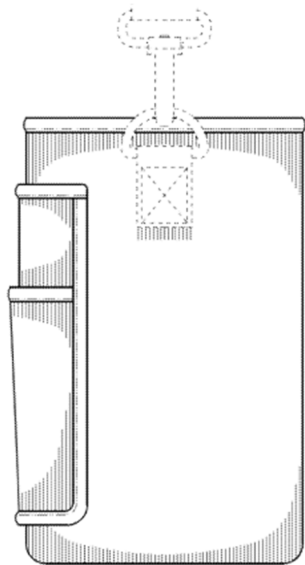

FIG. 4

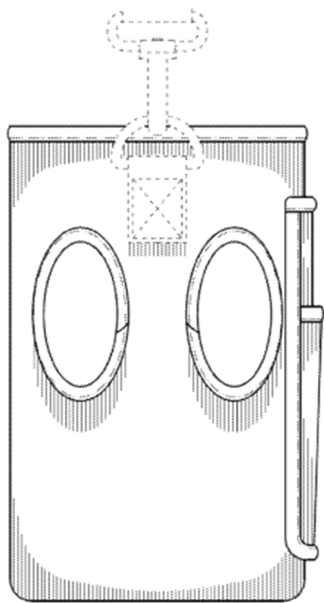

FIG. 5

*The Accused Products
(with Hydrojug Bottle)*



15. The designs of the Accused Products are so similar to the design that is the subject matter of the '914 Patent that customers are likely to be deceived and persuaded to buy the Accused Products thinking they are actually buying products protected by the '914 Patent.

16. Upon information and belief, Defendants had pre-suit and/or pre-infringement knowledge of Hydrojug's '914 Patent.

FIRST CLAIM FOR RELIEF

(Infringement of U.S. Patent No. D889,914)

17. Hydrojug realleges and incorporates the foregoing paragraphs as though fully set forth herein.

18. Defendants have infringed, and continue to infringe the '914 Patent by offering to sell, selling, or importing the Accused Products in this District, and elsewhere in the United States, the design of which is substantially the same as the ornamental design of the '914 Patent.

19. The Accused Products are identical and/or so substantially similar to the design of the '914 Patent as to deceive an ordinary observer.

20. Defendants's actions constitute infringement of the '914 Patent in violation of 35 U.S.C. § 271. Hydrojug has sustained damages and will continue to sustain damages as a result of Defendants's aforementioned acts of infringement.

21. Hydrojug is entitled to recover damages sustained as a result of Defendants's wrongful acts in an amount to be proven at trial.

22. Defendants's infringement of Hydrojug's rights under the '914 Patent will continue to damage Hydrojug's business, causing irreparable harm, for which there is no adequate remedy at law, unless Defendants are enjoined by this Court.

23. Defendants have willfully infringed the '914 Patent, entitling Hydrojug to increased damages under 35 U.S.C. § 284 and to attorneys' fees and costs incurred in prosecuting this action under 35 U.S.C. § 285.

24. Alternatively, Hydrojug is entitled to recover Defendants's total profits from their sale of the Accused Products under 35 U.S.C. § 289.

PRAYER FOR RELIEF

Hydrojug prays for judgment as follows:

- A. A judgment finding Defendants are liable for patent infringement;
- B. An order requiring Defendants to make an accounting for all Accused Products they have made, used, sold, offered for sale, or imported in the United States;
- C. Orders of this Court temporarily, preliminarily, and permanently enjoining Defendants, their agents, servants, and any and all parties acting in concert with any of them, from directly or indirectly infringing in any manner any of the claims of the '914 Patent, pursuant to at least 35 U.S.C. § 283;
- D. An award of damages adequate to compensate Hydrojug for Defendants's infringement of the '914 Patent, in an amount to be proven at trial, or in the alternative, an award of Defendants's total profits under 35 U.S.C. § 289;
- E. An award of treble Hydrojug's damages, pursuant to at least 35 U.S.C. § 284;
- F. A declaration that this is an exceptional case and that Hydrojug be awarded its attorney fees and expenses, pursuant to at least 35 U.S.C. § 285;
- G. An award of Hydrojug's costs in bringing this action, pursuant to all applicable state statutory and common law, including at least 35 U.S.C. § 284;
- H. An award of Hydrojug's attorney's fees, pursuant to all applicable state statutory and common law.
- I. Prejudgment interest, pursuant to at least 35 U.S.C. § 284;
- J. Post-judgment interest, pursuant to at least 28 U.S.C. § 1961(a); and

K. For such other and further relief as the Court deems just and equitable.

DEMAND FOR JURY TRIAL

Hydrojug demands trial by jury on all claims and issues so triable.

DATED: August 1, 2023

By: /s/ Preston P. Frischknecht

Preston P. Frischknecht
(USB #11286) (*pro hac vice*)

preston@projectcip.com

PROJECT CIP

399 N Main, Suite 220

Logan, UT 84321

Telephone: (435) 512-4893

Counsel for Hydrojug