

**IN THE UNITED STATES DISTRICT COURT  
FOR THE WESTERN DISTRICT OF TEXAS  
AUSTIN DIVISION**

**IFPOWER CO., LTD.,**

**Plaintiff,**

**v.**

**ZAGG, INC.,**

**Defendant.**

**Civil Action No. 1:23-cv-01501**

**Jury Trial Demanded**

**PLAINTIFF’S ORIGINAL COMPLAINT**

Plaintiff IFPower Co., Ltd. (“IFPower” or “Plaintiff”) hereby files its Original Complaint against Zagg, Inc. (“Defendant” or “Zagg”) alleging infringement of U.S. Patent Nos. 7,298,361 (the “361 Patent”); and 7,863,860 (the “860 Patent”) (collectively, the “Patents-in-Suit”).

**I. PARTIES**

1. Plaintiff IFPower is a company existing under the laws of Taiwan, with its principal place of business located 1 F., No. 2, Ln. 18, Shuangyuan St., Wanhua Dist., Taipei City 10884, Taiwan (R.O.C.).

2. Upon information and belief, Defendant Zagg, Inc. is a Delaware corporation with its principal places of business located at 910 Legacy Center Way, Suite 500, Midvale, Utah 84047. Upon information and belief, Defendant is authorized to do business in Texas and has an established place of business in this District located at 2901 S. Capital of Texas Highway, Austin, Texas 78746. Defendant can be served by through its registered agent, CT Corporation System, 1108 E. South Union Avenue, Midvale, UT 84047.

**ORIGINAL COMPLAINT**

## II. JURISDICTION AND VENUE

3. This is an action for patent infringement which arises under 35 U.S.C. §§ 271, 281, 284 and 285. This Court has subject matter jurisdiction over this action under 28 U.S.C. §§1331 and 1338(a).

4. This Court has personal jurisdiction over Defendant, and venue is proper in this Court pursuant to 28 U.S.C. §§1391(b), (c), and 1400. This Court has personal jurisdiction over Defendant because, among other things, Defendant has established minimum contacts within the forum such that the exercise of jurisdiction over Defendant will not offend traditional notions of fair play and substantial justice. For example, Defendant has placed products that practice and/or embody the claimed inventions of the Patents into the stream of commerce with the reasonable expectation and/or knowledge that purchasers and users of such products were located within this district.

5. Defendant has an established place of business in this District with a physical address at 2901 S. Capital of Texas Highway, Austin, Texas 78746.

6. In addition, Defendant has sold, advertised, marketed, and distributed products in this district that practice the claimed inventions of the Patents. Defendant derives substantial revenue from the sale of infringing products distributed within the district, and/or expects or should reasonably expect its actions to have consequences within the district and derives substantial revenue from interstate and international commerce.

## III. FACTUAL BACKGROUND

### PATENTS-IN-SUIT

7. IFPower is the owner of all right, title, and interest in and to U.S. Patent No. 7,298,361 (attached as **Exhibit 1**), entitled “Non-Contact Electric Inductance Circuit for Power Source,” issued on November 20, 2007.

**ORIGINAL COMPLAINT**

8. IFPower is the owner of all right, title, and interest in and to U.S. Patent No. 7,863,860 (attached as **Exhibit 2**), entitled “Battery Cover,” issued on January 4, 2011.

TECHNICAL OVERVIEW

9. The '361 Patent is directed to a non-contact inductance circuit for a power source. The inductance circuit converts input alternating current into signals with a high-frequency harmonic vibration. The alternating electric current passes through an amplifier.

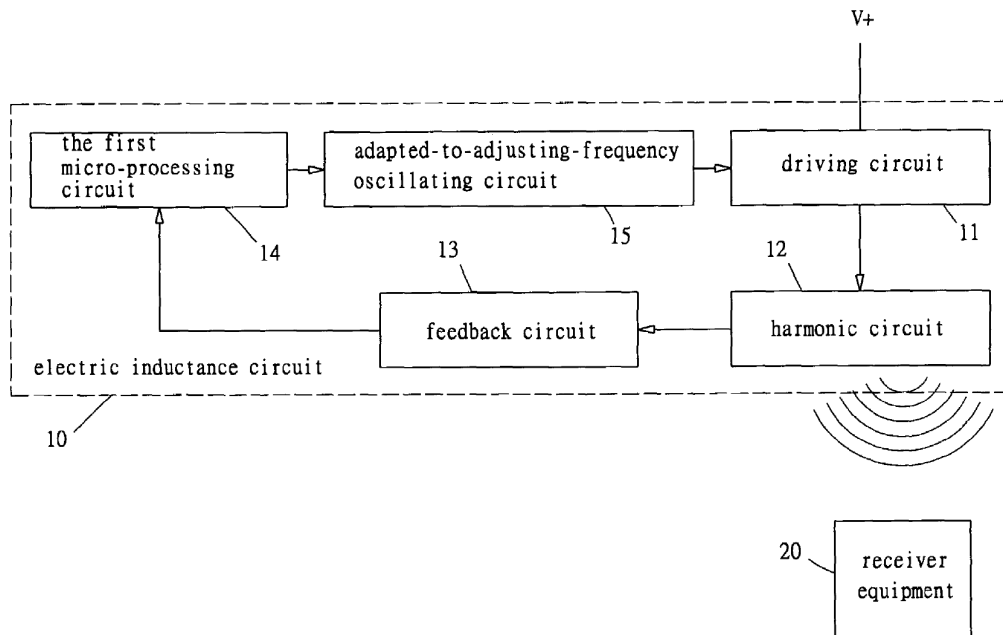

'361 Patent, Fig. 1.

10. During operation, a feedback circuit 13 transmits the voltage or current of the harmonic circuit to a processor to analyze the value of the detected voltage or current.

11. Conventional chargers for electronic devices with rechargeable batteries such as computer mice or smartphones required a physical cable connection between the power supply and the electronic device.

12. Prior art wireless chargers used harmonic vibration energy provided by alternating signals from a coil. That energy is converted into electrical energy by the receiving device. '361

patent, 1:17-24. This is accomplished through interoperations of an internal inductance and an internal capacitor. *Id.*, 1:38-43.

13. Even for inductors and capacitors with a given specification, however, there are practical operating ranges that reflect some differences during operation. As a result, mismatches between characteristics arise which reduce the efficiency of the circuit or require repeated and cumbersome adjustment. *Id.*, 1:43-56.

14. The inventions are thus directed to a nonconventional feedback and adapted-to-adjusting frequency oscillating circuit for physical, wireless chargers.

When in operation, the adapted-to-adjusting-frequency oscillating circuit generates alternating electric current that passes to the harmonic circuit after being amplified through the driving circuit, and the feedback circuit transmits the voltage or the current of the harmonic circuit to the microprocessing circuit that analyses the value of the voltage or the current detected, then the adapted-to-adjusting-frequency oscillating circuit adjusts the frequency of subsequent input alternating electric current, in order that the entire electric inductance circuit for the power source can generate the best harmonic frequency.

*Id.*, 2:5-15.

15. Additionally, in certain embodiments, the inductance circuit is further integrated with a signal processing circuit. In this way, the electric inductance circuit for the power source can be used for radio signal transmission. *Id.* 15 2:16-24.

16. The '860 Patent is directed to wireless charging, whereby a device incorporating the inventions claimed therein can be charged without a cable between the device and charger or removing internal batteries.

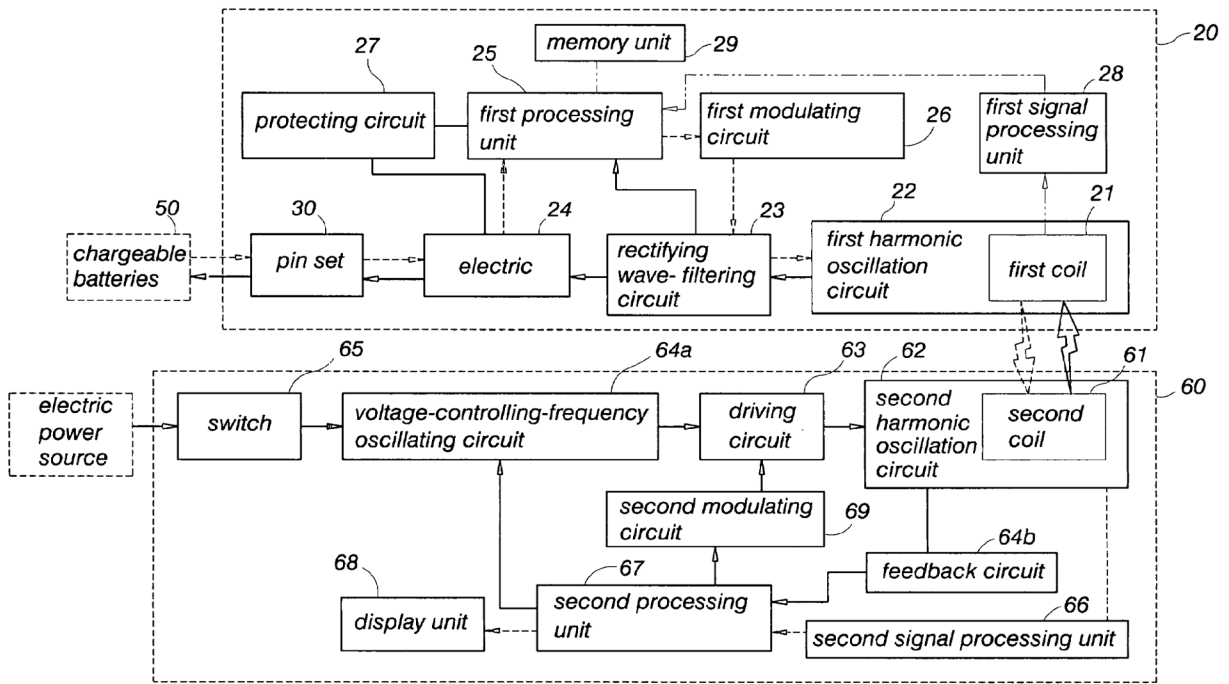
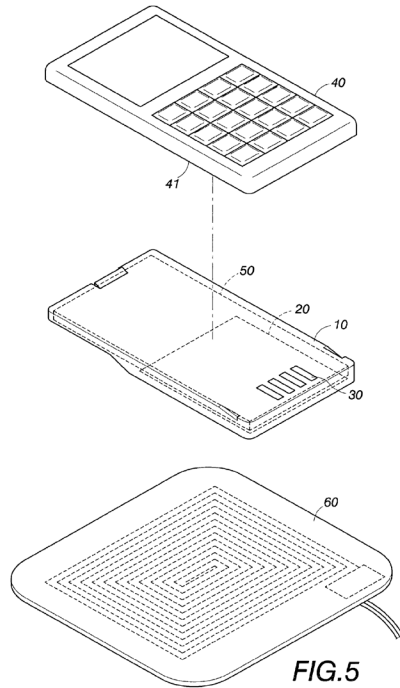

FIG. 4

'860 Patent, Fig. 4.

17. The invention provides a battery cover with circuitry adapted to wireless couple to an RF (radio frequency) emitter for generating electric power for charging a battery by a non-touch induction mode.



'860 Patent, Fig. 5.

18. The '860 Patent claims priority to a Taiwanese application filed on June 29, 2007.

19. The WPC published the Qi low-power specification over two years later, in August 2009.

#### DEFENDANT'S ACTS

20. Defendant is a provider of consumer electronics products offering wireless charging in accordance with certain WPC Qi wireless charging standards.

21. For example, Defendant's wireless chargers comply with the Qi wireless charging standard. Defendant represents compliance to its customers and instructs them how to wirelessly charge using the Qi charging standard.

**ZAGG** Shop By Device Protection Power Keyboards & More New Arrivals Sale Learn Search

Home / Power / 3-in-1 travel charger with MagSafe (2023)

### 3-in-1 travel charger with MagSafe (2023)

ADD TO CART

Portable wireless charging hub compatible with MagSafe

For AirPods, Apple Watch, iPhone 12, iPhone 12 mini, iPhone 12 Pro, iPhone 12 Pro Max, iPhone 13, iPhone 13 mini, iPhone 13 Pro, iPhone 13 Pro Max, iPhone 14, iPhone 14 Plus, iPhone 14 Pro, iPhone 14 Pro Max, MagSafe compatible devices, Magnetic Qi-enabled Devices, iPhone 15, iPhone 15 Plus, iPhone 15 Pro, iPhone 15 Pro Max

Color: Black

**Bundle & Save**  
Enjoy at least 30% off our everyday prices when you buy any two or more products. Savings will be applied in cart to all items not already on sale.

snap+ juice pack mini + \$49.95

<https://www.zagg.com/mophie-universal-wireless-3-in-1-travel-charger-MagSafe-2023>

22. Defendant further instructs and encourages its customers to wirelessly charge their products as it specifies in its documentation.



<https://www.zagg.com/mophie-universal-wireless-3-in-1-travel-charger-MagSafe-2023>

23. On information of belief, Defendant also implements contractual protections in the form of license and use restrictions with its customers to preclude the unauthorized reproduction, distribution, and modification of its products.

24. Moreover, on information and belief, Defendant implements technical precautions to attempt to thwart customers who would circumvent the intended operation of Defendant's products.

#### **IV. PATENT INFRINGEMENT**

##### COUNT I — INFRINGEMENT OF U.S. PATENT NO. 7,298,361

25. Zagg has directly infringed and continues to infringe one or more claims of the '361 Patent in this judicial district and elsewhere in the United States by, among other things, making, having made, importing, using, offering for sale, and/or selling the claimed system and methods of the '361 Patent.

26. At a minimum, Zagg has been, and now is, infringing claims of the '361 Patent by making, importing and/or using infringing systems and/or methods. Zagg infringes at least claim 1 of the '361 Patent.

27. The infringing products include, but are not limited to, Zagg's wireless chargers, including when used in conjunction with Qi-compliant devices (the "'361 Infringing Products"). IFPower alleges that each and every element is literally present in the '361 Infringing Products. To the extent not literally present, IFPower reserves the right to proceed under the doctrine of equivalents.



28. More specifically, Zagg's wireless chargers include a non-contact electric inductance circuit for power source wherein a circuit amplifies an alternating current by an oscillator through a driving circuit and pass to a harmonic circuit.

29. In accordance with the WPC specification, the electric inductance circuit has a feedback circuit, a micro-processing circuit and an adapted-to-adjusting-frequency oscillating circuit integrated with one another.

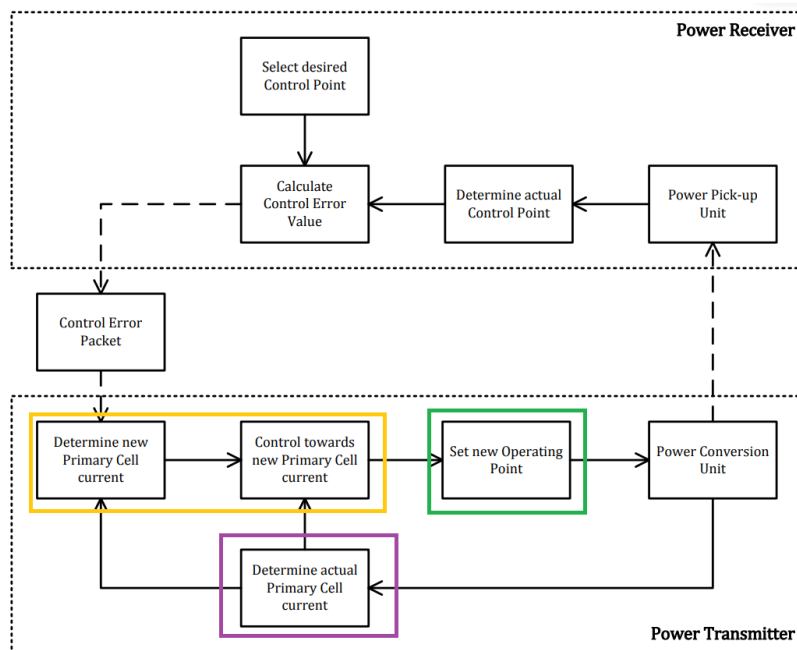

Figure 5-2: Power transfer control loop

<https://cupdf.com/document/wpc-specification.html>

30. The Zagg wireless chargers further include a wireless charging controller.

31. Zagg has indirectly infringed and continues to infringe the '361 Patent by inducing the infringement of the '361 Patent. With knowledge of the '361 Patent, Zagg directs and aids its customers in using the '361 Infringing Products by the provision of its products and software, and related equipment and provision of instruction (including, by way of example, the tutorials, user guides, product guides, and other documentation located at <https://www.zagg.com/user-guides/>) to customers as well as functionality embedded in the '361 Infringed Products (including firmware

and source code) with knowledge that the induced acts constitute patent infringement. When a user of one of the '361 Infringing Products uses MagSafe for wireless charging, the '361 Infringing Product operates in an infringing manner. Zagg possesses specific intent to encourage infringement by its customers.

32. Zagg has contributed to the infringement of, and continues to contribute to the infringement of, one or more claims of the '361 Patent under 35 U.S.C. § 271(c) and/or 271(f), either literally and/or under the doctrine of equivalents, by selling, offering for sale, and/or importing into the United States, the '361 Infringing Products. Zagg knows that the components of the '361 Infringing Products: constitute a material part of the inventions claimed in the '361 Patent; are especially made or adapted to infringe the '361 Patent; and are not staple articles or commodities of commerce suitable for non-infringing use, but rather the Components are used for or in systems that infringe one or more claims of the '361 Patent. The hardware and/or software Components are not a staple article or commodity of commerce because they are specifically designed to perform the claimed functionality. These products are specifically designed for their infringing purpose, namely wireless charging in accordance with the claims of the '361 Patent. Any other use of the hardware and/or software Components would be unusual far-fetched, illusory, impractical, occasional, aberrant, or experimental.

33. IFPower has been damaged as a result of Zagg's infringing conduct. Zagg is thus liable to IFPower in an amount that adequately compensates it for Zagg's infringements, which, by law, cannot be less than a reasonable royalty, together with interest and costs as fixed by this Court under 35 U.S.C. § 284.

COUNT II — INFRINGEMENT OF U.S. PATENT NO. 7,863,860

34. Zagg has directly infringed and continues to infringe one or more claims of the '860 Patent in this judicial district and elsewhere in the United States by, among other things, making, having made, importing, using, offering for sale, and/or selling the claimed system and methods of the '860 Patent.

35. At a minimum, Zagg has been, and now is, infringing claims of the '860 Patent by making, importing and/or using wireless chargers that comply with the Qi wireless standard. Zagg's chargers are designed to interact with a battery cover of the type claimed in the '860 Patent. Zagg infringes at least claim 1 of the '860 Patent.

36. Zagg's infringing products include, but are not limited to, Zagg's 3 in 1 travel charger, snap + juice pack mini, powerstation wireless stand and other product lines that are compliant with or use the Qi wireless charging protocol (the "'860 Infringing Products"). The '860 Infringing Products are specifically designed to interoperate with a battery cover as claimed. Zagg puts the infringing system into use as a whole. On information and belief, Zagg tests the '860 Infringing Products to ensure that battery covers meeting specified criteria are used in conjunction with its products.

37. Zagg instructs its users how to perform wireless charging with their devices using the '860 Infringing Products.

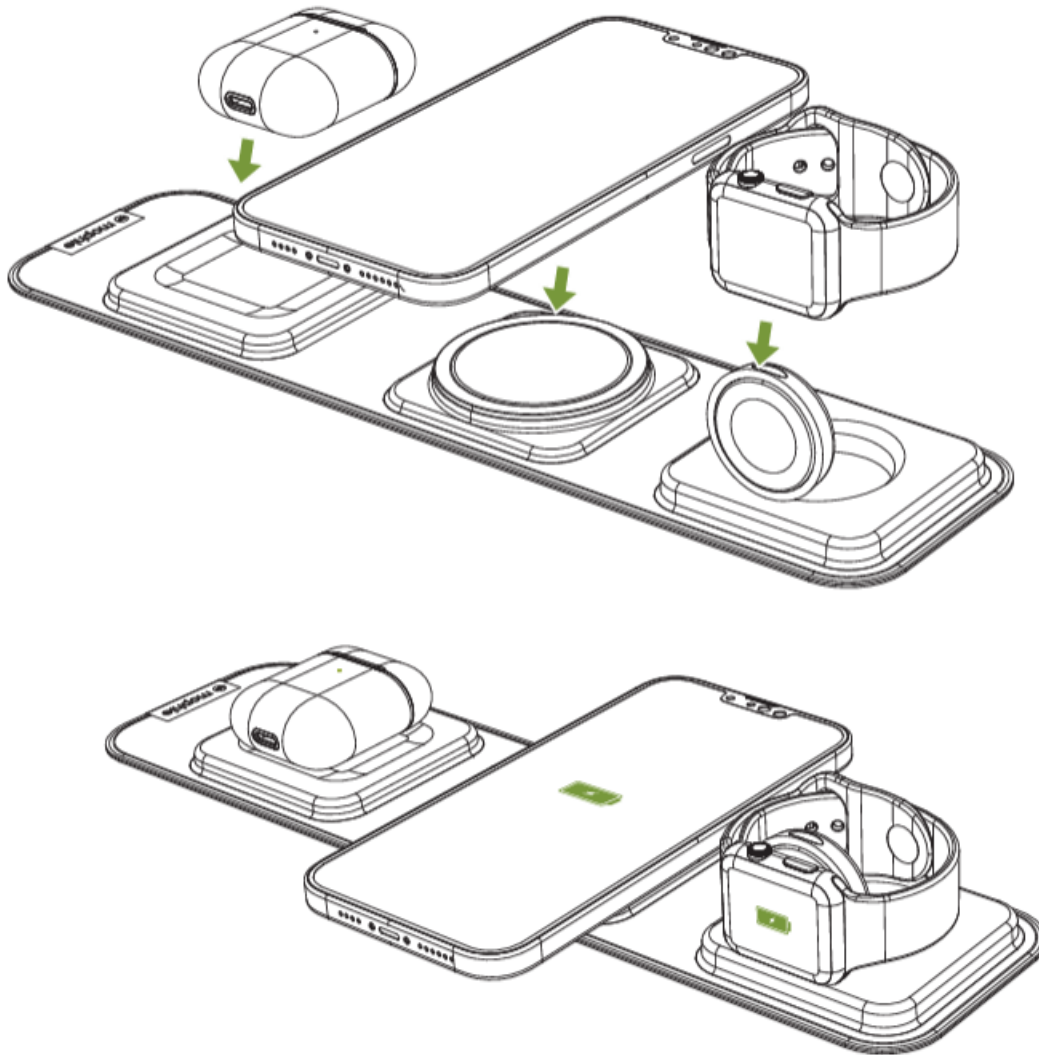

Mophie 3-in-1 Travel Charger with Magsafe User Guide, p. 4.

38. In accordance with the WPC specification, devices interacting with the '860 Infringing Products includes a rectifying wave filtering circuit.

Figure 4. Functional block diagram for an Extended Power Profile Power Receiver

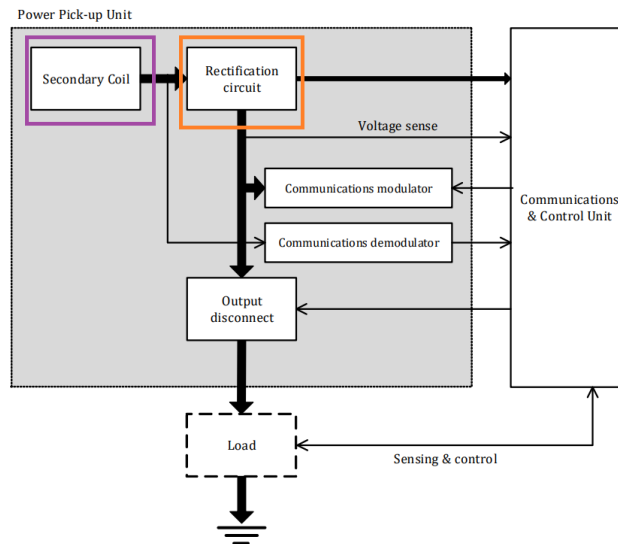

<https://www.wirelesspowerconsortium.com/data/downloadables/3/3/2/3/qj-v13-public.zip>

39. IFPower alleges that each and every element is literally present in the '860 Infringing Products. To the extent not literally present, IFPower reserves the right to proceed under the doctrine of equivalents.

40. Zagg has indirectly infringed and continues to infringe the '860 Patent by inducing the infringement of the '860 Patent. With knowledge of the '860 Patent, Zagg directs and aids its customers in using the '860 Infringing Products by the provision of its products and software, and related equipment and provision of instruction (including, by way of example, the tutorials, user guides, product guides, and other documentation located at <https://www.zagg.com/user-guides/>) to customers as well as functionality embedded in the '860 Infringed Products (including firmware and source code) with knowledge that the induced acts constitute patent infringement. When a user of one of the '860 Infringing Products charges the phone or watch, the '860 Infringing Product operates in an infringing manner. Zagg possesses specific intent to encourage infringement by its customers.

41. Zagg has contributed to the infringement of, and continues to contribute to the infringement of, one or more claims of the '860 Patent under 35 U.S.C. § 271(c) and/or 271(f), either literally and/or under the doctrine of equivalents, by selling, offering for sale, and/or importing into the United States, the '860 Infringing Products. Zagg knows that the components of the '860 Infringing Products: constitute a material part of the inventions claimed in the '860 Patent; are especially made or adapted to infringe the '860 Patent; and are not staple articles or commodities of commerce suitable for non-infringing use, but rather the Components are used for or in systems that infringe one or more claims of the '860 Patent. These products are specifically designed for their infringing purpose, namely wireless charging in accordance with the claims of the '860 Patent. The hardware and/or software Components are not a staple article or commodity of commerce because they are specifically designed to perform the claimed functionality. Any other use of the hardware and/or software Components would be unusual far-fetched, illusory, impractical, occasional, aberrant, or experimental.

42. IFPower has been damaged as a result of Zagg's infringing conduct. Zagg is thus liable to IFPower in an amount that adequately compensates it for Zagg's infringements, which, by law, cannot be less than a reasonable royalty, together with interest and costs as fixed by this Court under 35 U.S.C. § 284.

#### **V. WILLFULNESS**

43. Zagg was provided notice of IFPower's claims at least by way of the Original Complaint filed against it.

44. Zagg acted and continues to act with knowledge of the Patents-in-Suit despite an objectively high likelihood that its actions constituted infringement of IFPower's valid patent rights.

45. This objectively defined risk was either known or so obvious that it should have been known to Zagg. IFPower seeks enhanced damages pursuant to 35 U.S.C. §284.

#### **VI. JURY DEMAND**

46. IFPower demands a trial by jury of all matters to which it is entitled to trial by jury, pursuant to FED. R. CIV. P. 38.

#### **VII. PRAYER FOR RELIEF**

47. WHEREFORE, Plaintiff IFPower prays for judgment and seeks relief against Defendant as follows:

- a. Judgment that one or more claims of the Patents-in-Suit have been infringed, either literally and/or under the doctrine of equivalents;
- b. Award Plaintiff past and future damages together with prejudgment and post-judgment interest to compensate for the infringement by Defendant of the Patents-in-Suit in accordance with 35 U.S.C. §284, and increase such award by up to three times the amount found or assessed in accordance with 35 U.S.C. §284;
- c. That the Court declare this an exceptional case and award Plaintiff its reasonable attorney's fees and costs in accordance with 35 U.S.C. § 285; and
- d. That Plaintiff be granted such other and further relief as the Court may deem just and proper under the circumstances.

Dated: December 11, 2023

Respectfully submitted,

/s/ Andrew G. DiNovo

Andrew G. DiNovo

Texas State Bar No. 00790594

Michael D. French

Texas State Bar No. 24116392

**DiNovo Price LLP**

7000 N. MoPac Expressway, Suite 350

Austin, Texas 78731

Telephone: (512) 539-2626

Telecopier: (512) 727-6691

[adinovo@dinovoprice.com](mailto:adinovo@dinovoprice.com)

[mfrench@dinovoprice.com](mailto:mfrench@dinovoprice.com)

**ATTORNEYS FOR PLAINTIFF  
IFPOWER**

**ORIGINAL COMPLAINT**