

**IN THE UNITED STATES DISTRICT COURT
FOR THE EASTERN DISTRICT OF MICHIGAN**

DARTON ARCHERY, LLC,

Plaintiff,

v.

MARTIN OUTDOOR, LLC
d/b/a “Martin Archery”

and

JEFFERSONVILLE GEORGIA LLC,
d/b/a “Obsession Bows”

Defendants.

Case No.:

JURY TRIAL DEMANDED

VERIFIED COMPLAINT

Plaintiff DARTON ARCHERY, LLC, by its attorneys, EDWARDS MAXSON MAGO & MACAULAY LLP, and for its Verified Complaint against MARTIN OUTDOOR, LLC and OBSESSION BOWS, LLC., states:

PARTIES

1. At all relevant times hereto, Plaintiff DARTON ARCHERY, LLC (“**Plaintiff**” or “**Darton**”) is and was a limited liability company organized under the laws of the State of Georgia, with its principal place of business located in Canton, Georgia and an additional facility located in Hale, Michigan where much of

Darton's research and development is done. The sole member of Plaintiff is Randy Kitts, a citizen and resident of the State of Georgia.

2. Defendant MARTIN OUTDOOR, LLC. d/b/a Martin Archery ("**Martin**") is a limited liability company organized in the State of Delaware with its principal place of business located at 3301 E Isaacs Ave, Walla Walla, WA 99362.

3. Defendant JEFFERSONVILLE GEORGIA LLC, d/b/a "Obsession Bows," is a limited liability company organized in the State of Delaware with its principal place of business located at 118 Magnolia St N Jeffersonville, GA, 31044-5406 ("**Obsession**"). Obsession was previously organized as "Obsession Bows, LLC" but the entity name was changed to "Jeffersonville Georgia LLC," prior to commencement of this action.

JURISDICTION AND VENUE

4. This action arises, at least in part, under the patent laws of the United States, Title 35 of the United States Code (the "**Patent Claims**"). This Court, therefore, has subject matter jurisdiction of the Patent Claims under 28 U.S.C. §§ 1331 and 1338(a).

5. This action arises, at least in part, under the trademark laws of the United States, Title 15 of the United States Code (the "**Trademark Claims**").

This Court, therefore, has subject matter jurisdiction of the Trademark Claims under 28 U.S.C. §§ 1331 and 1338(a).

6. This Court has supplemental subject matter jurisdiction over the remaining claims pursuant to 28 U.S.C. § 1367(a) because they are so related to claims in the action within such original jurisdiction that they form part of the same case or controversy.

7. This Court would also have subject matter jurisdiction pursuant to 28 U.S.C. § 1332 (a) of all claims other than the Patent Claims and Trademark Claims as the citizenship of Plaintiff is diverse from the citizenship of each defendant, and the amount in controversy exceeds \$75,000 exclusive of interest and costs.

8. Personal jurisdiction by this Court over both Defendants is proper pursuant to MCL 600.711 because Defendants consented to jurisdiction over this dispute in the State of Michigan. Further, personal jurisdiction by this Court over Defendant is proper pursuant to 600.715 because Defendants both transacted business in the State of Michigan and entered into a contract for services to be performed or for materials to be furnished in the State of Michigan.

9. Personal jurisdiction by this Court over Defendant Martin is also proper pursuant to MCL 600.715 because Defendant transacted business in the State

of Michigan, including selling at least one product with unauthorized use of Plaintiff's federally registered trademark. See **Exhibit A** ("Sales Receipt").

10. In further support of personal jurisdiction over Defendant Obsession, Obsession also sells multiple bow and archery products to at least one Archery dealer in Michigan, "Ground Zero Archery," located in St. Joseph and Niles, Michigan, as shown below:



"Nothing clears a troubled mind like shooting a bow" - Fred Bear

For the Love of Archery

Welcome to Ground Zero Archery - where customer service is our top priority! We pride ourselves on having an unmatched depth of Archery knowledge. If it is Archery we sell it, teach it, coach it, and compete in it. Where will your Archery adventure take you?...Compound,

Brands We Carry



9/7/2023 Ground Zero Archery Website, available at <https://www.groundzeroarchery.com/> (edited for size and to remove unnecessary images), last visited 09/09/2023.

11. Likewise, Defendant Martin also contracts or otherwise avails itself of the benefits of the State of Michigan through multiple authorized dealers in this district, including Schupbach's Sporting Goods, in Jackson Michigan.

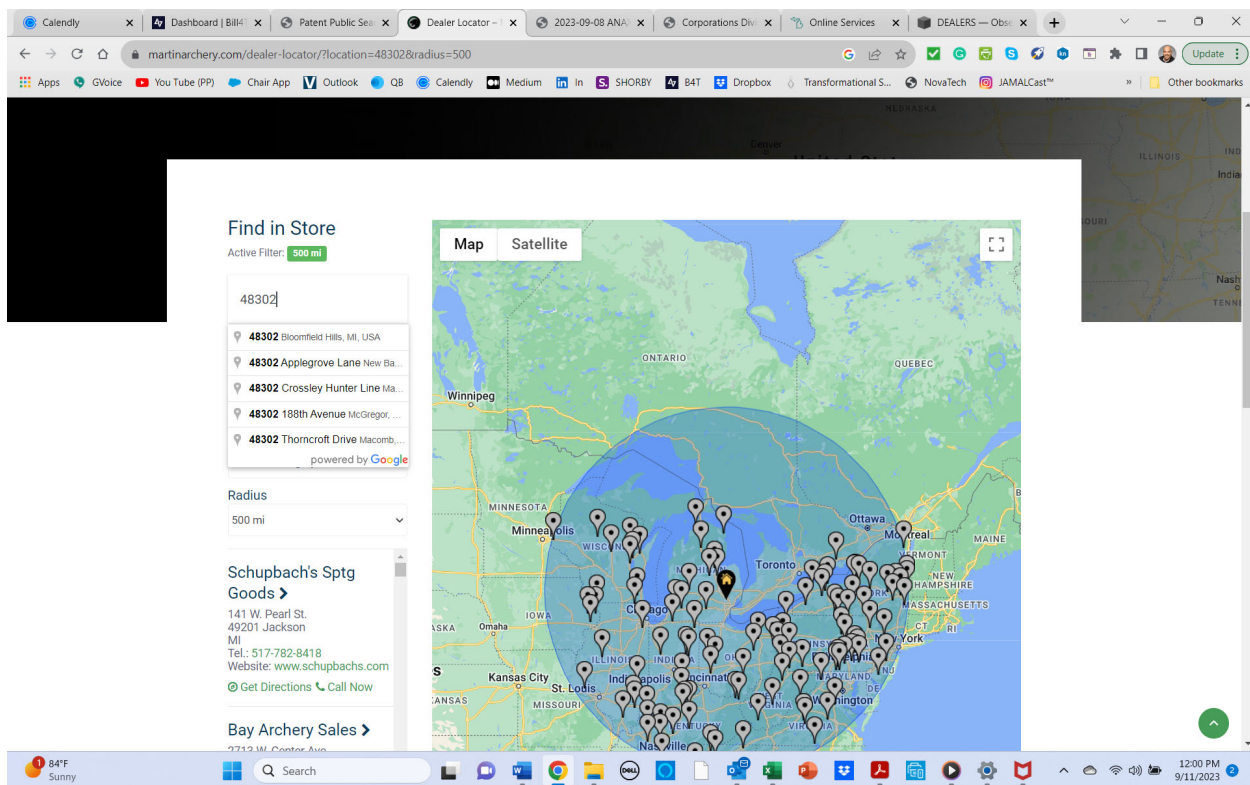

12. In further support of personal jurisdiction over Defendant Obsession, upon information and belief, Obsession sells hundreds or more of such products, and directs even more infringing advertising at consumers in this district through its web and marketing efforts.

13. Venue is proper in this district pursuant to 28 U.S.C. § 1391 because a substantial part of the events or omissions giving rise to the Complaint occurred in this district, and Plaintiff and Defendant Martin consented to venue in the State of Michigan.

BACKGROUND FACTS

Darton Archery

14. Until December 2020, the “Darton Archery” brand, including its intellectual property rights, were owned by Darton’s predecessor in interest, Darton Inc., and its sole shareholder, Rex Darlington (“**Darlington**”). In fact, Darlington is the first named inventor on nearly all of Darton’s patents.

15. On December 21, 2020, Darlington sold all or substantially all of Darton Inc.’s assets to Darton.

16. As of the filing of this Complaint, Darlington is an employee of Darton.

17. As of the filing of this Complaint, Darton is the record owner of the following relevant intellectual property assets:

- a. United States Patent No. 6,990,970, entitled “Compound Archery Bow” (1/31/2006) (the “**970 Patent**”), including the application from which it derives and all continuations, divisional or continuations-in-part thereof.

- b. U.S. Patent No. 9,121,658, entitled “Compound Archery Bow with Synchronized Cams and Draw Stop,” (9/1/2015) (the “**’658 Patent**”) including the application from which it derives and all continuations, divisional or continuations-in-part thereof.
- c. U.S. Trademark Registration No. 4,299,445 for the mark “DUALSYNC” (3/5/2013) (the “**DUALSYNC Mark**”), with exclusive rights of use in IC 008 and US 023 028 044, including for goods and services such as “Archery Bows.”

The ’970 Patent

18. On January 31, 2006, the United States Patent and Trademark Office (“USPTO”) duly and legally issued the ’970 Patent entitled “Compound Archery Bow,” to Rex F. Darlington (“Darlington”). A true and correct copy of the ’970 patent is attached as **Exhibit B** (“’970 Patent”) and incorporated herein by reference.

19. The ’970 Patent relates to and discloses a compound archery bow with pulleys at the ends of the bow limbs that control the force/draw characteristics of the bow.

20. Claim 1 of the ’970 patent recites:

1. A compound archery bow that includes:
a handle having projecting limbs,

a first pulley mounted on a first of said limbs for rotation around a first axis,

a second pulley mounted on a second of said limbs for rotation around a second axis, and

bow cable means including a bowstring cable extending from bowstring let-out grooves on said first and second pulleys,

a first cable extending from a cable take-up groove on said first pulley to second cable let-out means on said second pulley, and

a second cable extending from a cable take-up groove in said second pulley to first cable let-out means on said first pulley

such that draw of said bowstring cable away from said handle lets out bowstring cable from said let-out grooves on said first and second pulleys, rotates on said first and second pulleys around said axes, and lets out portions of said first and second cables from said first and second cable let-out means on said first and second pulleys,

wherein at least one of said bowstring let-out grooves and/or at least one of said cable take-up grooves is non-circular.

21. Figure 4 of the '970 Patent is a dual cam bow in accordance with

one of the preferred embodiments of the invention:

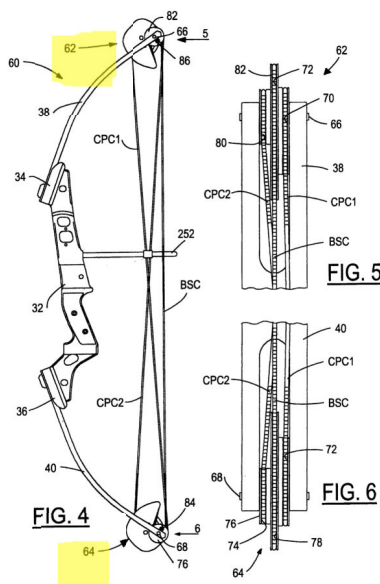

22. Figures 5 and 6 are views of the cams taken from views 5 and 6 in Figure 4 above.

The '658 Patent

23. On September 1, 2015, the USPTO duly and legally issued the '658 Patent entitled "Compound Archery Bow with Synchronized Cams and Draw Stop," to Darlington. A true and correct copy of the '658 Patent is attached as **Exhibit C** ("'658 Patent") and incorporated herein by reference.

24. The '658 Patent relates to and discloses a compound archery bow having a pulley assembly with a draw stop on a take-up cam that may be engaged against a power cable limiting rotation of the pulley at full draw, thereby preventing a cam-lock situation.

25. Claim 1 of the '658 Patent recites:

444 A compound archery bow that includes:

a bow handle;

a limb projecting from the bow handle; and

a pulley assembly coupled to the limb for rotation around an axis, and including:

a bowstring cam including a bowstring track in a bowstring plane,

a let-out cam carried by the bowstring cam and including a let-out track in a let-out plane spaced apart from the bowstring plane,

an arcuately-shaped first take-up cam arcuately adjustably coupled to the bowstring cam and including a first take-up track in a take-up plane, and

a first draw stop at one end of the first take-up cam.

26. Figure 1 of the '658 Patent is a compound archery bow in accordance with one of the preferred embodiments of the invention:

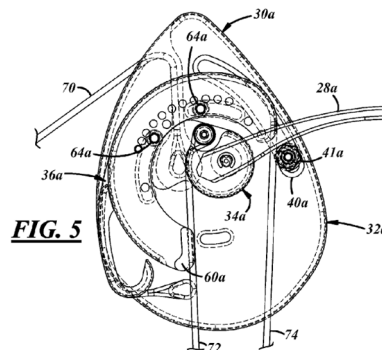
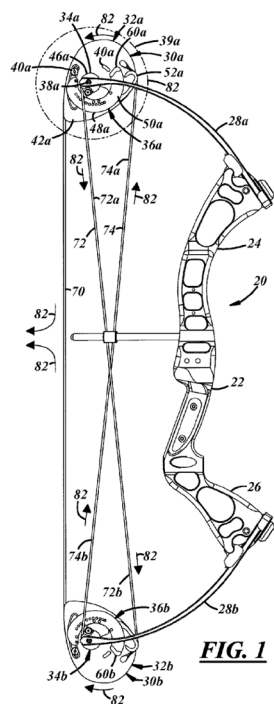

27. Figure 5 is an enlarged, fragmentary view of a pulley assembly in a fully drawn condition with engagement of a draw stop with a power cable.

28. Darton is the assignee of all right, title and interest in the '970 Patent and the '658 Patent (collectively, "Patents-in-Suit"), including all rights to enforce and prosecute actions for infringement and to collect damages for all relevant times against infringers of the Patents-in-Suit. Accordingly, Darton

possesses the exclusive right and standing to prosecute the present action for infringement of the Patents-in-Suit by Defendants.

29. Darton practices the inventions claimed in the Patents-in-Suit.

30. Specifically, Darton develops and manufactures compound archery bows that train the power cable or cable segments around grooves in the cam or control wheel at the end of the bow limb rather than anchor them to the bow limb itself. An example of such bows can be seen on <https://dartonarchery.com/compound-bows/> (last visited on 9/13/2023).

Martin Outdoor

31. In the late summer of 2007, the owner of Darton's predecessor in interest, Darton Inc. via Darlington, and Defendant Martin entered into a License Agreement with an effective date of July 1, 2007, a copy of which is attached hereto as **Exhibit D** (the "2007 License").

32. Pursuant to the 2007 License, Defendant Martin received an exclusive, worldwide license to manufacture, have manufactured, use, sell, import, and export archery bows practicing the invention ("Licensed Product") claimed in the '970 Patent, and certain other rights. Ex. D, § 1.

33. In October 2012, the 2007 License was ostensibly terminated by Darlington for nonpayment of earned royalties and fees. *See Exhibit E* (10/31/2012 G. Palmer Letter to Martin Archery).

34. Subsequently, in July 2017, Darlington and Martin began a project whereby Darlington was hired by Martin to perform certain professional services about which a dispute over compensation and other terms arose.

35. In March 2018, Darlington filed suit against Martin and related parties in Iosco County Circuit Court (the “State Case”). The State Case was assigned case number 18-1060-CK, before the Honorable Laura A. Frawley.

36. In the State Case, the parties thereto asserted various contract and related claims and counterclaims, including Breach of Contract, Promissory Estoppel, Quantum Meruit and Fraud, and referred multiple times to Darlington and/or Darton Inc’s patent technology and prior license agreements of the same, including in their complaint and answer documents; examples of which are excerpted below (copies are available upon request and will be submitted with anticipated motion practice):

18. Martin admits only that it timely paid the bills, as submitted by Plaintiff, for services allegedly rendered by Plaintiff, until on or about November 2017. However, Plaintiff's bills lacked sufficient information and detail and, upon information and belief, Martin may have been billed for "research and development" related to Plaintiff's interests and not the interests of Martin. Further, contrary to any agreement of the parties, though Plaintiff was to develop a "cam" specifically for Martin (for which Martin would have no responsibility to pay royalties to any person or party), Plaintiff and/or Plaintiff's owner, Rex Darlington (hereinafter, "Darlington"), later advised that the cam at issue was subject to patent and/or other intellectual property rights held by Plaintiff and/or Darlington. Martin denies as untrue any remaining allegations in this paragraph.

2018/07/24 Martin's Answer and Affirmative Defenses at ¶ 18 (emphasis added)

21. Martin admits only that it denied payment of certain of Plaintiff's invoices because of the following actions by Plaintiff: (a) submitting invoices to Martin that included numerous entries of services rendered unrelated to the anticipated Martin project; (b) refusing reasonable requests by Martin to submit invoices with sufficient information to determine whether the time and costs of the services rendered were justified; (c) designing a cam for Martin that was subject to Plaintiff and/or Darlington's patent and/or intellectual property rights in contravention of the parties' anticipated agreement; (d) refusing to turn over the CAD files owed to Martin; and (e) reneging on its agreement with Martin under which Martin would sell

Id. at ¶ 21 (emphasis added).

37. To compromise this dispute between Darlington (and Darton, Inc.) and Martin, the parties to the State Case entered into a settlement agreement on November 30, 2018, whereby, in exchange for sufficient consideration, Martin

agreed to take an additional license to the '970 Patent (“the **2018 Martin License**”), and Martin agreed to:

completely releases, acquits and forever discharges Darton and all of Darton’s officers, directors, shareholders, trustees, beneficiaries, present and/or former employees, independent contractors, agents, attorneys, accountants, heirs, parents, subsidiaries, heirs, successors and assigns from **any and all claims, defenses, actions, causes of action (whether in tort, contract or otherwise and whether they be civil, criminal and/or administrative)**, demands, rights, damages, costs, attorney or other fees, loss of service, expenses, penalties and compensation whatsoever whether known or unknown which **they now have, will have, or may hereinafter accrue on account of, or in any way arising out of, or as the result of, or in any manner related to the facts and circumstances a) underlying the subject Litigation and b) concerning any transaction between Martin and Darton from the beginning of time through the execution of this Agreement.**

Exhibit F (“11/30/2018 Darton/Martin Settlement Agreement”).

38. The 2018 Martin License requires Defendant Martin to pay royalties, due and payable quarterly within 30 days after the end of each January, April, July, and October, for each Licensed Product, sold, transferred, or exchanged.

Exhibit G (2018 Martin License) §§ 2 and 3.

39. The royalties due under the 2018 Martin License consists of a royalty in the amount \$17.00 per Licensed Product; or, alternatively, for Licensed Products “which are cam assemblies used on licensed product sold and are separately sold as replacement components, LICENSEE shall pay \$8.50 (US) per cam or \$17.00 (US) per pair of cams.” Ex. G (2018 Martin License), Appx. A.

40. Additionally, the 2018 Martin License requires Martin to sell Licensed Products in the following minimum quantities:

For the year 2019: 1,000

For the year 2020: 1,750

For the year 2021: 2,500

“The required minimum annual unit sales of the Licensed Product for the year 2021 shall be the same for all future years in which this Licensing Agreement is in effect.”

Id.

41. Furthermore, if Martin “does not meet the minimum sales requirement in any particular year, LICENSEE may make payment to LICENSOR in the same amount as would have been required if annual unit sales equaled the required minimum amount.” *Id.*

42. The royalty payments due under the 2018 Martin License are subject to inflation/deflation adjustments at the end of 2019 and for each three years thereafter. Ex. G, § 12.2.

43. Defendant was notified of one or more inflation adjustments under the Agreement.

44. The 2018 Martin License further provides that interest shall accrue on any unpaid royalties at a rate of 12% per annum. Ex. G, § 6.

45. Pursuant to the 2018 Martin License, Martin is required to render, at the end of each calendar quarter, a written statement regarding the number of Licensed Products sold during the quarter. Ex. G, § 4.

46. During the entire term of the 2018 Martin License, Martin did not provide any reports regarding its sales of Licensed Products, despite being required to do so on at least a quarterly basis. *See id.*

47. On July 9, 2021, Martin (via counsel) sent a letter to Darton:

i. promising to pay all outstanding royalties as of that date

(**Exhibit H** at 1),

Martin Outdoors acknowledges that it owes payments to Darton Archery for 2020. Based on the information available to me, it appears that Martin Outdoors has already made quarterly payments of \$4,484.00 for 2020, and a partial payment of \$12,633.00 related to the 2020 minimum. Martin Outdoors will also provide a report and payment for the first and second quarter sales in 2021. Martin Outdoors regrets that the payments have been delayed and will tender payments shortly.

ii. promising to provide quarterly reporting (*id.*), and

Martin Outdoors acknowledges that it owes payments to Darton Archery for 2020. Based on the information available to me, it appears that Martin Outdoors has already made quarterly payments of \$4,484.00 for 2020, and a partial payment of \$12,633.00 related to the 2020 minimum. Martin Outdoors will also provide a report and payment for the first and second quarter sales in 2021. Martin Outdoors regrets that the payments have been delayed and will tender payments shortly.

iii. stating that it was terminating the license (*id.* at 2); and

Appendix A of the License Agreement. Appendix A of the License Agreement provides that Martin Outdoors may terminate the License Agreement if minimum annual unit sales are not met. Accordingly, Martin Outdoors is hereby providing notice to Darton Archery of the termination of the License Agreement, effective today. Once again, Martin Outdoors will pay to Darton Archery those royalties already owing for the year 2020, and will report and pay royalties owing upon sales by Martin Outdoors of Licensed Product during the first two quarters of 2021 and through the date of this letter, but not thereafter. As a showing of good faith, Martin Outdoors will pay to Darton Archery the full amount of the 2020 minimum annual royalty (1,750 units x \$17.00 per bow, or \$29,750.00) even though Martin Outdoors is terminating the License Agreement by reason of not having sold 1,750 units of License Product in 2020. Based on the previous payments related to 2020, that leaves a balance of \$12,633.00.

- iv. contesting the validity of the '970 Patent, in contravention of § 7 of the 2018 Martin License.

The decision by Martin Outdoors to terminate the License Agreement is also influenced by Martin Outdoors' determination that it does not require a license under the '970 Darlington patent to sell the NXT-series cam system products on which it has been previously been paying royalties to Darton Archery under the License Agreement.

It is the position of Martin Outdoors that dependent claims 2, 8, 10 and 11 are also anticipated by, and therefore invalidated by, the Martin '841 patent.

Exhibit H, 7/9/2021 M. Glazer Letter to D. Kielczewski (emphasis added).

48. Despite Martin's July 9, 2021, written promise to "pay to Darton Archery those royalties already owing for the year 2020, and ... report and pay royalties owing upon sales by Martin Outdoors of Licensed Product during the first two quarters of 2021 and through the date of this letter, but not thereafter," it failed to make any payments or tender any such reports.

49. In fact, the last payment Darton received from Defendant Martin for any reason, including pursuant to the 2018 Martin License, was received on April 6, 2021, in the amount of \$12,633.00.

50. Martin never sent any of the required reports to Darton, including the promised "report[s] ... owing upon sales by Martin Outdoors of Licensed Product during the first two quarters of 2021 and through the date of this letter...."

Id. at 2.

51. Accordingly, Martin's July 9, 2021, assertion that "Martin Outdoors' unit sales of Licensed Product under the License Agreement during 2020

did not meet the annual minimum units of 1,750 compound bows set forth in Appendix A of the License Agreement, and it is already clear that Martin Outdoor's [sic] annual unit sales for 2021 of 'Licensed Product' will fall far short of the 2,500 minimum unit sales requirement..." was and remains unsubstantiated. *See id.*

52. Martin continues to make, use, sell and offer for sale Licensed Products as that term is defined in the 2018 License Agreement.

53. On or around June 10, 2020, Martin acquired Obsession Bows, either by acquisition of all or substantially all of Obsession Bows' equity interests, or by acquiring all or substantially all of its assets. *See Exhibit I* ("6/2/2020 P. Robinson Ltr to R. Darlington"); *see also* <https://insidearchery.com/martin-archery-acquires-obsession-bows/>, last visited 08/23/2023.

54. Martin is currently operating the business formerly known as Obsession Bows.

Trademark Usage

55. Despite not holding a valid trademark license to use the DUALSYNC Mark, Martin markets and advertises its products as having "Dual Sync Technology" on its website, packaging, and marketing materials in connection with at least the following Archery Bow products, as of the date of this filing:

a. Legend

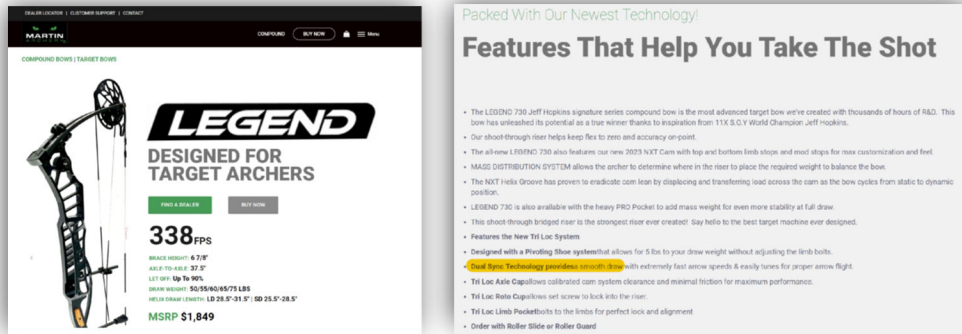

Excerpt from <https://martinarchery.com/compound-bows/legend730/> (last visited 9/9/2023)

b. NXT 40



Excerpt from <https://martinarchery.com/compound-bows/nxt40/> (last visited 9/9/2023)

c. NXT 8

Packed With Our Newest Technology!

Features That Help You Take The Shot

- NXT 8 is for the Long Draw Target Archer or the Target Archer that just craves that Long Brace Height Forgiveness
- The NXT features our new 2023 NXT Cam with top and bottom limb stops and mod stops for max customization and feel.
- **Dual Sync Technology** provides a smooth draw and extremely fast arrow speed, and easily tunes for proper arrow flight.
- RRAD Weight Distribution System allows the archer to distribute weight individually throughout the riser by using a light or heavy weight adjustable system.
- Features the New Tri Loc System
- Designed with a **Pivoting Shoe system** that allows for 5 lbs to your draw weight without adjusting the limb bolts.
- **Dual Sync Technology** provides a smooth draw, extremely fast arrow speeds & easily tunes for proper arrow flight.
- **Tri Loc Axle Cap** allows calibrated cam system clearance and minimal friction for maximum performance.
- **Tri Loc Roto Cup** allows set screw to lock into the riser.
- **Tri Loc Limb Pocket** bolts to the limbs for perfect lock and alignment
- Order with Roller Slide or Roller Guard

Excerpt from <https://martinarchery.com/compound-bows/nxt8/> (last visited 9/9/2023)

d. ANAXX 38

COMPOUND BOWS | TARGET BOWS



ANAXX 38

DESIGNED FOR TARGET ARCHERS

[FIND A DEALER](#) [BUY NOW](#)

328 FPS

BRACE HEIGHT: 7"
AXLE-TO-AXLE: 38"
LET OFF: Up To 90%
DRAW WEIGHT: 50/55/60/65/70 LBS
HELIX DRAW LENGTH: LD 29"-32" | SD 26"-29"

MSRP \$1,429

Packed With Our Newest Technology!

Features That Help You Take The Shot

- Features the New Tri Loc System
- Designed with a **Pivoting Shoe system** that allows for 5 lbs to your draw weight without adjusting the limb bolts.
- **Balanced Bow Technology** allows for proper grip location, parallel limbs & weight distribution. The most adjustable & stable shooting platform ever designed.
- **Dual Sync Technology** provides a smooth draw, extremely fast arrow speeds & easily tunes for proper arrow flight.
- **Tri Loc Axle Cap** allows calibrated cam system clearance and minimal friction for maximum performance.
- **Tri Loc Roto Cup** allows set screw to lock into the riser.
- **Tri Loc Limb Pocket** bolts to the limbs for perfect lock and alignment
- Utilizes **Dual Sync Cam Technology** with **String Stop** for fine-tuning to match your individual shooting style & draw length.
- Long Draw & Short Draw Helix Cams allow for 89%+ efficiency at every draw length in a 6' range.
- Customized tuning available with the use of **RRAD Balanced Bow Technology**.
- RRAD Weight Distribution System allows the archer to distribute weight individually throughout the riser by using a light or heavyweight adjustable system.

Left and Right-Hand Option is Currently Available.

Excerpt from <https://martinarchery.com/compound-bows/anax-38-bow/> (last visited 9/9/2023)

e. ANAXX 3D

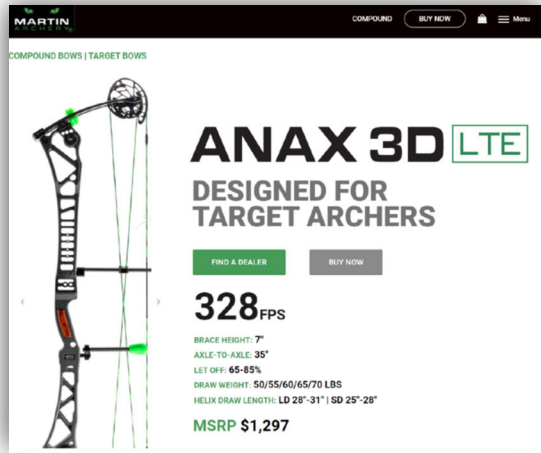

Excerpt from <https://martinarchery.com/compound-bows/anax-3d-lte-bow/> (last visited 9/9/2023)

f. MAXX 33

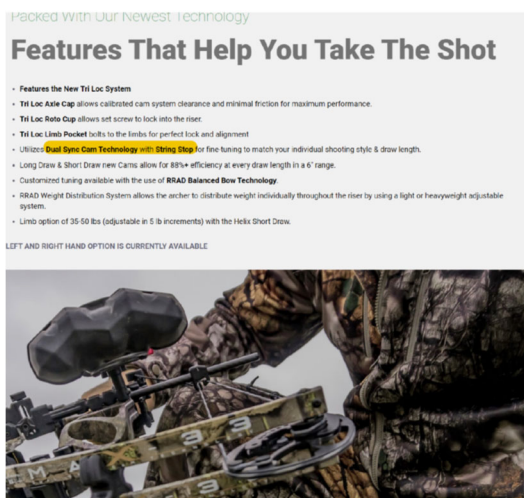

Excerpt from <https://martinarchery.com/compound-bows/maxx-33-bow/> (last visited 9/9/2023)

56. To address these concerns, Darton brings this civil action seeking damages and injunctive relief for willful trademark infringement and unfair competition under the laws of the United States, 15 U.S.C. §§ 1051 *et seq.* (the “Lanham Act”).

Obsession Bows

57. On May 31, 2018, Obsession took a license to the '970 Patent.

Exhibit J (the “Obsession License”).

58. Obsession paid royalties on Licensed Products (as defined therein) pursuant to the Obsession License until September 2020.

59. Around September 2020, Obsession communicated to Darton that it was no longer interested in maintaining its compliance with the Obsession License and stopped making royalty payments.

60. Obsession’s last royalty payment pursuant to the Obsession License was tendered on or around September 2, 2020.

61. Obsession continues to make, use, sell and offer for sale Licensed Products as that term is defined in the Obsession License.

Royalties

62. Based upon Defendant Martin’s prior payments for Licensed Products, Plaintiff is informed and believes that the amount of accrued royalty

payments and interest owed by Defendant to Plaintiff under the Agreement exceeds \$140,000, exclusive of interest and late fees.

63. Based upon Defendant Obsession Bow's prior payments for Licensed Products, Plaintiff is informed and believes that the amount of accrued royalty payments and interest owed by Defendant to Plaintiff under the Agreement exceeds \$23,000, exclusive of interest and late fees.

Martin's Accused Products

64. Martin infringes the inventions claimed in the '970 patent (Ex. B), at least through its Martin Legend 730 compound bows ("Martin Accused Products"), found at <https://martinarchery.com/compound-bows/legend730/> (last visited on 9/13/2023), by using, selling, offering for sale, making, importing, or distributing compound bows utilizing the system of pulleys and cables claimed in the '970 patent resulting in a bow that operates as claimed. On information and belief, Martin uses, sells, offers for sale, makes, imports, or distributes other compound bows that use the same cam and cable system as the Legend 730 compound bow. Each of Martin's compound bows that includes the same cam and cable design as its Legend 730 compound bows also infringes the inventions claimed in the '970 Patent and are included in the definition of Martin Accused Products. Such products include, but are not limited to, the NTX 40, NTX 8, ANAXX 38, ANAXX 3D, MAXX 33, and MTX 29 models.

65. Martin sells the Martin Accused Products through its website for shipping to Michigan and throughout the United States. *See* <https://martinarchery.com/product/martin-legend-730/>, (last visited 09/13/2023).

66. The Accused Products used, sold, offered for sale, made, imported, or distributed by Martin meet each and every limitation of, at least, Claim 1 of the '970 Patent.

67. Pictured below is a representative Accused Product sold by Martin:



Martin Legend 730
compound bow

68. Upon information and belief, Martin has been directly infringing at least claim 1 of the '970 patent in Michigan, and elsewhere in the United States, by making, selling, offering to sell, and/or importing the Martin Accused Products, which integrate pulleys and cables such that they operate as recited in, at least, claim 1 of the '970 Patent.

69. The Martin Accused Products are compound archery bows that include a handle with projecting limbs:

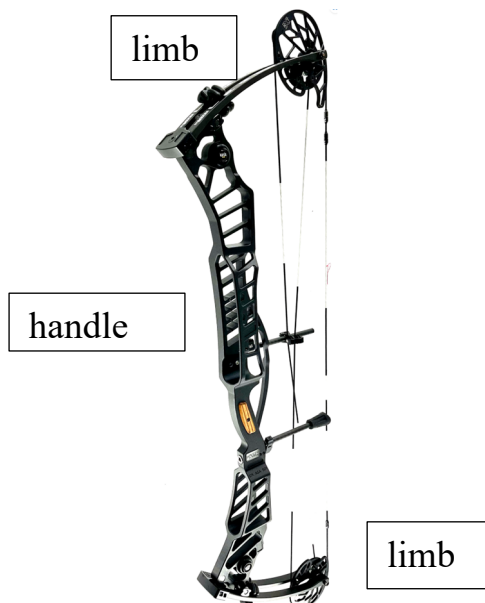

70. The Martin Accused Products have two pulleys that are mounted on each of the limbs. Both pulleys rotate around an axis:

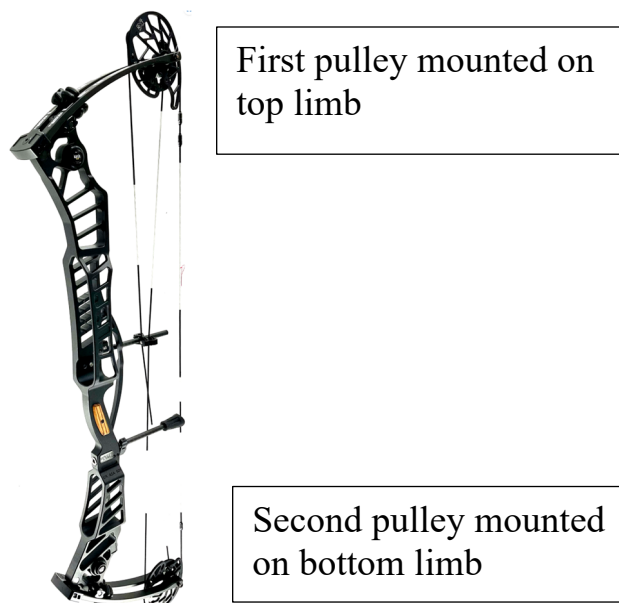

71. The Martin Accused Products have a bow cable means including a bowstring cable extending from bowstring let-out grooves on said first and second pulleys:

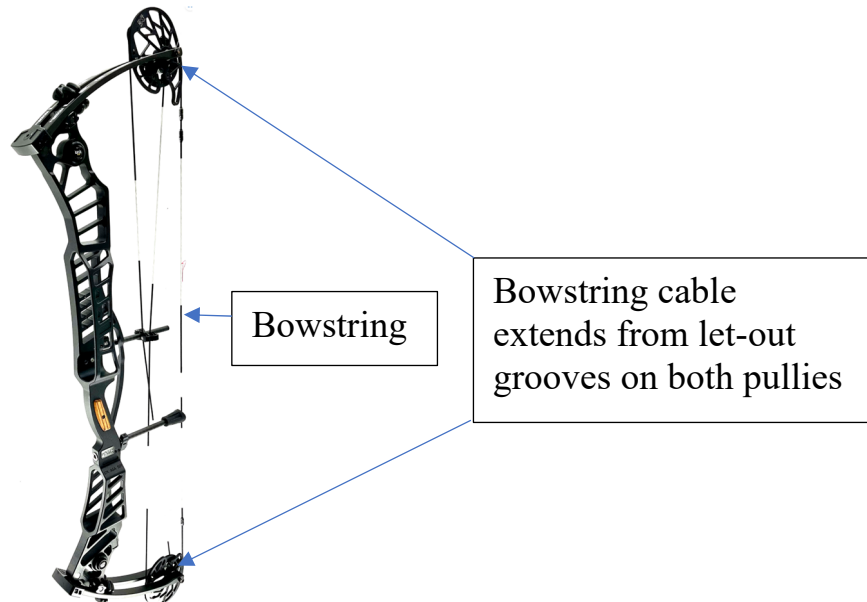

72. The Martin Accused Products have a first cable extending from a cable take-up groove on said first pulley to second cable let-out means on said second pulley:

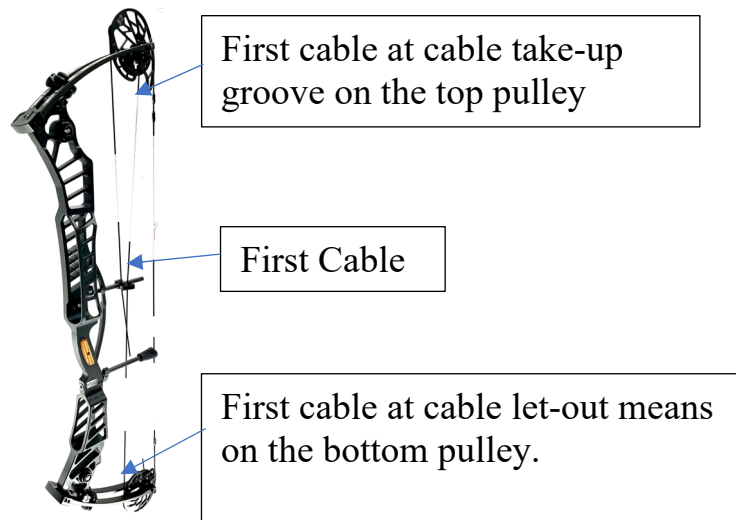

73. The Martin Accused Products have a second cable extending from a cable take-up groove in said second pulley to first cable let-out means on said first pulley:

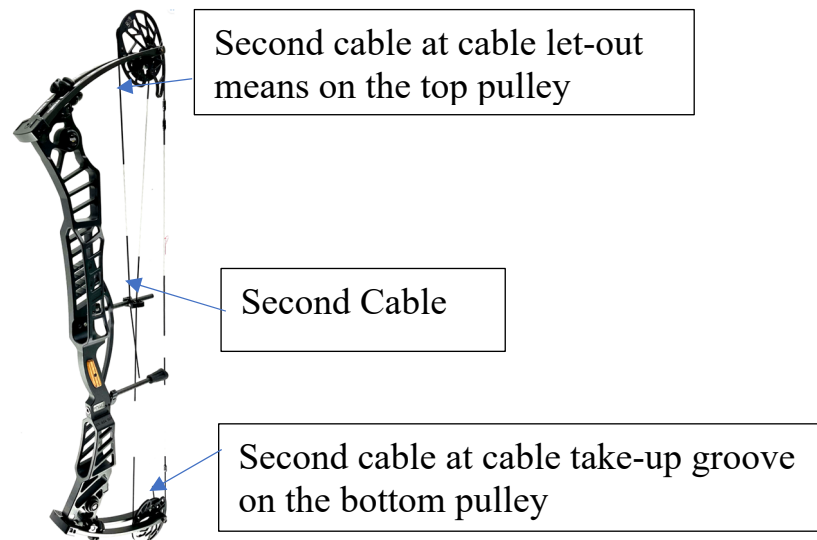

74. The Martin Accused Products operate in such a way that when a user draws the bowstring cable away from the handle, the bow lets out the bowstring cable from said let-out grooves on said first and second pulleys, rotates on said first and second pulleys around said axes, and lets out portions of said first and second cables from said first and second cable let-out means on said first and second pulleys:

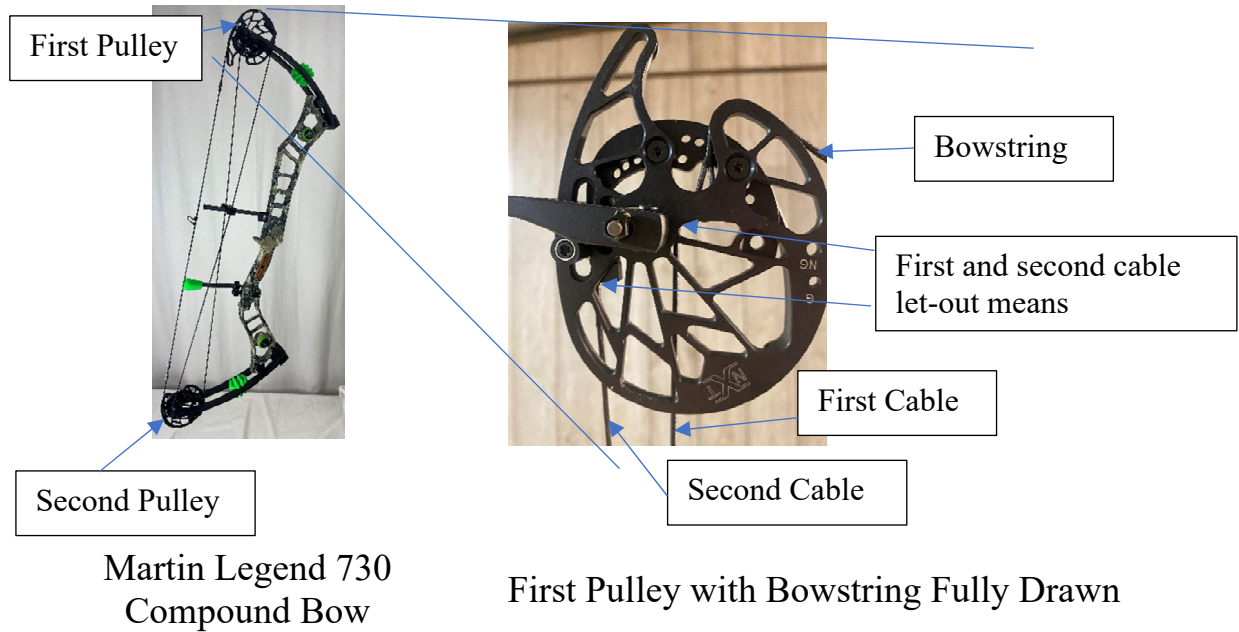

The first and second pulleys are mirror images of one other and function similarly.

75. As shown below, the bowstring let-out grooves and/or the cable take-up grooves on the cams of the Martin Accused Products are non-circular.

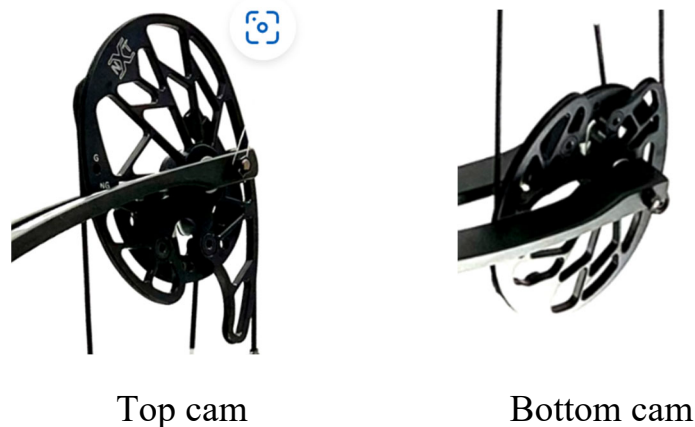

Obsession Bows' Accused Products

76. Obsession infringes the inventions claimed in the '970 patent, at least through its Nitro Ghost compound bows ("Obsession Accused Products"), found at <https://www.obsessionbowsrefueled.com/new-page-77/>, (last visited on

9/14/2023), by using, selling, offering for sale, making, importing, or distributing compound bows utilizing the system of pulleys and cables claimed in the '970 patent resulting in a bow that operates as claimed.

77. Obsession Accused Products also infringe the inventions claimed in the '658 Patent by using, selling, offering for sale, making, importing, or distributing compound bows utilizing the system of pulleys and draw stops claimed in the '658 Patent resulting in a bow that operates as claimed.

78. On information and belief, Obsession uses, sells, offers for sale, makes, imports, or distributes other compound bows that use the same cam and cable system as the Nitro Ghost compound bow. Each of Obsession's compound bows that includes the same cam and cable design as its Nitro Ghost compound bows also infringes the inventions claimed in the '970 and '658 Patents and are included in the definition of Obsession Accused Products.

79. Obsession sells the Obsession Accused Products online and ships the bows to Michigan and throughout the United States:

Redarrow Archery Supplies	
RED ARROW ARCHERY SUPPLIES, LLC 12860 Jordan Mdw N E Lowell, Michigan 49331 (616)901-1778	
Items	Price
Bow - Obsession Ghost Sight Stabilizer Quiver release Rest Arrows wrist strap bow case broadheads Peep Strings nocks mods	\$963.00
	9/22/2023
	Subtotal \$963.00
	Tax
	Total \$963.00
shipping	free
balance owed	\$- paid in full yes

Ex. A.

80. The Obsession Accused Products used, sold, offered for sale, made, imported, or distributed by Obsession meet each and every limitation of, at least, Claim 1 of the '970 Patent and Claim 1 of the '658 Patent.

81. Pictured below is a representative Obsession Accused Product sold by Obsession:



Obsession Nitro
Ghost Compound
Bow

82. Upon information and belief, Obsession has been directly infringing at least claim 1 of the '970 patent in Michigan, and elsewhere in the United States, by making, selling, offering to sell, and/or importing the Obsession Accused Products, which integrate pulleys and cables such that they operate as recited in, at least, claim 1 of the '970 Patent.

83. The Obsession Accused Products are compound archery bows that include a handle with projecting limbs:

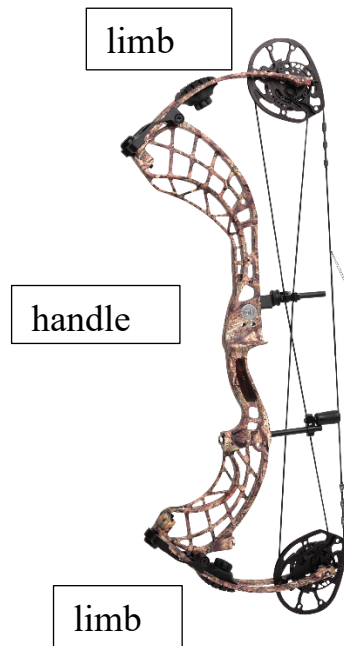

84. The Obsession Accused Products have two pulleys that are mounted on each of the limbs. Both pulleys rotate around an axis:

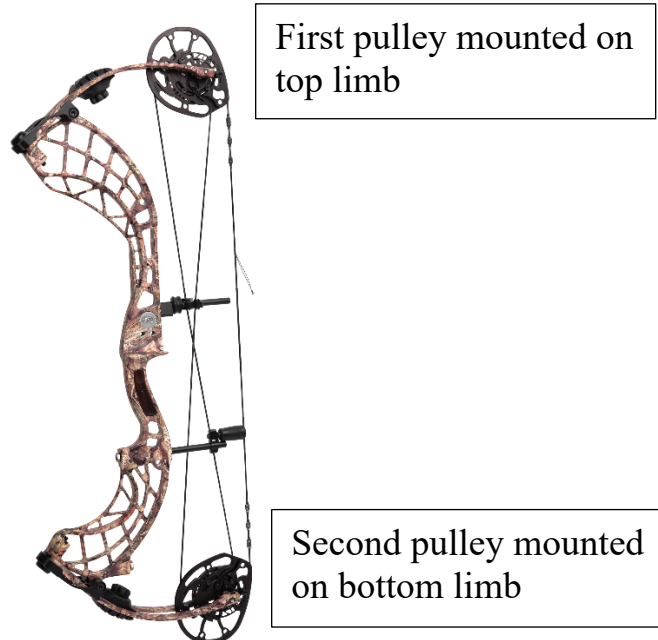

85. The Obsession Accused Products have a bow cable means including a bowstring cable extending from bowstring let-out grooves on said first and second pulleys:

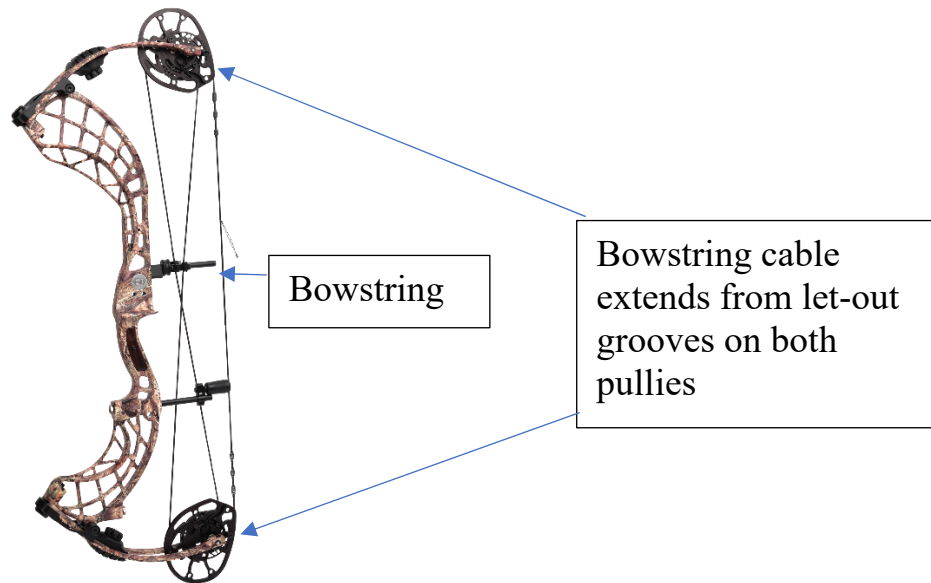

86. The Obsession Accused Products have a first cable extending from a cable take-up groove on said first pulley to second cable let-out means on said second pulley:

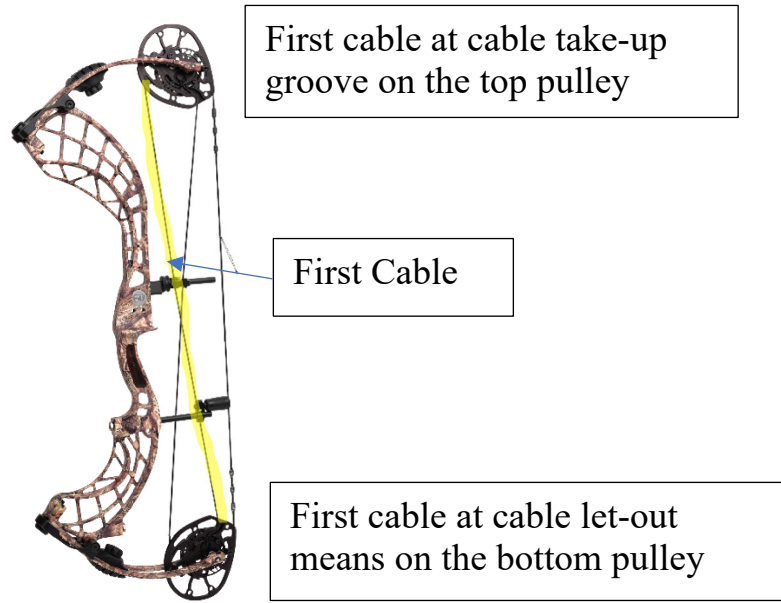

87. The Obsession Accused Products have a second cable extending from a cable take-up groove in said second pulley to first cable let-out means on said first pulley:

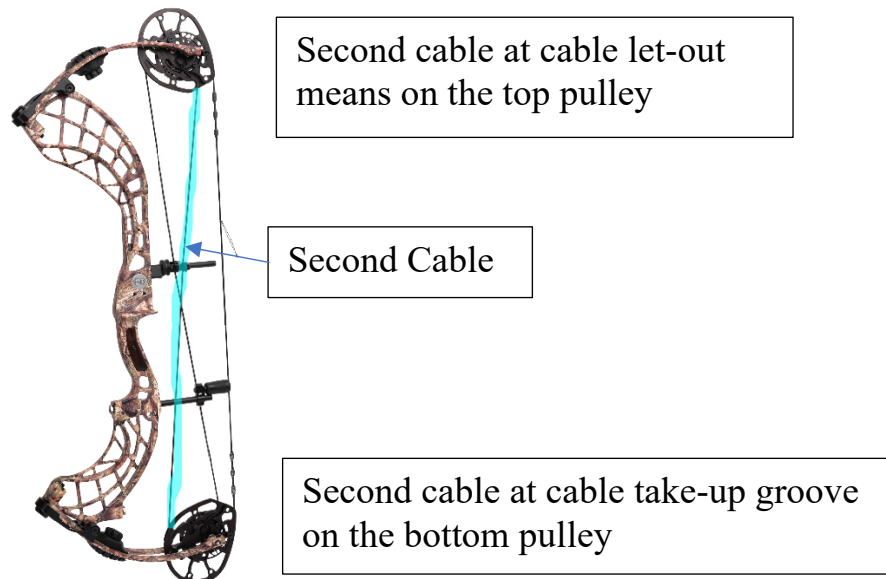

88. The Obsession Accused Products operate in such a way that when a user draws the bowstring cable away from the handle, the bow lets out the bowstring cable from said let-out grooves on said first and second pulleys, rotates on said first and second pulleys around said axes, and lets out portions of said first and second cables from said first and second cable let-out means on said first and second pulleys:

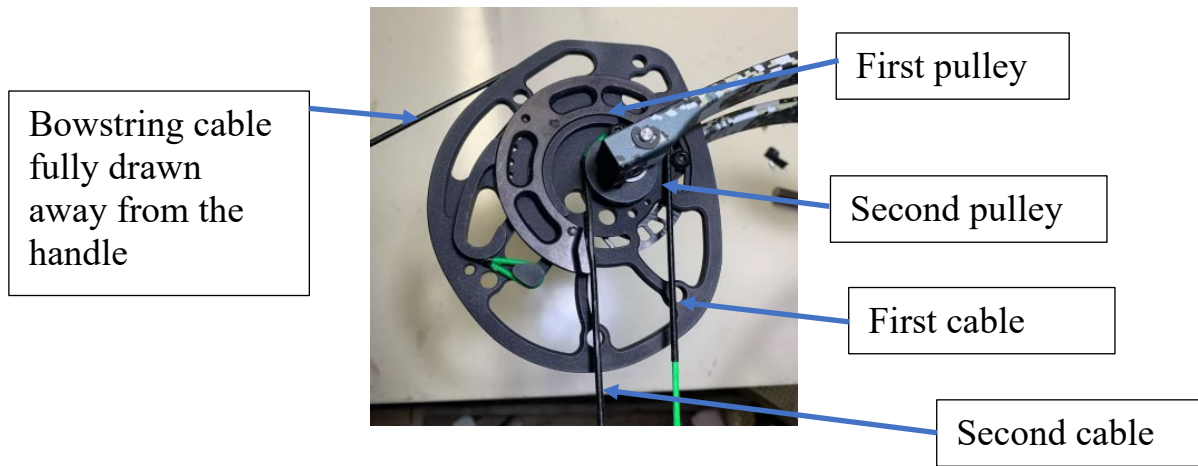

Nitro Ghost Pulley Assembly with Bowstring Fully Drawn

89. As shown below, the bowstring let-out grooves and/or the cable take-up grooves on the cams of the Obsession Accused Products are non-circular.



Top cam



Bottom cam

90. Upon information and belief, Obsession has also been directly infringing at least claim 1 of the '658 Patent (Ex. C) in Michigan, and elsewhere in the United States, by making, selling, offering to sell, and/or importing the Obsession Accused Products, which integrate pulleys and draw stops such that they operate as recited in, at least, claim 1 of the '658 Patent.

91. The Obsession Accused Products have a bow handle:

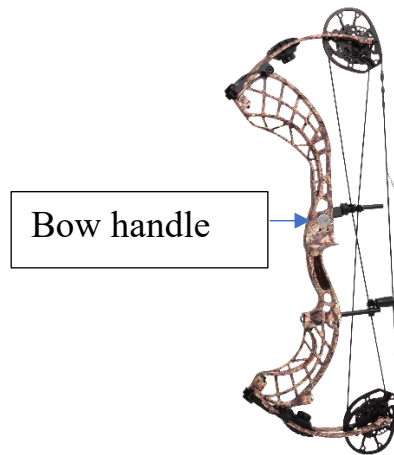

92. The Obsession Accused Products have a limb projecting from the bow handle:

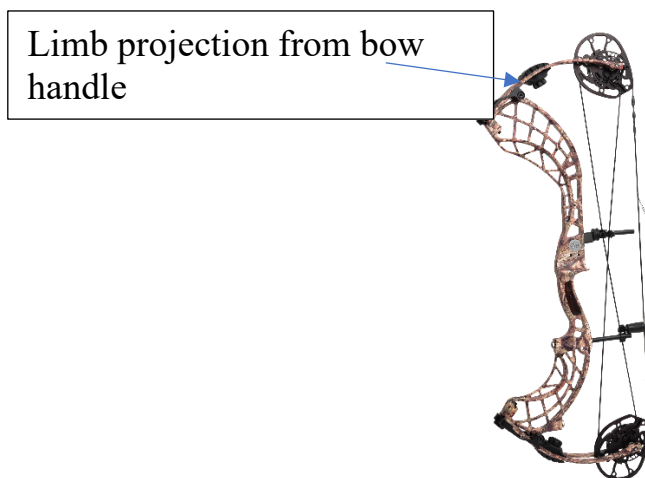

93. The Obsession Accused Products have a pulley assembly coupled to the limb for rotation around an axis:

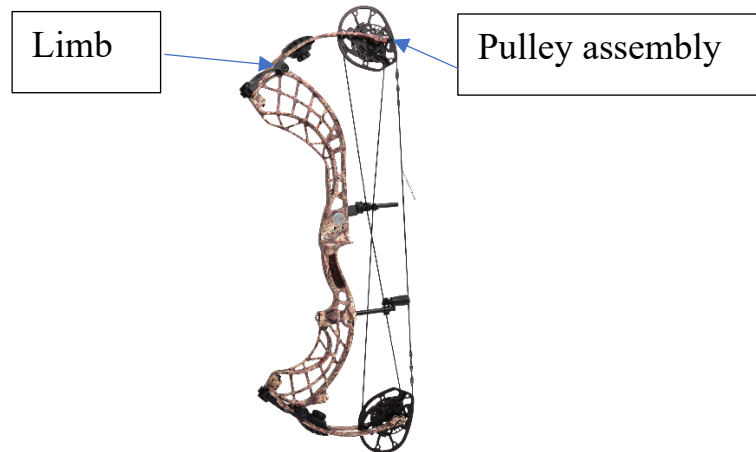

94. The Obsession Accused Products have a bowstring cam including a bowstring track in a bowstring plane:

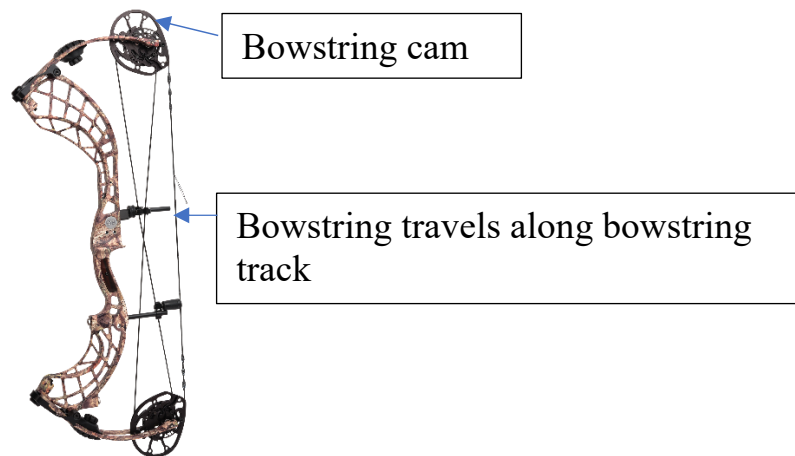

95. The Obsession Accused Products have a let-out cam carried by the bowstring cam and including a let-out track in a let-out plane spaced apart from the bowstring plane:

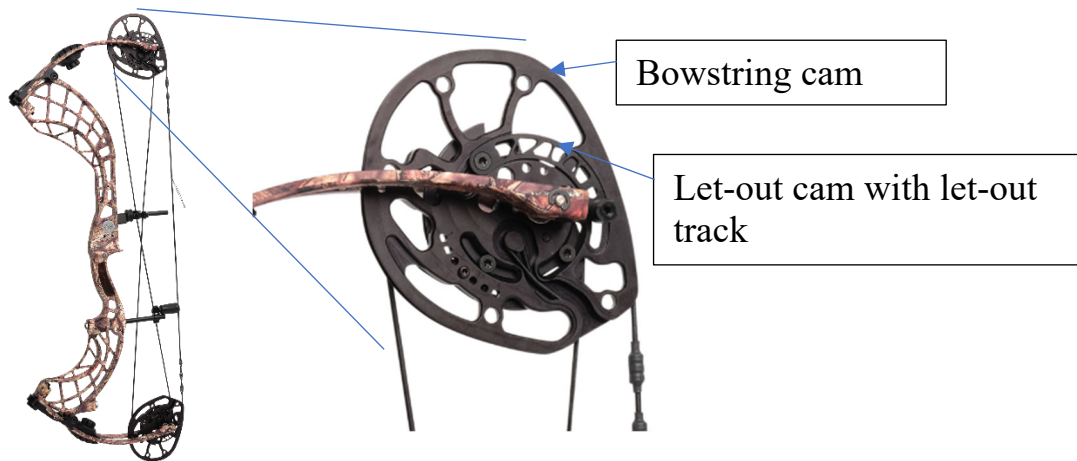

96. The Obsession Accused Products have an arcuately-shaped first take-up cam arcuately adjustably coupled to the bowstring cam and including a first take-up track in a take-up plane:

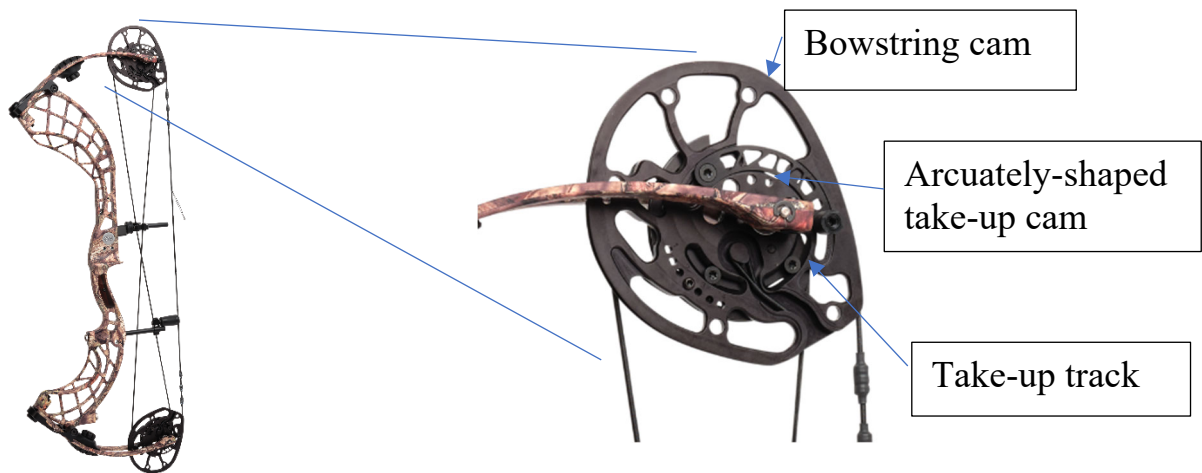

97. The Obsession Accused Products have a first draw stop at one end of the first take-up cam:

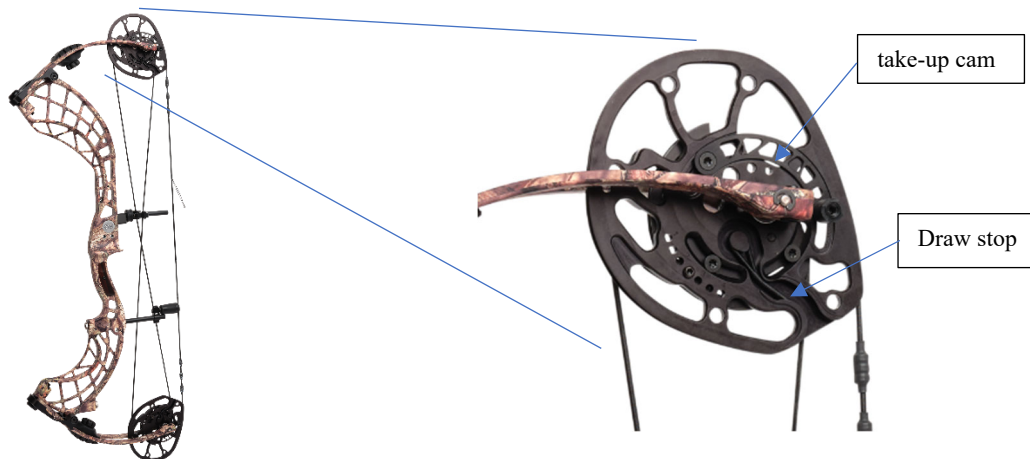

COUNT 1 – BREACH OF CONTRACT (against Martin)

98. Plaintiff incorporates paragraph 1 through 97 of this Complaint as if set forth fully herein.

99. Darton and Martin have a valid contractual agreement, based at least upon the 2018 Martin License and agreements and promises.

100. Darton has performed all or substantially all of its obligations under the 2018 Martin License.

101. Martin has materially breached the 2018 Martin License, at least by, and without limitation:

- a. Failing to tender any of the quarterly sales reports required by Section 4 thereof;
- b. Failing to make all timely payments required by Sections 2 and 3 thereof;

- c. Challenging the validity of the '970 Patent in contravention of Section 7 thereof; and
- d. Assisting or cooperating with an infringer of the '970 Patent (e.g., Obsession) in contravention of Section 7 thereof.

102. As a direct and proximate result of Defendant's breaches of the Agreement, Plaintiff has suffered damages in excess of \$140,000.

COUNT II – Breach of Contract (Against Obsession Bows)

103. Plaintiff incorporates paragraph 1 through 102 of this Complaint as if set forth fully herein.

104. Darton and Martin have a valid contractual agreement, based at least upon the Obsession License and agreements and promises.

105. Darton has performed all or substantially all of its obligations under the Obsession License.

106. Obsession has materially breached the Obsession License, at least by, and without limitation:

- b. Failing to tender all of the quarterly sales reports required by Section 4 thereof;
- c. Failing to make all timely payments required by Sections 2 and 3 thereof;

d. Challenging the validity of the '970 Patent in contravention of Section 7 thereof; and

e. Assisting or cooperating with an infringer of the '970 Patent (e.g., Martin) in contravention of Section 7 thereof.

107. As a direct and proximate result of Defendant's breaches of the Agreement, Plaintiff has suffered damages in excess of \$23,000.

COUNT III – PATENT INFRINGEMENT ('970 Patent Against Both Defendants)

108. Plaintiff incorporates paragraph 1 through 107 of this Complaint as if set forth fully herein.

109. Darton is the owner (by assignment) of the '970 Patent.

110. The claims of the '970 Patent asserted herein are valid and enforceable.

111. The United States Patent Office duly issued the '970 Patent upon finding it fully complied with Title 35 of the United States Code.

112. Defendants have no valid consent or authorization from Darton to practice the '970 Patent.

113. Martin has and currently is directly infringing one or more claims of claims of the '970 Patent in violation of 35 U.S.C. § 271(a), either literally or

under the Doctrine of Equivalents, by making, using, offering for sale, importing, distributing, and/or selling Martin Accused Products.

114. Obsession has and currently is directly infringing one or more claims of claims of the '970 Patent in violation of 35 U.S.C. § 271(a), either literally or under the Doctrine of Equivalents, by making, using, offering for sale, importing, distributing, and/or selling Obsession Accused Products.

115. Defendants willfully infringe the '970 Patent because they both had actual notice of the '970 Patent at least since the dates they were presented with licensing agreements for it and subsequently chose to violate said licensing agreements. Despite such notice, Defendants continue their respective acts of infringement without regard to the '970 Patent and will likely continue to do so unless otherwise enjoined by this Court.

COUNT IV – PATENT INFRINGEMENT ('658 Patent Against Obsession)

116. Plaintiff incorporates paragraph 1 through 115 of this Complaint as if set forth fully herein.

117. Darton is the owner (by assignment) of the '658 Patent.

118. The claims of the '658 Patent asserted herein are valid and enforceable.

119. The United States Patent Office duly issued the '658 Patent upon finding it fully complied with Title 35 of the United States Code.

120. Obsession has no valid consent or authorization from Darton to practice the '658 Patent.

121. Obsession has and currently is directly infringing one or more claims of claims of the '658 Patent in violation of 35 U.S.C. § 271(a), either literally or under the Doctrine of Equivalents, by making, using, offering for sale, importing, distributing, and/or selling Obsession Accused Products.

COUNT IV – FEDERAL TRADEMARK INFRINGEMENT (15 U.S.C. § 1114) (against Martin)

122. Plaintiff incorporates paragraph 1 through 121 of this Complaint as if set forth fully herein.

123. Darton is the owner of the DUALSYNC Mark, which bears registration number 4299445. The United States Patent and Trademark Office issued the DUALSYNC Mark on March 5, 2013 (the “Registration”).

124. Darton has been using the DUALSYNC Mark in commerce since at least January 7, 2010, in connection with “Archery Bows.”

125. The Registration is valid, subsisting, and in full force under 15 U.S.C. § 1065. It constitutes prima facie evidence of validity and of Darton’s exclusive right to use the DUALSYNC Mark pursuant to 15 U.S.C. § 1057(b).

126. The DUALSYNC Mark is a valuable asset owned by Darton.

127. Darton has expended more than \$500,000 dollars and significant effort to advertise and promote its archery bows bearing the DUALSYNC Mark. This includes its marketing spend to advertise on television, in print, and in digital media. Darton's marketing spend also includes the amount it allocates to sponsoring professional shooters in tournaments and contingencies for amateur shooters. Darton also gives a substantial number of bows to influencers to help promote its brand. As a result, the DUALSYNC Mark has acquired strong secondary meaning signifying Darton.

128. Because the DUALSYNC Mark is a strong and distinctive mark, the public recognizes it as a brand indicator of, and inextricably associated with, Darton's archery bows.

129. Martin's promotion, marketing, and advertising of archery bows as including "Dual Sync Technology" has created and is creating a likelihood of confusion, mistake, and deception among the and suction public as to the affiliation, connection, or association with Darton or the origin, sponsorship, or approval of Martin's bows by Darton in violation of 15 U.S.C. § 1114.

130. Upon information and belief, Martin adopted and used the DUALSYNC Mark with full knowledge of, and in willful disregard of Darton's rights in its service mark, and with the intent to obtain a commercial advantage that

Martin otherwise would not have, making this an exceptional case pursuant to 15 U.S.C. § 1117.

131. Darton has been, and will continue to be, damaged by Martin's infringement in an amount to be determined at trial.

132. Martin's acts also are greatly and irreparably damaging to Darton and will continue to damage Darton unless enjoined by the Court such that Darton is without an adequate remedy at law.

133. As a direct and proximate result of Martin's unauthorized use Darton has suffered damages in excess of \$150,000.

COUNT V – FEDERAL UNFAIR COMPETITION (15 U.S.C. § 1125)
(against Martin)

134. Plaintiff incorporates paragraph 1 through 133 of this Complaint as if set forth fully herein.

135. The DUALSYNC Mark is distinctive, either inherently or through acquired distinctiveness, and famous because it is widely recognized by the general consuming public of the United States as a designation of source of Darton's archery bows.

136. Martin's unauthorized use of "Dual Sync Technology," which is confusingly similar to the DUALSYNC Mark, is likely to cause confusion, deception, and mistake by creating the false and misleading impression that Martin's

archery bows are offered or distributed by Darton, or are affiliated, associated or connected with Darton, or as to the origin, sponsorship or approval of Martin's bows in violation of 15 U.S.C. § 1125.

137. Martin's unauthorized use of the infringing "Dual Sync Technology" impair the distinctiveness of the DUALSYNC Mark.

138. The similarity between Martin's use of the infringing "Dual Sync Technology" and the DUALSYNC Mark harms the reputation of the DUALSYNC Mark.

139. Martin had actual notice prior to its adoption and use of the infringing "Dual Sync Technology" in conjunction with its archery bows.

140. Martin's actions have caused, and unless enjoined by this Court, will continue to cause, serious and irreparable injury and damage to Darton, for which Darton has no adequate remedy at law.

141. Martin's aforementioned actions constitute willful and intentional infringement of Darton's rights in the DUALSYNC Mark and to trade on the goodwill associated with the DUALSYNC Mark. Thus, a finding of an exceptional case within the meaning of 15 U.S.C. § 1117 is warranted.

142. Martin's actions demonstrate an intentional, willful, and malicious intent to trade on the goodwill associated with the DUALSYNC Mark thus entitling Darton to injunctive relief and to recover Martin's profits, actual

damages, enhanced profits and damages, costs, and attorneys' fees pursuant to 15 U.S.C. §§ 1114, 1116, and 1117.

WHEREFORE, Plaintiff Darton Archery, LLC request entry of a preliminary and permanent injunction, and that judgment be entered against Defendants, each in an amount in excess of \$500,000 plus pre-judgment interest, costs, and any other or further relief which this Court deems just and proper.

JURY DEMAND

Plaintiff demands a trial by jury on all issues triable to a jury.

DARTON ARCHERY, LLC

By: Michelle W. Skinner/

Jamal M. Edwards P.C.
jedwards@em3law.com
EDWARDS MAXSON MAGO &
MACUALAY LLP
1530 Groton Rd.
Bloomfield Hills, MI 48302
Telephone : (312) 803-0378

Michelle W. Skinner
miskinner@em3law.com
Michael B. Cohen
mcohen@em3law.com
EDWARDS MAXSON MAGO &
MACUALAY LLP
444 W. Wacker Drive, Suite 4500
Chicago, IL 60601
Telephone: (312) 803-0378

Its Attorneys

VERIFICATION

I, Randy Kitts, declare as follows:

1. I am the Chief Executive Officer of Plaintiff Darton Archery, LLC.
2. I have read the above Verified Complaint against Martin Outdoor, LLC, d/b/a "Martin Archery," and Jeffersonville Georgia, LLC, d/b/a "Obsession Bows."
3. The facts stated therein are true and correct to the best of my personal knowledge, information, and belief.
4. I verify under penalty of perjury that that the foregoing is true and correct.

Executed on October __18__, 2023.



Randy Kitts