

**UNITED STATES DISTRICT COURT
SOUTHERN DISTRICT OF FLORIDA**

DUVALL ESPRESSO IP ENFORCEMENT, LLC,
a Florida Limited Liability Company,

CASE NO.: 9:23cv81375

Plaintiffs,

v.

METICULOUS HOME, INC., a Delaware Corporation,
and JUAN CARLOS LOPEZ PENDAS, an individual,

Defendants.

COMPLAINT

Plaintiff, DUVALL ESPRESSO IP ENFORCEMENT, LLC (hereinafter “Duvall LLC” or “Plaintiff”), a Florida Limited Liability Company, by and through the undersigned counsel, hereby files this Complaint against Defendants, METICULOUS HOME, INC., a Delaware Corporation (hereinafter “Meticulous Inc.”), and JUAN CARLOS LOPEZ PENDAS, an individual (“Defendant Lopez”) and, in so doing, state as follows:

JURISDICTION, VENUE AND THE PARTIES

1. This is an action which is, *in part*, brought pursuant to the Patent Laws of the United States, 35 U.S.C. §§ 271, *et. seq.*

2. This Court has original jurisdiction pursuant to Title 28, United States Code, Section 1331, as this case involves a federal question arising under the Constitution, laws, or treaties of the United States.

3. Duvall LLC is a Florida Limited Liability Company with its principal address located in Palm Beach County, Florida and regularly transacts business within this judicial district.

4. Duvall LLC is owned and operated by Duvall Espresso, Inc., a Delaware corporation operating as foreign entity in Georgia, where Duvall Espresso, Inc. has its principal place of business.

5. At all times material hereto, Meticulous Inc. was and is a Delaware corporation that is believed to be operating in California, but was and is engaged in the conduct of interstate commerce within the United States, which includes this judicial district, and is otherwise *sui juris*.

6. At all times material hereto, Defendant Lopez was and is believed to be a resident of California and is otherwise *sui juris*.

7. Since at least February of 2023, Meticulous Inc. has been engaged in U.S. interstate commerce, i.e., marketing and selling electric coffee and espresso making machines, wherein, upon information and belief, all of said electric coffee and espresso making machines (“Accused Products”) infringe on the patents of Duvall LLC referenced herein. See https://tsdr.uspto.gov/#caseNumber=97976390&caseType=SERIAL_NO&searchType=statusSearch.

8. At all times material hereto, Meticulous Inc. was and is engaged in the conduct of interstate commerce within the United States, including directly or indirectly regularly conducting business in this judicial district, e.g., at least through the following interactive websites: <https://www.kickstarter.com/projects/meticulous/meticulous-espresso> (“Kickstarter Website”) (stating Meticulous Inc. ships “[a]nywhere in the world”), <https://meticuloushome.com/>, https://uncrate.com/meticulous-espresso-machine/?utm_campaign=gs-2020-01-28&utm_source=google&utm_medium=smart_campaign&gad=1&gclid=Cj0KCQjwjt-

[oBhDKARIsABVRB0yngJS18tr2tuOJTRr74xCaxzf6V8MXavlfzonyCmKWEKgQ0cs0Zh4aAmkEALw_wcB,](https://www.indiegogo.com/projects/meticulous-espresso?utm_medium=cpc&gclid=Cj0KCQjwjt-oBhDKARIsABVRB0w_6bxXLnX-zW8PjSLsbdq7zvT_newyeaRo3ltPA1zBKuQOhYjqsAv7vEALw_wcB&utm_source=gog#/) and https://www.indiegogo.com/projects/meticulous-espresso?utm_medium=cpc&gclid=Cj0KCQjwjt-oBhDKARIsABVRB0w_6bxXLnX-zW8PjSLsbdq7zvT_newyeaRo3ltPA1zBKuQOhYjqsAv7vEALw_wcB&utm_source=gog# (“Indiegogo Website”).

9. At all times material hereto, Defendant Lopez was the owner, controlling individual, and/or operator of Meticulous Inc. and its domain,

10. Defendant Lopez has also directly or indirectly filed corporate filings for Meticulous Inc. as an officer thereof.

11. Defendant Lopez is believed to be control the content of the Indiegogo Website, wherein the Indiegogo Website states that Meticulous Inc. has raised “\$525,320 USD” by “478 backers” and Defendant Lopez is believed to be control the content of the Kickstarter Website, wherein the Kickstarter Website states that Meticulous Inc. has raised “\$4,960,578 USD” by “3,774 backers”, wherein each of said websites market the Accused Products to U.S. consumers, including those within this judicial district.

12. Upon information and belief, at least a portion of the funds received by Defendants through the above-referenced website and for the Accused Products were from consumers/users within the state of Florida, including within this judicial district.

13. Venue is proper in this judicial district under 28 U.S.C. § 1391(b)(2) and (b)(3) because a substantial part of the events or omissions giving rise to the claim occurred in this judicial district and because Defendants are subject to the Court’s personal jurisdiction.

14. All conditions precedent have been met, waived, or satisfied to bring this lawsuit.

GENERAL ALLEGATIONS

15. Gideon Duvall (“Mr. Duvall”) is the principal officer and owner of Duvall Espresso, Inc., the owner of Duvall LLC.

16. Mr. Duvall is and has been involved in the development and production of espresso-related and coffee-related products since as early as 2008.

17. Mr. Duvall has numerous U.S. and foreign patents issued directed toward espresso-related and coffee-related products. See, e.g., <https://www.duvallespresso.com/pageip>.

18. Duvall Espresso, Inc. is in the business of commercially developing, marketing, and selling espresso-related and coffee-related products. See, e.g., <https://www.duvallespresso.com/>.

19. Duvall Espresso, Inc. has invested significant resources, e.g., time and money, in commercially developing, marketing, and selling espresso-related and coffee-related products.

20. Duvall Espresso, Inc. has also invested significant resources, e.g., time and money, in protecting innovations associated with its espresso-related and coffee-related products.

21. Duvall Espresso, Inc. and Duvall LLC are direct competitors of Meticulous Inc.

22. As relevant herein, Mr. Duvall was the original recipient and owner of the following U.S. Patents (collectively referred to as the “Asserted Duvall Patents”):

- i. U.S. Patent No. 10,349,774 (“the ‘774 Patent”), issued on July 16, 2019, for a “Device and System for Creating Infused Beverages”. See **Exhibit A** (a true and correct copy of the ‘774 Patent).
- ii. U.S. Patent No. 10,258,187 (“the ‘187 Patent”), issued on April 16, 2019, for a “Device and System for Brewing Infused Beverages”. See **Exhibit B** (a true and correct copy of the ‘187 Patent).

iii. U.S. Patent No. 9,867,491 (“the ‘491 Patent”), issued on January 16, 2018, for a “Device and System for Brewing Infused Beverages”. See **Exhibit C** (a true and correct copy of the ‘491 Patent).

23. Each of the Asserted Duvall Patents were assigned to Duvall LLC before the filing of this lawsuit.

24. The invention described in independent claims 1, 19, and 20 of the ‘774 Patent is specifically directed toward a device and system for creating infused beverages that includes a pump configured to pump solvent, e.g., water, through a pump body that also includes a heating element outside of the flow of the solvent and configured to heat the solvent through conduction, wherein an electronic controller is configured to heat and pump the solvent. **Exhibit A**, at 18-20.

25. Claim 1 of the ‘774 Patent, by way of example, is recited below:

1. A system for creating infused beverages comprising:

a solvent flow management system having a pump housed in a pump body and operably coupled to a pump drive system operably configured to drive the pump to induce a flow of a solvent, housed by the pump, through a solute housed in a brewing chamber to generate an infused solution, the brewing chamber and the pump fluidly coupled through a solvent-flow conduit;

a solvent temperature management system having a heating element disposed within the pump body and outside of fluid contact with the solvent, the heating element operably configured to activate and thermally couple with the solvent housed by the pump through conduction within a material of the pump body; and

an electronic control system communicatively coupled to the solvent flow management system and the solvent temperature management system, the electronic control system operably configured to activate the pump drive system and to activate the heating element.

26. The invention described in independent claim 10 of the ‘774 Patent is specifically directed toward a device and system for creating infused beverages that includes a pump body with a piston therein that is configured to move within the pump body in a single translation to

induce a flow of the water and of a volume equal to displacement volume of the piston, wherein said flow and volume is transported to the brewing chamber for infusion with ground beans (i.e., a solute) and out through an outlet that is controlled by a controller. **Exhibit A**, at 19.

27. Claim 10 of the '774 Patent, by way of example, is recited below:

10. A device for creating infused beverages comprising:

a solvent flow management system having:

a pump body with a pump bore defining a pump interior volume;

a piston disposed within the pump interior volume and in a fluidically sealed configuration with the pump bore;

a pump drive system operably configured to translate the piston from a first position to a second position along a piston translation path, wherein the second position of the piston results in a reduced volumetric capacity of the pump interior volume than a volumetric capacity of the pump interior volume when the piston is in the first position wherein the volumetric capacity differential is equal to the desired dispensed fluid volume;

a pump-valve conduit downstream of the pump interior volume and in fluid communication with a brewing chamber for housing a solute;

an electronic control system communicatively coupled to the solvent flow management system and operably configured to initiate a brewing cycle generating an infused solution, by flow of the solvent through the solute in the brewing chamber, through a single translation of the piston along the piston translation path into the second position; and

an outlet downstream of the brewing chamber for discharging the infused solution.

28. In late April of 2023, Defendant Lopez and Mr. Duvall spoke at the Specialty Coffee Expo and was told that the Accused Products infringed multiple patents of Mr. Duvall, wherein Defendant Lopez requested Mr. Duvall to send him a formal letter outlining the infringement.

29. On June 22, 2023, a notice of patent infringement letter was sent to and received by Defendant Lopez, wherein it was described in said letter how and why the Accused Products

infringed the '774 Patent and other patents of Mr. Duvall. See **Exhibit D** (a true and correct copy of said letter).

30. More specifically, below are true and accurate images of the Accused Products that are annotated for the purposes of illustrating infringement of the '774 Patent and the Asserted Duvall Patents.

Solvent flow and solvent temperature management systems connected to electronic control system for control



Pump/piston
Pump body
Heating element within pump body, outside of fluid contact, and heating solvent through conduction

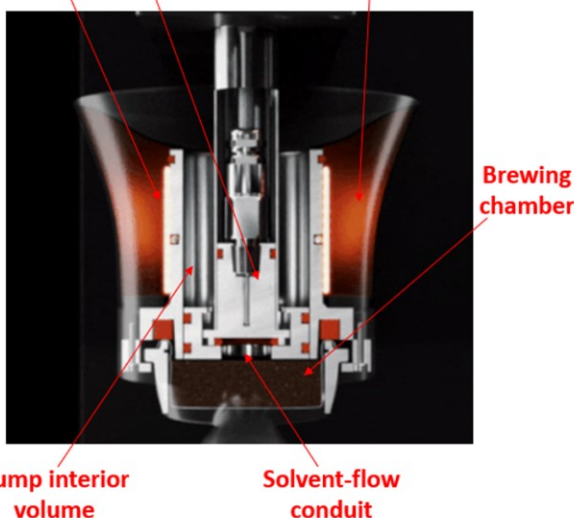

Pump/Piston in first/raised position allowing introduction of solvent
Pump drive system

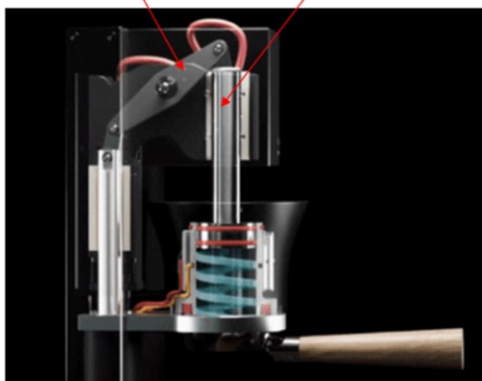

Pump/Piston in second/lowered position that reduces volumetric capacity of the pump interior volume in a single translation of piston that is equal to the desired dispensed fluid volume

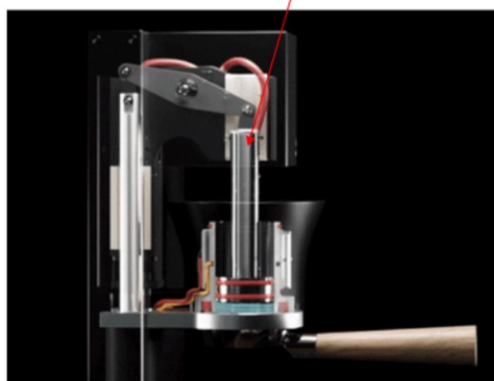

31. The invention described in independent claim 1 of the '187 Patent is specifically directed toward an infused beverage brewing assembly that includes a solvent flow management system configured to change or maintain a flow of solvent (e.g., water) through the brewing chamber where the ground beans (i.e., solute) are housed independent of a back pressure within a brewing chamber of the infused beverage brewing assembly and without a feedback mechanism (like a sensor) for monitoring the flow of the solvent, wherein the Accused Products are configured in the same infringing way using its piston configuration, *supra*. See also **Exhibit B**, at 17.

32. The invention described in independent claims 8 and 16 of the '187 Patent is specifically directed toward an infused beverage brewing assembly and method that includes a solvent flow management system including a 100% volumetric efficiency motor-driven pump configured to change or maintain a flow of solvent (e.g., water) through the brewing chamber where the ground beans (i.e., a solute) is housed, wherein the Accused Products are also configured in the same infringing way using its piston configuration, *supra*. See also **Exhibit B**, at 17-18.

33. The invention described in independent claims 1, 7, and 17 of the '491 Patent is specifically directed, similar to the '187 Patent, toward an infused beverage brewing assembly and method that includes a solvent flow management system configured to change or maintain a flow of solvent (e.g., water) through the brewing chamber where the ground beans (i.e., solute) are housed independent of a back pressure within a brewing chamber of the infused beverage brewing assembly and without a feedback mechanism (like a sensor) for monitoring the flow of the solvent, wherein the Accused Products are configured in the same infringing way using its piston configuration, *supra*. See also **Exhibit C**, at 17-19.

34. Despite having actual knowledge of the Asserted Duvall Patents and infringement of the same, Defendants have continued to sell, manufacture, use, import, and market the Accused Products in an infringing manner.

35. As a direct result of the Defendants' actions, Duvall LLC has retained the services of counsel, and are obligated to pay their counsel all attorneys' fees and costs associated with the investigation, preparation, and prosecution of the instant lawsuit.

36. Duvall LLC has complied with and met all conditions precedent and concurrent to the bringing of this action, or all conditions precedent and concurrent to the bringing of this action have been waived or excused by the Defendants' conduct.

COUNT I - WILLFUL DIRECT INFRINGEMENT OF U.S. PATENT NO. 10,349,774
(AGAINST ALL DEFENDANTS)

37. Duvall LLC realleges and revers paragraphs one (1) through thirty-six (36) as if fully set forth herein.

38. This is an action for direct patent infringement pursuant to Title 35, United States Code, Section 271(a), of the United States Patent Act.

39. Defendants have directly infringed, and continues to infringe, at least claims 1, 10, 19, and 20 of the '456 Patent, by, *at least*, selling, manufacturing, using, importing, and marketing the Accused Products.

40. Specifically, Defendants have infringed, literally and under the doctrine of equivalents, claims 1, 10, 19, and 20 of the '774 Patent by selling, manufacturing, using, importing, and marketing the Accused Products that include all elements recited within claims 1, 10, 19, and 20 of the '774 Patent and/or that include structure that has the same function or purposes of the structure recited in claims 1, 10, 19, and 20 of the '774 Patent.

41. As set forth above, Defendants clearly had knowledge of the ‘774 Patent, what products infringed the ‘774 Patent, why the Accused Products infringed the ‘774 Patent, and the consequences of infringement; yet, Defendants continued to sell, manufacture, use, import, and market the Accused Products.

42. All such infringing conduct for the ‘774 Patent of Defendants has occurred and was committed in a willful manner.

43. Defendants have caused, and continue to cause, irreparable harm to Duvall LLC and its owner for which there is no adequate remedy at law.

44. Defendants conduct in this instance is exceptional, and, as such, Duvall LLC should be entitled to recover its attorneys’ fees in this action pursuant to 35 U.S.C. § 285 which provides that the “court in exceptional cases may award reasonable attorney fees to the prevailing party.”

COUNT II - WILLFUL DIRECT INFRINGEMENT OF U.S. PATENT NO. 10,258,187
(AGAINST ALL DEFENDANTS)

45. Duvall LLC realleges and revers paragraphs one (1) through thirty-six (36) as if fully set forth herein.

46. This is an action for direct patent infringement pursuant to Title 35, United States Code, Section 271(a), of the United States Patent Act.

47. Defendants have directly infringed, and continues to infringe, at least claims 1, 8, and 16 of the ‘187 Patent, by, *at least*, selling, manufacturing, using, importing, and marketing the Accused Products.

48. Specifically, Defendants have infringed, literally and under the doctrine of equivalents, claims 1, 8, and 16 of the ‘187 Patent by selling, manufacturing, using, importing, and marketing the Accused Products that include all elements recited within claims 1 and 8 of

the '187 Patent and/or that include structure that has the same function or purposes of the structure recited in claims 1, 8, and 16 of the '187 Patent.

49. As set forth above, Defendants clearly had knowledge of the '187 Patent, what products infringed the '187 Patent, why the Accused Products infringed the '187 Patent, and the consequences of infringement; yet, Defendants continued to sell, manufacture, use, import, and market the Accused Products.

50. All such infringing conduct for the '187 Patent of Defendants has occurred and was committed in a willful manner.

51. Defendants have caused, and continue to cause, irreparable harm to Duvall LLC and its owner for which there is no adequate remedy at law.

52. Defendants conduct in this instance is exceptional, and, as such, Duvall LLC should be entitled to recover its attorneys' fees in this action pursuant to 35 U.S.C. § 285 which provides that the "court in exceptional cases may award reasonable attorney fees to the prevailing party."

COUNT III - WILLFUL DIRECT INFRINGEMENT OF U.S. PATENT NO. 9,867,491
(AGAINST ALL DEFENDANTS)

53. Duvall LLC realleges and revers paragraphs one (1) through thirty-six (36) as if fully set forth herein.

54. This is an action for direct patent infringement pursuant to Title 35, United States Code, Section 271(a), of the United States Patent Act.

55. Defendants have directly infringed, and continues to infringe, at least claims 1, 7, and 17 of the '491 Patent, by, *at least*, selling, manufacturing, using, importing, and marketing the Accused Products.

56. Specifically, Defendants have infringed, literally and under the doctrine of equivalents, claims 1, 7, and 17 of the '491 Patent by selling, manufacturing, using, importing, and marketing the Accused Products that include all elements recited within claims 1, 7, and 17 of the '491 Patent and/or that include structure that has the same function or purposes of the structure recited in claims 1, 7, and 17 of the '491 Patent.

57. As set forth above, Defendants clearly had knowledge of the '491 Patent, what products infringed the '491 Patent, why the Accused Products infringed the '491 Patent, and the consequences of infringement; yet, Defendants continued to sell, manufacture, use, import, and market the Accused Products.

58. All such infringing conduct for the '491 Patent of Defendants has occurred and was committed in a willful manner.

59. Defendants have caused, and continue to cause, irreparable harm to Duvall LLC and its owner for which there is no adequate remedy at law.

60. Defendants conduct in this instance is exceptional, and, as such, Duvall LLC should be entitled to recover its attorneys' fees in this action pursuant to 35 U.S.C. § 285 which provides that the "court in exceptional cases may award reasonable attorney fees to the prevailing party."

WHEREFORE, Duvall LLC, by and through the undersigned, hereby respectfully demands judgment against all Defendants, wherein said judgment should include provisions:

- a) temporarily and permanently enjoining Defendants and all of those acting in concert with them, including, but not limited to, their agents, affiliates, subsidiaries, officers, directors, attorneys and employees from using, making, selling, marketing, importing, or offering to sell the Accused Products, and all colorable imitations thereof;

- b) issuing a declaration or order finding the Accused Products are infringing at least claims 1, 10, 19, and 20 of the '774 Patent, claims 1, 8, and 16 of the '187 Patent, and claims 1, 7, and 17 of the '491 Patent;
- c) compensating Duvall LLC for the full amount of damages sustained, including, but not limited to, any and all damage remedies available pursuant to the Patent Laws of the United States, 35 U.S.C. §§ 271, *et. seq.*, which include, but are not limited to a reasonable royalty award;
- d) declaring this case exceptional and trebling all damages awarded to Duvall LLC;
- e) imposition of all pre and post judgment interest at the maximum allowable rate on the full compensatory and trebled amount awarded to Duvall LLC;
- f) awarding remuneration of all attorneys' fees, costs and expenses for Duvall LLC having to investigate, prepare and prosecute this action; and
- g) for such further and additional relief this Court deems just and proper under the circumstances.

DEMAND FOR JURY TRIAL

Duvall LLC hereby demands trial by jury of all issues so triable as a matter of law.

Dated: October 5, 2023

Respectfully submitted,

By: /s/ Mark C. Johnson
Mark C. Johnson, Esq.
MJ@JohnsonDalal.com
Service@JohnsonDalal.com

Fla. Bar. # 84365

JOHNSON | DALAL
111 N. Pine Island Road
Suite 105
Plantation, FL 33324

Attorneys for Plaintiff