

FILED
U.S. DISTRICT COURT
EASTERN DISTRICT ARKANSAS

IN THE UNITED STATES DISTRICT COURT
FOR THE EASTERN DISTRICT OF ARKANSAS
CENTRAL DIVISION

JAN 19 2024

TAMMY H. DOWNS, CLERK

By:  DEP CLERK

SMITH'S CONSUMER PRODUCTS, :
INC., a Delaware Corporation, :

Plaintiff, :

v. : Civil Action No. 4:24-cv-45-KGB

LOWE'S COMPANIES, INC. :
A North Carolina Corporation, :

and :

LOWE'S HOME CENTERS, LLC : This case assigned to District Judge Baker
A North Carolina Limited Liability Co., : and to Magistrate Judge Volpe

Defendants. :

COMPLAINT FOR PATENT INFRINGEMENT

Smith's Consumer Products, Inc. ("Plaintiff"), by its undersigned attorneys, hereby files its Complaint for Patent Infringement against Lowe's Companies, Inc. and Lowe's Home Centers, LLC ("Defendants") and alleges as follows:

NATURE OF THE ACTION

1. This is an action for infringement of U.S. Patent No. 8,944,894 B2 ("the '894 patent") arising under the patent laws of the United States, Title 35, United States Code, Sections 100 et seq. The '894 patent discloses and claims an adjustable sharpener for the blade of a knife.

THE PARTIES

2. Smith's Consumer Products, Inc. is a Delaware corporation with a principal place of business at 747 Mid-America Blvd., Hot Springs, Arkansas 71913.

3. Upon information and belief, Defendants are a North Carolina Corporation and a North Carolina Limited Liability Company, respectively, each with a principal place of business at 1000 Lowe's Blvd., Mooresville, NC 28117-8520. Upon information and belief, Lowe's Home Centers, LLC is a wholly owned subsidiary of Lowe's Companies, Inc. Defendants are part of a retail company that specializes in home improvement.

JURISDICTION AND VENUE

4. This Court has subject matter jurisdiction over this Complaint pursuant to 28 U.S.C. §§ 1331 (federal question) and 1338(a) (patent infringement).

5. Upon information and belief, this Court has personal jurisdiction over Defendants because Defendants make, import, distribute, use, sell, and/or offer to sell infringing product (defined hereinafter) with the knowledge and/or intent that the infringing devices will be offered for sale, sold, or used throughout the United States, including this state. Defendants have purposefully established sufficient minimum contacts with this forum to comport with fair play and substantial justice. Defendants operate twenty-one (21) stores in the State of Arkansas, and have sold infringing product in its stores located within this District.

6. Venue is proper in this district pursuant to 28 U.S.C. § 1400(b). On information and belief, Defendants have committed acts of infringement of the '894 patent in this District by offering for sale infringing product and have a regular and established place of business in this District at least at West Little Rock Lowe's, AR Store #3331; 1100 South Bowman Road, Little Rock, AR 72211.

ASSERTED PATENT

7. On February 3, 2015, the U.S. Patent and Trademark Office duly and legally issued the '894 patent, entitled "ADJUSTABLE ABRASIVE SHARPENER". The '894 patent is

valid and enforceable. A true and correct copy of the '894 patent is attached as Exhibit A. The claims of the '894 patent cover a sharpener with a pair of abrasive elements, where at least one of the abrasive elements is mounted for pivotal movement. The claims of the '894 patent carry a presumption of validity under 35 U.S.C. § 282(a).

8. Plaintiff is the owner of the entire right, title and interest in the '894 patent by assignment, and possesses the right to sue for and obtain equitable relief and damages for infringement of the patent-in-suit.

9. Plaintiff sells adjustable sharpeners. For example, Plaintiff sells an adjustable sharpener under the name "Adjustable Angle Pull-Thru Knife Sharpener" (SKU: 50264) for \$29.99 on its website. Plaintiff also sells an adjustable sharpener under the name "Smith's 50146 Adjustable Angle Knife Sharpener - Stainless - Adjustable Sharpening Angles - Repair, Restore & Polish Blades - 2-Stage Handheld Manual Sharpener - Kitchen, Straight & Serrated Knives" for \$36.52 on Amazon.com. These adjustable sharpeners are covered by the claims of the '894 patent.

FACTS

10. Plaintiff repeats and incorporates by reference the allegations of the preceding paragraphs as if fully set forth herein.

11. Since at least as early as 1886 when the company was founded, Plaintiff has produced a wide variety of consumer goods, including sharpening tools and instruments.

12. Plaintiff has continuously sold knife and tool sharpeners since at least as early as 1960.

13. Defendants are one of the largest home improvement retailers in the world, and operate retail stores throughout the United States, including in Arkansas.

14. Defendants have directly infringed and continue to directly infringe the '894 patent by making, using, selling, offering for sale, and/or importing into the United States an adjustable sharpener. For example, Defendants sell the Kobalt Adjustable Sharpener with Suction Cup Base (Item #5300875; Model #19744) (hereinafter "Accused Product"; see Figs. A and B below), embodying the invention defined by one or more claims of the '894 patent, without authority or license from Plaintiff. The Accused Product is sold in Defendants' stores in this District.

15. More particularly, upon information and belief, Defendants have infringed and continue to infringe at least claims 14-16 of the '894 patent because the Accused Product includes every element of claims 14-16.

16. Claim 14 of the '894 patent recites as follows:

An adjustable sharpener comprising:
a frame having an open sharpening slot,
a pair of abrasive elements being mounted in said slot to form a generally V- shaped sharpening angle in said slot, at least one of said abrasive elements being mounted for pivotal movement,
a rotatable rod being mounted on said frame, and
a connecting rack assembly being mounted for axial movement on said frame and being connected between said rod and said at least one of said abrasive elements whereby rotation of said rod effects axial movement of said rack assembly to cause pivotal movement of said at least one of said abrasive elements with respect to the other of said abrasive elements to adjust said sharpening angle form by said pair of abrasive elements.

17. The Accused Product is an adjustable sharpener that is configured to receive a portion of a blade of a knife in an open sharpening slot in upper end of a frame, as shown in Fig. A below. Fig. A below shows the Accused Product when it is removed from the packaging and ready for use. Fig. B below shows internal components of the Accused Product that are only

visible when the frame is removed. A pair of abrasive elements are mounted in the slot and form a V-shaped sharpening angle in the slot. By rotation of an adjustable actuator that extends slightly outwardly beyond the frame, the pair of abrasive elements pivot with respect to each other. These above features correspond to the first two elements recited in the body of claim 14.

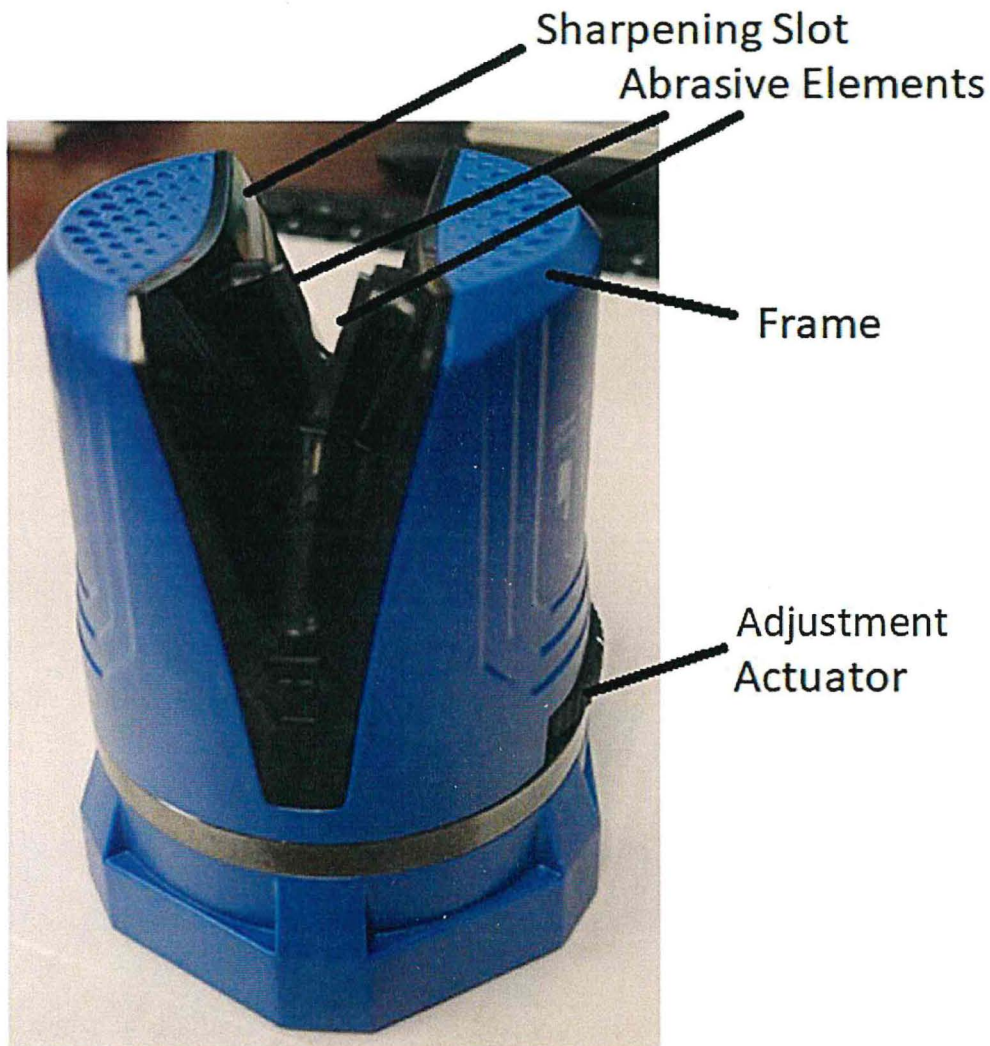

Fig. A

18. The Accused Product includes a rotatable rod, as shown in Fig. B below, that is mounted in, located within, and protected by the frame. The rotatable rod is attached to and rotatable by rotation of the adjustment actuator. When a user rotates the adjustment actuator with

respect to the frame, the rotatable rod is rotated as well. These features correspond to the third element in the body of claim 14.

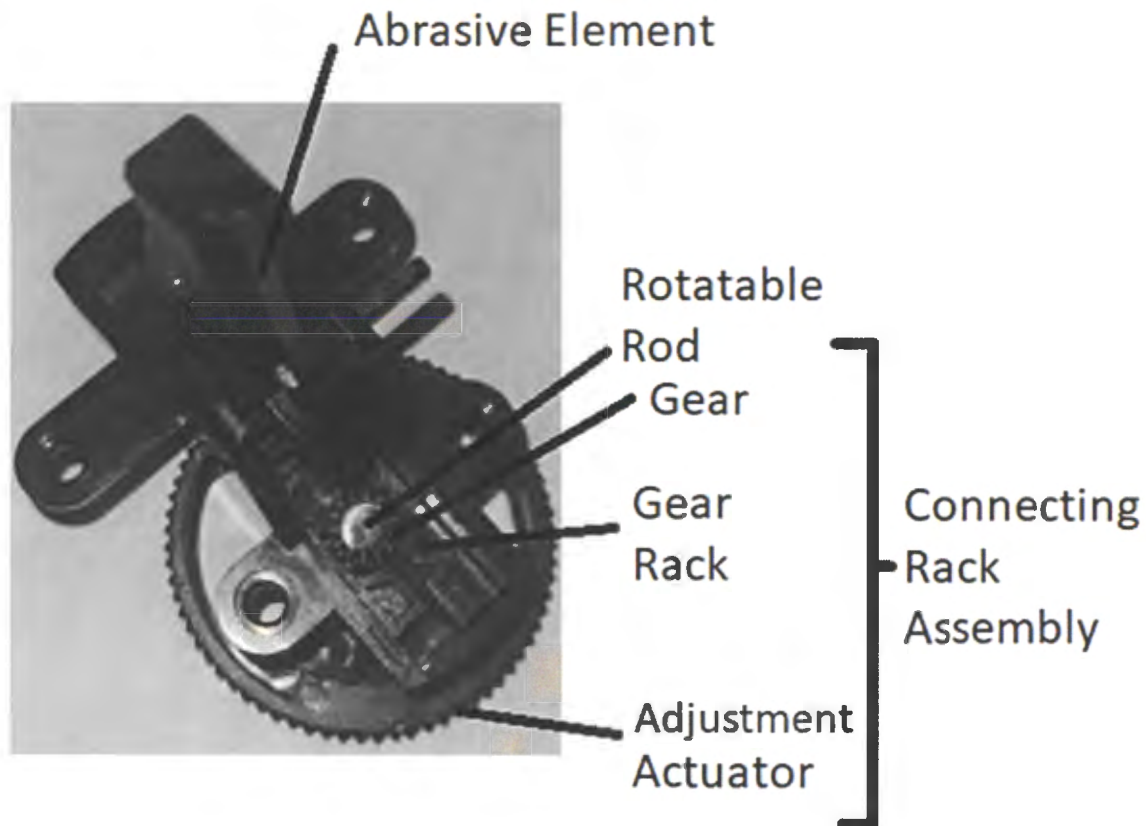

Fig. B

19. The Accused Product includes several components that together form a connecting rack assembly, as shown in Fig. B above. The connecting rack assembly includes two spaced-apart gear racks that operatively connect the adjustment actuator to the abrasive elements. When a user rotates the adjustment actuator, the rod is rotated, which in turn rotates the gear. Teeth of the gear engage teeth of each gear rack. Rotation of the gear moves each gear rack in an opposing axial or linear motion. Axial or linear motion of each gear rack causes each abrasive element to pivot about a pivot point near a bottom end of a blade of each abrasive element. These features correspond to the final element in the body of claim 14.

20. Claim 15 of the '894 patent recites as follows:

The adjustable sharpener according to claim 14 wherein said connecting gear assembly includes at least one gear rack.

21. The Accused Product includes a gear rack, as labeled and shown in Fig. B above, as a component of the connecting rack assembly, which corresponds to claim 15.

22. Claim 16 of the '894 patent recites as follows:

The adjustable sharpener according to claim 15 wherein said rod includes a gear to engage said at least one gear rack.

23. The Accused Product includes a gear that surrounds a portion of, or is attached to, the rotatable rod, as shown in Fig. B above. The gear engages each of the gear racks. These features correspond to claim 16.

24. Plaintiff has suffered injury, including irreparable injury, as a result of Defendants' infringement. Plaintiff is therefore entitled to permanent injunctive relief restraining and enjoining Defendants from infringing the '894 patent.

25. By reason of Defendants' infringement, Plaintiff is suffering and will continue to suffer substantial damages in an amount to be determined at trial.

CLAIM FOR RELIEF
PATENT INFRINGEMENT

26. Plaintiff hereby incorporates by reference the allegations in the preceding paragraphs as if fully set forth herein.

27. The claims of the '894 patent are presumed valid pursuant to 35 U.S.C. § 282.

28. Defendant, in violation of 35 U.S.C. § 271, has been and is currently infringing, contributorily infringing and/or actively inducing others to infringe the '894 patent, either literally or under the doctrine of equivalents, by making, causing to be made, using, offering for

sale, selling, and/or importing into the United States, without license or authority, the infringing products.

PRAYER FOR RELIEF

WHEREFORE, Plaintiff respectfully requests all legal and equitable relief as may be recoverable for the foregoing offenses, including:

- (a) a judgment that Defendants infringe the '894 patent;
- (b) a permanent injunction enjoining Defendants, and those in active concert or participation with it, from infringing the '894 patent;
- (c) an accounting for damages arising from the infringement of the '894 patent by the Defendants and those in privity with it;
- (d) an award of damages adequate to compensate for the infringement of the '894 patent, including, but not limited to, reasonable royalties, lost profits, and damages attributable to price erosion, together with prejudgment and post-judgment interest thereon, and costs fixed by the Court, as provided by 35 U.S.C. § 284;
- (e) pre- and post-judgment interest;
- (f) a declaration that this is an exceptional case and that Plaintiff be granted reasonable attorneys' fees in accordance with 35 U.S.C. § 285; and
- (g) a grant to Plaintiff of any such other relief as the Court may deem just, equitable, or proper.

REQUEST FOR JURY TRIAL

Pursuant to Fed. R. Civ. P. 38, Plaintiff hereby demands a trial by jury on all issues so triable.

Dated: January 19, 2024

Respectfully submitted,

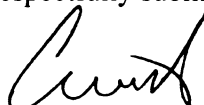

By: Adam L. Hopkins (Ark. #2006282)
ROSE LAW FIRM, P.A.
5100 W. JB Hunt Dr., Suite 900
Rogers, Arkansas 72758
Phone (Direct): (479) 856-6081
ahopkins@roselawfirm.com

David V. Radack (*applying pro hac vice*)
ECKERT SEAMANS CHERIN &
MELLOTT LLC
600 Grant St., 44th Floor
Pittsburg, PA 15219
Phone (Direct): (412) 566-6777
dradack@eckertseamans.com

*Attorneys for Plaintiff Smith's Consumer
Products, Inc.*

EXHIBIT A



US008944894B2

(12) **United States Patent**
Smith et al.

(10) **Patent No.:** US 8,944,894 B2
(45) **Date of Patent:** Feb. 3, 2015

- (54) **ADJUSTABLE ABRASIVE SHARPENER**
- (71) Applicants: **Richard S. Smith**, Hot Springs, AR (US); **Louis Chalfant**, Hot Springs, AR (US)
- (72) Inventors: **Richard S. Smith**, Hot Springs, AR (US); **Louis Chalfant**, Hot Springs, AR (US)
- (73) Assignee: **Smith's Consumer Products, Inc.**, Hot Springs, AR (US)

1,909,743	A *	5/1933	Blankner	451/486
2,519,351	A *	8/1950	Calvert	451/164
2,542,472	A	2/1951	Brinkley	
2,683,385	A	7/1954	Murchison	
2,795,156	A	6/1957	Murchison	
4,235,050	A *	11/1980	Hannaford et al.	451/151
4,807,399	A *	2/1989	Friel	451/45
4,934,110	A *	6/1990	Juranitch	451/486
5,440,953	A *	8/1995	Gangelhoff et al.	76/86
6,866,569	B2 *	3/2005	Cozzini	451/349
6,875,093	B2 *	4/2005	Friel et al.	451/260
6,881,137	B2 *	4/2005	Friel, Sr.	451/349
7,108,595	B2 *	9/2006	Reisinger	451/461
7,121,935	B2 *	10/2006	Pretorius	451/321
7,172,500	B1 *	2/2007	Wu et al.	451/319
8,267,749	B2 *	9/2012	Smith et al.	451/349
2003/0077990	A1 *	4/2003	Li	451/293
2006/0040598	A1 *	2/2006	Koppe	451/349
2007/0281590	A1 *	12/2007	Friel et al.	451/45
2010/0199826	A1 *	8/2010	Ikoma et al.	83/471
2011/0201257	A1 *	8/2011	Walker	451/45

(*) Notice: Subject to any disclaimer, the term of this patent is extended or adjusted under 35 U.S.C. 154(b) by 214 days.

(21) Appl. No.: 13/660,944

(22) Filed: Oct. 25, 2012

(65) **Prior Publication Data**
US 2014/0120812 A1 May 1, 2014

(51) **Int. Cl.**
B24B 19/00 (2006.01)
B24D 15/08 (2006.01)

(52) **U.S. Cl.**
CPC B24D 15/082 (2013.01); Y10S 451/918 (2013.01)
USPC 451/552; 451/45; 451/196; 451/555; 451/918; 76/82; 76/86

(58) **Field of Classification Search**
CPC B24B 3/54; B24B 19/002; B24B 19/001
USPC 451/45, 196, 552, 555; 76/82, 86, 88
See application file for complete search history.

(56) **References Cited**
U.S. PATENT DOCUMENTS

558,407	A	4/1896	Miller	
1,041,631	A *	10/1912	Johnson	451/486
1,170,898	A	2/1916	Hancock	

* cited by examiner

Primary Examiner — George Nguyen
(74) *Attorney, Agent, or Firm* — Edward D. Gilhooly

(57) **ABSTRACT**

An adjustable manual abrasive sharpener having a pair of sharpening slots formed in a frame with opposing abrasive arms being pivotally mounted in each of the sharpening slots. A rod is mounted on the frame for rotatable motion and for linear motion long its axis of rotation from a position at which the rod is locked against rotation to a depressed position whereby the rod may be rotated. The bottom end portion of the rod includes a pinion gear which engages a pair of gear racks which are mounted for movement laterally relative to the axis of rotation of the rod. The pair of gear racks respectively engage slots formed on the bottom of the abrasive arms in each sharpening slot. Rotation of the rod causes movement of the gear racks to adjust each pair of abrasive arms with respect to each other to vary the sharpening angle of the abrasive elements.

19 Claims, 6 Drawing Sheets

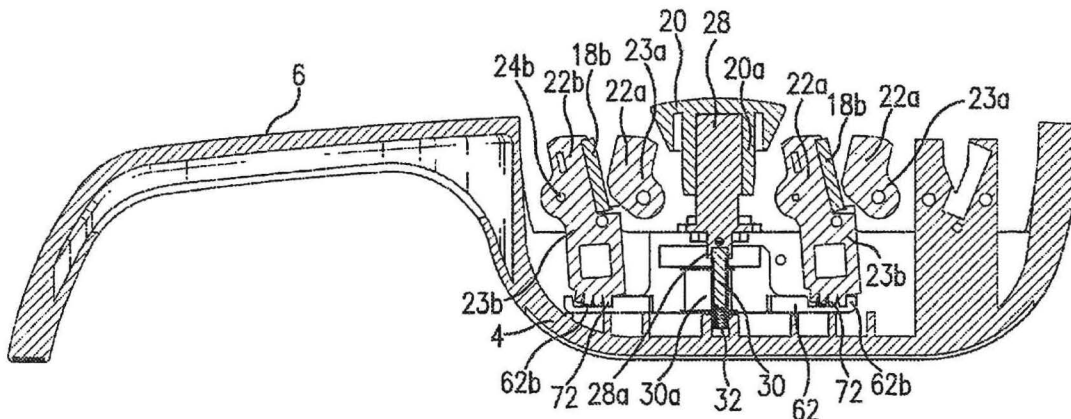

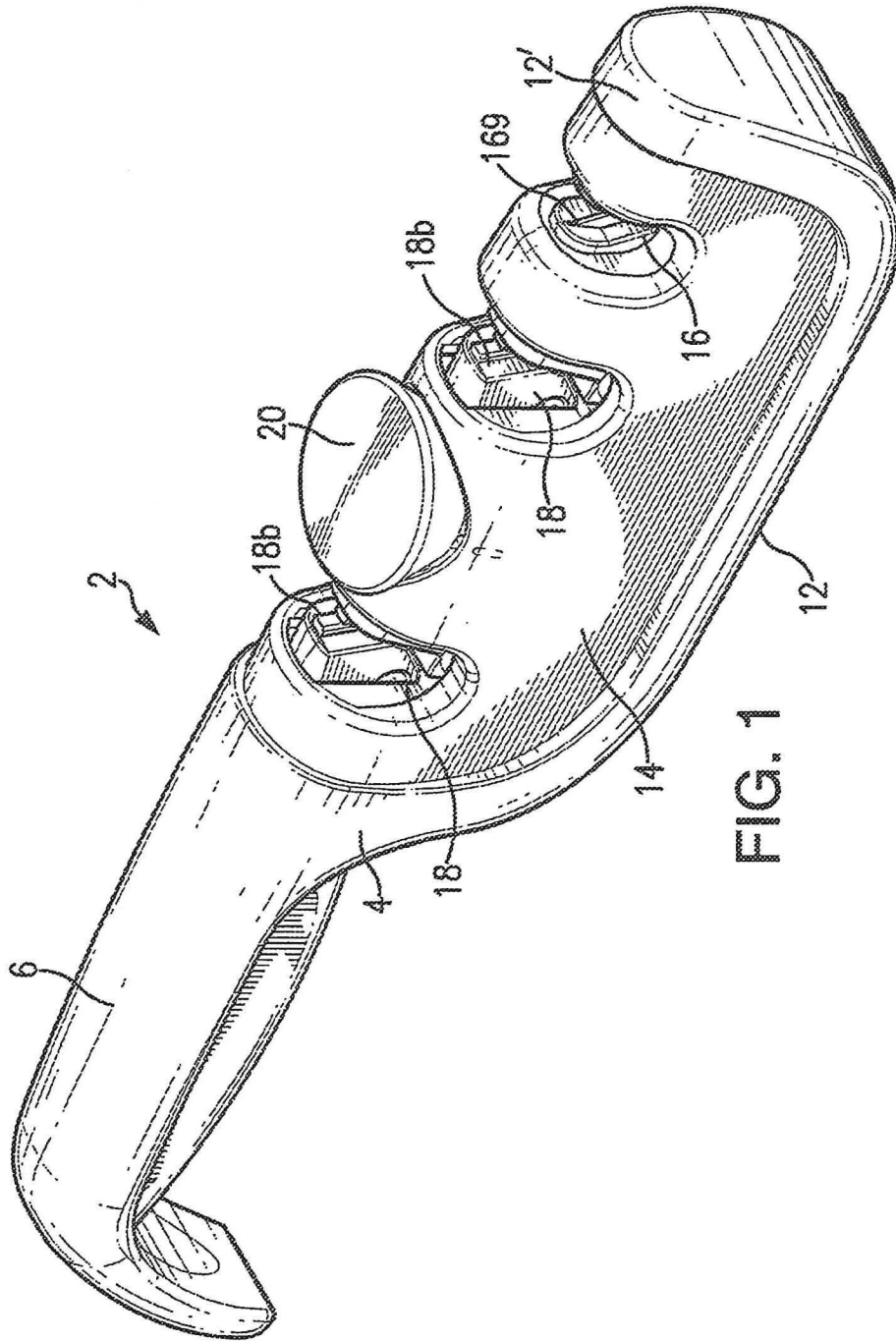

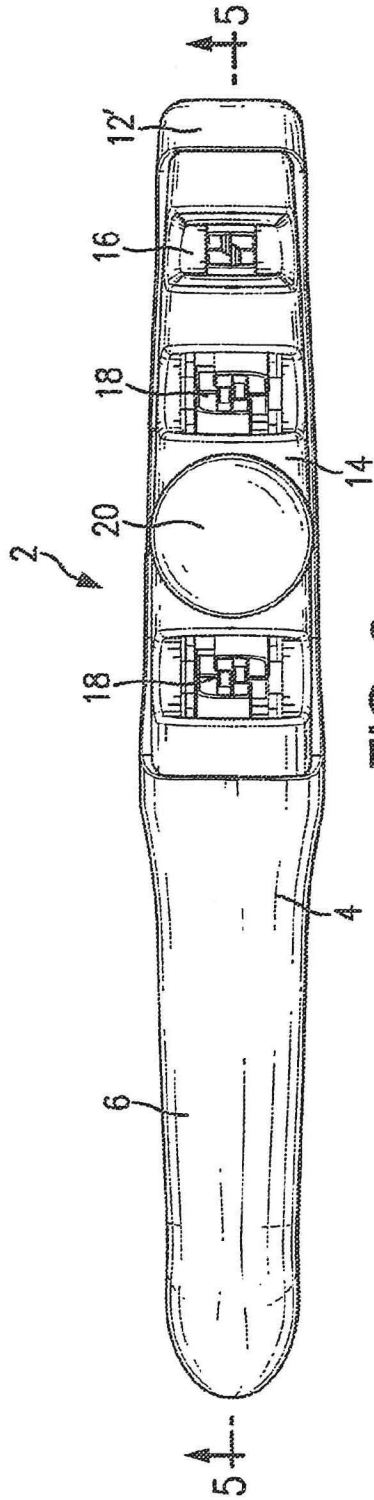

FIG. 2

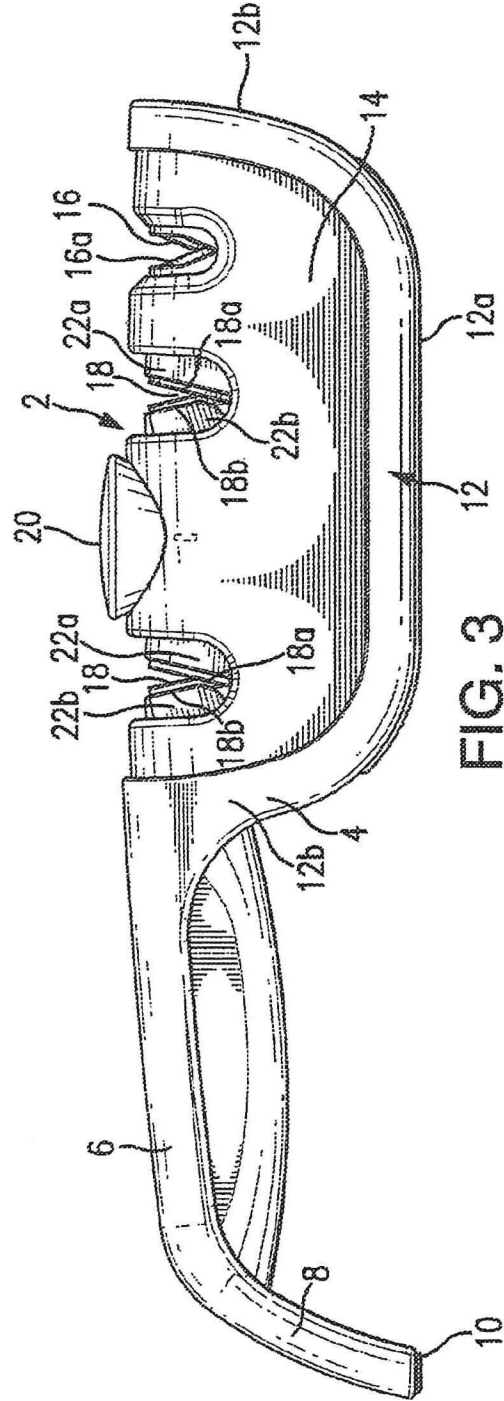

FIG. 3

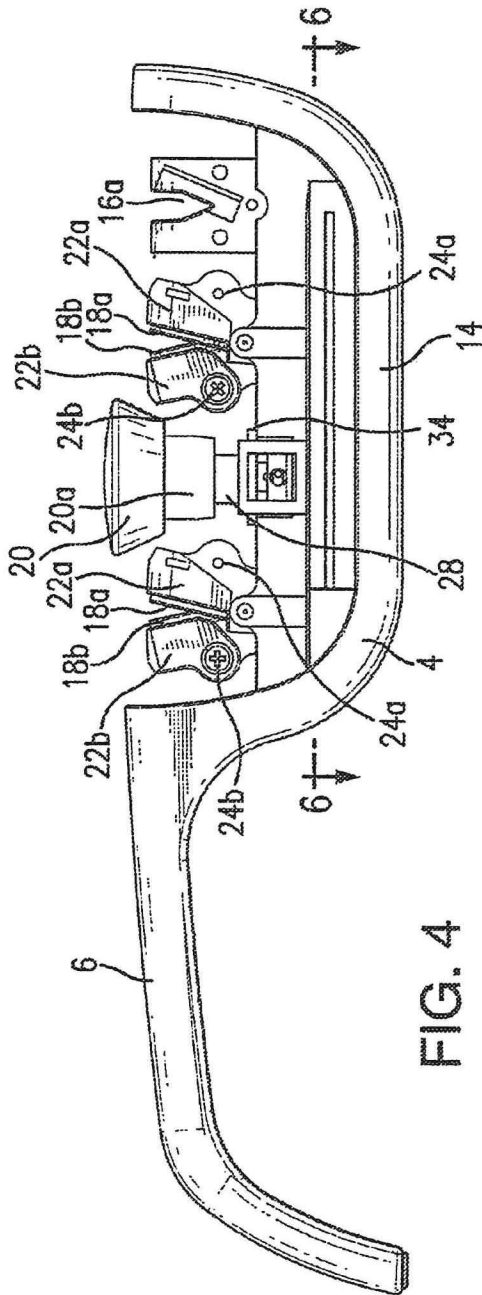

FIG. 4

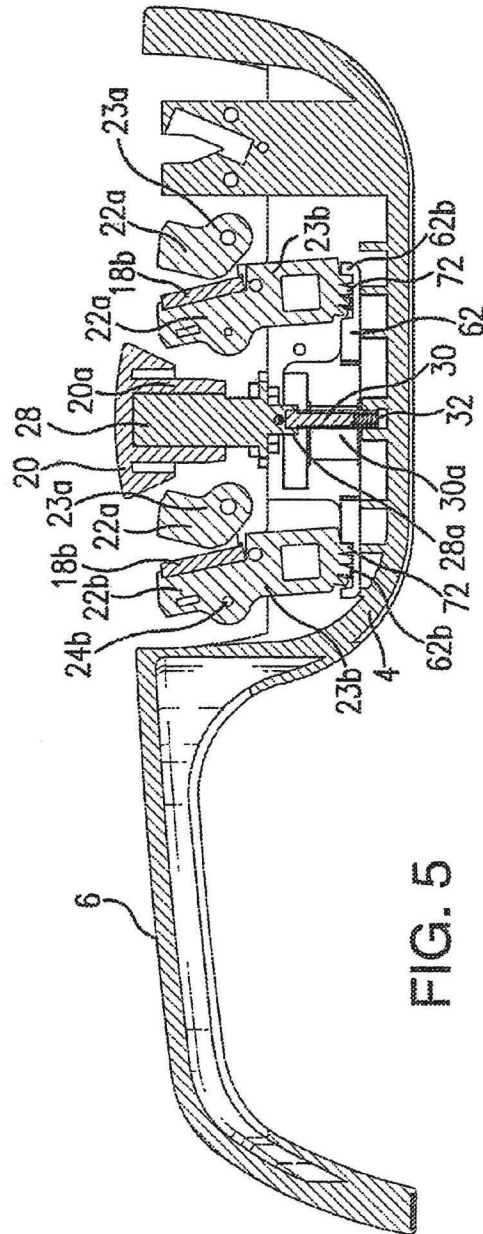

FIG. 5

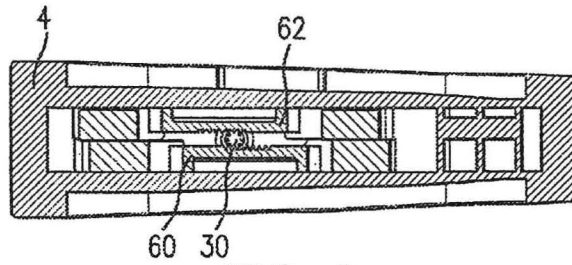

FIG. 6

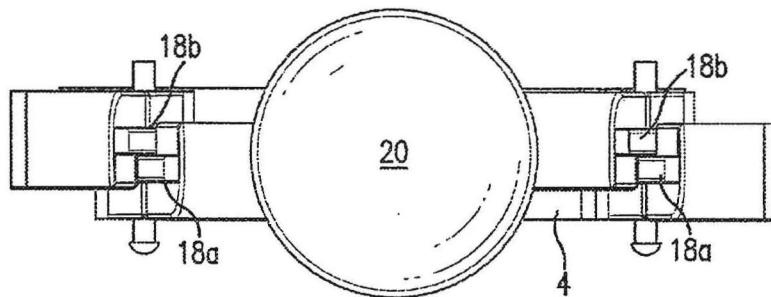

FIG. 7

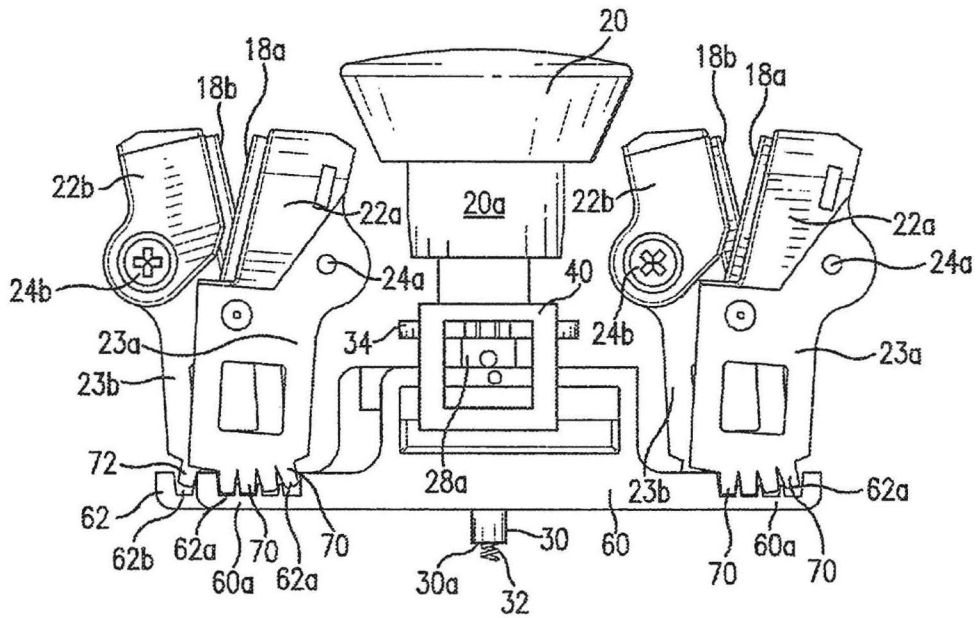

FIG. 8

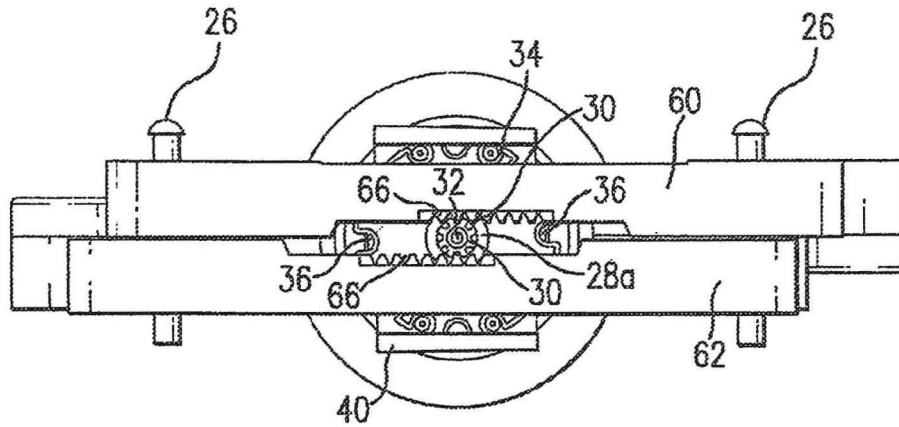

FIG. 9

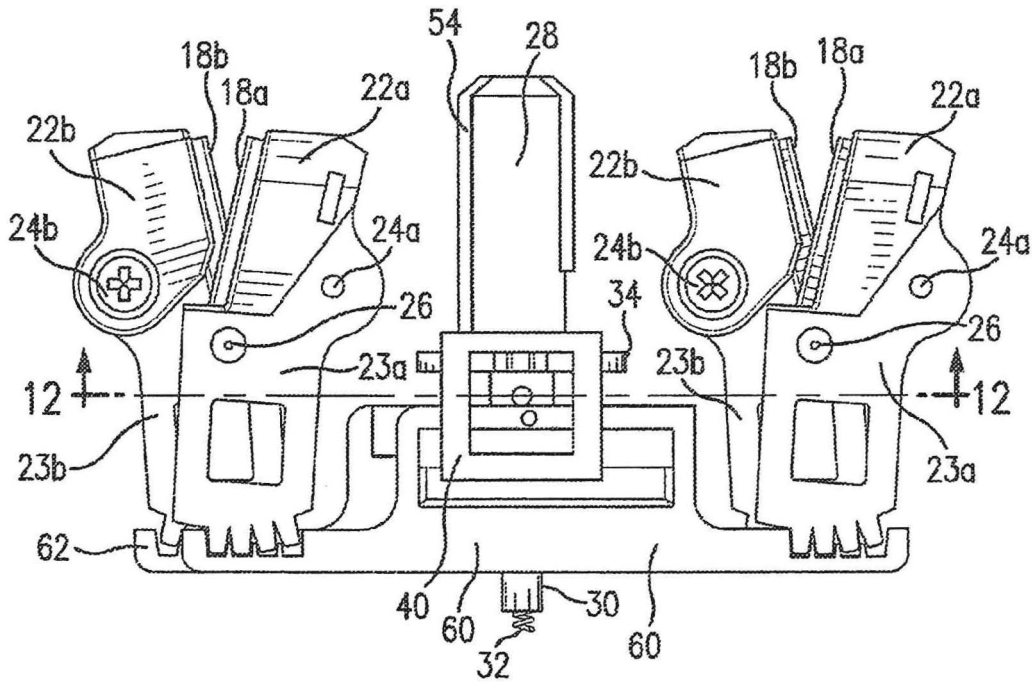

FIG. 10

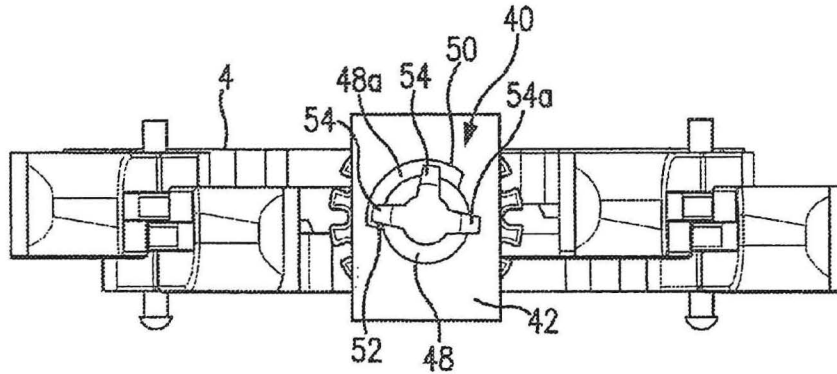

FIG. 11

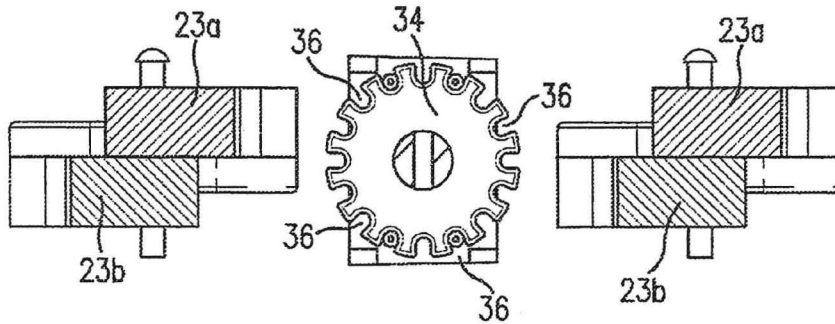

FIG. 12

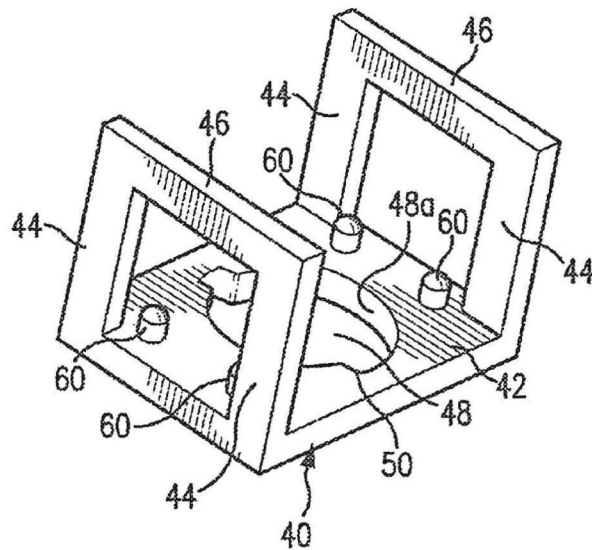

FIG. 13

US 8,944,894 B2

1

ADJUSTABLE ABRASIVE SHARPENER**BACKGROUND OF THE INVENTION**

This application claims priority to provisional application Ser. No. 61/632,038 filed Jan. 17, 2012.

FIELD OF THE INVENTION

This invention relates to sharpening knives and the like, and more particularly, to an improved adjustable abrasive sharpener.

SUMMARY OF THE PRIOR ART

In the prior art numerous abrasive sharpeners for knives and the like exist having fixed abrasive elements forming a V-shaped sharpening slot. Such known fixed abrasive elements are oriented at a fixed angle to sharpen a blade at an angle as desired for a range of different knife types. Most sharpeners are set at either a standard angle and/or an Asian angle that is preset and static. All manufacturers use blades that produce set knife angles that may vary from knife style to another. These varying set angles may not match the standard or santoku angle of prior fixed angle sharpeners. Accordingly, it is desirable in the prior art to provide an adjustable V-shaped sharpener by which the sharpening angle may be varied to range of sharpening angles to more closely match the prescribed sharpening angle of the knife edge from the original blade manufacture.

SUMMARY OF THE INVENTION

It is therefore an objective of the invention to provide an improved abrasive knife sharpener having adjustable abrasive elements to selectively vary the sharpening angle of a blade. The sharpener includes a pair of pivotally mounted abrasive elements forming a sharpening slot whereby the abrasive elements can selectively be moved toward and away from each other to vary their orientation and sharpening angle. Such adjustability is achieved by a rotary adjustment mechanism for ease of use and significant control of the angle between a respective pair of abrasive elements. By varying the angle between the abrasive elements the user may select a sharpening angle that more closely matches the prescribed manufacture specifications.

BRIEF DESCRIPTION OF THE DRAWINGS

FIG. 1 is a front perspective view of the adjustable abrasive sharpener of the invention;

FIG. 2 is a top plan view of the adjustable abrasive sharpener of FIG. 1;

FIG. 3 is a front elevational view of the adjustable abrasive sharpener of FIG. 1;

FIG. 4 is a front elevational view, with the cover removed, of the adjustable abrasive sharpener of FIG. 1;

FIG. 5 is a front elevational view, with parts in section, taken along lines 5-5 of FIG. 2;

FIG. 6 is a top plan view, with parts in section, taken along lines 6-6 of FIG. 4;

FIG. 7 is a top partial plan view of the adjustable arms of the adjustable abrasive sharpener of FIG. 1;

FIG. 8 is a front partial elevational view of the adjustable arms of the adjustable abrasive sharpener of FIG. 1;

FIG. 9 is a bottom partial plan view of the rack and pinion of the adjustable abrasive sharpener of FIG. 1;

2

FIG. 10 is a partial front elevational view, with parts removed, of the adjustable mounting of the abrasive elements of the invention of FIG. 1.;

FIG. 11 is a partial top plan view, with parts removed, of the adjustable mounting of the abrasive elements of the invention of FIG. 1;

FIG. 12 is a bottom partial plan view, taken along lines 12-12 of FIG. 10, of the adjustable arms of the adjustable abrasive sharpener of FIG. 1; and

FIG. 13 is bottom perspective view of the angle locking bracket of the adjustable abrasive sharpener of FIG. 1.

DESCRIPTION OF THE PREFERRED EMBODIMENT

15

Referring now to FIGS. 1-13, there is illustrated the adjustable abrasive sharpener of the invention for sharpening knife blades and the like, generally designated by reference numeral 2. Although the sharpener 2 discloses a manual adjustment of the sharpening angle, it is within the scope of the invention to employ other techniques employing the invention, such as an electro-mechanical mechanism (not shown) and the like. As best seen in FIGS. 1-3, the abrasive sharpener 2 includes an elongated frame 4 forming a handle portion 6 at one end. The end 8 of handle 6 curves downward and includes a flat bottom surface 10 which serves as a support area during sharpening. The frame 4 further includes upwardly opening U-shaped section 12 forming a bottom support surface 12a and a curve upward extending portion 12b (FIGS. 3). A housing 14 is positioned within the U-shaped section 12. A sharpening slot 16 having abrasive elements 16a which are oriented to each other at a generally fixed V-angle is provided on the top of housing 14. A pair of additional slots 18 are formed on the top of housing 14 and each include a pair of pivotally mounted abrasive elements 18a, 18b forming an adjustable generally V-angle to be capable of varying the sharpening angle of the blade of a knife dependent on desired results. As will be apparent from the following description, the abrasive elements 18a, 18b can simultaneously be adjusted toward and away from each other through rotation of exterior adjustment actuator, such as knob 20, which is shown being situated between the two respective slots 18. It is within the scope of the invention, however, to situate the knob 20 on either side of one of the adjustable slots 18 or other desired position where convenient.

30

As previously described, the abrasive elements 18a and 18b in each slot 18 are arranged with respect to each other to form a cutting slot having a generally V-configuration to sharpen an inserted blade edge (not shown) through its movement through the slots 18. The abrasive elements 18a are affixed to a removable support 22a mounted on pivotal arm 23a by a threaded member 24a as seen in FIGS. 4, 5, 8, and 10. The opposing abrasive elements 18b are affixed to a removable support 22b mounted on a removable arm 23b by a threaded member 24b. The pivot arms 22a, 22b of both adjustable slots are pivotally mounted on pivot pin 26. As seen in FIGS. 7, 8, and 11, the arms 23a and 23b are offset from other in a lateral direction relative to the frame 4 and extend downward.

35

The hub 20a of the adjustment knob 20 is suitably secured to a downwardly extending rod 28 having a lower open ended reduced end portion 28a and acting as part of the adjustment actuator of the invention. A lower elongated pinion 30 is secured end portion 28a (FIGS. 5, 6 and 8-10). A spring 32 is disposed between the lower end 30a of pinion 30 and a portion of frame 4 (FIGS. 5, 8, 9 and 10). A circular plate 34 having a plurality of open engagement slots 36 arranged on its

40

45

50

55

60

65

US 8,944,894 B2

3

periphery for an extent of 360° is rigidly mounted on rod 28 (FIGS. 4, 8, 9, and 12). The rod 28, pinion 30, and plate 34 are mounted on frame 4 to be rotated for a predetermined range and be vertical moved a limited degree through use of knob 20 as will be apparent.

As best seen in FIGS. 8, 9, 10, 11 and 13, an angle locking bracket 40 is mounted in fixed relationship on frame 4. As seen in FIG. 13, the angle locking bracket 40 has an upper plate 42 supported on opposed pairs of spaced legs 44 which are interconnected by an opposed based members 46. A modified circular opening 48 is formed in plate 42. A cut-out area 48a exceeding the radius of opening 48 extends from a stop surface 50 to a second stop surface 52 (FIG. 11) limits the amount of rotation of shaft 28 by knob 20. To accomplish the foregoing result, vertical keys 54 exteriorly projecting on rod 28 rotates in cut-out area 48a for maximum angle of rotation as established between stop surfaces 50, 52 (FIGS. 11 and 13). Four engagement pins 60 extend downward from plate 42 of the angle locking bracket 40. In the uppermost position of knob 20 and rod 28 the pins 60 extend into four respective engagement slots 36 of circular plate 34 and lock rod 28 and pinion 30 against rotation. By pressing knob 20 downward to compress spring 32, the locked engagement slots 36 move away from the engagement pins 60 and the rod 28 and pinion 30 can be rotated to the extent determined by stops 50, 52 as they contact keys 54. The extent of rotation determines the adjustment of the sharpening angle between abrasive elements 18a and 18b of both adjustable sharpening slots.

A pair of connecting members 60,62 in the form of adjustment gear racks are mounted by suitable means on frame 4 for relative reciprocal movement in a direction perpendicular to the axis of rotation of rod 28 as seen in FIGS. 6, 8, 9, and 10. The rack 60 includes linear rack gear section 64 which engages pinion 30 at all position vertical positions of rod 28. The rack 62 includes linear rack gear section 66 and engages pinion 30 at all suitable vertical positions of rod 28. The pinion 30 moves the adjustment racks in opposite directions in either direction of rotation of rod 28 when the engagement pins are released. The end portions 60a of adjustment racks 60 include a plurality of upwardly opening slots 62a. The end portions 62a of adjustment racks 62 include a plurality of upwardly opening slots 62b (FIG. 5).

As seen in FIGS. 8 and 10, the bottom of pivot arm 23b is formed in a curvature from which four projections 70 project into corresponding slots 62a for an extent dependent on the rotational position of the pivot arm 23a as established by the relative position of the adjustment rack 60. As seen in FIG. 5, the bottom of pivot arm 23b is formed with a curvature from which four projections 72 extend into a corresponding slots 62a for an extent on the rotational position of the pivot arm 23b as established by the relative position of the adjustment rack 62. From the foregoing it should be apparent that rotation of knob 20 in a clockwise direction moves rack 60 left to the right viewing FIGS. 8 and 9 to pivot arm 23a toward pivot arm 23b. Similarly, clockwise rotation of knob 20 will move adjustment rack 62 from right to left through pinion 30 to pivot arm 23b toward pivot arm 23a. Thus, the angle between abrasive elements 18a and 18b in both slots are varied. To move the pivot arms 23a, 23b away from each other the knob 20 may rotate in a counter clockwise direction viewing FIG. 7. As stated previously, the knob 20 must be depressed to release the engagement in order to permit adjustment rotation of the knob 20. Indicia elements (not shown) may be provided exteriorly adjacent the knob 20 to indicate a range of sharpening angles dependent on the extent of rotation of knob 20 and pinion gear 30. After an angle of sharpening is selected dependent on desired results, the knob is released and spring

4

32 urges automatic upward movement of the rod 28 and circular plate 34 so as the four engagement pins 60 are inserted into four engaging slots 36 which are in alignment with the engagement pins 60 as established by the angular relationship of pivot arms 23a, 23b in a particular adjusted position. The abrasive elements 18a, 18b in the two sharpening slots may have different abrasive properties, such as a coarser and finer abrasive quality.

What is claimed is:

1. An adjustable sharpener comprising
 - a frame having an open sharpening slot,
 - a pair of abrasive elements being mounted in said slot, a pair of abrasive elements being pivotally mounted in said slot to form a generally V-shaped sharpening angle in conjunction with the other of said pair of abrasive elements,
 - an adjustment actuator being mounted on said frame,
 - a connecting assembly being operatively connected between said adjustment actuator and said pair of abrasive elements whereby said actuator causes pivotal movement of said pair of abrasive elements with respect to the other to adjust the sharpening angle of said pair of abrasive elements.
2. The adjustable sharpener according to claim 1 wherein said adjustment actuator includes a rotatable rod mounted on said frame and being operatively connected to said connecting assembly.
3. The adjustable sharpener according to claim 2 wherein said connecting assembly includes at least one gear rack engaging said rotatable rod and said pair of pivotally mounted abrasive elements.
4. The adjustable sharpener according to claim 3 wherein said rotatable rod includes a fixed gear engaging said at least one gear rack.
5. The adjustable sharpener according to claim 3 wherein said pair of pivotally mounted abrasive elements is respectively mounted on an arm assembly, said arm assembly includes a plurality of slots for respectively engaging said at least one gear rack.
6. The adjustable sharpener according to claim 4 wherein said at least one gear rack is moveable generally perpendicular to the axis of rotation of said rotatable rod.
7. An adjustable sharpener comprising
 - a frame having a sharpening slot,
 - a pair of pivotally mounted arms having an abrasive element being mounted in said sharpening slot to form a generally V-shaped sharpening angle with respect to each other,
 - at least one of said pivotally mounted arms being moveable with respect to the other of said pair of pivotally mounted arms to adjust said sharpening angle,
 - a rod operatively mounted for rotatable movement about an axis and being connected to said at least one of said pivotally arm assemblies to cause pivotal movement of said at one of said arm assemblies upon rotation of said rod to adjust said sharpening angle,
 - said rod being mounted on said frame for movement along said axis of rotation from a first position to a second position, and
 - said rod being locked against rotation in said first position and being capable of being rotated in said second position.
8. The adjustable sharpener according to claim 7 wherein said rod causes pivotal movement of both of said pair of pivotally mounted arms upon rotation to adjust said sharpening angle.

US 8,944,894 B2

5

9. The adjustable sharpener according to claim 8 wherein said rod engages a locking bracket in said first position.

10. The adjustable sharpener according to claim 7 further including a resilient member to maintain said rod in first position.

11. The adjustable sharpener according to claim 8 further comprising a gear being mounted on said rod, a pair of connecting members being mounted on said frame, said connecting members engaging said gear and being moveable axially upon rotation of said rod, said connecting members being connected to said pair of pivotally mounted arms to adjust said sharpening angle upon said axial movement.

12. The adjustable sharpener according to claim 11 wherein said pair of connecting members are a pair of gear racks.

13. The adjustable sharpener according to claim 11 further comprising a second open sharpening slot, a second pair of abrasive elements being pivotally mounted in said second slot to form a generally V- shaped sharpening angle in said second slot, said pair of connecting members being connected to said second pair of pivotally mounted arms to adjust said sharpening angle in said second slot upon said axial movement.

14. An adjustable sharpener comprising a frame having an open sharpening slot, a pair of abrasive elements being mounted in said slot to form a generally V- shaped sharpening angle in said slot, at least one of said abrasive elements being mounted for pivotal movement, a rotatable rod being mounted on said frame, and a connecting rack assembly being mounted for axial movement on said frame and being connected between said rod and said at least one of said abrasive elements

6

whereby rotation of said rod effects axial movement of said rack assembly to cause pivotal movement of said at least one of said abrasive elements with respect to the other of said abrasive elements to adjust said sharpening angle form by said pair of abrasive elements.

15. The adjustable sharpener according to claim 14 wherein said connecting gear assembly includes at least one gear rack.

16. The adjustable sharpener according to claim 15 wherein said rod includes a gear to engage said at least one gear rack.

17. The adjustable sharpener according to claim 14 wherein said rotatable rod is moveable along its axis of rotation from a first position locking said rod against rotation to a second position permitting rotation of said rod.

18. The adjustable sharpener according to claim 14 further comprising a second open sharpening slot on said frame, a second pair of abrasive elements being mounted in said second slot to form a generally V- shaped sharpening angle in said second slot, at least one of said abrasive elements being pivotally mounted, said connecting rack assembly being connected to said at least one pivotally mounted abrasive elements to adjust said sharpening angle in said second slot upon said axial movement.

19. The adjustable sharpener according to claim 18 wherein said pair of abrasive elements in said open and second open slots are pivotally mounted said axial movement of said connecting rack assembly simultaneously causes pivotal movement of each of said abrasives element in said open slot and said second open slot.

* * * * *