

Plaintiff, Atlas Global Technologies LLC (“Atlas”), for its Complaint against Defendant Vantiva SA (“Vantiva” or “Defendant”), requests a trial by jury, and alleges as follows upon actual knowledge with respect to itself and its own acts and upon information and belief as to all other matters:

NATURE OF THE ACTION

1. This is an action for patent infringement brought by Atlas as the owner of the patents asserted in this Complaint. Atlas alleges that Defendant infringes U.S. Patent Nos. 9,531,520 (“the ’520 Patent”); 9,628,310 (“the ’310 Patent”); 9,641,234 (“the ’234 Patent”); 9,832,058 (“the ’058 Patent”); 9,848,442 (“the ’442 Patent”); 9,893,790 (“the ’790 Patent”); 10,020,919 (“the ’919 Patent”); 10,327,172 (“the ’172 Patent”); and 11,050,539 (“the ’539 Patent”) (collectively, the “Asserted Patents”).

2. Atlas alleges that Defendant both directly and indirectly infringes each of the Asserted Patents. Defendant directly infringes the method claims of the Asserted Patents by using the Accused Products (described below) in the United States without a license. Defendant directly infringes the apparatus claims of the Asserted Patents by making, using, offering to sell, selling and/or importing the Accused Products in the United States without a license.

3. In addition to its direct infringement, Defendant indirectly infringes the method claims of the Asserted Patents by inducing third parties—including Defendant’s customers and end-users of Defendant’s products—to use the Accused Products in the United States in a manner that directly infringes the Asserted Patents, per the directions and instructions provided by Defendant to its customers and end users. Defendant also indirectly infringes the apparatus claims of the Asserted Patents by inducing others—including Defendant’s affiliates, partners, customers, and end-users of Defendant’s products—to make, use, sell, offer to sell, and/or import the Accused Products in the United States in an infringing manner, as directed and instructed by Defendant.

4. Atlas seeks damages and other compensatory relief for Defendant’s prior and continued infringement of the Asserted Patents.

THE PARTIES

5. Atlas is a limited liability company organized under the laws of Texas with its principal place of business at 4413 Spicewood Springs Rd., Suite 101, Austin, TX 78759.

6. Atlas is the assignee and owner of the Asserted Patents through assignment on February 19, 2021, from Newracom, Inc., (“Newracom”) to Atlas. Newracom was the original owner of the Asserted Patents though assignment from the named inventors.

7. On information and belief, defendant Vantiva SA is a French corporation with its principal place of business at 8-10 Rue Du Renard, Paris 75004, France.

8. On information and belief, Defendant is engaged in research and development, manufacturing, importation, distribution, sales, and related technical services for wireless devices, including particularly devices designed to operate on Wi-Fi 6 networks consistent with the Wi-Fi 6 (or 802.11ax) protocols. Defendant’s Wi-Fi 6 products are used and sold in the United States, and throughout Texas, including in this District.

9. On information and belief, Defendant is engaged in research and development, manufacturing, importation, distribution, sales, and related technical services for home and business networks, including particularly devices designed to operate on Wi-Fi 6 networks consistent with the Wi-Fi 6 (or 802.11ax) protocols. Defendant’s Wi-Fi 6 products are made outside the United States of America and then are imported into the United States, distributed, and sold to end-users via the Internet and via distribution partners, retailers, reseller partners, and solution partners. Those sales occur in the United States, and throughout Texas, including in this District. Defendant represents to its customers that it is “a world-class, truly global team operating 24/7 across timezones [sic] and on every continent” that includes the United States. <https://www.vantiva.com/who-we-are/> (last visited Feb. 1, 2024).

10. Defendant affirmatively touts Wi-Fi 6 technology and its advantages to its prospective customers who purchase Wi-Fi 6 products. For example, Defendant tells its customers that “Wi-Fi 6 has established itself globally as the mainstream standard for operators who want to offer their customers multi-device, high performance connectivity at the most competitive price.”

<https://www.vantiva.com/resources/wi-fi-6-infographics-the-most-mainstream-standard/> (last visited Feb. 5, 2024). According to this Vantiva website, “Wi-Fi 6 has taken over as the worldwide reference for device connectivity” and “is indispensable for connected homes.” Vantiva explains that there are over 20+ connected devices per household in 2024, almost double the average number of connected devices that were typically used in 2019. *Id.*

11. According to Defendant, Wi-Fi 6 provides multi-device connection by “leveraging MU-MIMO & OFDMA to connect more devices.” *Id.* Defendant also touts other improvements provided by Wi-Fi 6, including reduced interference, improved battery life, and faster connections with better coverage, all while maintaining backwards compatibility with prior Wi-Fi standards.

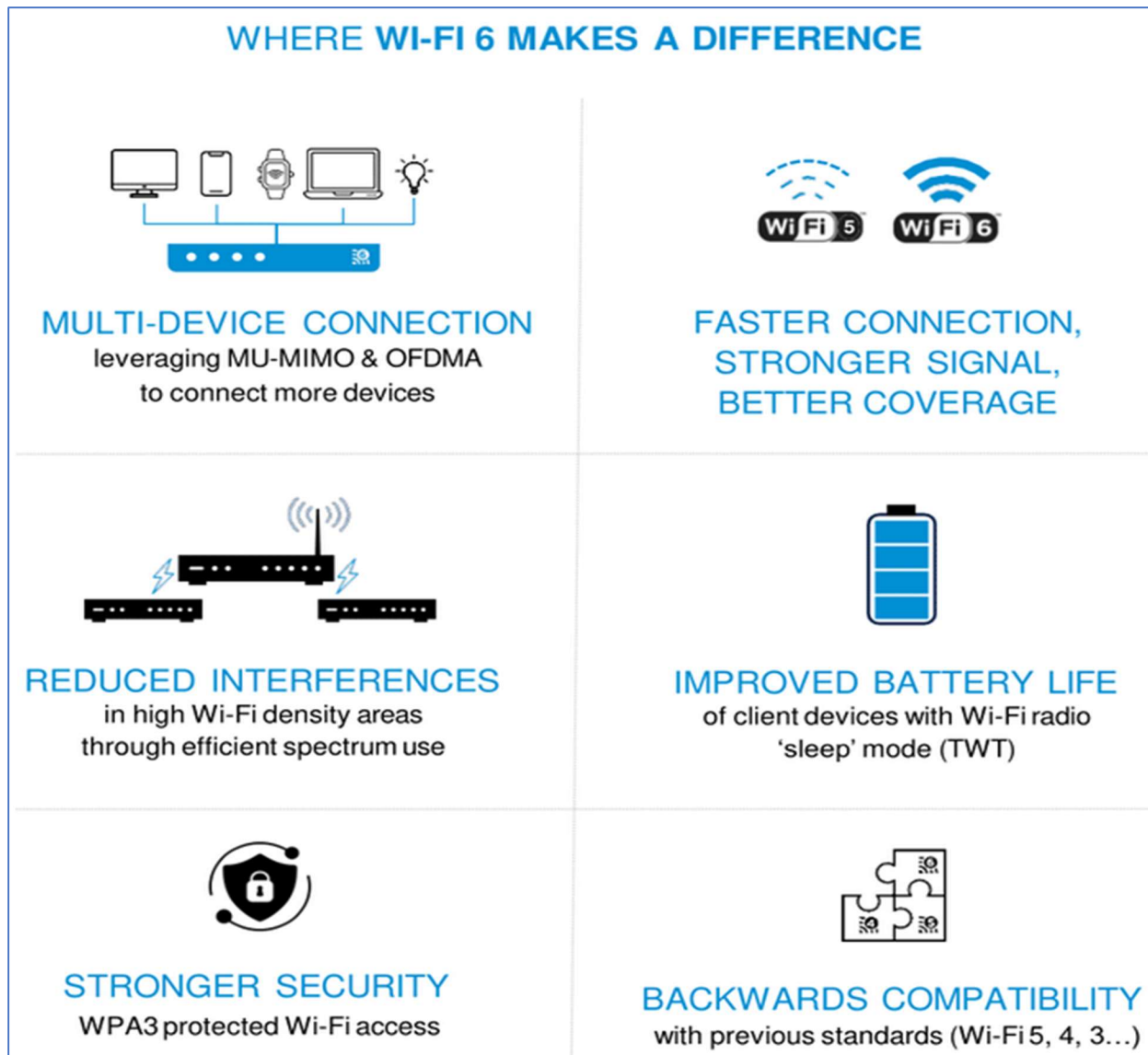

Id. Defendant also explains that “Wi-Fi 6 presents a major opportunity for Network Service Providers, radically improving service quality levels, especially for users in high density Wi-Fi areas. While remaining backwards compatible with previous standards (802.11ac, 802.11n, et. al.), Wi-Fi 6 increases signal strength, reduces interference, and improves power usage. Ultimately, Wi-Fi 6 represents a dramatic step forward in providing a better User Experience, which can lead to improved business metrics for service providers, reducing churn and increasing the Lifetime Value of their subscriber base.” Vantiva “Video Over Wi-Fi 6” whitepaper, available at <https://www.vantiva.com/resources/video-over-wi-fi-6-what-you-need-to-know/> (last visited Feb. 29, 2024).

JURISDICTION

12. This is an action arising under the patent laws of the United States, 35 U.S.C. §§ 1, *et seq.* Accordingly, this Court has subject matter jurisdiction pursuant to 28 U.S.C. §§ 1331 and 1338(a).

13. This Court has personal jurisdiction over Defendant. Atlas is informed and believes, and on that basis alleges, that Defendant conducts business and has committed acts of patent infringement and/or has induced acts of patent infringement by others in this judicial district, the State of Texas, and elsewhere in the United States. Defendant has purposefully directed infringing activities at residents of the State of Texas, and this litigation results from those infringing activities. Defendant also regularly sells (either directly or indirectly), its products within this district. For example, Defendant has placed and continues to place infringing products into the stream of commerce via an established distribution channel, such as its partner networking solution providers, with the knowledge or understanding that such products are being and will continue to be sold in this Judicial District and the State of Texas. Defendant is subject to this Court's specific and/or general personal jurisdiction pursuant to due process and/or the Texas Long Arm Statute, due at least to its substantial and pervasive business in this State and judicial district, including at least part of its infringing activities alleged herein and deriving substantial revenue from goods sold to Texas residents.

14. Upon information and belief, Defendant is subject to this Court's specific and general personal jurisdiction pursuant to due process and/or the Texas Long Arm Statute, based on its substantial business activities conducted in the State of Texas and this Judicial District, including: (1) its infringing activities, as alleged herein, by which Defendant purposefully avails itself of the privilege of conducting its business activities in this State and this Judicial District and, thus, submits itself to the jurisdiction of this Court; and (2) regularly doing or soliciting business, engaging in other persistent conduct targeting residents of Texas and this Judicial District, and/or deriving substantial revenue from infringing goods offered for sale, sold, and imported to and targeting Texas residents and residents of this Judicial District vicariously through and/or in concert with its alter egos, intermediaries, agents, distributors, importers, customers, subsidiaries,

and/or consumers. Such a presence furthers the development, design, manufacture, importation, distribution, sale, and use (including by inducement) of infringing Accused Products in Texas, including in this District. For example, Defendant (and its predecessor Technicolor S.A.) designs and manufactures Wi-Fi 6 routers provided by Google to its Internet customers in Austin, TX:



<https://fccid.io/G95EWA322T/Label/Label-Sample-6728260.pdf> (last visited Feb. 7, 2024); *see also* <https://fiber.google.com/wifi/> (last visited Feb. 1, 2024); <https://fiber.google.com/cities/austin/> (last visited Feb. 1, 2024). Technicolor, the designer of the Wi-Fi 6 product provided by Google Fiber, changed its corporate name to Vantiva in September 2022. *See* <https://www.technicolor.com/news/technicolor-officially-becomes-vantiva> (last visited Feb. 5, 2024). Further, Technicolor has obtained Wi-Fi 6 Certifications for at least some of its routers, including those made specifically for the cable, DSL, and broadband gateway markets. *See e.g.* Certification ID: WFA114527; *see also* Certification ID: WFA97615 (Access Point for Home or Small Office); Certification ID: WFA9114001 (Easy Mesh).

15. This Court has personal jurisdiction over Defendant, directly and/or through the activities of Defendant's intermediaries, agents, related entities, distributors, importers, customers, subsidiaries, and/or consumers. Through direction and control of these various entities, Defendant

has committed acts of direct and/or indirect patent infringement within Texas and elsewhere within the United States, giving rise to this action and/or has established minimum contacts with Texas such that personal jurisdiction over Defendant would not offend traditional notions of fair play and substantial justice.

16. Upon information and belief, Defendant, directly via its agents and distribution partners, retailers (including national retailers), reseller partners, solution partners, brand ambassadors, and other service providers in the U.S., has placed and continues to place infringing Accused Products into the U.S. stream of commerce. Defendant has placed such products into the stream of commerce with the knowledge and understanding that such products are, will be, and continue to be sold, offered for sale, and/or imported into this Judicial District and the State of Texas. *See Litecubes, LLC v. Northern Light Products, Inc.*, 523 F.3d 1353, 1369-70 (Fed. Cir. 2008) (“[T]he sale [for purposes of § 271] occurred at the location of the buyer.”); *see also Semcon IP Inc. v. Kyocera Corporation*, No. 2:18-cv-00197-JRG, 2019 U.S. Dist. LEXIS 74904, at *6–*8 (E.D. Tex. May 3, 2019) (purchases of infringing products outside of the United States for importation into and sales to end users in the U.S. may constitute an offer to sell under § 271(a)).

17. Defendant utilizes established distribution channels to distribute, market, offer for sale, sell, service, and warrant infringing products directly to consumers and other users in the United States, including providing Defendant’s Accused Products to Internet service providers, distributors, and solution partners offering such products and related services for sale. On information and belief, Defendant’s Accused Products have been provided to Internet customers in Texas and specifically within this Judicial District as illustrated in Paragraph 14 above.

18. Based on Defendant’s connections and relationship with these retailers and distributors, Defendant knows that Texas is a termination point of its established distribution channels, including Internet service providers such as Google Fiber offering Accused Products to users in Texas. Defendant, therefore, has purposefully directed its activities at Texas, and should reasonably anticipate being brought into this Court, at least on this basis. *See ICON Health & Fitness, Inc. v. Horizon Fitness, Inc.*, No. 5:08-cv-26, 2009 U.S. Dist. LEXIS 34767, at *40 (E.D.

Tex. Mar. 26, 2009) (“[a]s a result of contracting to manufacture products for sale in” national retailers’ stores, the defendant “could have expected that it could be brought into court in the states where [the national retailers] are located”).

19. These suppliers and distributors import, advertise, offer for sale, and sell Defendant’s Accused Products via their websites to U.S. consumers, including to consumers in Texas. Based on Defendant’s connections and relationships, including supply contracts and other agreements with the U.S. distributors and suppliers, Defendant knows and has known that Texas is a termination point of the established distribution channels for infringing Accused Products. Defendant has purposefully directed its activities at Texas, and should reasonably anticipate being brought in this Court, at least on this basis. *See Ultravision Techs., LLC v. Holophane Eur. Ltd.*, No. 2:19-cv-00291, 2020 U.S. Dist. LEXIS 112148, at *13-14 (E.D. Tex. Apr. 23, 2020) (finding sufficient to make a prima facie showing of personal jurisdiction allegations that “Defendants either import the products to Texas themselves or through a related entity”); *see also Bench Walk Lighting LLC v. LG Innotek Co.*, 530 F. Supp. 3d 468, 485-87 (D. Del. 2021) (denying motion to dismiss for lack of personal jurisdiction based on the foreign defendant entering into supply contract with U.S. distributor and the distributor sold and shipped Defendant’s products from the U.S. to a customer in the forum state).

20. In the alternative, this Court has personal jurisdiction over Defendant under Federal Rule of Civil Procedure 4(k)(2), because the claims for patent infringement in this action arise under federal law; Defendant is not subject to the jurisdiction of the courts of general jurisdiction of any state; and exercising jurisdiction over Defendant is consistent with the U.S. Constitution.

VENUE

21. Venue is proper in this judicial district pursuant to 28 U.S.C. § 1400(b), 28 U.S.C. § 1391(c), and *Brunette Mach. Works, Ltd. v. Kockum Indus., Inc.*, 406 U.S. 706 (1972). Venue is proper in this judicial district pursuant to 28 U.S.C. § 1391(c)(3) because, among other things, Defendant is not a resident of the United States, and thus may be sued in any judicial district,

including this one. *See also In re HTC Corp.*, 889 F.3d 1349, 1357 (Fed. Cir. 2018) (“The Court’s recent decision in *TC Heartland* does not alter” the alien-venue rule.).

22. On information and belief, Defendant also has significant ties to, and presence in, the State of Texas and the Western District of Texas, making venue in this judicial district both proper and convenient for this action. *See supra* ¶¶ 13-19.

23. Venue is also convenient in this district and division because this Court is familiar with the Asserted Patents, which have been asserted in numerous cases. *Atlas Global Techs. LLC v. Sercomm Corp.*, No. 6:21-cv-818 (W.D. Tex.); *Atlas Global Techs. LLC v. ASUSTeK Computer Inc.*, No. 6:21-cv-820 (W.D. Tex.); *Atlas Global Techs. LLC v. OnePlus Tech. (Shenzhen) Co.*, No. 6:21-cv-1217 (W.D. Tex.); *Atlas Global Techs. LLC v. Zyxel Networks Corp.*, No. 6:22-cv-355 (W.D. Tex.); *Atlas Global Techs. LLC v. D-Link Corp.*, No. 6:22-cv-520 (W.D. Tex.); *Atlas Global Techs. LLC v. HP Inc.*, No. 6:23-cv-349 (W.D. Tex.); *Atlas Global Techs. LLC v. Dell Techs. Inc.*, No. 6:23-cv-350 (W.D. Tex.). This Court has already issued claim construction orders in five of those cases. *Atlas Global Techs. LLC v. Sercomm Corp.*, No. 6:21-cv-818, ECF Nos. 78, 84 (W.D. Tex.); *Atlas Global Techs. LLC v. ASUSTeK Computer Inc.*, No. 6:21-cv-820, ECF Nos. 68, 75 (W.D. Tex.); *Atlas Global Techs. LLC v. OnePlus Tech. (Shenzhen) Co.*, No. 6:21-cv-1217, ECF No. 71 (W.D. Tex.); *Atlas Global Techs. LLC v. Zyxel Networks Corp.*, No. 6:22-cv-355, ECF No. 53 (W.D. Tex.); *Atlas Global Techs. LLC v. D-Link Corp.*, No. 6:22-cv-520 ECF No. 41 (W.D. Tex.).

THE 802.11 STANDARD

24. Wireless Local Area Networks (WLANs) have become ubiquitous with the rise of mobile telecommunication devices. These wireless networks operate using the unlicensed 2.4 GHz, 5 GHz, and/or 6 GHz bands. The operation of WLANs is standardized by the Institute of Electrical and Electronics Engineers (“IEEE”) Part 11 under the name of “Wireless LAN Medium Access Control (MAC) and Physical Layer (PHY) Specifications,” also known as “Wi-Fi.”

25. After an original Wi-Fi standard was published in 1997, new standard versions have been published by amendments. For example, the IEEE standard 802.11a (IEEE Std 802.11a-1999) was

published in 1999, the IEEE standard 802.11b (IEEE Std 802.11b-1999) was published in 1999, and the IEEE standard 802.11g (IEEE Std 802.11g-2003) was published in 2003. Subsequently, the IEEE standard 802.11n (IEEE Std 802.11n-2009) for enhancements for higher throughput (HT) was published in 2009, and the IEEE standard 802.11ac (IEEE 802.11-ac-2013) for enhancements for very high throughput (VHT) was published in 2013. These prior versions of the 802.11 standard are called legacy standards.

26. As wireless devices proliferated, the need arose to improve the performance of Wi-Fi in high-density scenarios. To address this issue, an IEEE task group began working on a new standard high efficiency (HE) WLAN to enhance the throughput-per-area of Wi-Fi. This standard became known as 802.11ax, commonly called “Wi-Fi 6.” The first draft of the 802.11ax Standard was published in March 2016. The IEEE approved the final version of the 802.11ax-2021 Standard on February 9, 2021.

27. Wi-Fi 6 provides numerous benefits over previous Wi-Fi standards, which the industry has recognized and actively promoted. Defendant touts that its Wi-Fi 6 products provide a “faster connection, stronger signal, and better coverage” than previous generations of Wi-Fi. <https://www.vantiva.com/resources/wi-fi-6-infographics-the-most-mainstream-standard/> (last visited Feb. 5, 2024). Nor is Defendant alone in touting the advantages of Wi-Fi 6 (802.11ax). For example, Qualcomm has stated that Wi-Fi 6 provides “up to 4x increase in capacity,” “higher efficiency,” and “improved coverage & performance” over previous Wi-Fi standards. <https://www.qualcomm.com/media/documents/files/802-11ax-wi-fi-with-unprecedented-capacity.pdf> (last visited Feb. 29, 2024). Intel has stated that Wi-Fi 6 offers 9.6 Gbps of maximum throughput, whereas Wi-Fi 5 offered a maximum throughput of 3.5 Gbps. <https://www.intel.com/content/www/us/en/gaming/resources/wifi-6.html> (last visited Feb. 29, 2024). Intel has also stated that Wi-Fi 6 can result in up to 75% less latency. *Id.* Cisco has stated that Wi-Fi 6 “lets access points support more clients in dense environments and provide[s] a better experience for typical wireless LAN networks.” <https://www.cisco.com/c/en/us/products/collateral/wireless/white-paper-c11-740788.html> (last

visited Feb. 29, 2024). Broadcom has stated that Wi-Fi 6 will allow devices to “work 6X faster,” “deliver up to 7X better battery life,” and “expand the Wi-Fi range up to 4X.” <https://docs.broadcom.com/doc/80211ax-WP> (last visited Feb. 29, 2024). Broadcom touts the advantages of 802.11ax relative to prior versions of the Standard, noting “While previous Wi-Fi standards were designed to maximize peak speeds for a limited number of devices and users, this standard improves user experience in dense environments by maximizing average speeds for a large number of devices while preserving the benefits of legacy Wi-Fi technologies, such as backwards compatibility and low cost.” *Id.* According to Broadcom, IEEE 802.11ax achieves these advancements through various primary features, including Orthogonal Frequency Division Multiplexing Multiple Access (OFDMA), which increases spectrum capacity by slicing channels into smaller chunks, which together host multiple devices simultaneously; Multi-User MIMO (MU-MIMO) technology to increase channel capacity when simultaneously servicing multiple devices using the same frequency chunks; smarter access points capable of providing improved outdoor connectivity through longer guard intervals. *Id.* Among the various improvements obtained from 802.11ax, outdoor devices that implement 802.11ax can obtain increased throughput of 50% relative to prior versions of the Standard. *Id.*

28. According to Vantiva, Wi-Fi 6 also “leverag[es] MU-MIMO & OFDMA to connect more devices.” <https://www.vantiva.com/resources/wi-fi-6-infographics-the-most-mainstream-standard/> (last visited Feb. 5, 2024). Key benefits of Wi-Fi 6 include “reduced interferences,” “improved battery life,” and “stronger security” over previous generations. *Id.* Defendant touts these benefits to customers and distributors looking for a new device. Vantiva also touts that “Wi-Fi 6 presents a major opportunity for Network Service Providers, radically improving service quality levels, especially for users in high density Wi-Fi areas. While remaining backwards compatible with previous standards (802.11ac, 802.11n, et. al.), Wi-Fi 6 increases signal strength, reduces interference, and improves power usage. Ultimately, Wi-Fi 6 represents a dramatic step forward in providing a better User Experience, which can lead to improved business metrics for service providers, reducing churn and increasing the Lifetime Value of their subscriber base.”

Vantiva “Video Over Wi-Fi 6” whitepaper, available at <https://www.vantiva.com/resources/video-over-wi-fi-6-what-you-need-to-know/> (last visited Feb. 29, 2024).

29. Vantiva also produced a video titled “Premium Wi-Fi 6 Experience” where Vantiva explained that it was “no surprise that Wi-Fi 6 is being rapidly adopted.” <https://www.youtube.com/watch?v=wcWFuJEJtcI> (last visited Feb. 29, 2024). Indeed, Vantiva explicitly targets its Wi-Fi 6 products at the United States (including the Tri-Band Extender Wi-Fi 6 4+4 to Texas):

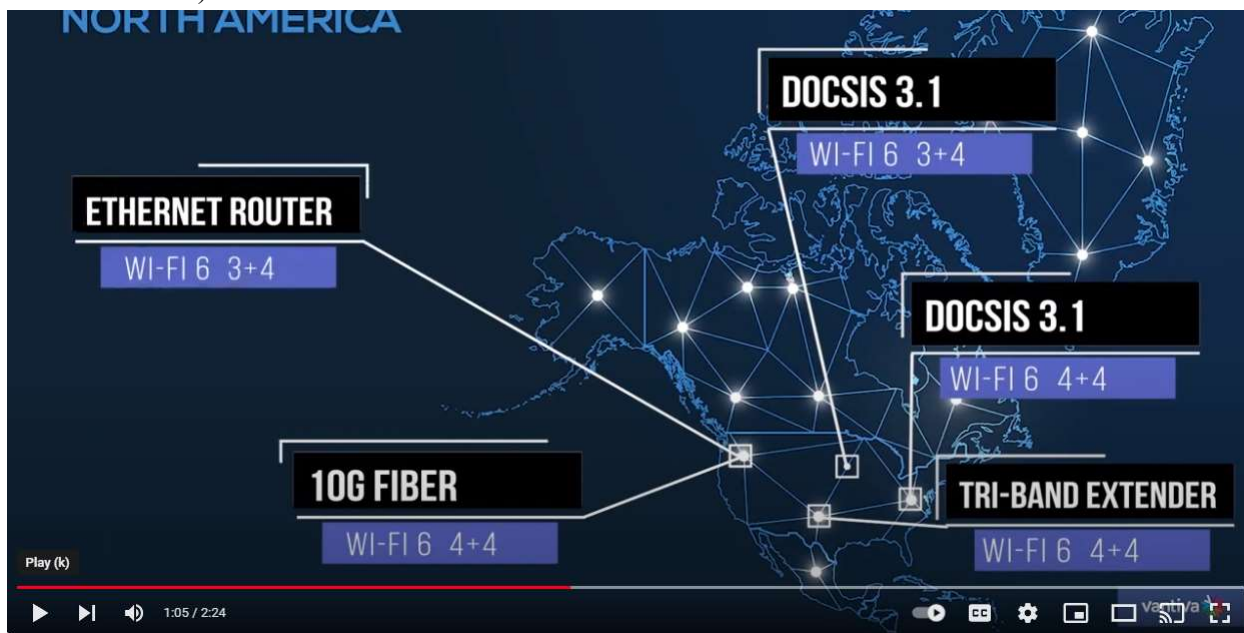

Id. Another of Defendant’s videos explains that: “Our home gateways and extenders embed Wi-Fi 6, the latest revolutionary technology that delivers higher throughput in very dense environments, drastically increases the transmission speed, reduces latency, and lowers the power requirements for client devices.” <https://youtu.be/CGnK2r2WH-k> (last visited Feb. 5, 2024).

NEWRACOM

30. The Asserted Patents were all invented and developed by engineers at Newracom, a leader and pioneer in wireless communication technology. Newracom was founded in 2014 by a group of 28 former employees of the Electronics & Telecommunications Research Institute (“ETRI”), a research institution funded by the government of South Korea.

31. Newracom was a major contributor to the 802.11ax-2021 Standard, providing numerous technical contributions to that Standard that have proven to be highly beneficial in improving the bandwidth of wireless transmissions, while minimizing latency among the devices connected to the wireless local area network. Notably, Newracom has been acknowledged as one of the leaders in both number of technical submissions and the number of submissions ultimately adopted by the 802.11ax Task Group. According to an IAM Industry Report dated April 25, 2018, Newracom was recognized as the world’s fourth most active technical contributor to the 802.11ax Standard, behind only Qualcomm, Intel, and Huawei. See <https://www.iam-media.com/ieees-empirical-record-success-and-innovation-following-patent-policy-updates> (last visited Feb. 29, 2024). The contributions provided by Newracom have led to over 188 United States patents relating to the 802.11ax Standard.

DEFENDANT’S KNOWLEDGE OF NEWRACOM’S PATENTS

32. Defendant has known that Newracom possessed patents relating to the 802.11ax Standard since at least March 11, 2015. On that date, Newracom submitted a Letter of Assurance for Essential Patent Claims (“LOA”) to the IEEE. In the LOA, Newracom stated that it “may own, control, or have the ability to license Patent Claims that might be or become Essential Patent Claims.” As a company in the wireless electronics space, and more particularly a manufacturer of Wi-Fi 6 products, Defendant is familiar with the 802.11ax Wi-Fi 6 Standard and process for submitting letters of assurance. On information and belief, Defendant monitors those letters of assurance, which are publicly available, and learns of essential patent claims as the patents issue—such as the Asserted Patents in this case.

33. Defendant also knew of the Asserted Patents at least by June 20, 2021, when Atlas specifically notified Defendant of the Newracom Wi-Fi 6 patent portfolio. More specifically, on that date, Atlas sent Vantiva’s predecessor, Technicolor, letters via its EVP Group General Counsel, Irène Cambourakis, and President of Connect Home, Luis Martinez Amago, presenting Defendant “with an opportunity for Technicolor to license Standard Essential Patents (SEP) in Wi-Fi 6—the latest generation of Wi-Fi technology.” Exs. A-B. Further, Atlas informed Defendant

that the Asserted Patents “cover[] key improvements in Wi-Fi technology developed by Newracom’s internal R&D team and adopted in the 802.11ax Wi-Fi standard.” *Id.* In those initial June 20, 2021 letters, Atlas specifically invited Defendant to license the Asserted Patents. *Id.* Defendant acknowledged receipt of those licensing letters on June 28, 2021. Further, those letters reference Atlas’s website that explicitly identifies each of the Asserted Patents by patent number. *Id.*; <https://atlasglobaltechnologies.com/us-issued-patent/> (last visited Feb. 29, 2024).

34. Defendant also knew of the Asserted Patents and its infringement by at least June 29, 2021, when Mr. Craig Yudell conferred with Defendant’s representative Thomas Bohan via email in relation to Atlas’s Wi-Fi 6 portfolio. Ex. C. In that correspondence, Atlas offered Defendant to become “very early licensee to [Atlas’s] SEP portfolio.” *Id.* Atlas told Defendant that the portfolio included “129 patents” and listed them. Atlas further explained that the Newracom Wi-Fi 6 patents covered, for example, Defendant’s products that implemented Wi-Fi 6 capabilities. *Id.* Mr. Yudell also listed Atlas’s SEP patent portfolio by patent family. *Id.*

35. Defendant also knew about the Asserted Patents as part of its business competitive intelligence. In the course of its business and on information and belief, Defendant monitors the activities of competitors like Samsung, ASUSTeK, Sercomm, TP-Link, OnePlus, Zyxel, D-Link, Acer, Arcadyan, Dell, and HP. As part of those monitoring activities, Defendant learned that Atlas had brought lawsuits involving the Asserted Patents against each of Samsung, ASUSTeK, Sercomm, TP-Link, OnePlus, Zyxel, D-Link, Acer, Arcadyan, Dell, and HP. Thus, Defendant also learned of the Asserted Patents around the time the complaints were filed against each of those competitors: (1) Samsung (August 9, 2021); (2) ASUSTeK (August 9, 2021); (3) Sercomm (August 9, 2021); (4) TP-Link (November 22, 2021); (5) OnePlus (November 22, 2021); (6) Zyxel (April 4, 2022); (7) D-Link (April 4, 2022); (8) Acer (July 13, 2022); (9) Arcadyan (September 7, 2022); (10) Dell (May 12, 2023); and (11) HP (May 12, 2023).

36. In addition and at latest, Defendant was aware of the Asserted Patents as of the date of filing of this Complaint.

DEFENDANT’S USE OF THE PATENTED TECHNOLOGY

37. On information and belief, Defendant makes, uses, sells, and/or offers to sell in the United States, and/or imports into the United States various devices with Wi-Fi 6 capabilities. For example, Defendant makes, uses, and sells Access Points (“APs”) and Stations (“STAs”) that support Wi-Fi 6. Defendant’s devices with Wi-Fi 6 capability include software and hardware on the devices that implement the inventions claimed in the Asserted Patents; the portions of the Wi-Fi 6 standard covered by the Asserted Patents are mandatory, and practicing those portions of the Wi-Fi 6 standard will necessarily infringe the claims of the Asserted Patents. Defendant even advertises that certain of its products are Wi-Fi Certified 6 by the Wi-Fi Alliance. *See, e.g.*, <https://www.vantiva.com/resources/technicolor-connected-home-receives-wi-fi-6e-cpe-device-certification-for-the-nsp-market/> (last visited Jan. 31, 2024).

38. The Accused Products include all Defendant’s products that comply with the 802.11ax-2021 Standard, including but not limited to the following products: Cobra X2 – xDSL/XGS-PON Wi-Fi 6E gateway; Cobra Xh – DSL + LTE Wi-Fi 6E gateway; Cobra M – xDSL Wi-Fi 6 gateway; Eagle L Wi-Fi Extender; Eagle M Wi-Fi Extender; Eagle X Wi-Fi Extender; Eagle Xe Wi-Fi Extender; Eagle X2 – Wi-Fi Extender; Falcon 5G; 5G FWA Indoor CPE – COBRA 5G XTREAM; 5G FWA Indoor CPE – COBRA 5G; Gazelle – Fiber Gateway; Gazelle L2 – Fiber Gateway; Gazelle L3 – Fiber Gateway; Gazelle M; Gazelle S2; Gazelle S – Fiber Gateway; Gazelle X – Fiber Gateway; Jade; Marlin X – DOCSIS 3.1 Business Gateway; Marlin L – DOCSIS 3.1 gateway; and Marlin L2 – DOCSIS 3.1 Business Gateway. For the purpose of clarity, it is the intent of Atlas to accuse of infringement all Defendant’s Wi-Fi 6 products that are marketed or sold into the United States market.

39. Examples of Defendant’s Wi-Fi 6 products are shown below:

EAGLE Xe, Wi-Fi extender

- Wi-Fi 6E Tri-band 2.4GHz(2x2)
- 5GHz (2x2), 6GHz (4x4)
- EasyMesh R2
- Plume support



<https://www.vantiva.com/solutions/wi-fi-extenders/> (last visited Jan. 31, 2024).

Gazelle X - Fiber Gateway

- 10G
- Wi-Fi 6 dual-band 2.4GHz 4x4)
- 5GHz (4x4)



<https://www.vantiva.com/solutions/fiber-gateways/> (last visited Jan. 31, 2024).

Jade set-top box

- Wi-Fi 6 – dual band 2x2 IEEE 802.11ax 5 GHz and 2x2 IEEE 802.11ax 2.4 GHz Wi-Fi



<https://www.vantiva.com/solutions/jade-set-top-box/> (last visited Jan. 31, 2024).

40. On January 9, 2024, Vantiva acquired CommScope Home Networks. Any new Wi-Fi 6 products of this acquired division developed subsequent to the January 9, 2024, acquisition also form part of the Accused Products in this case.

41. Vantiva's Accused Products use Wi-Fi 6 chips. For example, some of Vantiva's Accused Products use the Broadcom BCM6756 Wi-Fi 6 chip, which according to Broadcom supports "uplink and downlink OFDMA [that] increases wifi capacity in congested environments" and has "full compliance with IEEE and Wi-Fi Alliance (WFA) Wi-Fi 6/6E specifications." <https://fcc.report/FCC-ID/G95OWA7111/6702306> (last visited Feb. 29, 2024); <https://www.broadcom.com/products/wireless/wireless-lan-infrastructure/bcm6756> (last visited Feb. 29, 2024).

42. On information and belief, Defendant uses the Accused Products in an infringing manner in the United States, both alone and jointly with its customers. For example, and on information and belief, Defendant's employees use the Accused Products to perform the infringing methods in the United States at Defendant's U.S. offices (which use Defendant's Wi-Fi 6 products to connect to and provide a wireless network) when sending and receiving data over Defendant's wireless networks.

43. On information and belief, Defendant's employees also use the Accused Products to perform the infringing methods in the United States when they demonstrate the infringing Wi-Fi 6 features of the Accused Products to actual and potential U.S. customers, for example at trade shows, product demonstrations, and more generally as part of selling the Accused Products. For example, Defendant's employees use the Accused Products when demonstrating their functionality to customers at trade shows. Defendant's employees regularly attend trade shows in the United States, including the CES shows in Las Vegas and other shows in Denver and Orlando. <https://www.vantiva.com/events/> (last visited Feb. 29, 2024); <https://www.vantiva.com/resources/lets-meet-at-ces-las-vegas-5-8th-january-2023/> (last visited Feb. 29, 2024); <https://www.vantiva.com/events/vantiva-at-florida-self-storage-association-2024/> (last visited Feb. 29, 2024); <https://www.vantiva.com/events/vantiva-at-ssa-fall-conference-tradeshaw/> (last visited Feb. 29, 2024); <https://www.vantiva.com/events/scte-cable-tec-expo-2023/> (last visited Feb. 29, 2024). Vantiva plans to continue sending its employees to trade shows

in the United States. <https://www.vantiva.com/events/> (previewing events in Maryland and Las Vegas in the first half of 2024)_(last visited Feb. 29, 2024).

44. On information and belief, Defendant’s employees also use the Accused Products to perform the infringing methods in the United States when designing, developing, and testing the Accused Products and their Wi-Fi 6 functionalities.

45. On information and belief, Defendant’s employees also use the Accused Products to perform the infringing methods in the United States as part of providing customer support to Defendant’s actual and potential customers, for example when trouble-shooting customer issues and resolving technical problems. For example, Defendant tells its customers to “Contact Vantiva to see how we can help your customers experience these world-class Wi-Fi 6 offerings.” <https://www.youtube.com/watch?v=wcWFuJEJtcI> at 2:20 (last visited Feb. 29, 2024). Further, Vantiva has a Wi-Fi 6 test house in Lawrenceville, GA that Vantiva “specifically setup for network testing.” <https://youtu.be/UeWr8PxZa-w> (last visited Feb. 29, 2024).

FIRST COUNT

(Infringement of U.S. Patent No. 9,531,520)

46. Atlas incorporates by reference the allegations set forth in Paragraphs 1-45 of this Complaint as though fully set forth herein.

47. The ’520 Patent, entitled “Apparatus and Method for Downlink and Uplink Multi-User Transmissions,” was duly and lawfully issued on December 27, 2016. Atlas is the owner of all right, title, and interest in the ’520 Patent. The ’520 Patent was filed on March 23, 2016 as Application No. 15/078,920 and claims the benefit of U.S. Provisional Application No. 62/140,349, filed on March 30, 2015, and U.S. Provisional Application No. 62/137,138, filed on March 23, 2015. See <https://patentimages.storage.googleapis.com/6e/2c/4f/d2594a2dd4685e/US9531520.pdf>.

48. The ’520 Patent is directed to important improvements related to triggering frames for scheduling multi-user uplink acknowledgements that were first introduced in 802.11ax. Newracom was a key contributor to the concepts and implementation details of triggering frames and uplink

multi-user acknowledgements. Certain claims (*e.g.*, '520 claim 1) recite a method directed to a transmitting AP device, in which the AP transmits a downlink multi-user frame to multiple STA devices that includes information in the MAC Protocol Data Unit (MPDU) of the downlink frame which solicits an uplink acknowledgement from the STA as part of a multi-user acknowledgement frame. The Accused AP Products are configured and designed to transmit the aforementioned trigger frame and receive the aforementioned uplink multi-user acknowledgments, and they do in fact transmit and receive those frames during normal use as intended by Defendant. Other claims (*e.g.*, '520 claim 8) recite a method directed to a STA device, in which the STA receives and processes a downlink multi-user frame includes information in the MAC Protocol Data Unit (MPDU) of the downlink frame which solicits an uplink acknowledgement from the STA as part of a multi-user acknowledgement frame. The Accused STA Products are configured and designed to receive and process the aforementioned trigger frame and transmit the aforementioned uplink multi-user acknowledgments, and they do in fact transmit and receive those frames during normal use as intended by Defendant.

49. Defendant directly infringes the method claims of the '520 Patent under 35 U.S.C. § 271(a) by using the Accused Products in the United States as described in paragraphs 37-45 above. Users of the Accused Products infringe at least claims 1 and 8 of the '520 Patent when using those Accused AP Products to practice the 802.11ax Standard, as indicated in Defendant's marketing materials for the Accused Products. The Accused Products operate as AP devices that are designed by Defendant and operate consistent with the requirements of 802.11ax. This includes the claimed ability to generate and transmit a trigger frame to multiple STAs and then simultaneously receive multi-user acknowledgment transmission from those STAs. *See e.g.*, 802.11ax-2021 § 4.3.15a (High efficiency (HE) STA); § 9.2.3 (General Frame Format); § 9.2.4.6.1 (HT Control Field); § 9.2.4.6.3a (HE variant); § 9.2.4.6a.1 (TRS Control); § 26.5.2.3.4 (TXVECTOR parameters for HE TB PPDU response to TRS Control subfield); Figure 9-2 (MAC frame format); Figures 9-19a and 9-19b; Figure 9-22a; Figure 10-14a; and Figure 27-11. Similarly, the Accused STA Products operate as STA devices that are designed by Defendant and operate consistent with the

requirements of 802.11ax. This includes the claimed ability to receive and process a trigger frame and then transmit multi-user acknowledgments. *See e.g., id.*

50. For example, Figure 10-14a from the Wi-Fi 6 Standard shows the downlink multi-user frame (referred to as an “HE MU PPDU”) that an AP, such as one of Defendant’s Accused AP Products, generates and transmits to a plurality of STA devices, as well as the multi-user acknowledgment transmission (referred to as “OFDMA BA”) that the AP receives from the STA devices.

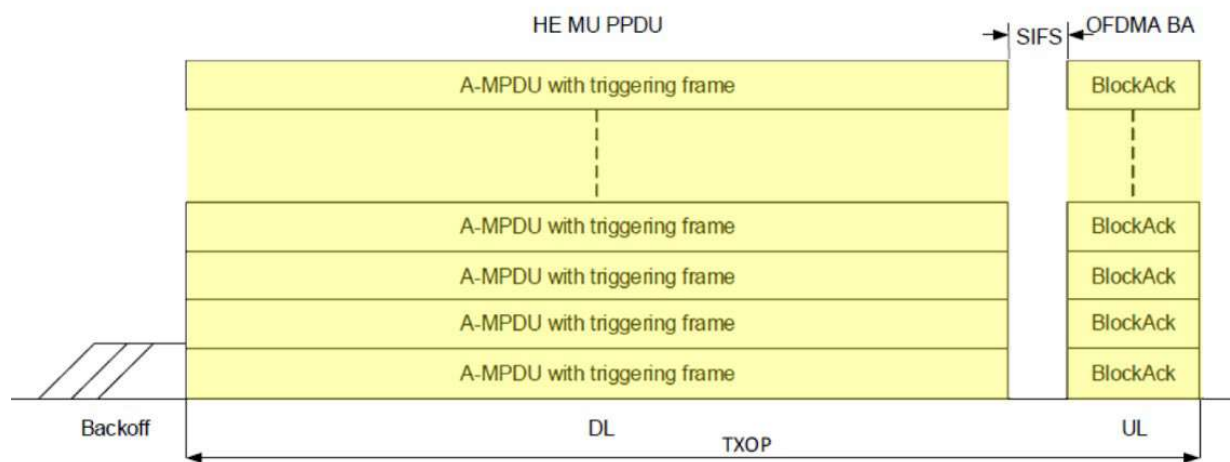
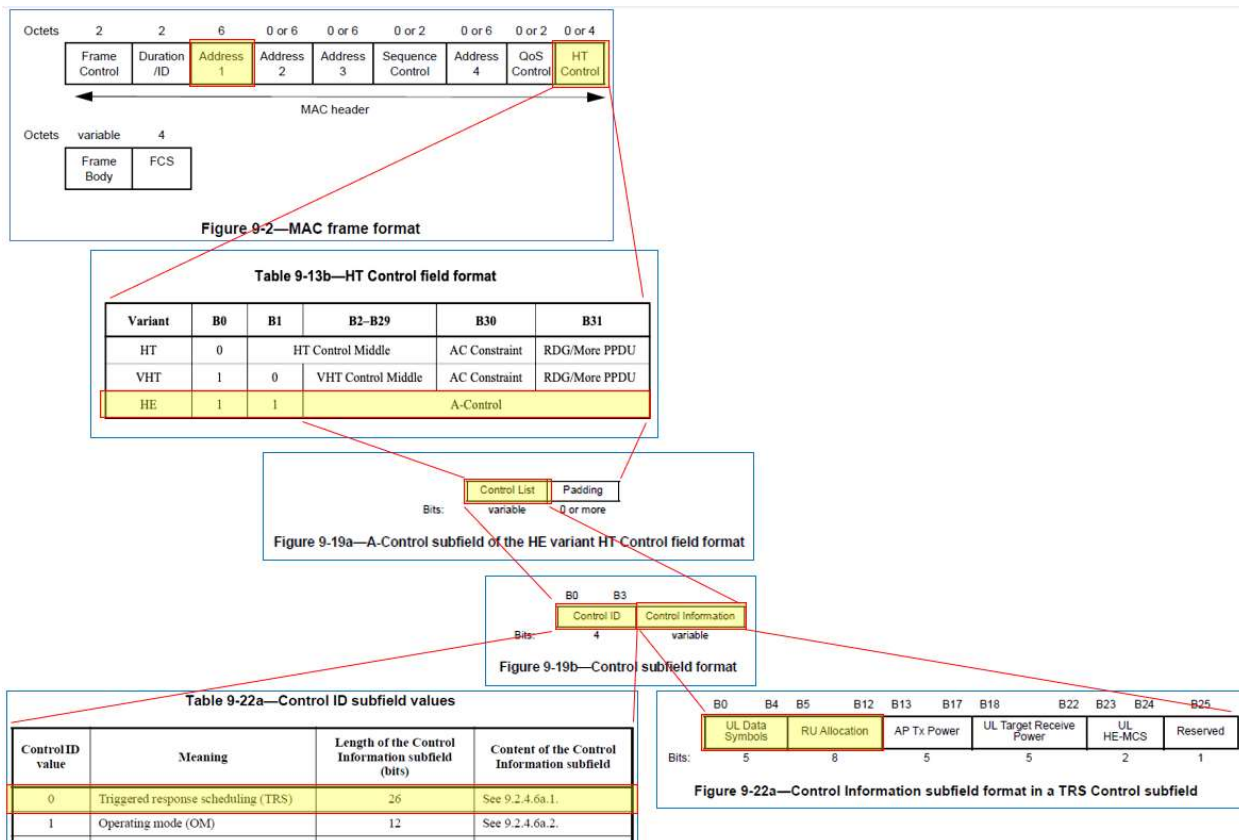

Figure 10-14a—Example of HE MU PPDU transmission with immediate UL OFDMA acknowledgment

51. Further, the following annotated and amalgamated figures from the Wi-Fi 6 Standard show the MAC contents of the downlink multi-user frame that Defendant’s Accused AP Products generates and transmits during normal and intended operation. As shown in Figure 9-2, the MAC frame contains a destination address (referred to as “Address 1”) that identifies the intended receiver(s) of the frame. Further, the MAC frame contains an HT Control field, the possible contents of which are shown in Table 9-13b. If bits B0 and B1 of the HT Control field are “11,” that indicates the HT Control field has been extended to accommodate the 802.11ax standard using the HE variant, and the A-Control subfield will be present. The A-Control subfield has a Control List subfield shown in Figure 9-19a, which in turn has Control ID and Control Information subfields shown in Figure 9-19b. The Control ID subfield may have a value of “0,” which (as

shown in Table 9-22a) indicates that the Control Information subfield provides a triggering frame. And when a triggering frame is used, the Control Information subfield has UL Data Symbols and RU Allocation subfields (as shown in Figure 9-22a), which are acknowledgment information that indicates properties for the uplink acknowledgment responsive transmission (e.g., the number of OFDM data symbols and resource unit allocation for that uplink acknowledgment responsive transmission).



52. In addition to the situation described in the preceding paragraph, Defendant’s Accused AP Products also transmit trigger frames (such as MU-BAR Trigger frames) carried in A-MPDUs of the DL MU PDU and receive an MU acknowledgement. This scenario also infringes the ’520 claims. An AP transmits MAC frames as part of a downlink transmission using frame formats described in 802.11ax-2021. Each MAC frame contains a header, a body, and a frame check sequence. MAC frame formats are described in §9 of the Wi-Fi 6 Standard. 802.11ax-2021 at §9

Frame Formats. The contents of the Trigger frame are shown in Figure 9-64a of the Wi-Fi 6 Standard:

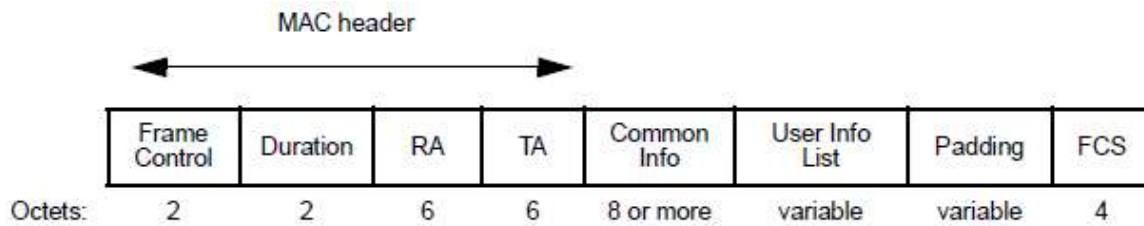

Figure 9-64a—Trigger frame format

53. A Trigger frame contains a Common Info field and a User Info List field with User Info fields, per Figure 9-64b and 9-64d. The Common Info field and the User Info List field carry scheduling information for a Station to use for generating a response. *See* 802.11ax-2021 at § 9.3.1.22; *id.* at § 27.3.2.6; *id.* at § 26.4.4.4. An HE TB PPDU is generated by an HE STA in response to a triggering frame from an AP. *See* 802.11ax-2021 at § 27.3.4 HE PPDU Formats; *id.* at § 27.1.4 PPDU Formats. The QoS Control field of the MAC header contains the Ack Policy Indicator subfield (at bits 5-6). 802.11ax-2021 at § 9.2.4.5.1. If the ACK Policy Indicator of a MU PPDU is “01” indicating HETP Ack, then the STA will immediately acknowledge reception in multi-user format by use of an HE TB PPDU. 802.11ax-2021 at § 9.2.4.5.4; *id.* at § 10.3.2.13.2. Figure 10-14a shows the downlink multi-user triggering frame (referred to as an “HE MU PPDU”) that an AP generates and transmits to a plurality of STA devices, as well as the multi-user acknowledgment transmission (referred to as “OFDMA BA”) that the AP receives from the STA devices:

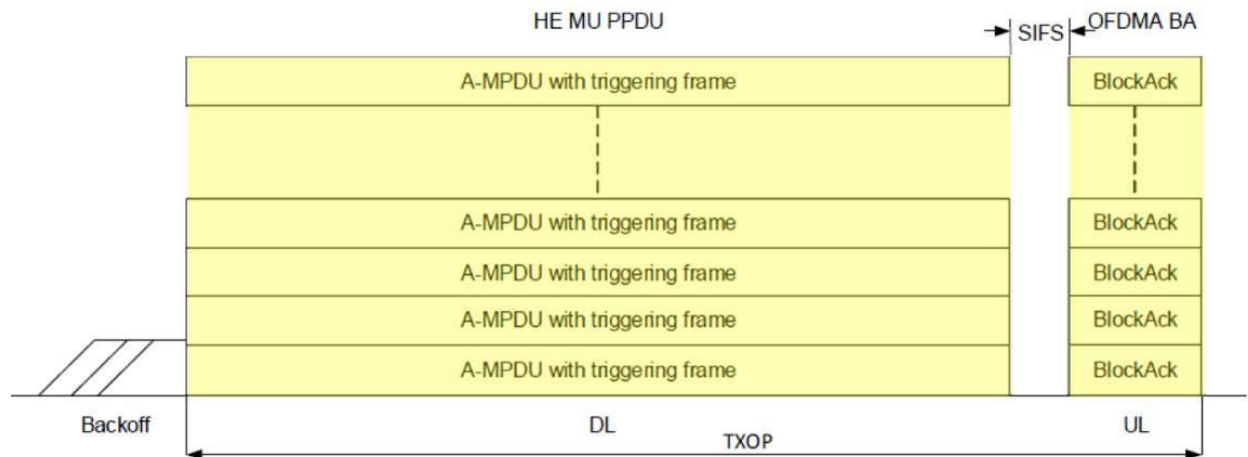

Figure 10-14a—Example of HE MU PPDU transmission with immediate UL OFDMA acknowledgment

Per Figure 10-14a, a triggering frame (such as an MU-BAR trigger frame) may be embedded in one or more A-MPDUs of the DL MU frame and solicit an acknowledgement:

A non-AP STA that is the recipient, within an HE MU PPDU, of a QoS Data frame or QoS Null frame with HETP Ack ack policy, of an MU-BAR Trigger frame or a GCR MU-BAR Trigger frame, or of a Management frame that solicits acknowledgment, shall send the immediate response according to the scheduling information that is carried either in the Trigger frame(s) or TRS Control subfield. ... An AP may use an MU-BAR Trigger frame or a GCR MU-BAR Trigger frame to solicit acknowledgment frames from multiple HE STAs to which the AP has sent QoS Data frames with Block Ack ack policy or from which the AP has not received immediate acknowledgment frames after sending QoS Data frames with HETP Ack ack policy in an HE MU PPDU.

802.11ax-2021 at § 10.3.2.13.2. Each RU of the plurality of RUs in the downlink multi-user frame is addressed to a respective station in the plurality of stations. *See* 802.11ax-2021 § 27.3.11.8.1; *id.* at § 26.11.1. Each RU in the DL MU frame includes a respective A-MPDU with a triggering frame, such as an MU-BAR trigger frame, as shown for example in Figure 10-14a.

54. In addition to directly infringing the '520 Patent's method claims, Defendant also indirectly infringes the '520 Patent claims. Where acts constituting direct infringement of the '520 Patent are not performed by Defendant, such acts constituting direct infringement of the '520 Patent are performed by Defendant's customers or end-users (the direct infringers) who act at the direction

and/or control of Defendant, with Defendant's knowledge. Upon information and belief, Defendant intends to cause, and has taken affirmative steps to induce, infringement by importers, online stores, distribution partners, retailers, reseller partners, solution partners, consumers, end users, and other related service providers by at least, *inter alia*, creating advertisements that promote the infringing use of the Accused Products, creating and/or maintaining established distribution channels for the Accused Products into and within the United States, manufacturing the Accused Products in conformity with U.S. laws and regulations, distributing or making available instructions or manuals for these products to purchasers and prospective buyers, testing wireless networking features in the Accused Products, and/or providing technical support, replacement parts, or services for these products to purchasers in the United States.

55. Atlas is informed and believes, and on that basis alleges, that Defendant indirectly infringes at least claims 1 and 8 of the '520 Patent by active inducement in violation of 35 U.S.C. § 271(b), by at least manufacturing, supplying, distributing, selling, and/or offering for sale the Accused Products to their customers with the knowledge and intent that their further making, using, selling, offering to sell, or importing those products would constitute direct infringement of the '520 Patent.

56. For example, Defendant advertises to its customers that it sells products that comply with the 802.11ax Standard. See <https://www.vantiva.com/solutions/fiber-gateways/> (last visited Jan. 31, 2024). Defendant also instructs its customers on how to connect the Accused Products to Wi-Fi networks so that they may practice the 802.11ax Standard. Once the Accused Products are installed, they will automatically implement the 802.11ax Standard in an infringing manner based upon the hardware and software provided in the Accused Products. Defendant also provides technical support to its customers and end users and encourages them to use the Accused Products in an infringing manner. Thus, with full knowledge of the '520 Patent as described in paragraphs 32-36 above, Defendant induced its customers and end users to directly infringe the '520 Patent by using the Accused Products to perform the infringing methods.

57. Defendant's acts of infringement have caused damage to Atlas, and Atlas is entitled to recover from Defendant (or any successor entity to Defendant) the damages sustained by Atlas as a result of Defendant's wrongful acts in an amount subject to proof at trial.

SECOND COUNT

(Infringement of U.S. Patent No. 9,628,310)

58. Atlas incorporates by reference the allegations set forth in Paragraphs 1-57 of this Complaint as though fully set forth herein.

59. The '310 Patent, entitled "Long Training Field Sequence Construction," was duly and lawfully issued on April 18, 2017. Atlas is the owner of all right, title, and interest in the '310 Patent. The '310 Patent was filed on March 23, 2016 as Application No. 15/079,007 and claims the benefit of U.S. Provisional Application No. 62/138,302, filed on March 25, 2015, U.S. Provisional Application No. 62/157,849, filed on May 6, 2015, U.S. Provisional Application No. 62/214,139, filed on Sep. 3, 2015, U.S. Provisional Application No. 62/214,156, filed on Sep. 3, 2015, U.S. Provisional Application No. 62/236,815, filed on Oct. 2, 2015, U.S. Provisional Application No. 62/250,944, filed on Nov. 4, 2015, and U.S. Provisional Application No. 62/264,812, filed on Dec. 8, 2015. *See* <https://patentimages.storage.googleapis.com/3d/dc/79/835b3a944781ec/US9628310.pdf>.

60. The '310 Patent relates to generating a long training field sequence in 802.11ax. In 802.11ax, an HE frame is associated with one of the channel bandwidths, either 20 MHz, 40 MHz, 80 MHz, 160 MHz, or 80+80 MHz (where the 80 MHz channels are not contiguous). The Accused STA Products are designed and configured to receive an HE-LTF symbol and obtain an HE-LTF sequence corresponding to the channel bandwidth and HE-LTF mode. Similarly, the Accused AP Products are designed and configured to transmit an HE-LTF symbol by using an HE-LTF sequence corresponding to the channel bandwidth and HE-LTF mode. In both cases, the HE-LTF mode of the HE-LTF symbol can be one of a plurality of HE-LTF modes, including a 4xHE-LTF mode, a 2xHE-LTF mode, and a 1xHE-LTF mode.

61. Defendant directly infringes the '310 Patent under 35 U.S.C. § 271(a) by making, using, selling, and/or offering to sell in the United States, and/or importing into the United States products that directly infringe the '310 Patent, including the above identified Accused Products. The Accused Products infringe at least claims 1 and 15 of the '310 Patent by practicing the 802.11ax Standard, as indicated in Defendant's marketing material for the Accused Products. The Accused Products operate as Access Point devices or Station devices that are designed by Defendant and operate consistent with the requirements of 802.11ax. For the Accused Products, this includes the claimed ability to determine a channel bandwidth, determine an HE-LTF mode, generate an HE-LTF symbol by using an HE-LTF sequence corresponding to a determined channel bandwidth and HE-LTF mode, and transmit an HE-PPDU including that HE-LTF symbol. *See, e.g.*, 802.11ax-2021 § 4.3.15a (channel bandwidths); § 27.3.11.10 (HE-LTF modes); § 27.3.11.10 (plurality of HE-LTF sequences); § 27.3.4 (HE PPDU structure).

62. The Accused Products have one or more memories, and one or more processors coupled to said memories, the processor configured to cause the Accused Product to possess the claimed capabilities, *e.g.*, as described below.

63. The Accused Products determine a channel bandwidth among a plurality of bandwidths including a 20 MHz channel bandwidth, 40 MHz channel bandwidth, and 80 MHz channel bandwidth. For example, HE STA devices (including both AP devices and non-AP devices) can support operation in 20 MHz, 40 MHz, and 80 MHz operating channels. 802.11ax-2021 § 4.3.15a. (“Support for 20 MHz operating channel width is mandatory in an HE STA ... Support for 40 MHz and 80 MHz operating channel width is mandatory in an HE STA that is not a 20 MHz-only non-AP HE STA”).

64. The Accused Products determine a high efficiency long training field (HE-LTF) mode among a plurality of HE-LTF modes including a 4x HE-LTF mode and a 2x HE-LTF mode. For example, in 802.11ax, an HE PPDU includes an HE-LTF field that provides a means for a receiver to estimate a channel. “An HE PPDU supports 3 HE-LTF types: 1x HE-LTF, 2x HE-LTF, and

4x HE-LTF.” 802.11ax-2021 § 27.3.11.10. Table 27-31 defines the HE-LTF and GI duration combinations for various HE PDU formats:

HE-LTF type and GI duration combination	HE SU PDU	HE MU PDU	HE ER SU PDU	HE TB PDU	HE sounding NDP	HE TB feedback NDP
1x HE-LTF 0.8 μ s GI	O	N/A	O	N/A	N/A	N/A
1x HE-LTF 1.6 μ s GI	N/A	N/A	N/A	CM3	N/A	N/A
2x HE-LTF 0.8 μ s GI	M	M	M	N/A	M	N/A
2x HE-LTF 1.6 μ s GI	M	M	M	M	M	N/A
4x HE-LTF 0.8 μ s GI	CM1	CM2	O	N/A	N/A	N/A
4x HE-LTF 3.2 μ s GI	M	M	M	M	O	M

Legend
M = mandatory.
CM1 = Mandatory if the STA supports 4x HE-LTF 0.8 μ s GI for HE ER SU PDU. Otherwise, optional.
CM2 = For an AP, mandatory for transmission if the AP supports 4x HE-LTF 0.8 μ s GI for HE ER SU PDU. For a non-AP STA, mandatory for reception if the non-AP STA supports 4x HE-LTF 0.8 μ s GI for HE ER SU PDU. Otherwise, optional.
CM3 = Mandatory for full-bandwidth UL MU-MIMO if the STA supports UL MU-MIMO. Otherwise, not supported. N/A for partial-bandwidth UL MU-MIMO or UL OFDMA.
O = optional.
N/A = not supported by the PDU format.

If a STA does not support transmission or reception of a particular PDU format, then the M/CM/O designation is not applicable for the transmission or reception, respectively, of that PDU format.

802.11ax-2021 Table 27-31.

65. The Accused Products generate an HE-LTF symbol by using an HE-LTF sequence corresponding to the determined channel bandwidth and the determined HE-LTF mode, wherein the HE-LTF sequence is among a plurality of HE-LTF sequences for the plurality of bandwidths and the plurality of HE-LTF modes. When an Accused AP Product generates an HE PDU, it determines a bandwidth on which to transmit and an HE-LTF mode, as shown above. Based on this determination, a transmitting AP will generate an HE-LTF symbol by using an HE-LTF sequence corresponding to the determined bandwidth and HE-LTF mode. 802.11ax-2021 § 27.3.11.10. The chosen HE-LTF sequence is one of a plurality of different HE-LTF sequences, each of which corresponds to a particular bandwidth and HE-LTF mode. For example, when the determined channel bandwidth is 20 MHz and the determined HE-LTF mode is 2x HE-LTF, the HE-LTF sequence is specified by Equation (27-42):

In a 20 MHz transmission, the 2x HE-LTF sequence transmitted on subcarriers [-122: 122] is given by Equation (27-42).

$$\begin{aligned}
 &HELTF_{-122,122} = \\
 &\{-1, 0, -1, 0, -1, 0, +1, 0, +1, 0, -1, 0, +1, 0, -1, 0, -1, 0, -1, 0, -1, 0, +1, 0, -1, 0, +1, 0, \\
 &-1, 0, -1, 0, +1, 0, +1, 0, -1, 0, +1, 0, +1, 0, +1, 0, +1, 0, -1, 0, +1, 0, -1, 0, +1, 0, \\
 &-1, 0, -1, 0, +1, 0, +1, 0, -1, 0, +1, 0, -1, 0, -1, 0, -1, 0, +1, 0, -1, 0, +1, 0, +1, 0, \\
 &+1, 0, -1, 0, -1, 0, +1, 0, -1, 0, -1, 0, -1, 0, -1, 0, +1, 0, -1, 0, -1, 0, -1, 0, +1, 0, \\
 &+1, 0, +1, 0, -1, 0, -1, 0, +1, 0, 0, 0, +1, 0, -1, 0, +1, 0, +1, 0, -1, 0, +1, 0, +1, 0, -1, 0, \\
 &+1, 0, +1, 0, -1, 0, -1, 0, +1, 0, -1, 0, +1, 0, +1, 0, +1, 0, +1, 0, -1, 0, +1, 0, -1, 0, +1, 0, \\
 &+1, 0, -1, 0, -1, 0, +1, 0, -1, 0, -1, 0, -1, 0, -1, 0, +1, 0, -1, 0, +1, 0, +1, 0, -1, 0, \\
 &-1, 0, +1, 0, +1, 0, -1, 0, +1, 0, -1, 0, -1, 0, -1, 0, +1, 0, -1, 0, +1, 0, +1, 0, +1, 0, +1, 0, \\
 &-1, 0, -1, 0, +1, 0, -1, 0, -1, 0, -1, 0, -1, 0, -1, 0, +1, 0, -1, 0, +1, 0, +1, 0, +1, 0, +1, 0, \\
 &-1, 0, -1, 0, +1, 0, -1, 0, -1, 0, -1, 0, -1, 0, -1, 0, +1, 0, -1, 0, +1, 0, +1, 0, +1, 0, +1, 0\}
 \end{aligned}
 \tag{27-42}$$

A plurality of different HE-LTF sequences based on the various bandwidth and mode combinations are given in equations 27-41 through 27-52.

66. The Accused Products transmit a high efficiency physical layer protocol data unit (HE PPDU) including the HE-LTF symbol, in the determined channel bandwidth. For example, the HE PPDU is transmitted including an HE-LTF symbol using the appropriate HE-LTF sequence, as illustrated in Figures 27-8 through 27-11 (highlighting added):

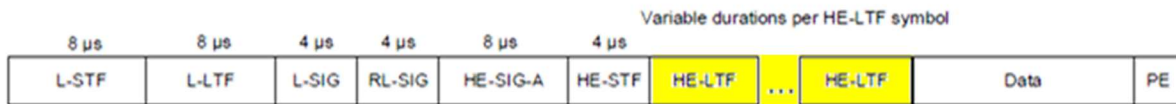

Figure 27-8—HE SU PPDU format

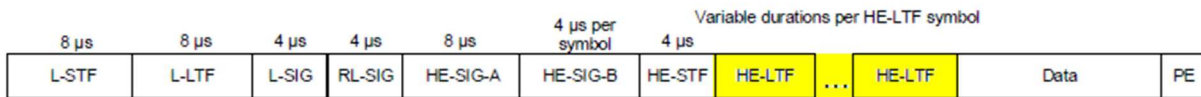

Figure 27-9—HE MU PPDU format

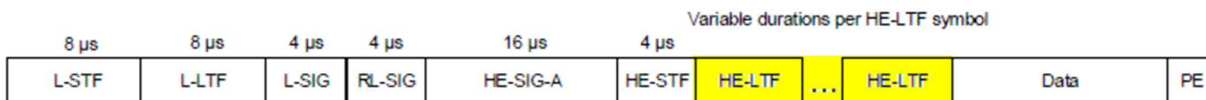
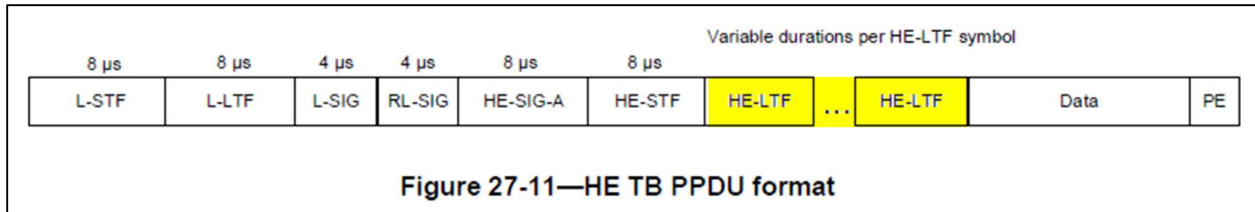

Figure 27-10—HE ER SU PPDU format



67. In the Accused Products, the plurality of HE-LTF sequences includes a first HE-LTF sequence for the 20 MHz channel bandwidth and the 4x HE-LTF mode (*see* 802.11ax equation 27-43), a second HE-LTF sequence for the 20 MHz channel bandwidth and the 2x HE-LTF mode (*see* equation 27-42), a third HE-LTF sequence for the 40 MHz channel bandwidth and the 4x HE-LTF mode (*see* equation 27-46), a fourth HE-LTF sequence for the 40 MHz channel bandwidth and the 2x HE-LTF mode (*see* equation 27-45), a fifth HE-LTF sequence for the 80 MHz channel bandwidth and the 4x HE-LTF mode (*see* equation 27-49), and a sixth HE-LTF sequence for the 80 MHz channel bandwidth and the 2x HE-LTF mode (*see* equation 27-48).

68. In addition to directly infringing the '310 apparatus claims by making, selling and using infringing products in the United States, Defendant also indirectly infringes the '310 Patent claims. Where acts constituting direct infringement of the '310 Patent are not performed by Defendant, such acts constituting direct infringement of the '310 Patent are performed by Defendant's customers or end-users who act at the direction and/or control of Defendant, with Defendant's knowledge.

69. Atlas is informed and believes, and on that basis alleges, that Defendant indirectly infringes at least claims 1 and 15 of the '310 Patent by active inducement in violation of 35 U.S.C. § 271(b), by at least manufacturing, supplying, distributing, selling, and/or offering for sale the Accused Products to their customers and end users of Defendant's Accused Products with the knowledge and intent that their further making, using, selling, offering to sell, or importing those products would constitute direct infringement of the '310 Patent.

70. For example, Defendant advertises to its customers that it sells products that comply with the 802.11ax Standard. *See, e.g.,* <https://www.vantiva.com/solutions/fiber-gateways/> (last visited Jan. 31, 2024). Defendant also instructs its customers on how to connect the Accused Products to

Wi-Fi networks so that they may practice the 802.11ax Standard. Once the Accused Products are installed, they will automatically implement the 802.11ax Standard in an infringing manner based upon the hardware and software provided in the Accused Products. Defendant also provides technical support to its customers and end users and encourages them to make, use, sell, offer to sell, and/or import the Accused Products in an infringing manner. Thus, with full knowledge of the '310 Patent as described in paragraphs 32-36 above, Defendant induced its customers and end users to directly infringe the '310 Patent by making, using, selling, offering to sell, and/or importing the Accused Products.

71. Defendant's acts of infringement have caused damage to Atlas, and Atlas is entitled to recover from Defendant (or any successor entity to Defendant) the damages sustained by Atlas as a result of Defendant's wrongful acts in an amount subject to proof at trial.

THIRD COUNT

(Infringement of U.S. Patent No. 9,641,234)

72. Atlas incorporates by reference the allegations set forth in Paragraphs 1-71 of this Complaint as though fully set forth herein.

73. The '234 Patent, entitled "Preamble and Payload for High Efficiency (HE) Transmission," was duly and lawfully issued on May 2, 2017. Atlas is the owner of all right, title, and interest in the '234 Patent. The '234 Patent was filed on April 22, 2016 as Application No. 15/136,830 and claims the benefit of U.S. Provisional Application No. 62/152,509, filed on April 24, 2015.

74. The '234 Patent relates to generating and receiving a trigger frame. A trigger frame comprises both an L-SIG and an HE-SIG-A field. The HE-SIG-A field in the trigger frame comprises a transmission opportunity duration remaining after the transmission of the trigger frame. In response to transmitting a trigger frame, a device will receive an uplink frame comprising an L-SIG field and an HE-SIG-A field. The length of the received L-SIG and HE-SIG-A fields are based on the trigger frame. The duration field of the HE-SIG-A field in the uplink transmission is derived from the duration field in the downlink trigger frame.

75. Defendant directly infringes the '234 Patent under 35 U.S.C. § 271(a) by making, using, selling, and/or offering to sell in the United States, and/or importing into the United States products that directly infringe the '234 Patent, including the above identified Accused Products. The Accused Products infringe at least claim 1 of the '234 Patent by practicing the 802.11ax Standard, as indicated in Defendant's marketing material for the Accused Products. The Accused Products operate as Access Point devices that are designed by Defendant and operate consistent with the requirements of 802.11ax.

76. The Accused Products comprise one or more memories, and one or more processors coupled to said memories, the processor(s) configured to cause the Accused Products to possess the claimed capabilities, *e.g.*, as described below.

77. The Accused Products comprise generating a trigger frame, the trigger frame comprising a first content and a second content. The 802.11ax Standard discloses the format of a trigger frame. The UL Length field comprises the first content.

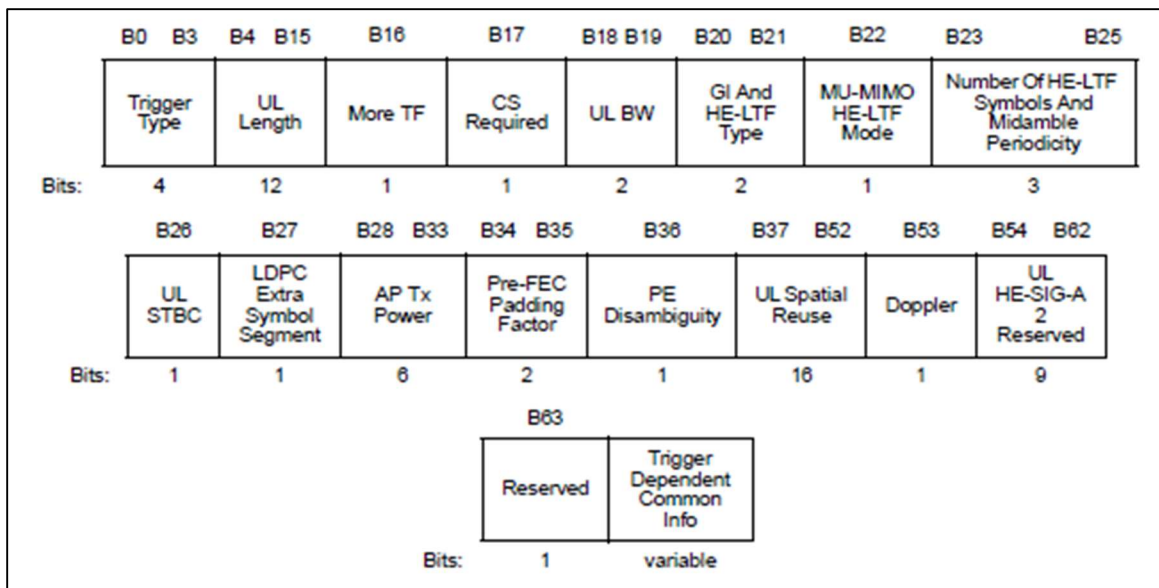

802.11ax-2021 § 9.3.1.22.1.

78. The Duration/ID field of the MAC header comprises the second content.

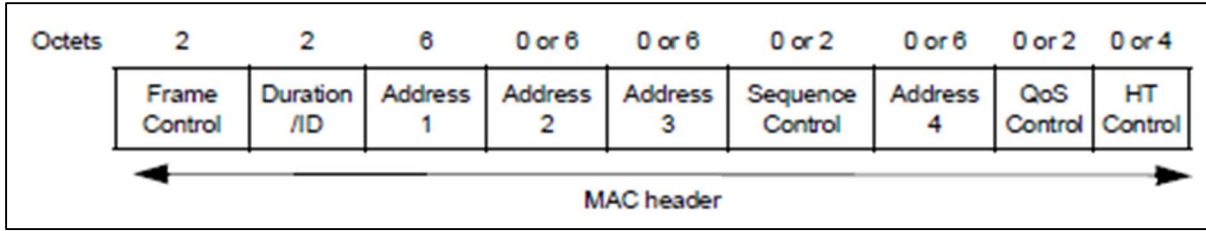

802.11-2020 § 9.2.3.

79. The Accused Products comprise that the first content is associated with a legacy signal (L-SIG) field of an uplink frame. The 802.11ax Standard explains that “the UL Length subfield of the Common Info Field indicates the value of the L-SIG LENGTH field of the solicited HE TB PDU.” 802.11ax-2021 § 9.3.1.22.1.

80. The Accused Products comprise that the second content is associated with a high efficiency signal-A (HE-SIG-A) field of the uplink frame. As explained above, the Duration/ID field in the MAC header comprises the second content. The uplink frame can be an HE TB feedback NDP or an HE TB PDU. The Duration field is associated with the HE-SIG-A field of the uplink frame because it is used to calculate the potential duration information. *See* 802.11ax-2021 § 26.11.5.

81. The Accused Products comprise providing the trigger frame for transmission. As explained above, the 802.11ax Standard discloses the format of a trigger frame transmitted by an Access Point to a Station. 802.11ax-2021 § 9.3.1.22.1.

82. The Accused Products comprise receiving the uplink frame in response to the trigger frame, the uplink frame comprising the L-SIG field and the HE-SIG-A field. According to the 802.11ax Standard, an Access Point can receive an HE TB PDU in response to transmitting a trigger frame. The Standard explains that “this format is used for a transmission that is a response to a triggering frame from an AP.” 802.11ax-2021 § 27.3.4. An HE TB PDU comprises an L-SIG field and an HE-SIG-A field.

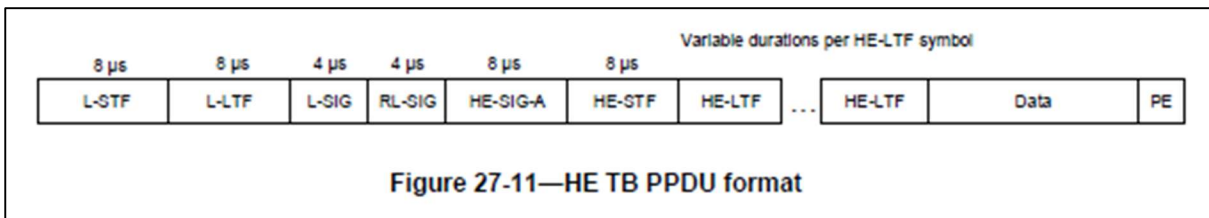

802.11ax-2021 § 27.3.4.

83. The Accused Products comprise wherein a length in the L-SIG field of the uplink frame is based on the trigger frame. The 802.11ax Standard explains that “the UL Length subfield of the Common Info Field [in a trigger frame] indicates the value of the L-SIG LENGTH field of the solicited HE TB PPDU.” 802.11ax-2021 § 9.3.1.22.1.

84. The Accused Products comprise wherein a duration in the HE-SIG-A field of the uplink frame is based on the trigger frame. The Duration field of the trigger frame is used to calculate the potential duration information of the HE-SIG-A field in the uplink frame. *See* 802.11ax-2021 § 26.11.5.

85. The Accused Products comprise providing the uplink frame for processing. In the 802.11ax Standard, an AP can receive either an HE TB feedback NDP or an HE TB PPDU. 802.11ax-2021 § 26.11.5.

86. The Accused Products comprise wherein the second content is a first transmission opportunity (TXOP) duration remaining after transmission of the trigger frame. As explained above, the second content is the Duration/ID field of the MAC header. The 802.11ax Standard explains that “in a MU-RTS Trigger frame, the Duration/ID field is set to the estimated time, in microseconds, required to transmit the pending frame(s), plus one CTS frame, plus the time to transmit the solicited HE TB PPDU if required, plus the time to transmit the acknowledgment for the solicited HE TB PPDU if required, plus applicable IFSs.” 802.11ax-2021 § 9.2.5.2. “In a MU-BAR Trigger frame, BSRP Trigger frame, GCR MU-BAR Trigger frame, BQRP Trigger frame, and NFRP Trigger frame, the Duration/ID field is set to the time required to transmit the solicited HE TB PPDU plus one SIFS.” 802.11ax-2021 § 9.2.5.2. “In a Basic Trigger frame, the Duration/ID field is set to the estimated time required to transmit the solicited HE TB PPDU, plus the estimated time required to transmit the acknowledgment for the solicited HE TB PPDU if required, plus applicable SIFs.” 802.11ax-2021 § 9.2.5.2. The 802.11ax Standard also explains that if “in any frame transmitted by a STA that is not the TXOP holder and is not specified by 9.2.5.1 to 9.2.5.7, the Duration/ID field is set to the value obtained from the Duration/ID field of

the frame that elicited the response minus the time, in microseconds, between the end of the PPDU carrying the frame that elicited the response and the end of the PPDU carrying the frame.”
802.11ax-2021 § 9.2.5.8.

87. The Accused Products comprise wherein the duration is a second TXOP duration remaining after transmission of the uplink frame, wherein the second TXOP duration is derived from the first TXOP duration. The claimed “duration” refers to the TXOP duration in the HE-SIG-A field of an uplink frame to the Access Point.

B0-B6	TXOP	7	<p>Set to 127 to indicate no duration information.</p> <p>Set to a value less than 127 to indicate the closest minimum bound on the duration information for NAV setting and protection of the TXOP as follows:</p> <p>If B0 is 0, the TXOP duration indicated is B1-B6, in units of 8 μs.</p> <p>If B0 is 1, the TXOP duration indicated is B1-B6, in units of 128 μs, plus 512 μs.</p> <p>See TXVECTOR parameter TXOP_DURATION.</p>
-------	------	---	--

802.11ax-2021 at Table 27-21. The 802.11ax Standard explains that the TXOP_DURATION is based on the Duration field in the MAC header of the trigger frame. TXOP_DURATION is “equal to the duration information indicated by the Duration field of the frame that solicits the response minus the time, in microseconds, between the end of the PPDU carrying the frame that solicited the HE TB PPDU and the end of the HE TB PPDU... If the calculated potential duration information is smaller than 8448 μ s, the TXVECTOR parameter TXOP_DURATION shall be set to the calculated potential duration information. Otherwise, the TXVECTOR parameter TXOP_DURATION shall be set to 8448.” 802.11ax-2021 § 26.11.5.

88. In addition to directly infringing the ’234 apparatus claims by making, selling and using infringing products in the United States, Defendant also indirectly infringes the ’234 Patent claims. Where acts constituting direct infringement of the ’234 Patent are not performed by Defendant, such acts constituting direct infringement of the ’234 Patent are performed by Defendant’s customers or end-users who act at the direction and/or control of Defendant, with Defendant’s knowledge.

89. Atlas is informed and believes, and on that basis alleges, that Defendant indirectly infringes at least claim 1 of the '234 Patent by active inducement in violation of 35 U.S.C. § 271(b), by at least manufacturing, supplying, distributing, selling, and/or offering for sale the Accused Products to their customers and end users of Defendant's Accused Products with the knowledge and intent that their further making, using, selling, offering to sell, or importing those products would constitute direct infringement of the '234 Patent.

90. For example, Defendant advertises to its customers that it sells products that comply with the 802.11ax Standard. *See, e.g.*, <https://www.vantiva.com/solutions/fiber-gateways/> (last visited Jan. 31, 2024). Defendant also instructs its customers on how to connect the Accused Products to Wi-Fi networks so that they may practice the 802.11ax Standard. Once the Accused Products are installed, they will automatically implement the 802.11ax Standard in an infringing manner based upon the hardware and software provided in the Accused Products. Defendant also provides technical support to its customers and end users and encourages them to make, use, sell, offer to sell, and/or import the Accused Products in an infringing manner. Thus, with full knowledge of the '234 Patent as described in paragraphs 32-36 above, Defendant induced its customers and end users to directly infringe the '234 Patent by making, using, selling, offering to sell, and/or importing the Accused Products.

91. Defendant's acts of infringement have caused damage to Atlas, and Atlas is entitled to recover from Defendant (or any successor entity to Defendant) the damages sustained by Atlas as a result of Defendant's wrongful acts in an amount subject to proof at trial.

FOURTH COUNT

(Infringement of U.S. Patent No. 9,832,058)

92. Atlas incorporates by reference the allegations set forth in Paragraphs 1-91 of this Complaint as though fully set forth herein.

93. The '058 Patent, entitled "Apparatus and Method for Scrambling Control Field Information for Wireless Communications," was duly and lawfully issued on November 28, 2017. Atlas is the owner of all right, title, and interest in the '058 Patent. The '058 Patent was filed on November 1,

2016 as Application No. 15/340,939, and claims the benefit of U.S. Provisional Application No. 62/250,373, filed on November 3, 2015, U.S. Provisional Application No. 62/294,248, filed on February 11, 2016, U.S. Provisional Application No. 62/294,269, filed on February 11, 2016, U.S. Provisional Application No. 62/294,968, filed on February 12, 2016, and U.S. Provisional Application No. 62/299,468, filed on February 24, 2016. See <https://patentimages.storage.googleapis.com/e3/bb/3a/4b73b3918fc71b/US9832058.pdf>.

94. The '058 Patent generally relates to improvements to 802.11ax, including enabling the HE-SIG-B field that includes important signaling information. “In some scenarios, repeated information in the SIG-B field may create repeated encoded bits of the SIG-B field, which may result in a transmission with an undesirably large peak-to-average power ratio (PAPR).” '058 Patent at 3:18-21. For example, “when long sequences of zeros happen to be confined within one or more HE-SIG-B OFDM symbols,” it will result in a “very large PAPR.” *Id.* at 3:21-24, 28-30. And “transmissions with a high PAPR may result in a reduction or a backoff of transmit power, which can lead to a loss in performance and coverage.” *Id.* at 3:30-32. To prevent high PAPR transmissions, the '058 Patent teaches to “scrambl[e] some or all of the HE-SIG-B field to rearrange any repeated information such as long strings of zeros.” *Id.* at 3:33-36. This “scrambling may be provided by performing a phase rotation.” *Id.* at 3:46-47. “For example, modulated symbols or data tones within a SIG-B field channel may be multiplied by a scrambling code (e.g., a phase rotation pattern such as a complex valued sequence) to produce scrambled symbols or data tones (e.g., phase rotated symbols or data tones).” *Id.* at 3:47-52. Importantly, the '058 Patent discloses a two-part phase rotation scrambling procedure: (1) “scrambling the information within [each 20 MHz] HE-SIG-B field channel” (*i.e.*, intra-channel phase rotation) and (2) “performing a phase rotation (sometimes referred to as a gamma rotation) of the entire HE-SIG-B field channels” (*i.e.*, inter-channel phase rotation amongst all the 20 MHz HE-SIG-B channels). *Id.* at 3:52-57. Such two-part phase-rotated scrambling “may help prevent a large PAPR transmission caused by repeated bits within the SIG-B field channel, thus improving communication performance and coverage.” *Id.* at 3:57-60.

95. Annotated Figure 23 discloses a preferred embodiment with multiple steps:

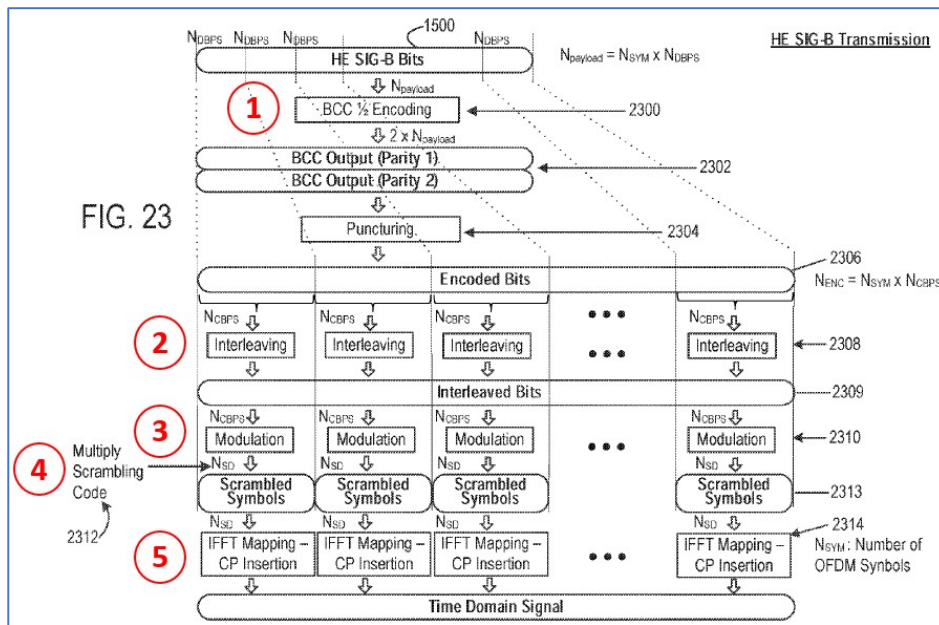

The HE-SIG-B Bits for one 20 MHz frequency band are [1] encoded at step 2300, [2] interleaved at step 2308, and [3] modulated at step 2310. '058 Patent at 25:67-26:32. The resulting data symbols are then [4] “multiplied by a scrambling code (*e.g.*, a 1st phase rotation pattern[.])” at step 2312. *Id.* at 26:35-40. An exemplary 1st phase rotation pattern may be “[1 0 0 0 0 1 0 1 0 1 1 1].” *Id.* at 23:2-3. This “1st phase rotation pattern can reduce PAPR of the HE-SIG-B field resulting from many identical or similar subfields or many zero values in the HE-SIG-B field within a 20 MHz channel.” *Id.* at 26:47-50. Next, the data symbols can be multiplied by a “2nd phase rotation pattern” that is unique to each 20 MHz frequency band, “referred to as a gamma rotation” (and not shown in Figure 23 above). *Id.* at 26:56-57. An exemplary 2nd phase rotation pattern may be “+1” for the lowest 20 MHz, “-1” for the second lowest 20 MHz, “-1” for the third lowest 20 MHz, and “+1” for the highest 20 MHz. *Id.* at 28:15-30. This “2nd phase rotation pattern can reduce the PAPR of the HE-SIG-B field resulting from many identical or similar subfields” in different 20 MHz frequency bands. *Id.* at 26:60-64. Finally, those resulting “[s]crambled (phase rotated) symbols 2313 may be [5] mapped (or transformed using, *e.g.*, IFFT or IDFT)” to OFDM symbols at step 2314. *Id.* at 26:51-53.

96. Annotated Figure 27C also shows a preferred embodiment with the same multiple steps:

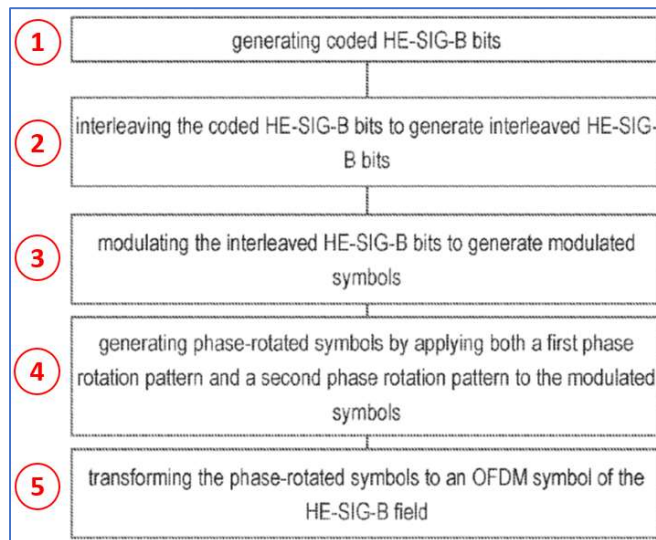

97. The Accused Products transmit and/or receive an HE PPDU with an HE-SIG-B field placed between an HE-SIG-A field and an HE-STF field during normal and intended operation. That HE-SIG-B field is created by a multi-step process, including: (1) generating coded HE-SIG-B bits; (2) interleaving the coded HE-SIG-B bits to generate interleaved HE-SIG-B bits; (3) modulating the interleaved HE-SIG-B bits to generate N modulated symbols; (4) generating N phase-rated symbols by applying a first set of N phase rotation values to the N modulated symbols (*i.e.*, intra-channel phase rotation) and applying a second set of N phase rotation values to the N modulated symbols (*i.e.*, inter-channel phase rotation), resulting in different phase rotations; and (5) transforming the N phase-rotated symbols to an OFDM symbol of the HE-SIG-B field.

98. Defendant directly infringes the apparatus claims of the '058 Patent under 35 U.S.C. § 271(a) by making, using, selling, and/or offering to sell in the United States, and/or importing into the United States products that directly infringe the '058 Patent, including the above identified Accused Products. For example, the Accused AP Products infringe at least claim 1 of the '058 Patent and the Accused STA Products infringe at least claim 7 by practicing the 802.11ax Standard, as indicated in Defendant's marketing materials for the Accused Products. The Accused Products operate as either AP or STA devices that are designed by Vantiva and operate consistent with the requirements of 802.11ax. This includes the claimed ability to transmit/receive HE PPDUs with HE-SIG-B fields having bits that are coded, interleaved, modulated into symbols, subjected to a

two-part phase rotation, and then transformed into OFDM symbols. *See, e.g.*, 802.11ax-2021 § 27.3.11.8.5 (explaining that HE-SIG-B bits are “BCC encoded at rate $R = 1/2$,” “the coded bits are interleaved,” “the interleaved bits are mapped to constellation points from the HE-SIG-B-MCS,” and providing Equation 27-21 where “ $\Gamma_{M_{20}^r(k)}$ is the phase rotation value for HE-SIG-B field PAPR reduction”); § 27.3.6.7 (explaining construction of the HE-SIG-B field, especially the “BCC encoder,” “BCC interleaver,” “Constellation mapper,” and “Duplicate and phase rotation”); § 21.3.7.5 (defining tone rotation); § 27.3.10 (mathematical description of signals). These functions are a mandatory part of the Wi-Fi 6 Standard.

99. Defendant also directly infringes the method claims of the '058 Patent under 35 U.S.C. § 271(a) by using the Accused Products in the United States as described in paragraphs 37-45 above. Users of the Accused AP Products infringe at least claim 11 of the '058 Patent when using those Accused Products to practice the 802.11ax Standard. The Accused AP Products operate as AP devices that are designed by Vantiva and operate consistent with the requirements of 802.11ax. This includes the claimed ability to transmit/receive HE PPDU with HE-SIG-B fields having bits that are coded, interleaved, modulated into symbols, subjected to a two-part phase rotation, and then transformed into OFDM symbols. *See, e.g.*, 802.11ax-2021 § 27.3.11.8.5 (explaining that HE-SIG-B bits are “BCC encoded at rate $R = 1/2$,” “the coded bits are interleaved,” “the interleaved bits are mapped to constellation points from the HE-SIG-B-MCS,” and providing Equation 27-21 where “ $\Gamma_{M_{20}^r(k)}$ is the phase rotation value for HE-SIG-B field PAPR reduction”); § 27.3.6.7 (explaining construction of the HE-SIG-B field, especially the “BCC encoder,” “BCC interleaver,” “Constellation mapper,” and “Duplicate and phase rotation”); § 21.3.7.5 (defining tone rotation); § 27.3.10 (mathematical description of signals). These functions are a mandatory part of the Wi-Fi 6 Standard.

100. For example, Equation 27-21 of the Wi-Fi 6 Standard shows the time domain waveform for the HE-SIG-B field:

$$r_{\text{HE-SIG-B}}^{(i_{\text{seg}}, i_{\text{TX}})}(t) = \frac{1}{\sqrt{N_{\text{TX}} \cdot N_{\text{HE-SIG-B}}^{\text{Tone}} \cdot \frac{\Omega_{20\text{MHz}}}{N_{20\text{MHz}}}}} \sum_{n=0}^{N_{\text{SYM, HE-SIG-B}}-1} w_{T_{\text{HE-SIG-B}}}(t - nT_{\text{SYML}}) \quad (27-21)$$

$$\sum_{i_{\text{BW}} \in \Omega_{20\text{MHz}}} \sum_{k=-28}^{28} \left(\Upsilon_{(k - K_{\text{Shift}}(i_{\text{BW}})), \text{BW}} \left(\Gamma_{M_{20}^r(k)} D_{k, n, i_{\text{BW}}}^{i_{\text{seg}}} + P_{n+4} P_k \right) \cdot \exp(j2\pi(k - K_{\text{Shift}}(i_{\text{BW}}))\Delta_{F, \text{Pre-HE}}(t - nT_{\text{SYML}} - T_{\text{GI, Pre-HE}} - T_{\text{CS}}^{\text{TX}})) \right)$$

where

$\Gamma_{M_{20}^r(k)}$ is the phase rotation value for HE-SIG-B field PAPR reduction. If the HE-SIG-B field is modulated with HE-SIG-B-MCS 0 and DCM=1, then $\Gamma_{M_{20}^r(k)} = 1$. For all other modulation schemes of the HE-SIG-B field,

$$\Gamma_{M_{20}^r(k)} = \begin{cases} 1 & 0 \leq M_{20}^r(k) < 26 \\ (-1)^{M_{20}^r(k)} & 26 \leq M_{20}^r(k) < 52 \end{cases}$$

$N_{\text{HE-SIG-B}}^{\text{Tone}}$ is given in Table 27-16

$K_{\text{Shift}}(i)$ is defined in 21.3.8.2.4

$$D_{k, n, i_{\text{BW}}}^{i_{\text{seg}}} = \begin{cases} 0, & k = 0, \pm 7, \pm 21 \\ d_{M_{20}^r(k), n, (i_{\text{BW}} \bmod 2) + 1}, & \text{otherwise} \end{cases}$$

$$M_{20}^r(k) = \begin{cases} k + 28, & -28 \leq k \leq -22 \\ k + 27, & -20 \leq k \leq -8 \\ k + 26, & -6 \leq k \leq -1 \\ k + 25, & 1 \leq k \leq 6 \\ k + 24, & 8 \leq k \leq 20 \\ k + 23, & 22 \leq k \leq 28 \end{cases}$$

P_k and p_n are defined in 17.3.5.10

$N_{\text{SYM, HE-SIG-B}}$ is the number of OFDM symbols in the HE-SIG-B field

101. In addition to directly infringing the '058 method claims, Defendant also indirectly infringes the '058 Patent claims. Where acts constituting direct infringement of the '058 Patent are not performed by Defendant, such acts constituting direct infringement of the '058 Patent are performed by Defendant's customers or end-users (the direct infringers) who act at the direction and/or control of Defendant, with Defendant's knowledge. Upon information and belief, Defendant intends to cause, and has taken affirmative steps to induce, infringement by importers, online stores, distribution partners, retailers, reseller partners, solution partners, consumers, end users, and other related service providers by at least, *inter alia*, creating advertisements that promote the infringing use of the Accused Products, creating and/or maintaining established distribution channels for the Accused Products into and within the United States, manufacturing

the Accused Products in conformity with U.S. laws and regulations, distributing or making available instructions or manuals for these products to purchasers and prospective buyers, testing wireless networking features in the Accused Products, and/or providing technical support, replacement parts, or services for these products to purchasers in the United States.

102. Atlas is informed and believes, and on that basis alleges, that Defendant indirectly infringes at least claim 11 of the '058 Patent by active inducement in violation of 35 U.S.C. § 271(b), by at least manufacturing, supplying, distributing, selling, and/or offering for sale the Accused Products to their customers with the knowledge and intent that their further making, using, selling, offering to sell, or importing those products would constitute direct infringement of the '058 Patent.

103. For example, Defendant advertises to its customers that it sells products that comply with the 802.11ax Standard. *See, e.g.*, <https://www.vantiva.com/solutions/fiber-gateways/> (last visited Jan. 31, 2024). Defendant also instructs its customers on how to connect the Accused Products to Wi-Fi networks so that they may practice the 802.11ax Standard. Once the Accused Products are installed, they will automatically implement the 802.11ax Standard based upon the hardware and software provided in the Accused Products. Defendant also provides technical support to its customers and end users and encourages them to use the Accused products in an infringing manner. Thus, with full knowledge of the '058 Patent as described in paragraphs 32-36 above, Defendant induced its customers and end users to directly infringe the '058 Patent by using the Accused Products to perform the infringing methods.

104. Defendant's acts of infringement have caused damage to Atlas, and Atlas is entitled to recover from Defendant (or any successor entity to Defendant) the damages sustained by Atlas as a result of Defendant's wrongful acts in an amount subject to proof at trial.

FIFTH COUNT

(Infringement of U.S. Patent No. 9,848,442)

105. Atlas incorporates by reference the allegations set forth in Paragraphs 1-104 of this Complaint as though fully set forth herein.

106. The '442 Patent, entitled "Method for Transmitting and Receiving Frame in Wireless Local Area Network," was duly and lawfully issued on December 19, 2017. Atlas is the owner of all right, title, and interest in the '442 Patent. The '442 Patent was filed on November 10, 2015, as Application No. 14/937,284 and claims the benefit of U.S. Provisional Application No. 62/077,771, filed on November 10, 2014. See <https://patentimages.storage.googleapis.com/7e/52/0f/569a3a08af772e/US9848442.pdf>.

107. The '442 Patent is directed to setting a physical layer ("PHY") level network allocation vector ("NAV") when receiving a high-efficiency ("HE") physical layer protocol data unit ("PPDU") and setting a medium access control ("MAC") level NAV when receiving a legacy PPDU. Certain claims are directed to a transmitting STA device, in which the STA receives a PHY PPDU, and determines whether a received PPDU originated from a basic service set ("BSS") to which the device belongs or originated from a BSS to which the device does not belong. When an Accused STA Device receives an HE PPDU, the Accused STA Device will set a PHY-level virtual carrier sensing using duration information included in the PHY header of the PPDU. When an Accused STA Device receives a legacy PPDU, the Accused STA Device will set a MAC-level virtual carrier sensing using duration information included in the MAC header of the PPDU. Depending on the value of the virtual carrier sensing, the device will then attempt to obtain a transmission opportunity.

108. The Accused STA Products have a processor and a memory storing instructions to receive the aforementioned PHY PPDU, determine the BSS, and adjust the aforementioned settings, and they do in fact receive those frames, make those determinations, and adjust those settings during normal use as intended by Defendant.

109. Defendant directly infringes the '442 Patent under 35 U.S.C. § 271(a) by making, using, selling, and/or offering to sell in the United States, and/or importing into the United States products that directly infringe the '442 Patent, including the above identified Accused Products. The Accused STA Products infringe at least claim 8 of the '442 Patent by practicing the 802.11ax Standard, as indicated in Defendant's marketing material for the Accused Products. The Accused

STA Products operate as Station devices that are designed by Defendant and operate consistent with the requirements of 802.11ax. This includes the claimed ability to receive PHY PPDU, determine the BSS, and adjust the virtual carrier sensing settings. *See, e.g.*, 802.11ax-2021 § 10.3.2.4 (Setting and resetting the NAV); § 10.3.2.1 (CS mechanism); § 10.28.3 (Duration/ID field processing); § 26.2.2 (Intra-BSS and inter-BSS PPDU classification); § 26.2.4 (Updating two NAVs); § 26.10.2.2 (General operation with non-SRG OBSS PD level); § 26.11.5 (TXOP_DURATION); § 27.2.1 (HE PHY service interface: Introduction); § 27.3.4 (HE PPDU formats); § 27.3.22 (HE receive procedure); § 27.3.11.7.1 (HE-SIG-A field); Table 9-9; Table 27-1; Table 27-18; Figure 19-1; Figure 21-4. These functions are a mandatory part of the Wi-Fi 6 Standard.

110. The Accused STA Devices determine whether a received PPDU is inter-BSS or intra-BSS based on criteria specified in the 802.11ax Standard. The 802.11ax Standard provides instructions for a STA to determine whether a PPDU is inter-BSS or intra-BSS. *See* 802.11ax-2021 § 26.2.4 (Intra-BSS and inter-BSS PPDU classification).

111. According to the 802.11ax Standard, when an Accused STA Device receives an HE PPDU that is inter-BSS, the Accused STA Device will set a PHY-level virtual carrier sensing using duration information included in the PHY header of the PPDU. The Accused STA Device uses the TXOP_DURATION parameter from the TXVECTOR as the Duration value. *See* 802.11ax-2021 § 26.2.4 (Updating two NAVs). The Duration value is used to set the PHY-level NAV. *See* 802.11ax-2021 § 27.3.11.7 (HE-SIG-A field).

TXOP_DURATION	FORMAT is HE_SU, HE_MU, HE_ER_SU or HE_TB	Indicates the TXOP duration. Enumerated type or integer: UNSPECIFIED indicates no NAV value specified. 0 – 8448 indicates a value in units of 1 μs that is used to update the NAV for this TXOP (see 26.2.4 (Updating two NAVs)). TXVECTOR parameter TXOP_DURATION is converted to a value in the TXOP subfield of HE-SIG-A (see Table 27-18 (HE-SIG-A field of an HE SU PDU and HE ER SU PDU), Table 27-20 (HE-SIG-A field of an HE MU PDU) and Table 27-21 (HE-SIG-A field of an HE TB PDU)) as follows: TXOP_DURATION = UNSPECIFIED: B0-B6 = 127 TXOP_DURATION < 512: B0 = 0, B1-B6 = ⌊TXOP_DURATION / 8⌋ Otherwise: B0 = 1, B1-B6 = ⌊TXOP_DURATION – 512 / 8⌋ RXVECTOR parameter TXOP_DURATION is determined from the value in the TXOP subfield of HE-SIG-A (see Table 27-18 (HE-SIG-A field of an HE SU PDU and HE ER SU PDU), Table 27-20 (HE-SIG-A field of an HE MU PDU) and Table 27-21 (HE-SIG-A field of an HE TB PDU)) as follows: B0-B6 = 127: TXOP_DURATION = UNSPECIFIED B0 = 0: TXOP_DURATION = 8 × B1-B6 Otherwise: TXOP_DURATION = 512 + 128 × B1-B6 See 26.11.5 (TXOP_DURATION) for more details.	Y	Y
	Otherwise	Not present.	N	N

802.11ax-2021 Table 27-1 (highlighting added).

112. According to the 802.11ax Standard, when an Accused STA Device receives a legacy PDU that is inter-BSS, the Accused STA Device will set a MAC-level virtual carrier sensing using duration information included in the MAC header of the PDU. The MAC header of a legacy PDU contains a "Duration/ID" field." See 802.11ax-2021 § 9.2.3 (General Frame Format). The Accused STA Devices use the Duration value to set the MAC-level NAV. See 802.11ax-2021 § 10.3.2.4 (Setting and resetting the NAV); 802.11ax-2021 § 26.2.4 (Updating two NAVs).

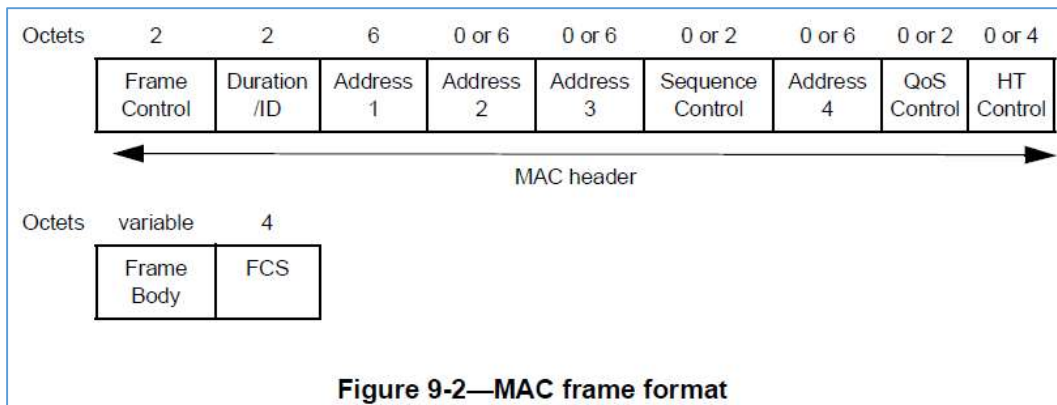

802.11ax-2021 Fig. 9-2.

113. In addition to directly infringing the '442 apparatus claims by making, selling and using infringing products in the United States, Defendant also indirectly infringes the '442 Patent claims. Where acts constituting direct infringement of the '442 Patent are not performed by Defendant, such acts constituting direct infringement of the '442 Patent are performed by Defendant's customers or end-users who act at the direction and/or control of Defendant, with Defendant's knowledge.

114. Atlas is informed and believes, and on that basis alleges, that Defendant indirectly infringes at least claim 8 of the '442 Patent by active inducement in violation of 35 U.S.C. § 271(b), by at least manufacturing, supplying, distributing, selling, and/or offering for sale the Accused Products to their customers and end users of Defendant's Accused Products with the knowledge and intent that their further making, using, selling, offering to sell, or importing those products would constitute direct infringement of the '442 Patent.

115. For example, Defendant advertises to its customers that it sells products that comply with the 802.11ax Standard. *See, e.g.,* <https://www.vantiva.com/solutions/fiber-gateways/> (last visited Jan. 31, 2024). Defendant also instructs its customers on how to connect the Accused Products to Wi-Fi networks so that they may practice the 802.11ax Standard. Once the Accused Products are installed, they will automatically implement the 802.11ax Standard in an infringing manner based upon the hardware and software provided in the Accused Products. Defendant also provides technical support to its customers and end users and encourages them to make, use, sell,

offer to sell, and/or import the Accused Products in an infringing manner. Thus, with full knowledge of the '442 Patent as described in paragraphs 32-36 above, Defendant induced its customers and end users to directly infringe the '442 Patent by making, using, selling, offering to sell, and/or importing the Accused Products.

116. Defendant's acts of infringement have caused damage to Atlas, and Atlas is entitled to recover from Defendant (or any successor entity to Defendant) the damages sustained by Atlas as a result of Defendant's wrongful acts in an amount subject to proof at trial.

SIXTH COUNT

(Infringement of U.S. Patent No. 9,893,790)

117. Atlas incorporates by reference the allegations set forth in Paragraphs 1-116 of this Complaint as though fully set forth herein.

118. The '790 Patent, entitled "Preamble and Payload for High Efficiency (HE) Transmission," was duly and lawfully issued on February 13, 2018. Atlas is the owner of all right, title, and interest in the '790 Patent. The '790 Patent was filed on March 24, 2017 as Application No. 15/469,470. The '790 Patent is a continuation of Application No. 15/136,830, which was filed on April 22, 2016 and issued as U.S. Patent No. 9,641,234. The '790 Patent claims the benefit of U.S. Provisional Application No. 62/152,509, filed on April 24, 2015.

119. The '790 Patent relates to the format of an 802.11ax PPDU. An 802.11ax PPDU comprises both a header and a payload. The header comprises a signal field with length information and information identifying a basic service set. The payload comprises a second length information. As set forth in the '790 Patent, when a station determines that a received 802.11ax PPDU is inter-BSS, the station will use the length information in the header to set a network allocation vector (NAV).

120. Defendant directly infringes the '790 Patent under 35 U.S.C. § 271(a) by making, using, selling, and/or offering to sell in the United States, and/or importing into the United States products that directly infringe the '790 Patent, including the above identified Accused Products. The Accused Products infringe at least claim 1 of the '790 Patent by practicing the 802.11ax

Standard, as indicated in Defendant’s marketing material for the Accused Products. The Accused Products operate as Station devices that are designed by Defendant and operate consistent with the requirements of 802.11ax.

121. The Accused Products comprise one or more memories, and one or more processors coupled to said memories, the processor(s) configured to cause the Accused Products to possess the claimed capabilities, *e.g.*, as described below.

122. The Accused Products comprise receiving a frame, wherein the frame comprises a header and a payload. There are four HE PDU formats disclosed in the 802.11ax Standard: HE SU PDU, HE MU PDU, HE ER SU PDU, and HE TB PDU.

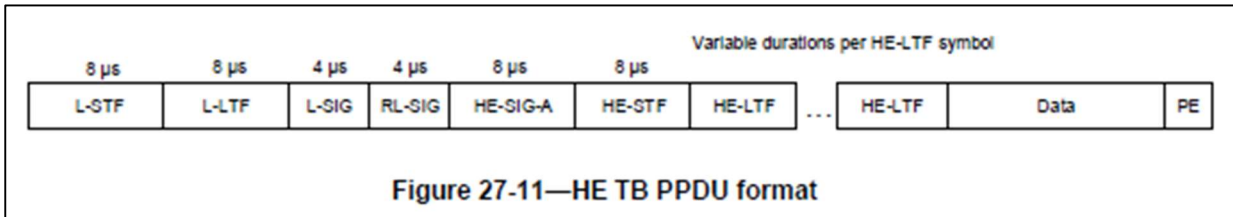
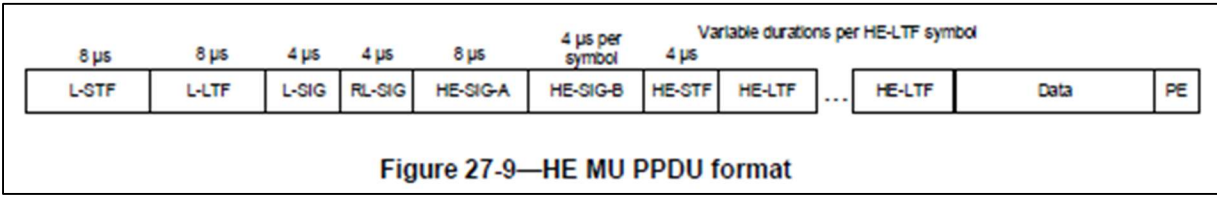

802.11ax-2021 § 27.3.4. The header portion includes the L-STF, L-LTF, L-SIG, RL-SIG, HE-SIG-A, HE-SIG-B, HE-STF, and HE-LTF fields. The payload comprises the Data portion. The RL-SIG, HE-SIG-A, HE-STF, and HE-LTF fields are present in all HE PPDU. The HE-SIG-B field is present only in the HE MU PPDU. *See* 802.11ax-2021 § 27.3.4.

123. The header in the Accused Products comprises a signal field. The signal field includes the L-SIG, RL-SIG, HE-SIG-A, and HE-SIG-B fields. *See* 802.11ax-2021 § 27.3.4.

124. The signal field comprises a first length information and an identifier of a basic service set. Table 27-18 of the 802.11ax Standard describes the HE-SIG-A field of an HE SU PPDU and an HE ER SU PPDU. The HE-SIG-A field comprises the TXOP field, which is a first length information.

B0-B6	TXOP	7	<p>Set to 127 to indicate no duration information.</p> <p>Set to a value less than 127 to indicate the closest minimum bound on the duration information for NAV setting and protection of the TXOP as follows:</p> <p>If B0 is 0, the TXOP duration indicated is B1-B6, in units of 8 μs.</p> <p>If B0 is 1, the TXOP duration indicated is B1-B6, in units of 128 μs, plus 512 μs.</p> <p>See TXVECTOR parameter TXOP_DURATION.</p>
-------	------	---	--

802.11ax-2021 § 27.3.11.7.2. The HE-SIG-A field also comprises a BSS Color field, which is an identifier of a basic service set.

B8-B13	BSS Color	6	<p>An identifier of the BSS.</p> <p>See TXVECTOR parameter BSS_COLOR.</p>
--------	-----------	---	---

802.11ax-2021 § 27.3.11.7.2. Those same fields are present in every HE PPDU. *See* 802.11ax-2021 at Table 27-20 (HE MU PPDU); Table 27-21 (HE TB PPDU).

125. The Accused Products comprise a payload with a second length information. As explained above, the payload is the Data field of an HE PPDU. The Data field comprises the MAC header, which includes the Duration/ID field. The Duration field is the second length information.

TXOP_DURATION value from the HE-SIG-A field. The 802.11ax Standard explains that TXOP_DURATION “indicates duration information for NAV setting and protection of the TXOP except that the TXVECTOR parameter TXOP_DURATION is set to UNSPECIFIED to indicate no duration information.” *See* 802.11ax-2021 § 26.11.5. The second length information is the Duration field in the MAC header. The “Duration/ID field of the frame can set a network allocation vector (NAV) value at receiving STAs that protects up to the end of any following Data, Management, or response frame plus any additional overhead frames.” 802.11-2020 § 9.2.5.2. The 802.11ax Standard explains that the TXOP_DURATION value and the Duration value are the same, except that TXOP_DURATION can never exceed 8448. 802.11ax-2021 § 26.11.5.

129. In addition to directly infringing the ’790 apparatus claims by making, selling and using infringing products in the United States, Defendant also indirectly infringes the ’790 Patent claims. Where acts constituting direct infringement of the ’790 Patent are not performed by Defendant, such acts constituting direct infringement of the ’790 Patent are performed by Defendant’s customers or end-users who act at the direction and/or control of Defendant, with Defendant’s knowledge.

130. Atlas is informed and believes, and on that basis alleges, that Defendant indirectly infringes at least claim 9 of the ’790 Patent by active inducement in violation of 35 U.S.C. § 271(b), by at least manufacturing, supplying, distributing, selling, and/or offering for sale the Accused Products to their customers and end users of Defendant’s Accused Products with the knowledge and intent that their further making, using, selling, offering to sell, or importing those products would constitute direct infringement of the ’790 Patent.

131. For example, Defendant advertises to its customers that it sells products that comply with the 802.11ax Standard. *See, e.g.,* <https://www.vantiva.com/solutions/fiber-gateways/> (last visited Jan. 31, 2024). Defendant also instructs its customers on how to connect the Accused Products to Wi-Fi networks so that they may practice the 802.11ax Standard. Once the Accused Products are installed, they will automatically implement the 802.11ax Standard in an infringing manner based upon the hardware and software provided in the Accused Products. Defendant also

provides technical support to its customers and end users and encourages them to make, use, sell, offer to sell, and/or import the Accused Products in an infringing manner. Thus, with full knowledge of the '790 Patent as described in paragraphs 32-36 above, Defendant induced its customers and end users to directly infringe the '790 Patent by making, using, selling, offering to sell, and/or importing the Accused Products.

132. Defendant's acts of infringement have caused damage to Atlas, and Atlas is entitled to recover from Defendant (or any successor entity to Defendant) the damages sustained by Atlas as a result of Defendant's wrongful acts in an amount subject to proof at trial.

SEVENTH COUNT

(Infringement of U.S. Patent No. 10,020,919)

133. Atlas incorporates by reference the allegations set forth in Paragraphs 1-132 of this Complaint as though fully set forth herein.

134. The '919 Patent, entitled "Protection Methods for Wireless Transmissions," was duly and lawfully issued on July 10, 2018. Atlas is the owner of all right, title, and interest in the '919 Patent. The '919 Patent was filed on April 25, 2017 as Application No. 15/497,094 as a continuation of Application No. 15/291,947, filed on October 12, 2016 (which resulted in U.S. Patent No. 9,667,394), and further claims the benefit of U.S. Provisional Application No. 62/333,192, filed on May 7, 2016, U.S. Provisional Application No. 62/333,077, filed on May 6, 2016, U.S. Provisional Application No. 62/331,380, filed on May 3, 2016, and U.S. Provisional Application No. 62/240,419, filed on October 12, 2015. *See* <https://patentimages.storage.googleapis.com/c3/70/58/d1b5e3ee57d660/US10020919.pdf>.

135. The '919 Patent generally relates to an access point soliciting Channel State Information ("CSI") from one or more stations using a Null Data Packet Announcement (indicating which stations should send CSI) followed by a Null Data Packet, after which either a single station responds, or multiple stations wait for an indication they should respond (in response to a polling or trigger frame). The '919 Patent discloses a CSI feedback procedure, also known as sounding procedure, that consists of a transmission, by the beamformer (such as an access point),

of a non-data packet announcement (NDPA) transmission followed by non-data packet (NDP). In response to the NDPA transmission and the NDP, a beamformee (such as a station) transmits CSI feedback to the beamformer. The '919 Patent teaches multiple procedures for providing CSI feedback, including: (1) a single user provides CSI feedback using a UL Single-User (SU) MIMO transmission, or (2) a plurality of users provide CSI feedback simultaneously using an UL MU transmission. The procedure that is used is indicated by a number of per-station information fields in the NDPA frame. The NDPA frame contains parameters for CSI feedback as well as list of STAs that are directed to participate in the CSI feedback process. Thus, the '919 Patent teaches a technique which supports UL MU transmission while avoiding the overhead of a trigger frame when only soliciting CSI information from a single station. The Accused AP Products and the Accused STA Products are configured and designed to implement the above sounding procedure, and they do in fact implement that sounding procedure during normal use as intended by Defendant.

136. Defendant directly infringes the method claims of the '919 Patent under 35 U.S.C. § 271(a) by using the Accused Products in the United States as described in paragraphs 37-45 above. Users of the Accused Products infringe at least claims 1 and 11 of the '919 Patent when using those Accused Products to practice the 802.11ax Standard. This includes performing a sounding procedure where the Accused STA Products receive null data packet announcements with one or more station information fields, followed by null data packets. When there is only a single station information field in the null data packet announcement, the Accused STA Products are required to transmit a CSI feedback report. *See e.g.*, 802.11ax-2021 § 26.7 (HE Sounding protocol); § 9.3.1.19 (VHT/HE NDP Announcement Frame Format); Figures 9-61a, 26-7, 26-8. This also includes performing a sounding procedure where the Accused AP Products generate and transmit null data packet announcements with one or more station information fields, followed by null data packets. When there is only a single station information field in the null data packet announcement, that receiving station is required to transmit a CSI feedback report. *See e.g.*,

802.11ax-2021 § 26.7 (HE Sounding protocol); § 9.3.1.19 (VHT/HE NDP Announcement Frame Format); Figures 9-61a, 26-7, 26-8. These functions are a mandatory part of the Wi-Fi 6 Standard.

137. For example, Figure 26-7 of the Wi-Fi 6 standard shows an STA (referred to as a “HE beamformee”), such as one of Defendant’s Accused STA products, receiving a null data packet announcement frame from an AP device (referred to as a “HE beamformer”), such as one of Defendant’s Accused AP products.

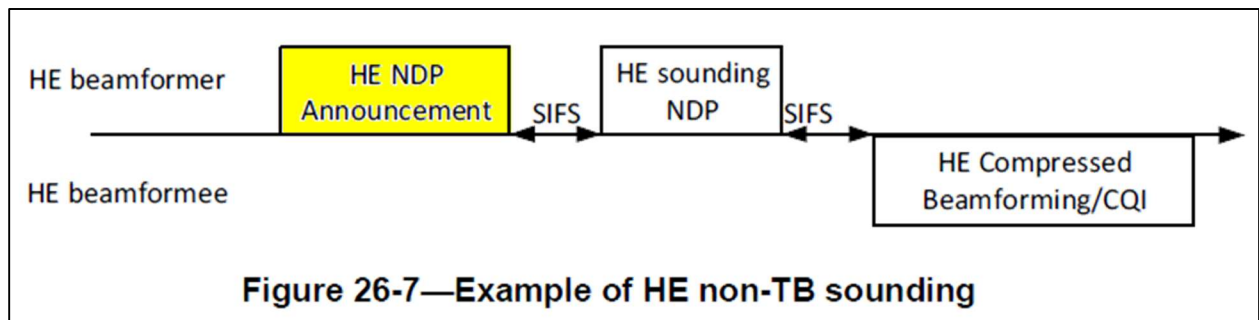

802.11ax-2021 Fig. 26-7. Figure 9-61 shows the format of a null data packet announcement frame.

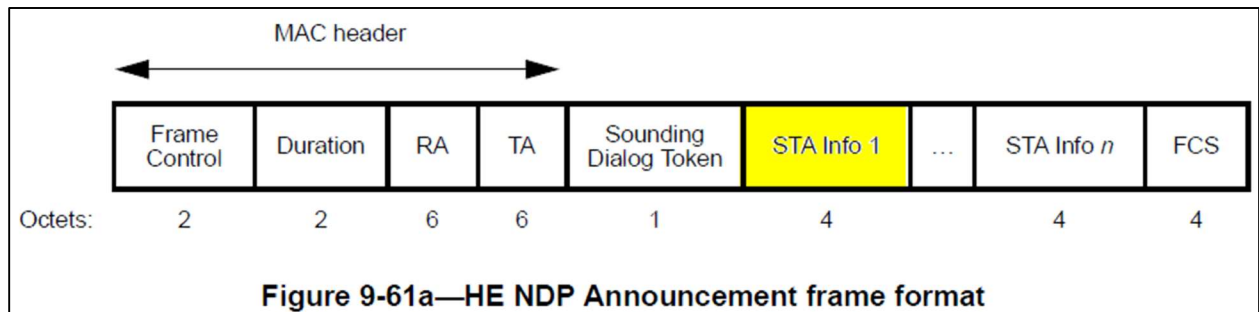

802.11ax-2021 Fig. 9-61. If the null data packet announcement frame was only intended for a single station as in Figure 26-7, there will only be a single station information field (“STA Info 1”) in the NDPA transmitted by the Accused AP Product. Thus, the number of station information fields is the cardinality of the set of STA Info fields in the HE NDPA. Thereafter, the Accused AP Product transmits a null data packet (referred to in Figure 26-7 above as a “HE sounding NDP”) to the STA. Then, the STA will transmit a channel state information feedback report (referred to in Figure 26-7 above as a “HE Compressed Beamforming/CQI”), and the Accused AP Product will receive it.

138. In addition to directly infringing the '919 method claims, Defendant also indirectly infringes the '919 Patent claims. Where acts constituting direct infringement of the '919 Patent are not performed by Defendant, such acts constituting direct infringement of the '919 Patent are performed by Defendant's customers or end-users (the direct infringers) who act at the direction and/or control of Defendant, with Defendant's knowledge. Upon information and belief, Defendant intends to cause, and has taken affirmative steps to induce, infringement by importers, online stores, distribution partners, retailers, reseller partners, solution partners, consumers, end users, and other related service providers by at least, *inter alia*, creating advertisements that promote the infringing use of the Accused Products, creating and/or maintaining established distribution channels for the Accused Products into and within the United States, manufacturing the Accused Products in conformity with U.S. laws and regulations, distributing or making available instructions or manuals for these products to purchasers and prospective buyers, testing wireless networking features in the Accused Products, and/or providing technical support, replacement parts, or services for these products to purchasers in the United States.

139. Atlas is informed and believes, and on that basis alleges, that Defendant indirectly infringes at least claims 1 and 11 of the '919 Patent by active inducement in violation of 35 U.S.C. § 271(b), by at least manufacturing, supplying, distributing, selling, and/or offering for sale the Accused Products to their customers and end users with the knowledge and intent that their further making, using, selling, offering to sell, or importing those products would constitute direct infringement of the '919 Patent.

140. For example, Defendant advertises to its customers that it sells products that comply with the 802.11ax Standard. *See, e.g.*, <https://www.vantiva.com/solutions/fiber-gateways/> (last visited Jan. 31, 2024). Defendant also instructs its customers on how to connect the Accused Products to Wi-Fi networks so that they may practice the 802.11ax Standard. Once the Accused Products are installed, they will automatically implement the 802.11ax Standard in an infringing based upon the hardware and software provided in the Accused Products. Defendant also provides technical support to its customers and end users and encourages them to use the Accused products

in an infringing manner. Thus, with full knowledge of the '919 Patent as described in paragraphs 32-36 above, Defendant induced its customers and end users to directly infringe the '919 Patent by using the Accused Products to perform the infringing methods.

141. Defendant's acts of infringement have caused damage to Atlas, and Atlas is entitled to recover from Defendant (or any successor entity to Defendant) the damages sustained by Atlas as a result of Defendant's wrongful acts in an amount subject to proof at trial.

EIGHTH COUNT

(Infringement of U.S. Patent No. 10,327,172)

142. Atlas incorporates by reference the allegations set forth in Paragraphs 1-141 of this Complaint as though fully set forth herein.

143. The '172 Patent, entitled "Long Training Field Sequence Construction," was duly and lawfully issued on June 18, 2019. Atlas is the owner of all right, title, and interest in the '310 Patent. The '310 Patent was filed on March 7, 2017, as Application No. 15/452,567 and claims the benefit of U.S. Application No. 15 /079,007, filed on March 23, 2016, now Pat. No. 9,628,310, U.S. Provisional Application No. 62/214,139, filed on September 3, 2015, U.S. Provisional Application No. 62/214,156, filed on September 3, 2015, U.S. Provisional Application No. 62/157,849, filed on May 6, 2015, U.S. Provisional Application No. 62/236,815, filed on October 2, 2015, U.S. Provisional Application No. 62/250,944, filed on November 4, 2015, U.S. Provisional Application No. 62/264, 812, filed on December. 8, 2015, and U.S. Provisional Application No. 62/138,302, filed on March 25, 2015. *See* <https://patentimages.storage.googleapis.com/87/08/6d/faf8d6bf89c1a5/US10327172.pdf>.

144. The '172 Patent relates to generating a long training field sequence in 802.11ax. In 802.11ax, an HE frame is associated with one of the channel bandwidths, either 20 MHz, 40 MHz, 80 MHz, 160 MHz, or 80+80 MHz (where the 80 MHz channels are not contiguous). The Accused STA Products are designed and configured to receive an HE-LTF symbol in a 20 MHz channel bandwidth and obtain an HE-LTF sequence corresponding to the channel bandwidth and HE-LTF mode. In both cases, the HE-LTF mode of the HE-LTF symbol can be one of a plurality of HE-

LTF modes including a 4xHE-LTF mode and a 2x HE-LTF mode. Similarly, the Accused AP Products are designed and configured to transmit an HE-LTF symbol in a 20 MHz channel bandwidth by using an HE-LTF sequence corresponding to the channel bandwidth and HE-LTF mode.

145. Defendant directly infringes the '172 Patent under 35 U.S.C. § 271(a) by making, using, selling, and/or offering to sell in the United States, and/or importing into the United States products that directly infringe the '172 Patent, including the above identified Accused Products. The Accused Products infringe at least claims 1 and 14 of the '172 Patent by practicing the 802.11ax Standard, as indicated in Defendant's marketing material for the Accused Products. The Accused Products operate as Access Point devices or Station devices that are designed by Defendant and operate consistent with the requirements of 802.11ax. For the Accused Products, this includes the claimed ability to wirelessly communicate in a 20 MHz channel bandwidth, determine an HE-LTF mode, generate an HE-LTF symbol by using an HE-LTF sequence corresponding to the HE-LTF mode, and transmit an HE-PPDU including that HE-LTF symbol. *See, e.g.*, 802.11ax-2021 § 4.3.15a (channel bandwidths); § 27.3.11.10 (HE-LTF modes); § 27.3.11.10 (plurality of HE-LTF sequences); § 27.3.4 (HE PPDU structure); § 4.3.15a. ("Support for 20 MHz operating channel width is mandatory in an HE STA").

146. The Accused Products have one or more memories, and one or more processors coupled to said memories, the processor configured to cause the Accused Product to possess the claimed capabilities, *e.g.* as described herein.

147. The Accused Products obtain a high efficiency long training field (HE-LTF) mode among a plurality of HE-LTF modes including a 4x HE-LTF mode and a 2x HE-LTF mode. For example, An HE PPDU supports 3 HE-LTF modes: 1x HE-LTF, 2x HE-LTF, and 4x HE-LTF. 802.11ax-2021 § 27.3.11.10. Table 27-31 defines the HE-LTF and GI duration combinations for various HE PPDU formats:

Table 27-31—HE-LTF type and GI duration combinations for various HE PPDU formats

HE-LTF type and GI duration combination	HE SU PPDU	HE MU PPDU	HE ER SU PPDU	HE TB PPDU	HE sounding NDP	HE TB feedback NDP
1x HE-LTF 0.8 μ s GI	O	N/A	O	N/A	N/A	N/A
1x HE-LTF 1.6 μ s GI	N/A	N/A	N/A	CM3	N/A	N/A
2x HE-LTF 0.8 μ s GI	M	M	M	N/A	M	N/A
2x HE-LTF 1.6 μ s GI	M	M	M	M	M	N/A
4x HE-LTF 0.8 μ s GI	CM1	CM2	O	N/A	N/A	N/A
4x HE-LTF 3.2 μ s GI	M	M	M	M	O	M

Legend
M = mandatory.
CM1 = Mandatory if the STA supports 4x HE-LTF 0.8 μ s GI for HE ER SU PPDU. Otherwise, optional.
CM2 = For an AP, mandatory for transmission if the AP supports 4x HE-LTF 0.8 μ s GI for HE ER SU PPDU. For a non-AP STA, mandatory for reception if the non-AP STA supports 4x HE-LTF 0.8 μ s GI for HE ER SU PPDU. Otherwise, optional.
CM3 = Mandatory for full-bandwidth UL MU-MIMO if the STA supports UL MU-MIMO. Otherwise, not supported. N/A for partial-bandwidth UL MU-MIMO or UL OFDMA.
O = optional.
N/A = not supported by the PPDU format.

If a STA does not support transmission or reception of a particular PPDU format, then the M/CM/O designation is not applicable for the transmission or reception, respectively, of that PPDU format.

802.11ax-2021 Table 27-31.

148. The Accused Products generate an HE-LTF symbol by using a portion or an entirety of an HE-LTF sequence corresponding to the 20 MHz channel bandwidth and the determined HE-LTF mode. When an Accused Product receives an HE PPDU, it obtains an HE-LTF sequence corresponding to an HE-LTF mode, as shown above. The Accused Product obtains the sequence based on an HE-LTF symbol corresponding to the 20 MHz channel bandwidth and HE-LTF mode. 802.11ax-2021 § 27.3.11.10. For example, the HE-LTF sequences for the 20 MHz bandwidth and 2x HE-LTF mode and 4x HE-LTF mode are given in tables 27-42 and 27-43:

$$\begin{aligned}
 & \text{HELTF}_{-122,122} = \\
 & \{-1, 0, -1, 0, -1, 0, +1, 0, +1, 0, -1, 0, +1, 0, -1, 0, -1, 0, -1, 0, +1, 0, -1, 0, +1, 0, \\
 & -1, 0, -1, 0, +1, 0, +1, 0, -1, 0, +1, 0, +1, 0, +1, 0, +1, 0, -1, 0, +1, 0, -1, 0, +1, 0, \\
 & -1, 0, -1, 0, +1, 0, +1, 0, -1, 0, +1, 0, -1, 0, -1, 0, -1, 0, +1, 0, -1, 0, +1, 0, +1, 0, \\
 & +1, 0, -1, 0, -1, 0, +1, 0, -1, 0, -1, 0, -1, 0, -1, 0, +1, 0, -1, 0, -1, 0, -1, 0, +1, 0, \\
 & +1, 0, +1, 0, -1, 0, -1, 0, +1, 0, 0, 0, +1, 0, -1, 0, +1, 0, +1, 0, -1, 0, +1, 0, +1, 0, -1, 0, \\
 & +1, 0, +1, 0, -1, 0, -1, 0, +1, 0, -1, 0, +1, 0, +1, 0, +1, 0, +1, 0, -1, 0, +1, 0, -1, 0, +1, 0, \\
 & +1, 0, -1, 0, -1, 0, +1, 0, -1, 0, -1, 0, -1, 0, -1, 0, +1, 0, -1, 0, +1, 0, +1, 0, -1, 0, \\
 & -1, 0, +1, 0, +1, 0, -1, 0, +1, 0, -1, 0, -1, 0, -1, 0, -1, 0, +1, 0, -1, 0, +1, 0, +1, 0, +1, 0, \\
 & -1, 0, -1, 0, +1, 0, -1, 0, -1, 0, -1, 0, -1, 0, -1, 0, +1, 0, -1, 0, +1, 0, -1, 0, +1\}
 \end{aligned} \tag{27-42}$$

$$\begin{aligned}
 & \text{HELTF}_{-122,122} = \\
 & \{-1, -1, +1, -1, +1, -1, +1, +1, +1, -1, +1, +1, +1, -1, -1, +1, -1, -1, -1, -1, -1, +1, +1, \\
 & -1, -1, -1, -1, +1, +1, -1, +1, -1, +1, +1, +1, +1, -1, +1, -1, -1, +1, +1, -1, +1, +1, +1, \\
 & +1, -1, -1, +1, -1, -1, -1, +1, +1, +1, +1, -1, +1, +1, -1, -1, -1, -1, +1, -1, -1, +1, +1, \\
 & -1, +1, -1, -1, -1, -1, +1, -1, +1, -1, -1, -1, -1, -1, -1, +1, +1, -1, -1, -1, -1, +1, \\
 & -1, -1, +1, +1, +1, -1, +1, +1, +1, -1, +1, -1, +1, -1, -1, -1, -1, +1, +1, +1, -1, -1, \\
 & -1, +1, -1, +1, +1, +1, 0, 0, 0, -1, +1, -1, +1, -1, +1, +1, -1, +1, +1, +1, -1, -1, +1, -1, \\
 & -1, +1, -1, +1, -1, +1, +1, +1, -1, +1, +1, +1, -1, -1, +1, -1, -1, -1, -1, +1, +1, -1, \\
 & -1, -1, -1, -1, -1, +1, -1, +1, -1, -1, -1, -1, +1, -1, +1, +1, -1, -1, +1, -1, -1, -1, \\
 & +1, +1, -1, +1, +1, +1, +1, +1, +1, +1, -1, +1, +1, -1, -1, -1, -1, +1, -1, -1, +1, +1, -1, \\
 & +1, -1, -1, -1, -1, +1, -1, +1, -1, -1, +1, +1, +1, +1, -1, -1, +1, +1, +1, +1, +1, -1, +1, \\
 & +1, -1, -1, -1, +1, -1, -1, -1, +1, -1, +1, -1, +1, +1\}
 \end{aligned} \tag{27-43}$$

A plurality of different HE-LTF sequences based on the various bandwidth and mode combinations are given in equations 27-41 through 27-52.

149. In the Accused Products, the HE-LTF sequence is among a plurality of HE-LTF sequences for the plurality of bandwidths and the plurality of HE-LTF modes (*See, e.g.*, equations 27-41 through 27-52), wherein the HE-LTF sequence includes zero values on every odd subcarrier index of a first range of subcarrier indices and a second range of subcarrier indices, non-zero values on every even subcarrier index of the first range and the second range, and direct current tones on subcarrier indices of a third range of subcarrier indices. For example, in the 20 MHz 2x HE-LTF mode, a first range is shown in green, a second range is shown in blue, and a third range is shown in yellow:

$$\begin{aligned}
 &HELTF_{-122,122} = \\
 &\{-1, 0, -1, 0, -1, 0, +1, 0, +1, 0, -1, 0, +1, 0, -1, 0, -1, 0, -1, 0, -1, 0, +1, 0, -1, 0, +1, 0, \\
 &-1, 0, -1, 0, +1, 0, +1, 0, -1, 0, +1, 0, +1, 0, +1, 0, +1, 0, -1, 0, +1, 0, -1, 0, +1, 0, \\
 &-1, 0, -1, 0, +1, 0, +1, 0, -1, 0, +1, 0, -1, 0, -1, 0, -1, 0, -1, 0, +1, 0, -1, 0, +1, 0, +1, 0, \\
 &+1, 0, -1, 0, -1, 0, +1, 0, -1, 0, -1, 0, -1, 0, -1, 0, +1, 0, -1, 0, -1, 0, -1, 0, +1, 0, \\
 &+1, 0, +1, 0, -1, 0, -1, 0, +1, 0, 0, 0, 0, +1, 0, -1, 0, +1, 0, +1, 0, -1, 0, +1, 0, +1, 0, -1, 0, \\
 &+1, 0, +1, 0, -1, 0, -1, 0, +1, 0, -1, 0, +1, 0, +1, 0, +1, 0, +1, 0, -1, 0, +1, 0, -1, 0, +1, 0, \\
 &+1, 0, -1, 0, -1, 0, +1, 0, -1, 0, -1, 0, -1, 0, -1, 0, -1, 0, +1, 0, -1, 0, +1, 0, +1, 0, -1, 0, \\
 &-1, 0, +1, 0, +1, 0, -1, 0, +1, 0, -1, 0, -1, 0, -1, 0, -1, 0, +1, 0, -1, 0, +1, 0, +1, 0, +1, 0, \\
 &-1, 0, -1, 0, +1, 0, -1, 0, -1, 0, -1, 0, -1, 0, -1, 0, -1, 0, +1, 0, -1, 0, +1, 0, +1, 0, +1, 0\}
 \end{aligned}
 \tag{27-42}$$

As shown, the sequence includes zero values on every odd subcarrier index in the first and second ranges, includes non-zero values on every even subcarrier index in the first and second ranges, and includes direct current tones on subcarrier indices of the third range.

150. The Accused Products transmit a high efficiency physical layer protocol data unit (HE PDU) including the HE-LTF symbol, in the 20 MHz channel bandwidth. For example, the HE PDU is transmitted including an HE-LTF symbol using the appropriate HE-LTF sequence, as illustrated in Figures 27-8 through 27-11:

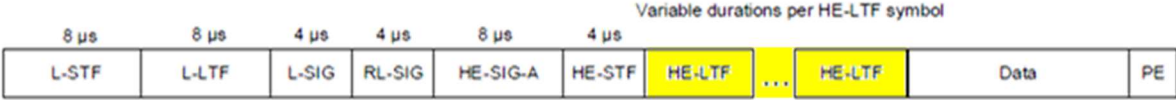

Figure 27-8—HE SU PDU format

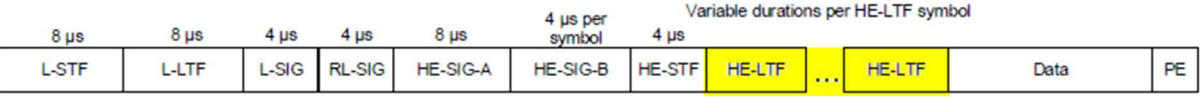

Figure 27-9—HE MU PDU format

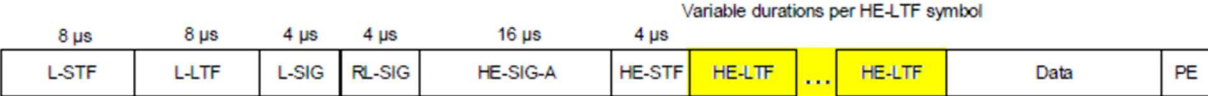
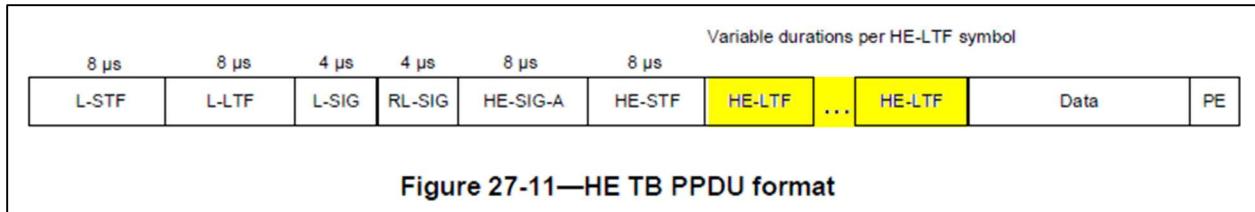

Figure 27-10—HE ER SU PDU format



151. In addition to directly infringing the '172 apparatus claims by making, selling and using infringing products in the United States, Defendant also indirectly infringes the '172 Patent claims. Where acts constituting direct infringement of the '172 Patent are not performed by Defendant, such acts constituting direct infringement of the '172 Patent are performed by Defendant's customers or end-users who act at the direction and/or control of Defendant, with Defendant's knowledge.

152. Atlas is informed and believes, and on that basis alleges, that Defendant indirectly infringes at least claims 1 and 14 of the '172 Patent by active inducement in violation of 35 U.S.C. § 271(b), by at least manufacturing, supplying, distributing, selling, and/or offering for sale the Accused Products to their customers and end users of Defendant's Accused Products with the knowledge and intent that their further making, using, selling, offering to sell, or importing those products would constitute direct infringement of the '172 Patent.

153. For example, Defendant advertises to its customers that it sells products that comply with the 802.11ax Standard. *See, e.g.*, <https://www.vantiva.com/solutions/fiber-gateways/> (last visited Jan. 31, 2024). Defendant also instructs its customers on how to connect the Accused Products to Wi-Fi networks so that they may practice the 802.11ax Standard. Once the Accused Products are installed, they will automatically implement the 802.11ax Standard in an infringing manner based upon the hardware and software provided in the Accused Products. Defendant also provides technical support to its customers and end users and encourages them to make, use, sell, offer to sell, and/or import the Accused Products in an infringing manner. Thus, with full knowledge of the '172 Patent as described in paragraphs 32-36 above, Defendant induced its customers and end users to directly infringe the '172 Patent by making, using, selling, offering to sell, and/or importing the Accused Products.

154. Defendant's acts of infringement have caused damage to Atlas, and Atlas is entitled to recover from Defendant (or any successor entity to Defendant) the damages sustained by Atlas as a result of Defendant's wrongful acts in an amount subject to proof at trial.

NINTH COUNT

(Infringement of U.S. Patent No. 11,050,539)

155. Atlas incorporates by reference the allegations set forth in Paragraphs 1-154 of this Complaint as though fully set forth herein.

156. The '539 Patent, entitled "Pilot Transmission and Reception for Orthogonal Frequency Division Multiple Access," was duly and lawfully issued on June 29, 2021. Atlas is the owner of all right, title, and interest in the '539 Patent. The '539 Patent was filed on March 11, 2020, as Application No. 16/816,092 and claims the benefit of U.S. Provisional Application No. 62/159,187, filed on May 8, 2015, Application No. 15/150,127, filed on May 9, 2016, now U.S. Patent No. 9,621,311, Application No. 15/444,188, filed on February 27, 2017, now U.S. Patent No. 10,361,828, and Application No. 16/443,683, filed on June 17, 2019, now U.S. Patent No. 10,630,444. See <https://patentimages.storage.googleapis.com/5e/06/09/67d12572b8fe36/US11050539.pdf>

157. The '539 Patent relates to the provision of pilot subcarriers within resources units in 802.11ax. In 802.11ax, HE transmissions are associated with one of the channel bandwidths, either 20 MHz, 40 MHz, 80 MHz, 160 MHz, or 80+80 MHz (where the 80 MHz channels are not contiguous). These channels are further subdivided into resource units ("RUs"). 802.11ax defines seven types of resource units based on the number of tones that make up the resource unit: tone RU, 52-tone RU, 106-tone RU, 242-tone RU, 484-tone RU, 996-tone RU, and 2×996-tone RU. Each RU is comprised of subcarriers, including data subcarriers and pilot subcarriers. The Accused AP products are designed and configured to transmit a frame including a plurality of resource units and pilots according to the 802.11ax specification. Similarly, the Accused STA products are designed and configured to receive a frame including a plurality of resource units and pilots

according to the 802.11ax specification. In both cases, the positions of the pilot tones are set in part based on the number of subcarriers in the resource unit.

158. Defendant directly infringes the '539 Patent under 35 U.S.C. § 271(a) by making, using, selling, and/or offering to sell in the United States, and/or importing into the United States products that directly infringe the '539 Patent, including the above identified Accused Products. The Accused Products infringe at least claims 1, 10 and 19 of the '310 Patent by practicing the 802.11ax Standard, as indicated in Defendant's marketing material for the Accused Products. The Accused Products operate as Access Point devices or Station devices that are designed by Defendant and operate consistent with the requirements of 802.11ax. For the Accused Products, this includes the claimed ability to set pilot tone positions based in part on the number of tones in a resource unit. *See, e.g.*, 802.11ax-2021 § 27.3.2 (subcarrier and resource allocation); § 27.3.10 (mathematical description of signals); § 27.3.12.13 (Pilot subcarriers). These functions are a mandatory part of the Wi-Fi 6 Standard.

159. The Accused Products have one or more memories, and one or more processors coupled to said memories, the processor configured to cause the Accused Product to possess the claimed capabilities, *e.g.*, as described below.

160. During normal intended operation, the Accused AP Products are designed to determine a set of resource units for a frame, including 26-tone RUs, 52-tone RUs, 106-tone RUs, or 242-tone RUs. The Accused AP Products then provide a number of pilot subcarriers in the selected RU. The position of the pilot subcarriers is set based on the number of subcarriers in the resource unit. For example, Table 27-7 of 802.11ax explains that in the 20 MHz band, there are nine possible RUs that can be transmitted by an AP:

Table 27-7—Data and pilot subcarrier indices for RUs in a 20 MHz HE PDU and in a non-OFDMA 20 MHz HE PDU

RU type	RU index and subcarrier range				
26-tone RU	RU 1 [-121: -96]	RU 2 [-95: -70]	RU 3 [-68: -43]	RU 4 [-42: -17]	RU 5 [-16: -4, 4: 16]
	RU 6 [17: 42]	RU 7 [43: 68]	RU 8 [70: 95]	RU 9 [96: 121]	
52-tone RU	RU 1 [-121: -70]	RU 2 [-68: -17]	RU 3 [17: 68]	RU 4 [70: 121]	
106-tone RU	RU 1 [-122: -17]		RU 2 [17: 122]		
242-tone RU	RU 1 [-122: -2, 2: 122]				
<p>NOTE 1—The subcarrier index of 0 corresponds to the DC tone. Negative subcarrier indices correspond to subcarriers with a frequency lower than the DC tone, and positive subcarrier indices correspond to subcarriers with a frequency higher than the DC tone.</p> <p>NOTE 2—RU 5 is the middle 26-tone RU.</p>					

802.11ax § 27.3.2.2 (Resource unit, guard, and DC subcarriers). Table 27-7 also provides different numbers of RUs and subcarrier ranges for 52-tone, 106-tone, and 242-tone RUs using the 20MHz bandwidth. *Id.* 802.11ax includes similar charts for the remaining 40 MHz and 80 MHz bandwidths. *Id.*

161. Once the set of RUs is determined, the Accused AP Product provides a plurality of pilots in the RUs as specified in 802.11ax. For example, Table 27-37 of 802.11ax identifies the pilot indices for a 26-tone RU in each of the transmission bandwidths:

Table 27-37—Pilot indices for a 26-tone RU

PPDU BW	K_{R26}
20 MHz, $i = 1:9$	{-116, -102}, {-90, -76}, {-62, -48}, {-36, -22}, {-10, 10}, {22, 36}, {48, 62}, {76, 90}, {102, 116}
40 MHz, $i = 1:18$	{-238, -224}, {-212, -198}, {-184, -170}, {-158, -144}, {-130, -116}, {-104, -90}, {-78, -64}, {-50, -36}, {-24, -10}, {10, 24}, {36, 50}, {64, 78}, {90, 104}, {116, 130}, {144, 158}, {170, 184}, {198, 212}, {224, 238}
80 MHz, $i = 1:37$	{-494, -480}, {-468, -454}, {-440, -426}, {-414, -400}, {-386, -372}, {-360, -346}, {-334, -320}, {-306, -292}, {-280, -266}, {-252, -238}, {-226, -212}, {-198, -184}, {-172, -158}, {-144, -130}, {-118, 104}, {-92, -78}, {-64, -50}, {-38, -24}, {-10, 10}, {24, 38}, {50, 64}, {78, 92}, {104, 118}, {130, 144}, {158, 172}, {184, 198}, {212, 226}, {238, 252}, {266, 280}, {292, 306}, {320, 334}, {346, 360}, {372, 386}, {400, 414}, {426, 440}, {454, 468}, {480, 494}
160 MHz, $i = 1:74$	{pilot subcarrier indices in 80 MHz -512, pilot subcarrier indices in 80 MHz +512}

802.11ax § 27.3.12.13 (Pilot subcarriers). As illustrated above, each 26-tone RU in the 20MHz band includes two subcarrier indices positioned within the RU index. Using the 20MHz bandwidth for example, RU 7, which is comprised of subcarriers at indices 43 to 68, the pilot subcarriers are indexed at 48 and 62. Similarly, in RU 8, which is comprised of subcarriers at indices 70 to 95, the pilot subcarriers are indexed at 76 and 90. In these 26-tone RUs, when the lowest index is odd, the pilot subcarriers are positioned five subcarriers away from the lowest index subcarriers. And, when the lowest index is even, the pilot subcarriers are positioned six subcarriers away from the lowest index subcarrier. This is illustrated by Fig. 70 of the '539 Patent, which has been annotated below to use the indices of RU 7 and RU 8:

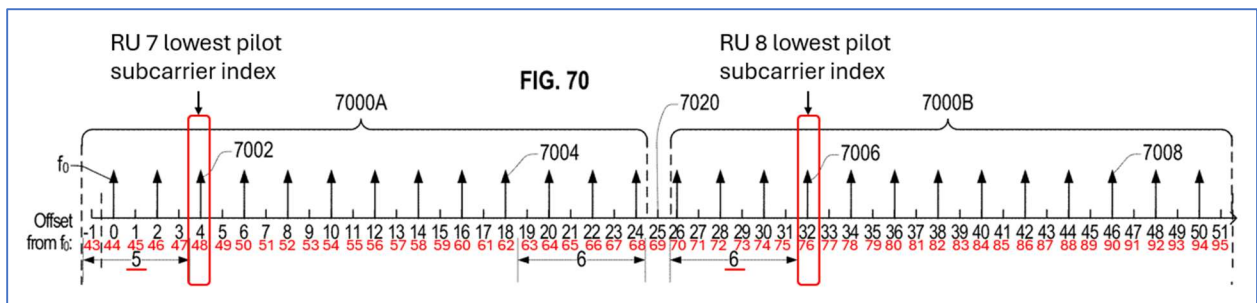

162. Finally, 802.11ax explains that when a higher tone RU is used, the pilot tones are placed in different locations compared to the lower to RU. For example, Table 27-39 of 802.11ax identifies the pilot indices of a 52-tone RU in each of the transmission bandwidths:

Table 27-39—Pilot indices for 52-tone RU transmission

PPDU BW	K_{R52_i}
20 MHz, $i = 1:4$	{-116, -102, -90, -76}, {-62, -48, -36, -22}, {22, 36, 48, 62}, {76, 90, 102, 116}
40 MHz, $i = 1:8$	{-238, -224, -212, -198}, {-184, -170, -158, -144}, {-104, -90, -78, -64}, {-50, -36, -24, -10}, {10, 24, 36, 50}, {64, 78, 90, 104}, {144, 158, 170, 184}, {198, 212, 224, 238}
80 MHz, $i = 1:16$	{-494, -480, -468, -454}, {-440, -426, -414, -400}, {-360, -346, -334, -320}, {-306, -292, -280, -266}, {-252, -238, -226, -212}, {-198, -184, -172, -158}, {-118, -104, -92, -78}, {-64, -50, -38, -24}, {24, 38, 50, 64}, {78, 92, 104, 118}, {158, 172, 184, 198}, {212, 226, 238, 252}, {266, 280, 292, 306}, {320, 334, 346, 360}, {400, 414, 426, 440}, {454, 468, 480, 494}
160 MHz, $i = 1:32$	{pilot subcarrier indices in 80 MHz -512, pilot subcarrier indices in 80 MHz +512}

802.11ax § 27.3.12.13 (Pilot subcarriers). When compared to Table 27-37, *supra*, the pilot indices for the 52-tone RU are placed at four indices in the RU (as opposed to two), and those pilot indices include the indices for the 26-tone RUs. The same is true for each higher tone RU and in each bandwidth of 802.11ax.

163. Once the Accused AP Product determines and provides the above RU and pilot indices, the Accused AP Product transmits a frame to a receiving STA. Conversely, During normal intended operation, the Accused STA Products are designed to receive a frame from an AP the includes RUs with pilot tones corresponding to scheme described above with respect to the Accused AP Products.

164. In addition to directly infringing the '539 apparatus claims by making, selling and using infringing products in the United States, Defendant also indirectly infringes the '539 Patent claims. Where acts constituting direct infringement of the '539 Patent are not performed by Defendant, such acts constituting direct infringement of the '539 Patent are performed by Defendant's customers or end-users who act at the direction and/or control of Defendant, with Defendant's knowledge.

165. Atlas is informed and believes, and on that basis alleges, that Defendant indirectly infringes at least claims 1, 10, and 19 of the '539 Patent by active inducement in violation of 35 U.S.C. § 271(b), by at least manufacturing, supplying, distributing, selling, and/or offering for sale the Accused Products to their customers and end users of Defendant's Accused Products with the

knowledge and intent that their further making, using, selling, offering to sell, or importing those products would constitute direct infringement of the '539 Patent.

166. For example, Defendant advertises to its customers that it sells products that comply with the 802.11ax Standard. *See, e.g.*, <https://www.vantiva.com/solutions/fiber-gateways/> (last visited Jan. 31, 2024). Defendant also instructs its customers on how to connect the Accused Products to Wi-Fi networks so that they may practice the 802.11ax Standard. Once the Accused Products are installed, they will automatically implement the 802.11ax Standard in an infringing manner based upon the hardware and software provided in the Accused Products. Defendant also provides technical support to its customers and end users and encourages them to make, use, sell, offer to sell, and/or import the Accused Products in an infringing manner. Thus, with full knowledge of the '539 Patent as described in paragraphs 32-36 above, Defendant induced its customers and end users to directly infringe the '539 Patent by making, using, selling, offering to sell, and/or importing the Accused Products.

167. Defendant's acts of infringement have caused damage to Atlas, and Atlas is entitled to recover from Defendant (or any successor entity to Defendant) the damages sustained by Atlas as a result of Defendant's wrongful acts in an amount subject to proof at trial.

WILLFULNESS

168. Prior to the filing of this complaint, and certainly by the date of this Complaint, Defendant knew or should have known that it infringed the Asserted Patents.

169. As a company in the wireless electronics space, and more particularly a manufacturer of Wi-Fi 6 products, Defendant is familiar with the Wi-Fi 6 Standard and the process by which it was adopted by the IEEE. For example, Defendant knows that companies contribute technical submissions to the IEEE for inclusion in the Wi-Fi 6 Standard, and if IEEE members deem those contributions meritorious, they are incorporated into the Wi-Fi 6 Standard. Defendant also knows that the companies are permitted to obtain patents on their contributions to the Wi-Fi 6 Standard. Defendant further knows that Newracom was a major contributor to the Wi-Fi 6 Standard and one of the leaders in both number of technical submissions and number of adopted

submissions to the Wi-Fi 6 Standard. Defendant also knows that Newracom obtained nearly two hundred patents covering its contributions to the Wi-Fi 6 Standard, including the Asserted Patents.

170. Defendant also knew of the Asserted Patents at least by June 20, 2021, when Atlas specifically notified Defendant of them as described in paragraphs 32-36 above. More specifically, on that date, Atlas sent letters presenting Defendant “with an opportunity for Technicolor to license Standard Essential Patents (SEP) in Wi-Fi 6—the latest generation of Wi-Fi technology.” Exs. A-C. Further, Atlas informed Defendant that the Asserted Patents “cover[] key improvements in Wi-Fi technology developed by Newracom’s internal R&D team and adopted in the 802.11ax Wi-Fi standard.” *Id.* In those initial June 20, 2021 letters and the conversations thereafter, Atlas specifically invited Defendant to license the Asserted Patents. *Id.* Despite all the above, Defendant refused to take a license for the Asserted Patents. Once it became clear that Defendant would not voluntarily take a license to the Asserted Patents, Atlas was forced to resort to litigation.

171. Defendant has therefore proceeded to infringe the Asserted Patents with full and complete knowledge of their applicability to Defendant’s Accused Wi-Fi 6 Products without taking a license and without a good faith belief that the patents-in-suit are invalid and not infringed. At minimum, Defendant willfully blinded itself to its infringement of the Asserted Patents; Defendant believed with high probability that its Wi-Fi 6 products infringed but took deliberate action to avoid learning further details of its infringement.

172. Defendant’s infringement of the Asserted Patents thus occurs with knowledge of infringement, objective recklessness, and/or willful blindness, and has been and continues to be willful and deliberate. Thus, Defendant’s infringement of the patents-in-suit is willful and deliberate, entitling Atlas to increased damages under 35 U.S.C. § 284 and to attorneys’ fees and costs incurred in prosecuting this action under 35 U.S.C. § 285.

PRAYER FOR RELIEF

WHEREFORE, Plaintiff prays for judgment and seeks relief against Defendant as follows:

(a) For judgment that U.S. Patent Nos. ’520, ’310, ’234, ’058, ’442, ’790, ’919, ’172, and ’539 have been and continue to be infringed by Defendant;

(b) For an accounting of all damages sustained by Plaintiff as the result of Defendant's acts of infringement;

(c) For finding that Defendant's infringement is willful and enhancing damages pursuant to 35 U.S.C. § 284;

(d) For a mandatory future royalty payable on each and every future sale by Defendant of a product that is found to infringe one or more of the Asserted Patents and on all future products that are not colorably different from products found to infringe;

(e) For an award of attorneys' fees pursuant to 35 U.S.C. § 285 or otherwise permitted by law;

(f) For all costs of suit; and

(g) For such other and further compensatory relief as the Court may deem just and proper.

DEMAND FOR JURY TRIAL

Pursuant to Rule 38(b) of the Federal Rules of Civil Procedure and Local Rule CV-38, Plaintiff demands a trial by jury of this action.

Dated: February 29, 2024

Respectfully submitted,

/s/ Michael F. Heim

Max L. Tribble Jr.

Texas Bar No. 20213950

mtribble@susmangodfrey.com

Joseph S. Grinstein

Texas Bar No. 24002188

jgrinstein@susmangodfrey.com

Alejandra C. Salinas

Texas Bar No. 24102452

asalinas@susmangodfrey.com

SUSMAN GODFREY LLP

1000 Louisiana Street, Suite 5100

Houston, Texas 77002

Telephone: (713) 651-9366

Facsimile: (713) 654-6666

Kalpana Srinivasan

CA State Bar No. 237460

ksrinivasan@susmangodfrey.com

Oleg Elkhunovich

CA State Bar No. 269238

oelkhunovich@susmangodfrey.com

SUSMAN GODFREY LLP

1900 Avenue of the Stars, Suite 1400

Los Angeles, California 90067

Telephone: (310) 789-3100

Facsimile: (310) 789-3150

Alexander W. Aiken

WA State Bar No. 55988

aaiken@susmangodfrey.com

SUSMAN GODFREY LLP

401 Union Street, Suite 3000

Seattle, WA 98101

Telephone: (206) 516-3880

Facsimile: (206) 516-3883

Robert Greenfeld
NY State Bar No. 2824811
rgreenfeld@susmangodfrey.com
SUSMAN GODFREY LLP
1301 Avenue of the Americas, 32nd Floor
New York, NY 10019
Telephone: (212) 336-8330
Facsimile: (212) 336-8340

Michael F. Heim
Texas Bar No. 09380923
mheim@hpcllp.com
Eric J. Enger
Texas Bar No. 24045833
eenger@hpcllp.com
Blaine A. Larson
Texas Bar No. 24083360
blarson@hpcllp.com
Alden G. Harris
Texas Bar No. 24083138
aharris@hpcllp.com
William B. Collier, Jr.
Texas Bar No. 24097519
wcollier@hpcllp.com
HEIM, PAYNE & CHORUSH, LLP
609 Main Street, Suite 3200
Houston, Texas 77002
Telephone: (713) 221-2000
Facsimile: (713) 221-2021

T. John Ward, Jr.
TX State Bar No. 00794818
Email: jw@wsfirm.com
Andrea L. Fair
TX State Bar No. 24078488
Email: andrea@wsfirm.com
Ward, Smith & Hill, PLLC
1507 Bill Owens Parkway
Longview, Texas 75604
Telephone: 903-757-6400
Facsimile: 903-7572323

S. Calvin Capshaw
Texas State Bar No. 03783900
Elizabeth L. DeRieux
Texas State Bar No. 05770585
CAPSHAW DeRIEUX, LLP
114 E. Commerce Ave.
Gladewater, TX 75647
Telephone: (903) 845-5770
Email: ccapshaw@capshawlaw.com
Email: ederieux@capshawlaw.com

*ATTORNEYS FOR
ATLAS GLOBAL TECHNOLOGIES LLC*