

**IN THE UNITED STATES DISTRICT COURT
FOR THE SOUTHERN DISTRICT OF NEW YORK**

Endobotics, LLC,

Plaintiff,

v.

FUJIFILM Healthcare Americas Corporation,

Defendant.

Case No.

JURY TRIAL DEMANDED

Plaintiff Endobotics, LLC (“Endobotics”) hereby alleges against defendant FUJIFILM Healthcare Americas Corporation (“FUJIFILM”) on personal knowledge as to its own activities and on information and belief as to all other matters, as follows:

NATURE OF THE ACTION

1. This is an action for patent infringement under the laws of the United States, 35 U.S.C. §§ 100, *et seq.*
2. This action arises from FUJIFILM’s import, manufacture, use, offer for sale, and sale in the United States of products – including FUJIFILM’s “TRACMOTION” surgical instruments – that infringe claims of two of Endobotics’s patents.

PARTIES

3. Endobotics, LLC is a Delaware limited liability company having a principal place of business in Southampton, New York.
4. FUJIFILM Healthcare Americas Corporation is a New York corporation having a place of business in Valhalla, New York.

JURISDICTION AND VENUE

5. This Court has subject matter jurisdiction under 28 U.S.C. §§ 1331 and 1338(a).

6. This Court has personal jurisdiction over FUJIFILM because, upon information and belief, FUJIFILM is a New York corporation, has availed itself of the rights and benefits of the laws of New York, has derived substantial revenue from the sales of its products in New York, has systematic and continuous business contacts with New York, and/or has a principal place of business in this District and has committed at least some of the infringing acts alleged herein in New York.

7. Venue is proper in this action pursuant to 28 U.S.C. §§ 1391, 1400(b) at least because FUJIFILM resides in this District and/or has committed acts of infringement in this District and has a regular and established place of business in this District.

THE PATENTS-IN-SUIT

8. U.S. Patent No. 7,147,650 (the “’650 Patent;” copy attached as Exhibit A), entitled “Surgical Instrument,” was duly issued on December 12, 2006, and remains unexpired.

9. U.S. Patent No. 7,364,582 (the “’582 Patent;” copy attached as Exhibit B), entitled “Surgical Instrument,” was duly issued on April 29, 2008, and remains unexpired.

10. Endobotics is the sole owner by assignment of all right, title, and interest in and to the ’650 Patent and the ’582 Patent (collectively, the “Endobotics Patents”), including all right to recover for any and all infringement of the Endobotics Patents.

THE ACCUSED PRODUCTS

11. FUJIFILM imports, makes, uses, offers for sale, and/or sells products in the United States that infringe each of the Endobotics Patents.

12. For example, as shown below, FUJIFILM imports, makes, uses, offers for sale, and/or sells products in its “TRACMOTION” product line (including model/product no. GF3612RT, as shown below) (collectively, the “Accused Products”).



COUNT I: INFRINGEMENT OF U.S. PATENT NO. 7,147,650

13. Endobotics repeats and realleges all previous paragraphs as if fully incorporated herein.

14. FUJIFILM infringes one or more claims of the '650 Patent, including but not limited to claim 111, either literally or under the doctrine of equivalents, by making, using, selling, offering for sale, or importing into the U.S. the Accused Products.

15. The Accused Products embody each element of at least one of the claims of the '650 Patent, including claim 111.

16. By making, using, selling, offering for sale, and/or importing the Accused Products (which meet all the limitations of at least claim 111 of the '650 Patent), FUJIFILM infringes the '650 Patent, in violation of 35 U.S.C. § 271(a).

17. For example, each of the Accused Products is (or includes) a surgical instrument that includes an elongated instrument shaft having proximal and distal ends, including as shown

below (image showing elongated instrument shaft of the Accused Products):



18. Each of the Accused Products includes a tool disposed from the distal end of the instrument shaft, including as shown below (image showing tool of the Accused Products disposed from the distal end of the instrument shaft):



19. Each of the Accused Products includes a control handle disposed from the proximal end of the instrument shaft, including as shown below (image showing control handle of the Accused Products):

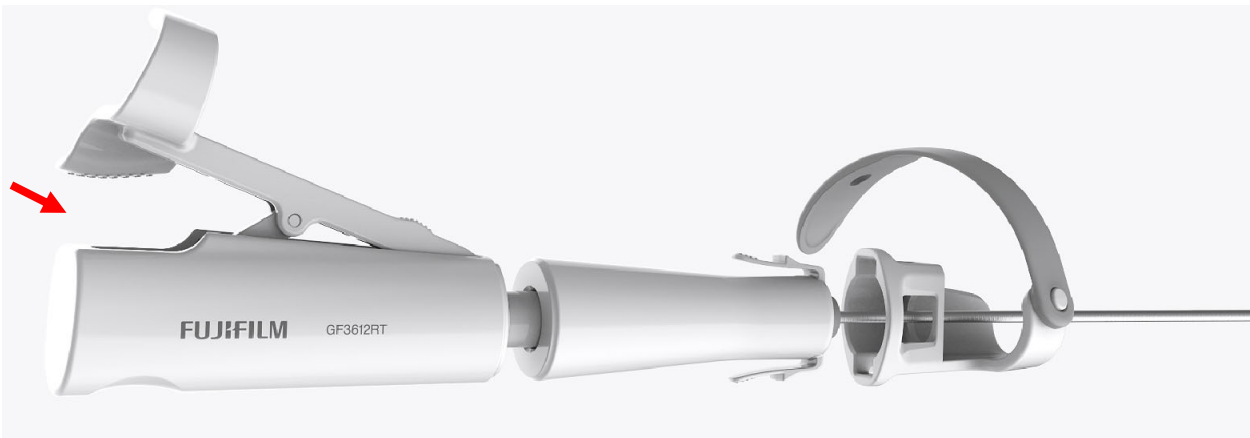

20. Each of the Accused Products further includes a distal bendable member for coupling the distal end of said elongated instrument shaft to said tool, including as shown below (image showing distal bendable member of the Accused Products):



21. Each of the Accused Products further includes a proximal bendable member for coupling the proximal end of said elongated instrument shaft to said handle, said proximal bendable member having a diameter that is different than the diameter of said distal bendable member, including as shown below (image showing proximal bendable member of the Accused Products having a diameter that is different than the diameter of said distal bendable member):

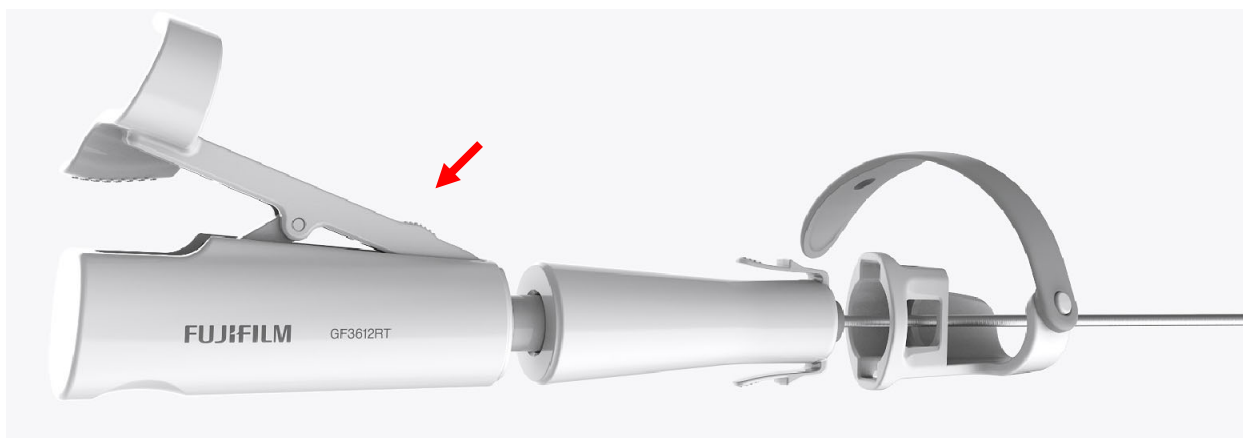

22. Each of the Accused Products further includes actuation means extending between said distal and proximal bendable members for coupling motion of said proximal bendable member to said distal bendable member for controlling the positioning of said tool, including as shown below (images showing aspects of operation of actuation means of the Accused Products):

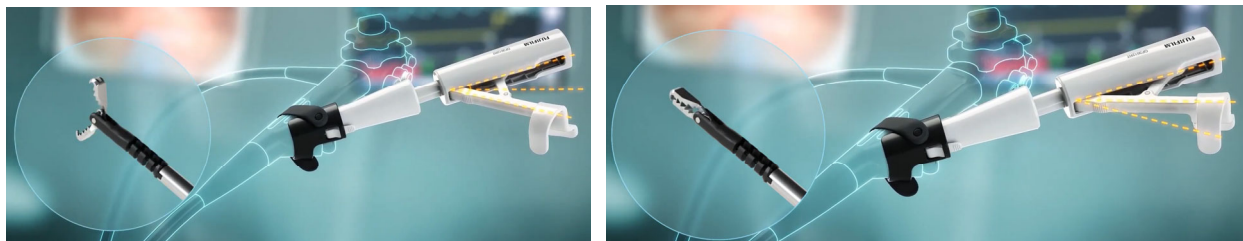

23. This description is based on publicly available information and a reasonable investigation of the structure and operation of the Accused Products. Endobotics reserves the right to modify this description, including, for example, on the basis of information about the Accused Products obtained during discovery.

24. FUJIFILM also indirectly infringes the '650 Patent within the United States by inducement under 35 U.S.C. § 271(b).

25. Since learning of the '650 Patent, at least by the filing of this Complaint, and by failing to cease offering the Accused Products, FUJIFILM has knowingly and intentionally induced, and continues to knowingly and intentionally to induce, others in this judicial district and

throughout the U.S., including but not limited to FUJIFILM's customers and/or ultimate end users, to directly infringe one or more claims of the '650 Patent such as claim 111.

26. FUJIFILM does so, *inter alia*, by (1) providing instructions or information to explain how to use the Accused Products in an infringing manner (including, for example, via promotional materials and videos such as those provided on FUJIFILM's websites); and (2) touting these infringing uses of the Accused Products in FUJIFILM's advertisements and other public content.

27. Upon information and belief, FUJIFILM also indirectly infringes the '650 Patent by contributing to the direct infringement of FUJIFILM's customers and/or ultimate end users under 35 U.S.C. § 271(c) by offering to sell, selling, and/or importing into the United States a component of the Accused Products, or a material or apparatus for use in practicing a process claimed in the '650 Patent, that constitutes a material part of the inventions, knowing the same to be especially made or especially adapted for use in an infringement of the '650 Patent, and is not a staple article or commodity of commerce suitable for substantial noninfringing use.

28. FUJIFILM's infringement has damaged and continues to damage Endobotics in an amount yet to be determined, of at least a reasonable royalty and/or the lost profits that Endobotics would have made but for FUJIFILM's acts of infringement.

29. Endobotics has been and continues to be injured by FUJIFILM's infringement of the '650 Patent.

30. Endobotics has suffered damages in the form of lost profits, lost sales, and/or lost opportunities. Endobotics is entitled to recover damages to compensate it for FUJIFILM's infringing activities in an amount to be determined at trial, but in no event less than a reasonable royalty.

31. Endobotics has been damaged by FUJIFILM's infringement of the '650 Patent and will suffer additional irreparable damage and impairment of the value of its patent rights unless FUJIFILM is enjoined from continuing to infringe.

32. FUJIFILM's infringement has been and continues to be deliberate, willful, intentional, egregious, and with knowledge of the '650 Patent, at least as of the filing of this Complaint, such that Endobotics is entitled to recover its attorneys' fees and other expenses of litigation pursuant to 35 U.S.C. § 285.

COUNT II: INFRINGEMENT OF U.S. PATENT NO. 7,364,582

33. Endobotics repeats and realleges all previous paragraphs as if fully incorporated herein.

34. FUJIFILM infringes one or more claims of the '582 Patent, including but not limited to claim 41, either literally or under the doctrine of equivalents, by making, using, selling, offering for sale, or importing into the U.S. the Accused Products.

35. The Accused Products embody each element of at least one of the claims of the '582 Patent, including claim 41.

36. By making, using, selling, offering for sale, and/or importing the Accused Products (which meet all the limitations of at least claim 41 of the '582 Patent), FUJIFILM infringes the '582 Patent, in violation of 35 U.S.C. § 271(a).

37. For example, each of the Accused Products is (or includes) a surgical instrument that includes an elongated instrument shaft having proximal and distal ends, including as shown below (image showing elongated instrument shaft of the Accused Products).



38. Each of the Accused Products includes a tool disposed from the distal end of the instrument shaft, including as shown below (image showing tool of the Accused Products disposed from the distal end of the instrument shaft).



39. Each of the Accused Products includes a control handle disposed from the proximal end of the instrument shaft, including as shown below (image showing control handle of the Accused Products).

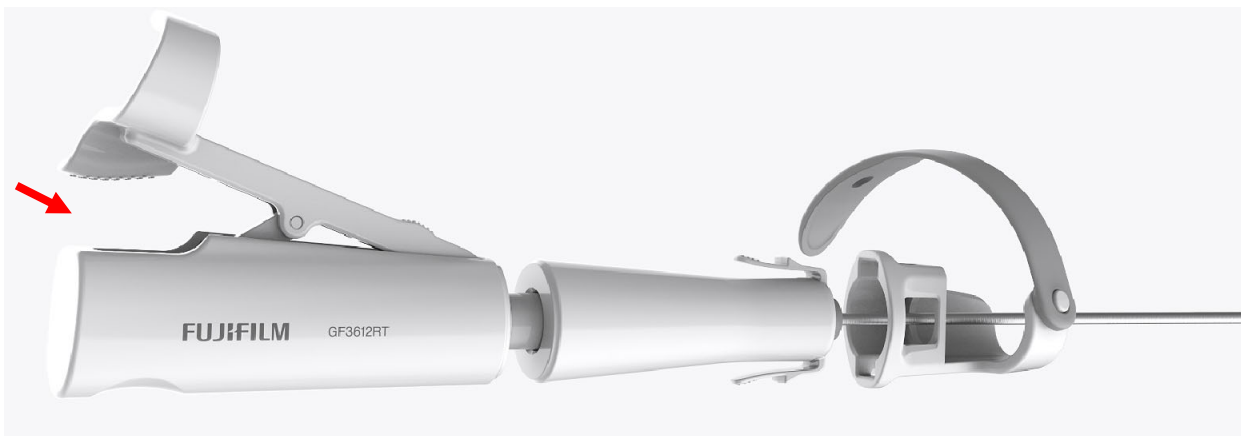

40. Each of the Accused Products includes a distal bendable member for coupling the distal end of said elongated instrument shaft to said tool, including as shown below (images showing distal bendable member of the Accused Products).

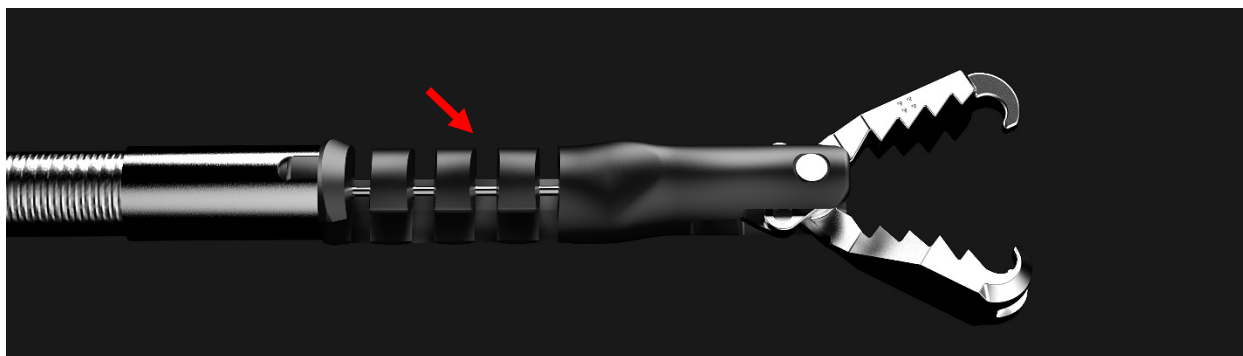

41. Each of the Accused Products includes a proximal bendable member for coupling the proximal end of said elongated instrument shaft to said handle, said proximal bendable member having a maximum transverse cross-sectional dimension that is different than that of said distal bendable member, including as shown below (image showing proximal bendable member of the Accused Products).

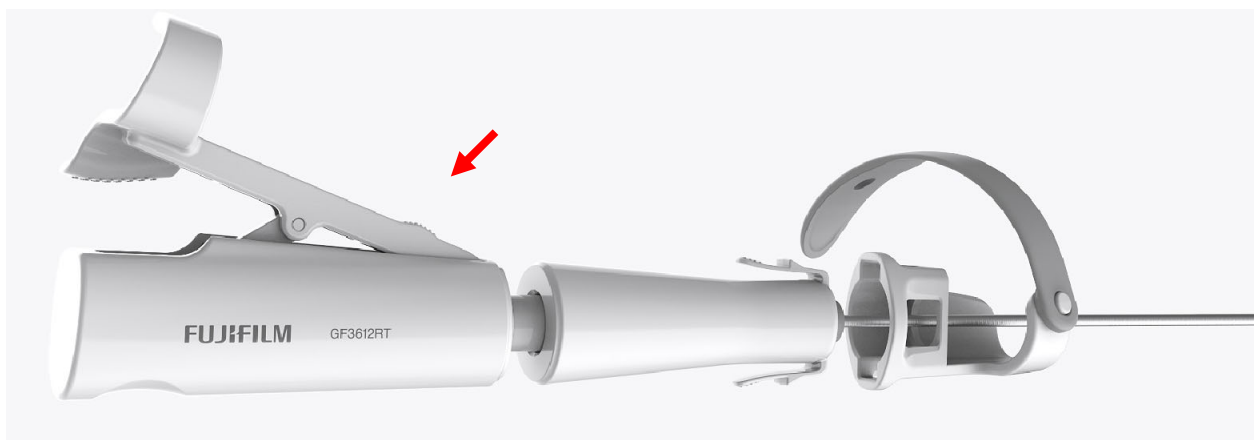

42. Each of the Accused Products includes actuation means extending between said distal and proximal bendable members for coupling motion of said proximal bendable member to said distal bendable member for controlling the positioning of said tool, including as shown below (images showing aspects of operation of actuation means of the Accused Products).

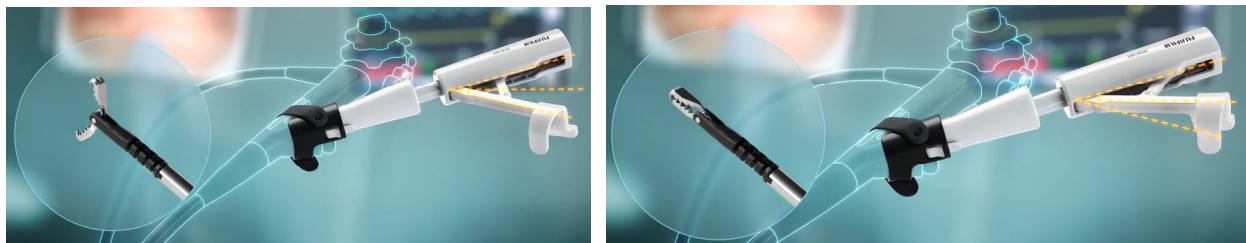

43. This description is based on publicly available information and a reasonable investigation of the structure and operation of the Accused Products. Endobotics reserves the right to modify this description, including, for example, on the basis of information about the Accused Products obtained during discovery.

44. FUJIFILM also indirectly infringes the '582 Patent within the United States by inducement under 35 U.S.C. § 271(b).

45. Since learning of the '582 Patent, at least by the filing of this Complaint, and by failing to cease offering the Accused Products, FUJIFILM has knowingly and intentionally induced, and continues to knowingly and intentionally to induce, others in this judicial district and

throughout the U.S., including but not limited to FUJIFILM's customers and/or ultimate end users, to directly infringe one or more claims of the '582 Patent such as claim 41.

46. FUJIFILM does so, *inter alia*, by (1) providing instructions or information to explain how to use the Accused Products in an infringing manner (including, for example, via promotional materials and videos such as those provided on FUJIFILM's websites); and (2) touting these infringing uses of the Accused Products in FUJIFILM's advertisements and other public content.

47. Upon information and belief, FUJIFILM also indirectly infringes the '582 Patent by contributing to the direct infringement of FUJIFILM's customers and/or ultimate end users under 35 U.S.C. § 271(c) by offering to sell, selling, and/or importing into the United States a component of the Accused Products, or a material or apparatus for use in practicing a process claimed in the '582 Patent, that constitutes a material part of the inventions, knowing the same to be especially made or especially adapted for use in an infringement of the '582 Patent, and is not a staple article or commodity of commerce suitable for substantial noninfringing use.

48. FUJIFILM's infringement has damaged and continues to damage Endobotics in an amount yet to be determined, of at least a reasonable royalty and/or the lost profits that Endobotics would have made but for FUJIFILM's acts of infringement.

49. Endobotics has been and continues to be injured by FUJIFILM's infringement of the '582 Patent.

50. Endobotics has suffered damages in the form of lost profits, lost sales, and/or lost opportunities. Endobotics is entitled to recover damages to compensate it for FUJIFILM's infringing activities in an amount to be determined at trial, but in no event less than a reasonable royalty.

51. Endobotics has been damaged by FUJIFILM's infringement of the '582 Patent and will suffer additional irreparable damage and impairment of the value of its patent rights unless FUJIFILM is enjoined from continuing to infringe.

52. FUJIFILM's infringement has been and continues to be deliberate, willful, intentional, egregious, and with knowledge of the '582 Patent, at least as of the filing of this Complaint, such that Endobotics is entitled to recover its attorneys' fees and other expenses of litigation pursuant to 35 U.S.C. § 285.

JURY DEMAND

Endobotics requests a trial by jury on all issues so triable by right.

PRAYER FOR RELIEF

Endobotics respectfully requests that this Court find in its favor against FUJIFILM and that the Court:

- a. Grant judgment in favor of Endobotics and against FUJIFILM on all of Endobotics's claims, including adjudging that FUJIFILM has infringed, actively induced infringement of, and contributorily infringed each of the Endobotics Patents, in violation of 35 U.S.C. § 271;
- b. Grant an injunction temporarily, preliminarily, and permanently enjoining FUJIFILM, their employees, agents, officers, directors, attorneys, successors, affiliates, subsidiaries, and assigns, and all of those in active concert and participation with any of the foregoing persons or entities from:
 - i. Infringing, contributing to the infringement of, or inducing infringement any of the Endobotics Patents;
 - ii. assisting, aiding, or abetting any other person or business entity in engaging in

- or performing any of the aforementioned activities; and
- iii. making, using, selling, or offering for sale in the United States, or importing into the United States, products or services that infringe any of the Endobotics Patents;
- c. Order FUJIFILM to account and pay damages adequate to compensate Endobotics for FUJIFILM's infringement of the Endobotics Patents, including for any infringing acts not presented at trial and pre-judgment and post-judgment interest and costs, pursuant to 35 U.S.C. § 284;
- d. Increase the amount of damages and/or profits awarded to Endobotics, as provided by law, including but not limited to ordering an accounting for any infringing sales not presented at trial and an award by the Court of additional damages for any such infringing sales;
- e. Increase the damages awarded to Endobotics up to three times the amount found to be its actual damages, as authorized by 35 U.S.C. § 284;
- f. Award Endobotics the fees, costs, and disbursements, and interest, expended in connection with any actions taken to investigate and confirm the claims made herein;
- g. Declare this case exceptional and award Endobotics its reasonable attorneys' fees, pursuant to 35 U.S.C. § 285; and
- h. Awarding such other and further relief as this Court deems just and proper.

Dated: March 26, 2024

BOCHNER PLLC

/s/ Ariel Reinitz

Andrew D. Bochner

Ariel Reinitz

1040 Ave. of the Americas

15th Floor
New York, NY 10018
(646) 971-0685
andrew@bochner.law
ariel@bochner.law

*Attorneys for Plaintiff
Endobotics*