

Gregory D. Phillips (4645)  
Jared L. Cherry (11534)  
PCFB LAW  
4001 S. 700 E., Suite 500  
Salt Lake City, UT 84107  
Tel:(801)935-4933  
Fax:(801)935-4936  
[gdp@pcfblaw.com](mailto:gdp@pcfblaw.com)

Ruoting Men, Esq.  
(To be admitted *pro hac vice*)  
GLACIER LAW LLP  
41 Madison Ave., Suite 2529  
New York, NY 10010  
T: (312) 270-0413  
F: (312) 801-4587  
[Ruoting.men@glacier.law](mailto:Ruoting.men@glacier.law)

Attorneys for Plaintiff

---

UNITED STATES DISTRICT COURT  
DISTRICT OF UTAH, CENTRAL DIVISION

---

Shenzhen Mengdan Technology Co., Ltd, a  
Chinese Limited Liability Company

Plaintiff,

v.

RVLock & Co., LLC, a Utah Limited Liability  
Company

Defendant.

CASE NO.

JUDGE

MAGISTRATE JUDGE

**COMPLAINT**

---

Plaintiff, Shenzhen Mengdan Technology Co., Ltd (“Mengdan” or “Plaintiff”), for its  
Complaint against Defendant, RVLock & Co., LLC (“RVLock” or “Defendant”), hereby alleges as  
follows.

### **NATURE OF THE ACTION**

1. This is an action for declaratory judgment arising under the Declaratory Judgment Act, 28 U.S.C. §§ 2201-02, and the Patent Laws of the United States, 35 U.S.C. § 100 et seq., and for such other relief as the Court deems just and proper.
2. Plaintiff seeks a declaratory judgment of non-infringement of the Patent-in-Suit.
3. Plaintiff also seeks a declaratory judgment of invalidity of the Patent-in-Suit.

### **THE PARTIES**

4. Plaintiff Shenzhen Mengdan Technology Co., Ltd is a limited liability company organized and existing under the laws of the People's Republic of China, having its principal place of business at 307 #6 Phase 3, Fu Tong Cheng, Xixiang Ave. Fu Zhong Fu Community, Xixiang St. Baoan, Shenzhen, Guangdong, China 518000.
5. Defendant RVLock & Co., LLC ("RVLock" or "Defendant") is a limited liability company organized and existing under the laws of the State of Utah, with its principal place of business at 1770 West 2690 South Wellsville, UT 84339. RVLock's registered agent is Cade Harris, with an address at 5572 W 3050 S, Wellsville, UT 84339.

### **JURISDICTION AND VENUE**

6. This Court has exclusive subject matter jurisdiction pursuant to 28 U.S.C. §§ 1331, 1338(a), 2201, and 2202, and the Patent Laws of the United States, 35 U.S.C. § 1 *et. seq.*
7. Venue is proper in this judicial district pursuant to 28 U.S.C. § 1391.
8. This Court has personal jurisdiction over Defendant based at least upon Defendant's organization as a limited liability company under the laws of the State of Utah.
9. This Court has subject matter jurisdiction over this action based on a real and immediate controversy between Plaintiff and Defendant regarding whether Plaintiff's product infringes a certain patent alleged by Defendant, and further whether that patent is invalid.

## FACTUAL BACKGROUND

10. U.S. Patent No. 9,085,919 (“the ‘919 Patent”) is entitled “Touch Pad Lock Assembly,” and bears an issuance date of July 21, 2015. The ‘919 Patent bears a filing date of March 20, 2012. The ‘919 Patent lists Bruce C. Bacon as its inventor and Bauer Products, Inc. as the sole assignee. On information and belief, the ‘919 Patent is currently assigned to RVLock & Co., LLC. A true and correct copy of the ‘919 Patent is attached hereto as Exhibit A.

11. On March 15, 2024, Plaintiff received a letter from Workman Nydegger, informing Plaintiff that Defendant had retained Workman Nydegger to represent Defendant against Plaintiff.

12. The letter asserts Plaintiff’s “unlawful use of patented technology owned by RVLock [is] in violation of the laws of the United States.” This letter identifies as accused products Plaintiff ONNAIS RV Door Lock.

13. The letter further asserts that Plaintiff infringes at least Claim 1 of the ‘919 Patent through at least its use, importation, offers to sell, and/or sale of the Accused Products under 35 U.S.C. §271.” The letter is not designated confidential and is attached hereto as Exhibit B.

14. The March 15, 2023 letter included the following image and links to websites where Plaintiff’s products are available for sale.



ONNAIS RV Door Lock

<https://www.amazon.com/ONNAIS-Replacement-Password-Control%EF%BC%8CRV-Versatile/dp/B0CBP7LD9D>

<https://onnaisafe.com/products/onnais-rv-door-lock-versatile-rv-door-lock-keyless-entry-free-shipping>

15. Defendant has clearly stated its intention to initiate an Amazon Patent Evaluation Express (“APEX”) action against Plaintiff’s products on Amazon.

16. Upon information and belief, Defendant claims it will pursue APEX action to halt the sale of Plaintiff’s products on Amazon.

**COUNT I**  
**(Declaratory Judgment of Non-Infringement of the ‘919 Patent)**

17. Plaintiff incorporates by reference the allegations set forth above in this Complaint as if fully set forth herein.

18. An actual and justiciable controversy exists between Plaintiff and Defendant concerning the non-infringement of the ‘919 Patent.

19. Plaintiff's product has not infringed and does not infringe, directly or indirectly, any valid and enforceable claim of the '919 Patent, either literally or under the doctrine of equivalents.

20. Claims 1, 25, and 26 are the only independent claims of the '919 Patent. Each of these claims requires a "first link operably connected with the lock cam crank arm."

21. Plaintiff's product does not have a "first link operably connected with the lock cam crank arm," as shown in the photograph below.

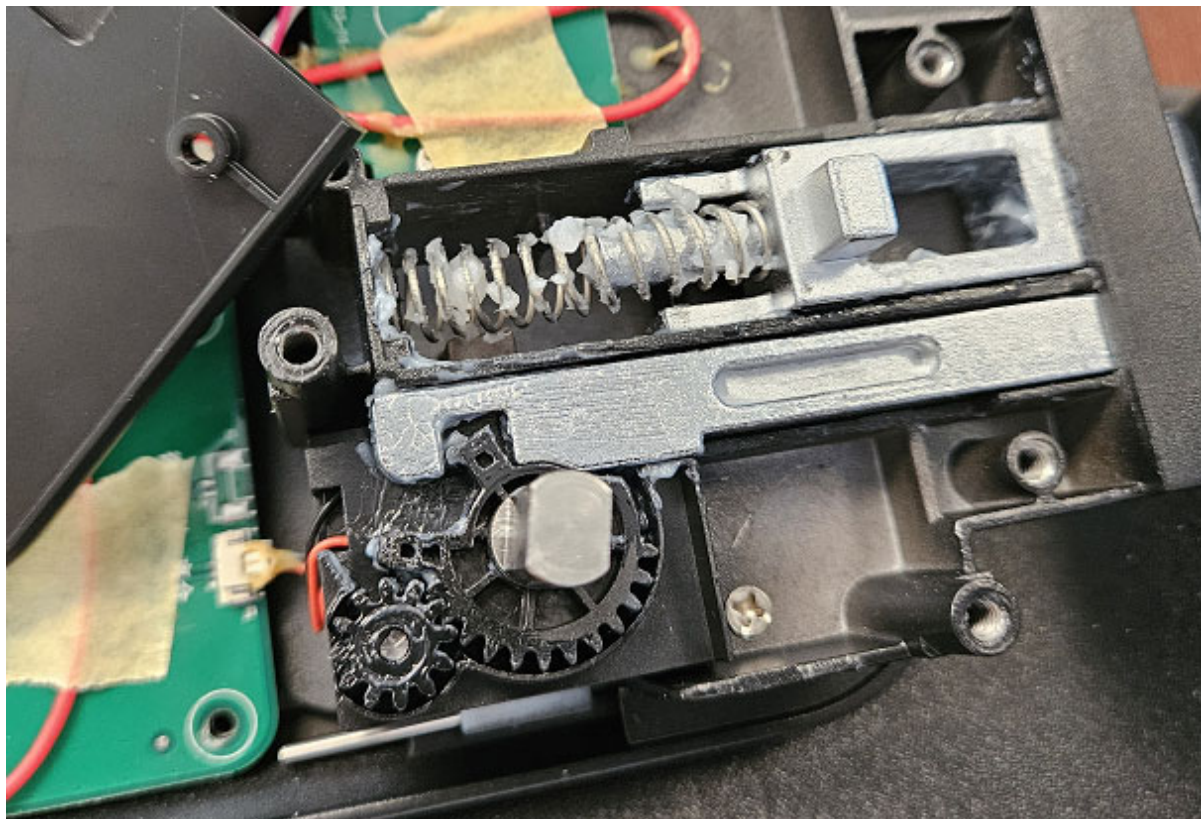

22. For at least the above reason, Plaintiff's product does not infringe any claims of the '919 Patent, either literally or under the doctrine of equivalents.

23. Plaintiff is entitled to a judgment from this Court that Plaintiff has not infringed, and does not infringe, any valid and enforceable claim of the '919 Patent.

**COUNT II**  
**(Declaratory Judgment of Invalidity of the '919 Patent)**

24. Plaintiff incorporates by reference the allegations set forth above in this Complaint as if fully set forth herein.

25. The '919 Patent is invalid for failure to meet the conditions of patentability and/or otherwise comply with one or more of 35 U.S.C. §§ 102, and 103.

26. The '919 Patent is invalid as anticipated and/or obvious under 35 U.S.C. § 102, 103 because the prior art discloses and/or renders obvious to one of ordinary skill in the art the limitations of the claims of the '919 Patent, at least as those claims are being asserted by Defendant.

27. The following prior art references anticipate or render obvious the claims of the '919 Patent.

Patent No.	Publication Date	Representative Image
US20100154489A1	2010-06-24	

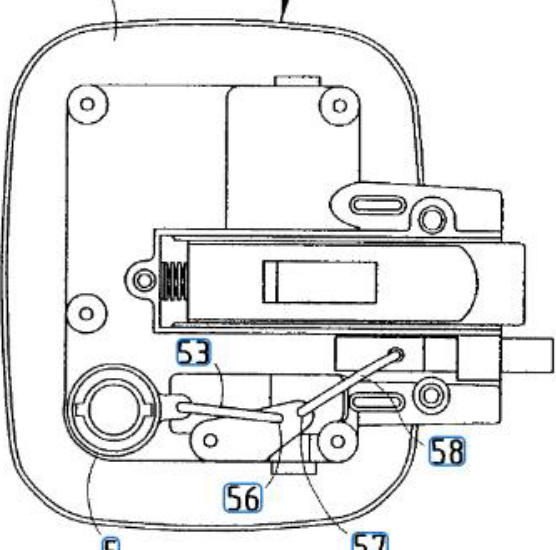
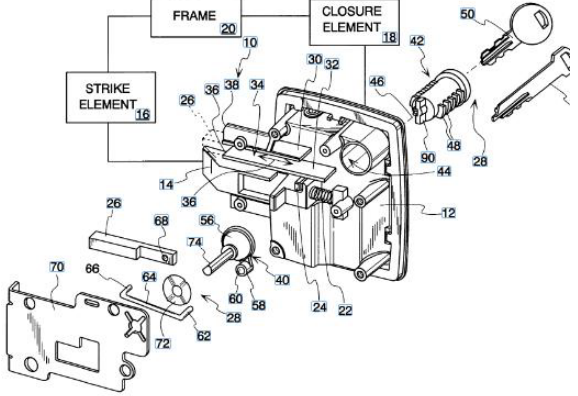
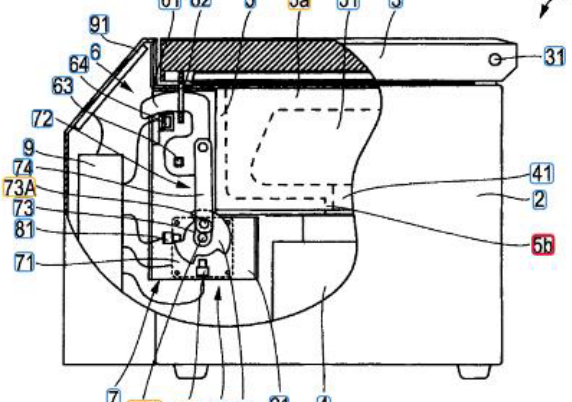
Patent No.	Publication Date	Representative Image
US6701761B1	2004-03-09	 <p>An exploded view diagram of a mechanical assembly. A central rectangular component is shown with a circular element on its left side. Below it, a lever-like mechanism is depicted. Callout numbers 53, 56, 57, and 58 are placed near various parts of the assembly.</p>
US6604393B2	2003-01-16	 <p>An exploded view diagram of a lock mechanism. Key components are labeled: FRAME 20, STRIKE ELEMENT 16, and CLOSURE ELEMENT 18. Numerous other parts are numbered, including 10, 12, 14, 16, 22, 24, 26, 28, 30, 32, 34, 36, 38, 40, 42, 44, 46, 48, 50, 52, 54, 56, 58, 60, 62, 64, 66, 68, 70, 72, 74, 76, 78, 80, 82, 84, 86, 88, 90, and 92. A key is shown to the right of the main assembly.</p>
US7874972B2	2008-09-11	 <p>A cross-sectional diagram of a mechanical assembly. The diagram shows internal components and their interaction. Callout numbers include 61, 62, 6, 5a, 51, 3, 7, 71A, 82, 8, 83, 21, 4, 31, 41, 2, and 5b. The diagram illustrates the internal structure of a housing or frame.</p>

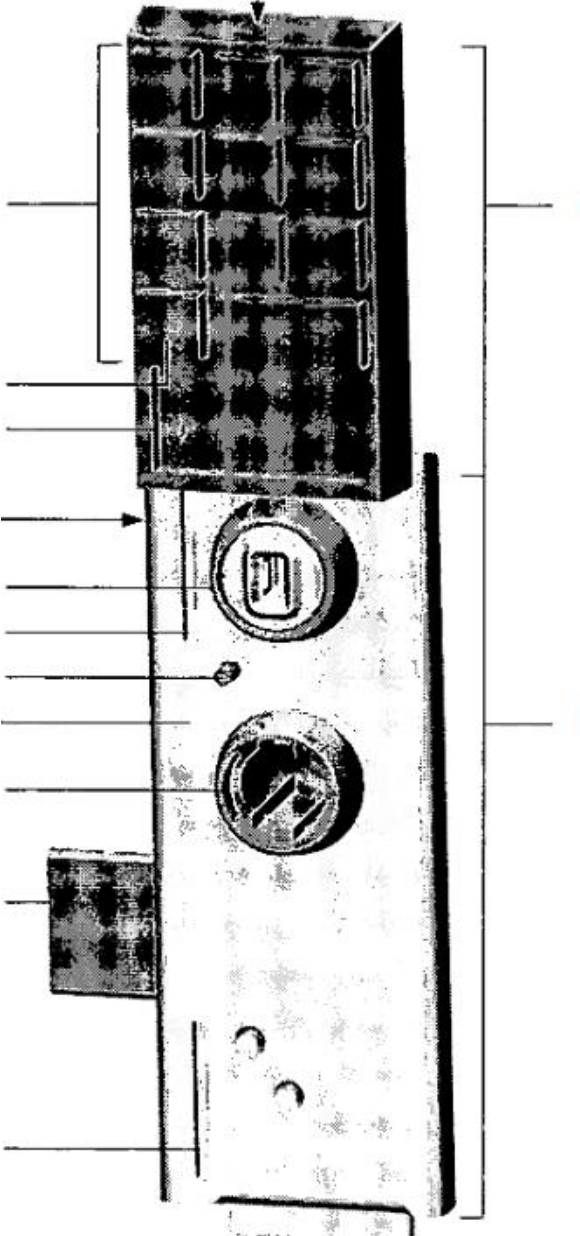

Patent No.	Publication Date	Representative Image
US20050179517A1	2005-08-18	 A technical drawing of a vertical mechanical assembly. The assembly consists of a top rectangular section with a grid of six rectangular openings, a middle section with two circular openings, and a bottom section with a small rectangular protrusion and two small circular features. Numerous horizontal and vertical lines with arrows point to various parts of the assembly, indicating specific components or features. The drawing is rendered in a high-contrast, black-and-white style.

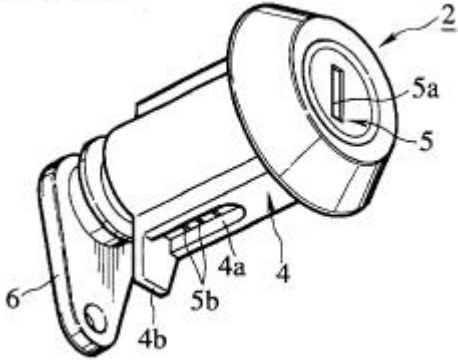
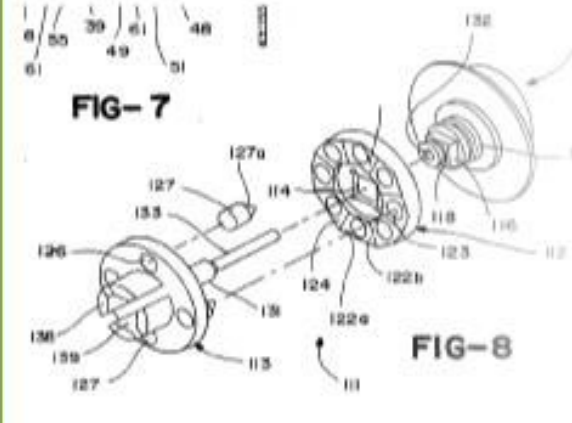
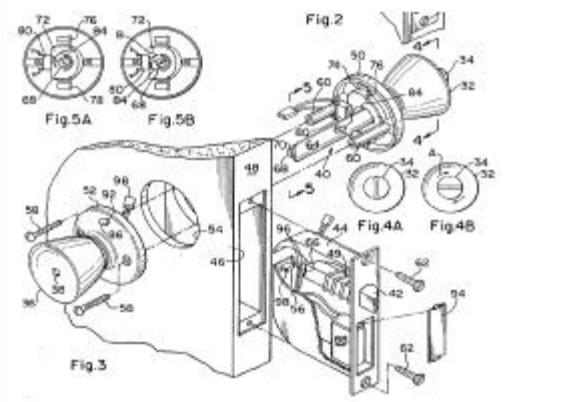

Patent No.	Publication Date	Representative Image
US20040040353A1	2004-03-04	
US20050044908A1	2005-03-03	
US7236085B1	2007-06-26	

Patent No.	Publication Date	Representative Image
US5697238A	1997-12-16	<p>PRIOR ART</p> 
US4967305A	1990-10-30	
US4683741A	1987-08-04	

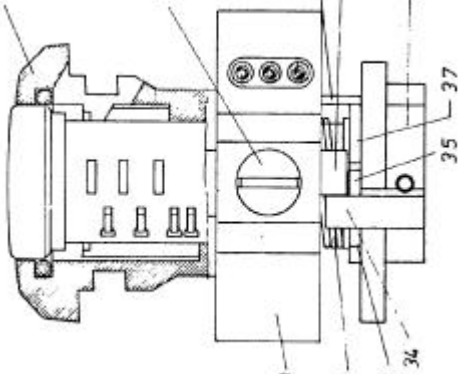
Patent No.	Publication Date	Representative Image
DE2629332A1	1978-01-12	

28. To resolve the legal and factual questions raised by Defendant and to afford relief from the uncertainty and controversy that Defendant's allegations have created, Plaintiff is entitled to a declaratory judgment that the '919 Patent is invalid.

### PRAYER FOR RELIEF

WHEREFORE, Plaintiff prays for judgment against Defendant as follows:

1. A declaration that Plaintiff has not infringed, and does not infringe, either directly or indirectly, any valid and enforceable claim of the '919 Patent, either literally or under the doctrine of equivalents;
2. A declaration that the claims of the Patents-in-Suit are invalid for failure to comply with the requirements of Title 35, United States Code, including at least §§ 102, and 103;
3. An injunction against Defendant and its officers, agents, servants, employees, and those persons in active concert or participation with them who receive actual notice of this judgment from directly or indirectly asserting infringement or instituting any action, in any Court or to any on-line marketplaces, for infringement of the '919 Patent against Plaintiff or any of its customers or suppliers;
4. A declaration that this action is an exceptional case under 35 U.S.C. § 285, with an award to Plaintiff of its attorneys' fees incurred in filing and prosecuting this action; and

5. Such other and further relief as this Court may deem just and proper under the circumstances.

DATED April 22, 2024.

PCFB LLC

/s/ Gregory D. Phillips

Gregory D. Phillips

OF COUNSEL

Ruoting Men, Esq.  
(To be admitted *pro hac vice*)  
GLACIER LAW LLP  
41 Madison Ave., Suite 2529  
New York, NY 10010  
T: (312) 270-0413  
F: (312) 801-4587  
[Ruoting.men@glacier.law](mailto:Ruoting.men@glacier.law)

Attorney for Plaintiff