

**IN THE UNITED STATES DISTRICT COURT
FOR THE EASTERN DISTRICT OF TEXAS
MARSHALL DIVISION**

DYSON, INC. and DYSON TECHNOLOGY
LIMITED,

Plaintiffs,

v.

SHARKNINJA, INC.,
OMACHRON ALPHA INC., and
OMACHRON INTELLECTUAL PROPERTY
INC.,

Defendants.

Case No. 2:24-cv-386

JURY TRIAL DEMANDED

COMPLAINT FOR PATENT INFRINGEMENT

Plaintiffs Dyson, Inc. and Dyson Technology Limited (collectively, “Dyson”) files this Complaint seeking relief for patent infringement by SharkNinja, Inc. (“SharkNinja”), Omachron Alpha Inc. (“Omachron Alpha”), and Omachron Intellectual Property Inc. (“Omachron IP”) (collectively, “Defendants”). Omachron Alpha and Omachron IP are hereinafter collectively referred to as Omachron. Dyson states and alleges the following:

PRELIMINARY STATEMENT

1. Dyson has been a leader in the field of vacuum cleaners and floorcare solutions since it was founded in the United Kingdom in 1991. Dyson manufactures and sells patented household vacuum cleaners that use cyclonic separation technology to spin dust and dirt out of the air at incredibly high speeds, leaving the airflow unobstructed and allowing the vacuums to maintain a constant level of suction. Vacuums sold under the Dyson brand are known internationally for their patented technology and engineering, and outstanding cleaning performance. As a result of its 30+ years of innovation, Dyson has a leading portfolio of patented floorcare solutions covering all aspects of its industry leading vacuums.

2. Prior to Dyson’s founding, conventional vacuum cleaners worldwide were essentially suction-type machines that used a bag in the cleaner to trap dust and dirt. Dust quickly filled the pores of the bag and blocked the airflow, causing the vacuum to lose suction. To solve the loss of suction associated with traditional vacuums, Dyson developed a bagless vacuum that used cyclonic technology to separate dirt and debris from the vacuum’s incoming air flow without diminishing suction.

3. Since its founding, Dyson’s patented innovations have repeatedly redefined the consumer market for cyclonic vacuum cleaners. In the early 1990s, Dyson perfected its first Dual Cyclone technology bagless vacuum cleaner. The new machine used an outer cyclone to remove large debris and dirt, while an inner cyclone created an intense centrifugal force to spin the finer

dust particles out of the air. Dust and dirt particles were deposited into the vacuum's clear collection bin, eliminating the need for conventional and under-performing vacuum bags.

4. In the early 2000s, Dyson developed an entirely new type of cyclone system, Root Cyclone technology, which had even greater cleaning efficiency. Dyson discovered that spreading the air flow through many cyclones made it possible to pick up even finer dirt and debris from the cleaning surface without loss of suction.

5. In 2006, Dyson launched the first handheld cyclonic vacuum, the DC16. The DC16's patented technology combined the sophisticated cleaning efficiency of Dyson's Root Cyclone with an all-new handheld design that made it portable, ergonomic, and easy to use and maintain.



Dyson DC16.

6. In the years that followed, Dyson pioneered its patented line of cyclonic stick vacuums, which combined the portability of its patented handheld vacuums with the reach and versatility of a floor vacuum:



Dyson DC35 (left) and V8 (right).

7. More recently, Dyson again redefined the cyclonic vacuum market with the release of its patented V10 vacuum, with 20% more suction power than the Dyson V8 and up to 60 minutes of fade-free power.¹



Dyson V10.



¹ Actual run time will vary based on power mode and/or attachments used.

8. Dyson’s substantial investments of resources and time have culminated in the granting of hundreds of patents in the United States and worldwide to Dyson. Dyson’s innovations were well known, and SharkNinja and Omachron knew Dyson’s floorcare solutions were patented, but chose to incorporate Dyson’s patented technology into SharkNinja’s products anyway.

9. SharkNinja and Omachron work together to make lower-quality imitations of Dyson’s patented products. Before Defendants started copying Dyson’s patented designs, SharkNinja’s vacuums looked very different than they do today, for example, as shown below:

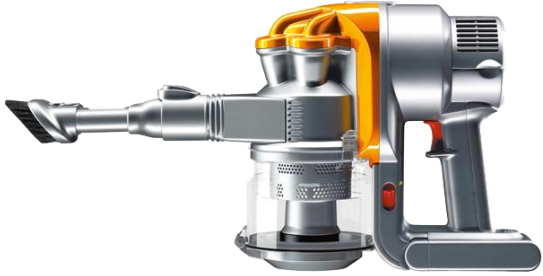

10. By producing lower-quality imitations of Dyson’s patented products, Defendants can invest less in research and development and sell SharkNinja’s products at lower prices. Below are a just a few examples of the striking similarities between Dyson’s patented products and Defendants’ later-released imitations:

Dyson DC16	Shark Rocket
 A silver and orange Dyson DC16 handheld stick vacuum with a long, angled motor head and a clear dust bin.	 A blue and silver Shark Rocket handheld stick vacuum with a similar angled motor head and a clear dust bin.

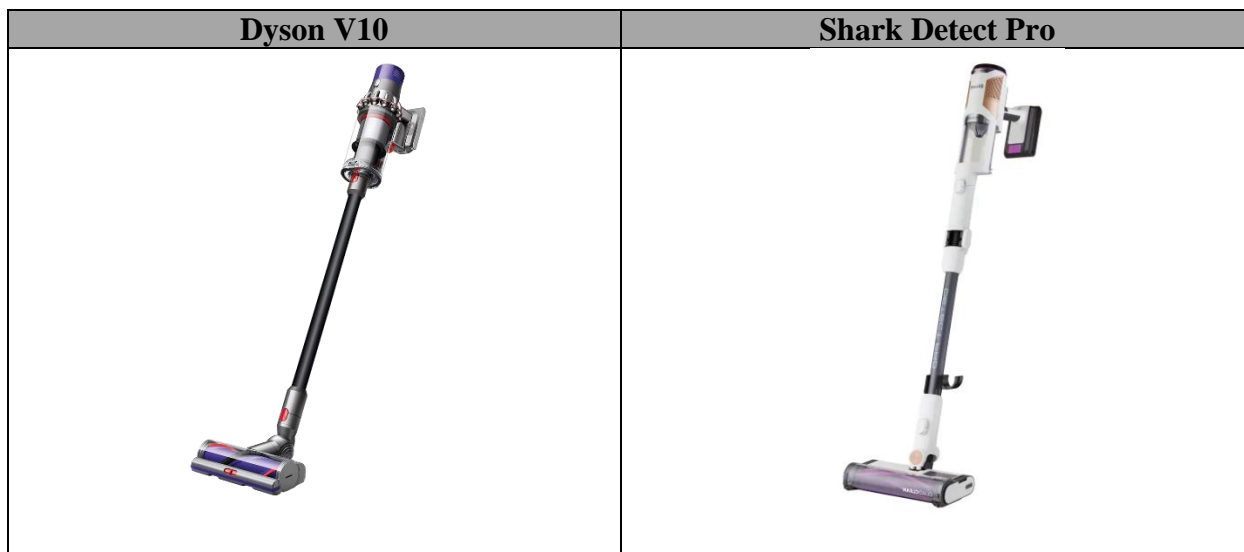

11. The resemblance between Defendants' products and Dyson's patented products is undeniable. Nor is it accidental. In its 2023 Annual Report, SharkNinja boasted that its cheaper imitations have allowed it to take market share from Dyson:

Most of our competitors typically sell at a lower price point with some exceptions, such as Dyson....We have succeeded in the marketplace by capitalizing on the sale of product offerings situated in the mid-price range, taking market share from competitors who sell products at price points above and below our own. Shark competes with brands including Dyson...."

Ex. 11 at 58.²

12. As a result of Defendants continuing and willful conduct, Dyson now finds itself competing for the same customers against the very technology it invented and patented.

13. Dyson brings this lawsuit to protect its intellectual property investments and to hold Defendants accountable for their willful infringement. Defendants' actions have caused harm to

² Documents attached to the end of SharkNinja's 2023 Annual Report have been omitted from Exhibit 11 for brevity. The entirety of SharkNinja's 2023 Annual Report is available at https://ir.sharkninja.com/files/doc_financials/2023/ar/SN-2023-Annual-Report-Final.pdf.

Dyson, as alleged below, by incorporating Dyson's patented technologies into Defendants' products. Defendants' actions also significantly harm innovation and undermine the intent of the U.S. patent laws. If Defendants' improper copying and use of Dyson's technologies allows it to avoid what is needed to develop new products, other companies will be encouraged to simply copy others' proprietary technologies rather than hire engineers, invest in innovation, and develop new technologies organically. Dyson therefore also seeks injunctive relief to stop Defendants' improper infringement of Dyson's lawful patent rights.

NATURE OF THE ACTION

14. This is an action under the Patent Laws of the United States, 35 U.S.C. §§ 1, *et seq.*, for infringement by Defendants of one or more claims of U.S. Patent Nos. 8,302,250; 8,117,712; 7,603,745; 8,444,731; and 8,100,999 (collectively referred to as the "Patents-in-Suit").

THE PARTIES

15. Dyson, Inc. is a corporation organized and existing under the laws of the State of Illinois, having its principal place of business at 1330 W. Fulton Street, 5th Floor, Chicago, Illinois, 60607.

16. Dyson Technology Limited is a private limited company organized and existing under the laws of England and Wales, having its principal place of business at Tetbury Hill, Malmesbury SN16 0RP, United Kingdom.

17. On information and belief, SharkNinja Inc. is a corporation organized under the laws of the Cayman Islands, located at PO Box 309, Uglan House, Grand Cayman, KY1-1104, Cayman Islands.

18. On information and belief, Omachron Alpha Inc. is an Ontario company, having a principal place of business at 9 King Lane, P.O. Box 130, Hampton, Ontario, L0B 1J0, Canada.

19. On information and belief, Omachron Intellectual Property Inc. is an Ontario company, having a principal place of business at 9 King Lane, P.O. Box 130, Hampton, Ontario, LOB IJO, Canada.

JURISDICTION AND VENUE

20. This Court has subject matter jurisdiction over this action pursuant to 28 U.S.C. §§ 1331 and 1338(a).

21. This Court has personal jurisdiction over Defendants. On information and belief, Defendants have conducted and are conducting substantial business in the State of Texas and this District, both generally and with respect to the allegations in this Complaint. Further, on information and belief, Defendants have committed and continue to commit acts of patent infringement in the State of Texas and this District giving rise to Dyson's infringement claims, including making, having made, using, selling, and/or offering to sell in the State of Texas and this District, and/or importing into the State of Texas and this District the accused products, either directly or through at least one of their wholly owned subsidiaries or agents, and/or inducing others to commit acts of patent infringement in the State of Texas and this District.

22. SharkNinja sells and/or offers to sell the accused products to consumers in the State of Texas and this District directly and through the stream of commerce by working with its wholly owned subsidiaries or agents, distributors, and/or other entities located in the State of Texas. In its 2023 Annual Report, SharkNinja touted that "[w]e sell our products using an omnichannel distribution strategy that consists primarily of retail and DTC [direct-to-consumers] channels. Our retail channel covers brick-and-mortar retailers, e-commerce platforms and multichannel retailers, which, in turn, sell our products to the end consumers...Our DTC channel covers sales directly to consumers through our websites." Ex. 11 at 63.

23. On information and belief, SharkNinja executes its “DTC channel” sales strategy by selling the accused products directly to consumers in the State of Texas and this District using SharkNinja’s websites at <https://sharkninja.com> and www.sharkclean.com. For example, SharkNinja’s website, <https://sharkninja.com/>, directs consumers to “Shop Our Brands,” which takes consumers to <https://sharkninja.com/shopnow/>, a screen capture of which is provided below. This page similarly encourages consumers to “Explore & Shop,” and by selecting the American flag button, consumers are directed to www.sharkclean.com where they can purchase the accused products.

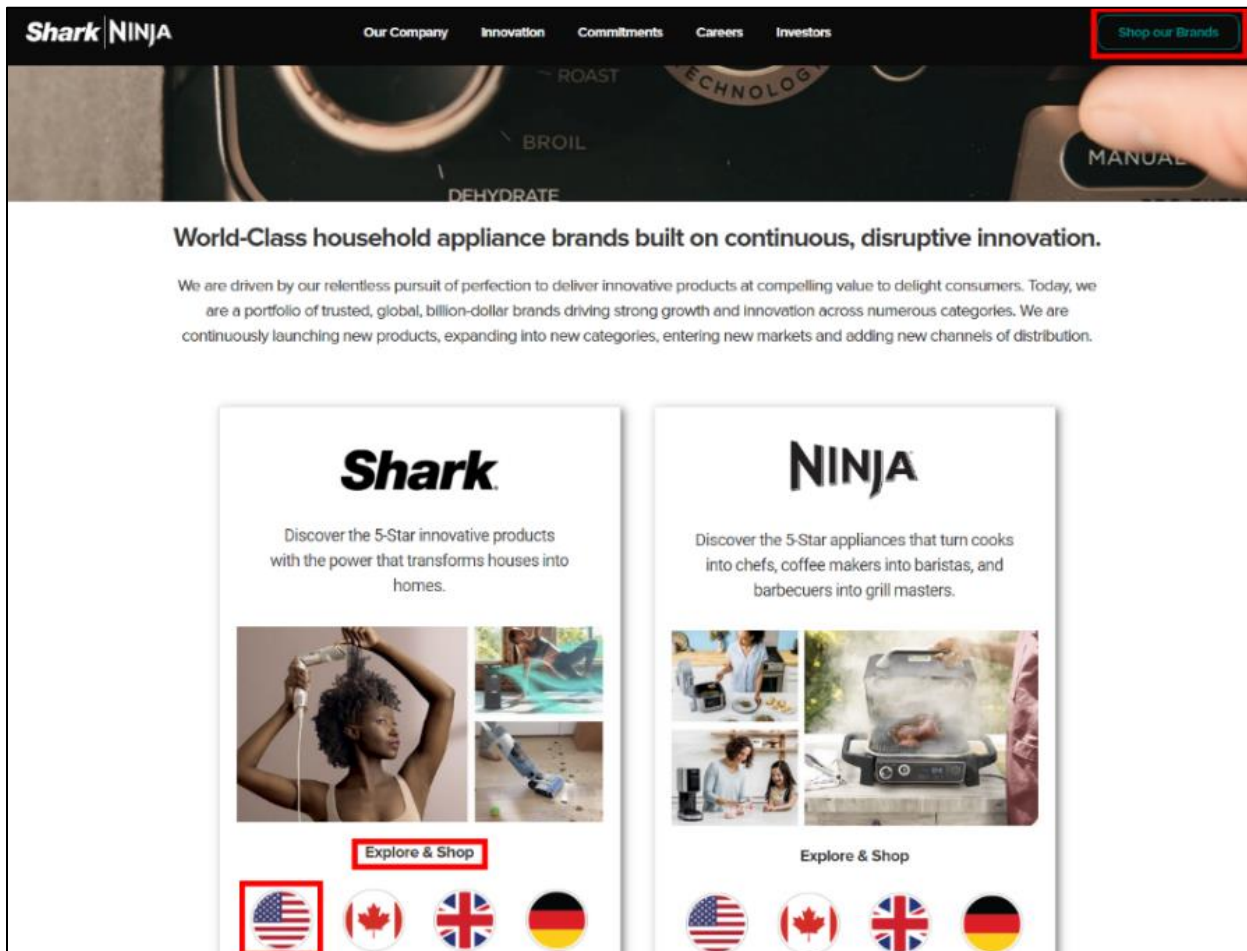

Explore our Brands, <https://sharkninja.com/shopnow/> (last accessed May 23, 2024) (annotated).

24. On information and belief, the accused products are purchased by and delivered to consumers in the State of Texas and this District by placing orders on www.sharkclean.com. *See, e.g.,* <https://www.sharkclean.com/products/shark-detect-pro-cordless-stick-vacuum-with-quadclean-multi-surface-brushroll-zidIW1111>. For example, the screen capture below from www.sharkclean.com shows the accused Vertex Pro vacuum available for purchase and delivery to consumers in the State of Texas and this District:

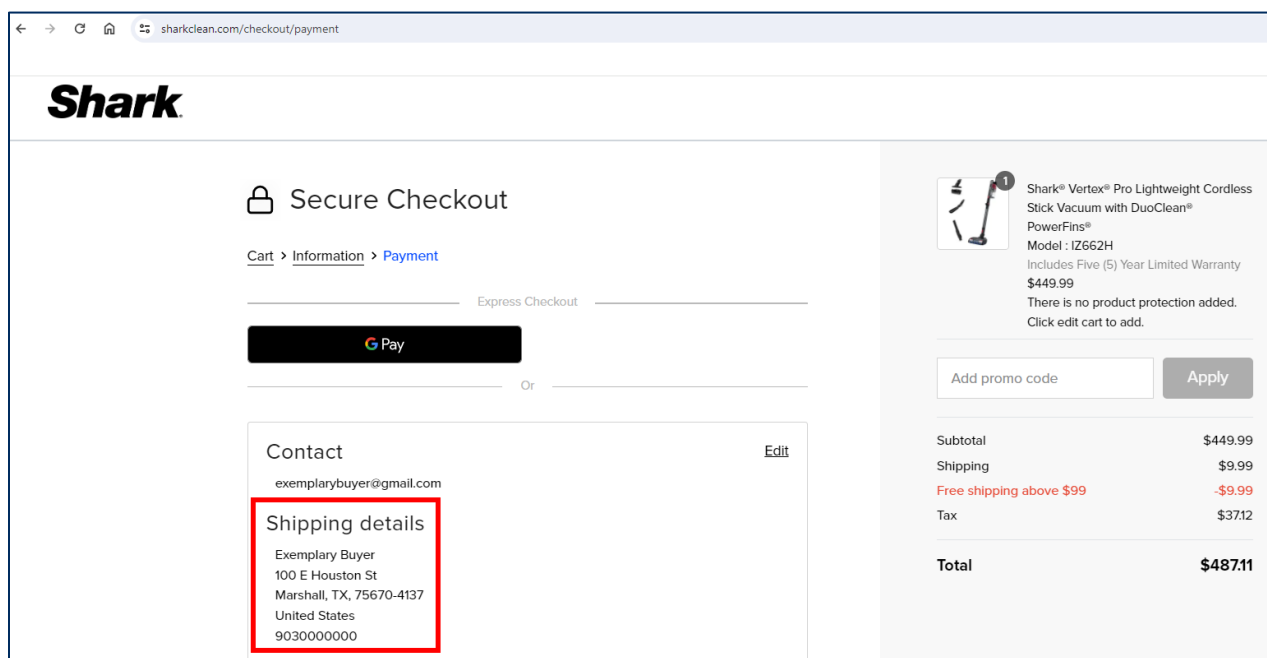

Secure Checkout, <https://www.sharkclean.com/checkout/payment> (last accessed May 23, 2024), with product selected from *Shark® Vertex® Pro Lightweight Cordless Stick Vacuum with DuoClean® PowerFins®*, <https://www.sharkclean.com/products/shark-vertex-pro-lightweight-cordless-stick-vacuum-with-duoclean-powerfins-zidIZ662H> (last accessed May 23, 2024) (annotated).

25. On information and belief, SharkNinja executes its “retail channel” sales strategy by selling the accused products through retailers with stores in the State of Texas and this District. For example, on information and belief, consumers can purchase SharkNinja’s accused products online or in person from retailers in the State of Texas and this District, and likewise pick up SharkNinja’s accused products in person from those retailers in the State of Texas and in this

District. In its 2023 Annual Report, SharkNinja explained that “[s]ome of the largest retailers we sell to include Walmart, Amazon, Costco, Target and Best Buy, as well as a significant number of independent retailers.” Ex. 11 at 63. It further touted that “we partnered with 42 retailers across the United States and over 140 retailers globally. Our largest retailers include Walmart, Amazon and Costco, each of which accounted for more than 10% of our net sales, and together made up 44.7% of our net sales for the year ended December 31, 2023.... We also participate in a strategic joint business plan with Target.” *Id.* at 68.

26. As one example of SharkNinja’s “retail channel” sales in the State of Texas and this District, the accused products can be purchased and picked up in person from Walmart in Marshall, TX at 1701 E End Blvd N, Marshall, TX 75670. See <https://www.walmart.com/store/918-marshall-tx>. For example, the accused Pet Cordless is available for same day pick-up at the Walmart in Marshall:

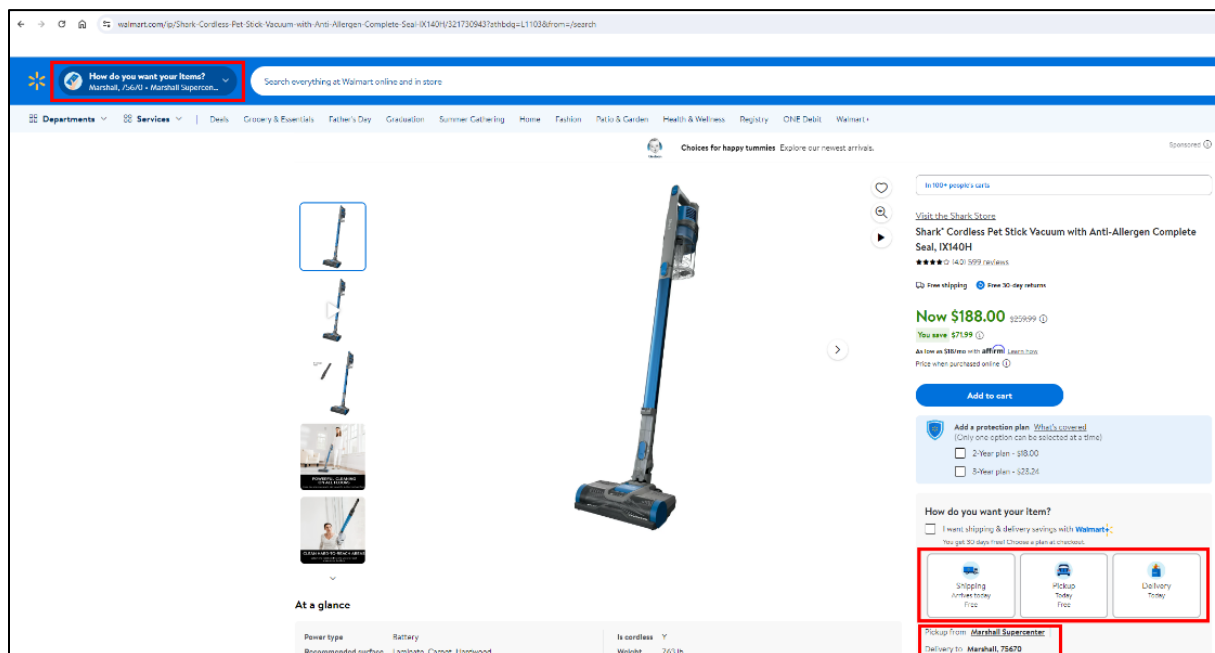

Shark® Cordless Pet Stick Vacuum with Anti-Allergen Complete Seal, IX140H, <https://www.walmart.com/ip/Shark-Cordless-Pet-Stick-Vacuum-with-Anti-Allergen-Complete-Seal-IX140H/321730943?athbdg=L1103&from=/search> (last accessed May 23, 2024)

(annotated).

27. Therefore, SharkNinja has purposefully and voluntarily placed one or more infringing products into the stream of commerce with the expectation that they will be purchased and/or used by residents of the State of Texas and this District and/or incorporated into downstream products purchased by consumers in the State of Texas and this District, including by directly or indirectly working with its wholly-owned subsidiaries or agents, distributors, and other entities located in the State of Texas to ensure their products reach the State of Texas and this District.

28. On information and belief, SharkNinja derives substantial revenue from goods and services it provides to residents of the State of Texas and this District, including revenue associated with the accused products. In its 2023 Annual Report, SharkNinja told shareholders “[w]e generate net sales from product sales to retailers, both brick-and-mortar and online, as well as through DTC sales and distributors. We recognize sales upon transfer of control of products to retailers, consumers and distributors...” Ex. 11 at 63. SharkNinja reported that it derived \$1,819,465,000 from 2023 sales of “Cleaning Appliances,” “which includes corded and cordless vacuums,” including the vacuums that infringe the Patents-in-Suit. *Id.* at 63, 67.

29. On information and belief, SharkNinja’s wholly owned subsidiary, SharkNinja Sales Company, is listed as a Taxable Entity in the State of Texas and pays sales tax for sales made to residents of the State of Texas. According to public filings, SharkNinja has the same officers as SharkNinja Sales Company, including at least Mark Barrocas, Lawrence Flynn, and Pedro J. Lopez-Baldrich.

30. SharkNinja, which is publicly traded on the New York Stock Exchange, likewise promotes the accused products on its investor relations website, <https://ir.sharkninja.com/overview/default.aspx>, both in promotional videos and investor presentations. For example, a video displayed prominently at

<https://ir.sharkninja.com/overview/default.aspx> advertises the accused Stratos Cordless, Detect Pro, and Wandvac vacuum cleaners:

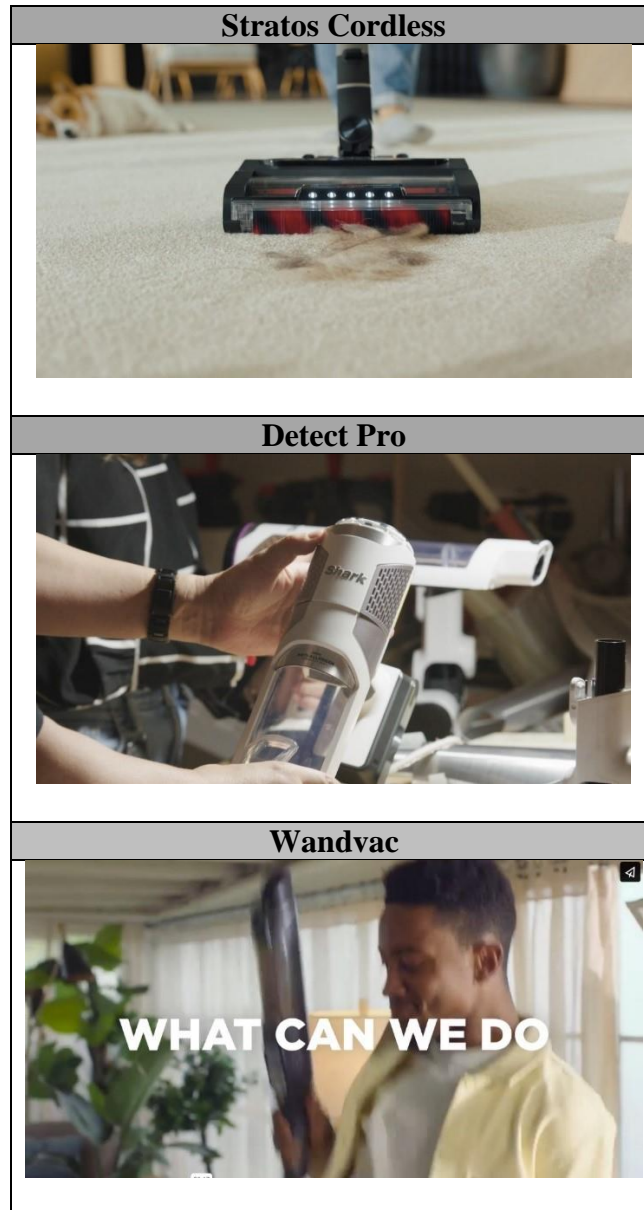

Overview, <https://ir.sharkninja.com/overview/default.aspx> (last accessed May 23, 2024).

31. Similarly, SharkNinja markets the accused products in its presentations to investors, as shown below in its March 6, 2024 and March 28, 2024 presentations. For example, SharkNinja's March 6, 2024 presentation to investors advertises the accused Stratos Cordless, Pet Cordless, and Wandvac vacuum cleaners, as shown below:



SharkNinja Investor Presentation March 2024, available at https://ir.sharkninja.com/files/doc_presentation/2024/03/06/SharkNinja-Investor-Presentation-March-2024-v-FF2.pdf (last accessed May 23, 2024) (annotated).

32. Similarly, SharkNinja's March 28, 2024 presentation to investors advertises the accused Detect Pro vacuum cleaner, as shown below:

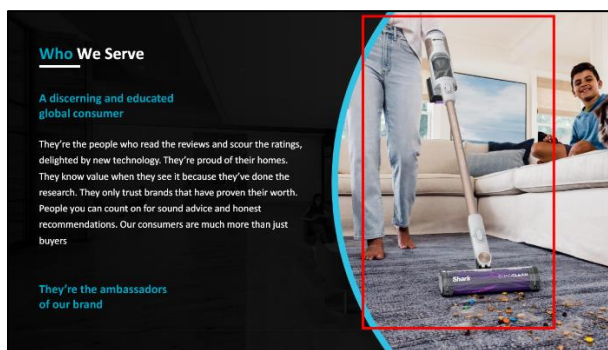

SharkNinja Investor Presentation March 2024, available at https://ir.sharkninja.com/files/doc_presentations/2024/Mar/28/sharkninja-investor-presentation-vf-3-28-24.pdf (last accessed May 23, 2024) (annotated).

33. SharkNinja's websites, <https://sharkninja.com/>, <https://ir.sharkninja.com/overview/default.aspx>, and www.sharkclean.com are highly interactive and commercial websites accessible to residents of the State of Texas and this District, through

which SharkNinja promotes and sells its products and services, including the products that infringe the asserted patents, as demonstrated above.

34. Through the forgoing activities, SharkNinja has purposefully availed itself of the privilege of conducting activities within the State of Texas, thus invoking the benefits and protections of its laws. SharkNinja has sufficient minimum contacts with the State of Texas such that it is subject to specific personal jurisdiction for the matters alleged in this Complaint. Further, the exercise of personal jurisdiction based on these repeated and highly-pertinent contacts does not offend traditional notions of fairness and substantial justice.

35. Alternatively, SharkNinja is subject to jurisdiction in the United States, and specifically in the State of Texas, pursuant to Fed. R. Civ. P. 4(k)(2). On information and belief, SharkNinja has contacts with the United States that include at least making, using, offering to sell, and/or selling the accused products throughout the United States, including the State of Texas and this District. For example, in its 2023 Annual Report, SharkNinja stated that “[w]e have a dynamic, in-house global product design team located across the United States...” Ex. 11 at 61. SharkNinja also told shareholders that “[w]e have developed a presence adjacent to many of our major retailers and growth regions, in Bentonville [and] Minneapolis...in order to be in close contact with our key retailers.” *Id.* at 68.

36. This Court also has personal jurisdiction over Omachron Alpha and Omachron IP. SharkNinja and Omachron have publicly stated that SharkNinja and Omachron jointly co-develop SharkNinja’s vacuums, including through “a joint effort between Omachron and SharkNinja,” and “are tightly bound partners in product development” who collaborate “on a nearly-daily basis:”

For over a decade, the development of SharkNinja’s vacuums has been—and continues to be—a joint effort between Omachron and SharkNinja. Mr. Conrad and Mr. Peterson have traveled to SharkNinja’s Needham headquarters to collaborate with SharkNinja engineers and product developers about four to six times a year

for day-long meetings. The SharkNinja and Omachron teams brainstorm, evaluate, and review prototypes, images and drawings of new designs together. In addition to the frequent in-person collaboration between SharkNinja and Omachron in Needham, SharkNinja's Needham-based engineers collaborate closely with Omachron over phone and video, often on a near-daily basis during periods of product development. SharkNinja is not merely a passive licensee...SharkNinja and Omachron are tightly bound partners in product development....

SharkNinja Operating LLC v. Dyson, Inc., No. 1:23-cv-11277 (D. Mass), Dkt. 57 at 6-7 (internal citations omitted).

37. SharkNinja and Omachron have also publicly stated that “Omachron employs numerous personnel...including Wayne Conrad, David Peterson, and Nicole Murphy [who] have been instrumental in developing SharkNinja vacuum products.” *Id.* at 6.

38. SharkNinja and Omachron have elaborated on their collaboration in other proceedings, publicly stating that the “partnership between SharkNinja and Omachron spans decades” and that “Omachron and SharkNinja designs were incorporated into...the Shark Cordless Pro, Pet Cordless, Pet Plus Cordless, Pet Pro Cordless, Stratos Corded, Stratos Cordless, UltraLight Pet Corded, UltraLight Pet Pro Corded, Vertex Corded, Vertex Cordless, and Vertex Pro Cordless,” which, as set forth below, practice the inventions claimed in one or more patents asserted by Dyson here:

The partnership between SharkNinja and Omachron spans decades, and the companies have developed cutting edge technology used in over 150 consumer products around the world together.

...

Together, SharkNinja and Omachron have developed numerous corded and cordless vacuum designs.

...

The Omachron and SharkNinja designs were incorporated into multiple commercially successful SharkNinja vacuums, including but not limited to vacuums marketed as the Shark Cordless Pro, Pet Cordless, Pet Plus Cordless, Pet Pro Cordless, Stratos Corded, Stratos Cordless, UltraLight Pet Corded, UltraLight Pet Pro Corded, Vertex Corded, Vertex Cordless, and Vertex Pro Cordless.

...

SharkNinja and Omachron work closely together to develop Mr. Conrad's inventions into successful commercial products. For example, engineers at SharkNinja and Omachron interact throughout the development process, including Mr. Conrad and engineers from Omachron having calls with SharkNinja engineers in Boston and even making frequent trips to Boston to work with SharkNinja. Together, the engineers develop innovative designs, build and test prototypes, and resolve any technical issues to refine and finalize the designs.

...

Omachron and SharkNinja's designs were incorporated into multiple commercially successful SharkNinja vacuums, including but not limited to vacuums marketed as the Shark Cordless Pro, Pet Cordless, Pet Plus Cordless, Pet Pro Cordless, Stratos Corded, Stratos Cordless, UltraLight Pet Corded, UltraLight Pet Pro Corded, Vertex Corded, Vertex Cordless, and Vertex Pro Cordless, and these designs continue to be incorporated in products under development.

In the Matter of Certain Surface Cleaning Devices and Components Thereof, USITC Inv. No. 337-TA-3741 (U.S.I.T.C. April 23, 2024), SharkNinja and Omachron's Statement of Public Interest at 2 and Verified Complaint at ¶¶5, 6, 24, 26.

39. On information and belief, including the statements by Defendants provided above, Omachron works jointly with SharkNinja to develop and manufacture the accused products, knowing the accused products would be sold to consumers in the State of Texas and this District directly by SharkNinja or through the stream of commerce, as outlined above.

40. Through the forgoing activities, Omachron has purposefully availed itself of the privilege of conducting activities within the State of Texas, thus invoking the benefits and protections of its laws. Omachron has sufficient minimum contacts with the State of Texas such that it is subject to specific personal jurisdiction for the matters alleged in this Complaint. Further, the exercise of personal jurisdiction based on these repeated and highly-pertinent contacts does not offend traditional notions of fairness and substantial justice.

41. Alternatively, Omachron is subject to jurisdiction in the United States, and specifically in the State of Texas, pursuant to Fed. R. Civ. P. 4(k)(2). On information and belief,

Omachron has contacts with the United States that include at least making, using, offering to sell, and/or selling the accused products throughout the United States, including the State of Texas and this District. For example, as described above and as Defendants stated, Omachron employees travel to at least Massachusetts to co-develop the accused products, knowing those products would be sold throughout the United States, including the State of Texas and this District. Further, as described below, Omachron has applied for and received U.S. patents from the United States Patent and Trademark Office. Thus, Omachron has purposefully availed itself of the privilege of conducting activities within the United States and has invoked the benefits and protections of its laws.

42. Venue is proper as to SharkNinja, Inc.; Omachron Alpha Inc.; and Omachron Intellectual Property IP Inc. at least under 28 U.S.C. § 1391(c)(3) because they are foreign corporations or the agents of foreign corporations not residing in any United States Judicial District, which may be sued in any District.

PATENTS-IN-SUIT

43. U.S. Patent No. 8,302,250 (“’250 Patent”), titled “CLEANING APPLIANCE,” issued on November, 6, 2012. A true and correct copy of the ’250 Patent is attached as Exhibit 1. Dyson Technology Limited owns all rights, title, and interest in and to the ’250 Patent and has the right to sue and recover for past, present, and future infringement. Dyson, Inc. is the exclusive U.S. distributor of Dyson vacuum cleaners and parts in the United States.

44. U.S. Patent No. 8,117,712 (“’712 Patent”), titled “CLEANING APPLIANCE,” issued on February 21, 2012. A true and correct copy of the ’712 Patent is attached as Exhibit 2. Dyson Technology Limited owns all rights, title, and interest in and to the ’712 Patent and has the right to sue and recover for past, present, and future infringement. Dyson, Inc. is the exclusive U.S. distributor of Dyson vacuum cleaners and parts in the United States.

45. U.S. Patent No. 7,603,745 (“’745 Patent”), titled “CLEANER HEAD FOR A CLEANING APPLIANCE,” issued on October 20, 2009. A true and correct copy of the ’745 Patent is attached as Exhibit 3. Dyson Technology Limited owns all rights, title, and interest in and to the ’745 Patent and has the right to sue and recover for past, present, and future infringement. Dyson, Inc. is the exclusive U.S. distributor of Dyson vacuum cleaners and parts in the United States.

46. U.S. Patent No. 8,444,731 (“’731 Patent”), titled “HANDHELD CLEANING APPLIANCE,” issued on May 21, 2013. A true and correct copy of the ’731 Patent is attached as Exhibit 4. Dyson Technology Limited owns all rights, title, and interest in and to the ’731 Patent and has the right to sue and recover for past, present, and future infringement. Dyson, Inc. is the exclusive U.S. distributor of Dyson vacuum cleaners and parts in the United States.

47. U.S. Patent No. 8,100,999 (“’999 Patent”), titled “SEPARATING APPARATUS FOR A CLEANING APPLIANCE,” issued on January 24, 2012. A true and correct copy of the ’999 Patent is attached as Exhibit 5. Dyson Technology Limited owns all rights, title, and interest in and to the ’999 Patent and has the right to sue and recover for past, present, and future infringement. Dyson, Inc. is the exclusive U.S. distributor of Dyson vacuum cleaners and parts in the United States.

COUNT ONE: INFRINGEMENT OF U.S. PATENT NO. 8,302,250

48. Dyson restates and incorporates by reference the allegations made in Paragraphs 1 through 47 of the Complaint above.

49. Upon information and belief, Defendants have infringed, and will continue to infringe, one or more claims of the ’250 Patent under 35 U.S.C. § 271(a), either literally and/or under the doctrine of equivalents, by making, using, offering to sell, selling and/or importing into the United States certain vacuum cleaners, for example, at least the Detect Pro, Clean & Empty

Cordless Stick Vacuum, Rocket Pro DLX Corded Stick, and all other Shark vacuum cleaners with materially similar designs as the forgoing vacuum cleaners. These vacuum cleaners are hereinafter referred to as the '250 Accused Products.

50. Exhibit 6 includes a chart comparing claim 1 of the '250 Patent to an exemplary '250 Accused Product. As set forth in Exhibit 6, the '250 Accused Products practice, in whole or in material part, the technology claimed in the '250 Patent. Accordingly, the '250 Accused Products infringe at least claim 1 of the '250 Patent. The '250 Accused Products are non-limiting examples identified based on publicly available information, and Dyson reserves the right to identify additional infringing activities, products, and services on the basis of information obtained, for example, during discovery.

51. Upon information and belief, Defendants knew that Dyson had patents covering vacuums based on their conduct monitoring patents, including patents of their competitors such as Dyson, and investigating and assessing potential infringement of those patents. For example, the '250 Patent is identified on Dyson's Marking website: <https://www.dyson.com/inside-dyson/patents>; <https://www.dyson.com/content/dam/dyson/inside-dyson/patents/Product%20Marking%20Report%20US%20V2.pdf>. Through such activities, Defendants either learned of the '250 Patent or subjectively believed there was a high probability that Dyson has patents covering features of vacuum products but took deliberate actions to avoid learning of that fact and which features were patented.

52. Further, Defendants knew of the '250 Patent because its family member, European Patent No. 2,043,492, was asserted by Dyson against SharkNinja Europe Limited and SharkNinja Germany GmbH in the Unified Patent Court (UPC_CFI_443/2023).

53. Further, Defendants knew of the '250 Patent based on the patent prosecution activities of SharkNinja's wholly-owned subsidiary SharkNinja Operating, LLC. As one example, SharkNinja Operating, LLC's U.S. Patent No. 11,213,177 cites Dyson's U.S. Patent No. 8,387,204, a family member of the '250 Patent.

54. Further, Defendants knew of the '250 Patent because it is cited by the following U.S. patents assigned to Omachron IP: 9,301,666; 9,591,952; 9,826,868; 10,016,106; 10,258,210; 10,271,704; 10,299,643; 10,327,607; 10,405,709; 10,827,891; 11,246,462; 11,285,495; 11,690,489; 11,751,740; 11,751,733; 11,896,186; 11,910,984; 11,918,170; and 11,969,133.

55. Thus, Defendants' knowledge of and intention to infringe the '250 Patent is evidenced by Exhibit 6, which establishes the striking similarities between the '250 Patent and the '250 Accused Products. Despite knowing of the '250 Patent or being willfully blind to the '250 Patent, Defendants continued to make, use, sell, and offer to sell infringing products.

56. Upon information and belief, Defendants, with knowledge of the '250 Patent, and without authority, have actively induced and continue to actively induce infringement by end-users of at least one claim of the '250 Patent, under 35 U.S.C. § 271(b), by intentionally inducing the use, importation, offer for sale, and/or sale of the '250 Accused Products, intending to encourage, and in fact encouraging, end-users to directly infringe the '250 Patent. Defendants actively induce infringement by, *inter alia*, publishing manuals and promotional literature describing and instructing in the operation of the '250 Accused Products and by offering support and technical assistance to their customers who purchase the '250 Accused Products. *See, e.g.*, <https://support.sharkclean.com/hc/en-us/sections/9749532066332-IW1000-IW3000-Series>; <https://support.sharkclean.com/hc/en-us/sections/13878402324124-BU3000-BU3500-Series>. Omachron also actively induces infringement by assisting and encouraging SharkNinja with the

development of the '250 Accused Products. Defendants have actual knowledge of the existence of the '250 Patent since not later than the date of filing of this Complaint.

57. Upon information and belief, Defendants contributorily infringe the '250 Patent through their sale and offer to sell within the United States and/or importation into the United States of the '250 Accused Products and components such as spare and replacement parts of the '250 Accused Products, constituting a material part of the invention of the '250 Patent, knowing the same to be especially made or especially adapted for use in infringement of the '250 Patent, and not staple articles or commodities of commerce suitable for substantial non-infringing uses. Additionally, due to the specific designs of the '250 Accused Products, components thereof such as spare and replacement parts do not have any substantial noninfringing uses. Accordingly, in violation of 35 U.S.C. § 271(c), Defendants are contributing to the direct infringement of the '250 Patent by at least their customers and/or end users of the '250 Accused Products. The customers and/or end users of the '250 Accused Products directly infringe the '250 Patent by making or using the '250 Accused Products without authority.

58. Upon information and belief, in violation of 35 U.S.C. § 271(f)(1), Defendants, without authority, supply or cause to be supplied in or from the United States all or a substantial portion of the components of the '250 Accused Products, where such components are uncombined in whole or in part, in such manner as to actively induce the combination of such components outside of the United States in a manner that would infringe the '250 Patent if such combination occurred within the United States. Further, upon information and belief, in violation of 35 U.S.C. § 271(f)(2), Defendants, without authority, supply or cause to be supplied in or from the United States at least one component of the '250 Accused Products that is especially made or especially adapted for use as claimed in the '250 Patent and not a staple article or commodity of commerce

suitable for substantial noninfringing use, where such component is uncombined in whole or in part, knowing that such component is so made or adapted and intending that such component will be combined outside of the United States in a manner that would infringe the '250 Patent if such combination occurred within the United States.

59. To the extent applicable, Dyson has complied with 35 U.S.C. § 287(a) with respect to the '250 Patent.

60. Unless and until enjoined by this Court, Defendants will continue to directly infringe as well as induce and contribute to infringement of the '250 Patent. Defendants infringing acts are causing and will continue to cause Dyson irreparable harm, for which there is no adequate remedy at law. Under 35 U.S.C. § 283, Dyson is entitled to a permanent injunction against further infringement.

61. Due to Defendants' willful and deliberate infringement, the Court should award Dyson up to treble damages under 35 U.S.C. § 284 for infringement of the '250 Patent.

62. This case is exceptional, and Dyson is entitled to an award of attorneys' fees under 35 U.S.C. § 285.

COUNT TWO: INFRINGEMENT OF U.S. PATENT NO. 8,117,712

63. Dyson restates and incorporates by reference the allegations made in Paragraphs 1 through 62 of the Complaint above.

64. Upon information and belief, Defendants have infringed, and will continue to infringe, one or more claims of the '712 Patent under 35 U.S.C. § 271(a), either literally and/or under the doctrine of equivalents, by making, using, offering to sell, selling and/or importing into the United States certain vacuum cleaners, for example, the Vertex Pro Cordless, Stratos Cordless, Pet Cordless, Pet Plus Cordless, Shark Cordless Pro, and all other Shark vacuum cleaners with

materially similar designs as the forgoing. These vacuum cleaners are hereinafter referred to as the '712 Accused Products.

65. Exhibit 7 includes a chart comparing claim 1 of the '712 Patent to an exemplary '712 Accused Product. As set forth in Exhibit 7, the '712 Accused Products practice, in whole or in material part, the technology claimed in the '712 Patent. Accordingly, the '712 Accused Products infringe at least claim 1 of the '712 Patent. The '712 Accused Products are non-limiting examples identified based on publicly available information, and Dyson reserves the right to identify additional infringing activities, products, and services on the basis of information obtained, for example, during discovery.

66. Upon information and belief, Defendants knew that Dyson had patents covering vacuums based on its conduct monitoring patents, including patents of their competitors such as Dyson, and investigating and assessing potential infringement of those patents. For example, the '712 Patent is identified on Dyson's Marking website: <https://www.dyson.com/inside-dyson/patents>; <https://www.dyson.com/content/dam/dyson/inside-dyson/patents/Product%20Marking%20Report%20US%20V2.pdf>. Through such activities, Defendants either learned of the '712 Patent or subjectively believed there was a high probability that Dyson has patents covering features of vacuum products but took deliberate actions to avoid learning of that fact and which features were patented. Further, Defendants knew of the '712 Patent based on the patent prosecution activities of SharkNinja's wholly-owned subsidiary SharkNinja Operating, LLC. As one example, SharkNinja Operating, LLC's U.S. Patent No. 9,516,979 cites Dyson's U.S. Patent No. 7,931,716, a family member of the '712 Patent.

67. Further, Defendants knew of the '712 Patent because it is cited by the following U.S. patents assigned to Omachron IP: 9,301,666; 9,314,139; 9,320,401; 9,420,925; 9,427,126;

9,433,332; 9,451,853; 9,545,181; 9,585,530; 9,591,958; 9,591,952; 9,826,868; 9,888,817; 9,949,601; 9,962,047; 9,962,048; 9,986,880; 10,016,104; 10,016,105; 10,016,106; 10,080,472; 10,136,778; 10,165,914; 10,165,912; 10,251,519; 10,258,208; 10,258,210; 10,271,704; 10,299,643; 10,405,709; 10,506,904; 10,537,216; 10,568,477; 10,631,693; 10,674,884; 10,702,113; 10,722,086; 10,729,294; 10,750,913; 10,791,889; 10,827,891; 10,842,330; 11,006,799; 11,013,384; 11,013,378; 11,192,122; 11,241,129; 11,246,462; 11,285,495; 11,445,878; 11,478,116; 11,666,189; 11,666,193; 11,690,489; 11,730,327; 11,751,733; 11,751,740; 11,766,156; 11,779,174; 11,793,374; 11,857,142; 11,903,546; 11,918,170; and 11,969,133.

68. Thus, Defendants' knowledge of and intention to infringe the '712 Patent is evidenced by Exhibit 7, which establishes the striking similarities between the '712 Patent and the '712 Accused Products. Despite knowing of the '712 Patent or being willfully blind to the '712 Patent, Defendants continued to make, use, sell, and offer to sell infringing products.

69. Upon information and belief, Defendants, with knowledge of the '712 Patent, and without authority, have actively induced and continue to actively induce infringement by end-users of at least one claim of the '712 Patent, under 35 U.S.C. § 271(b), by intentionally inducing the use, importation, offer for sale, and/or sale of the '712 Accused Products, intending to encourage, and in fact encouraging, end-users to directly infringe the '712 Patent. Defendants actively induce infringement by, *inter alia*, publishing manuals and promotional literature describing and instructing in the operation of the '712 Accused Products and by offering support and technical assistance to their customers who purchase the '712 Accused Products. *See, e.g.*, <https://support.sharkclean.com/hc/en-us/sections/5227474863900-IZ800-Series>; <https://support.sharkclean.com/hc/en-us/sections/4407128350482-IZ600-Series>. Omachron also

actively induces infringement by assisting and encouraging SharkNinja with the development of the '712 Accused Products. Defendants has actual knowledge of the existence of the '712 Patent since not later than the date of filing of this Complaint.

70. Upon information and belief, Defendants contributorily infringe the '712 Patent through their sale and offers to sell within the United States and/or importation into the United States of the '712 Accused Products and components such as spare and replacement parts of the '712 Accused Products, constituting a material part of the invention of the '712 Patent, knowing the same to be especially made or especially adapted for use in infringement of the '712 Patent, and not staple articles or commodities of commerce suitable for substantial non-infringing uses. Additionally, due to the specific designs of the '712 Accused Products, components thereof such as spare and replacement parts do not have any substantial noninfringing uses. Accordingly, in violation of 35 U.S.C. § 271(c), Defendants are contributing to the direct infringement of the '712 Patent by at least their customers and/or end users of the '712 Accused Products. The customers and/or end users of the '712 Accused Products directly infringe the '712 Patent by making or using the '712 Accused Products without authority.

71. Upon information and belief, in violation of 35 U.S.C. § 271(f)(1), Defendants, without authority, supply or cause to be supplied in or from the United States all or a substantial portion of the components of the '712 Accused Products, where such components are uncombined in whole or in part, in such manner as to actively induce the combination of such components outside of the United States in a manner that would infringe the '712 Patent if such combination occurred within the United States. Further, upon information and belief, in violation of 35 U.S.C. § 271(f)(2), Defendants, without authority, supply or cause to be supplied in or from the United States at least one component of the '712 Accused Products that is especially made or especially

adapted for use as claimed in the '712 Patent and not a staple article or commodity of commerce suitable for substantial noninfringing use, where such component is uncombined in whole or in part, knowing that such component is so made or adapted and intending that such component will be combined outside of the United States in a manner that would infringe the '712 Patent if such combination occurred within the United States.

72. To the extent applicable, Dyson has complied with 35 U.S.C. § 287(a) with respect to the '712 Patent.

73. Unless and until enjoined by this Court, Defendants will continue to directly infringe as well as induce and contribute to infringement of the '712 Patent. Defendants infringing acts are causing and will continue to cause Dyson irreparable harm, for which there is no adequate remedy at law. Under 35 U.S.C. § 283, Dyson is entitled to a permanent injunction against further infringement.

74. Due to Defendants' willful and deliberate infringement, the Court should award Dyson up to treble damages under 35 U.S.C. § 284 for infringement of the '712 Patent.

75. This case is exceptional, and Dyson is entitled to an award of attorneys' fees under 35 U.S.C. § 285.

COUNT THREE: INFRINGEMENT OF U.S. PATENT NO. 7,603,745

76. Dyson restates and incorporates by reference the allegations made in Paragraphs 1 through 75 of the Complaint above.

77. Upon information and belief, Defendants have infringed, and will continue to infringe, one or more claims of the '745 Patent under 35 U.S.C. § 271(a), either literally and/or under the doctrine of equivalents, by making, using, offering to sell, selling and/or importing into the United States certain vacuum cleaners, for example, the Detect Pro, Clean & Empty Cordless Stick Vacuum, Vertex Pro Cordless, Stratos Cordless, Shark Cordless Pro, and all other Shark

vacuum cleaners with materially similar designs as the forgoing. These vacuum cleaners are hereinafter referred to as the '745 Accused Products.

78. Exhibit 8 includes a chart comparing claim 5 of the '745 Patent to an exemplary '745 Accused Product. As set forth in Exhibit 8, the '745 Accused Products practice, in whole or in material part, the technology claimed in the '745 Patent. Accordingly, the '745 Accused Products infringe at least claim 5 of the '745 Patent. The '745 Accused Products are non-limiting examples identified based on publicly available information, and Dyson reserves the right to identify additional infringing activities, products, and services on the basis of information obtained, for example, during discovery.

79. Upon information and belief, Defendants knew that Dyson had patents covering vacuums based on their conduct monitoring patents, including patents of their competitors such as Dyson, and investigating and assessing potential infringement of those patents. For example, the '745 Patent is identified on Dyson's Marking website: <https://www.dyson.com/inside-dyson/patents>; <https://www.dyson.com/content/dam/dyson/inside-dyson/patents/Product%20Marking%20Report%20US%20V2.pdf>. Through such activities, Defendants either learned of the '745 Patent or subjectively believed there was a high probability that Dyson has patents covering features of vacuum products but took deliberate actions to avoid learning of that fact and which features were patented. Further, Defendants knew of the '745 Patent because it is cited by the following U.S. patent assigned to SharkNinja's wholly-owned subsidiary SharkNinja Operating, LLC: 8,152,877.

80. Thus, Defendants' knowledge of and intention to infringe the '745 Patent is evidenced by Exhibit 8, which establishes the striking similarities between the '745 Patent and the

'745 Accused Products. Despite knowing of the '745 Patent or being willfully blind to the '745 Patent, Defendants continued to make, use, sell, and offer to sell infringing products.

81. Upon information and belief, Defendants, with knowledge of the '745 Patent, and without authority, have actively induced and continue to actively induce infringement by end-users of at least one claim of the '745 Patent, under 35 U.S.C. § 271(b), by intentionally inducing the use, importation, offer for sale, and/or sale of the '745 Accused Products, intending to encourage, and in fact encouraging, end-users to directly infringe the '745 Patent. Defendants actively induced infringement by, *inter alia*, publishing manuals and promotional literature describing and instructing in the operation of the '745 Accused Products and by offering support and technical assistance to their customers who purchase the '745 Accused Products. *See, e.g.*, <https://support.sharkclean.com/hc/en-us/sections/9749532066332-IW1000-IW3000-Series>; <https://support.sharkclean.com/hc/en-us/sections/13878402324124-BU3000-BU3500-Series>. Omachron also actively induces infringement by assisting and encouraging SharkNinja with the development of the '745 Accused Products. Defendants have actual knowledge of the existence of the '745 Patent since not later than the date of filing of this Complaint.

82. Upon information and belief, Defendants contributorily infringe the '745 Patent through their sale and offers to sell within the United States and/or importation into the United States of the '745 Accused Products and components such as spare and replacement parts of the '745 Accused Products, constituting a material part of the invention of the '745 Patent, knowing the same to be especially made or especially adapted for use in infringement of the '745 Patent, and not staple articles or commodities of commerce suitable for substantial non-infringing uses. Additionally, due to the specific designs of the '745 Accused Products, components thereof such as spare and replacement parts do not have any substantial noninfringing uses. Accordingly, in

violation of 35 U.S.C. § 271(c), Defendants are contributing to the direct infringement of the '745 Patent by at least their customers and/or end users of the '745 Accused Products. The customers and/or end users of the '745 Accused Products directly infringe the '745 Patent by making or using the '745 Accused Products without authority.

83. Upon information and belief, in violation of 35 U.S.C. § 271(f)(1), Defendants, without authority, supply or cause to be supplied in or from the United States all or a substantial portion of the components of the '745 Accused Products, where such components are uncombined in whole or in part, in such manner as to actively induce the combination of such components outside of the United States in a manner that would infringe the '745 Patent if such combination occurred within the United States. Further, upon information and belief, in violation of 35 U.S.C. § 271(f)(2), Defendants, without authority, supply or cause to be supplied in or from the United States at least one component of the '745 Accused Products that is especially made or especially adapted for use as claimed in the '745 Patent and not a staple article or commodity of commerce suitable for substantial noninfringing use, where such component is uncombined in whole or in part, knowing that such component is so made or adapted and intending that such component will be combined outside of the United States in a manner that would infringe the '745 Patent if such combination occurred within the United States.

84. To the extent applicable, Dyson has complied with 35 U.S.C. § 287(a) with respect to the '745 Patent.

85. Unless and until enjoined by this Court, Defendants will continue to directly infringe as well as induce and contribute to infringement of the '745 Patent. Defendants infringing acts are causing and will continue to cause Dyson irreparable harm, for which there is no adequate

remedy at law. Under 35 U.S.C. § 283, Dyson is entitled to a permanent injunction against further infringement.

86. Due to Defendants' willful and deliberate infringement, the Court should award Dyson up to treble damages under 35 U.S.C. § 284 for infringement of the '745 Patent.

87. This case is exceptional, and Dyson is entitled to an award of attorneys' fees under 35 U.S.C. § 285.

COUNT FOUR: INFRINGEMENT OF U.S. PATENT NO. 8,444,731

88. Dyson restates and incorporates by reference the allegations made in Paragraphs 1 through 87 of the Complaint above.

89. Upon information and belief, Defendants have infringed, and will continue to infringe, one or more claims of the '731 Patent under 35 U.S.C. § 271(a), either literally and/or under the doctrine of equivalents, by making, using, offering to sell, selling and/or importing into the United States certain vacuum cleaners, for example, the Pet Cordless, Pet Plus Cordless, Rocket Cordless, Rocket Pro Cordless, and all other Shark vacuum cleaners with materially similar designs as the forgoing. These vacuum cleaners are hereinafter referred to as the '731 Accused Products.

90. Exhibit 9 includes charts comparing claim 1 of the '731 Patent to an exemplary '731 Accused Product. As set forth in Exhibit 9, the '731 Accused Products practice, in whole or in material part, the technology claimed in the '731 Patent. Accordingly, the '731 Accused Products infringe at least claim 1 of the '731 Patent. The '731 Accused Products are non-limiting examples identified based on publicly available information, and Dyson reserves the right to identify additional infringing activities, products, and services on the basis of information obtained, for example, during discovery.

91. Upon information and belief, Defendants knew that Dyson had patents covering vacuums based on its conduct monitoring patents, including patents of its competitors such as Dyson, and investigating and assessing potential infringement of those patents. For example, the '731 Patent is identified on Dyson's Marking website: <https://www.dyson.com/inside-dyson/patents>; <https://www.dyson.com/content/dam/dyson/inside-dyson/patents/Product%20Marking%20Report%20US%20V2.pdf>. Through such activities, Defendants either learned of the '731 Patent or subjectively believed there was a high probability that Dyson has patents covering features of vacuum products but took deliberate actions to avoid learning of that fact and which features were patented. Further, Defendants knew of the '731 Patent because it is cited by the following U.S. patent assigned to SharkNinja's wholly-owned subsidiary SharkNinja Operating, LLC: 11,213,177.

92. Further, Defendants knew of the '731 Patent because it is cited by the following U.S. patents assigned to Omachron IP: 9,826,868; 9,962,047; 9,962,048; 9,986,880; 10,016,105; 10,016,104; 10,016,106; 10,105,023; 10,165,914; 10,214,349; 10,244,909; 10,244,910; 10,258,210; 10,258,208; 10,271,704; 10,271,698; 10,299,643; 10,322,873; 10,376,112; 10,405,709; 10,433,686; 10,464,746; 10,499,781; 10,506,904; 10,537,216; 10,568,477; 10,631,693; 10,674,884; 10,702,113; 10,722,086; 10,729,294; 10,750,913; 10,765,277; 10,791,889; 10,827,891; 10,842,330; 11,013,378 11,229,335; 11,241,129; 11,246,462; 11,285,495; 11,690,489; 11,751,740; 11,751,733; 11,857,140; 11,896,186; 11,918,170; 11,950,745; and 11,969,133.

93. Thus, Defendants' knowledge of and intention to infringe the '731 Patent is evidenced by Exhibit 9, which establishes the striking similarities between the '731 Patent and the

'731 Accused Products. Despite knowing of the '731 Patent or being willfully blind to the '731 Patent, Defendants continued to make, use, sell, and offer to sell infringing products.

94. Upon information and belief, Defendants, with knowledge of the '731 Patent, and without authority, have actively induced and continue to actively induce infringement by end-users of at least one claim of the '731 Patent, under 35 U.S.C. § 271(b), by intentionally inducing the use, importation, offer for sale, and/or sale of the '731 Accused Products, intending to encourage, and in fact encouraging, end-users to directly infringe the '731 Patent. Defendants actively induced infringement by, *inter alia*, publishing manuals and promotional literature describing and instructing in the operation of the '731 Accused Products and by offering support and technical assistance to their customers who purchase the '731 Accused Products. *See, e.g.*, <https://support.sharkclean.com/hc/en-us/sections/360005951699-IX140-IZ140-Series>; <https://support.sharkclean.com/hc/en-us/sections/360005914740-IZ160-QZ160-Series>. Omachron also actively induces infringement by assisting and encouraging SharkNinja with the development of the '731 Accused Products. Defendants have actual knowledge of the existence of the '731 Patent since not later than the date of filing of this Complaint.

95. Upon information and belief, Defendants contributorily infringe the '731 Patent through their sale and offers to sell within the United States and/or importation into the United States of the '731 Accused Products and components such as spare and replacement parts of the '731 Accused Products, constituting a material part of the invention of the '731 Patent, knowing the same to be especially made or especially adapted for use in infringement of the '731 Patent, and not staple articles or commodities of commerce suitable for substantial non-infringing uses. Additionally, due to the specific designs of the '731 Accused Products, components thereof such as spare and replacement parts do not have any substantial noninfringing uses. Accordingly, in

violation of 35 U.S.C. § 271(c), Defendants are contributing to the direct infringement of the '731 Patent by at least their customers and/or end users of the '731 Accused Products. The customers and/or end users of the '731 Accused Products directly infringe the '731 Patent by making or using the '731 Accused Products without authority.

96. Upon information and belief, in violation of 35 U.S.C. § 271(f)(1), Defendants, without authority, supply or cause to be supplied in or from the United States all or a substantial portion of the components of the '731 Accused Products, where such components are uncombined in whole or in part, in such manner as to actively induce the combination of such components outside of the United States in a manner that would infringe the '731 Patent if such combination occurred within the United States. Further, upon information and belief, in violation of 35 U.S.C. § 271(f)(2), Defendants, without authority, supply or cause to be supplied in or from the United States at least one component of the '731 Accused Products that is especially made or especially adapted for use as claimed in the '731 Patent and not a staple article or commodity of commerce suitable for substantial noninfringing use, where such component is uncombined in whole or in part, knowing that such component is so made or adapted and intending that such component will be combined outside of the United States in a manner that would infringe the '731 Patent if such combination occurred within the United States.

97. To the extent applicable, Dyson has complied with 35 U.S.C. § 287(a) with respect to the '731 Patent.

98. Unless and until enjoined by this Court, Defendants will continue to directly infringe as well as induce and contribute to infringement of the '731 Patent. Defendants infringing acts are causing and will continue to cause Dyson irreparable harm, for which there is no adequate

remedy at law. Under 35 U.S.C. § 283, Dyson is entitled to a permanent injunction against further infringement.

99. Due to Defendants' willful and deliberate infringement, the Court should award Dyson up to treble damages under 35 U.S.C. § 284 for infringement of the '731 Patent.

100. This case is exceptional, and Dyson is entitled to an award of attorneys' fees under 35 U.S.C. § 285.

COUNT FIVE: INFRINGEMENT OF U.S. PATENT NO. 8,100,999

101. Dyson restates and incorporates by reference the allegations made in Paragraphs 1 through 100 of the Complaint above.

102. Upon information and belief, Defendants have infringed, and will continue to infringe, one or more claims of the '999 Patent under 35 U.S.C. § 271(a), either literally and/or under the doctrine of equivalents, by making, using, offering to sell, selling and/or importing into the United States certain vacuum cleaners, for example, the Shark Wandvac and all other Shark vacuum cleaners with materially similar designs. These vacuum cleaners are hereinafter referred to as the '999 Accused Products.

103. Exhibit 10 includes charts comparing claim 1 of the '999 Patent to an exemplary '999 Accused Product. As set forth in Exhibit 10, the '999 Accused Products practice, in whole or in material part, the technology claimed in the '999 Patent. Accordingly, the '999 Accused Products infringe at least claim 1 of the '999 Patent. The '999 Accused Products are non-limiting examples identified based on publicly available information, and Dyson reserves the right to identify additional infringing activities, products, and services on the basis of information obtained, for example, during discovery.

104. Upon information and belief, Defendants knew that Dyson had patents covering vacuums based on their conduct monitoring patents, including patents of its competitors such as

Dyson, and investigating and assessing potential infringement of those patents. For example, the '999 Patent is identified on Dyson's Marking website: <https://www.dyson.com/inside-dyson/patents>; <https://www.dyson.com/content/dam/dyson/inside-dyson/patents/Product%20Marking%20Report%20US%20V2.pdf>. Through such activities, Defendants either learned of the '999 Patent or subjectively believed there was a high probability that Dyson has patents covering features of vacuum products but took deliberate actions to avoid learning of that fact and which features were patented. Further, on information and belief, Defendants knew of the '999 Patent based on the patent prosecution activities of SharkNinja's wholly-owned subsidiary SharkNinja Operating, LLC.

105. Further, Defendants knew of the '999 Patent because it is cited by the following U.S. patents assigned to Omachron IP: 9,826,868; 9,962,047; 9,962,048; 9,986,880; 10,016,105; 10,016,104; 10,016,106; 10,105,023; 10,165,914; 10,214,349; 10,244,909; 10,244,910; 10,258,210; 10,258,208; 10,271,704; 10,271,698; 10,299,643; 10,322,873; 10,376,112; 10,405,709; 10,433,686; 10,464,746; 10,499,781; 10,506,904; 10,537,216; 10,568,477; 10,631,693; 10,674,884; 10,702,113; 10,722,086; 10,729,294; 10,750,913; 10,765,277; 10,791,889; 10,827,891; 10,842,330; 11,013,378; 11,229,335; 11,241,129; 11,246,462; 11,285,495; 11,690,489; 11,751,740; 11,751,733; 11,857,140; 11,896,186; 11,918,170; 11,950,745; and 11,969,133.

106. Thus, Defendants' knowledge of and intention to infringe the '999 Patent is evidenced by Exhibit 10, which establishes the striking similarities between the '999 Patent and the '999 Accused Products. Despite knowing of the '999 Patent or being willfully blind to the '999 Patent, Defendants continued to make, use, sell, and offer to sell infringing products.

107. Upon information and belief, Defendants, with knowledge of the '999 Patent, and without authority, have actively induced and continue to actively induce infringement by end-users of at least one claim of the '999 Patent, under 35 U.S.C. § 271(b), by intentionally inducing the use, importation, offer for sale, and/or sale of the '999 Accused Products, intending to encourage, and in fact encouraging, end-users to directly infringe the '999 Patent. Defendants actively induced infringement by, *inter alia*, publishing manuals and promotional literature describing and instructing in the operation of the '999 Accused Products and by offering support and technical assistance to their customers who purchase the '999 Accused Products. *See, e.g.*, <https://support.sharkclean.com/hc/en-us/sections/360005925380-WV200-Series>. Omachron also actively induces infringement by assisting and encouraging SharkNinja with the development of the '999 Accused Products. Defendants have actual knowledge of the existence of the '999 Patent since not later than the date of filing of this Complaint.

108. Upon information and belief, SharkNinja contributorily infringes the '999 Patent through their sale and offers to sell within the United States and/or importation into the United States of the '999 Accused Products and components such as spare and replacement parts of the '999 Accused Products, constituting a material part of the invention of the '999 Patent, knowing the same to be especially made or especially adapted for use in infringement of the '999 Patent, and not staple articles or commodities of commerce suitable for substantial non-infringing uses. Additionally, due to the specific designs of the '999 Accused Products, components thereof such as spare and replacement parts do not have any substantial noninfringing uses. Accordingly, in violation of 35 U.S.C. § 271(c), Defendants are contributing to the direct infringement of the '999 Patent by at least their customers and/or end users of the '999 Accused Products. The customers

and/or end users of the '999 Accused Products directly infringe the '999 Patent by making or using the '999 Accused Products without authority.

109. Upon information and belief, in violation of 35 U.S.C. § 271(f)(1), Defendants, without authority, supply or cause to be supplied in or from the United States all or a substantial portion of the components of the '999 Accused Products, where such components are uncombined in whole or in part, in such manner as to actively induce the combination of such components outside of the United States in a manner that would infringe the '999 Patent if such combination occurred within the United States. Further, upon information and belief, in violation of 35 U.S.C. § 271(f)(2), Defendants, without authority, supply or cause to be supplied in or from the United States at least one component of the '999 Accused Products that is especially made or especially adapted for use as claimed in the '999 Patent and not a staple article or commodity of commerce suitable for substantial noninfringing use, where such component is uncombined in whole or in part, knowing that such component is so made or adapted and intending that such component will be combined outside of the United States in a manner that would infringe the '999 Patent if such combination occurred within the United States.

110. To the extent applicable, Dyson has complied with 35 U.S.C. § 287(a) with respect to the '999 Patent.

111. Unless and until enjoined by this Court, Defendants will continue to directly infringe as well as induce and contribute to infringement of the '999 Patent. Defendants infringing acts are causing and will continue to cause Dyson irreparable harm, for which there is no adequate remedy at law. Under 35 U.S.C. § 283, Dyson is entitled to a permanent injunction against further infringement.

112. Due to Defendants' willful and deliberate infringement, the Court should award Dyson up to treble damages under 35 U.S.C. § 284 for infringement of the '999 Patent.

113. This case is exceptional, and Dyson is entitled to an award of attorneys' fees under 35 U.S.C. § 285.

PRAYER FOR RELIEF

WHEREFORE, Dyson requests the following relief:

1. A judgment declaring that Defendants have infringed and continue to infringe one or more claims of U.S. Patent Nos. 8,302,250; 8,117,712; 7,603,745; 8,444,731; and 8,100,999 under 35 U.S.C. §§ 271(a), (b), (c) and/or (f);
2. A permanent injunction of Defendants' infringing acts;
3. An award of all damages sustained by Dyson as a result of Defendants' infringing activities which is no less than a reasonable royalty, together with prejudgment interest;
4. An award of enhanced damages pursuant to 28 U.S.C. § 284;
5. An order finding that this case is an exceptional case under 35 U.S.C. § 285 and awarding Dyson its reasonable attorneys' fees, expenses, and costs in connection with this action;
6. Any other equitable and legal relief that this Court may deem just and proper.

JURY DEMAND

Pursuant to Rule 38 of the Federal Rules of Civil Procedure and Civil L.R. 38-1, Dyson hereby demands a trial by jury on all issues so triable in this Complaint.

DATED: May 24, 2024

Respectfully submitted,

/s/ Melissa R. Smith

Melissa R. Smith
(TX State Bar No. 24001351)
GILLAM & SMITH, LLP
303 S. Washington Ave.
Marshall, TX 75670
Telephone: (903) 934-8450
Facsimile: (903) 934-9257
Email: melissa@gillamsmithlaw.com

Bryan Hales (pro hac vice motion
forthcoming)

Jay Emerick (pro hac vice motion
forthcoming)

KIRKLAND & ELLIS LLP
333 West Wolf Point Plaza
Chicago, IL 60654
Tel: 312.862.2000
Fax: 312.862.2200
bryan.hales@kirkland.com
jay.emerick@kirkland.com

Attorneys for Plaintiffs