

**IN THE UNITED STATES DISTRICT COURT
FOR THE NORTHERN DISTRICT OF ILLINOIS
EASTERN DIVISION**

Meihua Yan,)	
)	
Plaintiffs,)	
)	Case No. 1:24-cv-xxxx
v.)	
)	
The Individuals, Partnerships and)	
Unincorporated Associations Identified on)	
Schedule A,)	
)	
Defendants)	

Complaint

NOW COMES Meihua Yan (“Plaintiff”), by and through his undersigned counsel, and hereby brings this Complaint against the Individuals, Partnerships, and Unidentified Associations identified on Schedule A attached hereto (collectively, “Defendants”) and alleges as follows:

Nature of the Action

1. This action has been filed by Plaintiff to combat e-commerce store operators who trade upon Plaintiff’s intellectual property by making, using, offering for sale, selling and/or importing into the United States for subsequent sale or use unauthorized and unlicensed products which infringe Plaintiff’s patented design (the “Infringing Products”).
2. Defendants create fully-interactive, commercial Internet stores operating under at least the online marketplace accounts identified in **Schedule A**, attached hereto (collectively, the “Defendant Online Stores”) that are intentionally designed to appear to be selling genuine Plaintiff Products, while actually making, using, offering for sale, selling, and/or importing into the United States for subsequent sale or use Infringing Products to unknowing consumers.

3. The Defendant Online Stores share identifiers establishing a logical relationship between them, suggesting that Defendants' operation arises out of the same transaction, occurrence, or series of transactions or occurrences.
4. Defendants attempt to avoid and mitigate liability by operating under one or more e-commerce stores to conceal both their identities and the full scope and interworking of their infringing operation. Plaintiff is forced to file this action to combat Defendants' infringement of its patented design, as well as to protect unknowing consumers from purchasing Infringing Products over the Internet.
5. Plaintiff has been and continues to be irreparably damaged from the loss of its lawful patent rights to exclude others from, inter alia, making, using, selling, offering for sale, and importing its patented designs as a result of Defendants' actions and seeks injunctive and monetary relief.

Parties

6. Plaintiff is an individual and Chinese citizen and is the assignee of all rights in and to the Plaintiff Design.
7. Defendants are individuals and business entities who, upon information and belief, reside and/or operate in the People's Republic of China, or other foreign jurisdictions, or redistribute products from the same or similar sources in those locations. Defendants conduct business throughout the United States, including within the State of Illinois and this Judicial District, through the operation of the fully interactive Defendant Online Stores which operate on commercial online marketplaces. Each Defendant targets the United States, including Illinois and this Judicial District, and has offered to sell, and, on information and belief, has

sold and continues to sell Infringing Products to consumers within the United States, including the State of Illinois and this Judicial District.

8. On information and belief, Defendants either individually or jointly, operate the Defendant Online Stores. Tactics used by Defendants to conceal their identities and the full scope of their operation make it virtually impossible for Plaintiff to learn Defendants' true identities and the exact interworking of their network. If Defendants provide additional credible information regarding their identities, Plaintiff will take appropriate steps to amend the Complaint.

Jurisdiction and Venue

9. This Court has subject matter jurisdiction over Plaintiff's claims pursuant to 28 U.S.C. §§ 1331, 1338 (for claims arising under the U.S. Patent Act).
10. Venue is proper in this Court pursuant to 28 U.S.C. § 1391, and this Court may properly exercise personal jurisdiction over Defendants since each of the Defendants directly targets business activities toward consumers in the United States, including Illinois and this Judicial District. Defendants reach out to do business with residents of Illinois and this Judicial District by operating one or more commercial, fully-interactive Defendant Online Stores through which residents of Illinois and this Judicial District can purchase and/or have purchased products being offered and sold featuring Plaintiff's patented design. Each Defendant has targeted sales from residents of Illinois and this Judicial District by setting up and operating one or more Defendant Online Store that accepts payment in U.S. dollars and offers shipping to addresses within Illinois and this Judicial District, and, on information and belief, each Defendant has offered to sell and sold products featuring Plaintiff's patented designs to residents of Illinois. Each Defendant has committed and is committing tortious

acts in Illinois and this Judicial District, is engaging in interstate commerce, and has wrongfully caused Plaintiff substantial injury in the State of Illinois.

Plaintiff's Business

11. Plaintiff is engaged in the design, distribution, marketing, offering for sale, and sale of various industrial designs and consumer products since 2020 (the "Plaintiff Products") including without limitation faucets.
12. The Plaintiff Products are distributed and sold to consumers throughout the United States, including in Illinois and in this judicial district.
13. Plaintiff Products are known for their distinctive patented design. This design is broadly recognized by consumers. Products tailored after this design (herein referred to as the "Plaintiff Design") are associated with the quality and innovation that the public has come to expect from Plaintiff Products.
14. Plaintiff is the lawful assignee of all right, title, and interest in and to the Plaintiff Design. Attached hereto as **Exhibit 1** is a true and correct copy of the United States Patent for the Plaintiff Design.

Defendants' Unlawful Conduct

15. Plaintiff has identified numerous fully interactive, ecommerce stores, including the Defendant Online Stores, which are or recently were offering for sale and/or selling Infringing Products to consumers in this judicial district and throughout the United States.
16. Marketplaces like eBay, Wayfair, Walmart, and Amazon, among others, allow merchants to quickly "set up shop" and flood the market with unauthorized goods which displace actual sales manufacturers would otherwise enjoy.

17. It has been estimated that e-commerce intellectual property infringement costs merchants in the U.S. alone nearly \$41 billion¹ with Department of Homeland Security seizures of infringing goods increasing more than 10-fold between 2000 and 2018² and a street value of seized goods increasing 246% from 2017 to 2022.³
18. Infringing and pirated products account for billions in economic losses, resulting in tens of thousands of lost jobs for legitimate businesses and broader economic losses, including lost tax revenue.
19. Third party service providers like those used by Defendants do not adequately subject new sellers to robust verification and confirmation of their identities, allowing infringers to “routinely use false or inaccurate names and addresses when registering with these e-commerce platforms.”⁴
20. DHS has observed that “at least some e-commerce platforms, little identifying information is necessary for [an infringer] to begin selling” and recommending that “[s]ignificantly enhanced vetting of third-party sellers” is necessary. Infringers hedge against the risk of being caught and having their websites taken down from an e-commerce platform by preemptively establishing multiple virtual storefronts.⁵

¹ The National Bureau of Asian Research, *The Report of the Commission on the Theft of American Intellectual Property*, at 9, Pub. The Commission on the Theft of American Intellectual Property 2017, available at http://www.ipcommission.org/report/IP_Commission_Report_Update_2017.pdf.

² U.S. Department of Homeland Security, *Combating Trafficking in Counterfeit and Pirated Goods Report to the President of the United States*, January 24, 2020.

³ U.S. Customs and Border Protection Office of Trade, FY 2022 Fact Sheet Intellectual Property Rights, available at <https://www.cbp.gov/sites/default/files/assets/documents/2023-Mar/IPR%20Fact%20Sheet%20FY2022%20Final%20Draft%20%28508%29%20%28004%29%20%282%29.pdf>

⁴ Daniel C.K. Chow, *Alibaba, Amazon, and Counterfeiting in the Age of the Internet*, 40 NW. J. INT’L L. & BUS. 157, 186 (2020).

⁵ *Combating Trafficking in Counterfeit and Pirated Goods Report to the President of the United States*, at p. 22.

21. Since platforms generally do not require a seller on a third-party marketplace to identify the underlying business entity, infringers can have many different profiles that can appear unrelated even though they are commonly owned and operated.⁶
22. The success of Plaintiff's sales of the Plaintiff Products has resulted in substantial infringing activity and other attempts to misappropriate Plaintiff's proprietary rights. Plaintiff has policed the use of the Plaintiff Design and has identified many online product listings on marketplaces such as eBay, Walmart and Amazon, and other Internet locations offering for sale and, on information and belief, selling products featuring the Plaintiff Design throughout the United States including this Judicial District.
23. Defendants enable and facilitate the sales of their Infringing Products by setting up and operating commercial, fully interactive, Defendant Online Stores, offering shipping to the United States, including Illinois, accepting payment in U.S. dollars and, on information and belief, offering to sell or selling Infringing Products to residents of Illinois and this judicial district.
24. Defendants collectively employ and benefit from substantially similar advertising and marketing strategies. For example, Defendants facilitate sales by designing the Defendant Online Stores so that they appear to unknowing consumers to be authorized online retailers, outlet stores, or wholesalers. The Defendant Online Stores appear sophisticated and accept payment in U.S. dollars via credit cards, Alipay, Amazon Pay, Western Union and/or PayPal. The Defendant Online Stores often include content and images which make it very difficult for consumers to distinguish such stores from those of an authorized retailer. Plaintiff has

⁶ Id., at p. 39.

not licensed or authorized Defendants to use the Plaintiff Design, and on information and belief none of the Defendants are authorized retailers of genuine Plaintiff Products.

- 25.** On information and belief, Defendants engaged in fraudulent conduct when registering the Defendant Online Stores by providing false, misleading and/or incomplete information to their respective ecommerce platforms. On information and belief, certain Defendants have anonymously registered and maintained the Defendant Online Stores to prevent discovery of their true identities and the scope of their e-commerce operation.
- 26.** Defendants take pains to conceal their identities from the public, almost invariably using meaningless store names and addresses which do not identify Defendants. Defendants may operate several stores simultaneously using fictitious identities such as those listed in Schedule A, as well as other fictitious names and addresses. Moreover, infringers like Defendants will often register or acquire new store accounts under new fictitious names when they receive notice that one or more stores have been subject to law suit which allows them to avoid enforcement efforts and continue offering for sale and selling Infringing Products. The use of these store registration schemes is one of many common tactics used by the Defendants to conceal their identities and the full scope and interworking of their operation, and to avoid being halted.
- 27.** Despite Defendants operating under multiple fictitious names, the Defendant Online Stores bear numerous similarities, such as templates with common design elements that intentionally omit any contact information or other information for identifying Defendants or other stores they operate or use. The Defendant Online Stores include other notable common features, such as use of the same registration patterns, accepted payment methods, check-out methods, keywords, illegitimate search engine optimization (SEO), advertising tactics,

similarities in price and quantities, the same incorrect grammar and misspellings, and/or the use of the same text and product imagery.

- 28.** Infringers like Defendants will typically ship infringing products in small quantities via international mail to mitigate detection by U.S. Customs and Border Protection. Further, they will typically operate multiple credit card merchant accounts or use layers of payment gateways to forestall their cashflow being interrupted due to trademark enforcement efforts. On information and belief, Defendants utilize offshore bank accounts and routinely move funds from U.S.-based merchant accounts (e.g., within China) outside the jurisdiction of this Court.
- 29.** On information and belief, Defendants are in constant communication with each other and regularly participate in QQ.com and WeChat chat rooms and through websites such as sellerdefense.cn, kaidianyo.com, and kuajingvs.com regarding tactics for operating multiple accounts, evading detection, pending litigation, and potential new lawsuits.
- 30.** On information and belief, Defendants maintain offshore bank accounts and regularly move funds from their financial accounts to offshore bank accounts outside the jurisdiction of this Court and will do so to avoid payment of any monetary judgment awarded to Plaintiff by this Court.
- 31.** On information and belief, Defendants are an interrelated group of infringers working in active concert to knowingly and willfully manufacture, import, distribute, offer for sale, and sell Infringing Products in the same transaction, occurrence, or series of transactions or occurrences. Defendants, without any authorization or license from Plaintiff, have knowingly and willfully offered for sale, sold, and/or imported into the United States for subsequent resale or use products that infringe directly and/or indirectly the Plaintiff

Design. Each Defendant Online Store offers shipping to the United States, including Illinois and this Judicial District, and on information and belief, each Defendant has offered to sell or sold Infringing Products into the United States and Illinois, including this Judicial District, over the internet.

32. Defendants' infringement of the Plaintiff Design in the making, using, offering for sale, selling, and/or importing into the United States for subsequent sale or use of the Infringing Products was willful.

33. Defendants' infringement of the Plaintiff Design in connection with the making, using, offering for sale, selling, and/or importing into the United States for subsequent sale or use of the Infringing Products, including the making, using, offering for sale, selling, and/or importing into the United States for subsequent sale or use of Infringing Products into Illinois, including this judicial district, is irreparably harming Plaintiff.

Count I – Patent Infringement (25 U.S.C. § 271)

34. Plaintiff repeats and realleges the allegations of Paragraphs 1 – 33 as if fully set forth herein.

35. Defendants are making, using, offering for sale, selling, and/or importing into the United States for subsequent sale or use Infringing Products that infringe directly and/or indirectly the ornamental design claimed in Plaintiff Design.

36. Defendants have infringed Plaintiff Design through the aforesaid acts and will continue to do so unless enjoined by this Court. Defendants' wrongful conduct has caused Plaintiff to suffer irreparable harm resulting from the loss of its lawful patent rights to exclude others from making, using, selling, offering for sale, and importing the patented invention. Plaintiff is entitled to injunctive relief pursuant to 35 U.S.C. § 283.

37. Plaintiff is entitled to recover damages adequate to compensate for the infringement,

including Defendants' profits pursuant to 35 U.S.C. § 289. Plaintiff is entitled to recover any other damages as appropriate pursuant to 35 U.S.C. § 284.

WHEREFORE, Plaintiff prays for judgment against Defendants as follows:

- A.** That Defendants, their affiliates, officers, agents, servants, employees, attorneys, confederates, and all persons acting for, with, by, through, under or in active concert with them be permanently enjoined and restrained from:
- a.** making, using, offering for sale, selling, and/or importing into the United States for subsequent sale or use any products not authorized by Plaintiff and that include any reproduction, copy or colorable imitation of the designs claimed in the Plaintiff Design;
 - b.** aiding, abetting, contributing to, or otherwise assisting anyone in infringing upon the Plaintiff Design; and
 - c.** effecting assignments or transfers, forming new entities or associations or utilizing any other device for the purpose of circumventing or otherwise avoiding the prohibitions set forth in Subparagraphs (a) and (b).
- B.** Entry of an Order that, upon Plaintiff's request, those with notice of the injunction, including, without limitation, any online marketplace platforms such as Amazon, Wish, eBay, and Walmart (collectively, the "Third Party Providers") shall disable and cease displaying any advertisements used by or associated with Defendants in connection with the sale of goods that infringe the ornamental designs claimed in the Plaintiff Design;
- C.** That Plaintiff be awarded such damages as it shall prove at trial against Defendants that are adequate to compensate Plaintiff for Defendants' infringement of the Plaintiff Design, but in

no event less than a reasonable royalty for the use made of the inventions by the Defendants, together with interest and costs, pursuant to 35 U.S.C. § 284;

- D. That the amount of damages awarded to Plaintiff to compensate it for infringement of the Plaintiff Design be increased by three times the amount thereof, as provided by 35 U.S.C. § 284;
- E. In the alternative, that Plaintiff be awarded all profits realized by Defendants from their infringement of the Plaintiff Design, pursuant to 35 U.S.C. § 289;
- F. That Plaintiff be awarded its reasonable attorneys' fees and costs; and
- G. Award any and all other relief that this Court deems just and proper.

Dated: June 4, 2024

Respectfully,

/s/Carla Buterman-Carter

Carla Carter

Michael Davis

Davis & Carter LLC

53 W. Jackson Blvd., Ste. 1560

Chicago, IL 60604

T: (312) 600-5485

ccarter@daviscarterlaw.com

mdavis@daviscarterlaw.com

Counsel for Plaintiff



US00D978293S

(12) **United States Design Patent** (10) **Patent No.:** **US D978,293 S**
Yan (45) **Date of Patent:** **** Feb. 14, 2023**

(54) **FAUCET SET** D961,051 S * 8/2022 Zeng D23/241
 D961,053 S * 8/2022 Zhu D23/242
 D965,111 S * 9/2022 Kulig D23/242

(71) Applicant: **Meihua Yan**, Hong Kong (CN)

(72) Inventor: **Meihua Yan**, Hong Kong (CN)

(**) Term: **15 Years**

(21) Appl. No.: **29/785,806**

(22) Filed: **May 27, 2021**

(51) **LOC (14) Cl.** **23-01**

(52) **U.S. Cl.**
 USPC **D23/242**

(58) **Field of Classification Search**
 USPC D23/238-244, 252, 254-255, 257, 499;
 D7/398

CPC F16K 31/602; F16K 31/605; F16K 31/607;
 E03C 1/0412

See application file for complete search history.

(56) **References Cited**

U.S. PATENT DOCUMENTS

D517,655 S *	3/2006	Ogata	D23/241
D602,570 S *	10/2009	Lammel	D23/242
D767,727 S *	9/2016	Eads	D23/242
D797,246 S *	9/2017	Downey	D23/242
D809,630 S *	2/2018	Schoenherr	D23/242
D811,536 S *	2/2018	Schoenherr	D23/242
D828,506 S *	9/2018	Schoenherr	D23/238
D828,507 S *	9/2018	Schoenherr	D23/238
D848,575 S *	5/2019	Garland	D23/242
D856,490 S *	8/2019	Seum	D23/242
D861,136 S *	9/2019	Diefenbach	D23/242
D868,215 S *	11/2019	Chen	D23/242
D883,442 S *	5/2020	Massaud	D23/242
D898,872 S *	10/2020	Massaud	D23/242
D916,500 S *	4/2021	Johnson	D6/542
D924,369 S *	7/2021	Zeng	D23/242
D944,365 S *	2/2022	Lazarini	D23/242

FOREIGN PATENT DOCUMENTS

CA	166280	*	3/2017
CN	304953123	*	12/2018
IN	249374-0001	*	3/2014
WO	D093856-021	*	6/2017

OTHER PUBLICATIONS

KES Bathroom Sink Faucet , first available Apr. 22, 2021[online], [site visited Jul. 25, 2022]. Available from internet. URL:<https://www.amazon.com/dp/B0936S8NN2/?th=1> (Year: 2021)*

(Continued)

Primary Examiner — David G Muller
Assistant Examiner — Jamaal Rasheed
 (74) *Attorney, Agent, or Firm* — ScienBiziP, P.C.

(57) **CLAIM**

The ornamental design for a faucet set, as shown and described.

DESCRIPTION

FIG. 1 is a front, right, and top perspective view of a faucet set, showing my design.
 FIG. 2 is a front elevation view thereof.
 FIG. 3 is a rear elevation view thereof.
 FIG. 4 is a left side elevation view thereof.
 FIG. 5 is a right side elevation view thereof.
 FIG. 6 is a top plan view thereof; and,
 FIG. 7 is a bottom plan view thereof.
 The broken lines shown in the drawings are included for the purpose of illustrating portions of the faucet set that form no part of the claimed design.

1 Claim, 7 Drawing Sheets

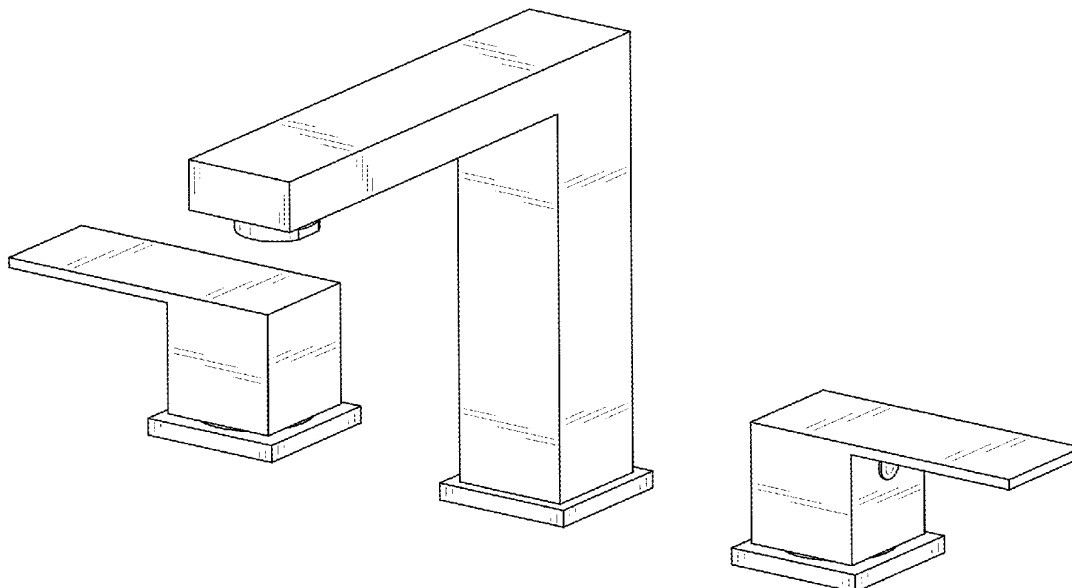

US D978,293 S

Page 2

(56)

References Cited

OTHER PUBLICATIONS

KENES Black Widespread Bathroom Faucet , first available Oct. 12, 2021 [online], [site visited Jul. 21, 2022], Available from internet, URL:< <https://www.amazon.com/dp/B09J83CJR7>> (Year: 2021).*

VCCUCINE Modern 2 Handle 3 Holes Solid Brass Matte Black Lavatory Vanity Sink Widespread Bathroom Faucet, Date first available Dec. 5, 2019[online], [site visited Jul. 23, 2022]. Available from internet, URL:< <https://www.amazon.com/VCCUCINE-Modern-Lavatory-Widespread-Bathroom/dp/B082CCRR43>> (Year: 2019).*

* cited by examiner

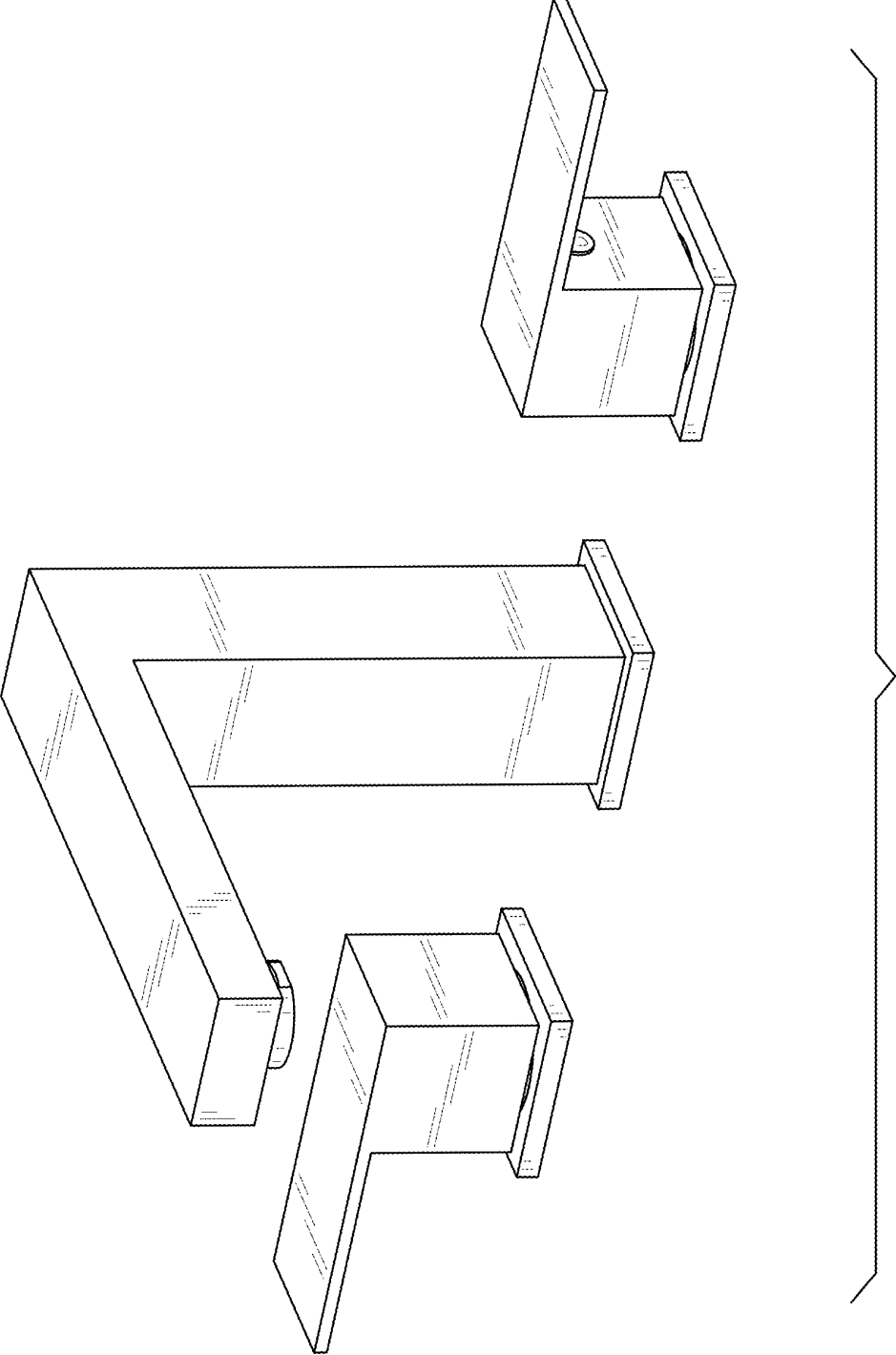
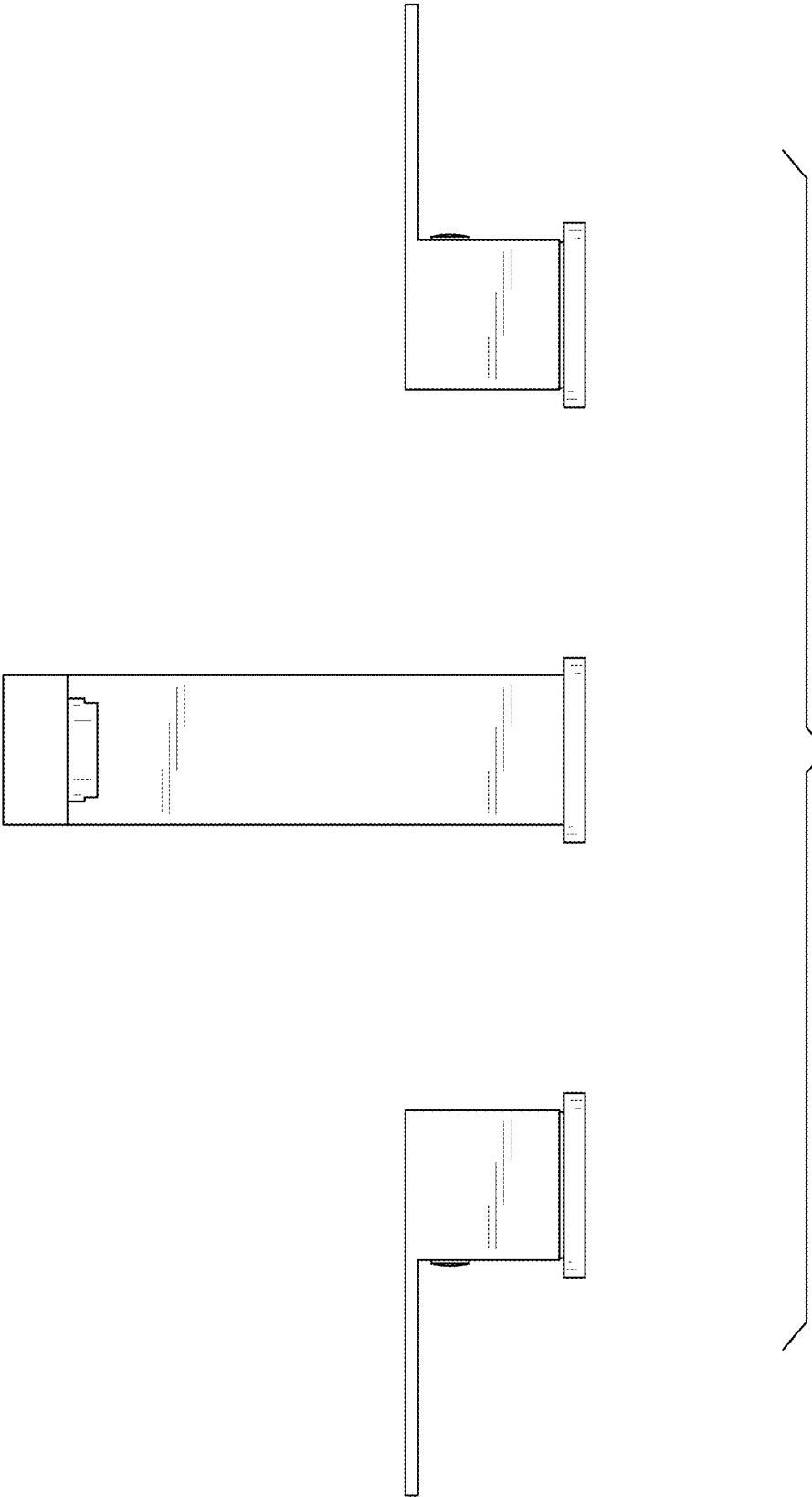

FIG. 1



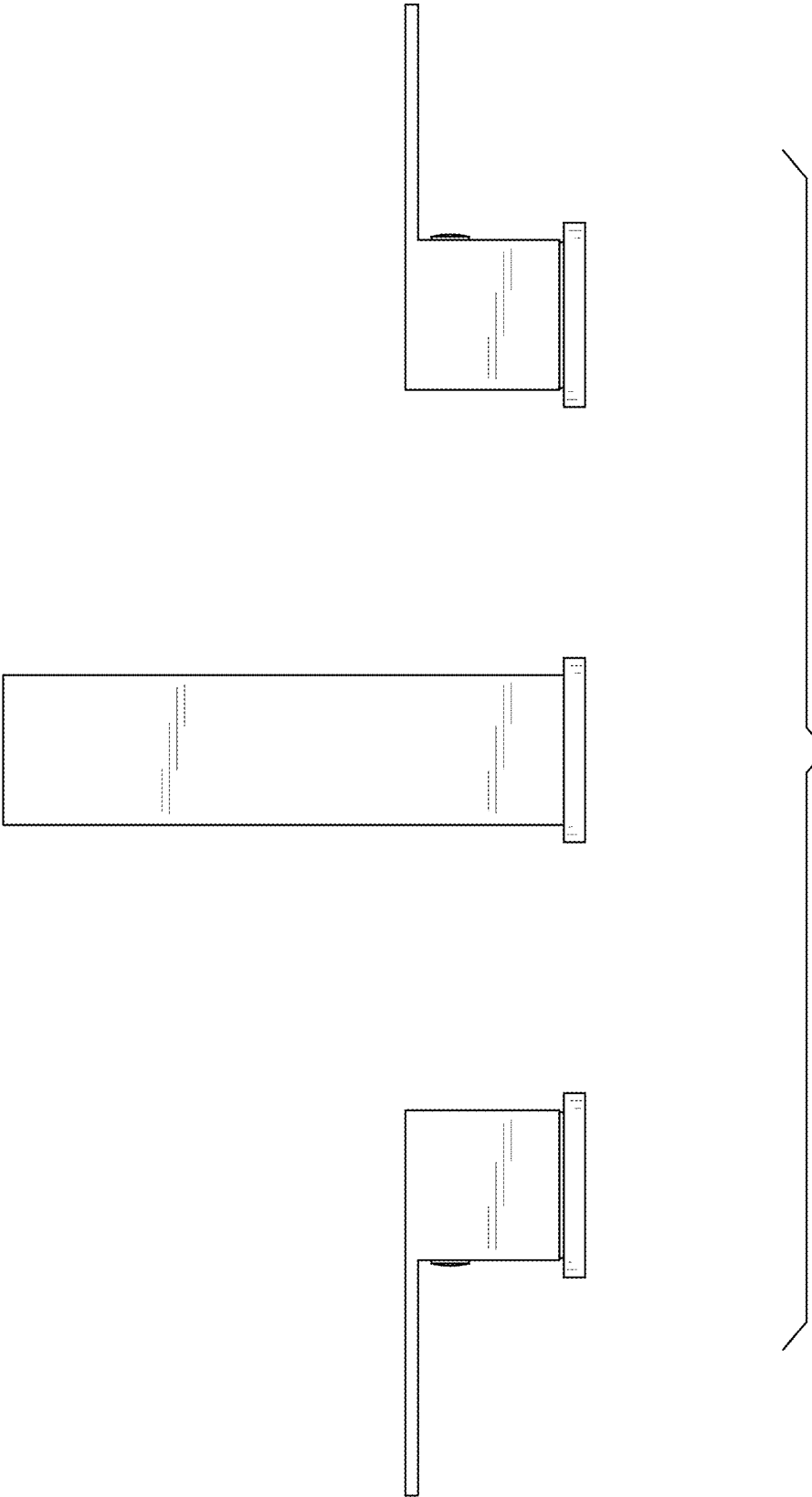

FIG. 3

U.S. Patent

Feb. 14, 2023

Sheet 4 of 7

US D978,293 S

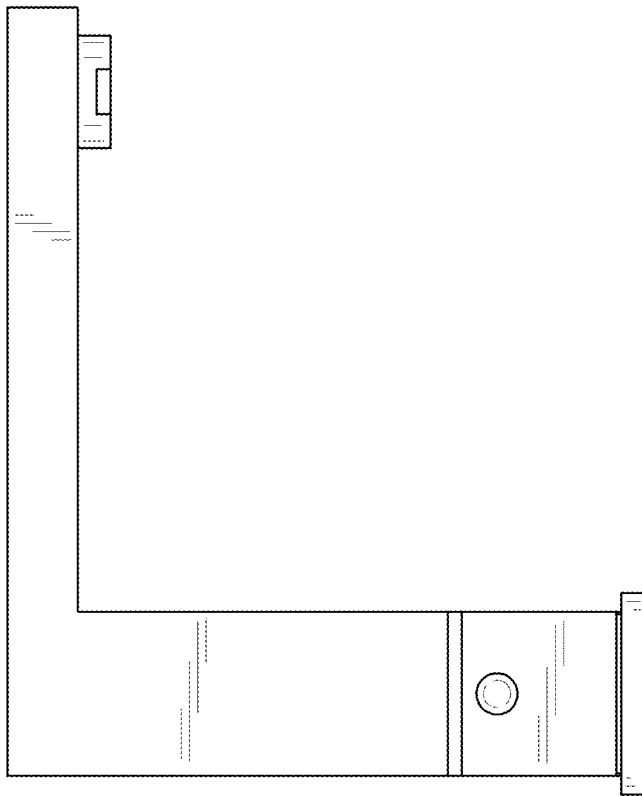

FIG. 4

U.S. Patent

Feb. 14, 2023

Sheet 5 of 7

US D978,293 S

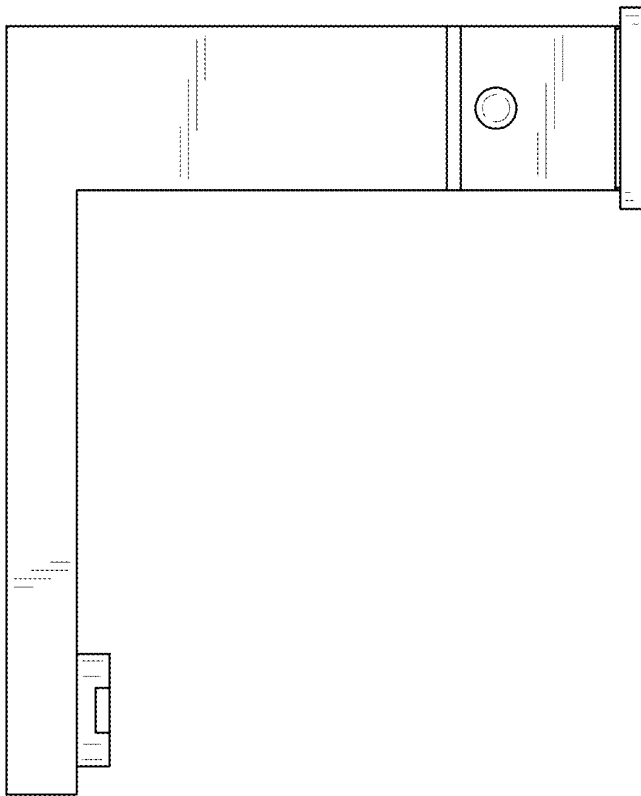

FIG. 5

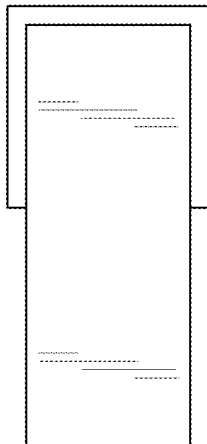
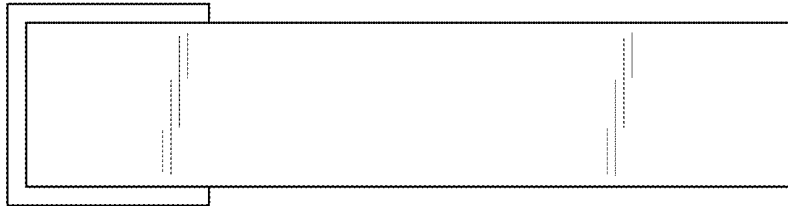
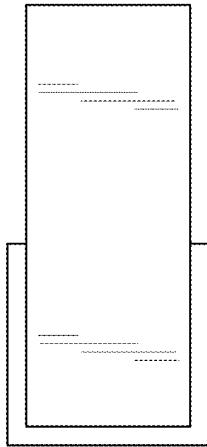

FIG. 6

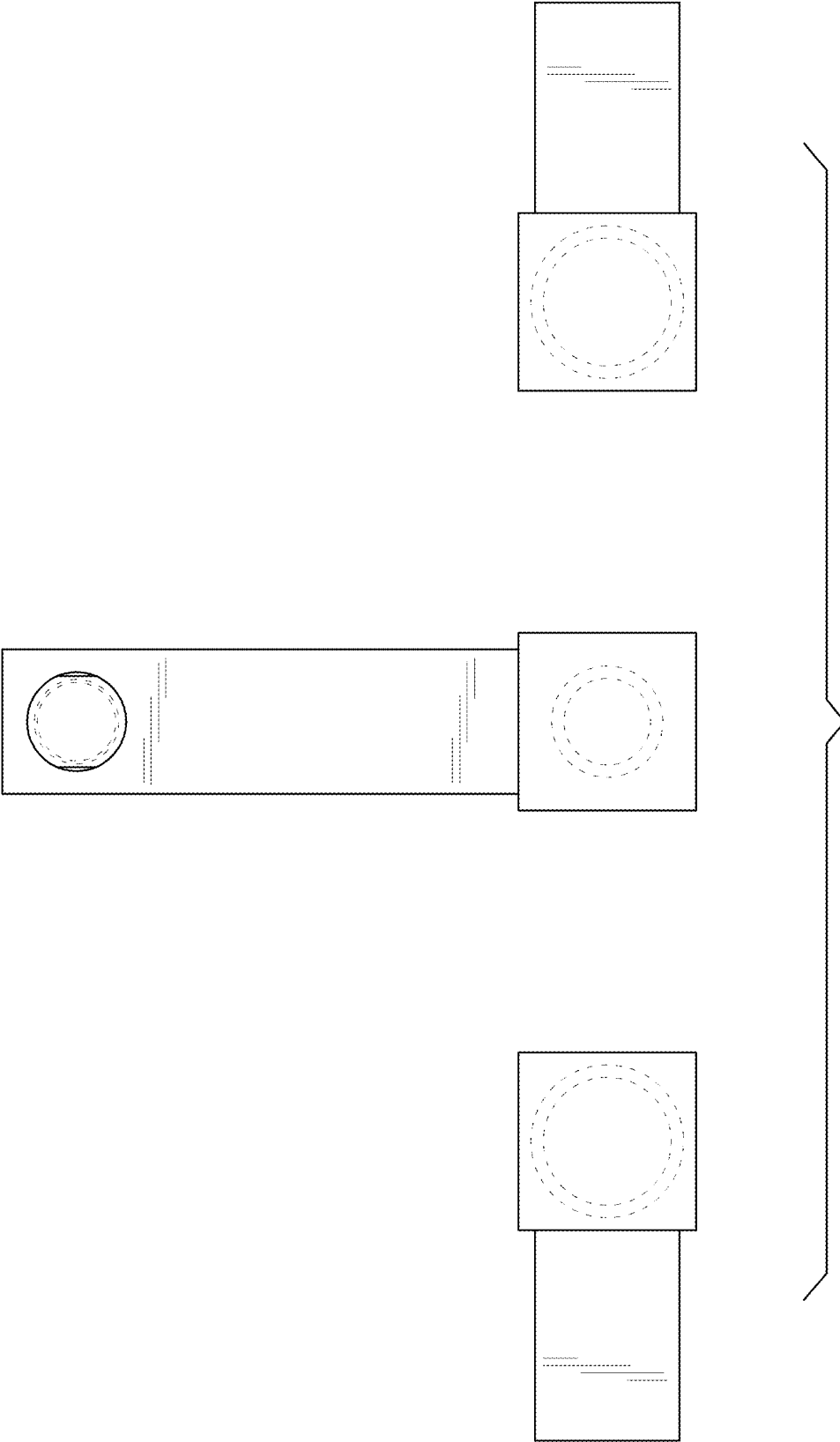

FIG. 7

**IN THE UNITED STATES DISTRICT COURT
FOR THE NORTHERN DISTRICT OF ILLINOIS
EASTERN DIVISION**

Meihua Yan,)	
)	
)	Case No. 1:24-cv-xxxx
v.)	
)	
The Individuals, Partnerships and Unincorporated Associations Identified on Schedule A,)	
)	
)	Defendants.

Schedule A

<u>Def. No.</u>	<u>Marketplace</u>	<u>Name</u>	<u>Seller ID</u>	<u>ASINs</u>
1	Amazon	FORIOUS-USA	A3UB46L7YYUHS1	B0C6LR 8JNP B0C6LN YNYQ B0C6LQ KTS5
2	Amazon	FORIOUS-USA	A3UB46L7YYUHS1	B0CJFHXYT B0CJFHWT5H B0CJFG5W4B
3	Amazon	JINCROP HOME	A3MJCEEMT23TK3	B0CGCLYB4S B0CGCRR4H3 B0CGCLXCSM
4	Amazon	BUHUILOU	A1DRGIVISODXNK	B08GJHJGHT B08GJH1ZQB B08GJH9SJP
5	Amazon	Bacui Bath	A2QOPHU46JFS28	B0C9PMSJCJ B0C9PP2ZXD
6	Amazon	Kenes official flagship store	A1CVTTXLZC3AC	B0C4P2CKPV B09J8CL5BY B09J8BMBZD B0CKR1T1B7 B0C3GVN1SQ B0C5XK4FPF

7	Amazon	BESy Bathroom & Kitchen	A3CENQWEZ1YS5 2	B0CNCSY89H B0CL9JXM54 B0C1GHP2SR B0CL9NDC31 B0C3VC41DS B0CJJ67SMS B0CJJ66Y8J B0BGK64R5L B0BGK7DR99 B0BGK6YDZ5 B09JB9SWP1 B0CGV6LGFB B0CN2DGDQC B0CN2B7KZT B0CN1ZQNB7 B0CGV54CFG
8	Amazon	Likefaucet	A1GC1QWWE31PV 2	B0C65CL6GK B0C657F3V1
9	Amazon	sumerain	A1DVNRQGJ9K9C W	B0BWS1LQMQ B0C468SW4C B0BWRZZ4QX B0BWS128WJ B0CCNTTH4J B0C4H66Z7K B0C4H7B146 B0CC96XTFG B0CCNJQMXJ B08GJHJGHT B0C55FDP84 B0CC97WH2H B0CC99QBLN B0CCNH3B3V
10	Amazon	Hamoler	A1N540EHWTF1B	B0C594DND8 B0C556H24L
11	Amazon	CEINOL-USA	A2LE5H9GP8P771	B0BNYN5Z49 B0BNYNLCGM B0BNYMM9ZP B0C482RXW4 B0BNYMGPL5 B0BNYMF16L

12	Amazon	HOIMPRO	A2L670C1R6EMKB	B0BB2CDX8G B0C9MJ3GQ4 B0CBTVLKVN B0C6XB22V9 B0C85B4DWP
13	Amazon	FELIXBATH	A31HP04U69ZF8W	B0CQYMGVH5 B0BDRJ95WF
14	Amazon	BWE Aqua Faucet	A35JW824RMRZQ9	B095RZ7N7R B09XT221VV B09MVRQ148
15	Amazon	Taucent	A2Z1FDMLJDZE5V	B0BKG3VNGH B0BKG5K687
16	Amazon	BATHLAVISH	A31J76NPUK0FO1	B0B387XL19 B0C779CTY2 B0C5SPV4HY B0CHW16YCH B0CJR3PXW5
17	Amazon	BATHLAVISH	A31J76NPUK0FO1	B09LGXXXJW? B0BL792X4Q B0BLJZYFT B0BLJZYFT B0BLG7P915 B0CHVZJ2D2
18	Amazon	RUMOSE	A5PJSI95M0FZO	B0C52WY8RV B0C52RH8JL B0C52W6D26 B0B71943R9 B0C531D1XG
19	Amazon	SeeTruth	A17IDSPKLXED0C	B0CQ1ZT3SZ
20	Amazon	Bathfinesse faucet	AIR0928KHM5DG	B0B387ZL19

21	Amazon	Greenspring	A266OR1KH3COD O	B0B3WPP6YV B0BHS5TJ6X
22	Amazon	Cfeorf	A304ANM74GSKY9	B0C53GJZVB
23	Wayfair	BESy	besy-b71323	B_BTOF_00004_01_BK_ PU_LF
24	Wayfair	FORIOUS	forious-b59142	WB-03033BN WB-03033B WB-03033G WB-03033CH
25	Wayfair	Homary	homary-b58154	wf-J020925-BG
26	Wayfair	Modern Space	modern-space- b61779	MS0727 MS0956
27	Wayfair	Plumbing N Parts	plumbing-n-parts- b76333	PNP-36107
28	Wayfair	RBROHANT	rbrohant-b57720	JK0008 JK0009
29	Wayfair	RBROHANT	rbrohant-b57720	RBF65011MB RB0956BGUS JK0012 JK0013
30	Wayfair	TAPLONG	tl-b65821	TLK0012BN TL0956BG TL0727MB-1 TLK0013PC
31	Wayfair	TAPLONG	tl-b65821	TLK0008MB TLK0009BG
32	Wayfair	VIBRANTBATH	vibrantbath-b51837	16439-BG 16439 16439-N 16439