

1
2
3
4
5
6
7
8
9
10
11
12
13
14
15
16
17
18
19
20
21
22
23
24
25
26
27
28

UNITED STATES DISTRICT COURT
FOR THE WESTERN DISTRICT OF WASHINGTON
AT SEATTLE

PUMA SE, and PUMA North America Inc.,) Case No.
)
Plaintiffs,)
)
v.)
)
Brooks Sports, Inc.,) JURY DEMAND
)
Defendant.)

COMPLAINT FOR PATENT INFRINGEMENT

Plaintiffs, PUMA SE and PUMA North America Inc. (collectively, “PUMA”), by and through undersigned counsel, bring this action for patent infringement against Defendant Brooks Sports, Inc. (“Brooks”), and by and for their Complaint, allege as follows:

NATURE OF THE ACTION

1. This is an action for patent infringement seeking to remedy Brooks’ ongoing disregard for PUMA’s intellectual property rights through the manufacture, use, sale, offer for sale and importation of athletic shoes that infringe PUMA’s patents. Indeed, Brooks’ infringing activity has continued even after PUMA provided notice to Brooks of at least PUMA’s U.S. Patent Number 11,825,904 to Brooks’ VP Legal & General Counsel. This action seeks a permanent injunction and the recovery of monetary damages stemming from Brooks’ infringement of nine of PUMA’s patents, specifically United States Patent Nos. 11,825,904 (“the ’904 Patent”), 11,974,629 (“the ’629 Patent”), 11,974,630 (“the ’630 Patent”), 12,016,422 (“the ’422 Patent”), D1,022,421 (“the D’421 Patent”), D1,022,422 (“the D’422 Patent”), D1,023,531 (“the D’531 Patent”), D1,021,356 (“the D’356 Patent”), and D1,009,432 (“the D’432 Patent”) (collectively, “the Asserted Patents”).

COMPLAINT

PARTIES

2. Plaintiffs PUMA SE and PUMA North America Inc. are world leaders in the sportswear industry.

3. PUMA SE is organized and existing under the laws of Germany, with its principal place of business at Puma Way 1, 91074 Herzogenaurach, Germany. PUMA SE is a multinational company that designs and manufactures athletic and casual footwear, apparel, and accessories. PUMA SE employs more than 20,000 people worldwide and distributes its products in more than 120 countries, with over 9.3 Billion dollars in sales in 2023.

4. PUMA North America Inc. is a Delaware corporation with its principal place of business at 455 Grand Union Blvd, Somerville, MA 02145.

5. PUMA North America directs all U.S.-based operations on behalf of PUMA SE, including sales, brand marketing, product marketing, product design, public relations, distribution, enforcement, and licensing of and for PUMA-branded merchandise.

6. PUMA North America is a licensee of patents owned by PUMA SE for purposes of PUMA North America's U.S. sales activities.

7. Defendant Brooks Sports, Inc. is a Washington corporation, with its principal place of business at 3400 Stone Way N, Suite 500, Seattle, WA 98103.

JURISDICTION AND VENUE

8. This is an action for patent infringement under the patent laws of the United States, namely, 35 U.S.C. §§ 101 et seq., 271, 281, and 284, among others. This Court has original subject matter jurisdiction over this dispute pursuant to 28 U.S.C. §§ 1331 and 1338(a).

9. This Court has general personal jurisdiction over Brooks because it is a Washington corporation with its principal place of business in Seattle, Washington.

10. Venue is also proper in this district pursuant to 28 U.S.C. § 1400(b) because Brooks has committed acts of patent infringement in this district and its principal place of business in this district, located in Seattle, Washington.

FACTS AND BACKGROUND

1
2 11. PUMA has a long, storied history in the running industry, and specifically in the
3 development of track and field spikes and running shoes.

4 12. While operating as Dassler Brothers Shoe Factory, a predecessor to PUMA, the
5 original founding Dassler Brothers drove from Bavaria to the 1936 Summer Olympics in Berlin
6 with a suitcase full of track and field running spikes and persuaded United States sprinter Jesse
7 Owens to use them. Owens won four gold medals in the Dassler track and field spikes.

8 13. In 1948, the brothers split the business, and what is today PUMA was formed.

9 14. Since 1948, PUMA has drawn strength and credibility from its heritage in sports
10 and has continued its legacy of innovation, repeatedly designing shoes worn by track and field
11 gold medal Olympic athletes.

12 15. PUMA’s innovation continues through today.





13 16. In February of 2024, PUMA running shoes were worn by the first and third place
14 runners in the women’s Olympic Trials Marathon, setting a women’s Olympic Trials record.

15 17. PUMA’s innovation has been possible due to PUMA’s continued investment in
16 research, development and design efforts, striving to make PUMA’s athletes forever faster.

17 18. To protect its investment in innovation, PUMA seeks patent protection for its
18 unique contributions to the running space, having obtained both utility and design patents on its
19 running shoes and track spikes.



20 19. Plaintiff PUMA SE is the owner by assignment of the entire right, title, and
21 interest in the ’904 Patent. A true and correct copy of the ’904 Patent is attached hereto as Exhibit
22 A.



23 20. After the priority date of the ’904 Patent, Brooks introduced a shoe, the “Hyperion
24 Elite MD,” that infringes at least Claim 14 of the ’904 Patent. As shown below, the Hyperion
25 Elite MD meets every limitation of Claim 14 of the ’904 Patent.

'904 Patent, Claim 14	Hyperion Elite MD
<p>1 A sole structure for an article of footwear 2 having an upper, the sole structure 3 comprising:</p>	
<p>4 5 6 7 8 a first cushioning member;</p>	
<p>9 10 11 12 13 14 a second cushioning member that is spaced 15 apart from the first cushioning member by a 16 gap that extends between the first cushioning 17 member and the second cushioning member; 18 and</p>	
<p>19 20 a sole plate that extends across the gap from 21 the first cushioning member to the second 22 cushioning member, the sole plate extending 23 away from the upper moving across the gap 24 from the first cushioning member to the 25 second cushioning member, wherein the sole 26 plate is positioned within at least one of the 27 first cushioning member and the second 28 cushioning member.</p>	

1 21. Plaintiff PUMA SE is the owner by assignment of the entire right, title, and
 2 interest in the '629 Patent. A true and correct copy of the '629 Patent is attached hereto as Exhibit
 3 B.



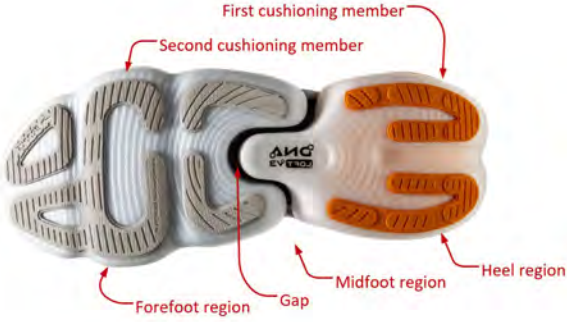
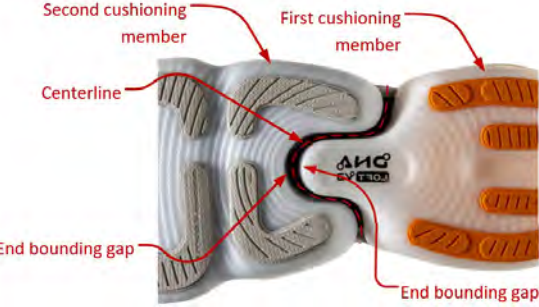

4 22. After the priority date of the '629 Patent, Brooks introduced a shoe, the "Aurora-
 5 BL," that infringes at least Claim 1 of the '629 Patent. As shown below, the Aurora-BL meets
 6 every limitation of Claim 1 of the '629 Patent.





'629 Patent, Claim 1	Aurora-BL
<p>7 An article of footwear having a sole structure 8 and an upper, the sole structure comprising:</p>	
<p>9 a first cushioning member directly coupled to 10 the upper and extending continuously between 11 a heel region and a midfoot region of the sole 12 structure; and</p>	
<p>13 a second cushioning member directly coupled 14 to the upper and extending continuously 15 between a forefoot region and the midfoot 16 region of the sole structure,</p>	

'629 Patent, Claim 1	Aurora-BL
<p>1 wherein the first cushioning member and the 2 second cushioning member overlap in the 3 midfoot region and are spaced apart to define 4 a gap that extends between the first 5 cushioning member and the second 6 cushioning member in the midfoot region of the sole structure,</p>	
<p>7 the gap having a centerline defined between 8 the first cushioning member and the second 9 cushioning member, the centerline following a 10 contour of an end of at least one of the first 11 cushioning member and the second 12 cushioning member that bounds the gap when viewed from a bottom of the article of footwear;</p>	
<p>13 and wherein at least one of the first cushioning 14 member or the second cushioning member are a supercritical foam.</p>	<p>DEFY GRAVITY</p> <p>Supreme softness</p> <p>Nitrogen-injected DNA LOFT v3 cushioning makes for softer, lighter, more responsive landings.</p> <ul style="list-style-type: none"> ○ This new technique makes DNA LOFT v3 our lightest, softest, most responsive version yet. ○ We also used a “large-cell foaming” process which amplifies the softness & energy return without sacrificing durability. 

1 23. Plaintiff PUMA SE is the owner by assignment of the entire right, title, and
 2 interest in the '630 Patent. A true and correct copy of the '630 Patent is attached hereto as Exhibit
 3 C.

4 24. After the priority date of the '630 Patent, Brooks introduced a shoe, the "Hyperion
 5 Elite LD," that infringes at least Claim 15 of the '630 Patent. As shown below, the Hyperion
 6 Elite LD meets every limitation of Claim 15 of the '630 Patent.

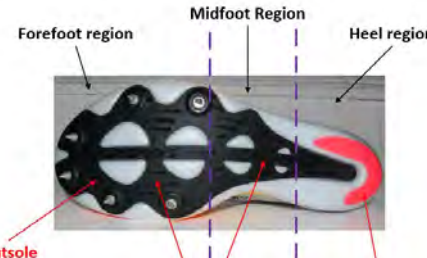
'630 Patent, Claim 15	Hyperion Elite LD
An article of footwear comprising:	<p data-bbox="938 625 1117 653">Article of footwear</p> 
an upper; and	<p data-bbox="927 968 1105 995">Article of footwear</p> <p data-bbox="1386 957 1451 984">Upper</p> 
a sole structure coupled to the upper and defining a ground engaging surface,	<p data-bbox="1386 1283 1451 1310">Upper</p>  <p data-bbox="932 1514 1143 1541">Ground engaging surface</p> <p data-bbox="1338 1509 1468 1537">Sole structure</p>
the sole structure including: a cushioning member coupled to the upper; and	<p data-bbox="1370 1562 1451 1589">Upper</p>  <p data-bbox="935 1850 1146 1877">Cushioning Member</p> <p data-bbox="1321 1839 1468 1866">Sole structure</p>



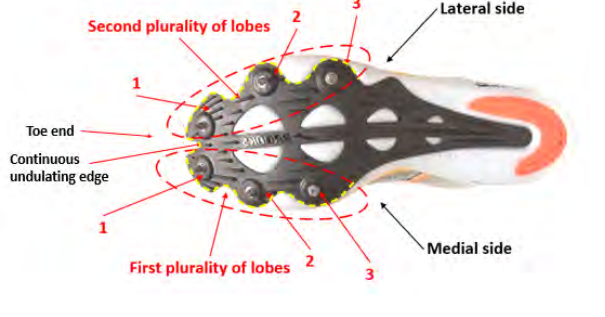
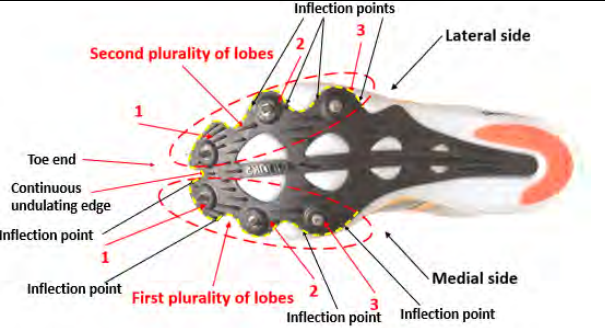

'630 Patent, Claim 15	Hyperion Elite LD
<p>1 an outsole coupled to the cushioning member,</p> <p>2</p> <p>3</p> <p>4</p> <p>5</p> <p>6</p>	 <p>Cushioning Member Outsole</p>
<p>7 the outsole including a front outsole segment</p> <p>8 positioned in a forefoot region and a midfoot</p> <p>9 region, and</p> <p>10</p> <p>11</p> <p>12</p> <p>13</p>	 <p>Forefoot region Midfoot Region Heel region</p> <p>Outsole</p> <p>Front outsole segment</p>
<p>14 a rear outsole segment positioned in a heel</p> <p>15 region and discontinuous with the front</p> <p>16 outsole segment along the ground engaging</p> <p>17 surface,</p> <p>18</p> <p>19</p> <p>20</p>	 <p>Forefoot region Midfoot Region Heel region</p> <p>Outsole</p> <p>Front outsole segment Rear outsole segment</p>
<p>21 the front outsole segment including a medial</p> <p>22 segment with a first plurality of lobes</p> <p>23 arranged along a medial side of the sole</p> <p>24 structure and a lateral segment with a second</p> <p>25 plurality of lobes arranged along a lateral</p> <p>26 side of the sole structure,</p> <p>27</p> <p>28</p>	 <p>Second plurality of lobes</p> <p>Lateral segment</p> <p>Medial segment</p> <p>First plurality of lobes</p> <p>Front outsole segment</p>

'630 Patent, Claim 15	Hyperion Elite LD
<p>1 wherein each of the first plurality of lobes and 2 the second plurality of lobes includes at least 3 two lobes that are disposed entirely within the 4 forefoot region such that the outsole has a 5 continuous undulating peripheral edge 6 extending around a toe end of the sole structure from a lateral side to a medial side, and</p>	 <p>The diagram shows a top-down view of the sole structure. A dashed red line outlines a 'Continuous undulating edge' that runs from the 'Toe end' on the left to the 'Medial side' on the right. Two groups of lobes are shown: the 'First plurality of lobes' (labeled 1) and the 'Second plurality of lobes' (labeled 2). Three specific lobes are numbered 1, 2, and 3. The 'Lateral side' is on the left and the 'Medial side' is on the right.</p>
<p>7 wherein the undulating peripheral edge 8 defines at least four inflection points along the 9 lateral side and at least four inflection points 10 along the medial side within the forefoot 11 region and the midfoot region.</p>	 <p>This diagram is similar to the one above but highlights 'Inflection points' with arrows. There are four inflection points on the lateral side and four on the medial side, all within the forefoot and midfoot regions. The other labels (Toe end, Continuous undulating edge, Lobes, Lateral side, Medial side) are also present.</p>

12 25. Plaintiff PUMA SE is the owner by assignment of the entire right, title, and
 13 interest in the '422 Patent. A true and correct copy of the '422 Patent is attached hereto as Exhibit
 14 D.

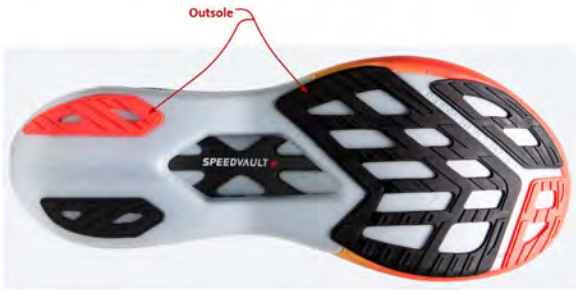

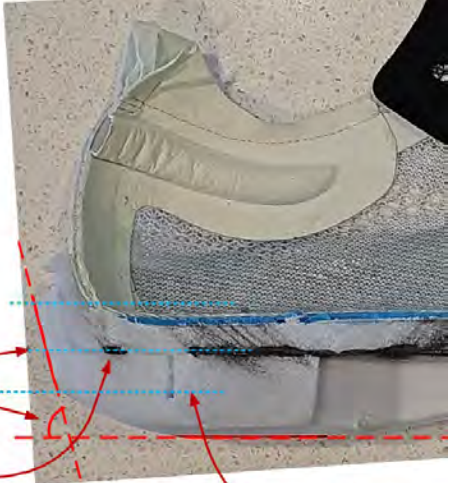

15 26. After the priority date of the '422 Patent, Brooks introduced a shoe, the "Hyperion
 16 Elite 4," that infringes at least Claim 9 of the '422 Patent. As shown below, the Hyperion Elite 4
 17 meets every limitation of Claim 9 of the '422 Patent.

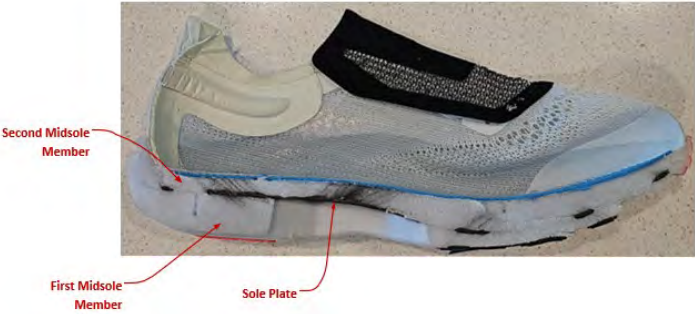
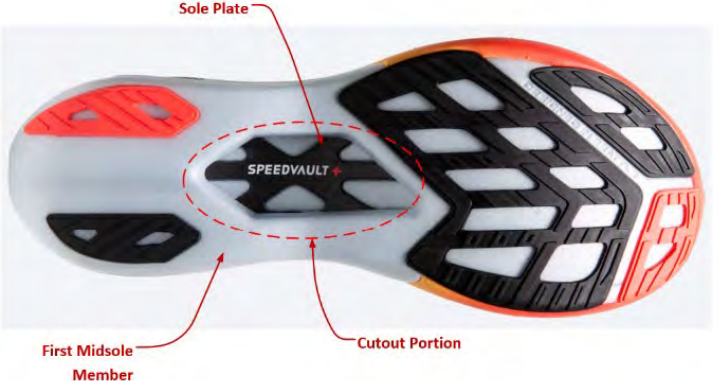
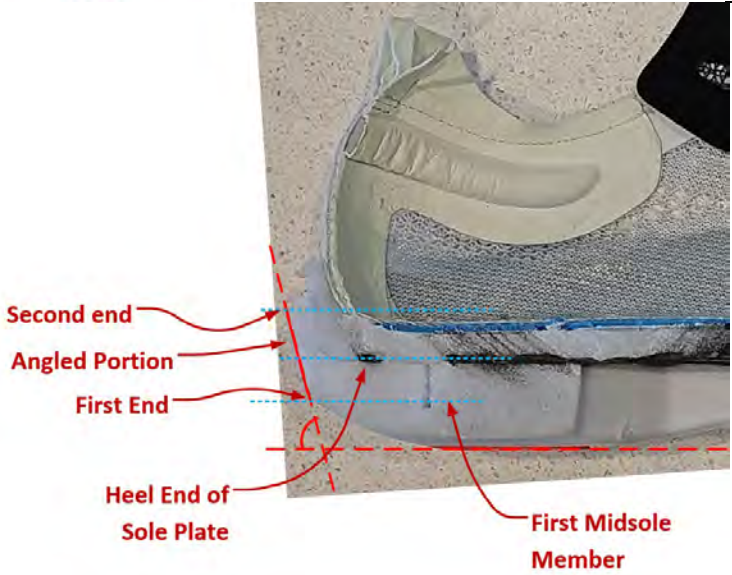
'422 Patent, Claim 9	Hyperion Elite 4
<p>19 A sole structure for an article of footwear having an upper, the 20 sole structure comprising:</p>	 <p>The image shows a side view of a Brooks Hyperion Elite 4 running shoe. Red arrows point to the 'Article of Footwear' (the entire shoe), the 'Upper' (the top part of the shoe), and the 'Sole Structure' (the bottom part of the shoe).</p>

'422 Patent, Claim 9	Hyperion Elite 4
<p>1 an outsole;</p> <p>2</p> <p>3</p> <p>4</p> <p>5</p> <p>6</p>	 <p>Outsole</p>
<p>7 a midsole extending between the</p> <p>8 outsole and the upper, the</p> <p>9 midsole including a first midsole</p> <p>10 member coupled to the outsole</p> <p>11 and extending from a forefoot</p> <p>12 region to a heel region of the sole</p> <p>13 structure,</p>	 <p>Upper</p> <p>Second Midsole Member</p> <p>Heel Region</p> <p>First Midsole Member</p> <p>Outsole</p> <p>Midsole</p> <p>Forefoot Region</p>
<p>14 the first midsole member</p> <p>15 defining an entry region at a heel</p> <p>16 end in which the first midsole</p> <p>17 member defines a substantially</p> <p>18 flat angled portion that is angled</p> <p>19 away from a ground surface by a</p> <p>20 first angle that is configured to</p> <p>21 increase contact at a ground</p> <p>22 engaging surface of the first</p> <p>23 midsole member during a heel</p> <p>24 strike, and</p>	 <p>Angled Portion</p> <p>First angle</p> <p>Heel End of Sole Plate</p> <p>First Midsole Member</p>
<p>25 a second midsole member</p> <p>26 coupled to the upper and</p> <p>27 positioned between the first</p> <p>28 midsole member and the upper,</p> <p>the second midsole member</p> <p>extending from the heel region to</p> <p>the forefoot region; and</p>	 <p>Upper</p> <p>Second Midsole Member</p> <p>First Midsole Member</p>

'422 Patent, Claim 9	Hyperion Elite 4
<p>1 a sole plate positioned within the 2 midsole between the first midsole 3 member and the second midsole 4 member,</p>	
<p>7 the sole plate being exposed at a 8 cutout portion in the first midsole 9 member,</p>	
<p>13 wherein the substantially flat 14 angled portion of the entry region 15 extends from a first end to a 16 second end, the first end being 17 positioned below a heel end of 18 the sole plate and the second end 19 being positioned above the heel 20 end of the sole plate.</p>	

23 27. After the priority date of the '422 Patent, Brooks introduced a shoe, the "Hyperion
24 Max 2," that infringes at least Claim 9 of the '422 Patent. As shown below, the Hyperion Max 2
25 meets every limitation of Claim 9 of the '422 Patent.







'422 Patent, Claim 9	Hyperion Max 2
<p>1 A sole structure for an article of 2 footwear having an upper, the 3 sole structure comprising: 4 5 6 7</p>	
<p>8 9 an outsole;</p>	
<p>10 11 12 13 14 15 a midsole extending between the 16 outsole and the upper, the midsole 17 including a first midsole member 18 coupled to the outsole and 19 extending from a forefoot region 20 to a heel region of the sole 21 structure,</p>	
<p>22 the first midsole member defining 23 an entry region at a heel end in 24 which the first midsole member 25 defines a substantially flat angled 26 portion that is angled away from a 27 ground surface by a first angle 28 that is configured to increase contact at a ground engaging surface of the first midsole member during a heel strike, and</p>	

'422 Patent, Claim 9	Hyperion Max 2
<p>1 a second midsole member 2 coupled to the upper and 3 positioned between the first 4 midsole member and the upper, 5 the second midsole member extending from the heel region to the forefoot region; and</p>	 <p>This diagram shows a side cross-section of a shoe. Labels include: Upper (pointing to the top part), Second Midsole Member (pointing to a red layer), Heel Region (pointing to the back part), First Midsole Member (pointing to a blue layer), and Forefoot Region (pointing to the front part).</p>
<p>6 a sole plate positioned within the 7 midsole between the first midsole 8 member and the second midsole 9 member,</p>	 <p>This diagram shows a side cross-section of a shoe. Labels include: Second Midsole Member (pointing to a red layer), First Midsole Member (pointing to a blue layer), and Sole Plate (pointing to a thin layer between the two midsole members).</p>
<p>11 the sole plate being exposed at a 12 cutout portion in the first midsole 13 member,</p>	 <p>This diagram shows a top-down view of the sole components. Labels include: Sole Plate (pointing to a red plate), First Midsole Member (pointing to a red layer with a cutout), and Cutout Portion (pointing to the hole in the first midsole member).</p>
<p>17 wherein the substantially flat 18 angled portion of the entry region 19 extends from a first end to a 20 second end, the first end being 21 positioned below a heel end of the sole plate and the second end 22 being positioned above the heel 23 end of the sole plate.</p>	 <p>This block contains two diagrams. The top diagram is a side view of a shoe with labels: Entry Region, Second End, Angled Portion, First End, and Heel. The bottom diagram is a cross-section of the shoe with a label: Heel End of Sole Plate.</p>

1 28. Plaintiff PUMA SE is the owner by assignment of the entire right, title, and
 2 interest in the D'421 Patent. A true and correct copy of the D'421 Patent is attached hereto as
 3 Exhibit E.

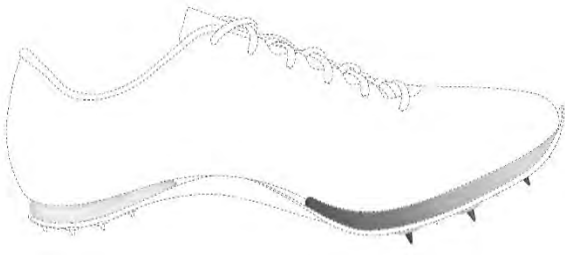
4 29. After the priority date of the D'421 Patent, Brooks introduced the Hyperion Elite
 5 MD.

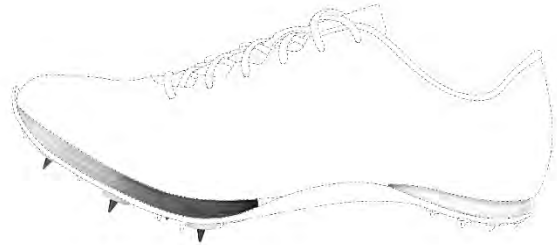
6 30. The Hyperion Elite MD infringes the D'421 Patent. As shown below, the
 7 Hyperion Elite MD meets every limitation of the D'421 Patent.

U.S. D1,022,421	Hyperion Elite MD
 <p data-bbox="584 1050 633 1071">FIG. 1</p>	
 <p data-bbox="592 1386 641 1407">FIG. 2</p>	
 <p data-bbox="592 1722 641 1743">FIG. 3</p>	

1
2
3
4
5
6
7
8
9
10
11
12
13
14
15
16
17
18
19
20
21
22
23
24
25
26
27
28

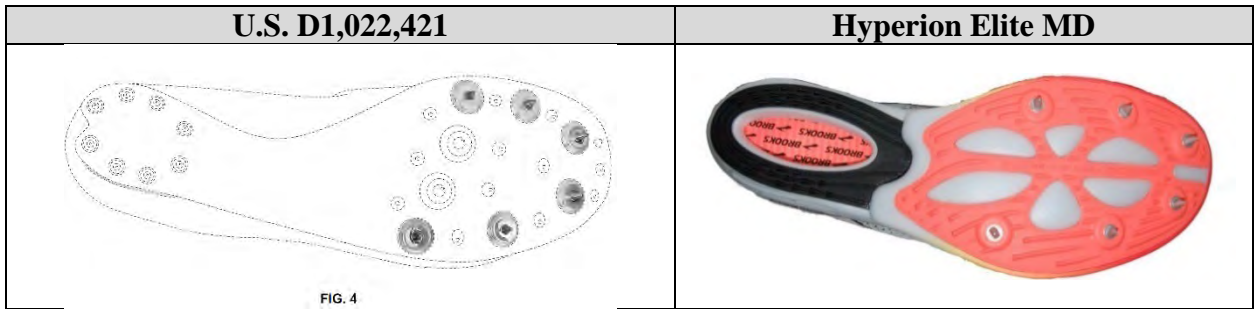

31. After the priority date of the D'421 Patent, Brooks introduced the Hyperion Elite LD.

32. The Hyperion Elite LD infringes the D'421 Patent. As shown below, the Hyperion Elite LD meets every limitation of the D'421 Patent.

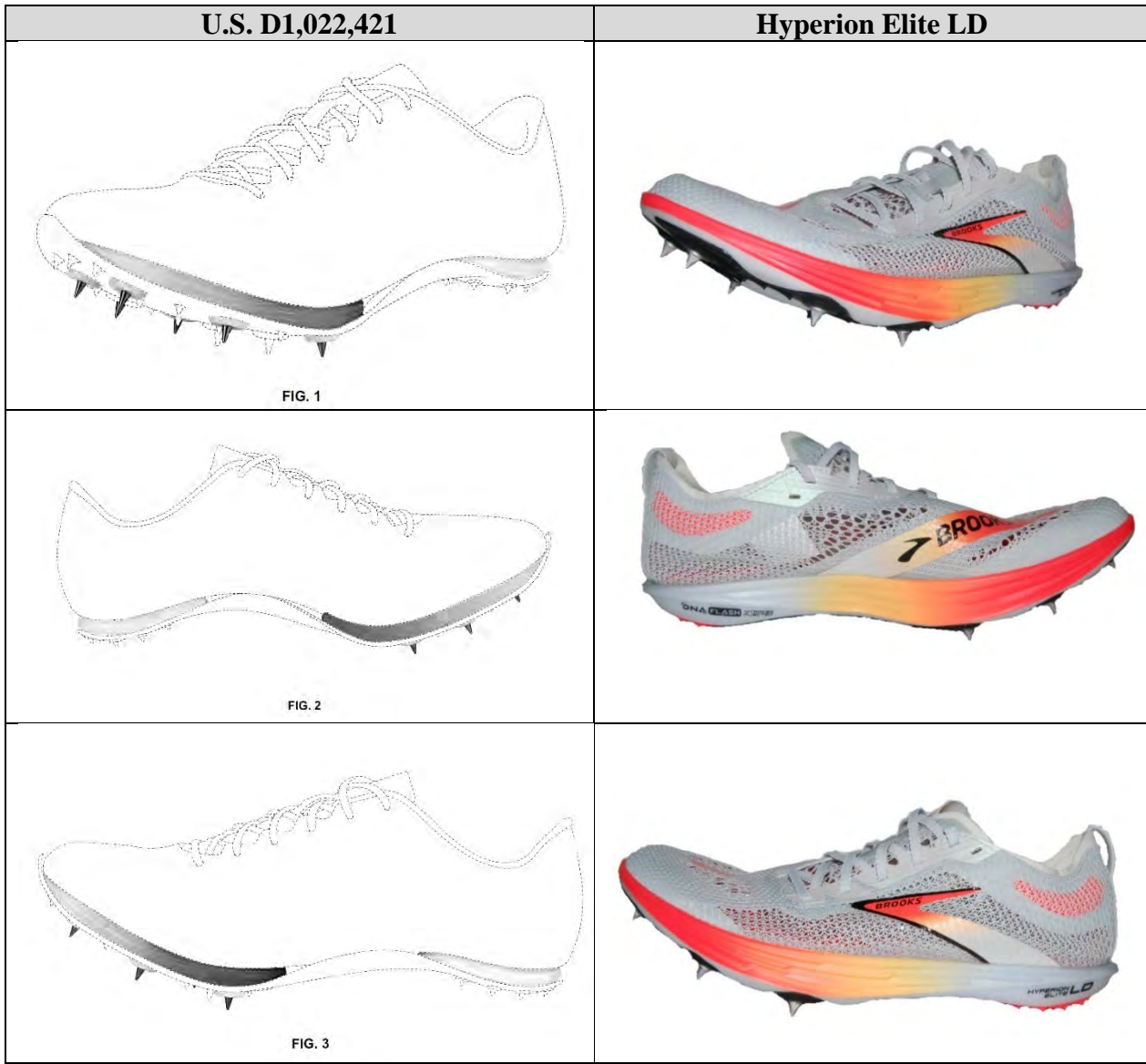

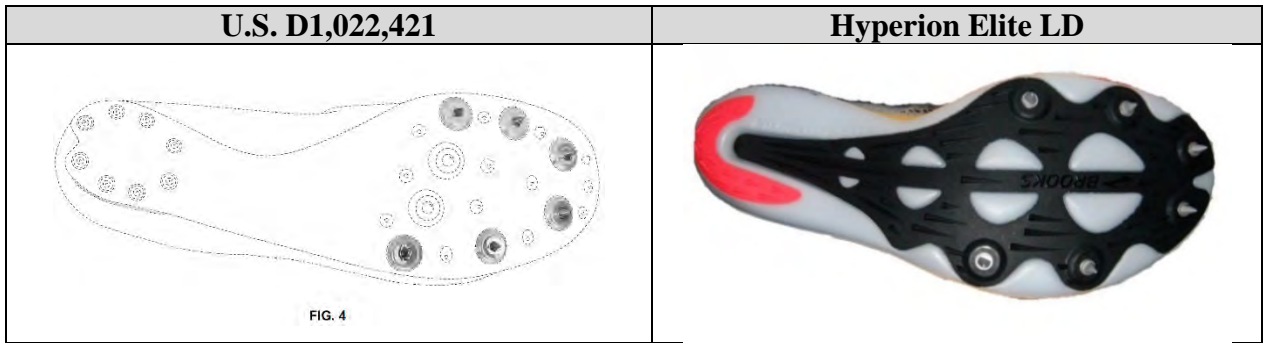

33. Plaintiff PUMA SE is the owner by assignment of the entire right, title, and interest in the D'422 Patent. A true and correct copy of the D'422 Patent is attached hereto as Exhibit F.

34. After the priority date of the D'422 Patent, Brooks introduced the Hyperion Elite MD.

35. The Hyperion Elite MD infringes the D'422 Patent. As shown below, the Hyperion Elite MD meets every limitation of the D'422 Patent.



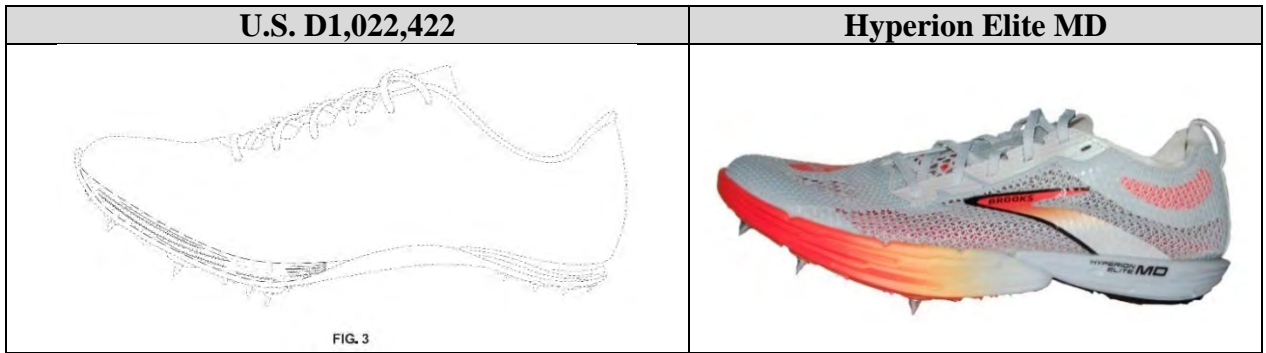

36. After the priority date of the D'422 Patent, Brooks introduced the Hyperion Elite LD.

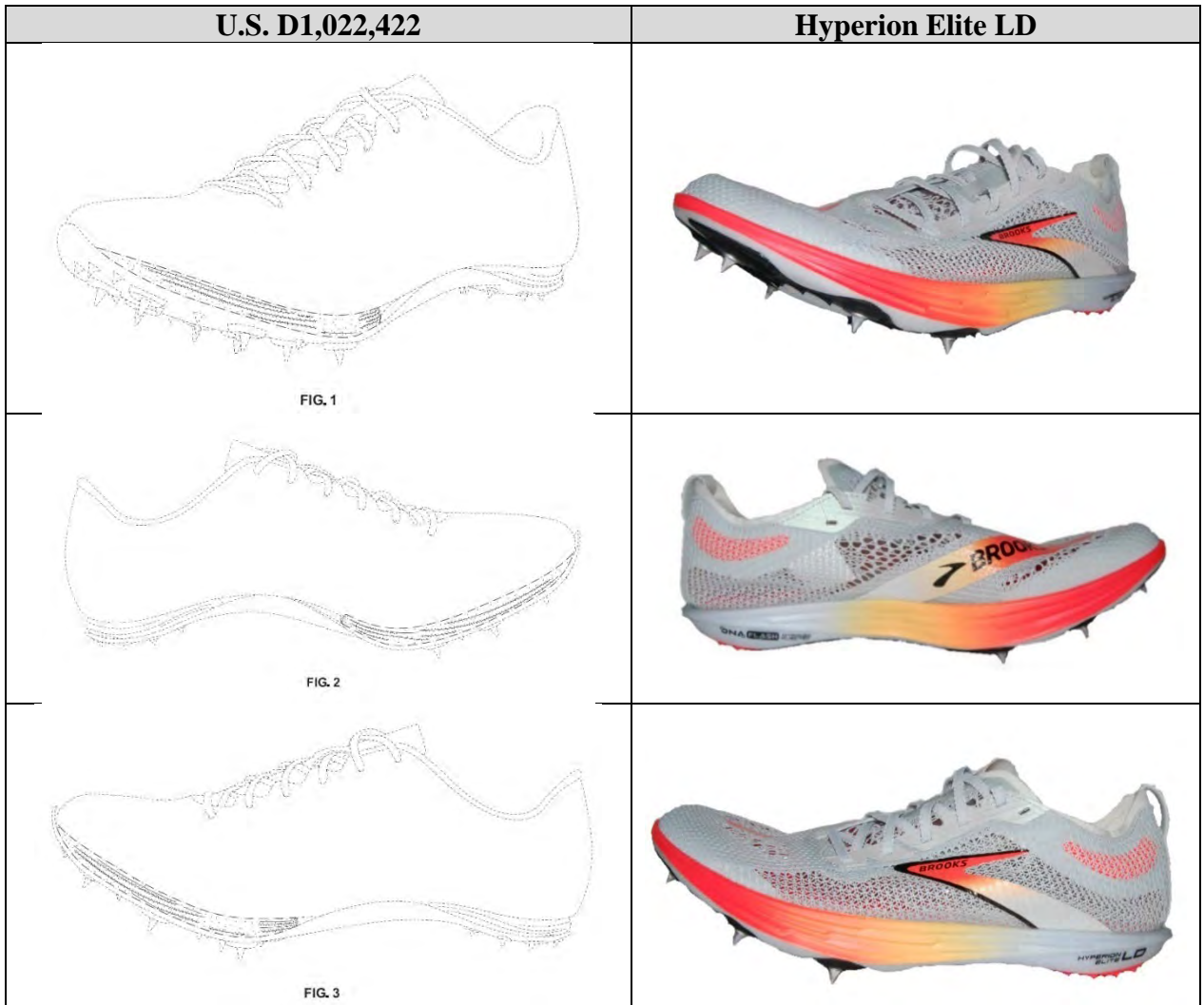

37. The Hyperion Elite LD infringes the D'422 Patent. As shown below, the Hyperion Elite LD meets every limitation of the D'422 Patent.



1 38. Plaintiff PUMA SE is the owner by assignment of the entire right, title, and
 2 interest in the D'531 Patent. A true and correct copy of the '531 Patent is attached hereto as
 3 Exhibit G.





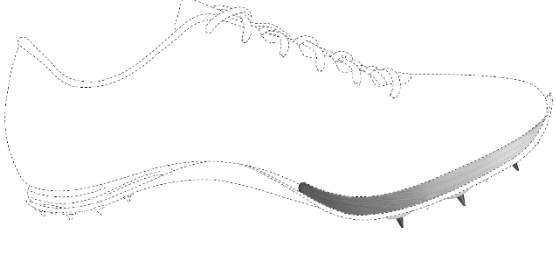



4 39. After the priority date of the D'531 Patent, Brooks introduced the Hyperion Elite
 5 MD.

6 40. The Hyperion Elite MD infringes the D'531 Patent. As shown below, the
 7 Hyperion Elite MD meets every limitation of the D'531 Patent.

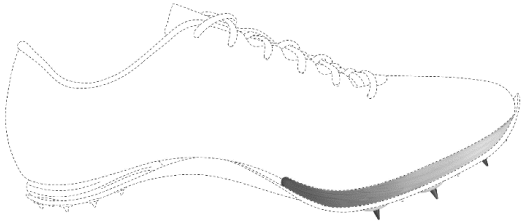
U.S. D1,023,531	Hyperion Elite MD
 <p data-bbox="600 976 641 997">FIG. 1</p>	
 <p data-bbox="600 1291 641 1312">FIG. 2</p>	
 <p data-bbox="600 1596 641 1617">FIG. 3</p>	
 <p data-bbox="600 1869 641 1890">FIG. 4</p>	

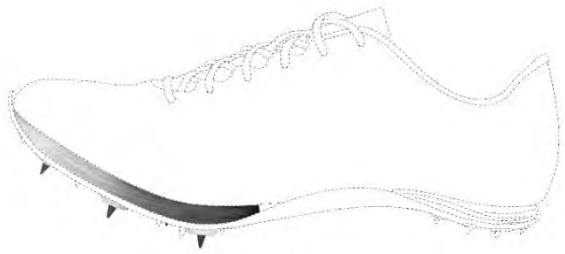
1 41. After the priority date of the D'531 Patent, Brooks introduced the Hyperion Elite
 2 LD.

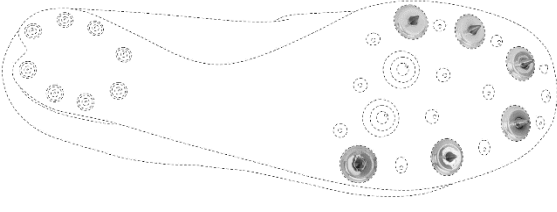
3 42. The Hyperion Elite LD infringes the D'531 Patent. As shown below, the Hyperion
 4 Elite LD meets every limitation of the D'531 Patent.

U.S. D1,023,531	Hyperion Elite LD
 <p data-bbox="584 787 625 808">FIG. 1</p>	
 <p data-bbox="584 1081 625 1102">FIG. 2</p>	
 <p data-bbox="584 1396 625 1417">FIG. 3</p>	
 <p data-bbox="584 1680 625 1701">FIG. 4</p>	

1 43. Plaintiff PUMA SE is the owner by assignment of the entire right, title, and
 2 interest in the D'356 Patent. A true and correct copy of the D'356 Patent is attached hereto as
 3 Exhibit H.

4 44. After the priority date of the D'356 Patent, Brooks introduced the Hyperion Elite
 5 4.

6 45. The Hyperion Elite 4 infringes the D'356 Patent. As shown below, the Hyperion
 7 Elite 4 meets every limitation of the D'356 Patent.

U.S. D1,021,356	Hyperion Elite 4
 <p data-bbox="548 1031 594 1050">FIG. 1</p>	
 <p data-bbox="529 1352 574 1371">FIG. 2</p>	
 <p data-bbox="553 1715 599 1734">FIG. 3</p>	

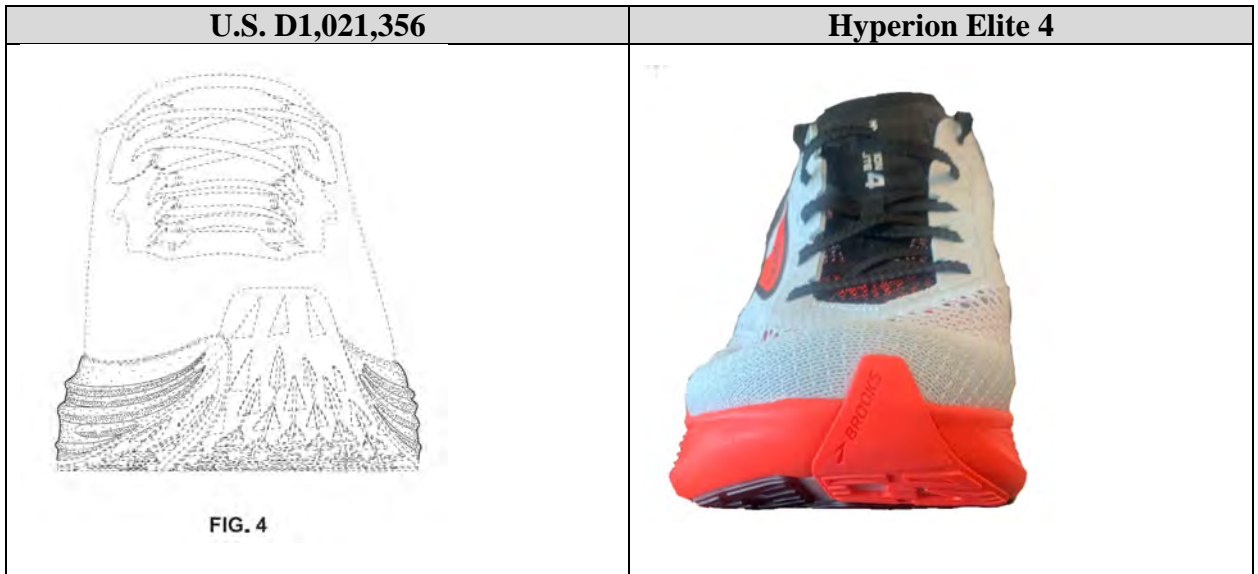

10 46. Plaintiff PUMA SE is the owner by assignment of the entire right, title, and
 11 interest in the D'432 Patent. A true and correct copy of the D'432 Patent is attached hereto as
 12 Exhibit I.

13 47. After the priority date of the D'432 Patent, Brooks introduced the Hyperion Elite
 14 4.

15 48. The Hyperion Elite 4 infringes the D'432 Patent. As shown below, the Hyperion
 16 Elite 4 meets every limitation of the D'432 Patent.

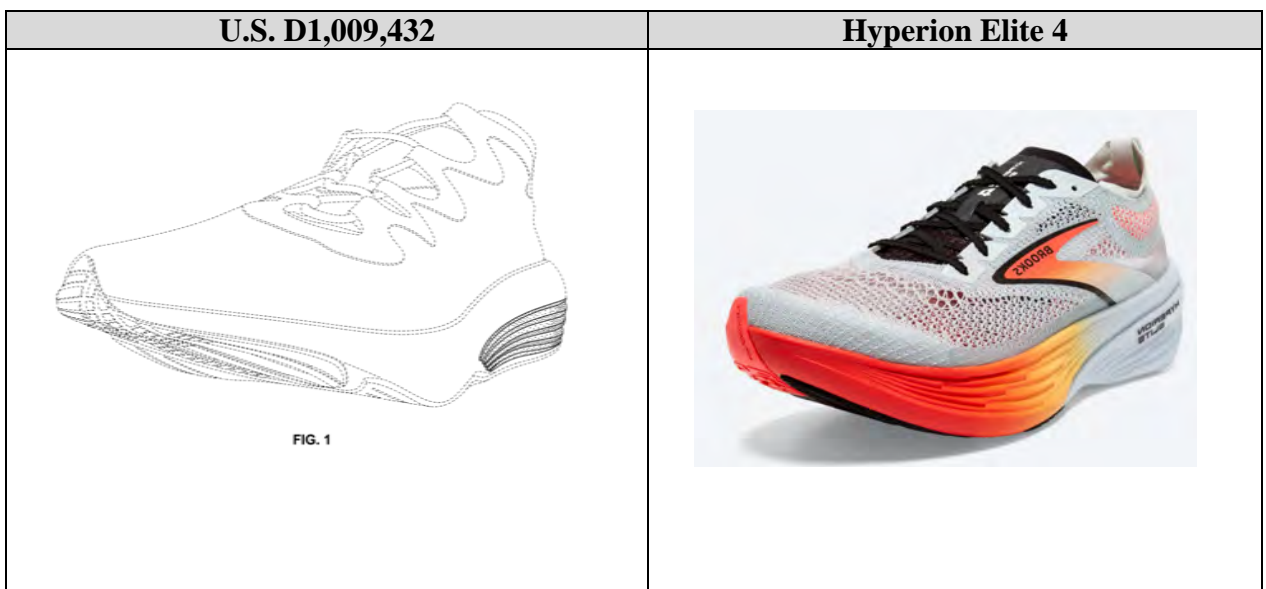

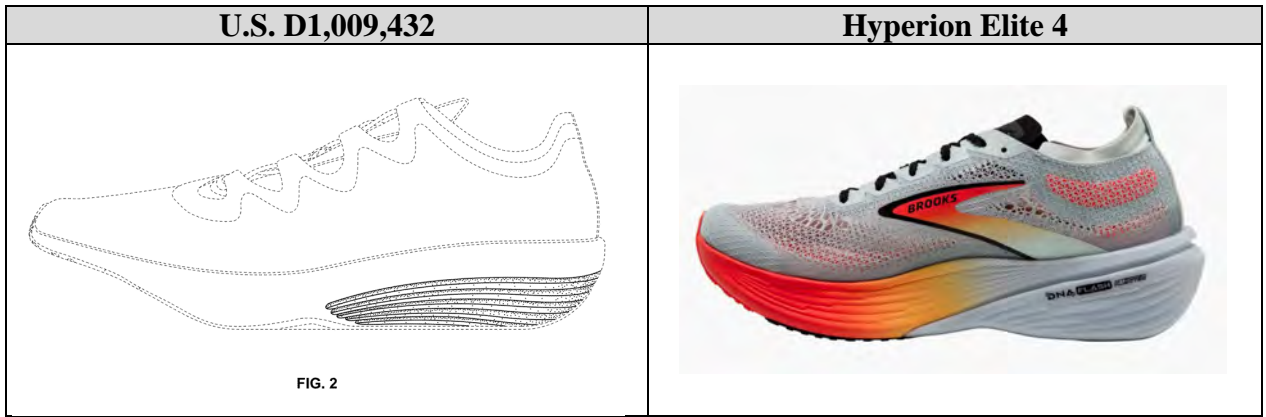

49. Brooks’ routine practice of infringing PUMA’s intellectual property is willful, deliberate, and intentional. Brooks’ complete disregard for PUMA’s intellectual property will continue to irreparably harm PUMA unless enjoined by this Court.

CAUSES OF ACTION

COUNT I:

Infringement of U.S. Patent No. 11,825,904

50. PUMA incorporates by reference the allegations contained in the preceding paragraphs as if separately repeated here.

51. Under 35 U.S.C. § 271(a), Brooks has directly infringed and continues to directly infringe, literally or under the doctrine of equivalents, PUMA’s ’904 Patent by making, using, selling, and offering for sale in the United States, or importing into the United States, a shoe that meets every limitation of at least Claim 14 of the ’904 Patent.

52. At least as January 2024, Brooks has knowledge of the ’904 Patent and of Brooks’ infringement thereof.

53. At least as of January 2024, Brooks’ infringement of the ’904 Patent has been willful.

54. At least as of January 2024, Brooks has actively induced others to directly infringe the ’904 Patent.

55. PUMA has sustained damages as a direct and proximate result of Defendant’s infringement of the ’904 Patent and is entitled to damages pursuant to 35 U.S.C. § 284.

56. Brooks’ infringement has caused, and unless enjoined by this Court under 35

1 U.S.C. § 283, will continue to cause PUMA to suffer irreparable harm for which it cannot be
2 adequately compensated by a monetary award.

3 **COUNT II:**

4 **Infringement of U.S. Patent No. 11,974,629**

5 57. PUMA incorporates by reference the allegations contained in the preceding
6 paragraphs as if separately repeated here.

7 58. Under 35 U.S.C. § 271(a), Brooks has directly infringed and continues to directly
8 infringe, literally or under the doctrine of equivalents, PUMA's '629 Patent by making, using,
9 selling, and offering for sale in the United States, or importing into the United States, a shoe that
10 meets every limitation of at least Claim 1 of the '629 Patent.

11 59. At least as of the filing of this Complaint, Brooks has knowledge of the '629
12 Patent and of Brooks' infringement thereof.

13 60. At least as of the filing of this Complaint, Brooks' infringement of the '629 Patent
14 has been willful.

15 61. At least as of the filing of this Complaint, Brooks has actively induced others to
16 directly infringe the '629 Patent.

17 62. PUMA has sustained damages as a direct and proximate result of Defendant's
18 infringement of the '629 Patent and is entitled to damages pursuant to 35 U.S.C. § 284.

19 63. Brooks' infringement has caused, and unless enjoined by this Court under 35
20 U.S.C. § 283, will continue to cause PUMA to suffer irreparable harm for which it cannot be
21 adequately compensated by a monetary award.

22 **COUNT III:**

23 **Infringement of U.S. Patent No. 11,974,630**

24 64. PUMA incorporates by reference the allegations contained in the preceding
25 paragraphs as if separately repeated here.

26 65. Under 35 U.S.C. § 271(a), Brooks has directly infringed and continues to directly
27 infringe, literally or under the doctrine of equivalents, PUMA's '630 Patent by making, using,
28 selling, and offering for sale in the United States, or importing into the United States, a shoe that

1 meets every limitation of at least Claim 15 of the '630 Patent.

2 66. At least as of the filing of this Complaint, Brooks has knowledge of the '630
3 Patent and of Brooks' infringement thereof.

4 67. At least as of the filing of this Complaint, Brooks' infringement of the '630 Patent
5 has been willful.

6 68. At least as of the filing of this Complaint, Brooks has actively induced others to
7 directly infringe the '630 Patent.

8 69. PUMA has sustained damages as a direct and proximate result of Defendant's
9 infringement of the '630 Patent and is entitled to damages pursuant to 35 U.S.C. § 284.

10 70. Brooks' infringement has caused, and unless enjoined by this Court under 35
11 U.S.C. § 283, will continue to cause PUMA to suffer irreparable harm for which it cannot be
12 adequately compensated by a monetary award.

13 **COUNT IV:**

14 **Infringement of U.S. Patent No. 12,016,422**

15 71. PUMA incorporates by reference the allegations contained in the preceding
16 paragraphs as if separately repeated here.

17 72. Under 35 U.S.C. § 271(a), Brooks has directly infringed and continues to directly
18 infringe, literally or under the doctrine of equivalents, PUMA's '422 Patent by making, using,
19 selling, and offering for sale in the United States, or importing into the United States, one or more
20 shoes that meet every limitation of at least Claim 9 of the '422 Patent.

21 73. At least as of the filing of this Complaint, Brooks has knowledge of the '422
22 Patent and of Brooks' infringement thereof.

23 74. At least as of the filing of this Complaint, Brooks' infringement of the '422 Patent
24 has been willful.

25 75. At least as of the filing of this Complaint, Brooks has actively induced others to
26 directly infringe the '422 Patent.

27
28 76. PUMA has sustained damages as a direct and proximate result of Defendant's

1 infringement of the '422 Patent and is entitled to damages pursuant to 35 U.S.C. § 284.

2 77. Brooks' infringement has caused, and unless enjoined by this Court under 35
3 U.S.C. § 283, will continue to cause PUMA to suffer irreparable harm for which it cannot be
4 adequately compensated by a monetary award.

5 **COUNT V:**

6 **Design Patent Infringement of U.S. Patent No. D1,002,421**

7 78. PUMA incorporates by reference the allegations contained in the preceding
8 paragraphs as if separately repeated here.

9 79. Under 35 U.S.C. § 271(a), Brooks has infringed and continues to infringe, literally
10 or under the doctrine of equivalents, PUMA's D'421 Patent by making, using, selling, and
11 offering for sale in the United States, or importing into the United States, a shoe that embodies the
12 design covered by the D'421 Patent.

13 80. Brooks has profited from the sales of its Brooks Hyperion Elite MD.

14 81. Brooks has profited from the sales of its Brooks Hyperion Elite LD.

15 82. Brooks has profited from its infringement of the D'421 Patent.

16 83. PUMA has sustained damages as a direct and proximate result of Brooks'
17 infringement of the D'421 Patent and is entitled to damages pursuant to 35 U.S.C. §§ 284 and
18 289.

19 84. Brooks' infringement has caused, and unless enjoined by this Court under 35
20 U.S.C. § 283, will continue to cause PUMA to suffer irreparable harm for which it cannot be
21 adequately compensated by a monetary award.

22 **COUNT VI:**

23 **Design Patent Infringement of U.S. Patent No. D1,002,422**

24 85. PUMA incorporates by reference the allegations contained in the preceding
25 paragraphs as if separately repeated here.

26 86. Under 35 U.S.C. § 271(a), Brooks has infringed and continues to infringe, literally
27 or under the doctrine of equivalents, PUMA's D'422 Patent by making, using, selling, and
28 offering for sale in the United States, or importing into the United States, a shoe that embodies the

COMPLAINT

1 design covered by the D'422 Patent.

2 87. Brooks has profited from the sales of its Brooks Hyperion Elite MD.

3 88. Brooks as profited from the sales of its Brooks Hyperion Elite LD.

4 89. Brooks has profited from its infringement of the D'422 Patent.

5 90. PUMA has sustained damages as a direct and proximate result of Brooks'
6 infringement of the D'422 Patent and is entitled to damages pursuant to 35 U.S.C. §§ 284 and
7 289.

8 91. Brooks' infringement has caused, and unless enjoined by this Court under 35
9 U.S.C. § 283, will continue to cause PUMA to suffer irreparable harm for which it cannot be
10 adequately compensated by a monetary award.

11 **COUNT VII:**

12 **Design Patent Infringement of U.S. Patent No. D1,023,531**

13 92. PUMA incorporates by reference the allegations contained in the preceding
14 paragraphs as if separately repeated here.

15 93. Under 35 U.S.C. § 271(a), Brooks has infringed and continues to infringe, literally
16 or under the doctrine of equivalents, PUMA's D'531 Patent by making, using, selling, and
17 offering for sale in the United States, or importing into the United States, a shoe that embodies the
18 design covered by the D'531 Patent.

19 94. Brooks has profited from the sales of its Brooks Hyperion Elite MD.

20 95. Brooks has profited from the sales of its Brooks Hyperion Elite LD.

21 96. Brooks has profited from its infringement of the D'531 Patent.

22 97. PUMA has sustained damages as a direct and proximate result of Brooks'
23 infringement of the D'531 Patent and is entitled to damages pursuant to 35 U.S.C. §§ 284 and
24 289.

25 98. Brooks' infringement has caused, and unless enjoined by this Court under 35
26 U.S.C. § 283, will continue to cause PUMA to suffer irreparable harm for which it cannot be
27 adequately compensated by a monetary award.

COUNT VIII:

Design Patent Infringement of U.S. Patent No. D1,021,356

99. PUMA incorporates by reference the allegations contained in the preceding paragraphs as if separately repeated here.

100. Under 35 U.S.C. § 271(a), Brooks has infringed and continues to infringe, literally or under the doctrine of equivalents, PUMA’s D’356 Patent by making, using, selling, and offering for sale in the United States, or importing into the United States, a shoe that embodies the design covered by the D’356 Patent.

101. Brooks has profited from its sales of its Hyperion Elite 4.

102. Brooks has profited from its infringement of the D’356 Patent.

103. PUMA has sustained damages as a direct and proximate result of Brooks’ infringement of the D’356 Patent and is entitled to damages pursuant to 35 U.S.C. §§ 284 and 289.

104. Brooks’ infringement has caused, and unless enjoined by this Court under 35 U.S.C. § 283, will continue to cause PUMA to suffer irreparable harm for which it cannot be adequately compensated by a monetary award.

COUNT IX:

Design Patent Infringement of U.S. Patent No. D1,009,432

105. PUMA incorporates by reference the allegations contained in the preceding paragraphs as if separately repeated here.

106. Under 35 U.S.C. § 271(a), Brooks has infringed and continues to infringe, literally or under the doctrine of equivalents, PUMA’s D’432 Patent by making, using, selling, and offering for sale in the United States, or importing into the United States, a shoe that embodies the design covered by the D’432 Patent.

107. Brooks has profited from its sales of its Hyperion Elite 4.

108. Brooks has profited from its infringement of the D’432 Patent.

1
2
3
4
5
6
7
8
9
10
11
12
13
14
15
16
17
18
19
20
21
22
23
24
25
26
27
28

Dated: June 27, 2024

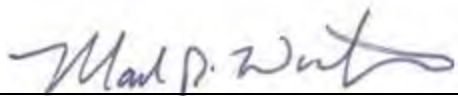
By: 

Mark P. Walters
LOWE GRAHAM JONES PLLC
1325 Fourth Avenue, Suite 1130
Seattle, WA 98101
walters@lowegrahamjones.com
Tel: 206-381-3300

Johanna M. Wilbert (*pro hac vice application forthcoming*)
Michael T. Piery (*pro hac vice application forthcoming*)
QUARLES & BRADY LLP
411 East Wisconsin Ave., Suite 1400
Milwaukee, WI 53202
johanna.wilbert@quarles.com
michael.piery@quarles.com
Tel: 414-277-5000

Matthew C. Holohan (*pro hac vice application forthcoming*)
Kent Dallow (*pro hac vice application forthcoming*)
QUARLES & BRADY LLP
8210 Southpark Terrace
Littleton, CO 80120
matthew.holohan@quarles.com
kent.dallow@quarles.com
Tel: 303-268-0066

Attorneys for Plaintiffs
PUMA SE and PUMA North America Inc.

EXHIBIT A



(12) **United States Patent**
Redon et al.

(10) **Patent No.:** **US 11,825,904 B2**
 (45) **Date of Patent:** **Nov. 28, 2023**

(54) **ARTICLE OF FOOTWEAR HAVING A SOLE PLATE**

- (71) Applicant: **PUMA SE**, Herzogenaurach (DE)
- (72) Inventors: **Arnaud Redon**, Nuremberg (DE);
Romain Girard, Lauf an der Pegnitz (DE)
- (73) Assignee: **PUMA SE**, Herzogenaurach (DE)
- (*) Notice: Subject to any disclaimer, the term of this patent is extended or adjusted under 35 U.S.C. 154(b) by 0 days.

(21) Appl. No.: **18/114,670**

(22) Filed: **Feb. 27, 2023**

(65) **Prior Publication Data**
 US 2023/0200489 A1 Jun. 29, 2023

Related U.S. Application Data

- (63) Continuation of application No. 17/404,388, filed on Aug. 17, 2021, now Pat. No. 11,622,602.
- (60) Provisional application No. 63/067,073, filed on Aug. 18, 2020.
- (51) **Int. Cl.**
A43B 13/18 (2006.01)
A43B 13/04 (2006.01)
- (52) **U.S. Cl.**
 CPC *A43B 13/186* (2013.01); *A43B 13/04* (2013.01)
- (58) **Field of Classification Search**
 None
 See application file for complete search history.

(56) **References Cited**

U.S. PATENT DOCUMENTS

4,020,569 A	5/1977	Fukuoka	
4,542,598 A *	9/1985	Misevich	A43B 13/16 36/31
5,052,130 A	10/1991	Barry et al.	
5,191,727 A	3/1993	Barry et al.	
5,315,769 A	5/1994	Barry et al.	
5,528,842 A	6/1996	Ricci et al.	
6,389,713 B1	5/2002	Kita	
D466,272 S	12/2002	Erickson	
D472,038 S	3/2003	Meynard	

(Continued)

FOREIGN PATENT DOCUMENTS

CN	111213958 A	6/2020
CN	212014663 U	11/2020

(Continued)

OTHER PUBLICATIONS

International Search Report and the Written Opinion of the International Searching Authority from corresponding PCT Application No. PCT/IB2021/057602 dated Nov. 12, 2021 (14 pages).

(Continued)

Primary Examiner — Jila M Mohandesi

(74) *Attorney, Agent, or Firm* — Quarles & Brady LLP

(57) **ABSTRACT**

A sole structure for an article of footwear having an upper includes a first cushioning member disposed in a heel region of the sole structure and a second cushioning member disposed in a forefoot region of the sole structure. The second cushioning member is spaced apart from the first cushioning member by a gap that extends between the first cushioning member and the second cushioning member. A sole plate extends across the gap between the first cushioning member and the second cushioning member.

33 Claims, 41 Drawing Sheets

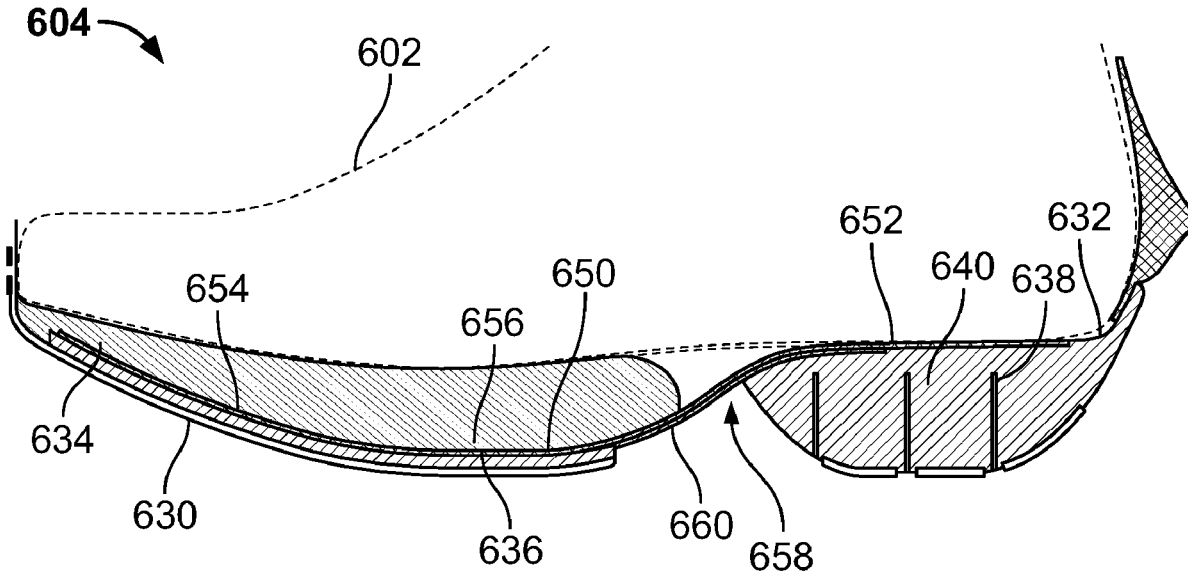

US 11,825,904 B2

Page 2

(56)

References Cited

U.S. PATENT DOCUMENTS

6,625,905 B2 *	9/2003	Kita	A43B 13/12	D937,549 S	12/2021	Della Valle
				36/28	D938,155 S	12/2021	Nikolic
D481,200 S	10/2003	Belley			D943,883 S	2/2022	Bertelli
6,634,121 B2 *	10/2003	Sordi	A43B 13/141	D945,130 S	3/2022	Park
				36/31	D945,138 S	3/2022	Mitchell
6,662,469 B2	12/2003	Belley et al.			D957,097 S	7/2022	Park
D489,880 S	5/2004	McClaskie			D969,469 S	11/2022	Redon
6,920,705 B2	7/2005	Lucas et al.			11,622,602 B2 *	4/2023	Redon
7,401,422 B1	7/2008	Scholz et al.					A43B 13/125
7,484,317 B2	2/2009	Kita et al.			2002/0078591 A1 *	6/2002	Morrone
7,513,065 B2	4/2009	Kita et al.					A43B 5/12
7,624,515 B2	12/2009	Kita et al.					36/102
7,987,618 B2	8/2011	Nishiwaki et al.			2003/0079374 A1	5/2003	Belley
8,074,377 B2	12/2011	Nishiwaki et al.			2006/0137228 A1	6/2006	Kubo et al.
8,112,909 B2	2/2012	Kubo et al.			2007/0101617 A1	5/2007	Brewer et al.
8,387,279 B2	3/2013	Pauk et al.			2008/0052965 A1	3/2008	Sato
8,393,028 B2	3/2013	Namkook et al.			2010/0218397 A1	9/2010	Nishiwaki et al.
8,418,379 B2	4/2013	Nishiwaki et al.			2011/0203137 A1	8/2011	Long
D707,432 S	6/2014	Mochen			2016/0029741 A1	2/2016	Foxen
8,850,718 B2 *	10/2014	Lubart	A43B 13/026	2016/0073734 A1	3/2016	Grabher et al.
				36/31	2017/0035143 A1	2/2017	Sato et al.
8,850,721 B2 *	10/2014	Long	A43B 7/22	2017/0079376 A1	3/2017	Bunnell et al.
				36/107	2018/0132564 A1 *	5/2018	Bruce
9,572,398 B2	2/2017	Hurd et al.			2018/0271215 A1	9/2018	Foxen
D783,960 S	4/2017	Hatfield			2020/0008519 A1	1/2020	Farris et al.
D817,612 S	5/2018	Small			2020/0100564 A1	4/2020	Bunnell et al.
10,010,137 B2 *	7/2018	Foxen	A43B 13/42	2020/0100565 A1	4/2020	Yoshida et al.
10,226,097 B2	3/2019	Farris et al.			2020/0114634 A1 *	4/2020	Hensley
10,226,099 B2 *	3/2019	Bischoff	B29D 35/122	2022/0053879 A1	2/2022	Redon
10,299,535 B2	5/2019	Hurd et al.			2022/0225729 A1	7/2022	Bonin
D854,293 S	7/2019	Mokos					
D861,308 S	10/2019	Chang					
D863,744 S	10/2019	Della Valle					
D864,530 S	10/2019	Verfl					
10,448,701 B2	10/2019	Farris et al.					
D866,146 S	11/2019	Cass					
D872,983 S	1/2020	Louboutin					
10,524,536 B2	1/2020	Bunnell et al.					
D889,798 S	2/2020	Vella					
D890,496 S	2/2020	Le					
D877,465 S	3/2020	Hartmann					
D878,026 S	3/2020	Nikolic					
D879,437 S	3/2020	Brosseau					
D879,438 S	3/2020	Brosseau					
D885,729 S	6/2020	Swierszczyk					
D893,140 S	8/2020	Felloni					
D893,144 S	8/2020	Sfredda					
D895,244 S	9/2020	Felloni					
D897,082 S	9/2020	Belforti					
10,765,172 B2	9/2020	Foxen					
D898,331 S	10/2020	Taylor					
D899,038 S	10/2020	Thompson					
D900,458 S	11/2020	Swierszczyk					
D905,391 S	12/2020	Papp					
D905,938 S	12/2020	Sfredda					
D907,342 S	1/2021	Odinot					
D917,137 S	4/2021	Carson					
D918,548 S	5/2021	Bracalente					
D919,261 S	5/2021	Brosseau					
D919,262 S	5/2021	Brosseau					
D923,925 S	7/2021	Bramani					
11,089,834 B2 *	8/2021	Chambers	A43B 21/26			

FOREIGN PATENT DOCUMENTS

DE	4137350	A1	5/1993
DE	202013003797	U1	7/2013
EP	1346655	B1	8/2006
EP	1894484	B1	3/2018
EP	2911542	B1	12/2018
EP	3434132	A1	1/2019
EP	3174419	B1	7/2019
EP	3574791	A1	12/2019
EP	3316719	B1	5/2020
EP	3316721	B1	5/2020
KR	101057729	B1	8/2011
KR	20190075138	A	6/2019
WO	1995003719	A1	2/1995
WO	2011050720	A1	5/2011
WO	2012115343	A1	8/2012
WO	2017048934	A1	3/2017
WO	2017048937	A1	3/2017
WO	2017048938	A1	3/2017
WO	2017048939	A1	3/2017

OTHER PUBLICATIONS

Good Luck Trainer, ToryBurch.com, [online], [site visited Apr. 11, 2022]. URL: <https://www.toryburch.com/en-eu/shoes/sneakers/good-luck-trainer/85463.html>. (Year: 2022).

Beau Today Womens Chink Sneakers Platform Das Shoes for Women, Ubuy.com, [online], site visited Apr. 11, 2022]. URL: <https://www.ubuy.com.tr/en/product/1IZIAHXK8-beau-today-women-s-chunky-sneakers-platform-dad-shoes-for-women-beige-brown-us-6-5> (Year: 2022).

* cited by examiner

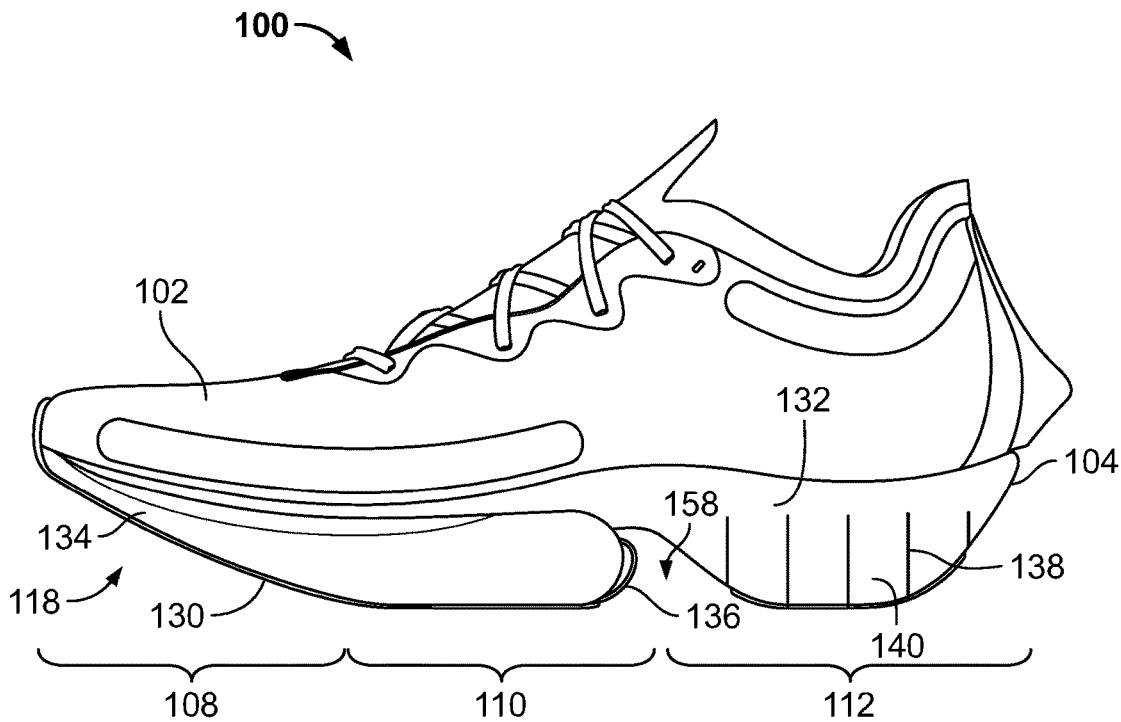

FIG. 1

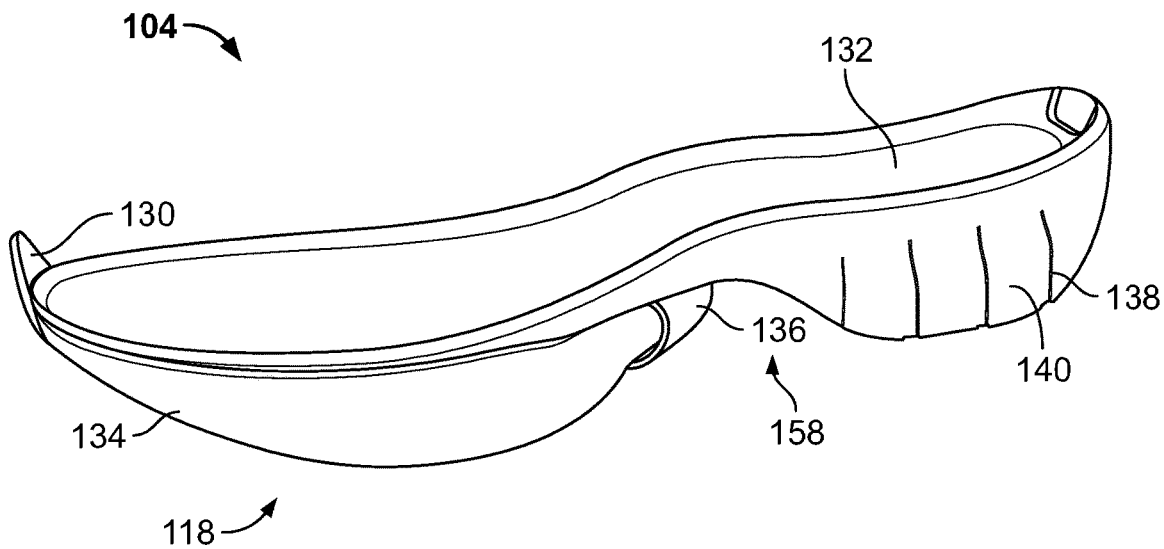

FIG. 2

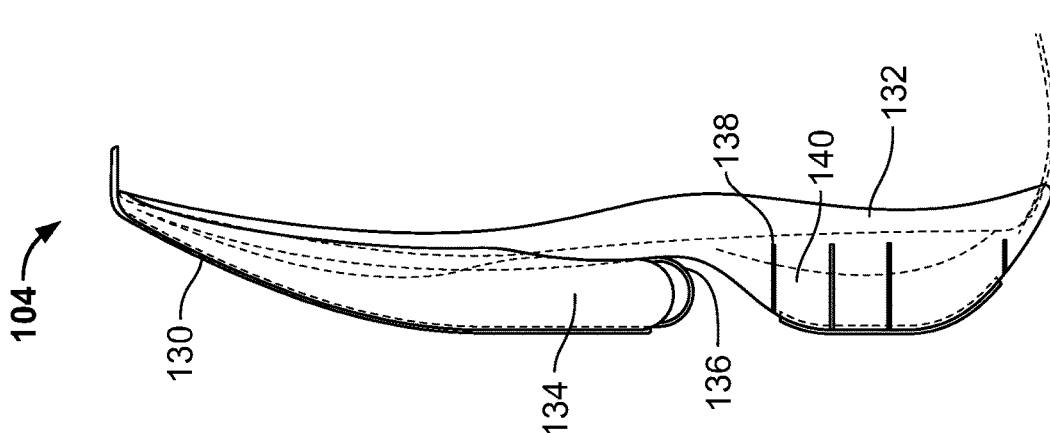

FIG. 3

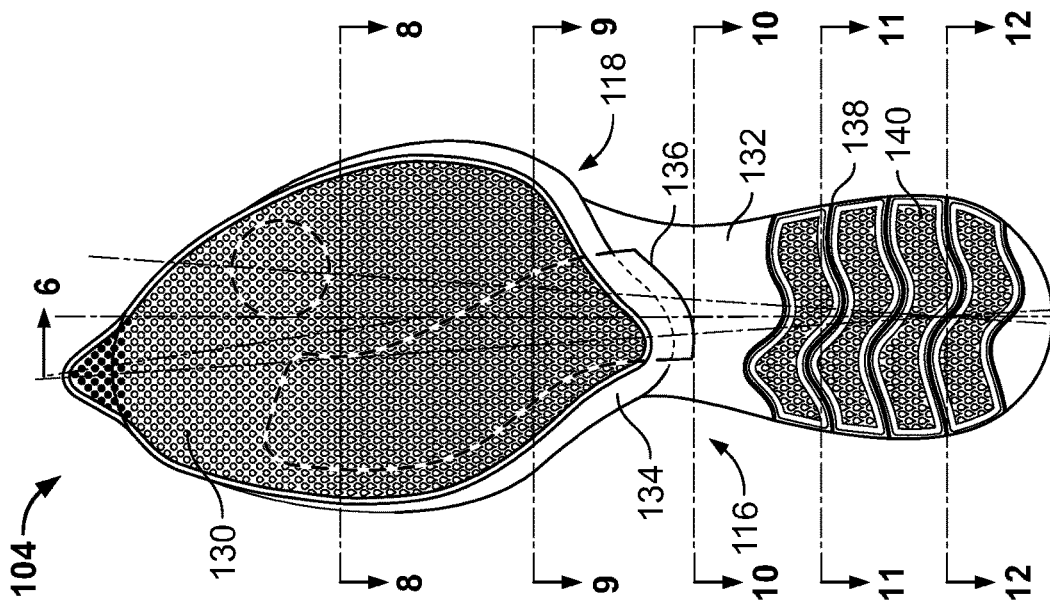

FIG. 4

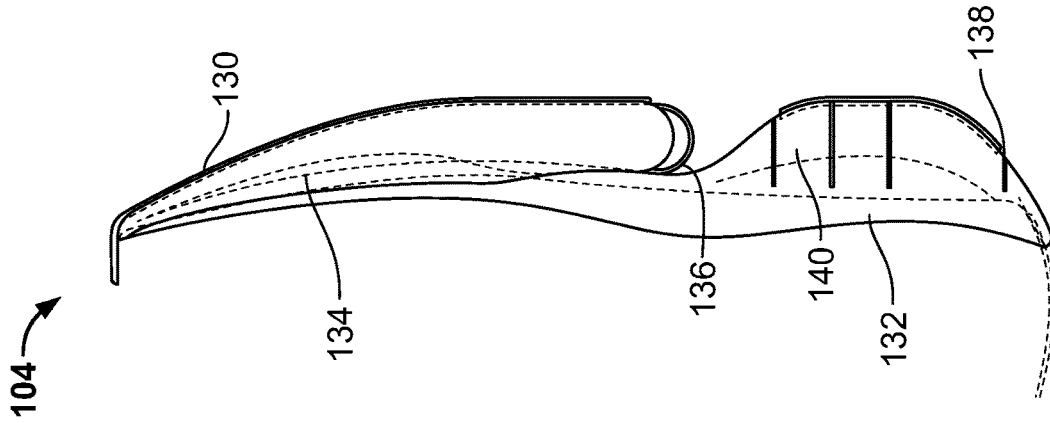
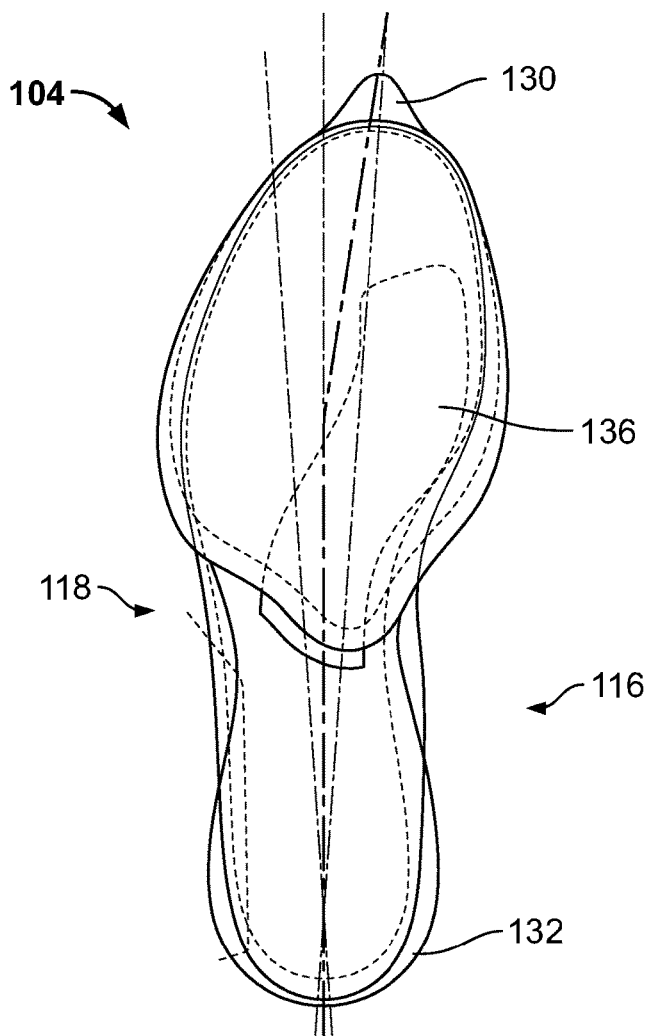
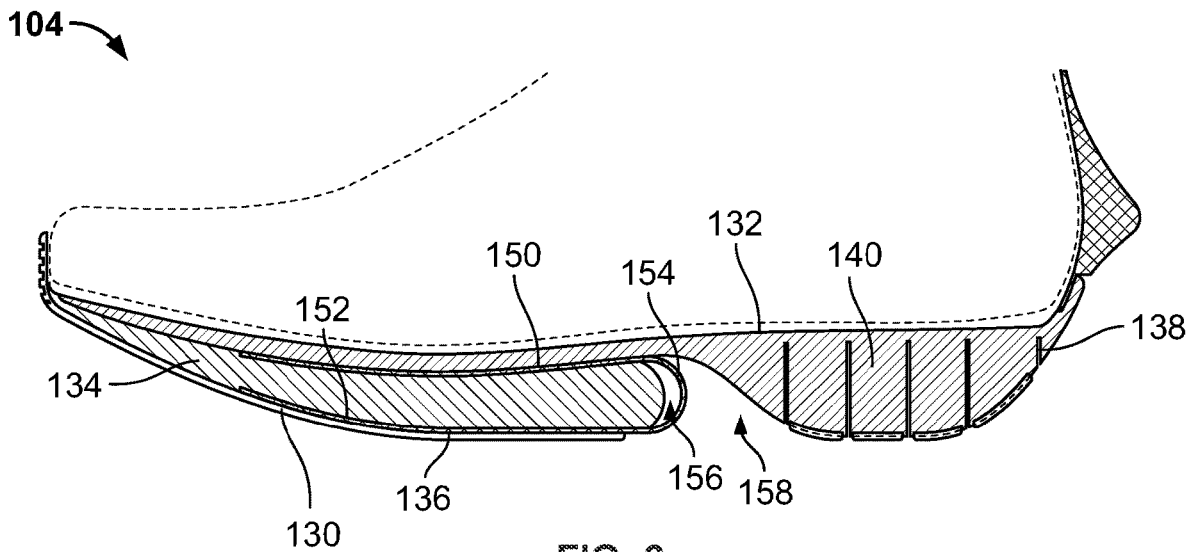

FIG. 5



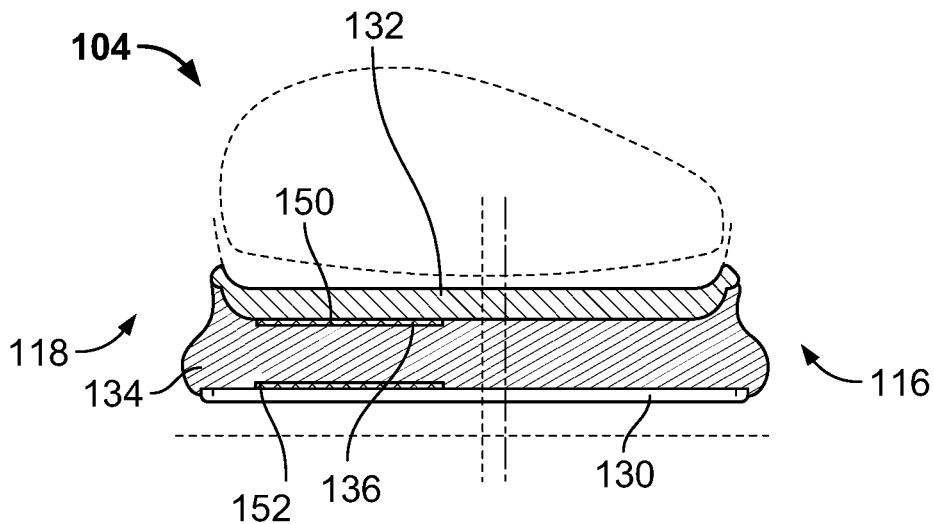

FIG. 8

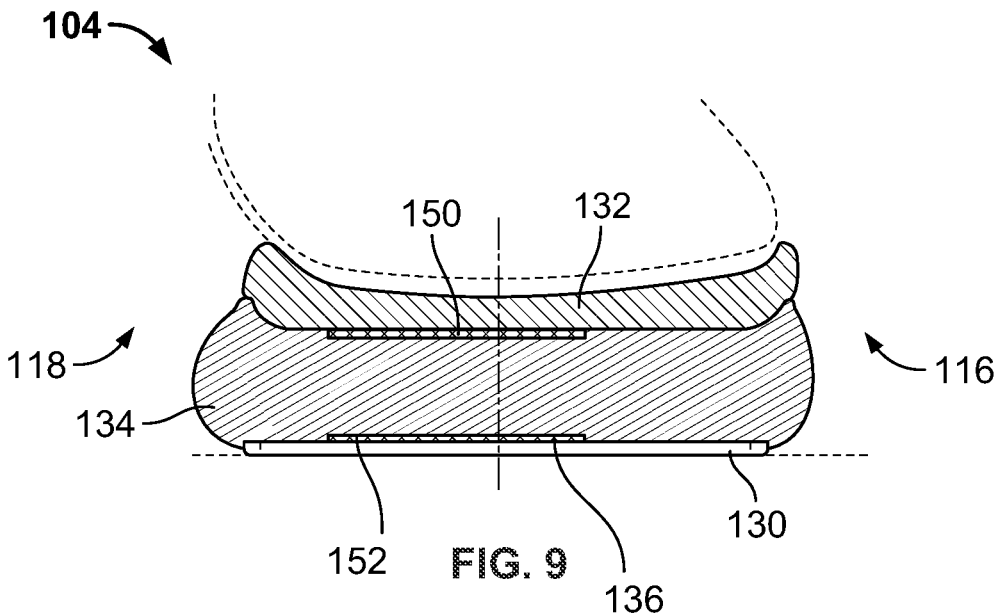

FIG. 9

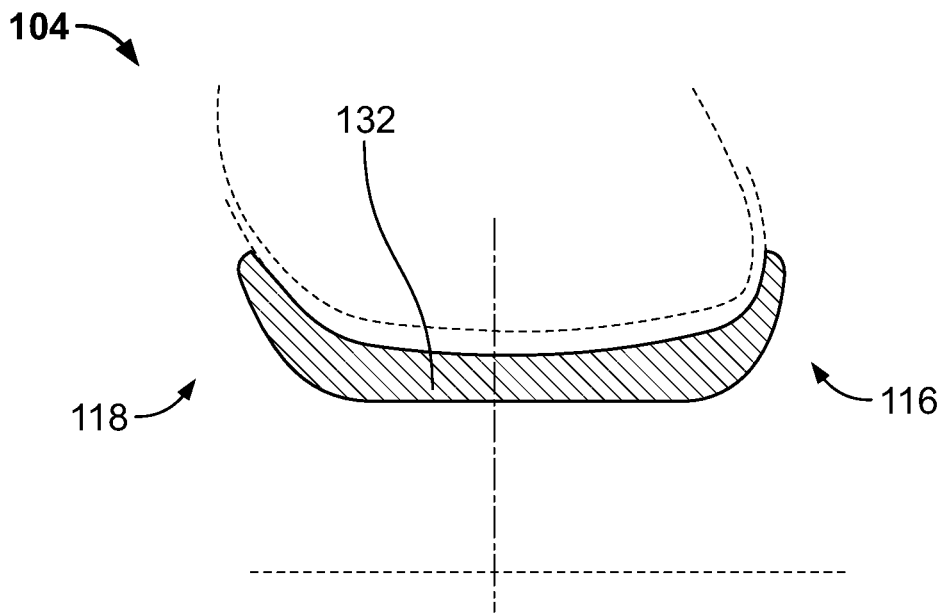

FIG. 10

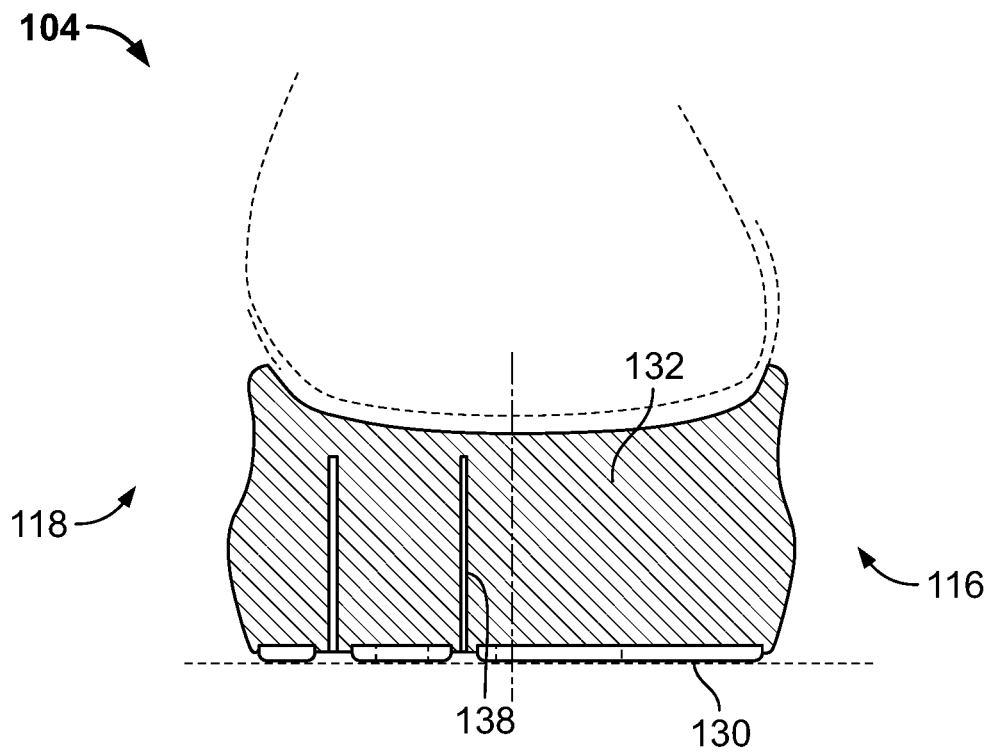

FIG. 11

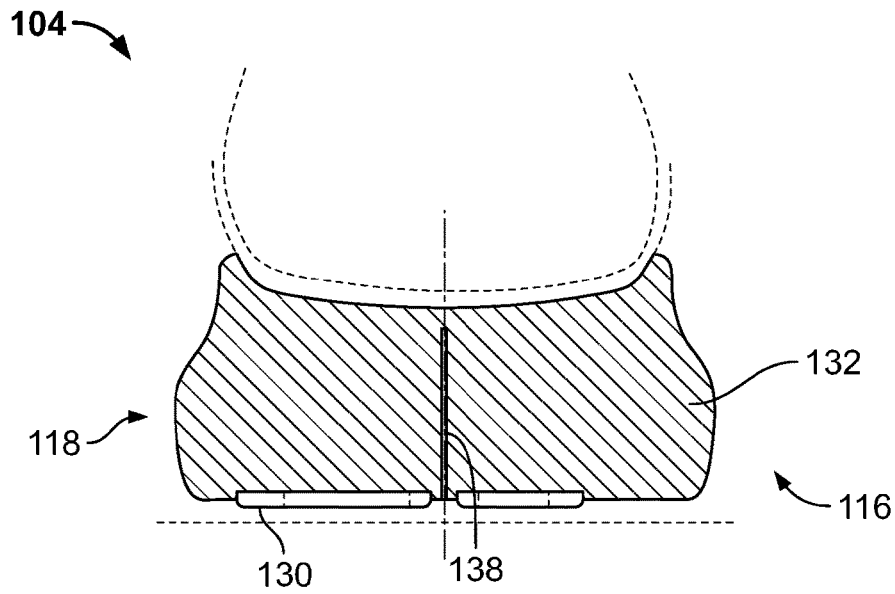

FIG. 12

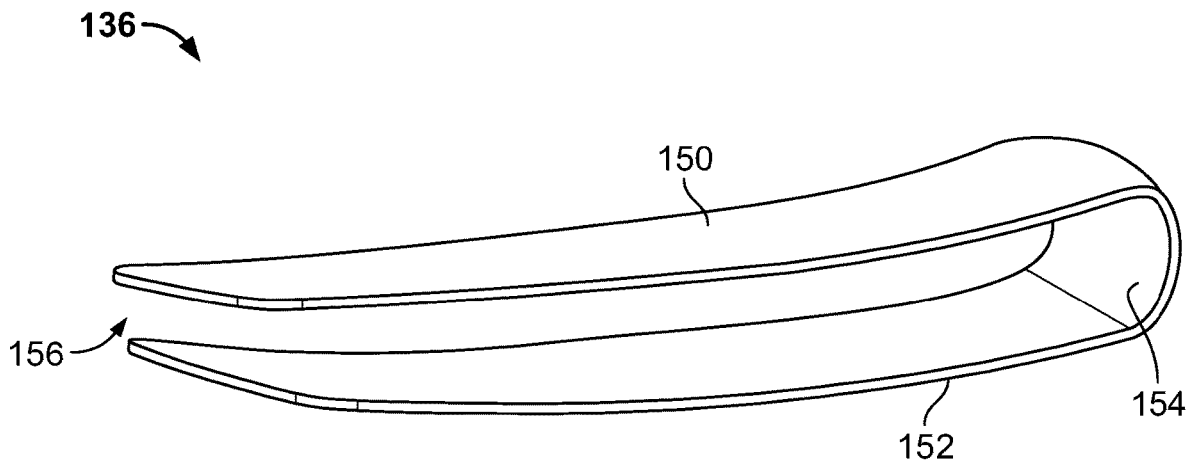

FIG. 13

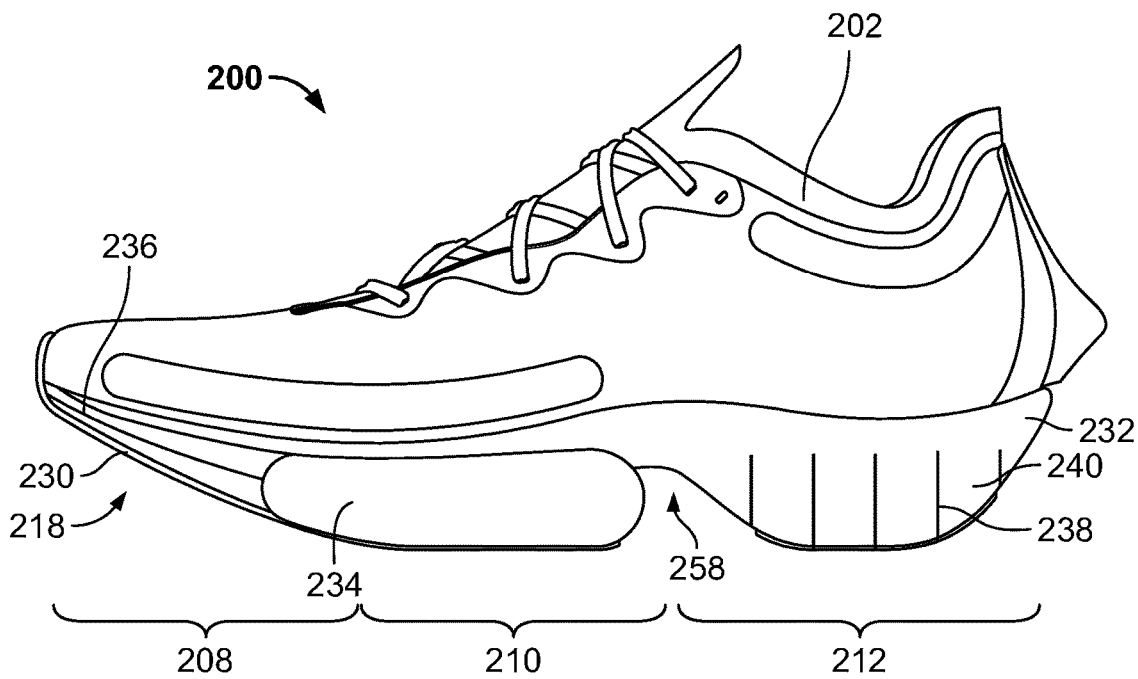

FIG. 14

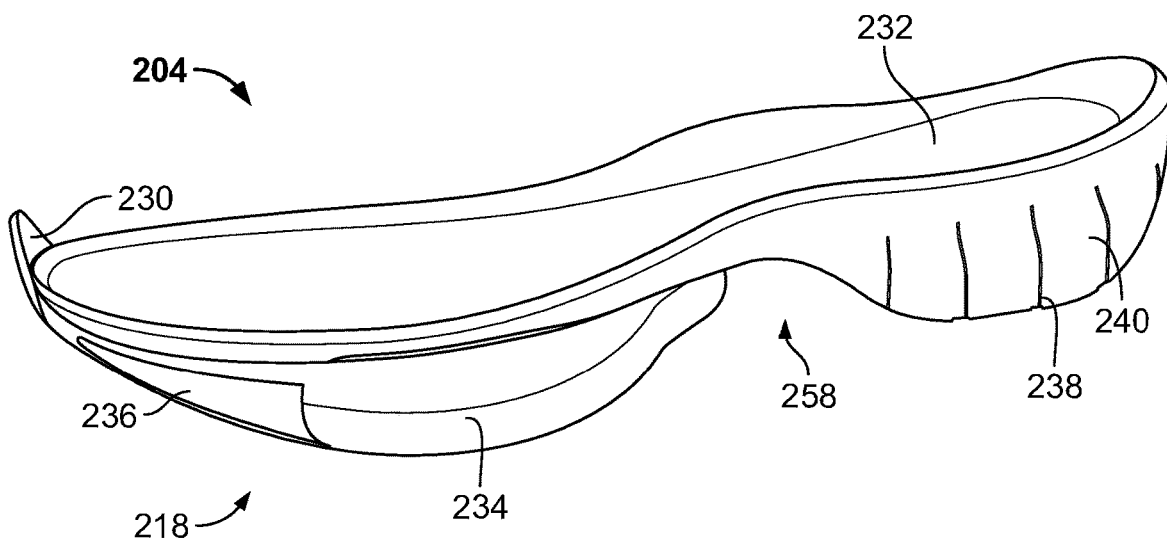

FIG. 15

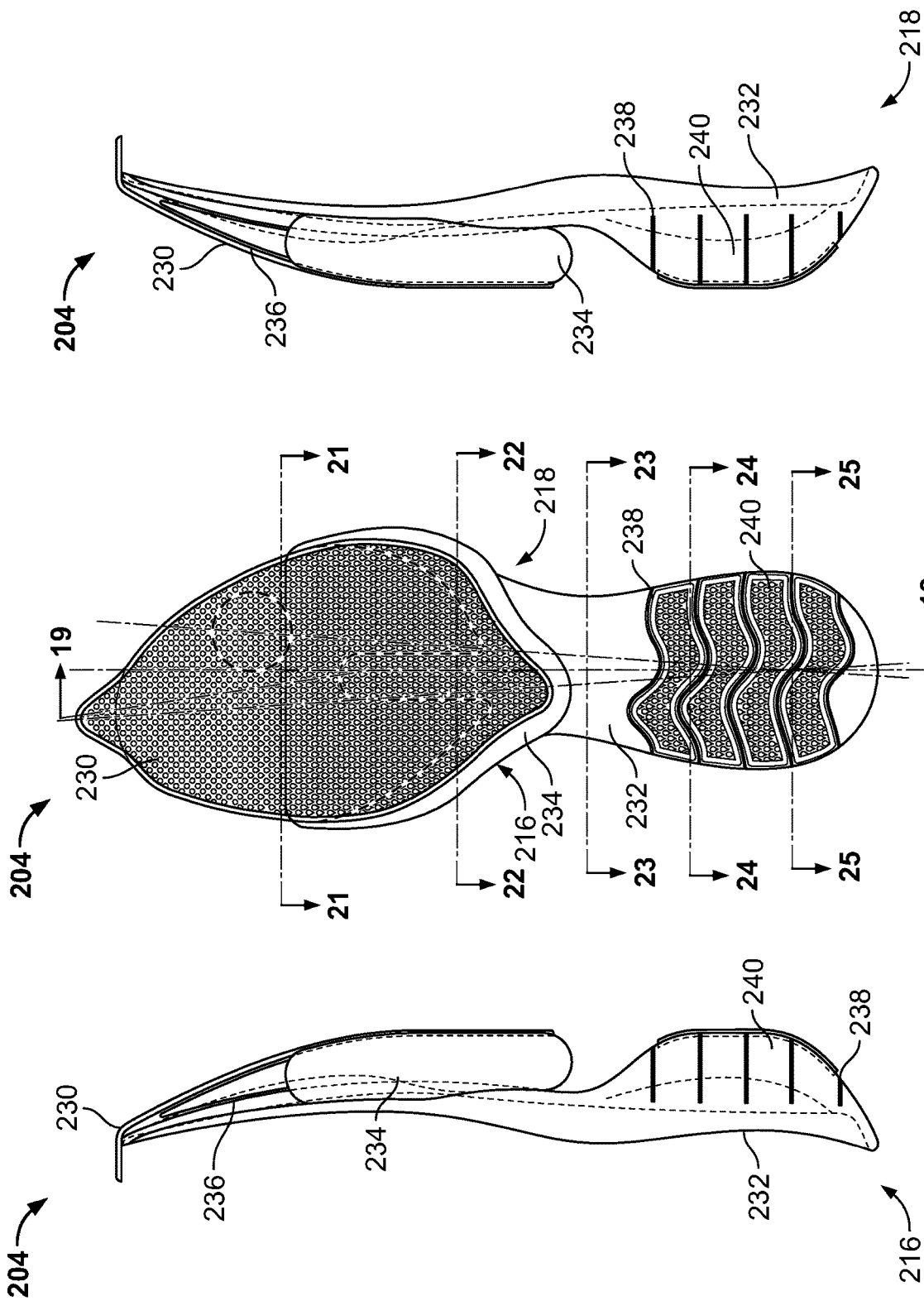

FIG. 16

FIG. 17

FIG. 18

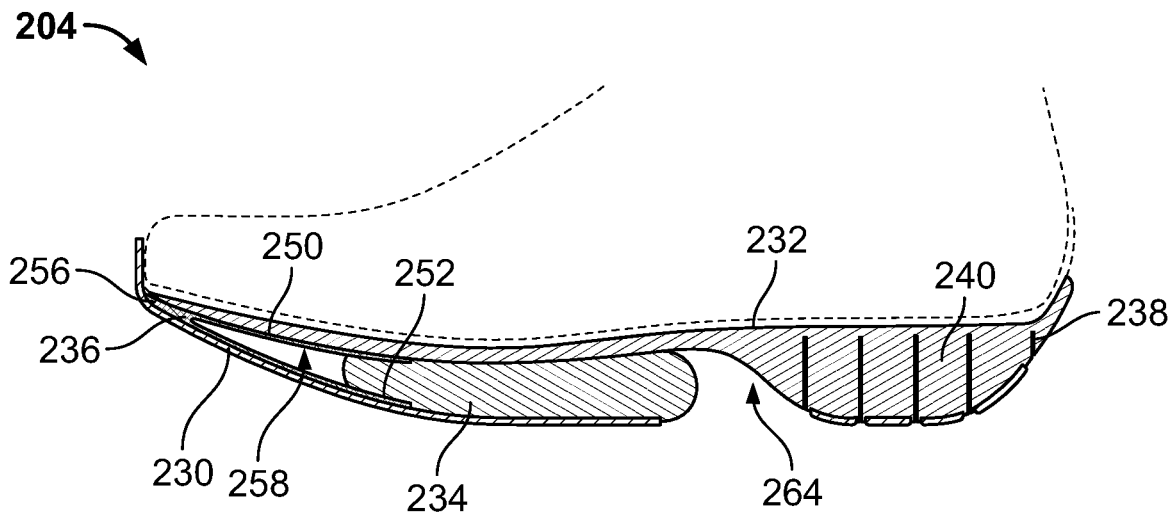

FIG. 19

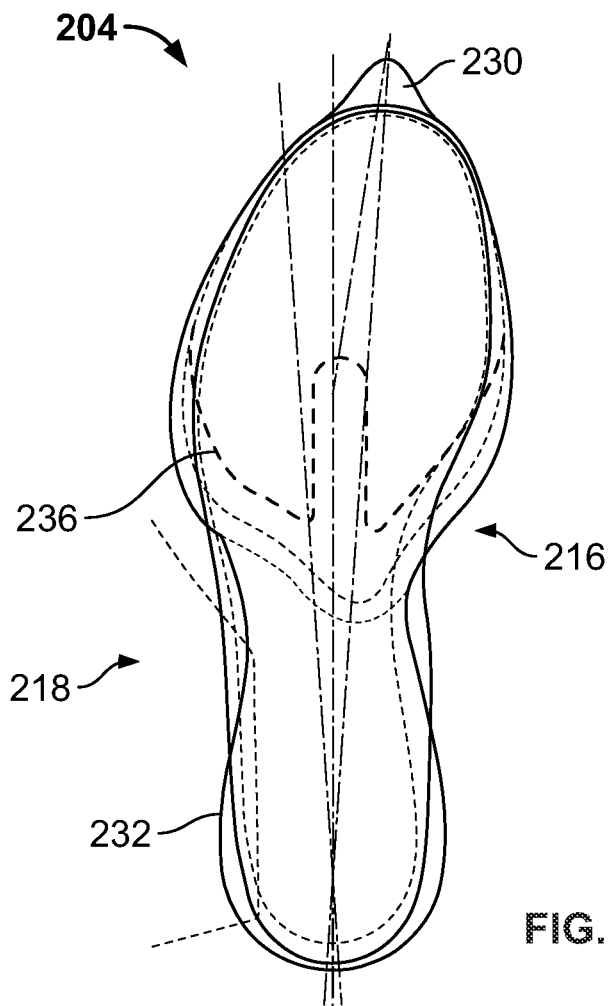

FIG. 20

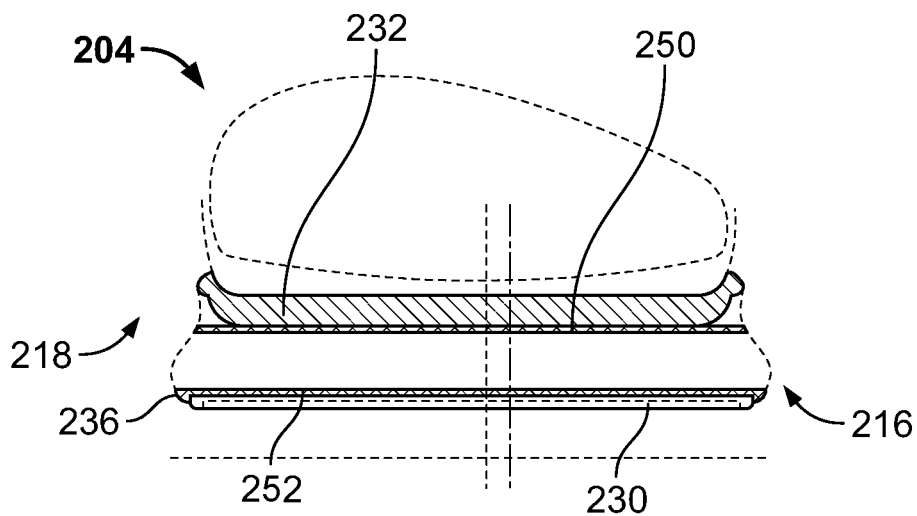

FIG. 21

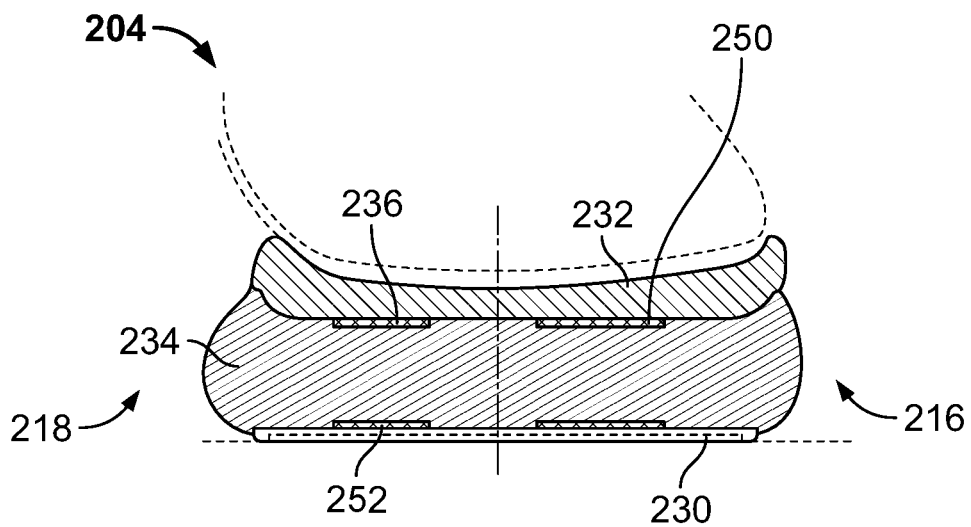

FIG. 22

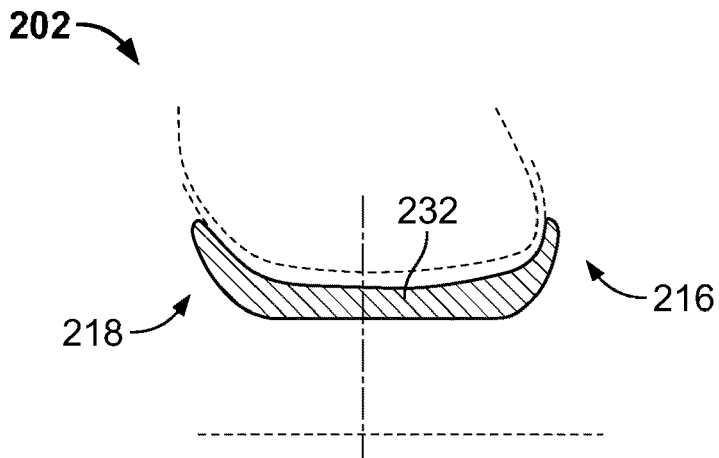

FIG. 23

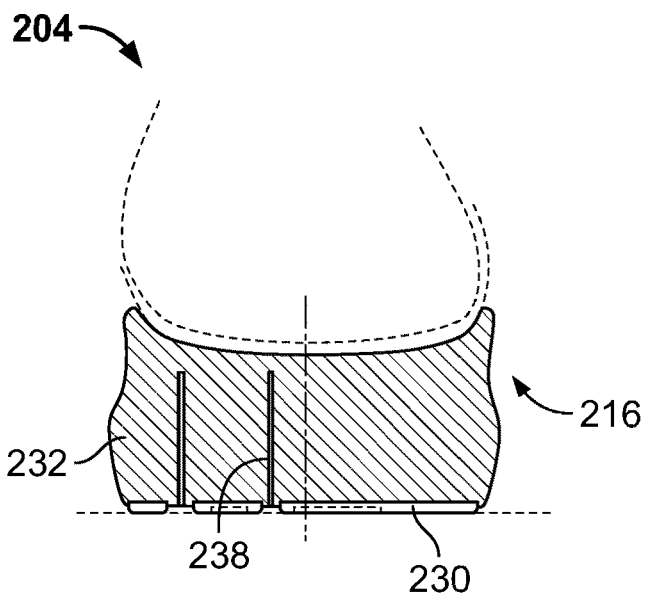

FIG. 24

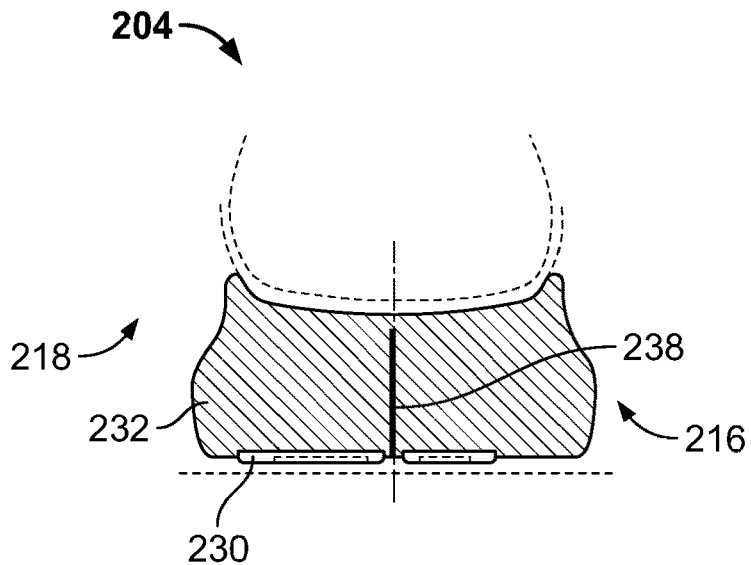

FIG. 25

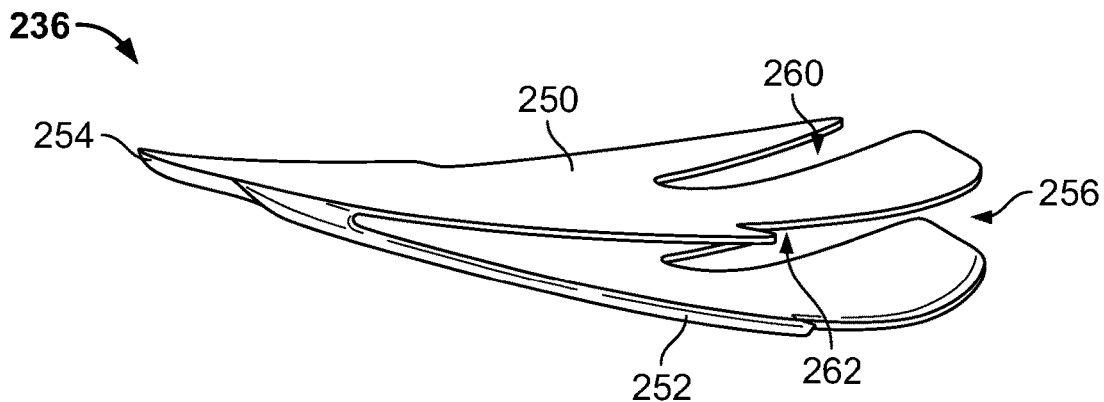

FIG. 26

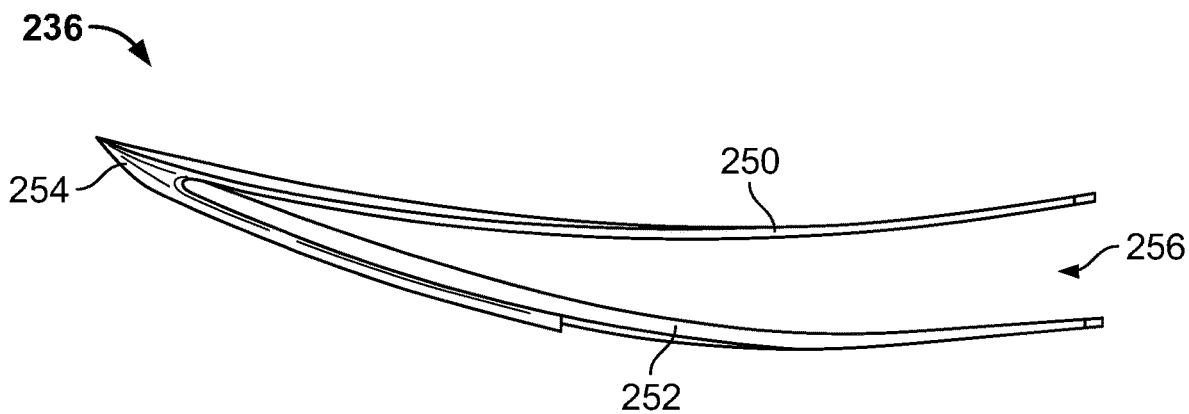

FIG. 27

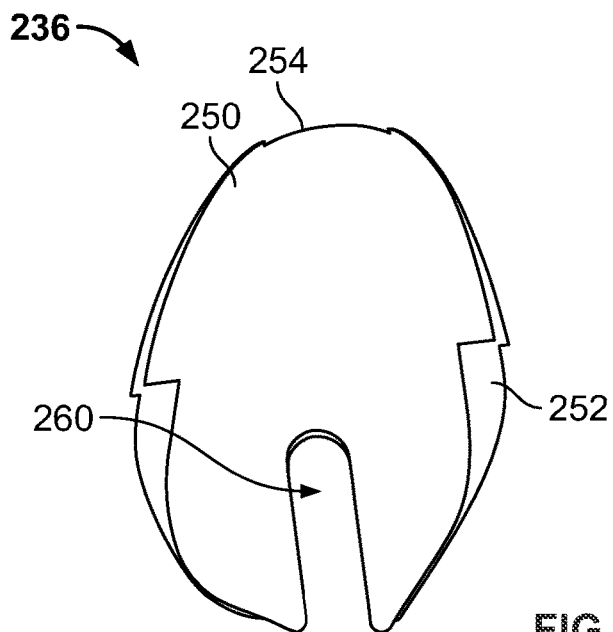

FIG. 28

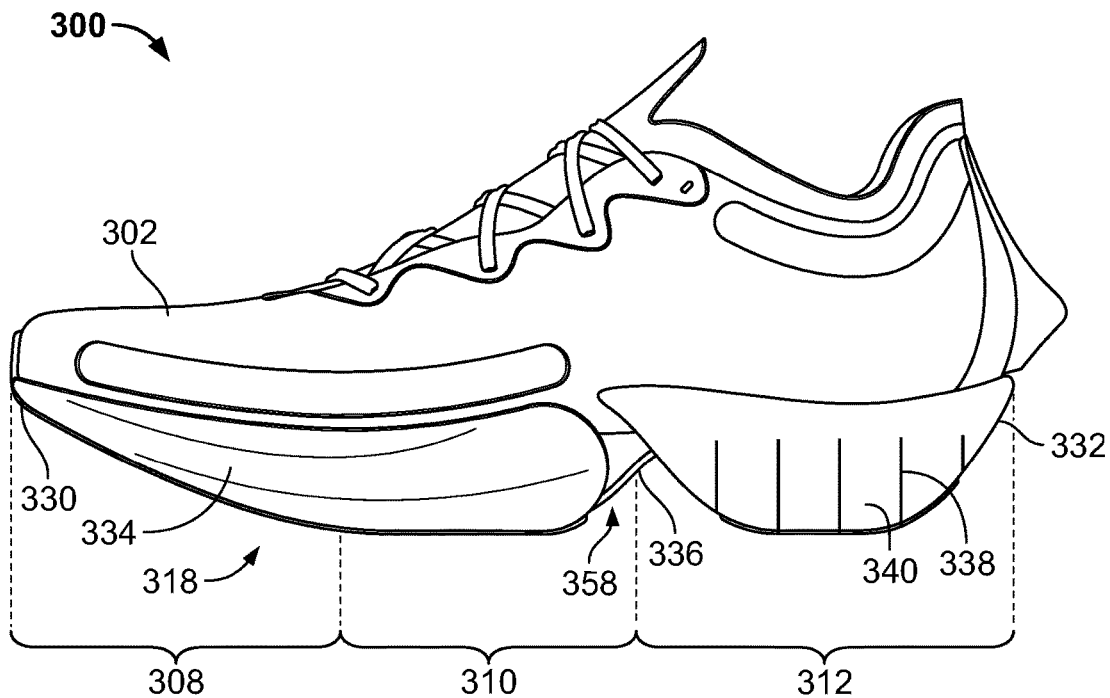

FIG. 29

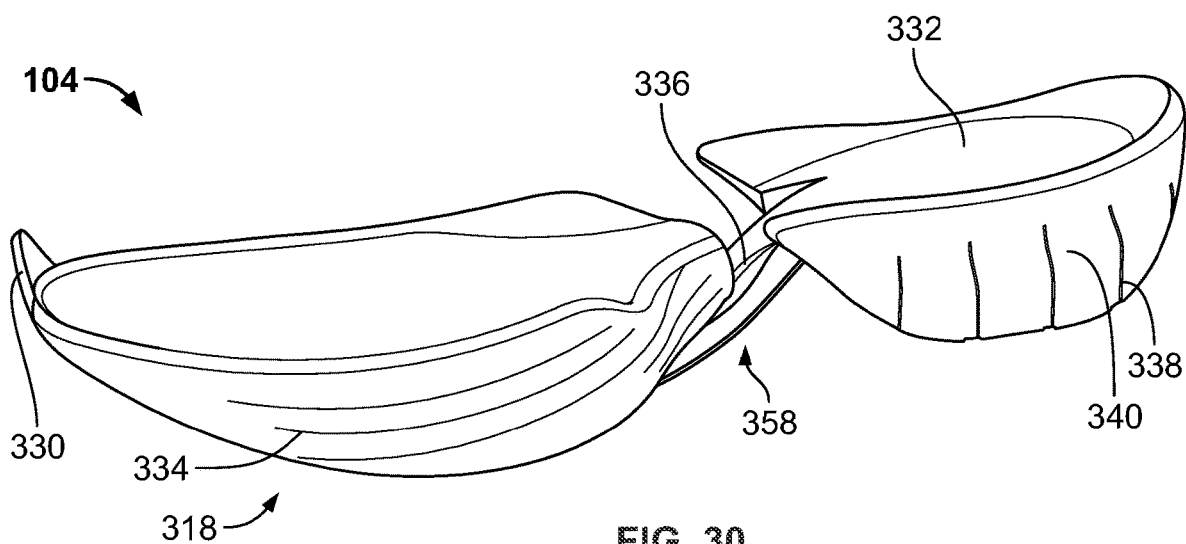

FIG. 30

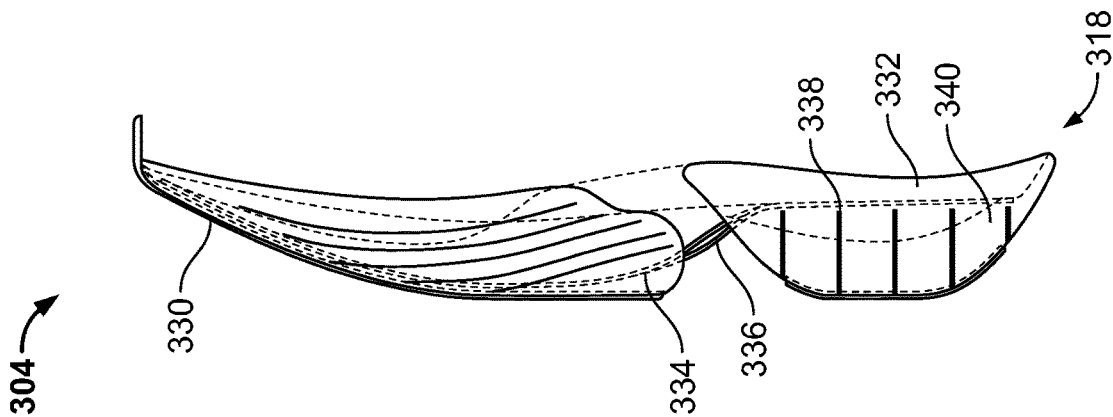

FIG. 31

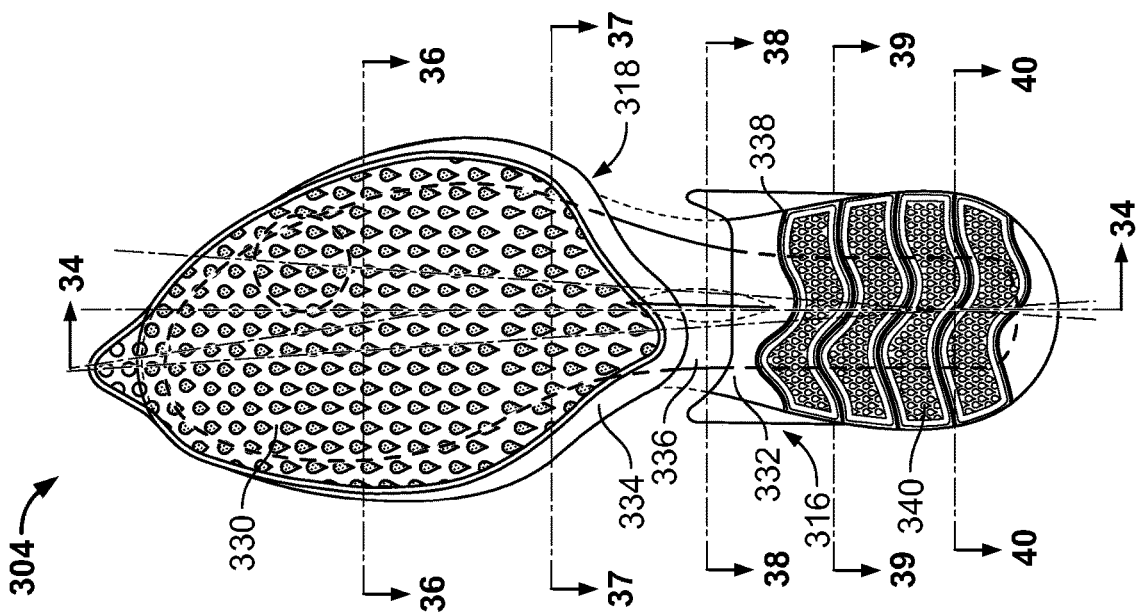

FIG. 32

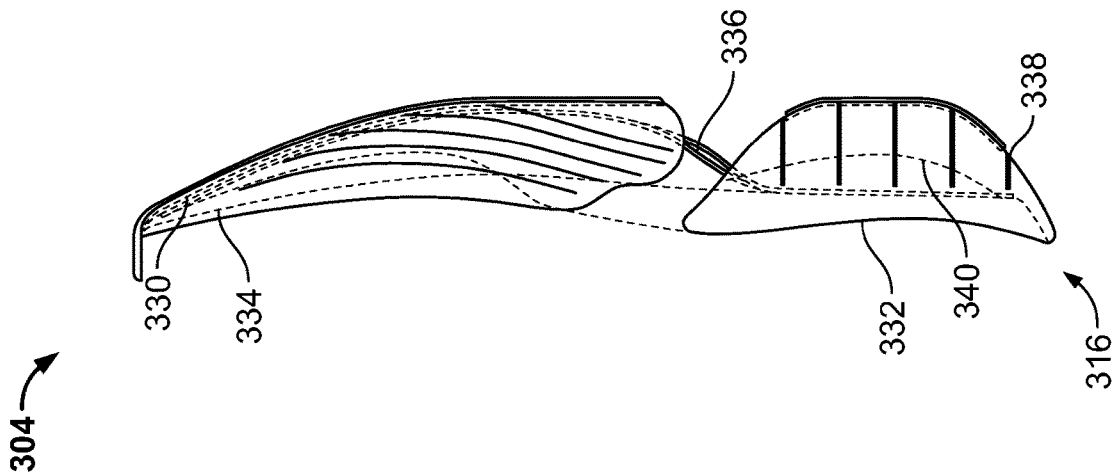

FIG. 33

304

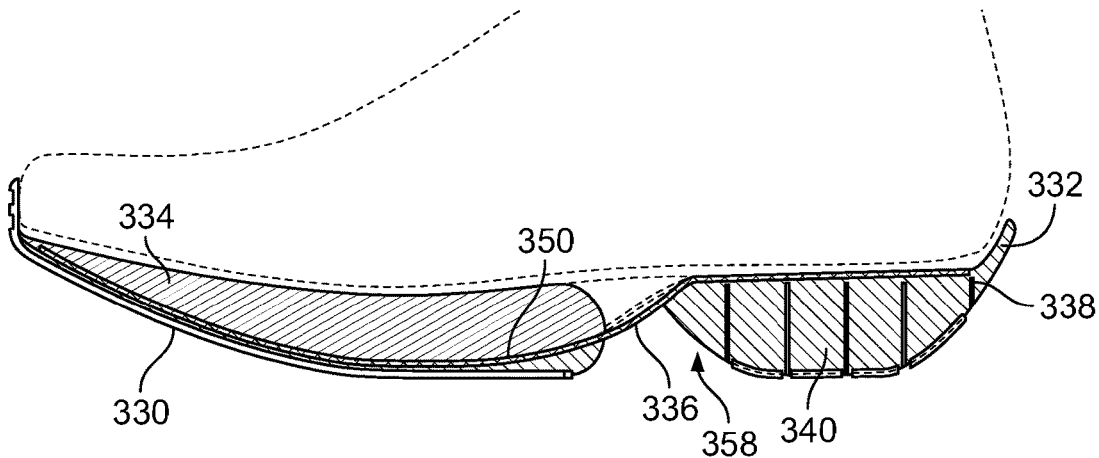

FIG. 34

304

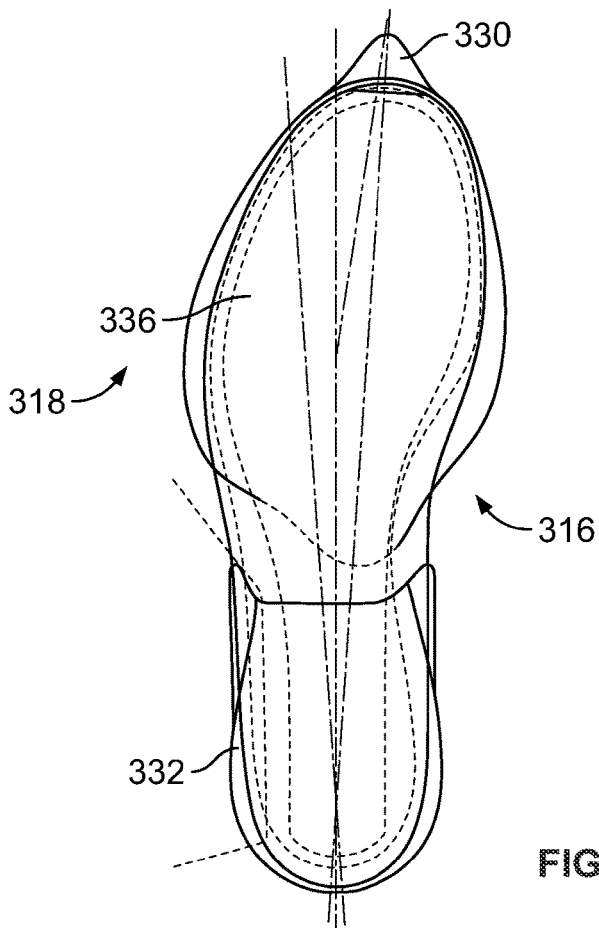

FIG. 35

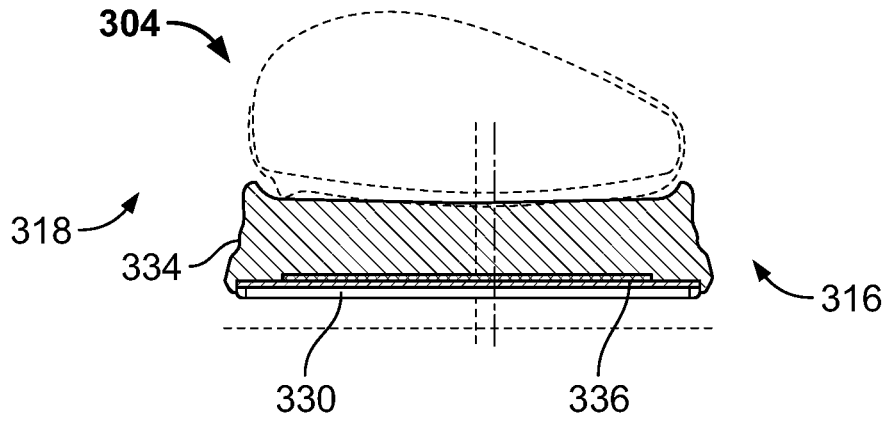

FIG. 36

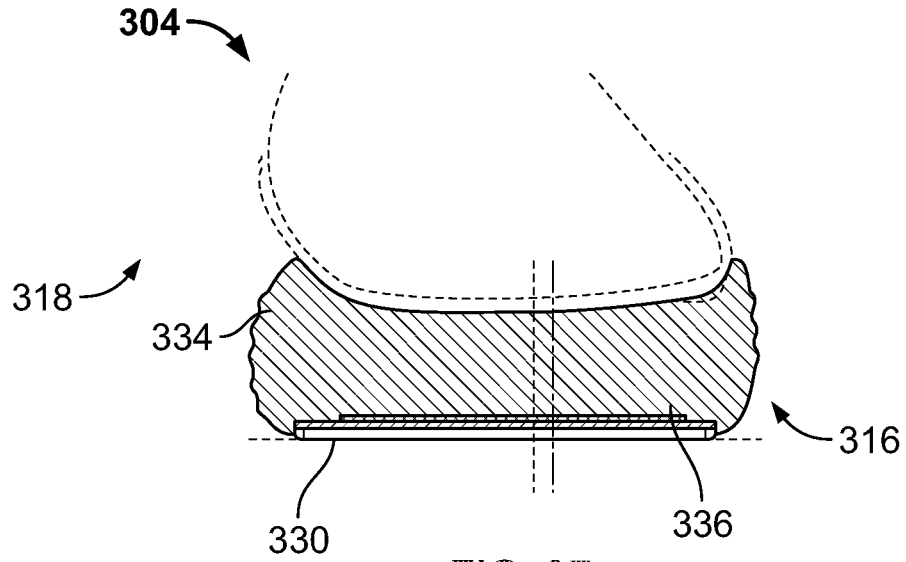

FIG. 37

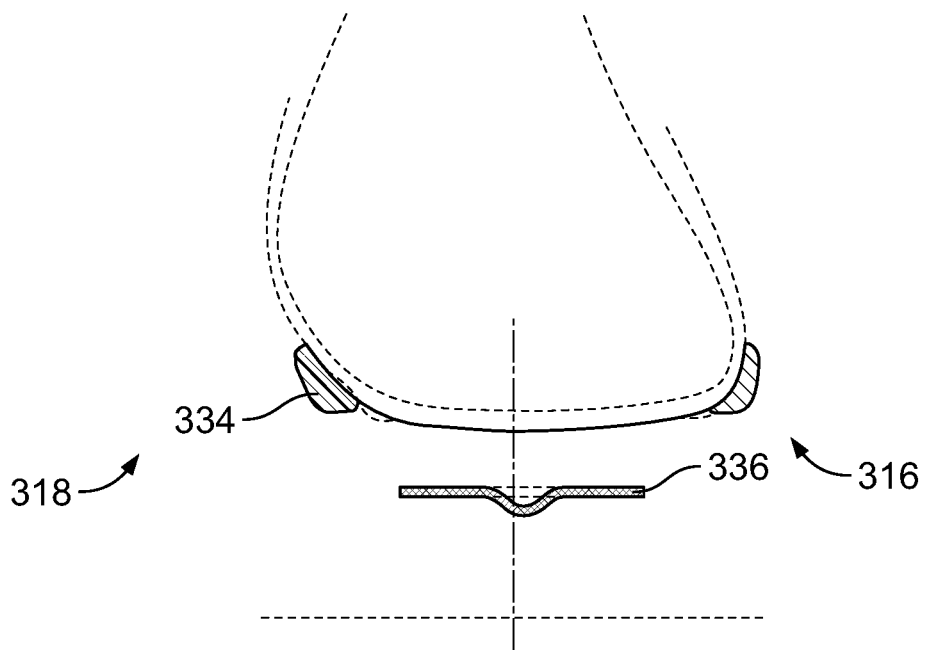

FIG. 38

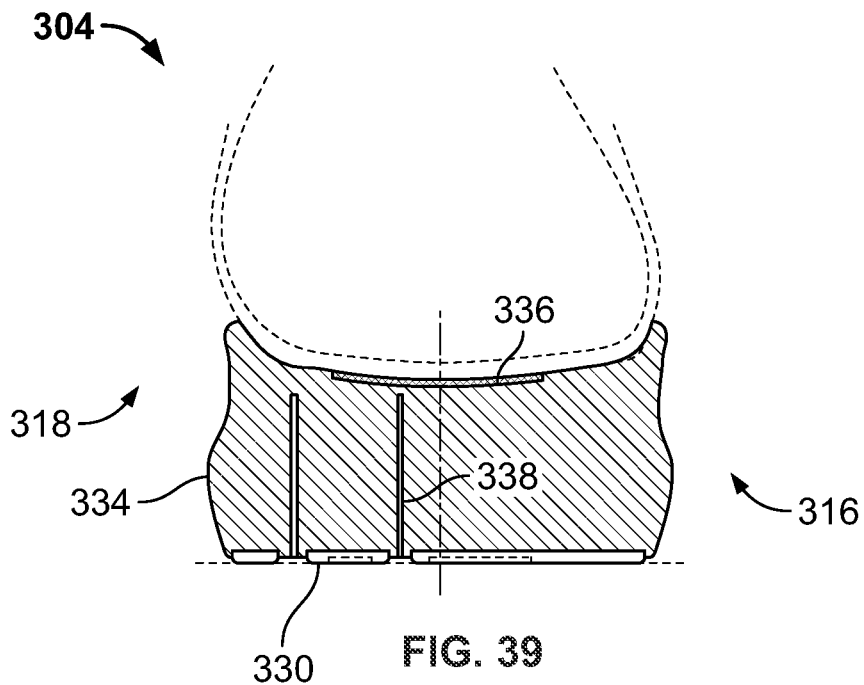

FIG. 39

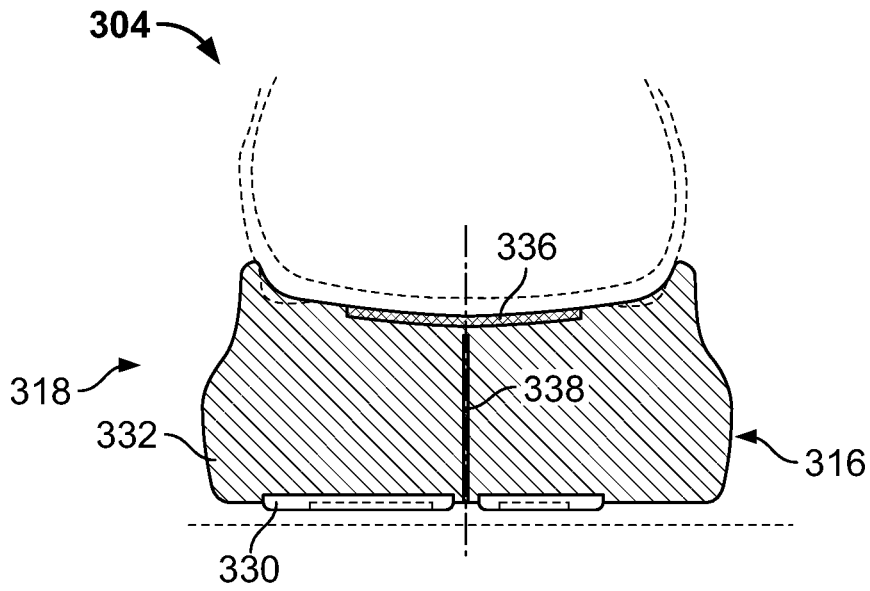

FIG. 40

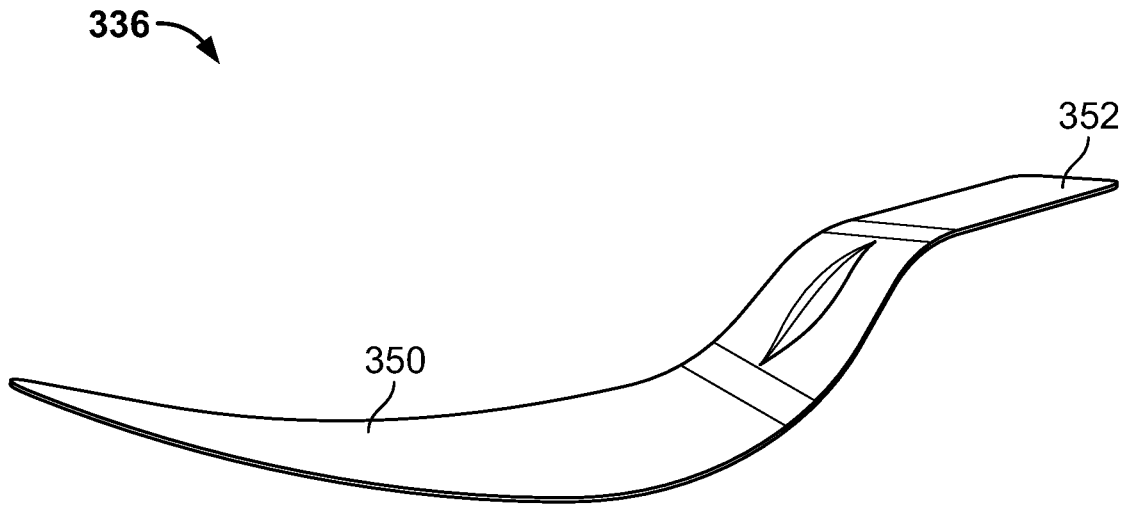

FIG. 41

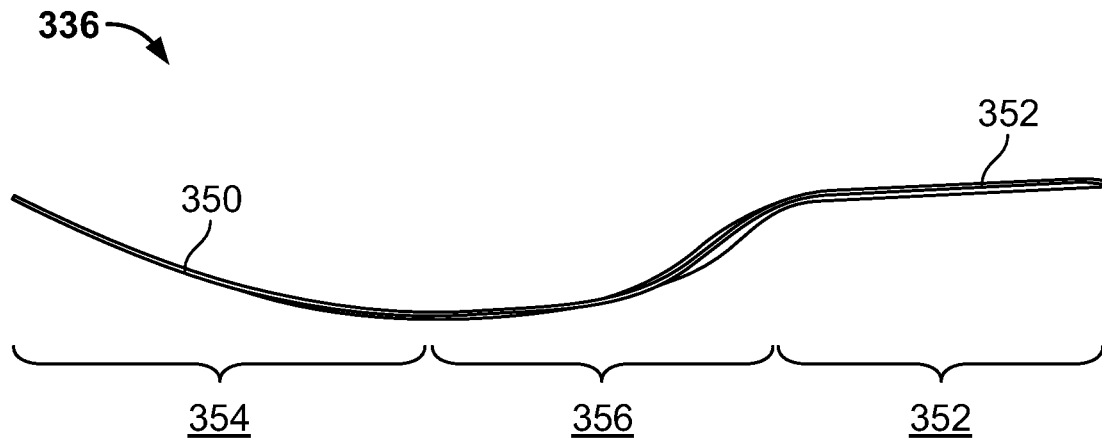

FIG. 42

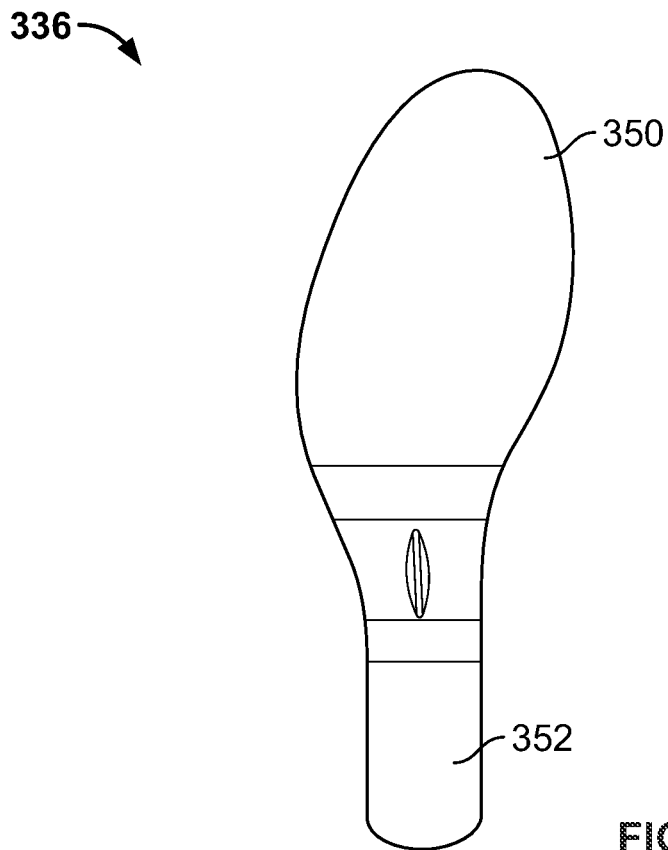

FIG. 43

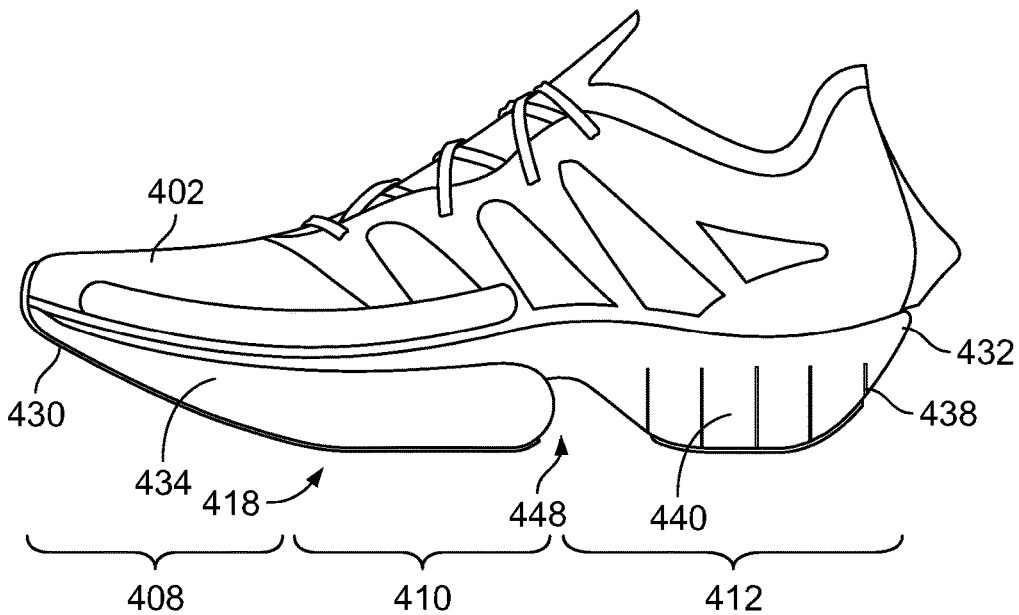

FIG. 44

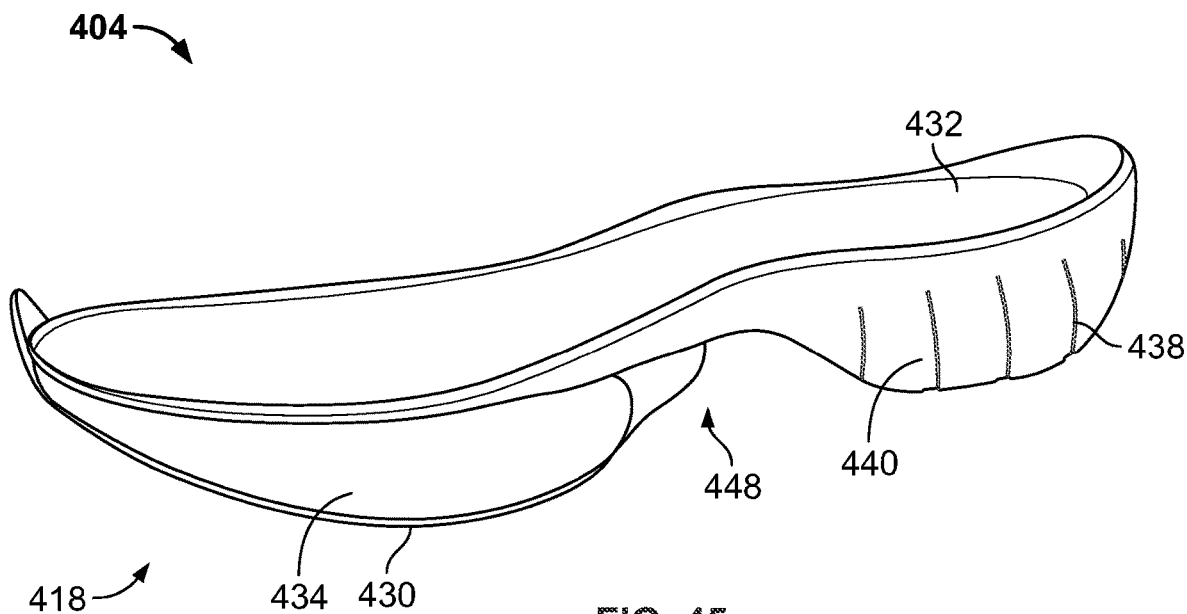

FIG. 45

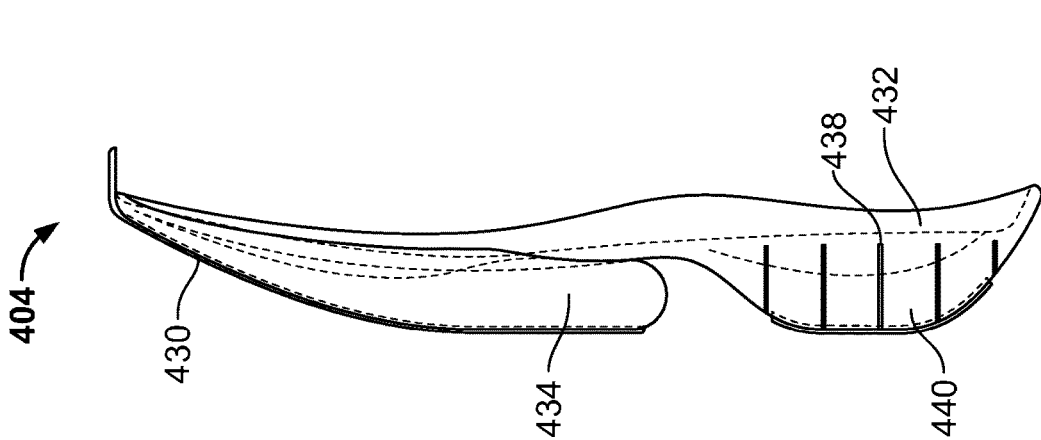

FIG. 46

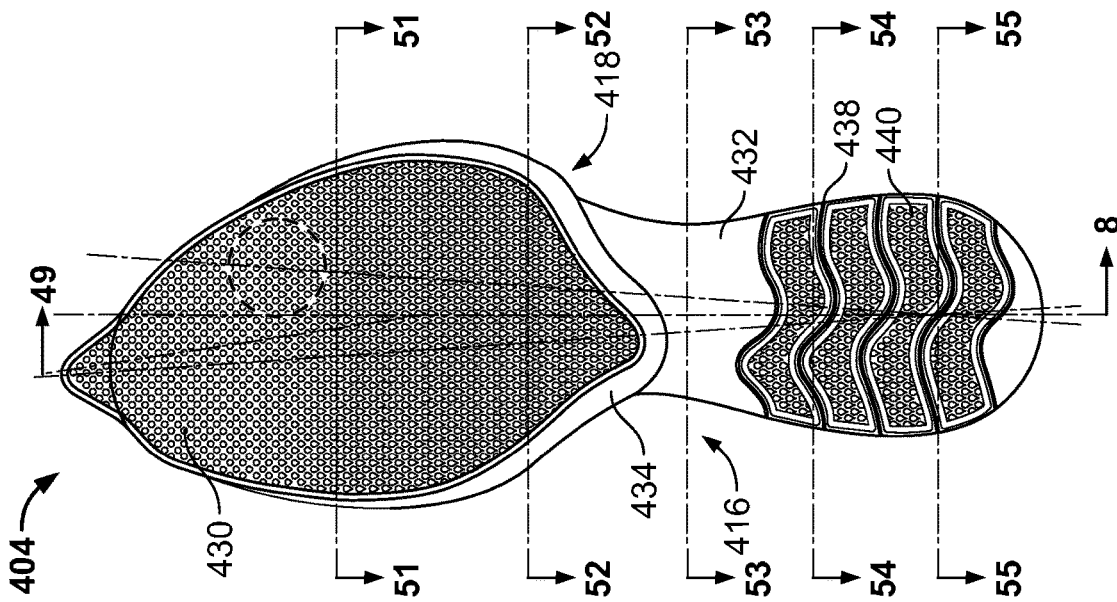

FIG. 47

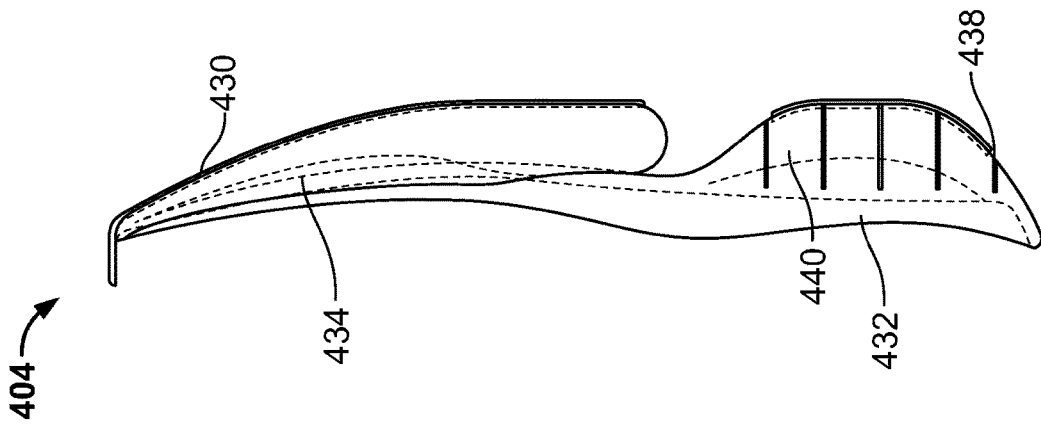

FIG. 48

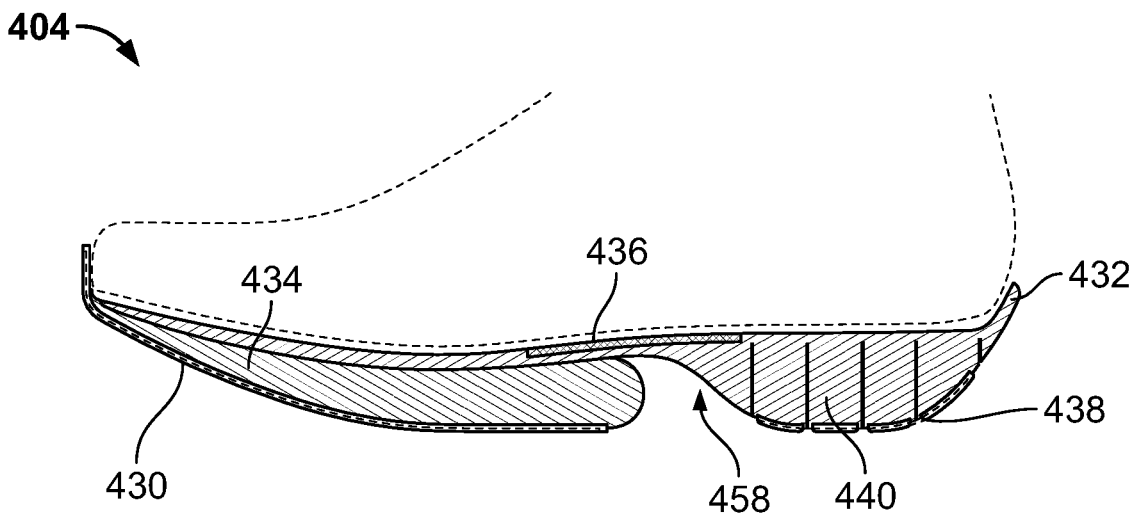

FIG. 49

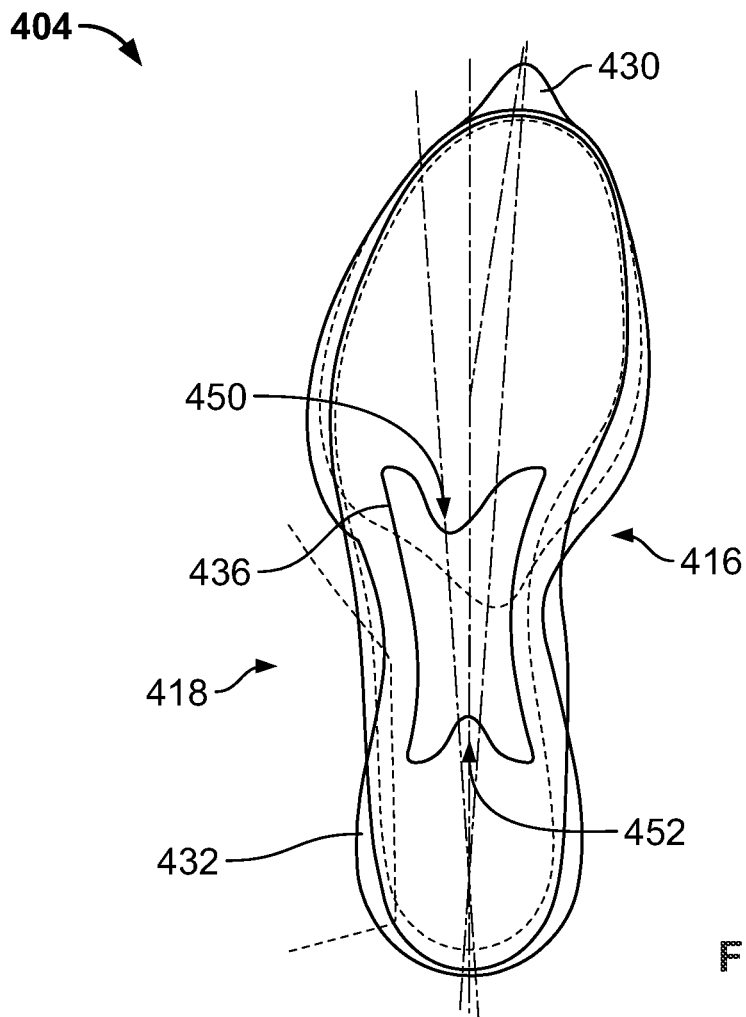

FIG. 50

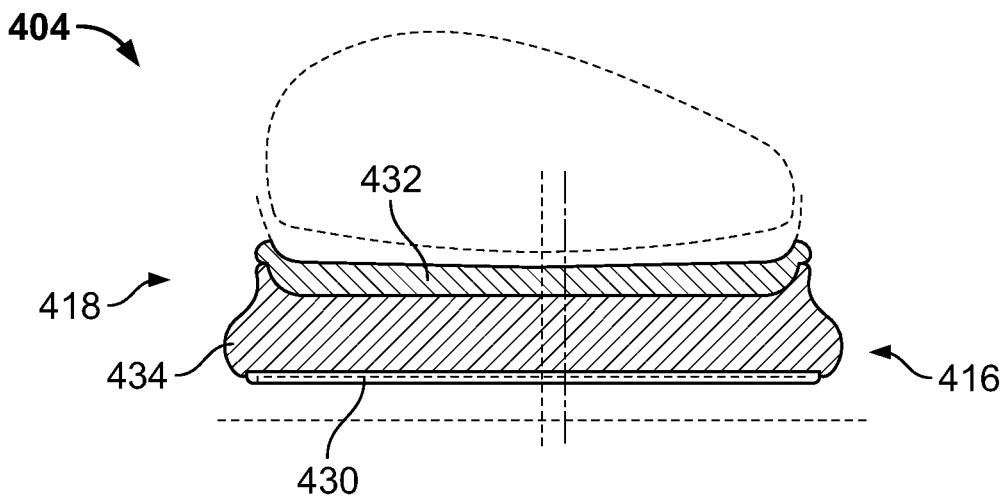

FIG. 51

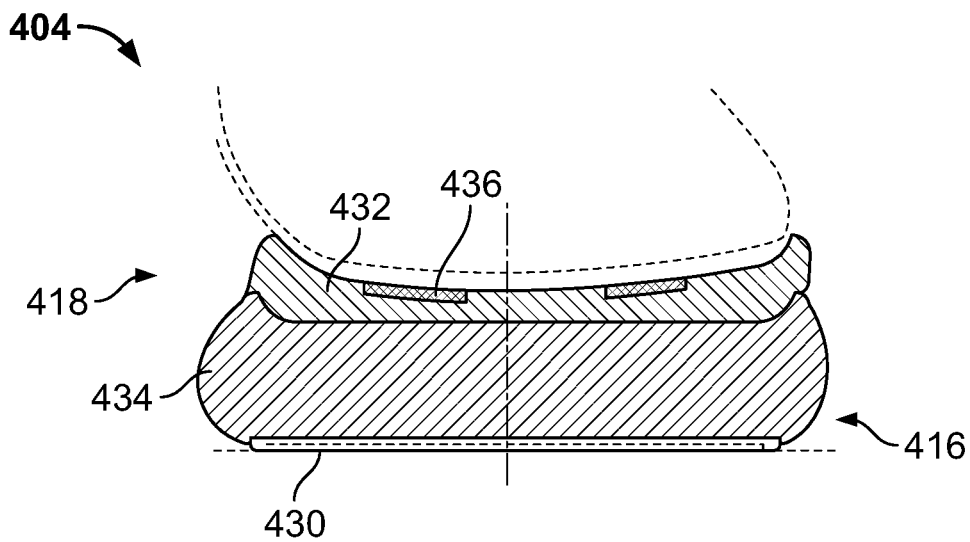

FIG. 52

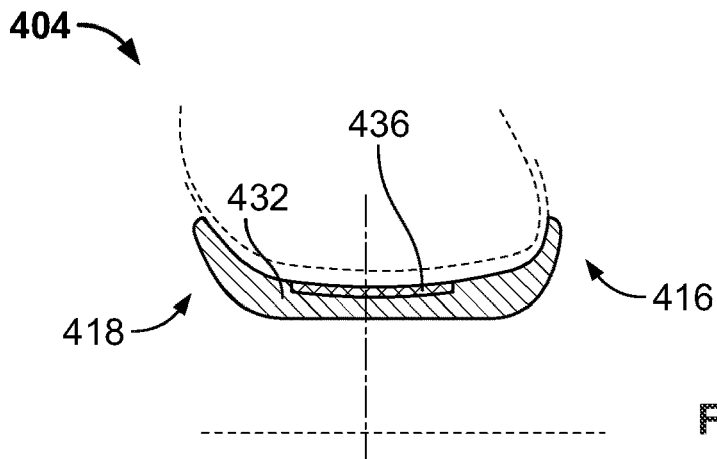

FIG. 53

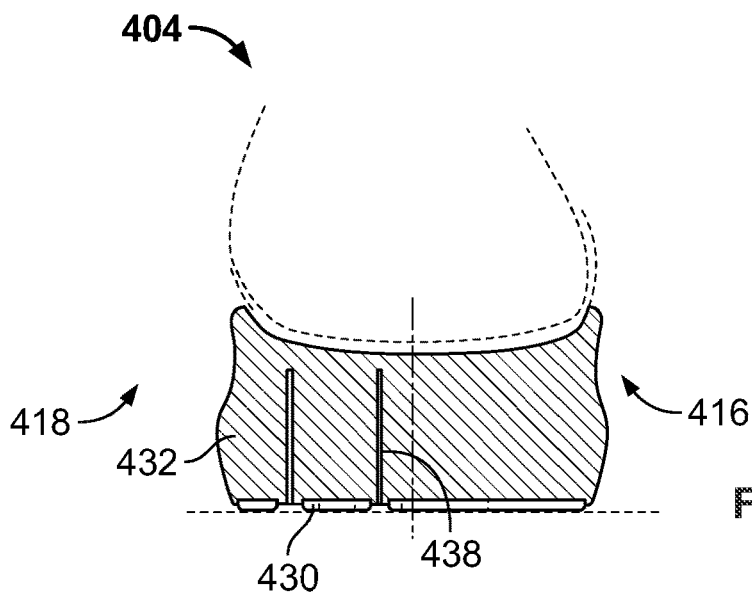

FIG. 54

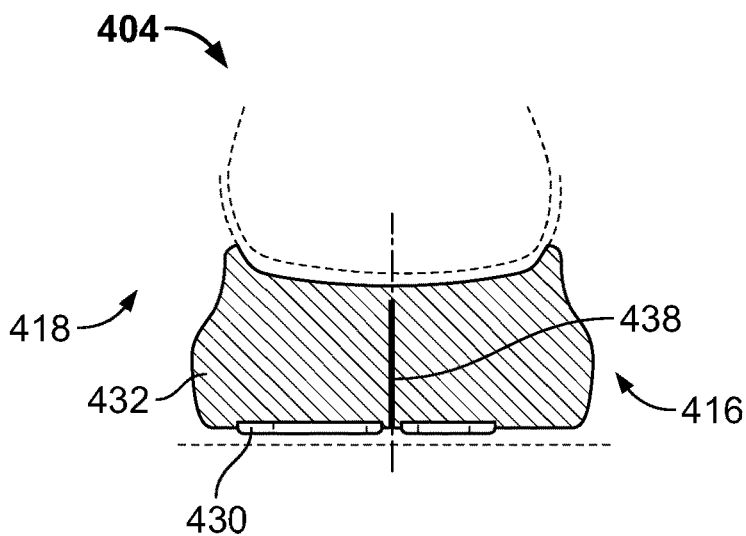
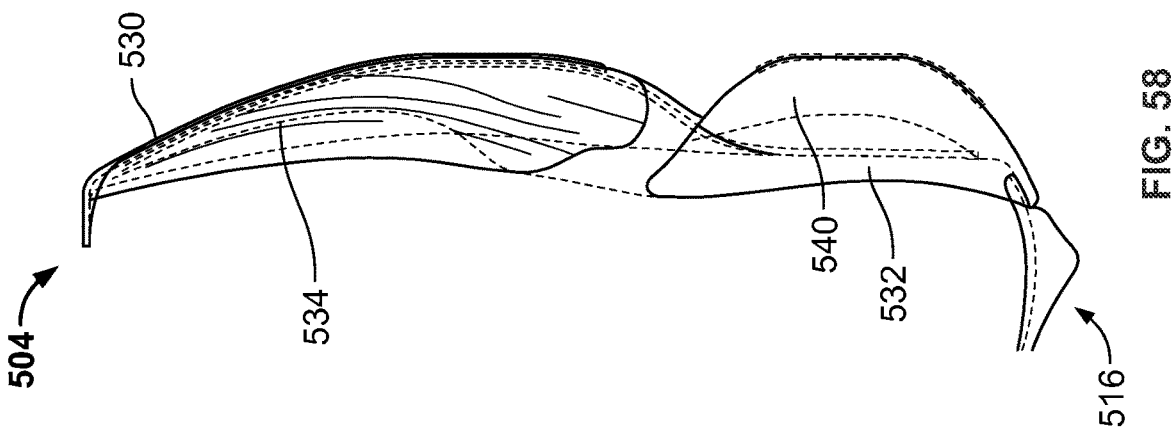
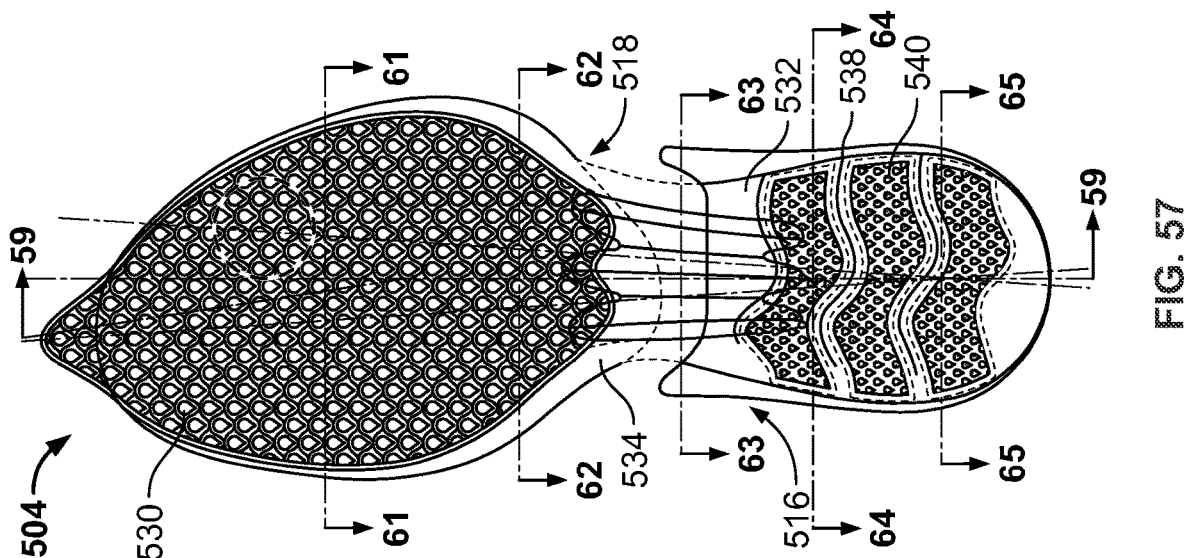
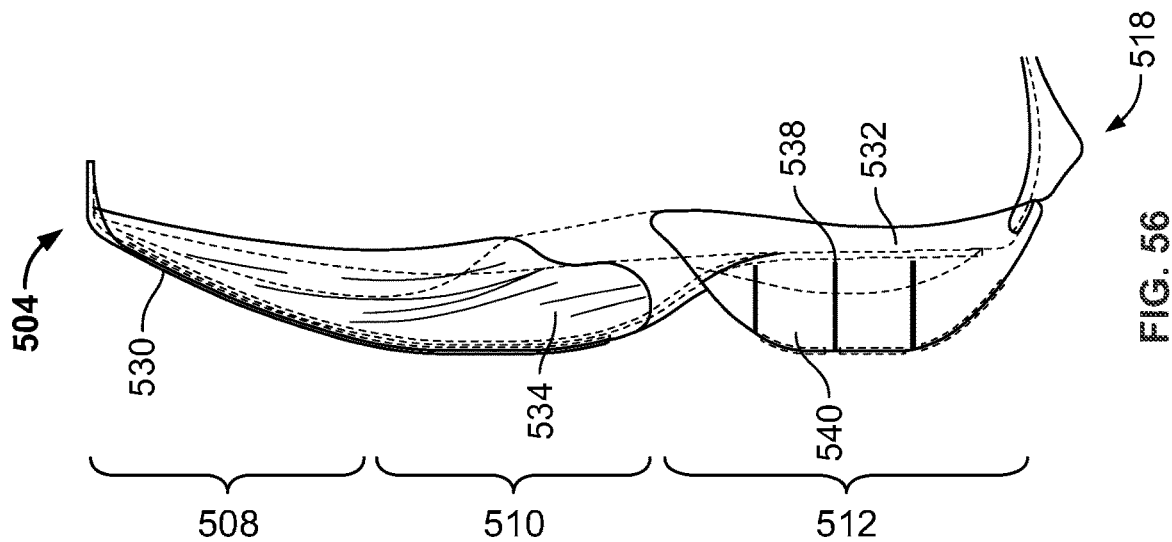

FIG. 55



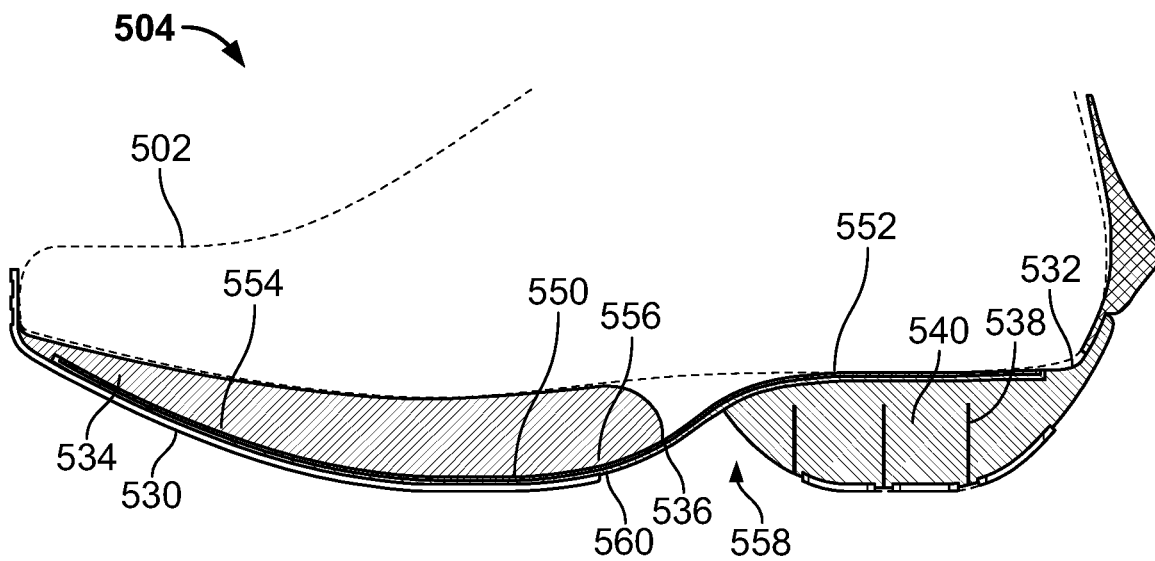

FIG. 59

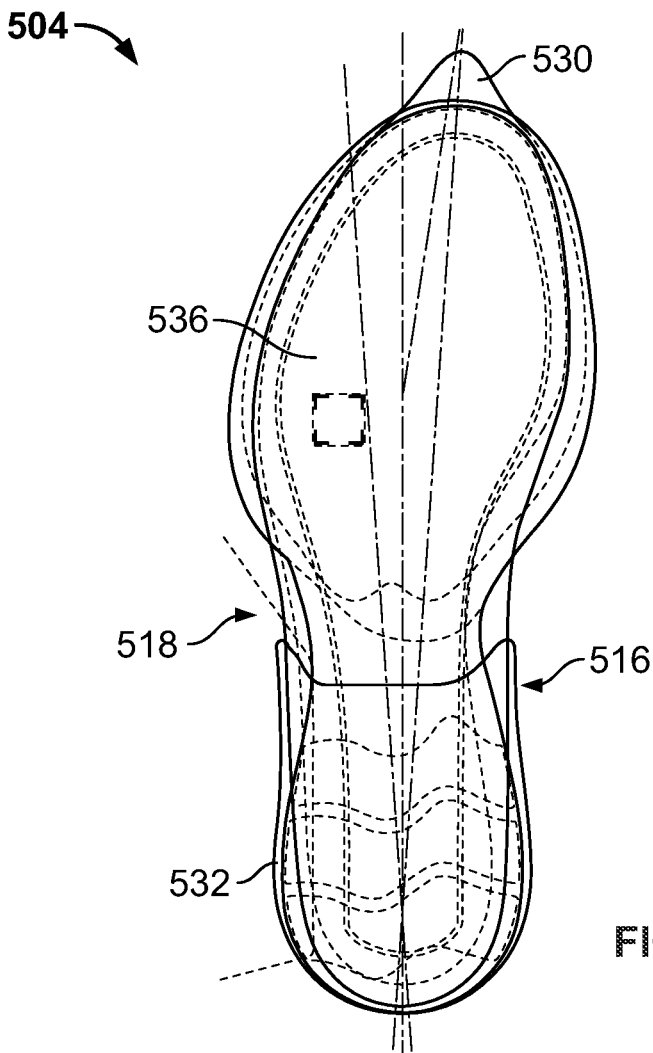

FIG. 60

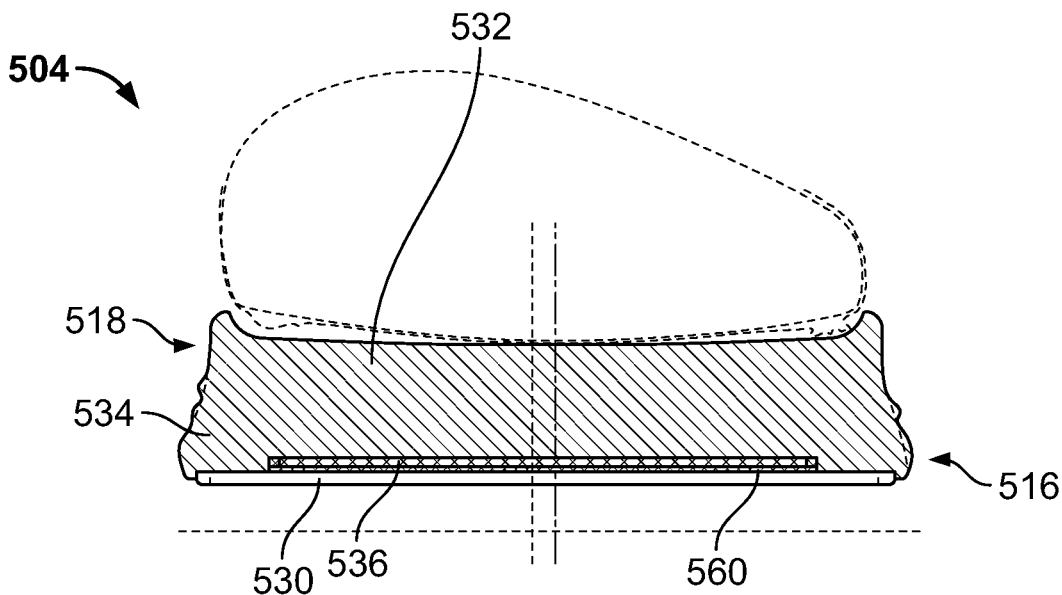

FIG. 61

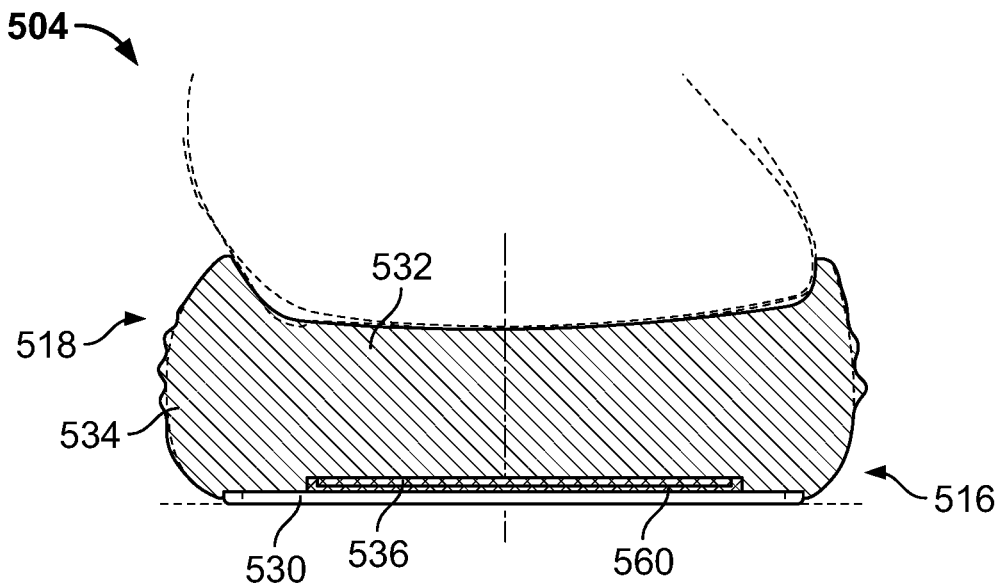

FIG. 62

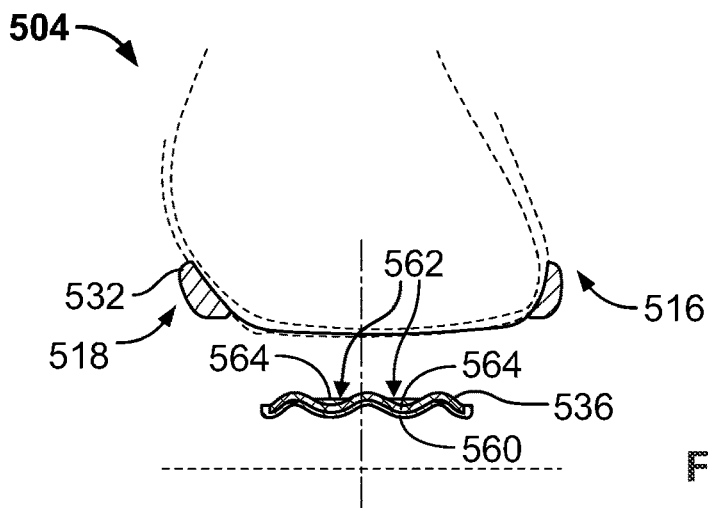

FIG. 63

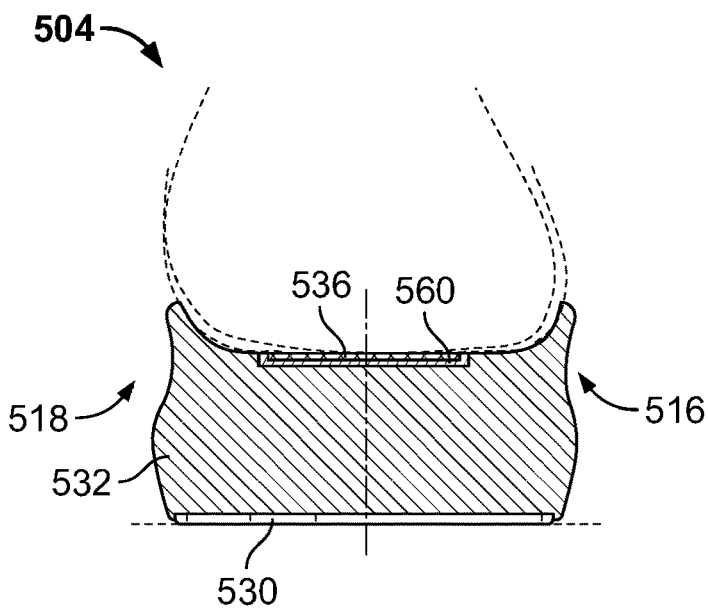

FIG. 64

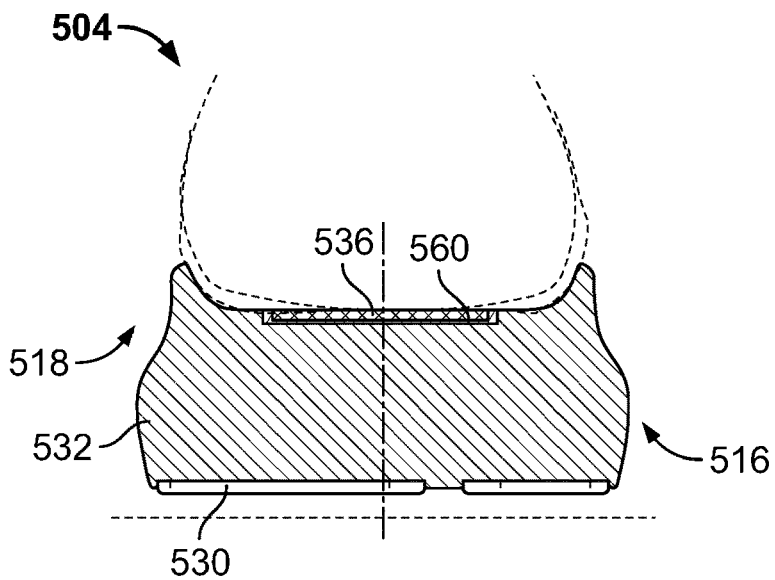

FIG. 65

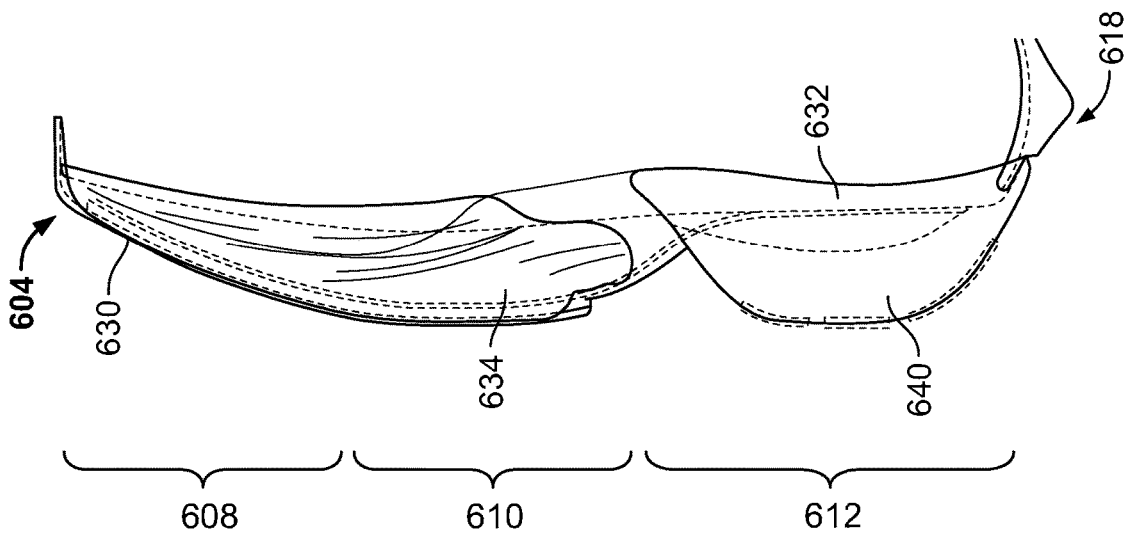

FIG. 66

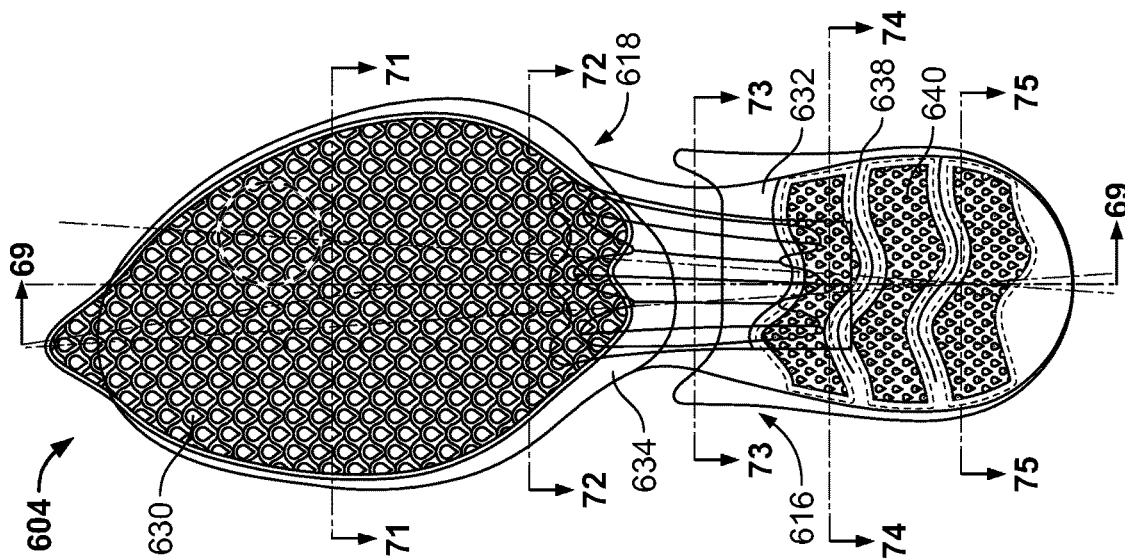

FIG. 67

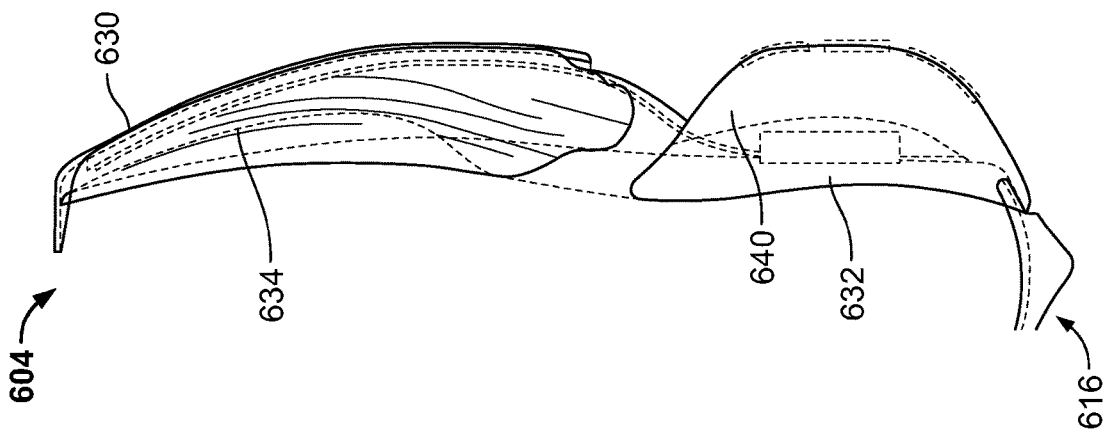
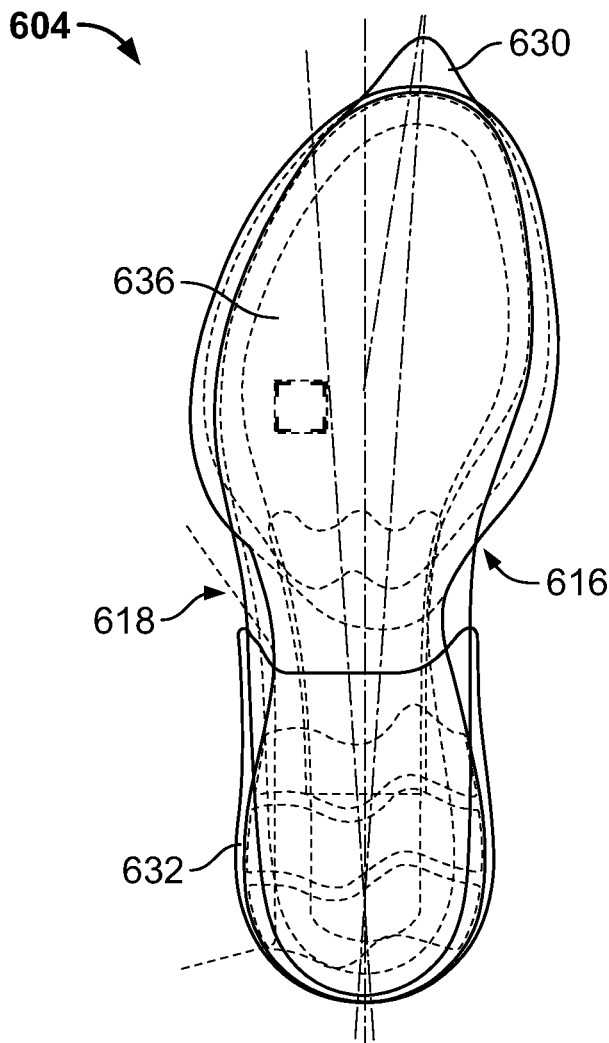
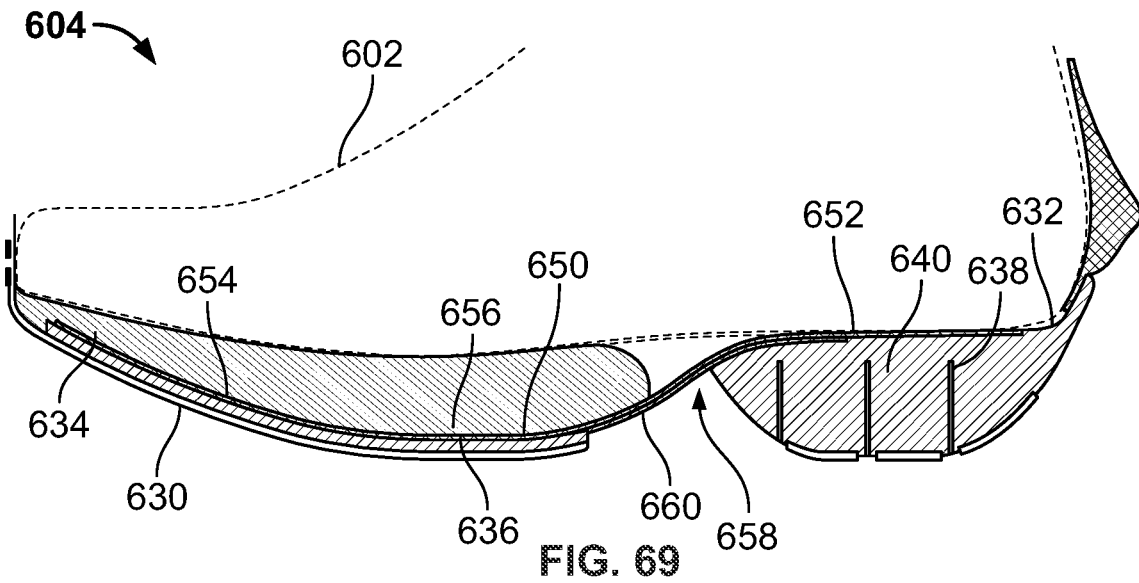

FIG. 68



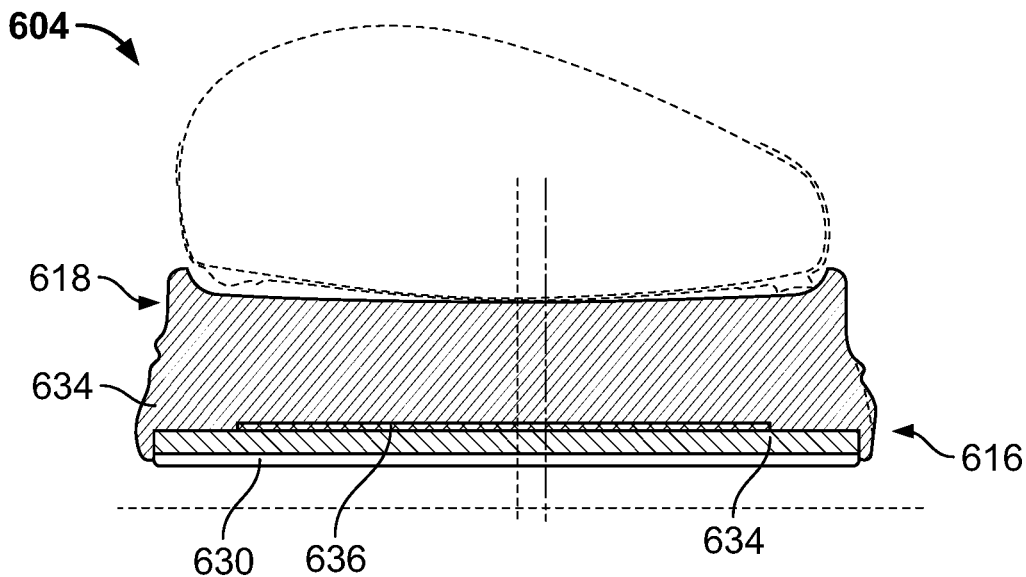

FIG. 71

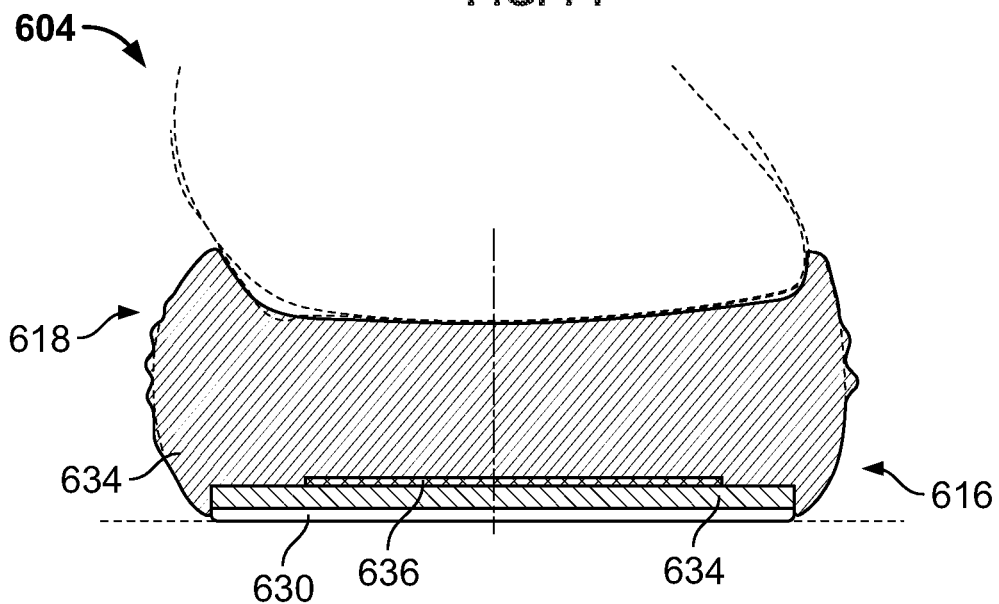

FIG. 72

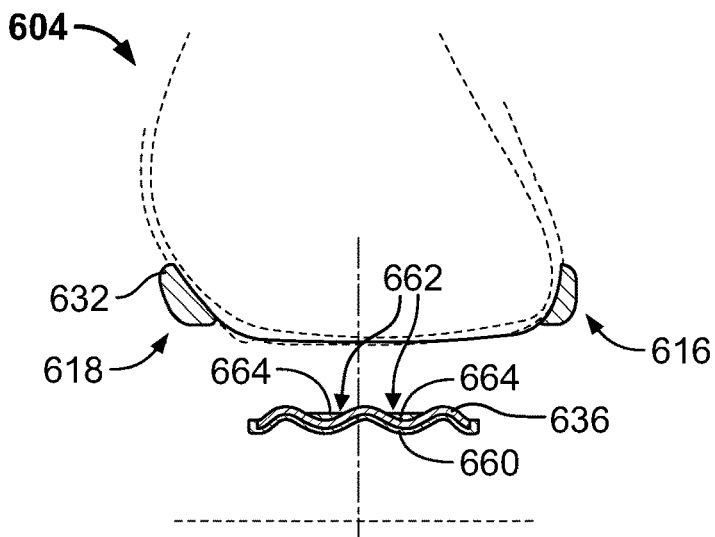

FIG. 73

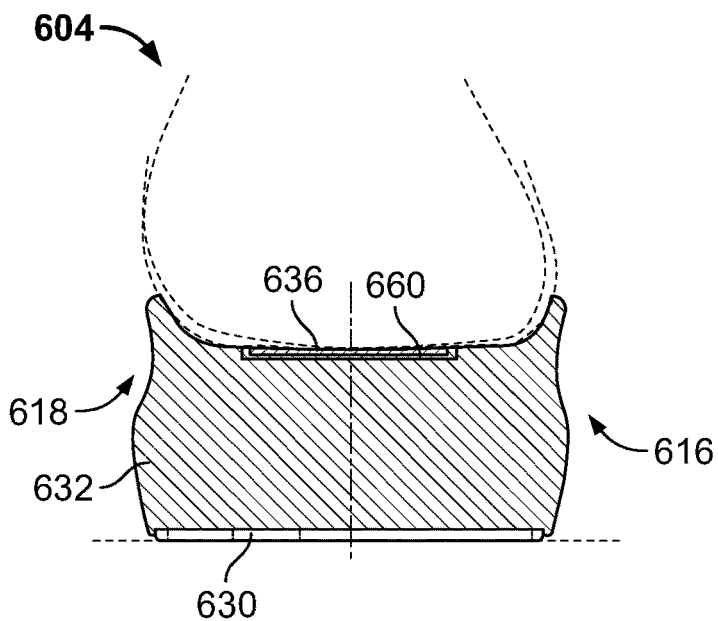

FIG. 74

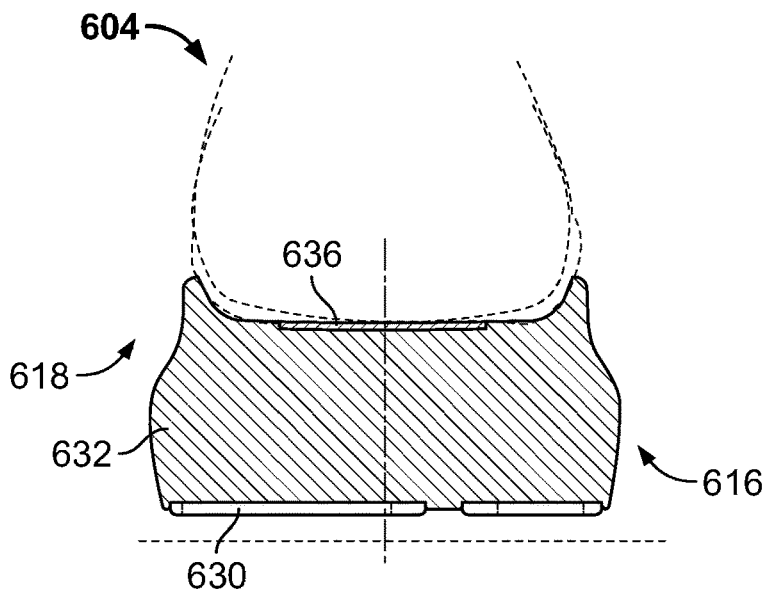

FIG. 75

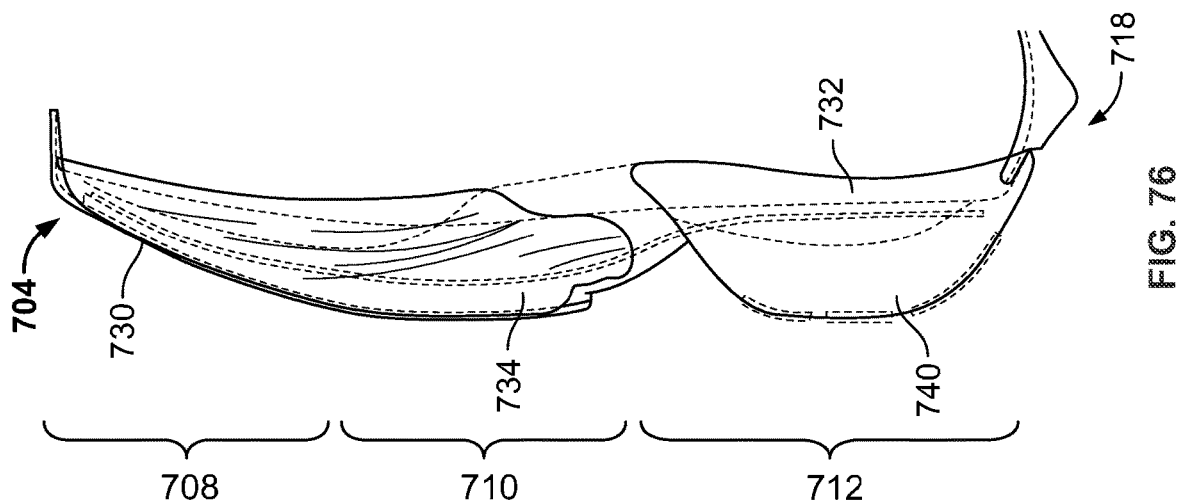

FIG. 76

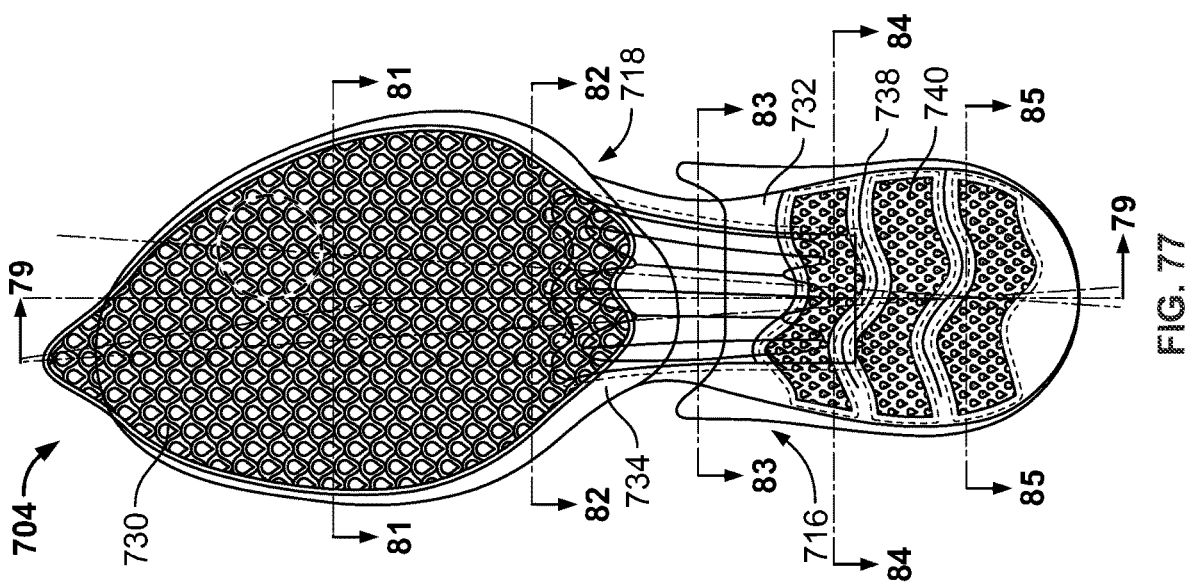

FIG. 77

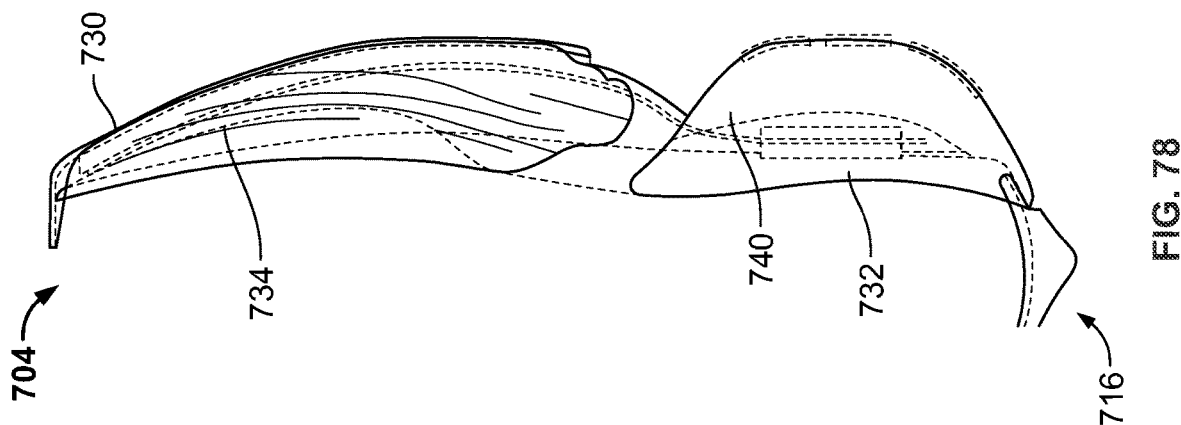

FIG. 78

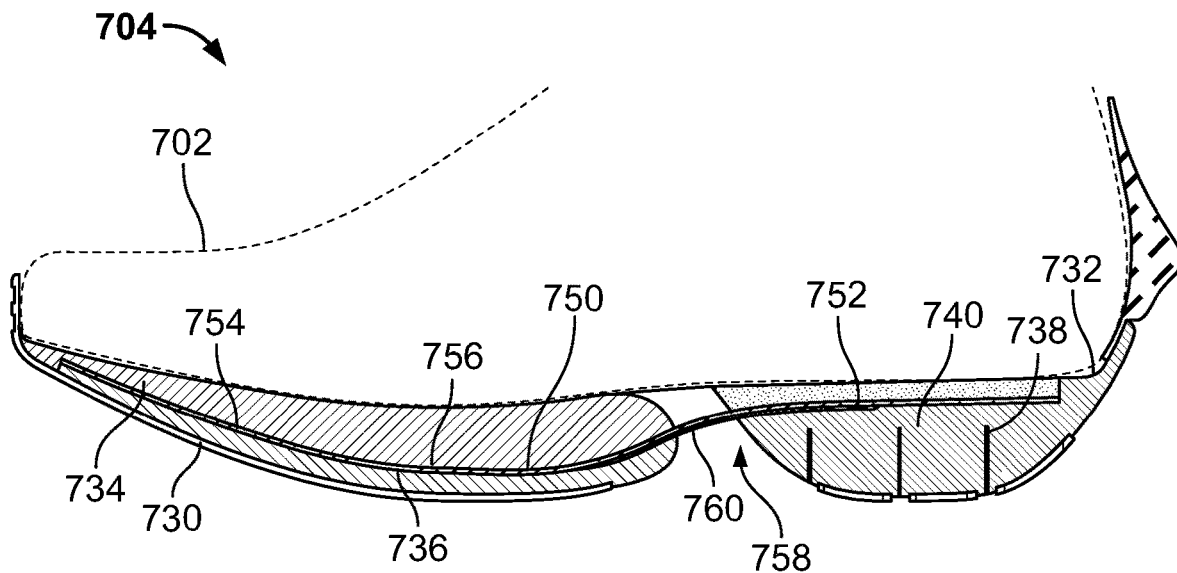

FIG. 79

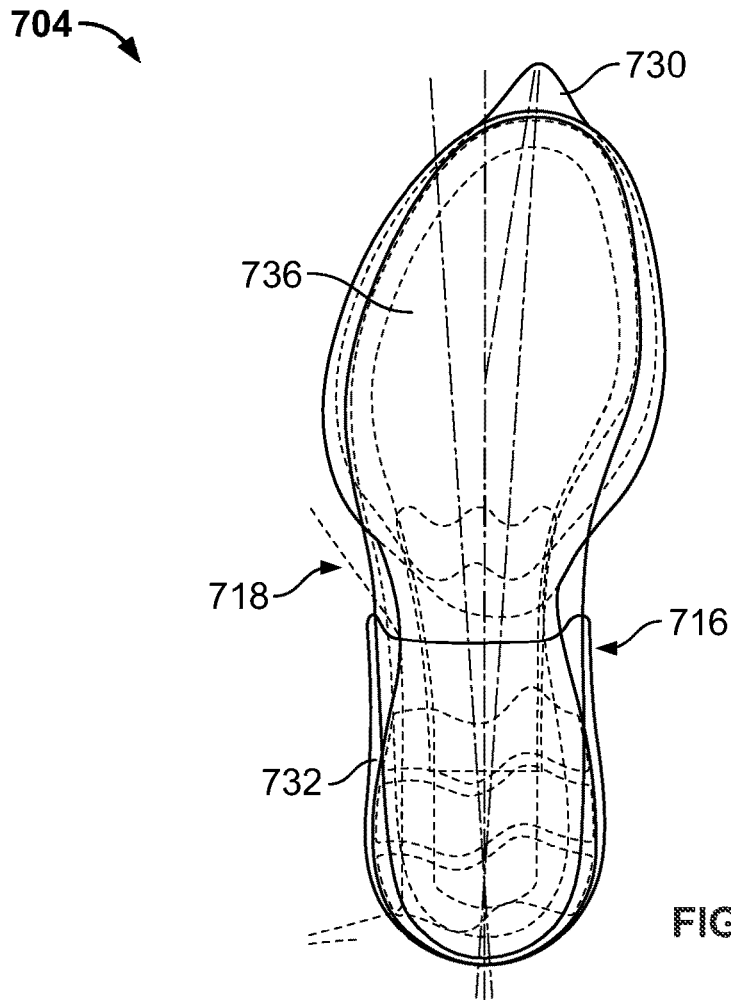

FIG. 80

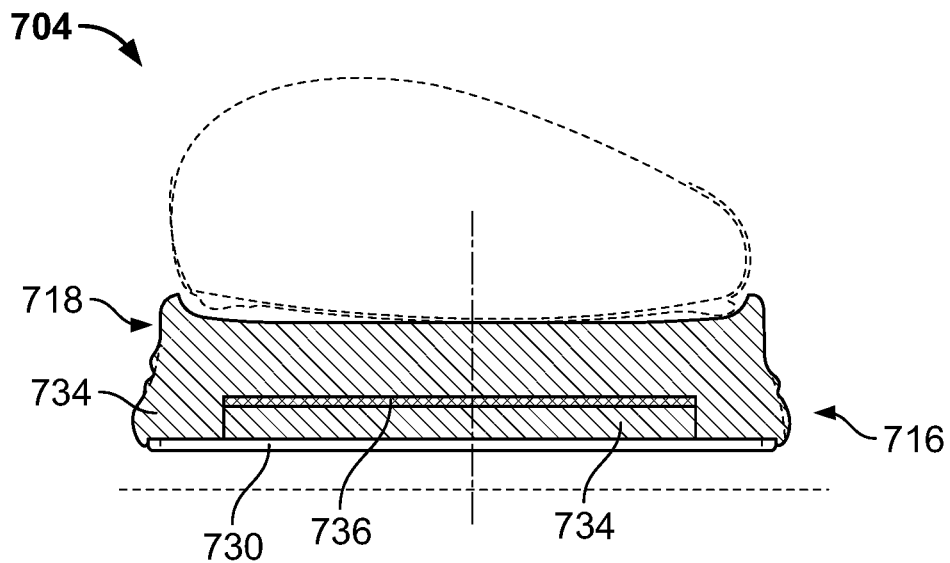

FIG. 81

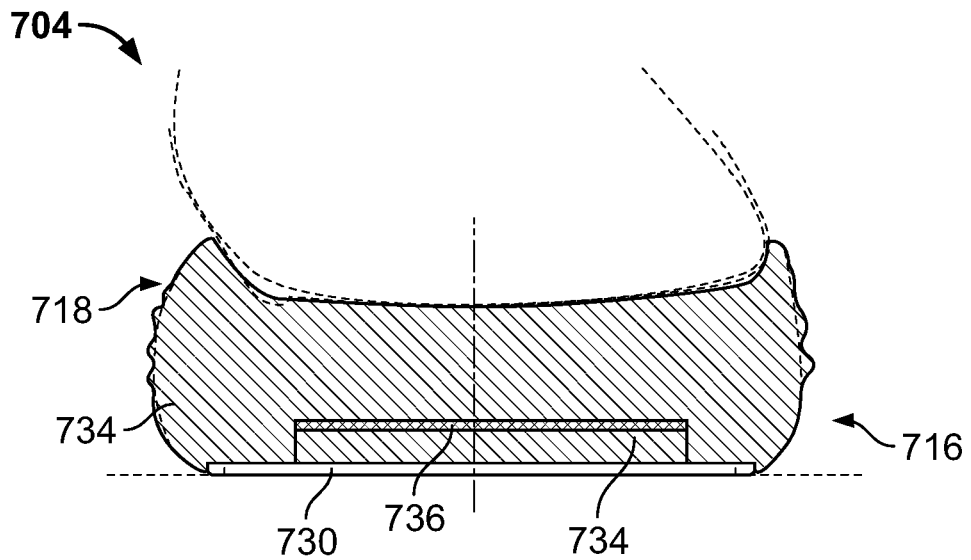

FIG. 82

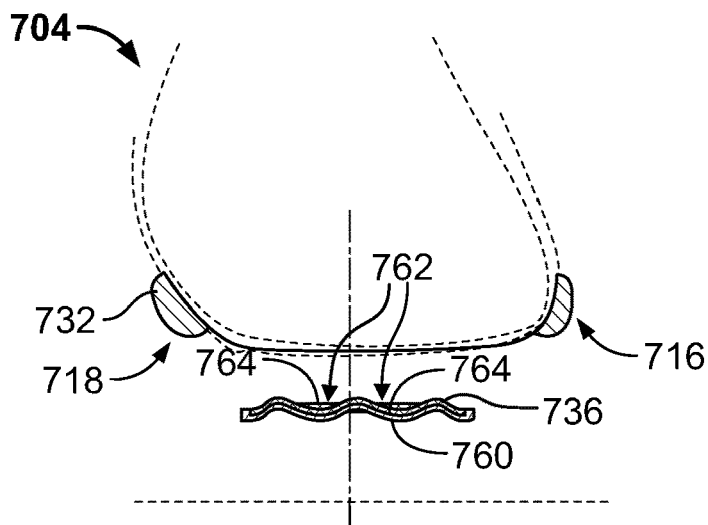

FIG. 83

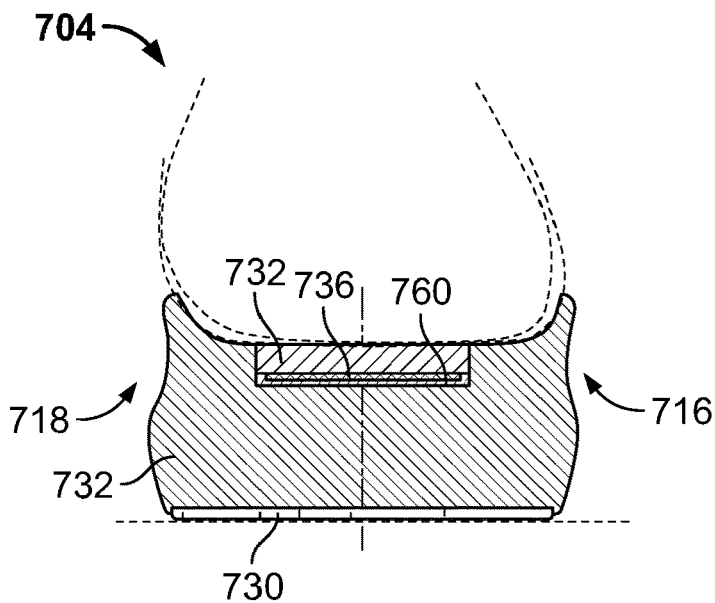

FIG. 84

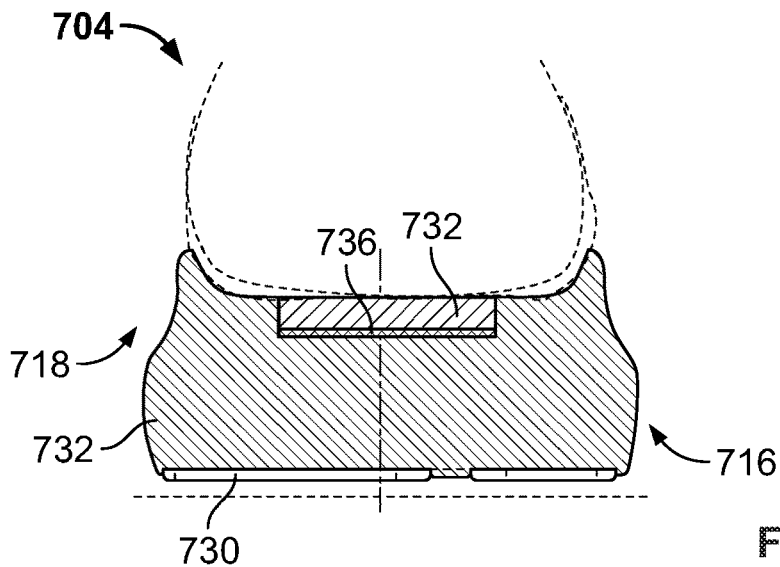

FIG. 85

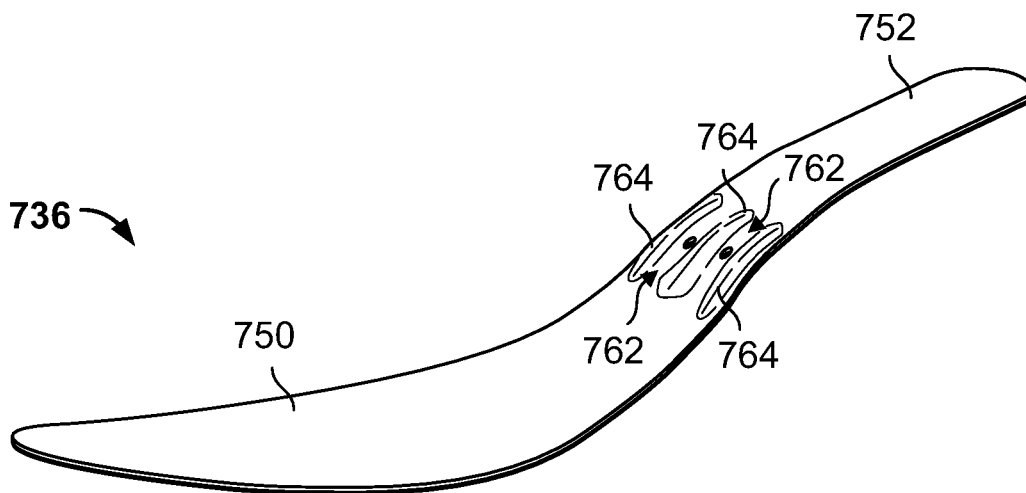

FIG. 86

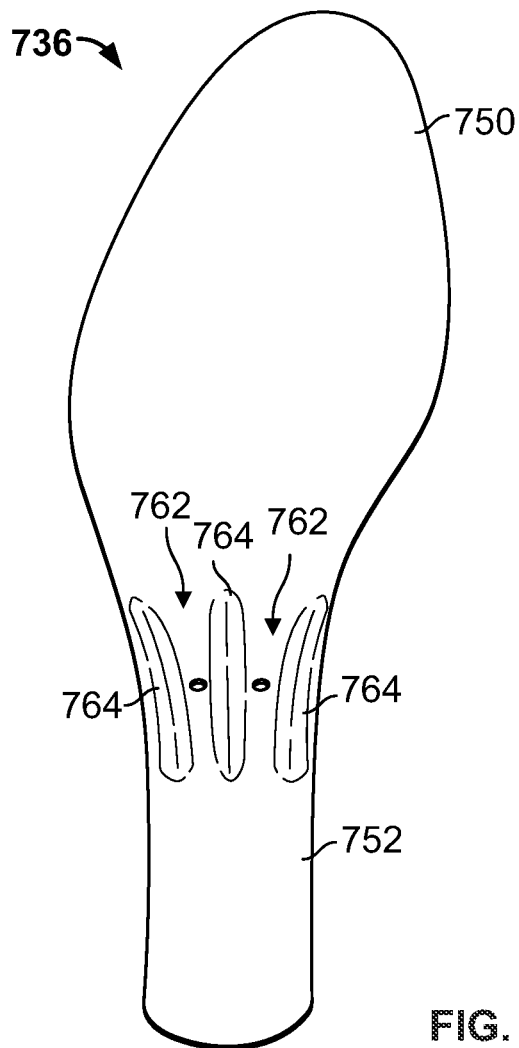

FIG. 87

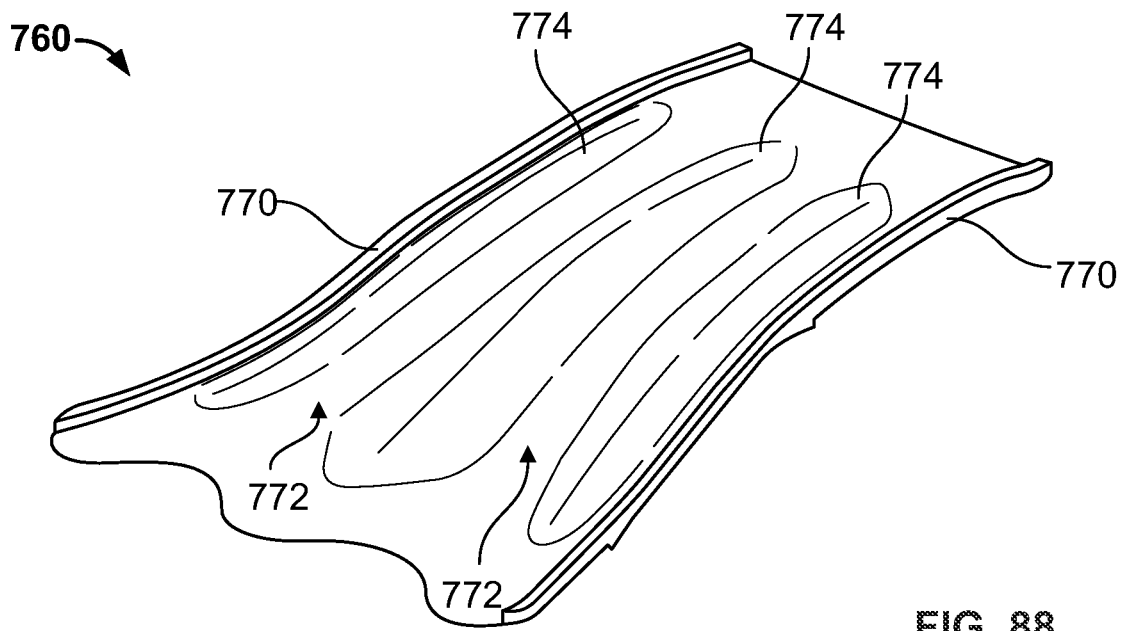

FIG. 88

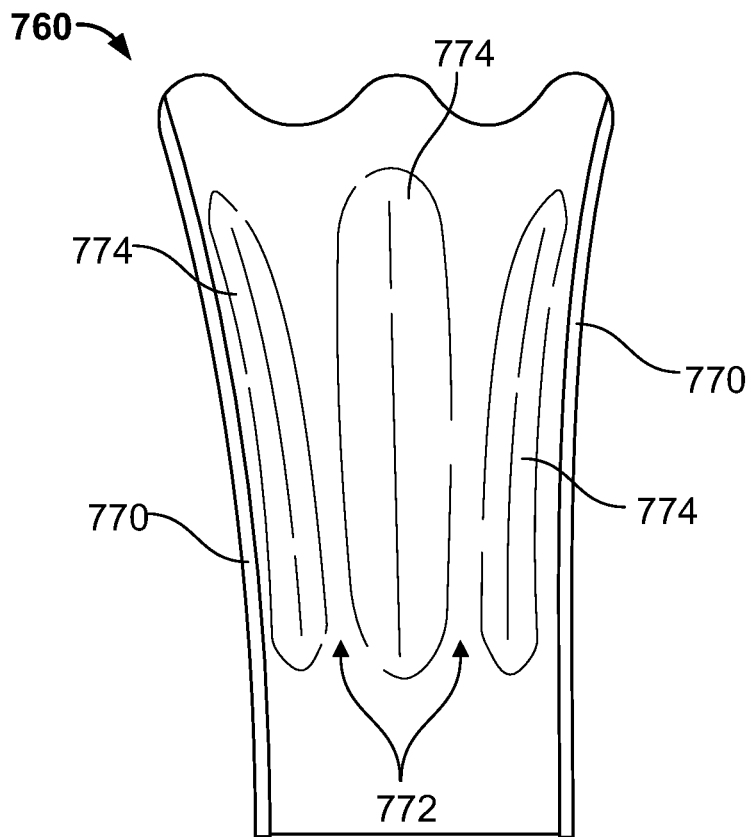

FIG. 89

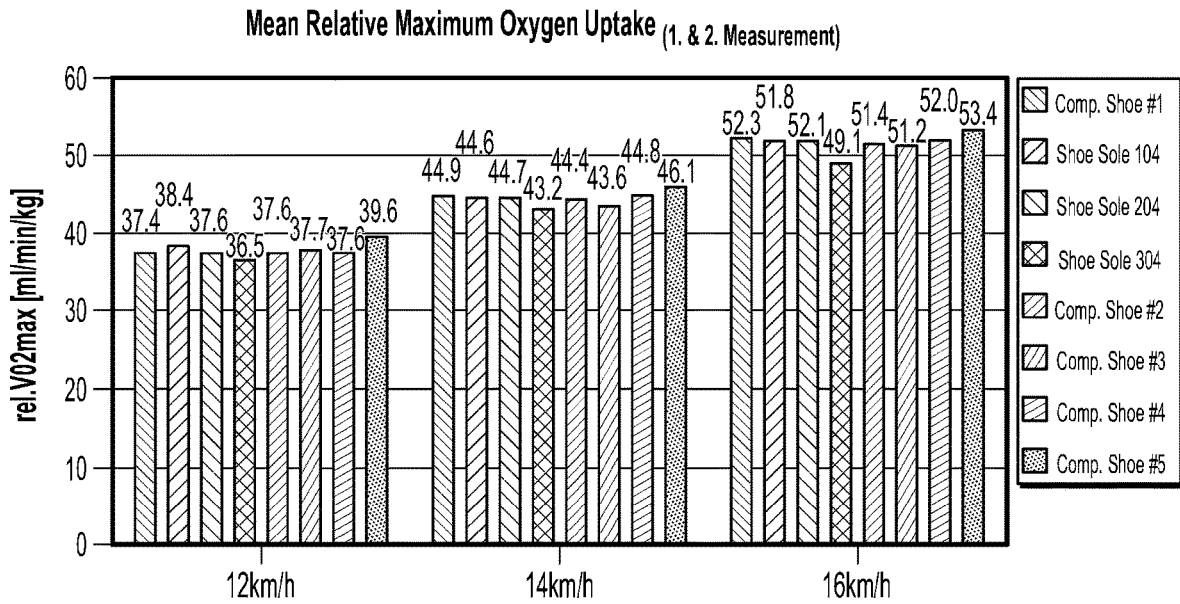

FIG. 90

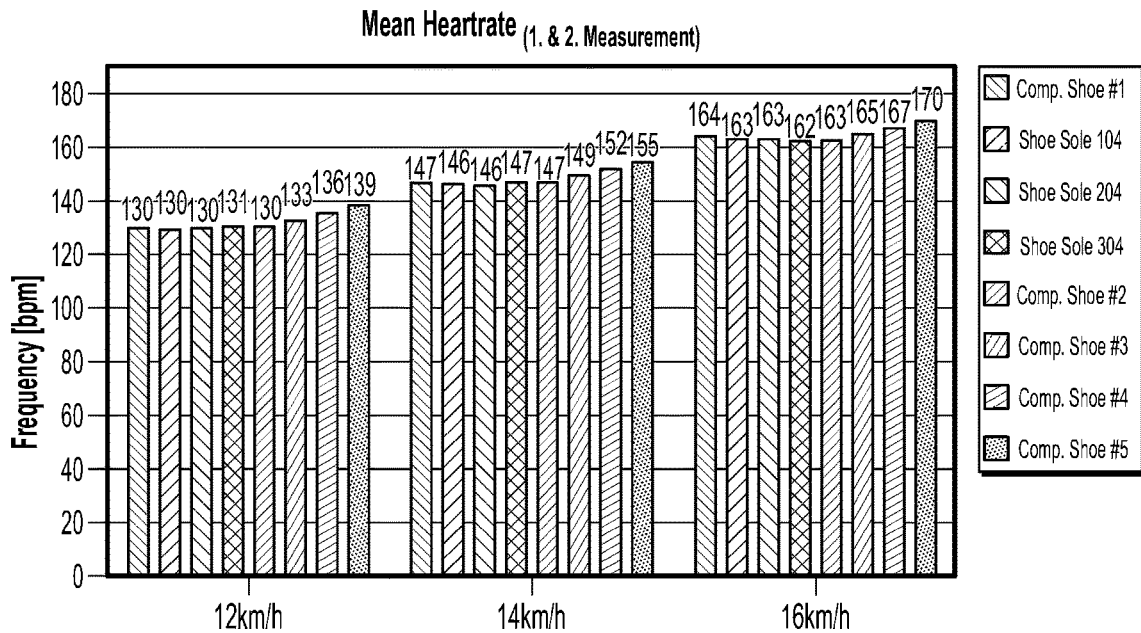

FIG. 91

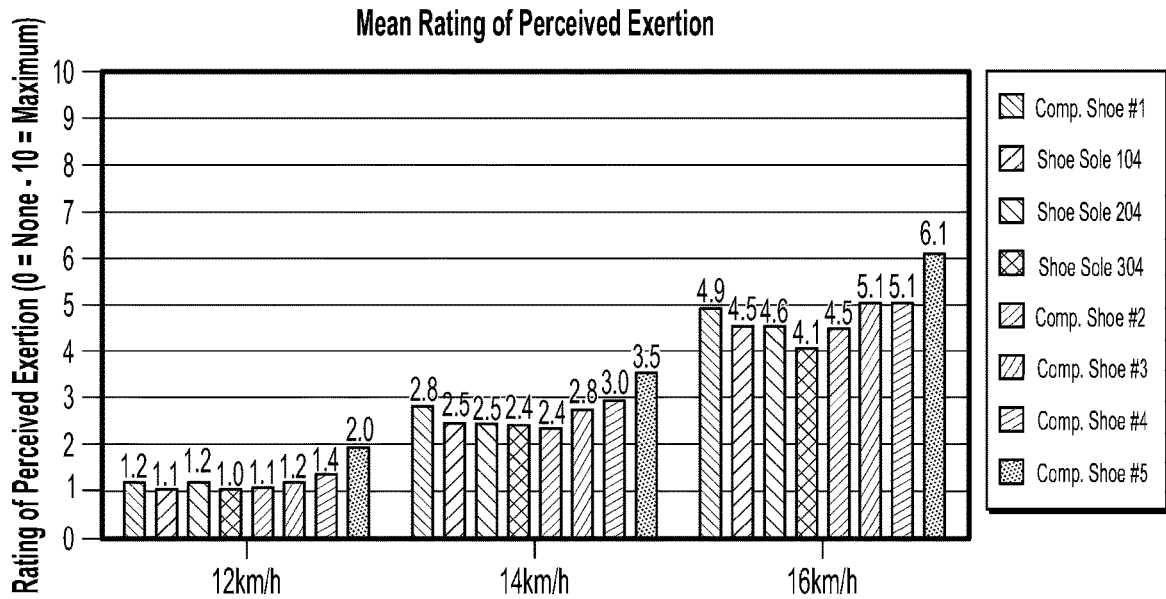

FIG. 92

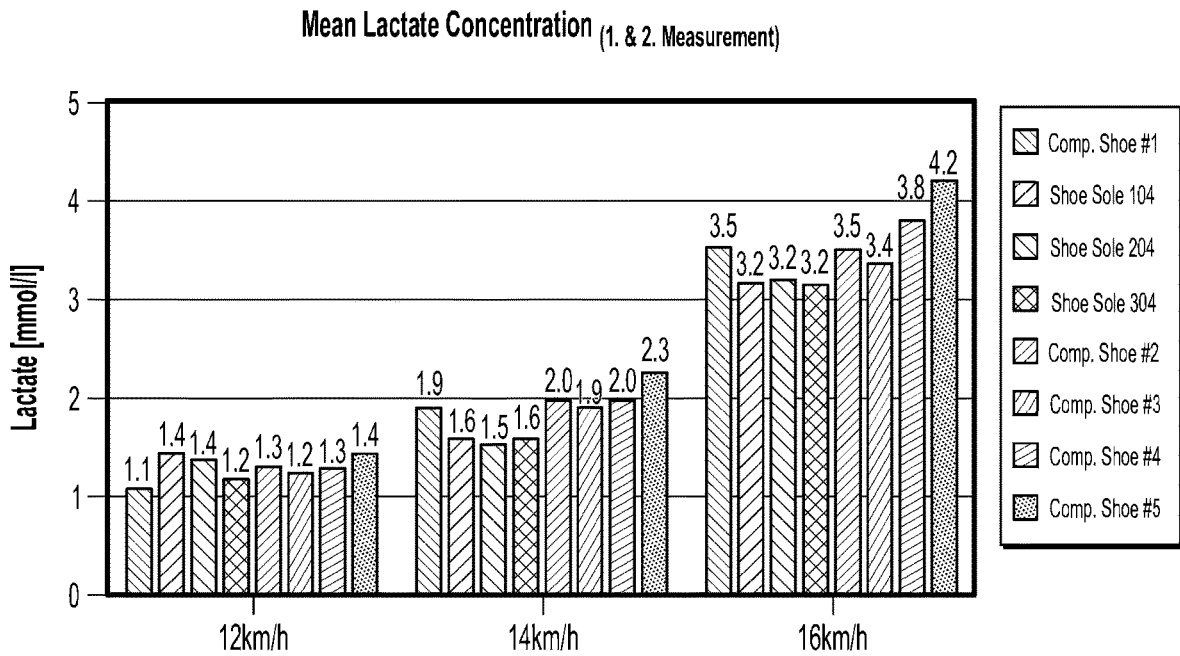

FIG. 93

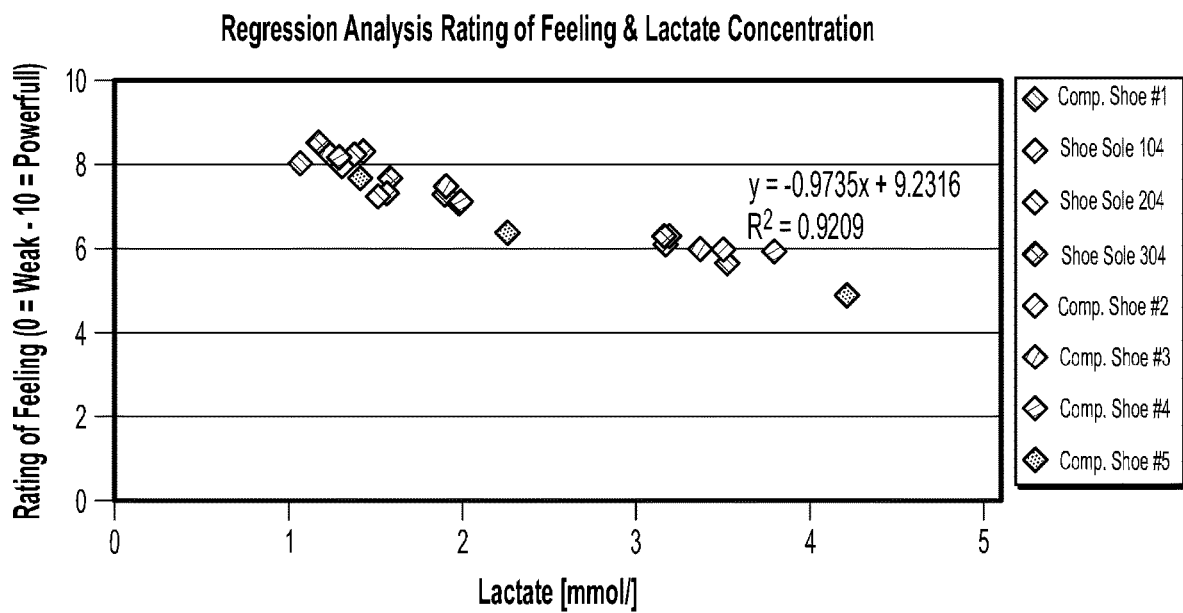

FIG. 94

US 11,825,904 B2

1

ARTICLE OF FOOTWEAR HAVING A SOLE PLATE**CROSS REFERENCE TO RELATED APPLICATIONS**

This patent application is a continuation of U.S. patent application Ser. No. 17/404,388, filed Aug. 17, 2021, which claims the benefit of U.S. Provisional Patent Application 63/067,073, filed on Aug. 18, 2020, the entire contents of which is hereby incorporated by reference, for any and all purposes.

REFERENCE REGARDING FEDERALLY SPONSORED RESEARCH OR DEVELOPMENT

Not applicable

SEQUENCE LISTING

Not applicable

BACKGROUND**1. Field of the Invention**

The present disclosure relates generally to an article of footwear including a sole plate.

2. Description of the Background

Many conventional shoes or other articles of footwear generally comprise an upper and a sole attached to a lower end of the upper. Conventional shoes further include an internal space, i.e., a void or cavity, which is created by interior surfaces of the upper and sole, that receives a foot of a user before securing the shoe to the foot. The sole attaches to a lower surface or boundary of the upper and positions itself between the upper and the ground. As a result, the sole typically provides stability and cushioning to the user when the shoe is being worn. In some instances, the sole may include multiple components, such as an outsole, a midsole, and an insole. The outsole may provide traction to a bottom surface of the sole, and the midsole may be attached to an inner surface of the outsole, and may provide cushioning or added stability to the sole. For example, a sole may include a particular foam material that may increase stability at one or more desired locations along the sole, or a foam material that may reduce stress or impact energy on the foot or leg when a user is running, walking, or engaged in another activity. The sole may also include additional components, such as plates, embedded with the sole to increase the overall stiffness of the sole and reduce energy loss during use.

The upper generally extends upward from the sole and defines an interior cavity that completely or partially encases a foot. In most cases, the upper extends over the instep and toe regions of the foot, and across medial and lateral sides thereof. Many articles of footwear may also include a tongue that extends across the instep region to bridge a gap between edges of medial and lateral sides of the upper, which define an opening into the cavity. The tongue may also be disposed below a lacing system and between medial and lateral sides of the upper, to allow for adjustment of shoe tightness. The tongue may further be manipulable by a user to permit entry or exit of a foot from the internal space or cavity. In addition, the lacing system may allow a user to adjust certain dimen-

2

sions of the upper or the sole, thereby allowing the upper to accommodate a wide variety of foot types having varying sizes and shapes.

The upper of many shoes may comprise a wide variety of materials, which may be utilized to form the upper and chosen for use based on one or more intended uses of the shoe. The upper may also include portions comprising varying materials specific to a particular area of the upper. For example, added stability may be desirable at a front of the upper or adjacent a heel region so as to provide a higher degree of resistance or rigidity. In contrast, other portions of a shoe may include a soft woven textile to provide an area with stretch-resistance, flexibility, air-permeability, or moisture-wicking properties.

However, in many cases, articles of footwear having uppers with an increased comfort and better fit are desired, along with soles having improved cushioning systems or structural characteristics such as a sole plate to add rigidity or spring-like properties.

SUMMARY

An article of footwear, as described herein, may have various configurations. The article of footwear may have an upper and a sole structure connected to the upper.

According to one aspect of the disclosure, a sole structure for an article of footwear having an upper can include a first cushioning member disposed in a heel region of the sole structure and a second cushioning member disposed in a forefoot region of the sole structure. The second cushioning member can be and spaced apart from the first cushioning member by a gap that can extend between the first cushioning member and the second cushioning member. A sole plate can extend across the gap between the first cushioning member and the second cushioning member.

In some embodiments, the sole plate can include a rear portion and a curved portion. The curved portion can include an anterior curved portion disposed proximate the second cushioning member and a posterior portion that can span the gap between the first cushioning member and the second cushioning member. The rear portion can be disposed within the heel region and can include a planar portion. In some cases, the curved portion can be coupled to the second cushioning member and the rear portion can be coupled to at least one of the first cushioning member and the upper. The second cushioning member can be positioned between the sole plate and the upper.

In some embodiments, the first cushioning member can include a longitudinal groove within the heel region. The longitudinal groove can segment the first cushioning member into a first flex zone and a second flex zone. In some cases, the sole structure can further include an outsole. The outsole can include a first outsole portion secured to the first flex zone and a second outsole portion secured to the second flex zone.

In some embodiments, the sole structure can include an outsole defining a ground engaging surface, which can be discontinuous in a midfoot region. In some cases, the first cushioning member can be positioned between the sole plate and the outsole in the heel region, and/or the second cushioning member can be positioned between the sole plate and the outsole in the forefoot region. The sole plate can be positioned between the first cushioning member and the upper, and/or the second cushioning member can be positioned between the sole plate and the upper.

In some embodiments, the first cushioning member can extend from the heel region into a midfoot region and the

US 11,825,904 B2

3

second cushioning member can extend from the forefoot region into the midfoot region. A front end of the first cushioning member can extend from the heel region toward and past a rear end of the second cushioning member in the midfoot region such that the front end of the first cushioning member can be closer to the forefoot region than can be the rear end of the second cushioning member. The front end of the first cushioning member can be positioned above the rear end of the second cushioning member.

In some embodiments, the at least one of the first cushioning member and the second cushioning member can be a supercritical foam with pockets of gas therein. The sole plate can extend through the gap between the first cushioning member and the second cushioning member.

According to another aspect of the disclosure, a sole structure for an article of footwear having an upper can include a first cushioning member and a second cushioning member. The second cushioning member can be spaced apart from the first cushioning member by a gap that can extend between the first cushioning member and the second cushioning member. A sole plate can extend across the gap from the first cushioning member to the second cushioning member, the sole plate extending away from the upper moving across the gap from the first cushioning member to the second cushioning member.

In some embodiments, the first cushioning member can be positioned in a heel region of the sole structure and the second cushioning member can be positioned in a forefoot region of the sole structure. The sole plate can be positioned between the first cushioning member and the upper, and/or the second cushioning member can be positioned between the sole plate and the upper.

In some embodiments, the sole plate can include a substantially planar rear portion coupled to the first cushioning member, an anterior curved portion coupled to the second cushioning member, and a posterior curved portion that spans the gap between the first cushioning member and the second cushioning member. The gap can extend along a non-linear path that can extend from a medial side of the sole structure to a lateral side of the sole structure.

In some embodiments, the sole plate can be positioned within at least one of the first cushioning member and the second cushioning member. In some cases, the sole plate can be coupled to the first cushioning member.

According to yet another aspect of the disclosure, an article of footwear can include an upper and a sole structure that can extend between the upper and a ground surface. The sole structure can define a ground engaging surface and can include an outsole and a sole plate. The sole plate can be positioned between the upper and the outsole and can include a rear portion in a heel region, an anterior curved portion in a forefoot region, and a posterior curved portion extending away from the upper between the rear portion and the anterior curved portion.

In some embodiments, the article of footwear can further include a first cushioning member and a second cushioning member. The first cushioning member and the second cushioning member can be spaced apart from one another by a gap that can extend between the first cushioning member and the second cushioning member from a lateral side to a medial side. The first cushioning member can be positioned between the sole plate and the outsole, and the second cushioning member can be positioned between the sole plate and the upper. Each of the first cushioning member and the second cushioning member can be positioned between the sole plate and the outsole.

4

In some cases, the rear portion of the sole plate can be configured as a substantially planar portion and can be secured to at least one of the upper and the first cushioning member. The first cushioning member can define a U-shaped end and the sole plate can extend into the U-shaped end. In some cases, the sole plate can bifurcate at least one of the first cushioning member and the second cushioning member.

In some embodiments, the anterior curved portion of the sole plate can extend along the ground engaging surface.

According to still another aspect of the disclosure, a sole structure for an article of footwear having an upper can include a first cushioning member disposed in a heel region of the sole structure and a second cushioning member disposed in a forefoot region of the sole structure. The second cushioning member can be spaced apart from the first cushioning member in a midsole region of the sole structure by a gap that can extend between the first cushioning member and the second cushioning member from a lateral side of the sole structure to a medial side of the sole structure. The sole structure can further include a sole plate that can include a rear portion in the heel region, an anterior curved portion in the forefoot region, and a posterior curved portion extending between the rear portion and the anterior curved portion. The sole plate can extend away from the upper as the sole plate extends between the first cushioning member and the second cushioning member.

Other aspects of the article of footwear, including features and advantages thereof, will become apparent to one of ordinary skill in the art upon examination of the figures and detailed description herein. Therefore, all such aspects of the article of footwear are intended to be included in the detailed description and this summary.

BRIEF DESCRIPTION OF THE DRAWINGS

FIG. 1 is a lateral side view of an article of footwear configured as a left shoe that includes an upper and a sole structure, according to an embodiment of the disclosure;

FIG. 2 is a top, lateral side view of the sole structure of the article of footwear of FIG. 1, the sole structure having a sole plate;

FIG. 3 is a lateral side view of the sole structure of FIG. 2;

FIG. 4 is a bottom view of the sole structure of FIG. 2; FIG. 5 is a medial side view of the sole structure of FIG. 2;

FIG. 6 is a cross-sectional view of the sole structure of FIG. 4 taken along line 6-6 thereof;

FIG. 7 is a top view of the sole structure of FIG. 2;

FIG. 8 is a cross-sectional view of the sole structure of FIG. 4 taken along line 8-8 thereof;

FIG. 9 is a cross-sectional view of the sole structure of FIG. 4 taken along line 9-9 thereof;

FIG. 10 is a cross-sectional view of the sole structure of FIG. 4 taken along line 10-10 thereof;

FIG. 11 is a cross-sectional view of the sole structure of FIG. 4 taken along line 11-11 thereof;

FIG. 12 is a cross-sectional view of the sole structure of FIG. 4 taken along line 12-12 thereof;

FIG. 13 is an isometric view of the sole plate of the sole structure of FIG. 2;

FIG. 14 is a lateral side view of an article of footwear configured as a left shoe that includes an upper and a sole structure, according to another embodiment of the disclosure;

US 11,825,904 B2

5

FIG. 15 is a top, lateral side view of the sole structure of the article of footwear of FIG. 14, the sole structure having a sole plate;

FIG. 16 is a lateral side view of the sole structure of FIG. 15;

FIG. 17 is a bottom view of the sole structure of FIG. 15;

FIG. 18 is a medial side view of the sole structure of FIG. 15;

FIG. 19 is a cross-sectional view of the sole structure of FIG. 17 taken along line 19-19 thereof;

FIG. 20 is a top view of the sole structure of FIG. 15;

FIG. 21 is a cross-sectional view of the sole structure of FIG. 17 taken along line 21-21 thereof;

FIG. 22 is a cross-sectional view of the sole structure of FIG. 17 taken along line 22-22 thereof;

FIG. 23 is a cross-sectional view of the sole structure of FIG. 17 taken along line 23-23 thereof;

FIG. 24 is a cross-sectional view of the sole structure of FIG. 17 taken along line 24-24 thereof;

FIG. 25 is a cross-sectional view of the sole structure of FIG. 17 taken along line 25-25 thereof;

FIG. 26 is an isometric view of the sole plate of the sole structure of FIG. 15;

FIG. 27 is a side view of the sole plate of FIG. 26;

FIG. 28 is a top view of the sole plate of FIG. 26;

FIG. 29 is a lateral side view of an article of footwear configured as a left shoe that includes an upper and a sole structure, according to yet another embodiment of the disclosure;

FIG. 30 is a top, lateral side view of the sole structure of the article of footwear of FIG. 29, the sole structure having a sole plate;

FIG. 31 is a lateral side view of the sole structure of FIG. 30;

FIG. 32 is a bottom view of the sole structure of FIG. 30;

FIG. 33 is a medial side view of the sole structure of FIG. 30;

FIG. 34 is a cross-sectional view of the sole structure of FIG. 32 taken along line 34-34 thereof;

FIG. 35 is a top view of the sole structure of FIG. 30;

FIG. 36 is a cross-sectional view of the sole structure of FIG. 32 taken along line 36-36 thereof;

FIG. 37 is a cross-sectional view of the sole structure of FIG. 32 taken along line 37-37 thereof;

FIG. 38 is a cross-sectional view of the sole structure of FIG. 32 taken along line 38-38 thereof;

FIG. 39 is a cross-sectional view of the sole structure of FIG. 32 taken along line 39-39 thereof;

FIG. 40 is a cross-sectional view of the sole structure of FIG. 32 taken along line 40-40 thereof;

FIG. 41 is an isometric view of the sole plate of the sole structure of FIG. 30;

FIG. 42 is a side view of the sole plate of FIG. 41;

FIG. 43 is a top view of the sole plate of FIG. 41;

FIG. 44 is a lateral side view of an article of footwear configured as a left shoe that includes an upper and a sole structure, according to another embodiment of the disclosure;

FIG. 45 is a top, lateral side view of the sole structure of the article of footwear of FIG. 44, the sole structure having a sole plate;

FIG. 46 is a lateral side view of the sole structure of FIG. 45;

FIG. 47 is a bottom view of the sole structure of FIG. 45;

FIG. 48 is a medial side view of the sole structure of FIG. 45;

6

FIG. 49 is a cross-sectional view of the sole structure of FIG. 47 taken along line 49-49 thereof;

FIG. 50 is a top view of the sole structure of FIG. 45;

FIG. 51 is a cross-sectional view of the sole structure of FIG. 47 taken along line 51-51 thereof;

FIG. 52 is a cross-sectional view of the sole structure of FIG. 47 taken along line 52-52 thereof;

FIG. 53 is a cross-sectional view of the sole structure of FIG. 47 taken along line 53-53 thereof;

FIG. 54 is a cross-sectional view of the sole structure of FIG. 47 taken along line 54-54 thereof;

FIG. 55 is a cross-sectional view of the sole structure of FIG. 47 taken along line 55-55 thereof;

FIG. 56 is a lateral side view of an article of footwear configured as a left shoe that includes a sole structure, according to yet another embodiment of the disclosure;

FIG. 57 is a bottom view of the sole structure of FIG. 56;

FIG. 58 is a medial side view of the sole structure of FIG. 56;

FIG. 59 is a cross-sectional view of the sole structure of FIG. 57 taken along line 59-59 thereof;

FIG. 60 is a top view of the sole structure of FIG. 56;

FIG. 61 is a cross-sectional view of the sole structure of FIG. 57 taken along line 61-61 thereof;

FIG. 62 is a cross-sectional view of the sole structure of FIG. 57 taken along line 62-62 thereof;

FIG. 63 is a cross-sectional view of the sole structure of FIG. 57 taken along line 63-63 thereof;

FIG. 64 is a cross-sectional view of the sole structure of FIG. 57 taken along line 64-64 thereof;

FIG. 65 is a cross-sectional view of the sole structure of FIG. 56 taken along line 65-65 thereof;

FIG. 66 is a lateral side view of an article of footwear configured as a left shoe that includes a sole structure, according to another embodiment of the disclosure;

FIG. 67 is a bottom view of the sole structure of FIG. 66;

FIG. 68 is a medial side view of the sole structure of FIG. 66;

FIG. 69 is a cross-sectional view of the sole structure of FIG. 67 taken along line 69-69 thereof;

FIG. 70 is a top view of the sole structure of FIG. 66;

FIG. 71 is a cross-sectional view of the sole structure of FIG. 67 taken along line 71-71 thereof;

FIG. 72 is a cross-sectional view of the sole structure of FIG. 67 taken along line 72-72 thereof;

FIG. 73 is a cross-sectional view of the sole structure of FIG. 67 taken along line 72-72 thereof;

FIG. 74 is a cross-sectional view of the sole structure of FIG. 67 taken along line 72-72 thereof;

FIG. 75 is a cross-sectional view of the sole structure of FIG. 67 taken along line 72-72 thereof;

FIG. 76 is a lateral side view of an article of footwear configured as a left shoe that includes a sole structure, according to yet another embodiment of the disclosure;

FIG. 77 is a bottom view of the sole structure of FIG. 76;

FIG. 78 is a medial side view of the sole structure of FIG. 76;

FIG. 79 is a cross-sectional view of the sole structure of FIG. 77 taken along line 79-79 thereof;

FIG. 80 is a top view of the sole structure of FIG. 76;

FIG. 81 is a cross-sectional view of the sole structure of FIG. 77 taken along line 81-81 thereof;

FIG. 82 is a cross-sectional view of the sole structure of FIG. 77 taken along line 81-81 thereof;

FIG. 83 is a cross-sectional view of the sole structure of FIG. 77 taken along line 82-82 thereof;

US 11,825,904 B2

7

FIG. **84** is a cross-sectional view of the sole structure of FIG. **77** taken along line **83-83** thereof;

FIG. **85** is a cross-sectional view of the sole structure of FIG. **77** taken along line **84-84** thereof;

FIG. **86** is an isometric view of the sole plate for use with the sole structures of FIG. **56**, **66**, or **76**;

FIG. **87** is a top plan view of the sole plate of FIG. **86**;

FIG. **88** is an isometric view of another plate for use with the sole structures of FIGS. **66** and **76**;

FIG. **89** is a top plan view of the plate of FIG. **88**;

FIG. **90** schematically depicts a mean relative maximum oxygen uptake relative to a velocity of a runner, according to one or more aspects described herein;

FIG. **91** schematically depicts a mean heart rate relative to velocity of a runner, according to the aspects described herein;

FIG. **92** schematically depicts a mean rating of perceived exertion relative to a velocity of a runner, according to the aspects described herein;

FIG. **93** schematically depicts a mean lactate concentration relative to a velocity of a runner, according to the aspects described herein; and

FIG. **94** schematically depicts a regression analysis comparing a rate of feeling to a lactate concentration, according to the aspects described herein.

DETAILED DESCRIPTION OF THE DRAWINGS

The following discussion and accompanying figures disclose various embodiments or configurations of a shoe and a sole structure. Although embodiments of a shoe or sole structure are disclosed with reference to a sports shoe, such as a running shoe, tennis shoe, basketball shoe, etc., concepts associated with embodiments of the shoe or the sole structure may be applied to a wide range of footwear and footwear styles, including cross-training shoes, football shoes, golf shoes, hiking shoes, hiking boots, ski and snowboard boots, soccer shoes and cleats, walking shoes, and track cleats, for example. Concepts of the shoe or the sole structure may also be applied to articles of footwear that are considered non-athletic, including dress shoes, sandals, loafers, slippers, and heels. In addition to footwear, particular concepts described herein may also be applied and incorporated in other types of apparel or other athletic equipment, including helmets, padding or protective pads, shin guards, and gloves. Even further, particular concepts described herein may be incorporated in cushions, backpack straps, golf clubs, or other consumer or industrial products. Accordingly, concepts described herein may be utilized in a variety of products.

The term “about,” as used herein, refers to variation in the numerical quantity that may occur, for example, through typical measuring and manufacturing procedures used for articles of footwear or other articles of manufacture that may include embodiments of the disclosure herein; through inadvertent error in these procedures; through differences in the manufacture, source, or purity of the ingredients used to make the compositions or mixtures or carry out the methods; and the like. Throughout the disclosure, the terms “about” and “approximately” refer to a range of values $\pm 5\%$ of the numeric value that the term precedes.

The terms “weight percent,” “wt-%,” “percent by weight,” “% by weight,” and variations thereof, as used herein, refer to the concentration of a substance or component as the weight of that substance or component divided by the total weight, for example, of the composition or of a particular component of the composition, and multiplied by

8

100. It is understood that, as used herein, “percent,” “%,” and the like may be synonymous with “weight percent” and “wt-%.”

The present disclosure is directed to an article of footwear and/or specific components of the article of footwear, such as an upper and/or a sole or sole structure. The upper may comprise a knitted component, a woven textile, and/or a non-woven textile. The knitted component may be made by knitting of yarn, the woven textile by weaving of yarn, and the non-woven textile by manufacture of a unitary non-woven web. Knitted textiles include textiles formed by way of warp knitting, weft knitting, flat knitting, circular knitting, and/or other suitable knitting operations. The knit textile may have a plain knit structure, a mesh knit structure, and/or a rib knit structure, for example. Woven textiles include, but are not limited to, textiles formed by way of any of the numerous weave forms, such as plain weave, twill weave, satin weave, dobbin weave, jacquard weave, double weaves, and/or double cloth weaves, for example. Non-woven textiles include textiles made by air-laid and/or spun-laid methods, for example. The upper may comprise a variety of materials, such as a first yarn, a second yarn, and/or a third yarn, which may have varying properties or varying visual characteristics.

FIGS. **1-12** depict an exemplary embodiment of an article of footwear **100** including an upper **102** and a sole structure **104**. The upper **102** is attached to the sole structure **104** and together define an interior cavity into which a foot may be inserted. For reference, the article of footwear **100** defines a forefoot region **108**, a midfoot region **110**, and a heel region **112**. The forefoot region **108** generally corresponds with portions of the article of footwear **100** that encase portions of the foot that includes the toes, the ball of the foot, and joints connecting the metatarsals with the toes or phalanges. The midfoot region **110** is proximate and adjoining the forefoot region **108**, and generally corresponds with portions of the article of footwear **100** that encase the arch of foot, along with the bridge of the foot. The heel region **112** is proximate and adjoining the midfoot region **110** and generally corresponds with portions of the article of footwear **100** that encase rear portions of the foot, including the heel or calcaneus bone, the ankle, and/or the Achilles tendon.

Many conventional footwear uppers are formed from multiple elements (e.g., textiles, polymer foam, polymer sheets, leather, and synthetic leather) that are joined through bonding or stitching at a seam. In some embodiments, the upper **102** of the article of footwear **100** is formed from a knitted structure or knitted components. In various embodiments, a knitted component may incorporate various types of yarn that may provide different properties to an upper. For example, one area of the upper **102** may be formed from a first type of yarn that imparts a first set of properties, and another area of the upper **102** may be formed from a second type of yarn that imparts a second set of properties. Using this configuration, properties of the upper **102** may vary throughout the upper **102** by selecting specific yarns for different areas of the upper **102**.

The article of footwear **100** also includes a medial side **116** (e.g., see FIG. **3**) and a lateral side **118** (e.g., see FIG. **5**). In particular, the lateral side **118** corresponds to an outside portion of the article of footwear **100** and the medial side **116** corresponds to an inside portion of the article of footwear **100**. As such, left and right articles of footwear have opposing lateral and medial sides, such that the medial sides **116** are closest to one another when a user is wearing the articles of footwear **100**, while the lateral sides **118** are defined as the sides that are farthest from one another while

being worn. The medial side **116** and the lateral side **118** adjoin one another at opposing, distal ends of the article of footwear **100**.

Unless otherwise specified, the forefoot region **108**, the midfoot region **110**, the heel region **112**, the medial side **116**, and the lateral side **118** are intended to define boundaries or areas of the article of footwear **100**. To that end, the forefoot region **108**, the midfoot region **110**, the heel region **112**, the medial side **116**, and the lateral side **118** generally characterize sections of the article of footwear **100**. Further, both the upper **102** and the sole structure **104** may be characterized as having portions within the forefoot region **108**, the midfoot region **110**, the heel region **112**, and on the medial side **116** and the lateral side **118**. Therefore, the upper **102** and the sole structure **104**, and/or individual portions of the upper **102** and the sole structure **104**, may include portions thereof that are disposed within the forefoot region **108**, the midfoot region **110**, the heel region **112**, and on the medial side **116** and the lateral side **118**.

The sole structure **104** is connected or secured to the upper **102** and extends between a foot of a user and the ground when the article of footwear **100** is worn by the user. The sole structure **104** may include one or more components, which may include an outsole, a midsole, a heel, a vamp, and/or an insole. For example, in some embodiments, a sole structure may include an outsole that provides structural integrity to the sole structure, along with providing traction for a user, a midsole that provides a cushioning system, and an insole that provides support for an arch of a user. As will be further discussed herein, the sole structure **104** of the present embodiment of the invention includes one or more components that provide the sole structure **104** with preferable spring and damping properties.

The sole structure **104** includes an outsole **130**, a first cushioning member **132**, a second cushioning member **134**, and a sole plate **136** (see FIG. 6). The outsole **130** may define a bottom end or surface of the sole structure **104** across the heel region **112**, the midfoot region **110**, and the forefoot region **108**. Further, the outsole **130** may be a ground-engaging portion or include a ground-engaging surface of the sole structure **104** and may be opposite of the insole thereof. The outsole **130** may be formed from one or more materials to impart durability, wear-resistance, abrasion resistance, or traction to the sole structure **104**. In some embodiments, the outsole **130** may be formed from rubber, for example.

The first cushioning member **132** may be positioned adjacent to and on top of the outsole **130** in the heel region **112**, and positioned adjacent to and on top of the second cushioning member **134** in the midfoot region **110** and forefoot region **108**. The first cushioning member **132** may include one or more longitudinal grooves or flex lines **138** that extend between the medial side **116** and the lateral side **118**, which segments the first cushioning member **132** in the heel region **112**. For example, in the particular embodiment shown in FIGS. 1-12, the first cushioning member **132** includes five flex lines **138**, which define four flex regions **140**. Further, as best shown in FIG. 4, the flex lines **138** may have a sinusoidal shape between the medial side **116** and the lateral side **118**.

The second cushioning member **134** may be positioned adjacent to and on top of the outsole **130** in the midfoot region **110** and forefoot region **108**. As will be further discussed herein, the second cushioning member **134** may also be positioned between or be enclosed within the sole plate **136** in the midfoot region **110** and/or the forefoot region **108** (see FIG. 6).

The first cushioning member **132** and/or the second cushioning member **134** may be individually constructed from a thermoplastic material, such as polyurethane (PU), for example, and/or an ethylene-vinyl acetate (EVA), copolymers thereof, or a similar type of material. In other embodiments, the first cushioning member **132** and/or the second cushioning member **134** may be an EVA-Solid-Sponge ("ESS") material, an EVA foam (e.g., PUMA® ProFoam Lite™, IGNITE Foam), polyurethane, polyether, an olefin block copolymer, a thermoplastic material (e.g., a thermoplastic polyurethane, a thermoplastic elastomer, a thermoplastic polyolefin, etc.), or a supercritical foam. The first cushioning member **132** and/or the second cushioning member **134** may be a single polymeric material or may be a blend of materials, such as an EVA copolymer, a thermoplastic polyurethane, a polyether block amide (PEBA) copolymer, and/or an olefin block copolymer. One example of a PEBA material is PEBAX®.

In embodiments where the first cushioning member **132** and/or the second cushioning member **134** is formed from a supercritical foaming process, the supercritical foam may comprise micropore foams or particle foams, such as a TPU, EVA, PEBAX®, or mixtures thereof, manufactured using a process that is performed within an autoclave, an injection molding apparatus, or any sufficiently heated/pressurized container that can process the mixing of a supercritical fluid (e.g., CO₂, N₂, or mixtures thereof) with a material (e.g., TPU, EVA, polyolefin elastomer, or mixtures thereof) that is preferably molten. During an exemplary process, a solution of supercritical fluid and molten material is pumped into a pressurized container, after which the pressure within the container is released, such that the molecules of the supercritical fluid rapidly convert to gas to form small pockets within the material and cause the material to expand into a foam, which may be used as the first cushioning member **132** and, more preferably, the second cushioning member **134**. In further embodiments, the first cushioning member **132** and/or the second cushioning member **134** may be formed using alternative methods known in the art, including the use of an expansion press, an injection machine, a pellet expansion process, a cold foaming process, a compression molding technique, die cutting, or any combination thereof. For example, the first cushioning member **132** and/or the second cushioning member **134** may be formed using a process that involves an initial foaming step in which supercritical gas is used to foam a material and then compression molded or die cut to a particular shape.

The sole structure **104** further includes the sole plate **136**, which as best shown in FIG. 13, includes an upper flange **150** and a lower flange **152** and an arched, curved, or C-shaped rear portion **154** that connects the upper flange **150** and the lower flange **152**. Further, a gap **156** extends between the upper flange **150** and the lower flange **152**, into which the second cushioning member **134** may be positioned, as previously discussed herein. As shown in FIG. 6, the sole plate **136** extends at least partially through the midfoot region **110** and at least partially through the forefoot region **108**. As further illustrated in FIG. 6, the rear portion **154** of the sole plate **136** may be spaced from a rear side of the second cushioning member **134**, which creates a spacing **158** therebetween.

With continued reference to FIG. 6, the lower flange **152** may be adjacent to and positioned between the outsole **130** and the second cushioning member **134**, and the upper flange **150** may be adjacent to and positioned between the second cushioning member **134** and the first cushioning member **132**. In some embodiments, the sole plate **136** has

US 11,825,904 B2

11

a uniform thickness. For example, in particular embodiments, the thickness is approximately 1.2 centimeters.

In some embodiments, the sole plate **136** comprises a PU plastic, such as a thermoplastic polyurethane (TPU) material, for example. Other thermoplastic elastomers consisting of block copolymers are also possible. In other embodiments, the sole plate **136** can include carbon fiber, for example.

In some embodiments, the outsole **130** or the ground-engaging surface is not continuous along the article of footwear **100**. For example, as best shown in FIG. **6**, there is a spacing **158**, or an absence of a ground-engaging surface, along the article of footwear **100**, which is located within the midfoot region **110** of the article of footwear **100**.

FIGS. **14-25** show another configuration of an article of footwear **200**. Similar to the sole structure **104**, the sole structure **204** is configured to be attached to an upper **202** and together define an interior cavity into which a foot may be inserted. For reference, the sole structure **204** defines a forefoot region **208**, a midfoot region **210**, and a heel region **212**. The forefoot region **208** generally corresponds with portions of an article of footwear, such as the article of footwear **200**, for example, that encase portions of the foot that include the toes, the ball of the foot, and joints connecting the metatarsals with the toes or phalanges. The midfoot region **210** is proximate and adjoining the forefoot region **208**, and generally corresponds with portions of the article of footwear that encase the arch of a foot, along with the bridge of a foot. The heel region **212** is proximate and adjoining the midfoot region **210** and generally corresponds with portions of the article of footwear that encase rear portions of the foot, including the heel or calcaneus bone, the ankle, and/or the Achilles tendon.

The article of footwear **200** also includes a medial side **216** (e.g., see FIG. **18**) and a lateral side **218** (e.g., see FIG. **16**). In particular, the lateral side **218** corresponds to an outside portion of the article of footwear **200** and the medial side **216** corresponds to an inside portion of the article of footwear **200**. As such, left and right articles of footwear have opposing lateral and medial sides, such that the medial sides **216** are closest to one another when a user is wearing the articles of footwear **200**, while the lateral sides **218** are defined as the sides that are farthest from one another while being worn. The medial side **216** and the lateral side **218** adjoin one another at opposing, distal ends of the article of footwear **200**.

Unless otherwise specified, the forefoot region **208**, the midfoot region **210**, the heel region **212**, the medial side **216**, and the lateral side **218** are intended to define boundaries or areas of the article of footwear **200**. To that end, the forefoot region **208**, the midfoot region **210**, the heel region **212**, the medial side **216**, and the lateral side **218** generally characterize sections of the article of footwear **200**. Further, both the upper **202** and the sole structure **204** may be characterized as having portions within the forefoot region **208**, the midfoot region **210**, the heel region **212**, and on the medial side **216** and the lateral side **218**. Therefore, the upper **202** and the sole structure **204**, may include portions thereof that are disposed within the forefoot region **208**, the midfoot region **210**, the heel region **212**, and on the medial side **216** and the lateral side **218**.

The sole structure **204** is connected or secured to the upper **202** and extends between a foot of a user and the ground when the article of footwear **200** is worn by the user. The sole structure **204** may include one or more components, which may include an outsole, a midsole, a heel, a

12

vamp, and/or an insole. For example, in some embodiments, a sole structure may include an outsole that provides structural integrity to the sole structure, along with providing traction for a user, a midsole that provides a cushioning system, and an insole that provides support for an arch of a user. As will be further discussed herein, the sole structure **204** of the present embodiment of the invention includes one or more components that provide the sole structure **204** with preferable spring and damping properties.

The sole structure **204** includes an outsole **230**, a first cushioning member **232**, a second cushioning member **234**, and a sole plate **236** (see FIG. **19**). The outsole **230** may define a bottom end or surface of the sole structure **204** across the heel region **212**, the midfoot region **210**, and the forefoot region **208**. Further, the outsole **230** may be a ground-engaging portion or include a ground-engaging surface of the sole structure **204** and may be opposite of the insole thereof. The outsole **230** may be formed from one or more materials to impart durability, wear-resistance, abrasion resistance, or traction to the sole structure **204**. In some embodiments, the outsole **230** may be formed from rubber, for example.

The first cushioning member **232** may be positioned adjacent to and on top of the outsole **230** in the heel region **212**, and positioned adjacent to and on top of the second cushioning member **234** in the midfoot region **210** and forefoot region **208**. The first cushioning member **232** may include one or more longitudinal grooves or flex lines **238** that extend between the medial side **216** and the lateral side **218**, which segments the first cushioning member **232** in the heel region **212**. For example, in the particular embodiment shown in FIGS. **14-25**, the first cushioning member **232** includes five flex lines **238**, which define four flex regions **240**. Further, as best shown in FIG. **17**, the flex lines **238** may have a sinusoidal shape between the medial side **216** and the lateral side **218**.

The second cushioning member **234** may be positioned adjacent to and on top of the outsole **230** in the midfoot region **210** and forefoot region **208**. As will be further discussed herein, the second cushioning member **234** may also be positioned between or be enclosed within the sole plate **236** in the forefoot region **208** (see FIG. **19**).

The first cushioning member **232** and/or the second cushioning member **234** may be individually constructed from a thermoplastic material, such as polyurethane (PU), for example, and/or an ethylene-vinyl acetate (EVA), copolymers thereof, or a similar type of material. In other embodiments, the first cushioning member **232** and/or the second cushioning member **234** may be an EVA-Solid-Sponge ("ESS") material, an EVA foam (e.g., PUMA® ProFoam Lite™, IGNITE Foam), polyurethane, polyether, an olefin block copolymer, a thermoplastic material (e.g., a thermoplastic polyurethane, a thermoplastic elastomer, a thermoplastic polyolefin, etc.), or a supercritical foam. The first cushioning member **232** and/or the second cushioning member **234** may be a single polymeric material or may be a blend of materials, such as an EVA copolymer, a thermoplastic polyurethane, a polyether block amide (PEBA) copolymer, and/or an olefin block copolymer. One example of a PEBA material is PEBAX®.

In embodiments where the first cushioning member **232** and/or the second cushioning member **234** is formed from a supercritical foaming process, the supercritical foam may comprise micropore foams or particle foams, such as a TPU, EVA, PEBAX®, or mixtures thereof, manufactured using a process that is performed within an autoclave, an injection molding apparatus, or any sufficiently heated/pressurized

container that can process the mixing of a supercritical fluid (e.g., CO₂, N₂, or mixtures thereof) with a material (e.g., TPU, EVA, polyolefin elastomer, or mixtures thereof) that is preferably molten. During an exemplary process, a solution of supercritical fluid and molten material is pumped into a pressurized container, after which the pressure within the container is released, such that the molecules of the supercritical fluid rapidly convert to gas to form small pockets within the material and cause the material to expand into a foam, which may be used as the first cushioning member **232** and, more preferably, the second cushioning member **234**. In further embodiments, the first cushioning member **232** and/or the second cushioning member **234** may be formed using alternative methods known in the art, including the use of an expansion press, an injection machine, a pellet expansion process, a cold foaming process, a compression molding technique, die cutting, or any combination thereof. For example, the first cushioning member **232** and/or the second cushioning member **234** may be formed using a process that involves an initial foaming step in which supercritical gas is used to foam a material and then compression molded or die cut to a particular shape.

The sole structure **204** further includes the sole plate **236**, which is best shown in FIGS. **26-28**, includes an upper flange **250** and a lower flange **252** that connect at a vertex point **254**. Further, a gap **256** extends between the upper flange **250** and the lower flange **252**, into which the second cushioning member **234** may be positioned, as previously discussed herein. As shown in FIG. **19**, the sole plate **236** extends through the forefoot region **208**. As further illustrated in FIG. **19**, the vertex point **254** may be spaced from a front side of the second cushioning member **234**, which creates a spacing or gap **258** between the upper flange **250** and the lower flange **252**.

With continued reference to FIG. **19**, a rear portion of the lower flange **252** may be adjacent to and positioned between the outsole **230** and the second cushioning member **234**, and a rear portion of the upper flange **250** may be adjacent to and positioned between the second cushioning member **234** and the first cushioning member **232**. In some embodiments, the sole plate **236** has a uniform thickness. For example, in particular embodiments, the thickness is approximately 1.2 centimeters.

With reference to FIGS. **26** and **28**, the upper flange **250** and the lower flange **252** may also include one or more cut-out portions **260**, **262**. The cut-out portions **260**, **262** may be advantageous to allow the medial and lateral sides of the sole plate **236** to flex independent of one another.

In some embodiments, the sole plate **236** comprises a PU plastic, such as a thermoplastic polyurethane (TPU) material, for example. Other thermoplastic elastomers consisting of block copolymers are also possible. In other embodiments, the sole plate **236** can include carbon fiber, for example.

In some embodiments, the outsole **230** or the ground-engaging surface is not continuous along the article of footwear **200**. For example, as best shown in FIG. **19**, there is a spacing **264**, or an absence of a ground-engaging surface, along the article of footwear **200**, which is located within the midfoot region **210** of the article of footwear **200**.

FIGS. **29-40** show another configuration of an article of footwear **300**. Similar to the sole structures **104**, **204**, the sole structure **304** is configured to be attached to an upper **302** and together define an interior cavity into which a foot may be inserted. For reference, the sole structure **304** defines a forefoot region **308**, a midfoot region **310**, and a heel region **312**. The forefoot region **308** generally corresponds

with portions of an article of footwear, such as the article of footwear **300**, for example, that encase portions of the foot that include the toes, the ball of the foot, and joints connecting the metatarsals with the toes or phalanges. The midfoot region **310** is proximate and adjoining the forefoot region **308**, and generally corresponds with portions of the article of footwear that encase the arch of a foot, along with the bridge of a foot. The heel region **312** is proximate and adjoining the midfoot region **310** and generally corresponds with portions of the article of footwear that encase rear portions of the foot, including the heel or calcaneus bone, the ankle, and/or the Achilles tendon.

The article of footwear **300** also includes a medial side **316** (e.g., see FIG. **33**) and a lateral side **318** (e.g., see FIG. **31**). In particular, the lateral side **318** corresponds to an outside portion of the article of footwear **300** and the medial side **316** corresponds to an inside portion of the article of footwear **300**. As such, left and right articles of footwear have opposing lateral and medial sides, such that the medial sides **316** are closest to one another when a user is wearing the articles of footwear **300**, while the lateral sides **318** are defined as the sides that are farthest from one another while being worn. The medial side **316** and the lateral side **318** adjoin one another at opposing, distal ends of the article of footwear **300**.

Unless otherwise specified, the forefoot region **308**, the midfoot region **310**, the heel region **312**, the medial side **316**, and the lateral side **318** are intended to define boundaries or areas of the article of footwear **300**. To that end, the forefoot region **308**, the midfoot region **310**, the heel region **312**, the medial side **316**, and the lateral side **318** generally characterize sections of the article of footwear **300**. Further, both the upper **302** and the sole structure **304** may be characterized as having portions within the forefoot region **308**, the midfoot region **310**, the heel region **312**, and on the medial side **316** and the lateral side **318**. Therefore, the upper **302** and the sole structure **304**, and/or individual portions of the upper **302** and the sole structure **304**, may include portions thereof that are disposed within the forefoot region **308**, the midfoot region **310**, the heel region **312**, and on the medial side **316** and the lateral side **318**.

The sole structure **304** is connected or secured to the upper **302** and extends between a foot of a user and the ground when the article of footwear **300** is worn by the user. The sole structure **304** may include one or more components, which may include an outsole, a midsole, a heel, a vamp, and/or an insole. For example, in some embodiments, a sole structure may include an outsole that provides structural integrity to the sole structure, along with providing traction for a user, a midsole that provides a cushioning system, and an insole that provides support for an arch of a user. As will be further discussed herein, the sole structure **304** of the present embodiment of the invention includes one or more components that provide the sole structure **304** with preferable spring and damping properties.

The sole structure **304** includes an outsole **330**, a first cushioning member **332**, a second cushioning member **334**, and a sole plate **336** (see FIG. **34**). The outsole **330** may define a bottom end or surface of the sole structure **304** across the heel region **312**, the midfoot region **310**, and the forefoot region **308**. Further, the outsole **330** may be a ground-engaging portion or include a ground-engaging surface of the sole structure **304** and may be opposite of the insole thereof. The outsole **330** may be formed from one or more materials to impart durability, wear-resistance, abra-

sion resistance, or traction to the sole structure **304**. In some embodiments, the outsole **330** may be formed from rubber, for example.

The first cushioning member **332** may be positioned adjacent to and on top of the outsole **330** in the heel region **312**. The first cushioning member **332** may also be positioned adjacent to and below the sole plate **336**. The first cushioning member **332** may include one or more longitudinal grooves or flex lines **338** that extend between the medial side **316** and the lateral side **318**, which segments the first cushioning member **332** in the heel region **312**. For example, in the particular embodiment shown in FIGS. **29-40**, the first cushioning member **332** includes five flex lines **338**, which define four flex regions **340**. Further, as best shown in FIG. **32**, the flex lines **338** may have a sinusoidal shape between the medial side **316** and the lateral side **318**.

The second cushioning member **334** may be positioned adjacent to and on top of the outsole **330** in the midfoot region **310** and forefoot region **308**. As will be further discussed herein, the sole plate **336** may also bifurcate the second cushioning member **334**, such that the sole plate **336** is positioned within the second cushioning member **334** (see FIG. **34**).

The first cushioning member **332** and/or the second cushioning member **334** may be individually constructed from a thermoplastic material, such as polyurethane (PU), for example, and/or an ethylene-vinyl acetate (EVA), copolymers thereof, or a similar type of material. In other embodiments, the first cushioning member **332** and/or the second cushioning member **334** may be an EVA-Solid-Sponge (“ESS”) material, an EVA foam (e.g., PUMA® ProFoam Lite™, IGNITE Foam), polyurethane, polyether, an olefin block copolymer, a thermoplastic material (e.g., a thermoplastic polyurethane, a thermoplastic elastomer, a thermoplastic polyolefin, etc.), or a supercritical foam. The first cushioning member **332** and/or the second cushioning member **334** may be a single polymeric material or may be a blend of materials, such as an EVA copolymer, a thermoplastic polyurethane, a polyether block amide (PEBA) copolymer, and/or an olefin block copolymer. One example of a PEBA material is PEBAX®.

In embodiments where the first cushioning member **332** and/or the second cushioning member **334** is formed from a supercritical foaming process, the supercritical foam may comprise micropore foams or particle foams, such as a TPU, EVA, PEBAX®, or mixtures thereof, manufactured using a process that is performed within an autoclave, an injection molding apparatus, or any sufficiently heated/pressurized container that can process the mixing of a supercritical fluid (e.g., CO₂, N₂, or mixtures thereof) with a material (e.g., TPU, EVA, polyolefin elastomer, or mixtures thereof) that is preferably molten. During an exemplary process, a solution of supercritical fluid and molten material is pumped into a pressurized container, after which the pressure within the container is released, such that the molecules of the supercritical fluid rapidly convert to gas to form small pockets within the material and cause the material to expand into a foam, which may be used as the first cushioning member **332** and, more preferably, the second cushioning member **334**. In further embodiments, the first cushioning member **332** and/or the second cushioning member **334** may be formed using alternative methods known in the art, including the use of an expansion press, an injection machine, a pellet expansion process, a cold foaming process, a compression molding technique, die cutting, or any combination thereof. For example, the first cushioning member **332** and/or the second cushioning member **334** may be formed

using a process that involves an initial foaming step in which supercritical gas is used to foam a material and then compression molded or die cut to a particular shape.

The sole structure **304** further includes the sole plate **336**, which as best shown in FIGS. **41-43**, includes a curved portion **350** and a rear portion **352**, which may be relatively planar. The curved portion **350** may also include an anterior curved portion **354** and a posterior curved portion **356**. The anterior curved portion **354** and the posterior curved portion **356** may each individually include one or more radii of curvature.

With reference to FIG. **34**, the curved portion **350** of the plate **336** may be positioned within the second cushioning member **334** and the rear portion **352** of the plate **336** may be positioned above the first cushioning member **332**. Further, a portion of the posterior curved portion **356** may extend between a gap **358** between the first cushioning member **332** and the second cushioning member **334**. Resultantly, in this embodiment, a portion of the plate **336** does not include a cushioning member—such as the first cushioning member **332** or the second cushioning member **334**—above, below, or between the plate **336**. Thus, the plate **336** is spaced from the upper **302** and a gap, or absence of material, is present between the plate **336** and the upper **302** approximate the midfoot region **310** and/or the heel region **312** (see FIG. **29**). In some embodiments, the sole plate **336** has a uniform thickness. For example, in particular embodiments, the thickness is approximately 1.2 centimeters.

In some embodiments, the sole plate **336** comprises a PU plastic, such as a thermoplastic polyurethane (TPU) material, for example. Other thermoplastic elastomers consisting of block copolymers are also possible. In other embodiments, the sole plate **336** can include carbon fiber, for example.

As briefly noted herein, in some embodiments, the outsole **330** or the ground-engaging surface is not continuous along the article of footwear **300**. For example, as best shown in FIG. **34**, there is a spacing or gap **358**, or an absence of a ground-engaging surface, along the article of footwear **300**, which is located within the midfoot region **310** of the article of footwear **300**.

FIGS. **44-55** show another configuration of an article of footwear **400**. Similar to the sole structures **104**, **204**, **304**, the sole structure **404** is configured to be attached to an upper **402** and together define an interior cavity into which a foot may be inserted. Like the other sole structures, the sole structure **404** can be defined by a forefoot region **408**, a midfoot region **410**, a heel region **412**, as well as a medial side **416** (see FIG. **48**) and a lateral side **418** (see FIG. **46**). Like the other embodiments described herein, unless otherwise specified, the forefoot region, the midfoot region, the heel region, the medial side **416**, and the lateral side **418** are intended to define boundaries or areas of the article of footwear **400**. To that end, the forefoot region, the midfoot region, the heel region, the medial side **416**, and the lateral side **418** generally characterize sections of the article of footwear **400**. Further, both the upper **402** and the sole structure **404** may be characterized as having portions within the forefoot region **408**, the midfoot region **410**, the heel region **412**, and on the medial side **416** and the lateral side **418**. Therefore, the upper **402** and the sole structure **404**, and/or individual portions of the upper **402** and the sole structure **404**, may include portions thereof that are disposed within the forefoot region **408**, the midfoot region **410**, the heel region **412**, and on the medial side **416** and the lateral side **418**.

US 11,825,904 B2

17

The sole structure **404** is connected or secured to the upper **402** and extends between a foot of a user and the ground when the article of footwear **400** is worn by the user. The sole structure **404** may include one or more components, which may include an outsole, a midsole, a heel, a vamp, and/or an insole. For example, in some embodiments, a sole structure may include an outsole that provides structural integrity to the sole structure, along with providing traction for a user, a midsole that provides a cushioning system, and an insole that provides support for an arch of a user. As will be further discussed herein, the sole structure **404** of the present embodiment of the invention includes one or more components that provide the sole structure **404** with preferable spring and damping properties.

The sole structure **404** includes an outsole **430**, a first cushioning member **432**, a second cushioning member **434**, and a sole plate **436** (see FIG. **49**). The outsole **430** may define a bottom end or surface of the sole structure **404** across the heel region **412**, the midfoot region **410**, and the forefoot region **408**. Further, the outsole **430** may be a ground-engaging portion or include a ground-engaging surface of the sole structure **404** and may be opposite of the insole thereof. The outsole **430** may be formed from one or more materials to impart durability, wear-resistance, abrasion resistance, or traction to the sole structure **404**. In some embodiments, the outsole **430** may be formed from rubber, for example.

The first cushioning member **432** may be positioned adjacent to and on top of the outsole **430** in the heel region **412**, and positioned adjacent to and on top of the second cushioning member **434** in the midfoot region **410** and forefoot region **408**. The first cushioning member **432** may include one or more longitudinal grooves or flex lines **438** that extend between the medial side **416** and the lateral side **418**, which segments the first cushioning member **432** in the heel region **412**. For example, in the particular embodiment shown in FIGS. **44-55**, the first cushioning member **432** includes five flex lines **438**, which define four flex regions **440**. Further, as best shown in FIG. **47**, the flex lines **438** may have a sinusoidal shape between the medial side **416** and the lateral side **418**.

The second cushioning member **434** may be positioned adjacent to and on top of the outsole **430** in the midfoot region **410** and forefoot region **408**. As will be further discussed herein, the second cushioning member **434** may also be positioned between or be enclosed within the sole plate **436** in the forefoot region **408** (see FIG. **49**).

The first cushioning member **432** and/or the second cushioning member **434** may be individually constructed from a thermoplastic material, such as polyurethane (PU), for example, and/or an ethylene-vinyl acetate (EVA), copolymers thereof, or a similar type of material. In other embodiments, the first cushioning member **432** and/or the second cushioning member **434** may be an EVA-Solid-Sponge ("ESS") material, an EVA foam (e.g., PUMA® ProFoam Lite™, IGNITE Foam), polyurethane, polyether, an olefin block copolymer, a thermoplastic material (e.g., a thermoplastic polyurethane, a thermoplastic elastomer, a thermoplastic polyolefin, etc.), or a supercritical foam. The first cushioning member **432** and/or the second cushioning member **434** may be a single polymeric material or may be a blend of materials, such as an EVA copolymer, a thermoplastic polyurethane, a polyether block amide (PEBA) copolymer, and/or an olefin block copolymer. One example of a PEBA material is PEBAX®.

In embodiments where the first cushioning member **432** and/or the second cushioning member **434** is formed from a

18

supercritical foaming process, the supercritical foam may comprise micropore foams or particle foams, such as a TPU, EVA, PEBAX®, or mixtures thereof, manufactured using a process that is performed within an autoclave, an injection molding apparatus, or any sufficiently heated/pressurized container that can process the mixing of a supercritical fluid (e.g., CO₂, N₂, or mixtures thereof) with a material (e.g., TPU, EVA, polyolefin elastomer, or mixtures thereof) that is preferably molten. During an exemplary process, a solution of supercritical fluid and molten material is pumped into a pressurized container, after which the pressure within the container is released, such that the molecules of the supercritical fluid rapidly convert to gas to form small pockets within the material and cause the material to expand into a foam, which may be used as the first cushioning member **432** and, more preferably, the second cushioning member **434**. In further embodiments, the first cushioning member **432** and/or the second cushioning member **434** may be formed using alternative methods known in the art, including the use of an expansion press, an injection machine, a pellet expansion process, a cold foaming process, a compression molding technique, die cutting, or any combination thereof. For example, the first cushioning member **432** and/or the second cushioning member **434** may be formed using a process that involves an initial foaming step in which supercritical gas is used to foam a material and then compression molded or die cut to a particular shape.

The sole structure **404** further includes the sole plate **436**, which as best shown in FIGS. **49** and **50**, is a relatively planar structure having a first cut-out portion **450** near a front end thereof and a second cut-out portion **452** near a rear end thereof.

With particular reference to FIG. **49**, the plate **436** may be positioned above the first cushioning member **432** in the midfoot region **410**. In some embodiments, the sole plate **436** has a uniform thickness. For example, in particular embodiments, the thickness is approximately 1.8 centimeters.

In some embodiments, the sole plate **436** comprises a PU plastic, such as a thermoplastic polyurethane (TPU) material, for example. Other thermoplastic elastomers consisting of block copolymers are also possible. In other embodiments, the sole plate **436** can include carbon fiber, for example.

As briefly noted herein, in some embodiments, the outsole **430** or the ground-engaging surface is not continuous along the article of footwear **400**. For example, as best shown in FIG. **49**, there is a spacing or gap **458**, or an absence of a ground-engaging surface, along the article of footwear **400**, which is located within the midfoot region **410** of the article of footwear **400**.

FIGS. **56-65** show another configuration of an article of footwear **500** having an upper **502** and a sole structure **504**. Similar to the sole structures **104**, **204**, **304**, **404**, the sole structure **504** is configured to be attached to the upper **502** and together define an interior cavity into which a foot may be inserted. Also similar to the other sole structures, the sole structure **504** includes a forefoot region **508**, a midfoot region **510**, a heel region **512**, a medial side **516** (see FIG. **58**) and a lateral side **518** (see FIG. **56**). Unless otherwise specified, the forefoot region **508**, the midfoot region **510**, the heel region **512**, the medial side **516**, and the lateral side **518** are intended to define boundaries or areas of the article of footwear **500**. Further, as will be further discussed herein, the sole structure **504** of the present embodiment of the

US 11,825,904 B2

19

invention includes one or more components that provide the sole structure **504** with preferable spring and damping properties.

The sole structure **504** also includes an outsole **530**, a first cushioning member **532**, a second cushioning member **534**, and a sole plate **536** (see FIG. **59**). The first cushioning member **532** may be positioned adjacent to and on top of the outsole **530** in the heel region **512**. The first cushioning member **532** may also be positioned adjacent to and below the sole plate **536**. The first cushioning member **532** may include one or more longitudinal grooves or flex lines **538** that extend between the medial side **516** and the lateral side **518**, which segments the first cushioning member **532** in the heel region **512**.

The second cushioning member **534** may be positioned adjacent to and on top of the outsole **530** in the midfoot region **510** and forefoot region **508**. As will be further discussed herein, the sole plate **536** may also extend between the second cushioning member **534** and the outsole **530** (see FIG. **59**). The first cushioning member **532** and/or the second cushioning member **534** may be individually constructed from a thermoplastic material, such as polyurethane (PU), for example, and/or an ethylene-vinyl acetate (EVA), copolymers thereof, or a similar type of material. In other embodiments, the first cushioning member **532** and/or the second cushioning member **534** may be an EVA-Solid-Sponge (“ESS”) material, an EVA foam (e.g., PUMA® ProFoam Lite™, IGNITE Foam), polyurethane, polyether, an olefin block copolymer, a thermoplastic material (e.g., a thermoplastic polyurethane, a thermoplastic elastomer, a thermoplastic polyolefin, etc.), or a supercritical foam. The first cushioning member **532** and/or the second cushioning member **534** may be a single polymeric material or may be a blend of materials, such as an EVA copolymer, a thermoplastic polyurethane, a polyether block amide (PEBA) copolymer, and/or an olefin block copolymer. One example of a PEBA material is PEBAX®.

The sole structure **504** further includes the sole plate **536**, which as best shown in FIG. **59**, includes a curved portion **550** and a rear portion **552**, which may be relatively planar. The curved portion **550** may also include an anterior curved portion **554** and a posterior curved portion **556**. The anterior curved portion **554** and the posterior curved portion **556** may each individually include one or more radii of curvature.

With reference to FIG. **59**, the curved portion **550** of the plate **536** may be positioned below the second cushioning member **534** and the rear portion **552** of the plate **536** may be positioned above the first cushioning member **532**. Further, a portion of the posterior curved portion **556** may extend between a gap **558** between the first cushioning member **532** and the second cushioning member **534**. In some embodiments, the sole plate **536** has a uniform thickness. For example, in particular embodiments, the thickness is approximately 1.2 centimeters. In some embodiments, the sole plate **536** comprises a PU plastic, such as a thermoplastic polyurethane (TPU) material, for example. Other thermoplastic elastomers consisting of block copolymers are also possible. In other embodiments, the sole plate **536** can include carbon fiber, for example.

As briefly noted herein, in some embodiments, the outsole **530** or the ground-engaging surface is not continuous along the article of footwear **500**. For example, as best shown in FIG. **59**, there is a spacing or gap **558**, or an absence of a ground-engaging surface, along the article of footwear **500**, which is located within the midfoot region **510** and/or the heel region **512** of the article of footwear **500**. In this embodiment, similar to the plate **336**, a portion of the plate

20

536 does not include a cushioning member—such as the first cushioning member **532** or the second cushioning member **534**—above, below, or between the plate **536**. Thus, the plate **536** is spaced from the upper **502** and a gap, or absence of material, is present between the plate **536** and the upper **502** approximate the midfoot region **510** and/or the heel region **512** (see FIG. **59**).

In some embodiments, the sole structure **504** may also include a second plate **560**. In the particular embodiment shown in FIGS. **56-65**, the second plate **560** encases the sole plate **536** such that the sole plate **536** sits within the second plate **560**. Additionally, as best shown in FIG. **59**, the second plate **560** extends across the forefoot region **508**, the midfoot region **510**, and the heel region **512**. Thus, the second plate **560** is positioned below the sole plate **536** across an entire length thereof. In other embodiments, as will be further discussed herein, the second plate **560** may only extend across a portion of the sole plate **536** and may be positioned at a location along the sole structure **504** where the sole plate **536** needs targeted structural support. The second plate **560** may be constructed from similar materials to the sole plate **536**, which have already been discussed herein. However, in particular embodiments, the material used to construct the second plate **560** may also differ from the material used to construct the sole plate **536** such that the second plate **560** provides added reinforcement to the sole plate **536**. For example, in one embodiment, the sole plate **536** may be constructed from a carbon fiber material and the second plate **560** may be constructed from thermoplastic polyurethane (TPU) to support the sole plate **536**. Additionally, the second plate **560** may support the structural integrity of the sole plate **536** and prevent the sole plate **536** from fracturing during use thereof.

In addition to the second plate **560**, an amount of material may be injected into one or more grooves of the sole plate **536**. More particularly, in this embodiment, the sole plate **536** may include two grooves **562** (see FIG. **63**) and a material **564** may be injected or positioned within the grooves **562**. Similar to the second plate **560**, the material injected into the grooves **562** may provide further structural support to the sole plate **536** and targeted support to the sole plate **536**. For example, in this particular embodiment, the grooves are provided across the midfoot or arch region of the sole structure **504**, and therefore, the material **564** may provide support to the sole plate **536** in the arch region thereof, which thereby provides further support to a user's foot in the arch region of the sole structure **504**. The injected material **564** may be a suitable plastic material, such as thermoplastic polyurethane (TPU) or the like.

FIGS. **66-75** show another configuration of an article of footwear **600** having an upper **602** and a sole structure **604**. Similar to the sole structures **104**, **204**, **304**, **404**, **504** the sole structure **604** is configured to be attached to the upper **602** and together define an interior cavity into which a foot may be inserted. The sole structure **604**, similar to the other sole structures, includes a forefoot region **608**, a midfoot region **610**, a heel region **612**, a medial side **616** (see FIG. **68**) and a lateral side **618** (see FIG. **66**). Unless otherwise specified, the forefoot region **608**, the midfoot region **610**, the heel region **612**, the medial side **616**, and the lateral side **618** are intended to define boundaries or areas of the article of footwear **600**.

The sole structure **604** also includes an outsole **630**, a first cushioning member **632**, a second cushioning member **634**, and a sole plate **636** (see FIG. **69**). The outsole **630** may

US 11,825,904 B2

21

define a bottom end or surface of the sole structure **604** across the heel region **612**, the midfoot region **610**, and the forefoot region **608**.

The first cushioning member **632** may be positioned adjacent to and on top of the outsole **630** in the heel region **612**. The first cushioning member **632** may also be positioned adjacent to and below the sole plate **636**. The first cushioning member **632** may include one or more longitudinal grooves or flex lines **638** that extend between the medial side **616** and the lateral side **618**, which segments the first cushioning member **632** in the heel region **612**.

The second cushioning member **634** may be positioned adjacent to and on top of the outsole **630** in the midfoot region **610** and forefoot region **608**. As will be further discussed herein, the sole plate **636** may also bifurcate the second cushioning member **634**, such that the sole plate **636** is positioned within the second cushioning member **634** (see FIG. **69**).

The first cushioning member **632** and/or the second cushioning member **634** may be individually constructed from similar materials to those already disclosed in connection with the other embodiments disclosed herein.

The sole structure **604** further includes the sole plate **636**, which as best shown in FIGS. **69**, includes a curved portion **650** and a rear portion **652**, which may be relatively planar. The curved portion **650** may also include an anterior curved portion **654** and a posterior curved portion **656**. The anterior curved portion **654** and the posterior curved portion **656** may each individually include one or more radii of curvature.

With reference to FIG. **69**, the curved portion **650** of the plate **636** may be positioned within the second cushioning member **634** and the rear portion **652** of the plate **636** may be positioned above the first cushioning member **632**. Further, a portion of the posterior curved portion **656** may extend between a gap **658** between the first cushioning member **632** and the second cushioning member **634**. In some embodiments, the sole plate **636** has a uniform thickness. For example, in particular embodiments, the thickness is approximately 1.2 centimeters.

In some embodiments, the sole plate **636** comprises a PU plastic, such as a thermoplastic polyurethane (TPU) material, for example. Other thermoplastic elastomers consisting of block copolymers are also possible. In other embodiments, the sole plate **636** can include carbon fiber, for example.

As briefly noted herein, in some embodiments, the outsole **630** or the ground-engaging surface is not continuous along the article of footwear **600**. For example, as best shown in FIG. **69**, there is a spacing or gap **658**, or an absence of a ground-engaging surface, along the article of footwear **600**, which is located within the midfoot region **610** of the article of footwear **600**.

Similar to the sole structure **504**, the sole structure **604** may also include a second plate **660**. In the particular embodiment shown in FIGS. **66-75**, the second plate **660** partially encases the sole plate **636** such that the sole plate **636** sits within the second plate **660**. Additionally, as best shown in FIG. **69**, the second plate **660** extends across the midfoot region **610** and the heel region **610**. Thus, the second plate **660** is positioned below the sole plate **636** across a portion of the sole plate **636**, and more particularly, the arch or midfoot region thereof. In other embodiments, as previously discussed herein, the second plate **660** may extend across an entire length of the sole plate **636** or may be positioned at a location along the sole structure **604** where the sole plate **636** needs targeted structural support. The second plate **660** may be constructed from similar materials

22

to the sole plate **636**, which have already been discussed herein. However, in particular embodiments, the material used to construct the second plate **660** may differ from the material used to construct the sole plate **636** such that the second plate **660** provides added reinforcement to the sole plate **636**. For example, in one embodiment, the sole plate **636** may be constructed from a carbon fiber material and the second plate **660** may be constructed from thermoplastic polyurethane (TPU) to support the sole plate **636**. Additionally, the second plate **660** may support the structural integrity of the sole plate **636** and prevent the sole plate **636** from fracturing during use thereof.

In addition to the second plate **660**, an amount of material may be injected into one or more grooves of the sole plate **636**. More particularly, in this embodiment, the sole plate **636** may include two grooves **662** (see FIG. **73**) and material **664** may be injected or positioned within the grooves **662**. Similar to the second plate **660**, the material injected into the grooves **662** may provide further structural support to the sole plate **636** and targeted support to the sole plate **636**. For example, in this particular embodiment, the grooves are provided across the midfoot or arch region of the sole structure **604**, and therefore, the material **664** may provide support to the sole plate **636** in the arch region thereof, which thereby provides further support to a user's foot in the arch region of the sole structure **604**. The injected material **664** may be a suitable plastic material, such as thermoplastic polyurethane (TPU) or the like.

FIGS. **76-85** show another configuration of an article of footwear **700** having an upper **702** and a sole structure **704**. Similar to the sole structures **104**, **204**, **304**, **404**, **504**, **604** the sole structure **704** is configured to be attached to the upper **702** and together define an interior cavity into which a foot may be inserted. Further, the sole structure **704** includes a forefoot region **708**, a midfoot region **710**, a heel region **712**, a medial side **716** (see FIG. **78**), and a lateral side **718** (see FIG. **76**). Unless otherwise specified, the forefoot region **708**, the midfoot region **710**, the heel region **712**, the medial side **716**, and the lateral side **718** are intended to define boundaries or areas of the article of footwear **700**.

The sole structure **704** includes an outsole **730**, a first cushioning member **732**, a second cushioning member **734**, and a sole plate **736** (see FIG. **79**). The outsole **730** may define a bottom end or surface of the sole structure **704** across the heel region **712**, the midfoot region **710**, and the forefoot region **708**.

The first cushioning member **732** may be positioned adjacent to and on top of the outsole **730** in the heel region **712**. The first cushioning member **732** may also be positioned adjacent to and below the sole plate **736**. The first cushioning member **732** may include one or more longitudinal grooves or flex lines **738** that extend between the medial side **716** and the lateral side **718**, which segments the first cushioning member **732** in the heel region **712**.

The second cushioning member **734** may be positioned adjacent to and on top of the outsole **730** in the midfoot region **710** and forefoot region **708**. As will be further discussed herein, the sole plate **736** may also bifurcate the second cushioning member **734**, such that the sole plate **736** is positioned within the second cushioning member **734** (see FIG. **79**). Further, the sole plate **736** may also bifurcate the first cushioning member **732**, such that the sole plate **736** is positioned within the first cushioning member as well (see FIG. **79**).

The first cushioning member **732** and/or the second cushioning member **734** may be individually constructed

US 11,825,904 B2

23

from similar materials to the first and second cushioning members of the other embodiments.

The sole structure **704** also includes the sole plate **736**, which as best shown in FIG. **79**, includes a curved portion **750** and a rear portion **752**, which may be relatively planar. The curved portion **750** may also include an anterior curved portion **754** and a posterior curved portion **756**. The anterior curved portion **754** and the posterior curved portion **756** may each individually include one or more radii of curvature.

With reference to FIG. **79**, the curved portion **750** of the plate **736** may be positioned within the second cushioning member **734** and the rear portion **752** of the plate **736** may be positioned above the first cushioning member **732**. Further, a portion of the posterior curved portion **756** may extend between a gap **758** between the first cushioning member **732** and the second cushioning member **734**. In some embodiments, the sole plate **736** has a uniform thickness. For example, in particular embodiments, the thickness is approximately 1.2 centimeters.

In some embodiments, the sole plate **736** comprises a PU plastic, such as a thermoplastic polyurethane (TPU) material, for example. Other thermoplastic elastomers consisting of block copolymers are also possible. In other embodiments, the sole plate **736** can include carbon fiber, for example.

As briefly noted herein, in some embodiments, the outsole **730** or the ground-engaging surface is not continuous along the article of footwear **700**. For example, as best shown in FIG. **79**, there is a spacing or gap **758**, or an absence of a ground-engaging surface, along the article of footwear **700**, which is located within the midfoot region **710** of the article of footwear **700**.

Similar to the sole structures **504**, **604**, the sole structure **704** may also include a second plate **760**. In the particular embodiment shown in FIGS. **76-85**, the second plate **760** partially encases the sole plate **736** such that the sole plate **736** sits within the second plate **760**. Additionally, as best shown in FIG. **79**, the second plate **760** extends across the midfoot region **710** and the heel region **712**. Thus, the second plate **760** is only positioned below the sole plate **736** across a portion of the sole plate **736**, and more particularly, the arch or midfoot region thereof. In other embodiments, as previously discussed herein, the second plate **760** may extend across an entire length of the sole plate **736** or may be positioned at a location along the sole structure **704** where the sole plate **736** needs targeted structural support. The second plate **760** may be constructed from similar materials to the sole plate **736**, which have already be discussed herein. However, in particular embodiments, the material used to construct the second plate **760** may differ from the material used to construct the sole plate **736** such that the second plate **760** provides added reinforcement to the sole plate **736**. For example, in one embodiment, the sole plate **736** may be constructed from a carbon fiber material and the second plate **760** may be constructed from thermoplastic polyurethane (TPU) to support the sole plate **736**. Additionally, the second plate **760** may support the structural integrity of the sole plate **736** and prevent the sole plate **736** from fracturing during use thereof.

In addition to the second plate **760**, an amount of material may be injected into one or more grooves of the sole plate **736**. More particularly, in this embodiment, the sole plate **736** may include two grooves **762** formed from a plurality of raised portions **764** (see FIGS. **83**, **86**, and **87**), and material **766** may be injected or positioned within the grooves **762**. Similar to the second plate **760**, the material injected into the grooves **762** may provide further structural support to the

24

sole plate **736** and targeted support to the sole plate **736**. For example, in this particular embodiment, the grooves are provided across the midfoot or arch region of the sole structure **704**, and therefore, the material **766** may provide support to the sole plate **736** in the arch region thereof, which thereby provides further support to a user's foot in the arch region of the sole structure **704**. The injected material **766** may be a suitable plastic material, such as thermoplastic polyurethane (TPU) or the like.

FIGS. **88** and **89** depict the second plate **760** of the present embodiment. Further, as discussed herein in connection with several embodiments, the second plates **560**, **660**, **760** may encase the sole plates **536**, **636**, **736**. To perform this function, the second plate **560**, **660**, **760** may include outer walls or sidewalls **570**, **670**, **770** that extend upward from the main body of the second plate **560**, **660**, **760**. Additionally, the second plate **560**, **660**, **760** may include a shape that conforms to the shape of the sole plate **536**, **636**, **736**. For example, as best shown in FIGS. **88** and **89**, the second plate **760** may include a plurality of raised portions **772** and grooves **774** that conform with the plurality of raised portions **764** and grooves **762** of the sole plate **736**.

EXAMPLES

The examples herein are intended to illustrate certain embodiments of the articles of footwear and sole structures discussed herein to one of ordinary skill in the art and should not be interpreted as limiting in the scope of the disclosure set forth in the claims. The articles of footwear and sole structures of the present disclosure may comprise the following non-limiting examples.

Example 1

Several studies were conducted to assess the performance of the sole structures discussed herein in comparison to other comparative sole structures. First, a mean relative maximum oxygen uptake for a subject wearing the sole structures **104**, **204**, **304** was measured and compared to the mean relative maximum oxygen uptake of the subject wearing comparative sole structures. These measurements were performed while the subject was running on a treadmill at various speeds, including 12 km/h, 14 km/h, and 16 km/h. The results of this study are shown in FIG. **90**.

Oxygen uptake or consumption is a measure of a person's ability to take in oxygen and deliver it to the working tissues of an athlete's body, but a lower mean relative maximum oxygen uptake equates to more efficient running. In other words, if a runner is more efficient by way of a more efficient and effective shoe sole, for example, the runner needs a lower amount of oxygen, and therefore, the runner would exhibit a lower mean relative maximum oxygen uptake. With reference to FIG. **90**, the sole structure **304** consistently had the lowest mean relative maximum oxygen uptake compared to other comparative soles across all speeds. However, at the higher speed of 16 km/h, the difference between the oxygen uptake values were accentuated and the article of footwear utilizing the sole structure **304** exhibited a mean relative maximum oxygen uptake of 49.1 ml/min/kg, which was far less than the other shoes having values greater than 51 ml/min/kg. The other sole structures **104**, **204** also exhibited very low oxygen uptake values in comparison to several of the comparative shoes. These results exhibit the improved efficiency the sole structures **104**, **204**, **304** can provide to a runner or athlete.

US 11,825,904 B2

25

Example 2

Next, a mean heartrate of a subject wearing a shoe having the sole structures **104**, **204**, **304** was measured and compared to the heartrate of the subject wearing comparative sole structures. These measurements were performed while the subject was running on a treadmill at various speeds, including 12 km/h, 14 km/h, and 16 km/h.

The heartrate of a subject, like oxygen uptake, can be a measure of the efficiency of a runner and the efficiency of a sole structure worn by a runner. For example, if a runner is more efficient by way of a more efficient and effective sole structure, for example, the runner would have a lower mean heartrate. With reference to FIG. **91**, a runner wearing each sole structure **104**, **204**, **304** had a lower heartrate compared to several comparative shoe soles, which exhibits the improved efficiency imparted on a runner wearing a shoe having the sole structures **104**, **204**, **304**.

Example 3

The perceived exertion of the subjects was also documented after a subject ran on a treadmill at several speeds, including 12 km/h, 14 km/h, and 16 km/h. More particularly, a subject was asked to run at a speed of 12 km/h, for example, and then asked to provide a rating of perceived exertion from a zero to ten scale with zero indicating no perceived level of exertion and ten indicating a very high level of perceived exertion by the subject. These values were documented for articles of footwear having the sole structures **104**, **204**, **304**, compared with several comparative shoe soles, and then graphed. The results of this experiment are shown in FIG. **92**, and as shown in FIG. **92**, runners or subjects consistently provided low ratings for articles of footwear having the sole structures **104**, **204**, **304**. In particular, subjects consistently provided the lowest mean rating of perceived exertion for the sole structure **304** compared to the other sole structures, which shows the beneficial experience subjects or runners have with the sole structure **304** during use thereof.

Example 4

The mean lactate concentration for a subject wearing the sole structures **104**, **204**, **304** was also measured and compared to the lactate concentration of a subject or runner wearing articles of footwear with comparable sole structures. These measurements were performed while the subject was running on a treadmill at various speeds, including 12 km/h, 14 km/h, and 16 km/h. The results of this study are shown in FIG. **93**.

Blood lactate levels can serve as an indirect marker for biochemical events, such as fatigue within exercising muscle. Further, the concentration of blood lactate is usually 1-2 mmol/L at rest, but can rise to greater than 20 mmol/L during intense exertion. In short, the higher lactate concentration within the blood is an indication of fatigue for a runner. Therefore, lower lactate concentrations are desired because lower lactate concentrations indicate more efficient running and a more efficient sole structure that provides a higher level of performance to a runner. With reference to FIG. **93**, each sole structure **104**, **204**, **304** performed exceptionally compared to other sole structures and provided low lactate concentrations compared to the other tested sole structures. As previously discussed herein, higher speeds (such as 16 km/h) can provide clearer data and more accentuated differences between the sole structures, and

26

looking to the data collected at a running speed of 16 km/h, the sole structures **104**, **204**, **304** each registered lactate concentrations of about 3.2 mmol/l, which were significantly lower than the other comparable sole structures. As should be understood by one of ordinary skill in the art, these differences in lactate concentration (or decrease in lactate formation) can have a drastic and positive impact on runners during training, recovery, and performance activities, especially athletes or runners in endurance sports (e.g., marathon runners).

Example 5

In addition to measuring a lactate concentration of a subject or runner, a regression analysis rating of feeling and lactate concentration was performed. More particularly, for each sole structure, the subject or runner provided a perceived level of exhaustion using a zero to ten scale, with zero indicating no perceived level of exhaustion and ten indicating a very high level of exhaustion. Then these values were graphed with the lactate concentrations collected from Example 4 previously discussed herein. Specifically, for each speed and for each sole structure, the perceived levels of exhaustion for a runner were placed on a y-axis and their lactate concentrations were placed on the x-axis. This graph is shown in FIG. **94** and a regression analysis was performed to determine the statistical link between blood lactate concentration levels and perceived levels of exhaustion. After performing the regression analysis, the graph of FIG. **94** had an R-squared value of 0.92, thereby showing a strong statistical link between how tired runners felt and their lactate concentration in their blood.

Any of the embodiments described herein may be modified to include any of the structures or methodologies disclosed in connection with different embodiments. Further, the present disclosure is not limited to articles of footwear of the type specifically shown. Still further, aspects of the articles of footwear of any of the embodiments disclosed herein may be modified to work with any type of footwear, apparel, or other athletic equipment.

As noted previously, it will be appreciated by those skilled in the art that while the invention has been described above in connection with particular embodiments and examples, the invention is not necessarily so limited, and that numerous other embodiments, examples, uses, modifications and departures from the embodiments, examples and uses are intended to be encompassed by the claims attached hereto. The entire disclosure of each patent and publication cited herein is incorporated by reference, as if each such patent or publication were individually incorporated by reference herein. Various features and advantages of the invention are set forth in the following claims.

INDUSTRIAL APPLICABILITY

Numerous modifications to the present invention will be apparent to those skilled in the art in view of the foregoing description. Accordingly, this description is to be construed as illustrative only and is presented for the purpose of enabling those skilled in the art to make and use the invention. The exclusive rights to all modifications which come within the scope of the appended claims are reserved.

We claim:

1. A sole structure for an article of footwear having an upper, the sole structure comprising:
 - a first cushioning member disposed in a heel region of the sole structure;

US 11,825,904 B2

27

a second cushioning member disposed in a forefoot region of the sole structure and spaced apart from the first cushioning member by a gap that extends between the first cushioning member and the second cushioning member; and

a sole plate that extends across the gap between the first cushioning member and the second cushioning member,

wherein at least one of:

- the sole plate is positioned between the first cushioning member and the upper; and
- the second cushioning member is positioned between the sole plate and the upper.

2. The sole structure of claim 1, wherein the sole plate includes a rear portion and a curved portion, the curved portion including:

- an anterior curved portion disposed proximate the second cushioning member, and
- a posterior portion that spans the gap between the first cushioning member and the second cushioning member.

3. The sole structure of claim 2, wherein the rear portion is disposed within the heel region and includes a planar portion.

4. The sole structure of claim 2, wherein the curved portion is coupled to the second cushioning member and the rear portion is coupled to at least one of the first cushioning member and the upper.

5. The sole structure of claim 1, wherein, in the heel region, the first cushioning member includes a longitudinal groove that segments the first cushioning member into a first flex zone and a second flex zone.

6. The sole structure of claim 5 further comprising an outsole that includes a first outsole portion secured to the first flex zone and a second outsole portion secured to the second flex zone.

7. The sole structure of claim 1 further comprising an outsole defining a ground engaging surface that is discontinuous in a midfoot region, wherein at least one of:

- the first cushioning member is positioned between the sole plate and the outsole in the heel region, and
- the second cushioning member is positioned between the sole plate and the outsole in the forefoot region.

8. The sole structure of claim 1, wherein the first cushioning member extends from the heel region into a midfoot region and the second cushioning member extends from the forefoot region into the midfoot region.

9. The sole structure of claim 8, wherein a front end of the first cushioning member extends from the heel region toward and past a rear end of the second cushioning member in the midfoot region such that the front end of the first cushioning member is closer to the forefoot region than is the rear end of the second cushioning member.

10. The sole structure of claim 9, wherein the front end of the first cushioning member is positioned above the rear end of the second cushioning member.

11. The sole structure of claim 1, wherein at least one of the first cushioning member and the second cushioning member is a supercritical foam with pockets of gas therein, and

wherein the sole plate extends through the gap between the first cushioning member and the second cushioning member.

12. The sole structure of claim 1, wherein at least one of: the sole plate is positioned within at least one of the first cushioning member and the second cushioning member; and

28

the sole plate extends along a ground engaging surface in the forefoot region.

13. The sole structure of claim 1, wherein the gap extends an entire width of the sole structure from a lateral side to a medial side thereof.

14. A sole structure for an article of footwear having an upper, the sole structure comprising:

- a first cushioning member;
- a second cushioning member that is spaced apart from the first cushioning member by a gap that extends between the first cushioning member and the second cushioning member; and
- a sole plate that extends across the gap from the first cushioning member to the second cushioning member, the sole plate extending away from the upper moving across the gap from the first cushioning member to the second cushioning member,

wherein the sole plate is positioned within at least one of the first cushioning member and the second cushioning member.

15. The sole structure of claim 14, wherein the first cushioning member is positioned in a heel region of the sole structure and the second cushioning member is positioned in a forefoot region of the sole structure.

16. The sole structure of claim 14, wherein at least one of: the sole plate is positioned between the first cushioning member and the upper, and the second cushioning member is positioned between the sole plate and the upper.

17. The sole structure of claim 14, wherein the sole plate includes:

- a substantially planar rear portion coupled to the first cushioning member;
- an anterior curved portion coupled to the second cushioning member; and
- a posterior curved portion that spans the gap between the first cushioning member and the second cushioning member.

18. The sole structure of claim 14, wherein the sole plate is coupled to the first cushioning member.

19. The sole structure of claim 14, wherein the gap extends along a non-linear path that extends from a medial side of the sole structure to a lateral side of the sole structure.

20. The sole structure of claim 14, wherein at least one of: the sole plate is positioned between the first cushioning member and the upper; the second cushioning member is positioned between the sole plate and the upper; and the sole plate extends along a ground engaging surface and the second cushioning member.

21. The sole structure of claim 14, wherein the gap extends an entire width of the sole structure from a lateral side to a medial side thereof.

22. An article of footwear, comprising:

- an upper; and
- a sole structure that extends between the upper and a ground surface, the sole structure defining a ground engaging surface and including:
 - an outsole, and
 - a sole plate positioned between the upper and the outsole, the sole plate including a rear portion in a heel region, an anterior curved portion extending along the ground engaging surface in a forefoot region, and a posterior curved portion extending away from the upper between the rear portion and the anterior curved portion.

23. The article of footwear of claim 20 further comprising a first cushioning member and a second cushioning member.

US 11,825,904 B2

29

24. The article of footwear of claim 23, wherein the first cushioning member and the second cushioning member are spaced apart from one another by a gap that extends an entire width of the sole structure between the first cushioning member and the second cushioning member from a lateral side to a medial side.

25. The article of footwear of claim 21, wherein the first cushioning member is positioned between the sole plate and the outsole and the second cushioning member is positioned between the sole plate and the upper.

26. The article of footwear of claim 23, wherein the rear portion is configured as a substantially planar portion and is secured to at least one of the upper and the first cushioning member.

27. The article of footwear of claim 23, wherein the first cushioning member defines a U-shaped end and the sole plate extends into the U-shaped end.

28. The article of footwear of claim 23, wherein each of the first cushioning member and the second cushioning member are positioned between the sole plate and the outsole.

29. The article of footwear of claim 23, wherein the sole plate bifurcates at least one of the first cushioning member and the second cushioning member.

30. The article of footwear of claim 23, wherein at least one of:

the sole plate is positioned between the first cushioning member and the upper;

the second cushioning member is positioned between the sole plate and the upper; and

the sole plate is positioned within at least one of the first cushioning member and the second cushioning member.

31. The article of footwear of claim 23, wherein a front end of the first cushioning member is closer to a forefoot region than is a rear end of the second cushioning member, and

30

wherein the front end of the first cushioning member is positioned above the rear end of the second cushioning member.

32. A sole structure for an article of footwear having an upper, the sole structure comprising:

a first cushioning member disposed in a heel region of the sole structure;

a second cushioning member disposed in a forefoot region of the sole structure, the second cushioning member being spaced apart from the first cushioning member in a midfoot region of the sole structure by a gap that extends between the first cushioning member and the second cushioning member from a lateral side of the sole structure to a medial side of the sole structure; and

a sole plate including a rear portion in the heel region, an anterior curved portion extending along a ground engaging surface in the forefoot region, and a posterior curved portion extending between the rear portion and the anterior curved portion, the sole plate extending away from the upper as the sole plate extends between the first cushioning member and the second cushioning member,

wherein at least one of:

the sole plate is positioned within at least one of the first cushioning member and the second cushioning member;

the sole plate is positioned between the first cushioning member and the upper; and

the second cushioning member is positioned between the sole plate and the upper.

33. The sole structure of claim 32, wherein the gap extends an entire width of the sole structure from the lateral side to the medial side thereof.

* * * * *

EXHIBIT B



US011974629B2

(12) **United States Patent**
Redon et al.

(10) **Patent No.:** **US 11,974,629 B2**
(45) **Date of Patent:** ***May 7, 2024**

(54) **ARTICLE OF FOOTWEAR HAVING A SOLE PLATE**

(58) **Field of Classification Search**
None

See application file for complete search history.

(71) Applicant: **PUMA SE**, Herzogenaurach (DE)

(56) **References Cited**

(72) Inventors: **Arnaud Redon**, Nuremberg (DE);
Romain Girard, Lauf an der Pegnitz (DE)

U.S. PATENT DOCUMENTS

(73) Assignee: **PUMA SE**, Herzogenaurach (DE)

(*) Notice: Subject to any disclaimer, the term of this patent is extended or adjusted under 35 U.S.C. 154(b) by 0 days.

This patent is subject to a terminal disclaimer.

4,542,598	A *	9/1985	Misevich	A43B 13/16
					36/31
6,625,905	B2 *	9/2003	Kita	A43B 13/12
					36/28
6,634,121	B2 *	10/2003	Sordi	A43B 13/141
					36/31
8,418,379	B2 *	4/2013	Nishiwaki	A43B 13/181
					36/28
8,850,721	B2 *	10/2014	Long	A43B 7/22
					36/107
10,226,099	B2 *	3/2019	Bischoff	B29D 35/122
11,089,834	B2 *	8/2021	Chambers	A43B 3/0057
2002/0078591	A1 *	6/2002	Morrone	A43B 5/12
					36/102
2013/0059939	A1 *	3/2013	Sato	C08K 7/14
					26/41
2018/0132564	A1 *	5/2018	Bruce	A43B 13/189
2019/0276650	A1 *	9/2019	Baghdadi	A43B 13/186
2020/0114634	A1 *	4/2020	Hensley	A43B 13/20

(21) Appl. No.: **17/992,397**

(22) Filed: **Nov. 22, 2022**

(65) **Prior Publication Data**

US 2023/0078289 A1 Mar. 16, 2023

Related U.S. Application Data

(63) Continuation of application No. 17/404,388, filed on Aug. 17, 2021, now Pat. No. 11,622,602.

(60) Provisional application No. 63/067,073, filed on Aug. 18, 2020.

(51) **Int. Cl.**
A43B 13/18 (2006.01)
A43B 13/04 (2006.01)
A43B 13/14 (2006.01)

(52) **U.S. Cl.**
CPC **A43B 13/186** (2013.01); **A43B 13/04** (2013.01); **A43B 13/141** (2013.01); **A43B 13/146** (2013.01)

* cited by examiner

Primary Examiner — Jila M Mohandesi

(74) *Attorney, Agent, or Firm* — Quarles & Brady LLP

(57) **ABSTRACT**

An article of footwear having a sole structure and an upper, the sole structure including a first cushioning member positioned in a heel region of the sole structure and a second cushioning member positioned in a forefoot region of the sole structure. A gap extends between the first cushioning member and the second cushioning member in a midfoot region of the sole structure, and one or both of the first cushioning member or the second cushioning member are a supercritical foam with pockets of nitrogen gas therein.

26 Claims, 41 Drawing Sheets

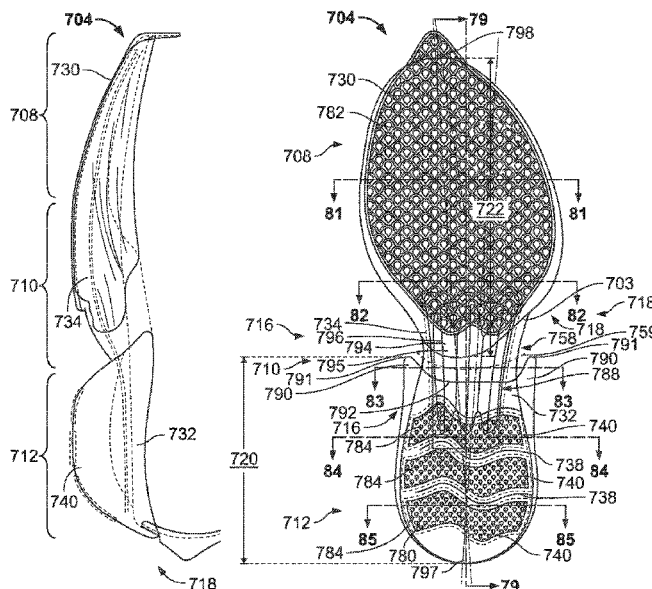

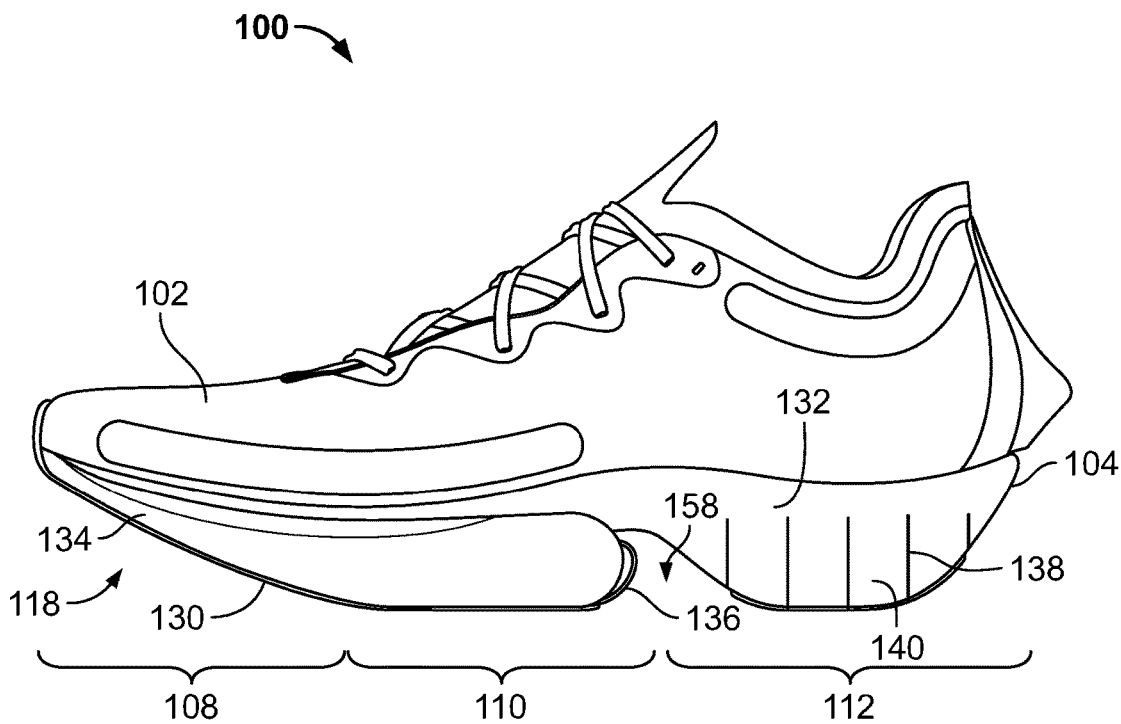

FIG. 1

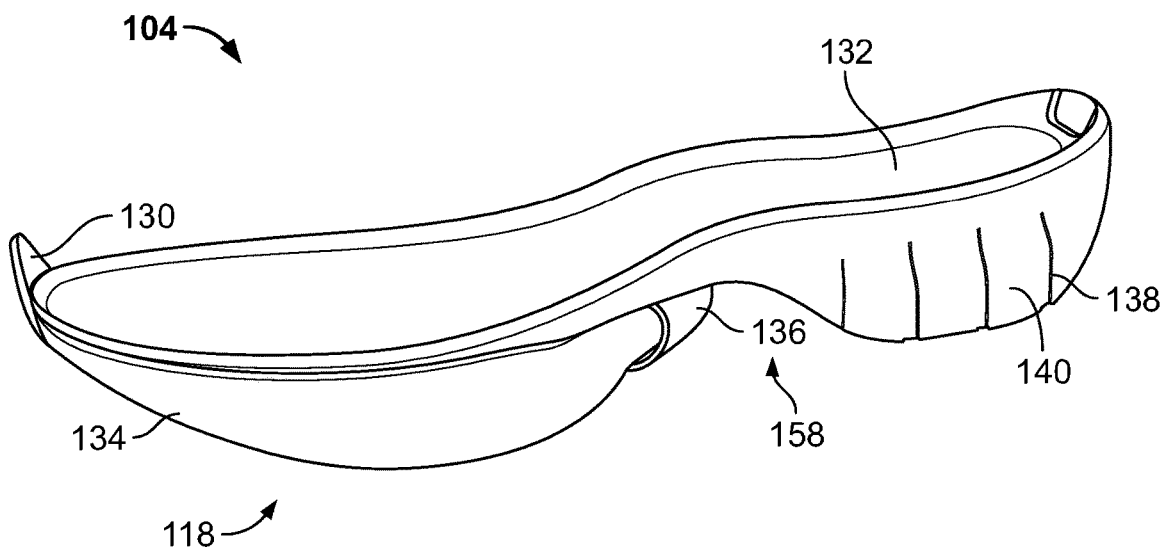

FIG. 2

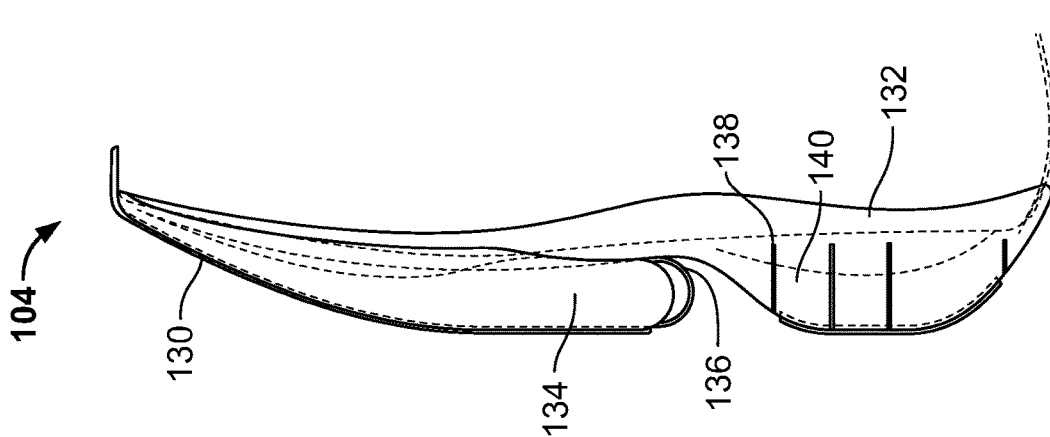

FIG. 3

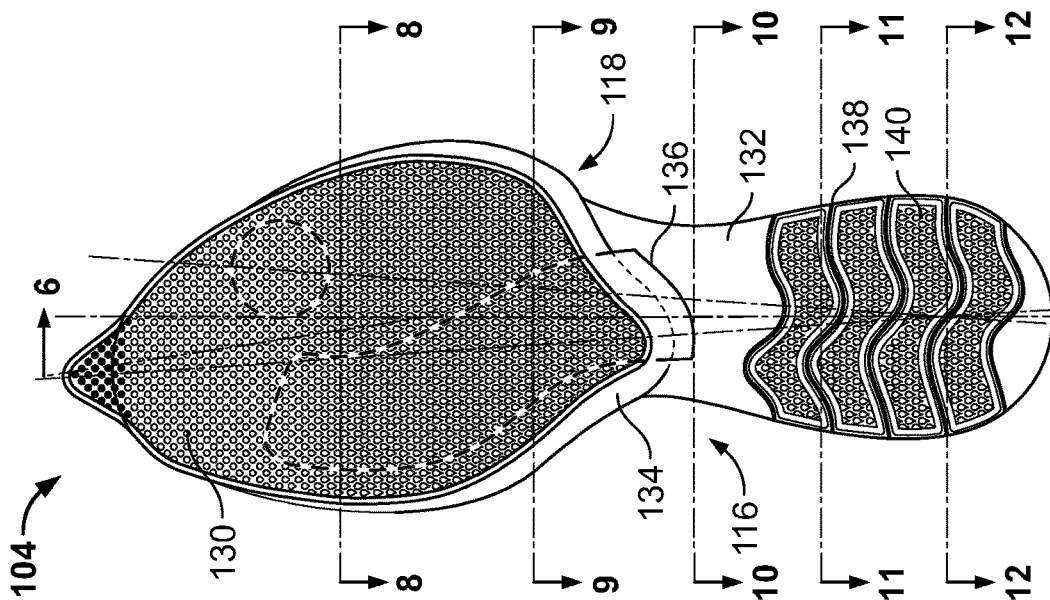

FIG. 4

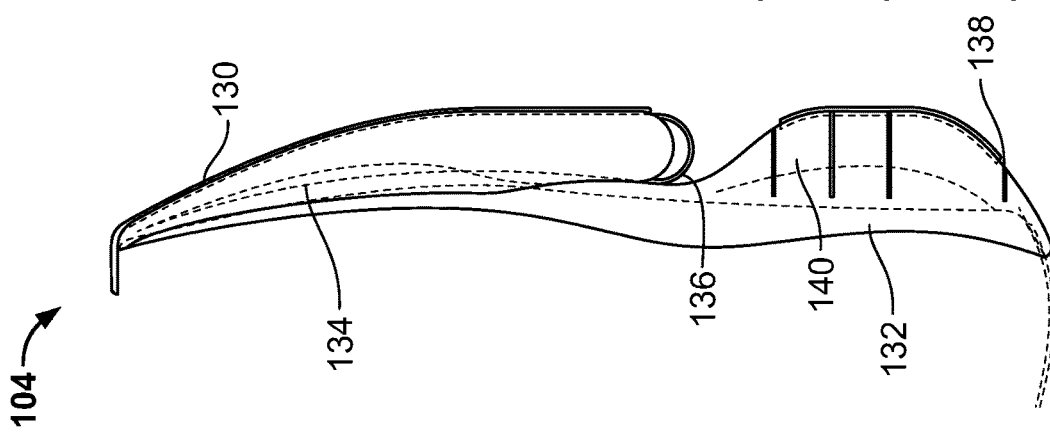

FIG. 5

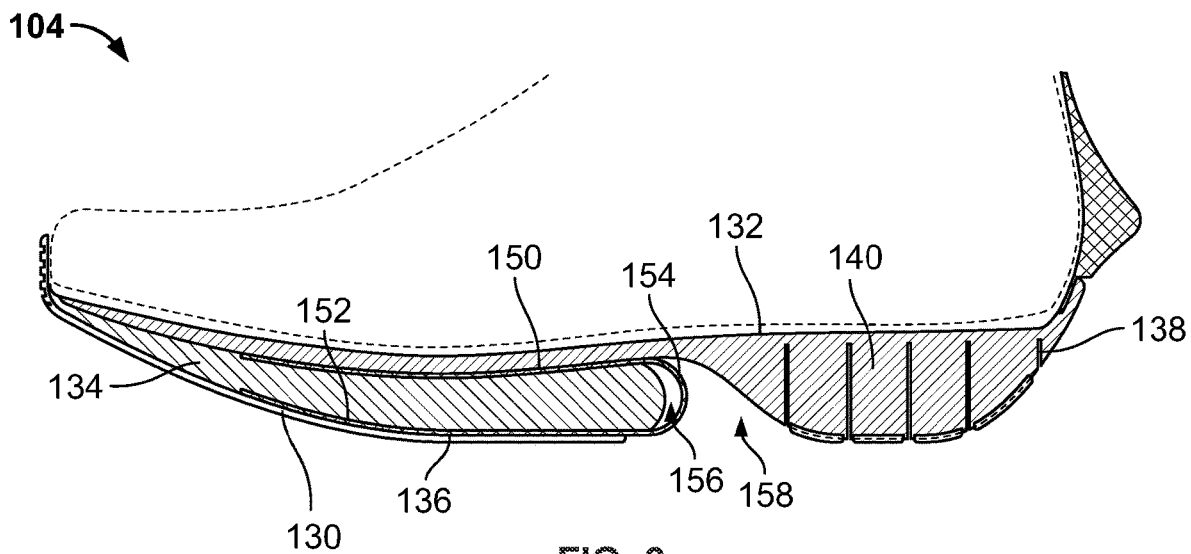

FIG. 6

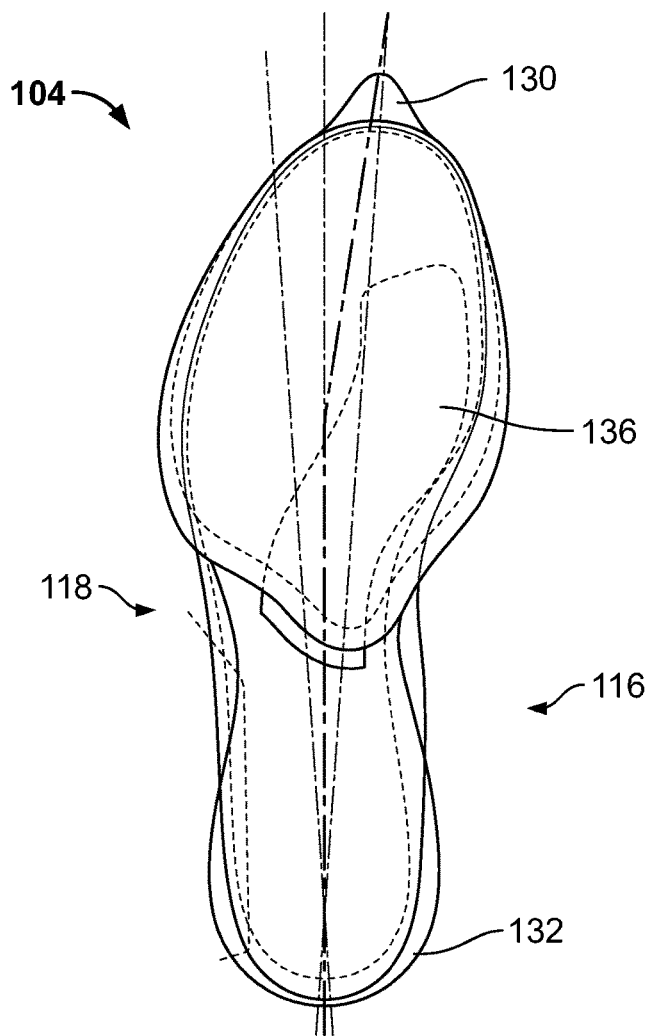

FIG. 7

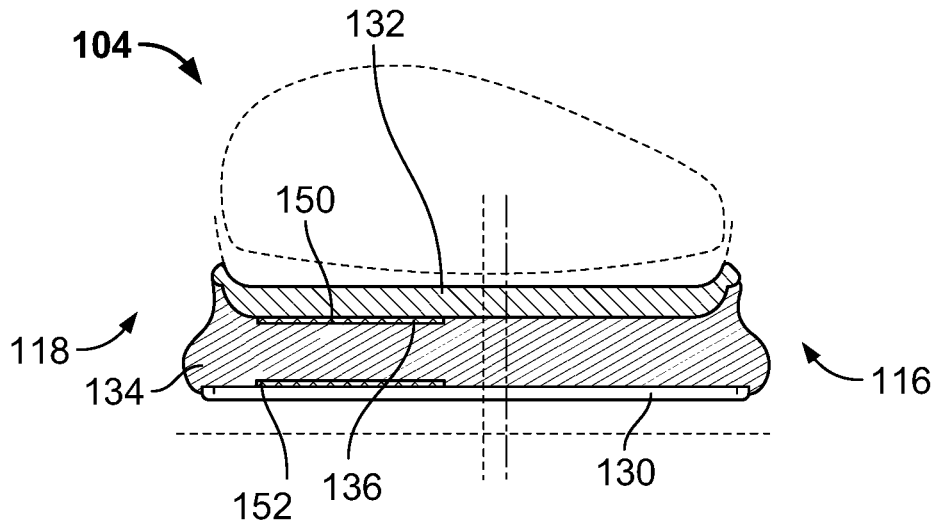

FIG. 8

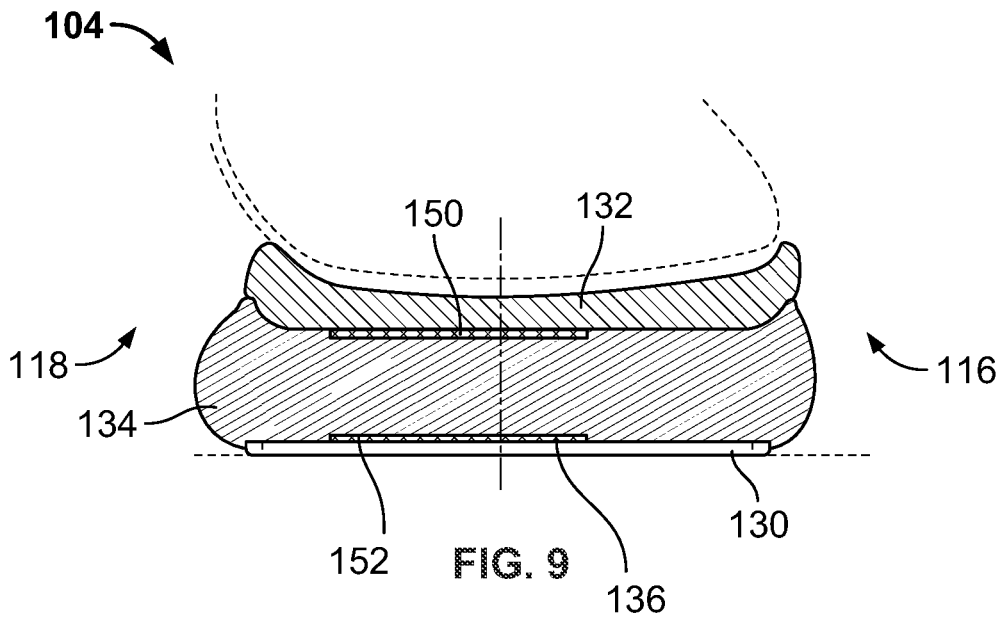

FIG. 9

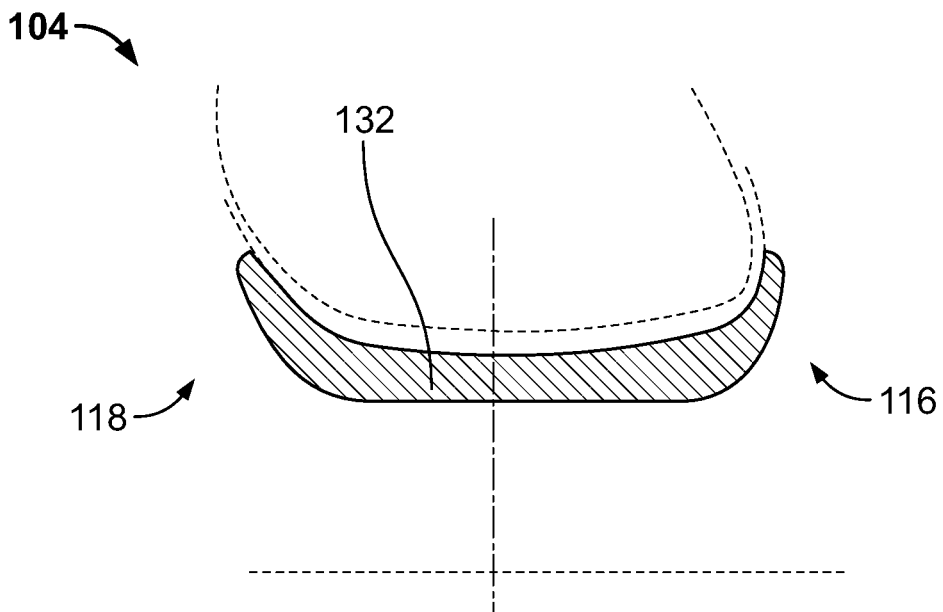

FIG. 10

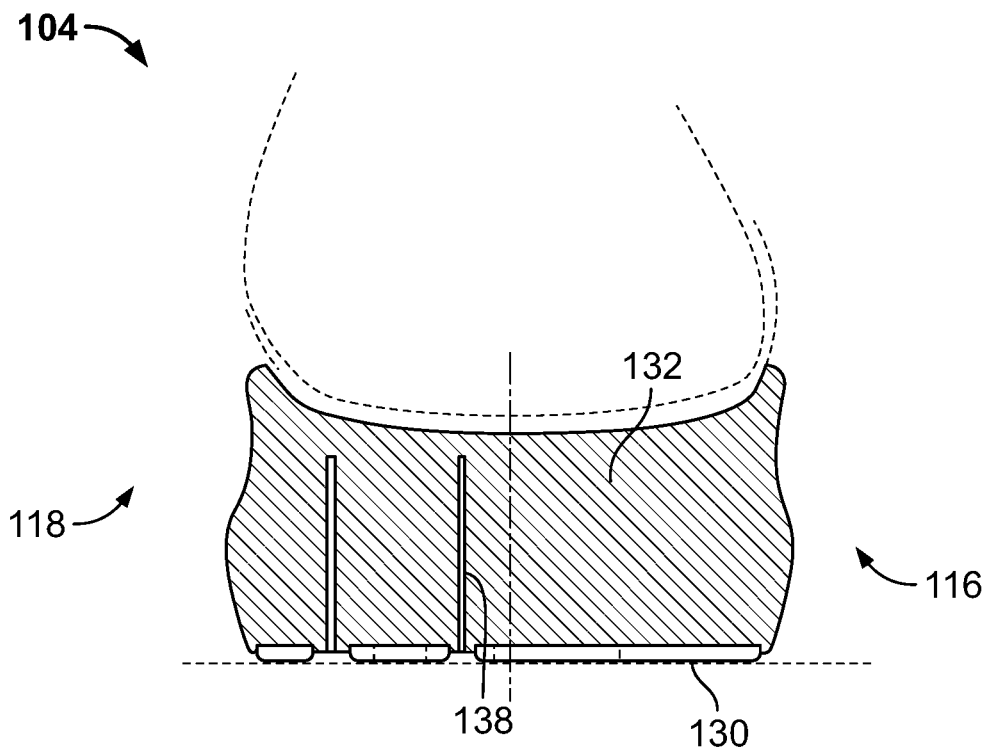

FIG. 11

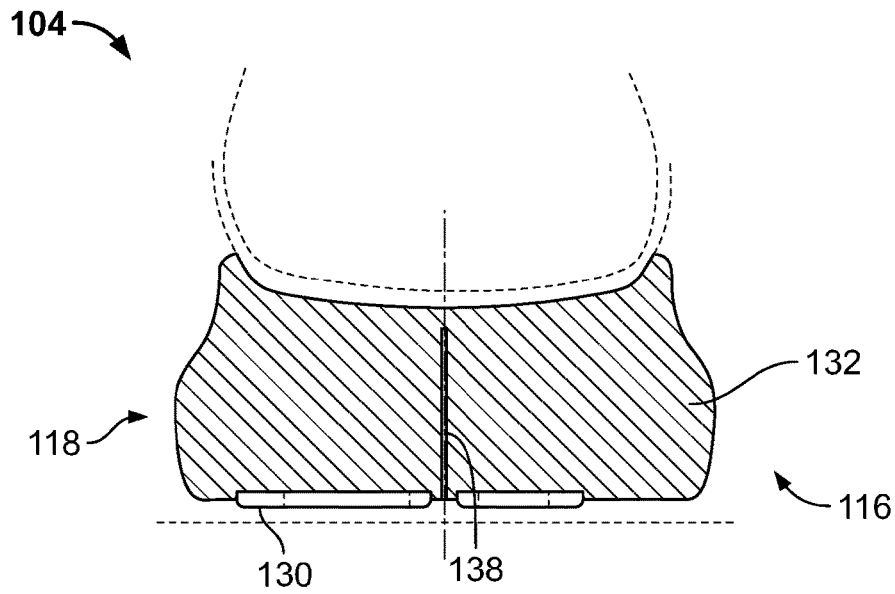

FIG. 12

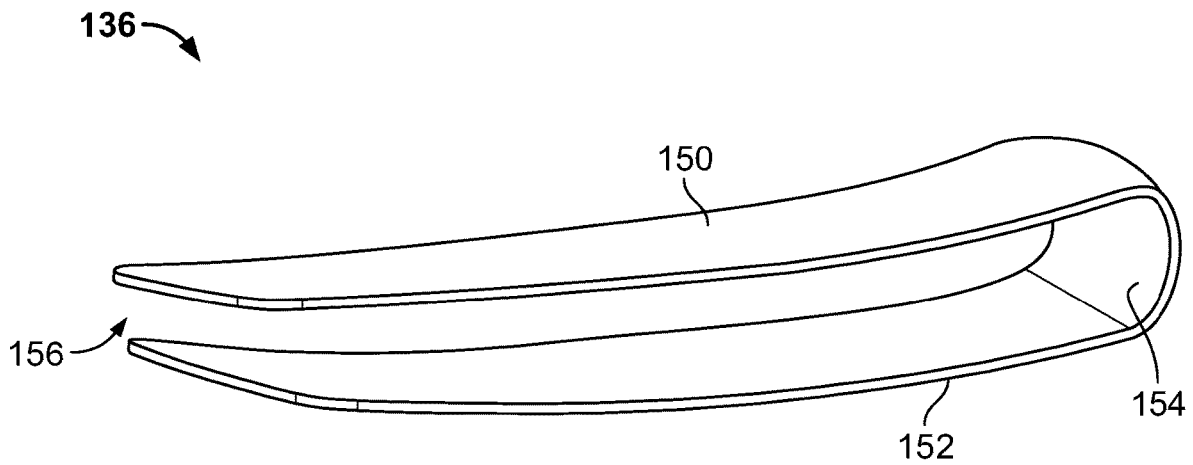

FIG. 13

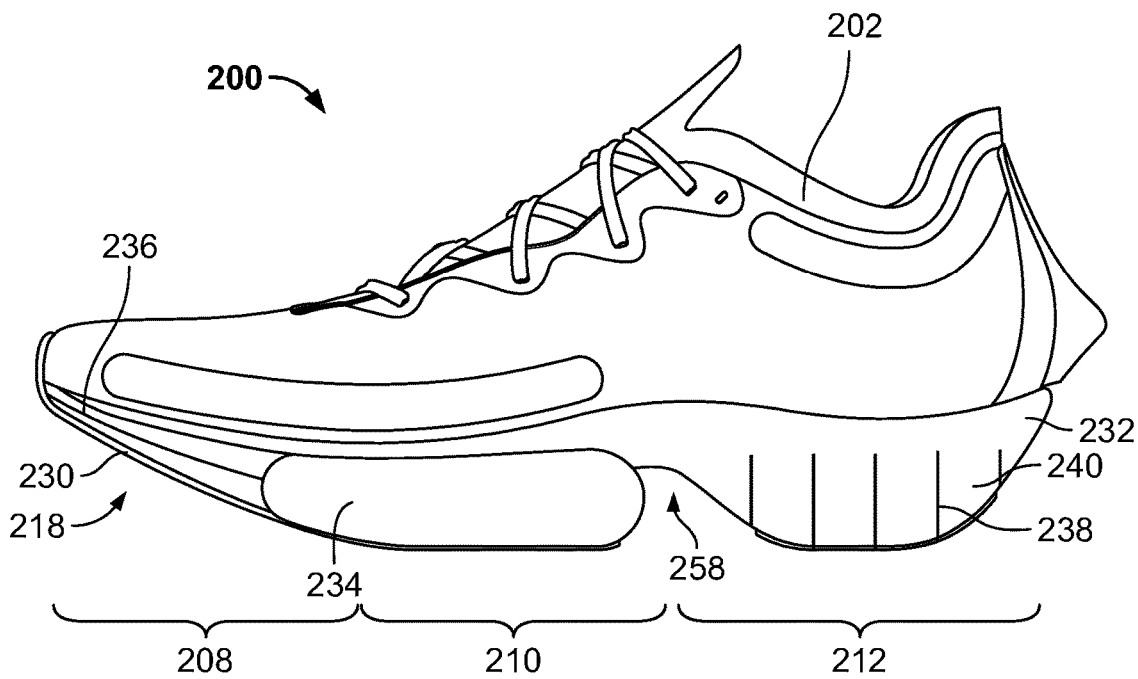

FIG. 14

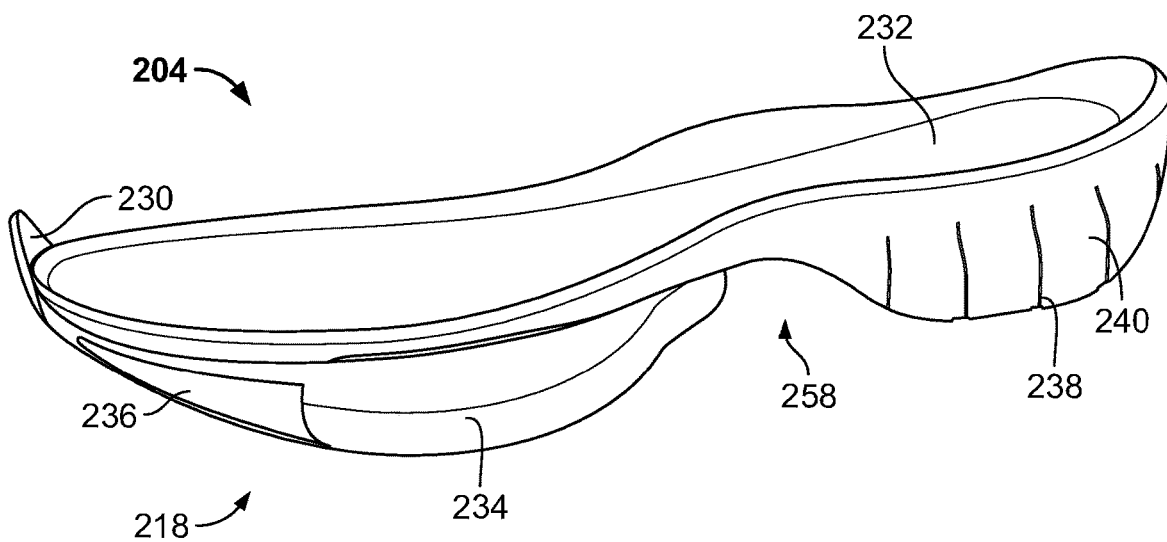

FIG. 15

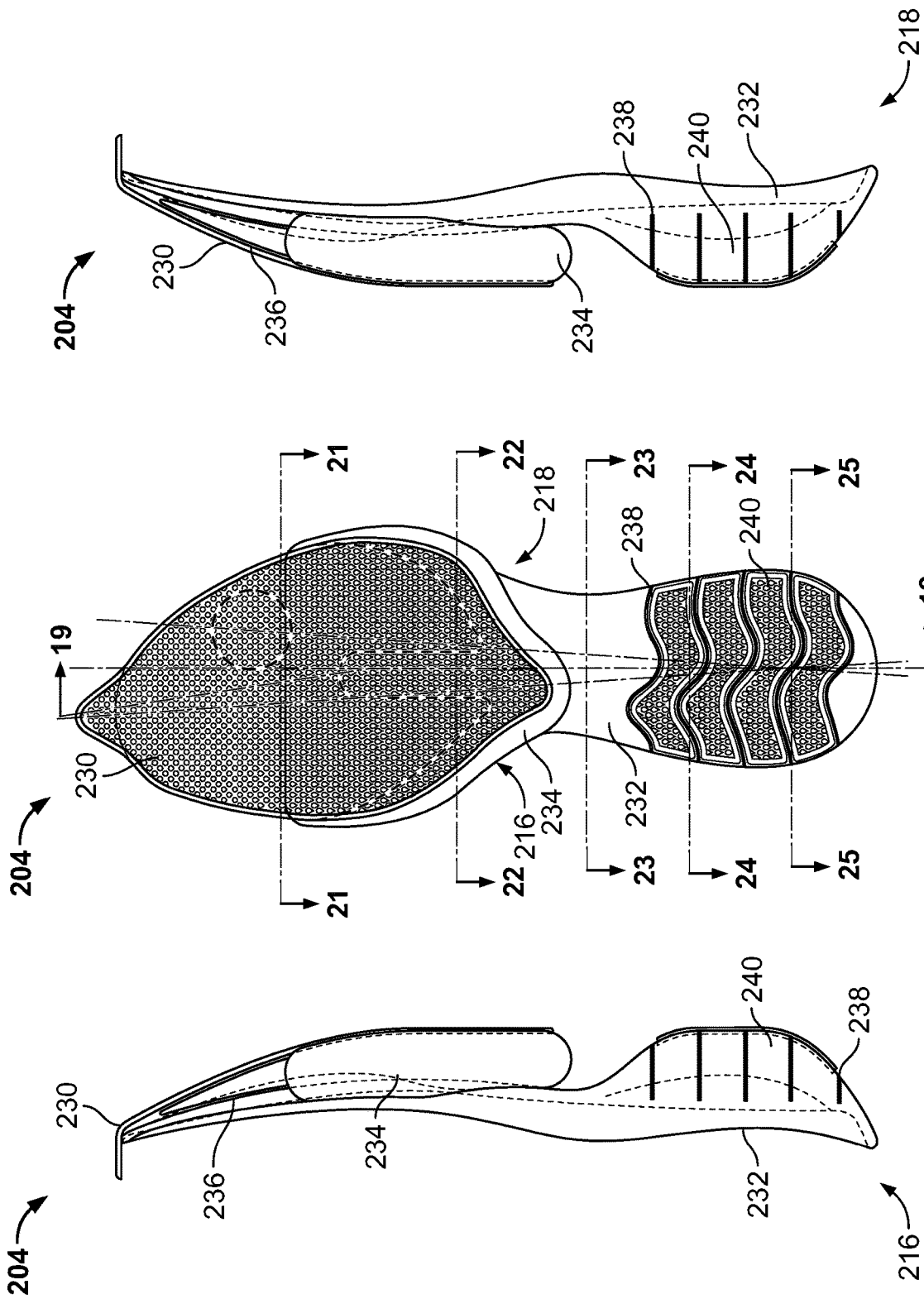

FIG. 16

FIG. 17

FIG. 18

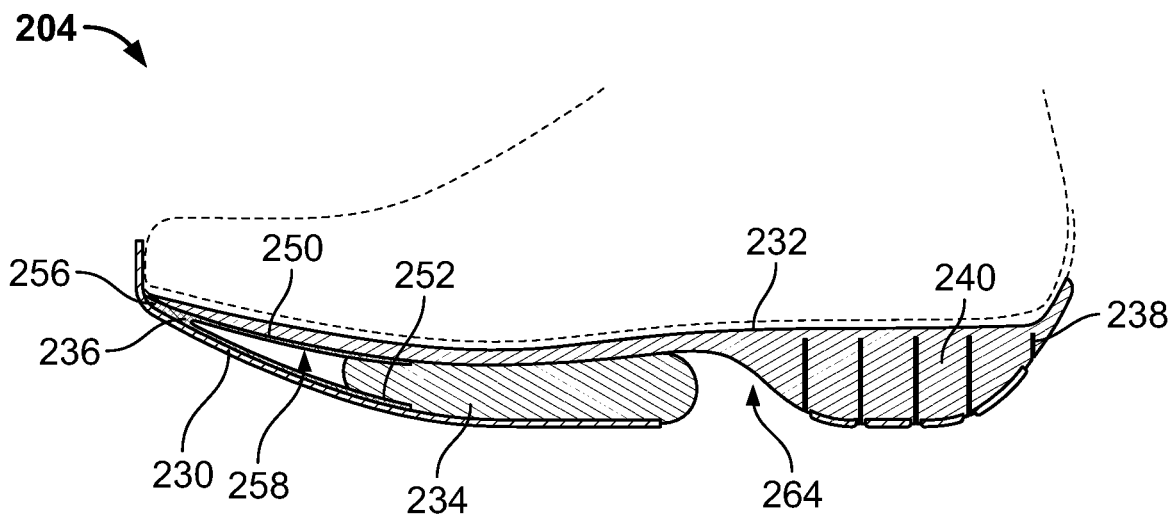

FIG. 19

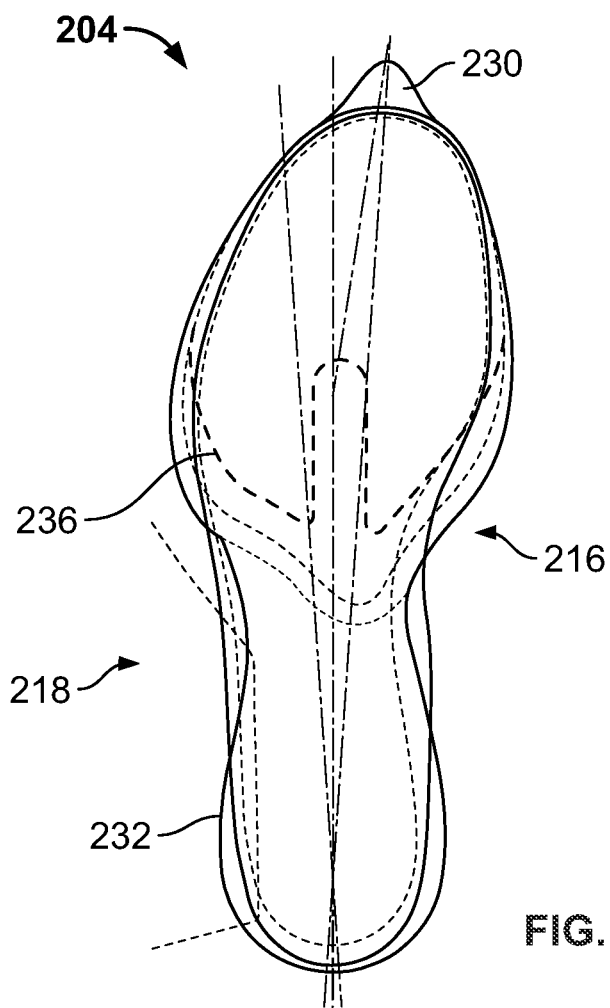

FIG. 20

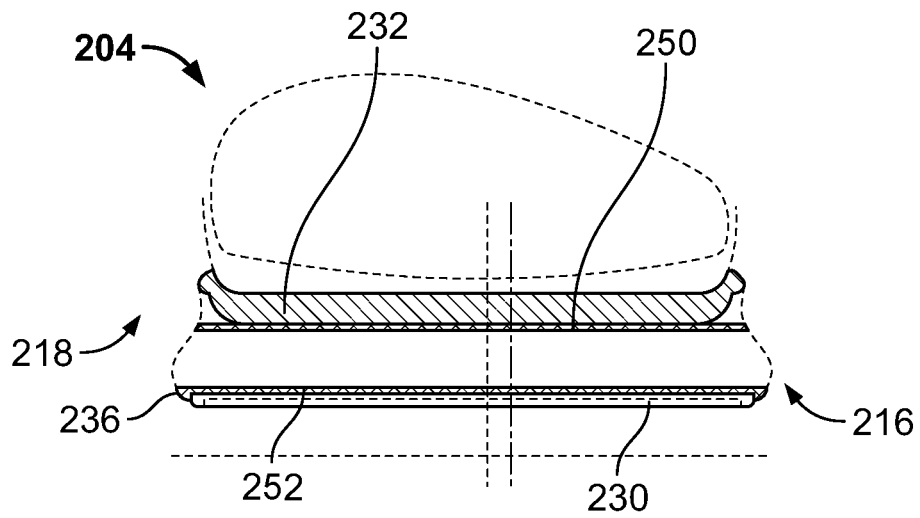

FIG. 21

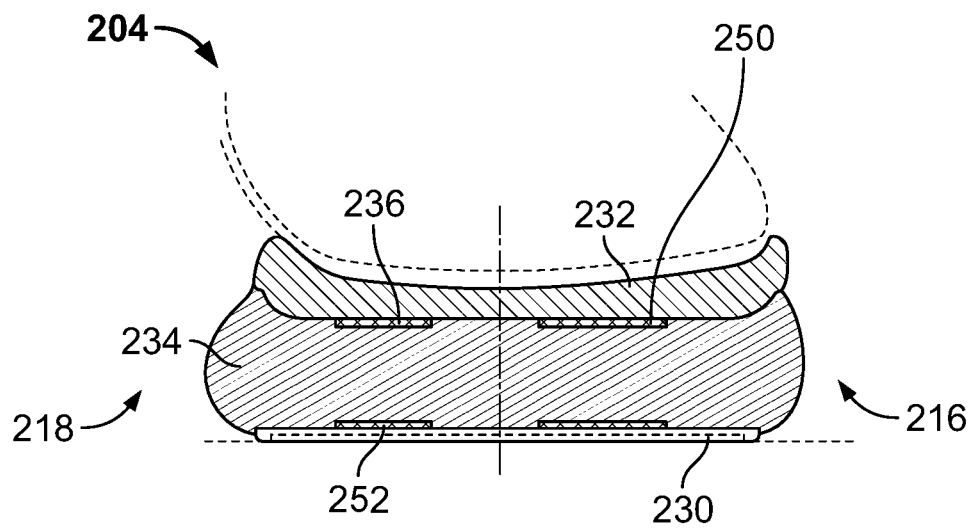

FIG. 22

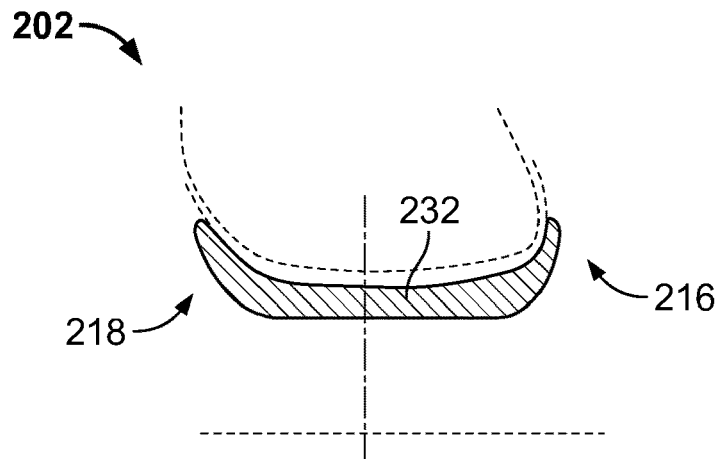

FIG. 23

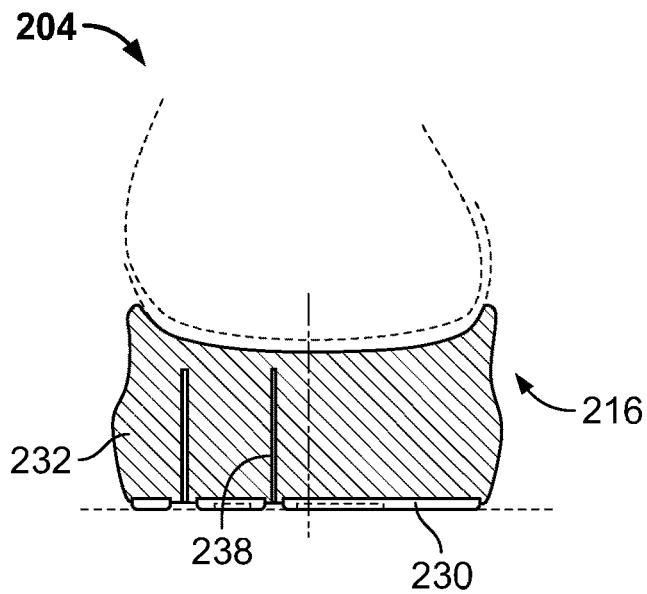

FIG. 24

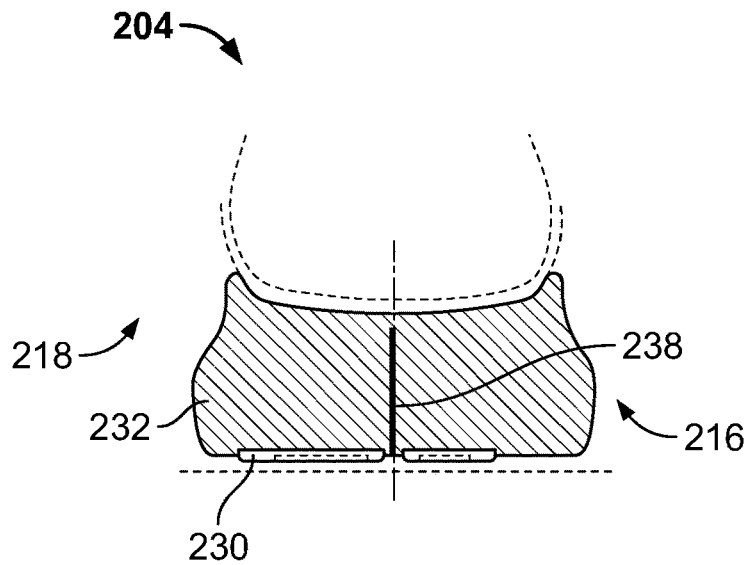

FIG. 25

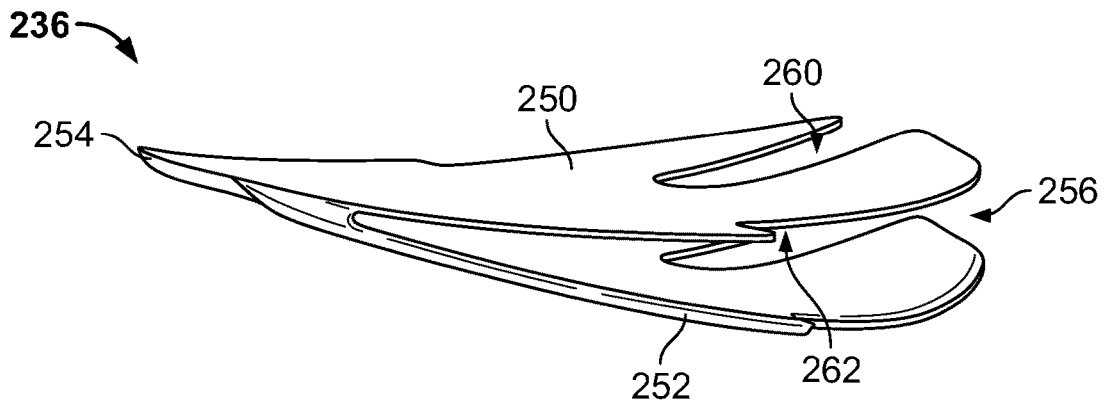

FIG. 26

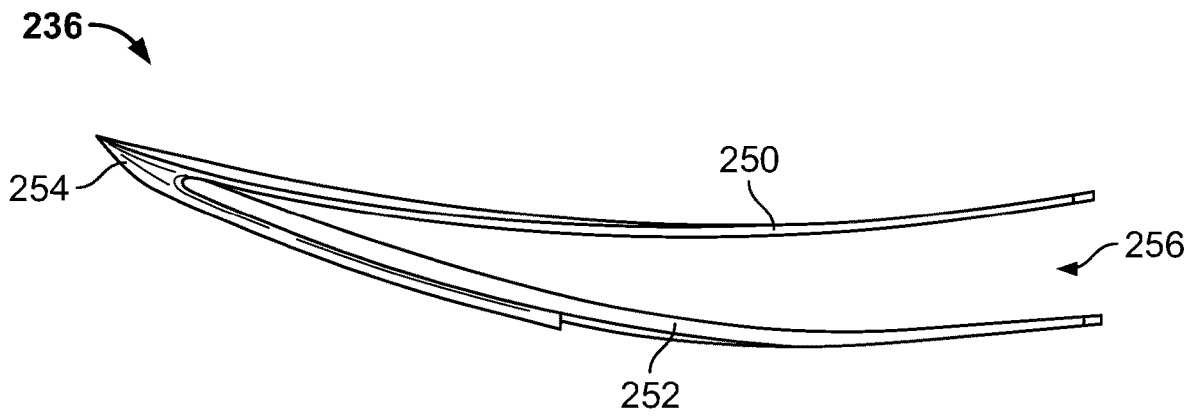

FIG. 27

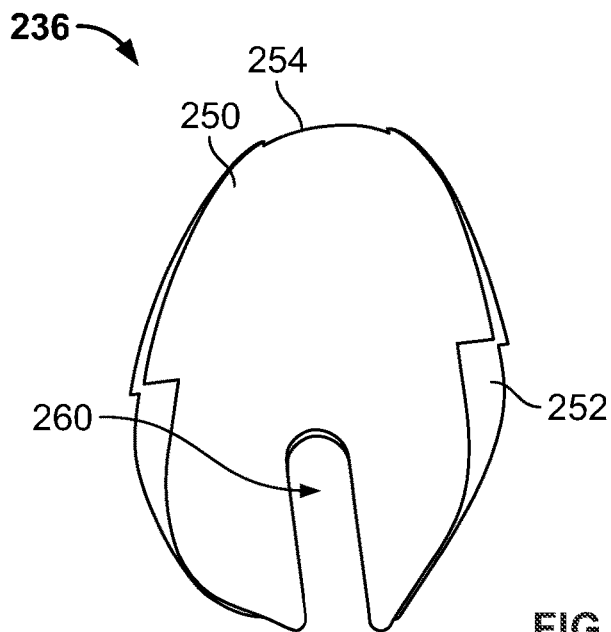

FIG. 28

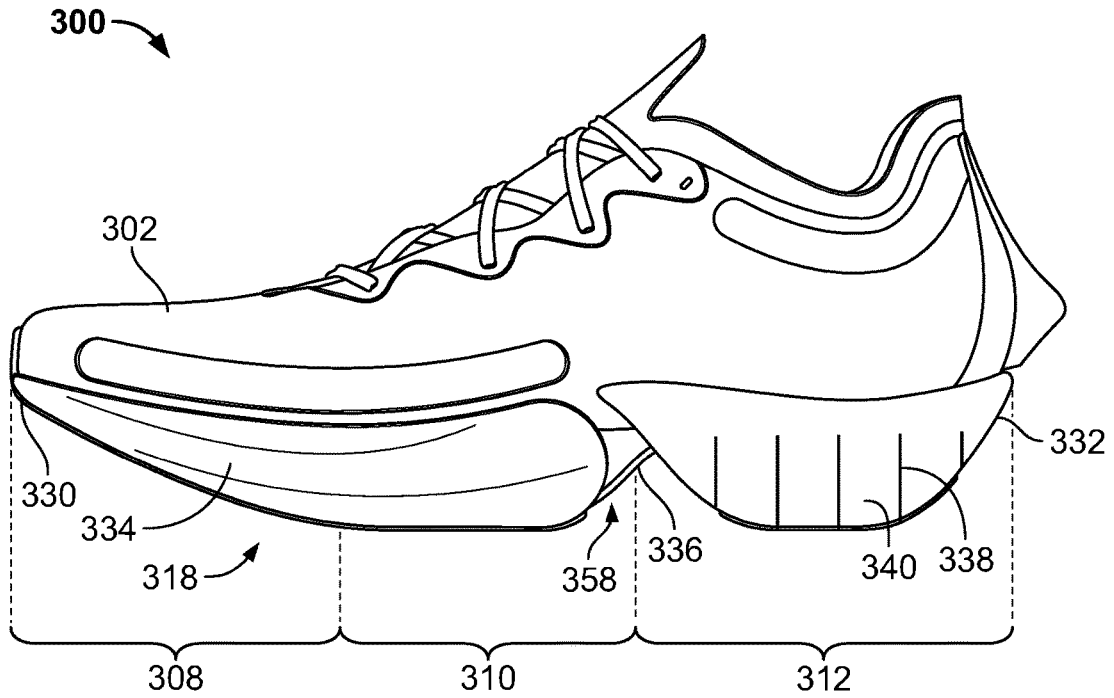

FIG. 29

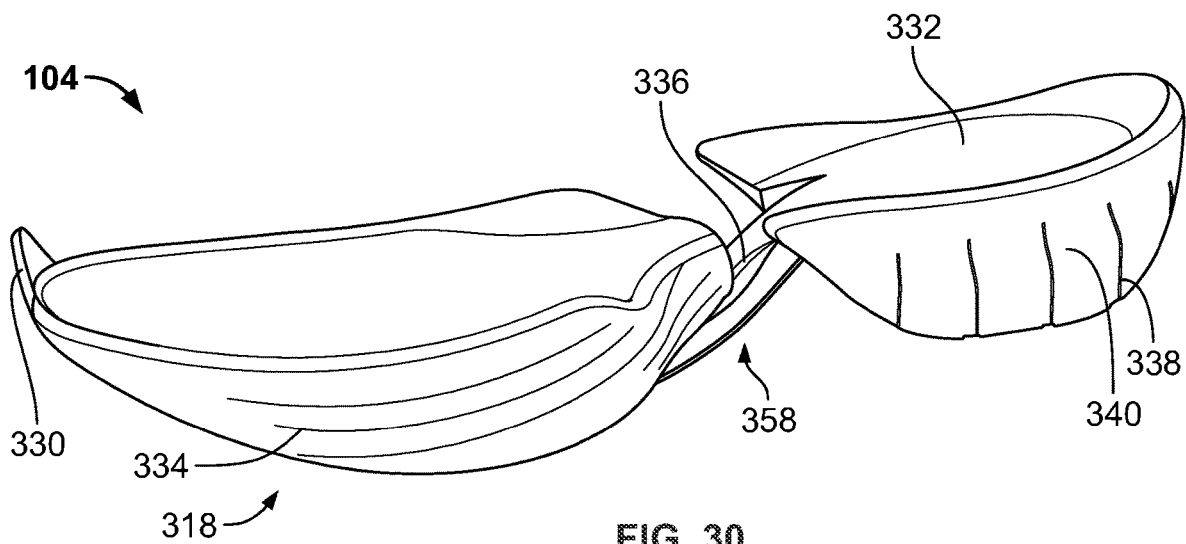

FIG. 30

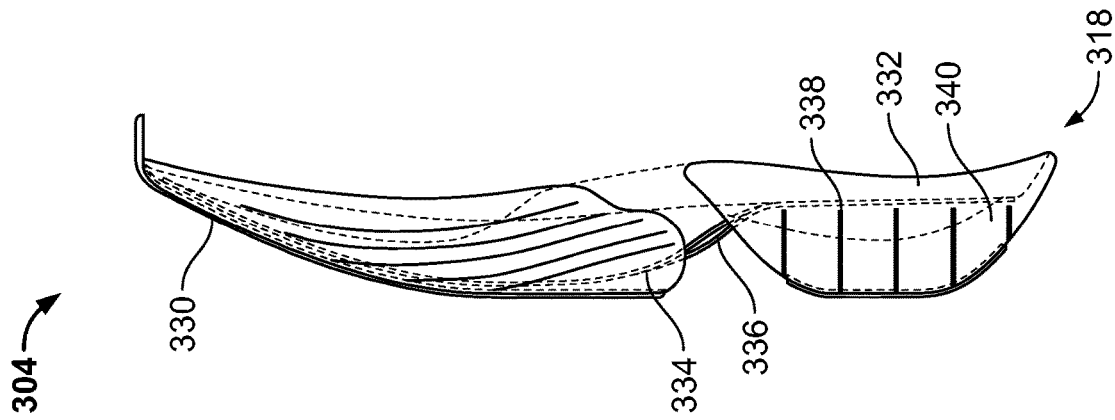

FIG. 31

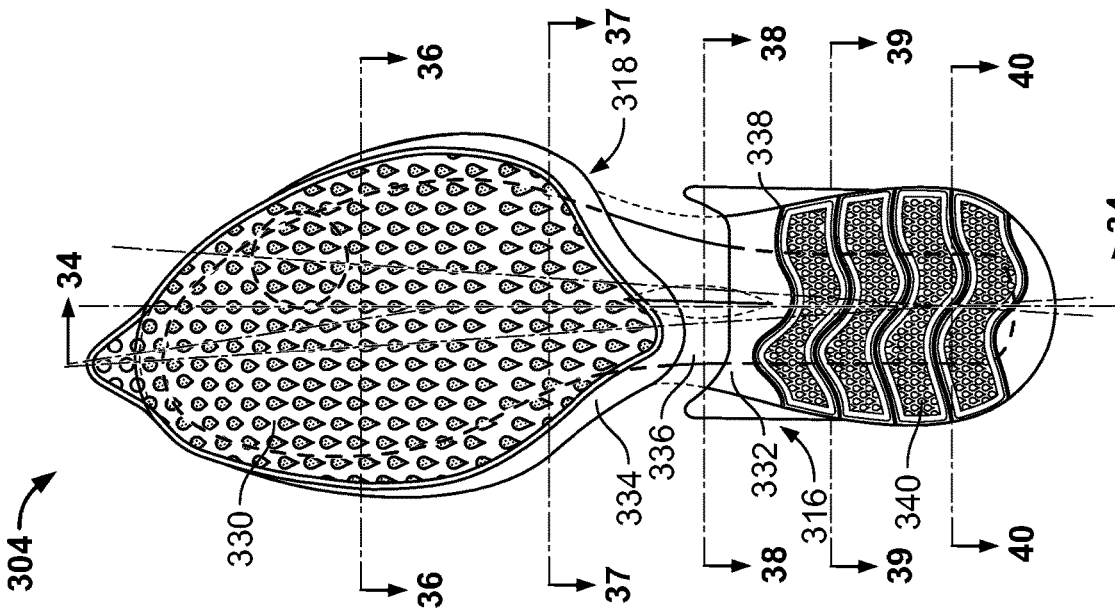

FIG. 32

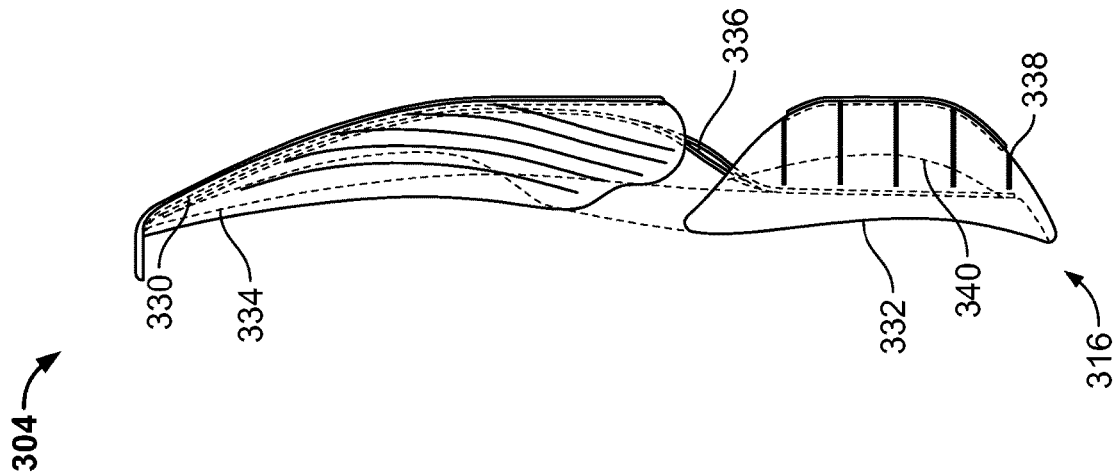

FIG. 33

304

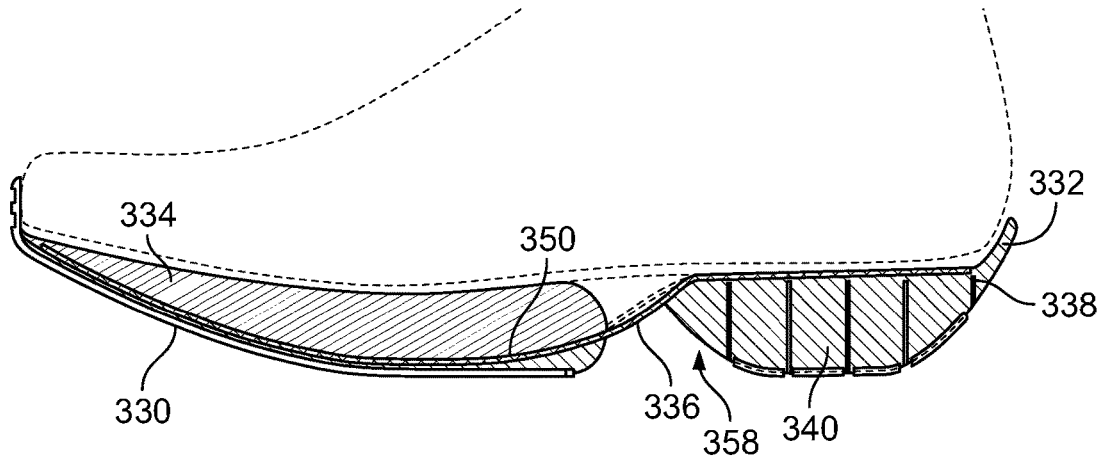

FIG. 34

304

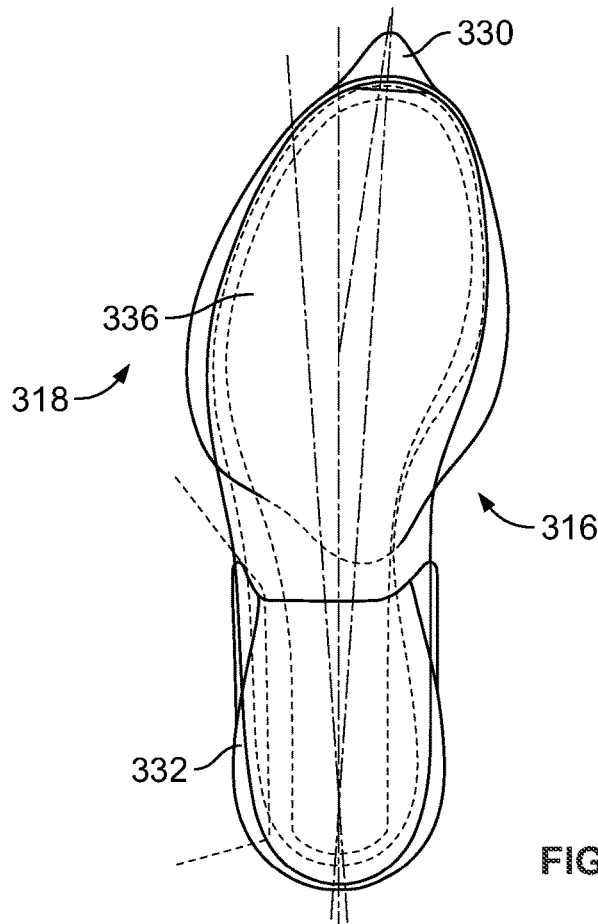

FIG. 35

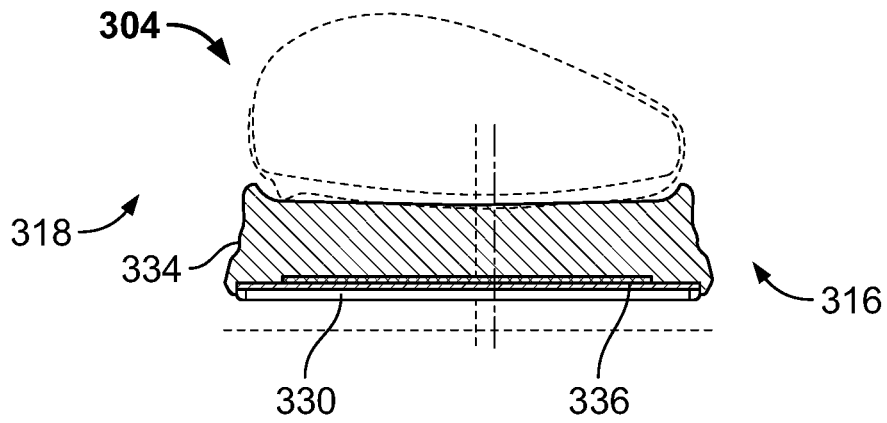

FIG. 36

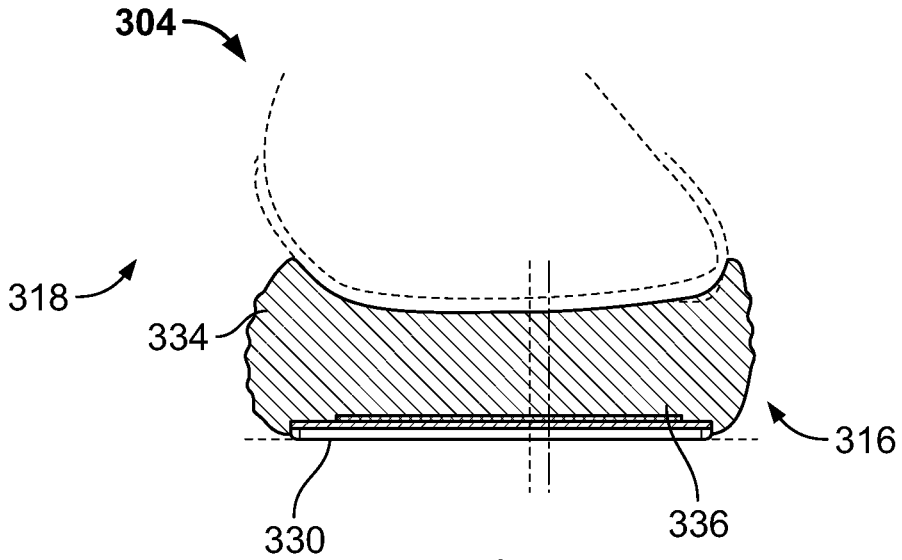

FIG. 37

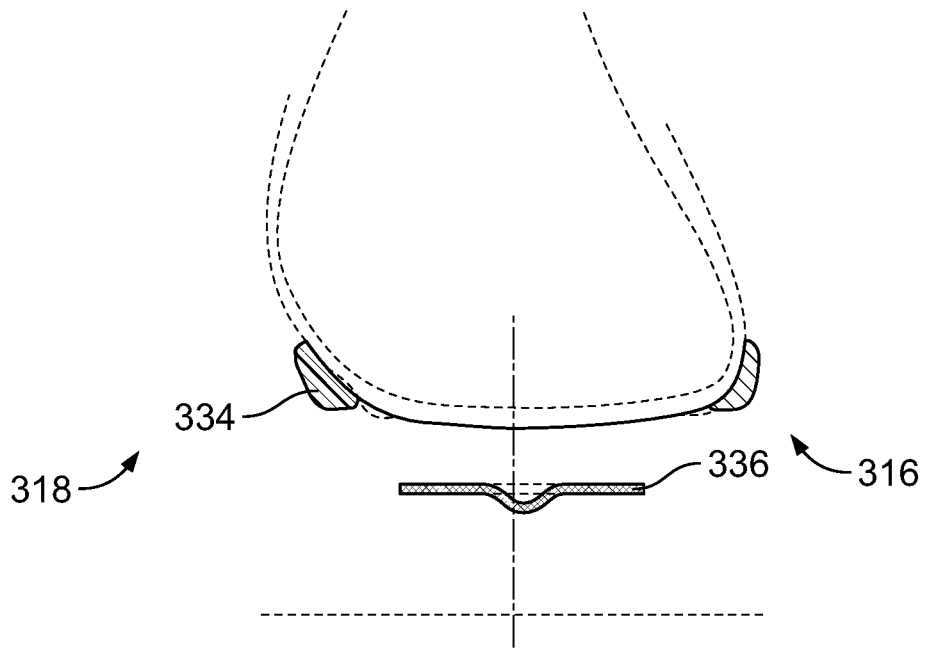

FIG. 38

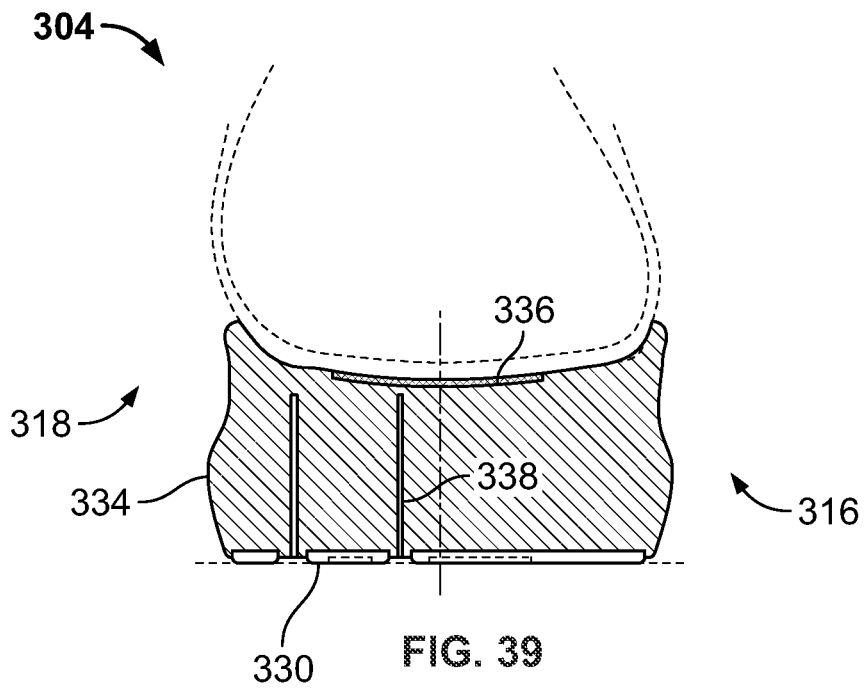

FIG. 39

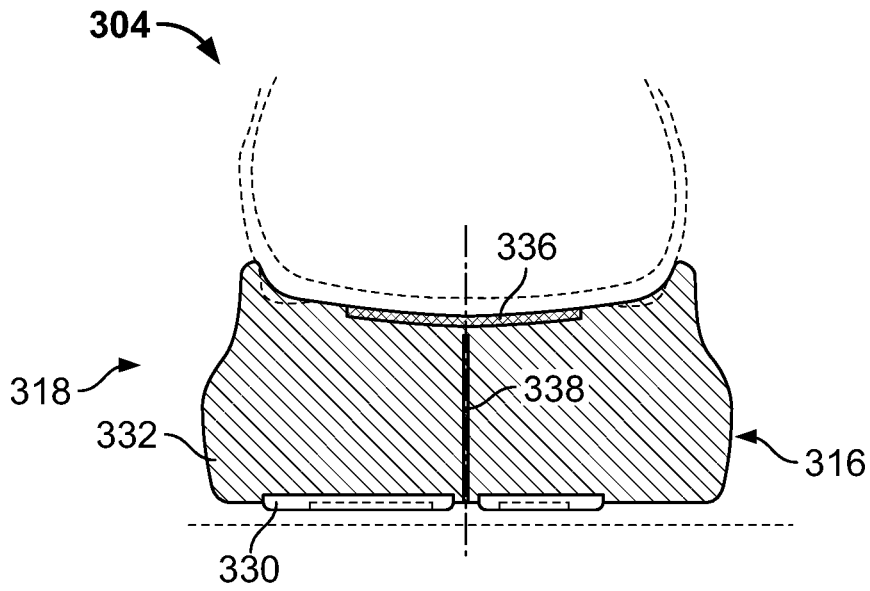

FIG. 40

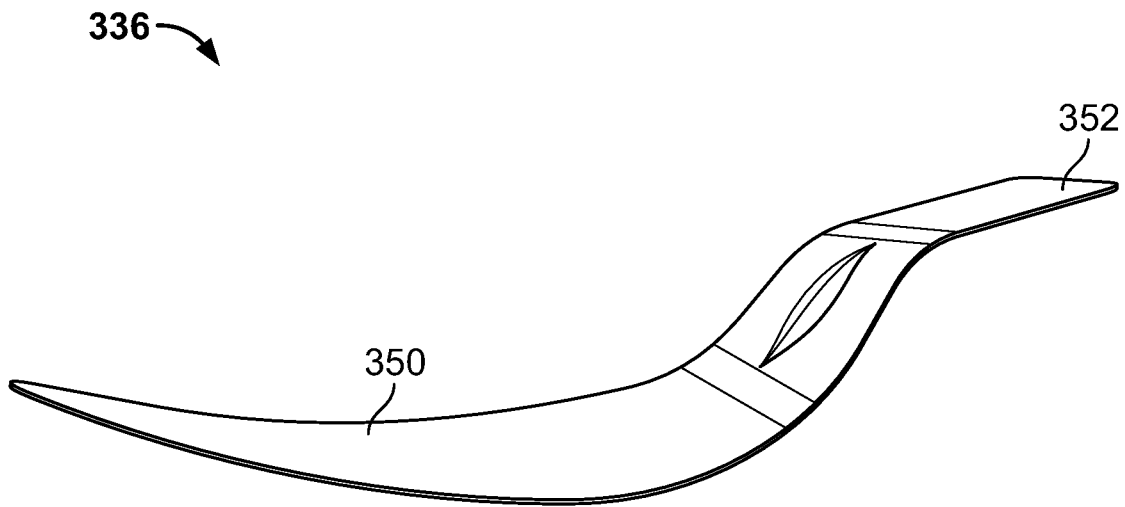

FIG. 41

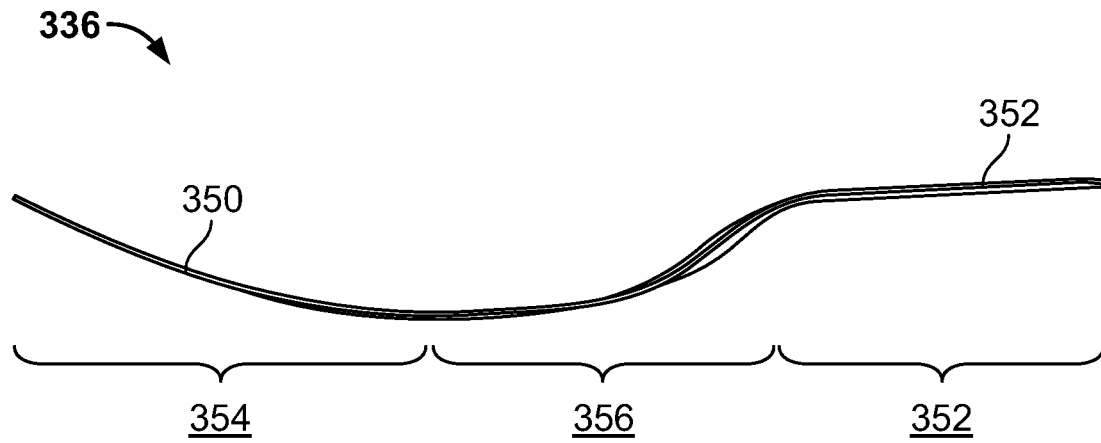

FIG. 42

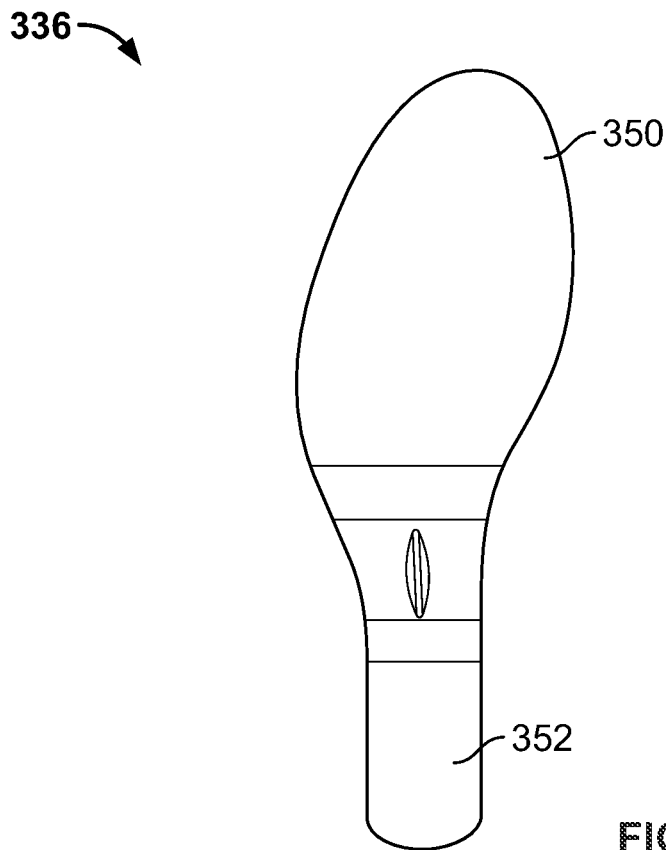

FIG. 43

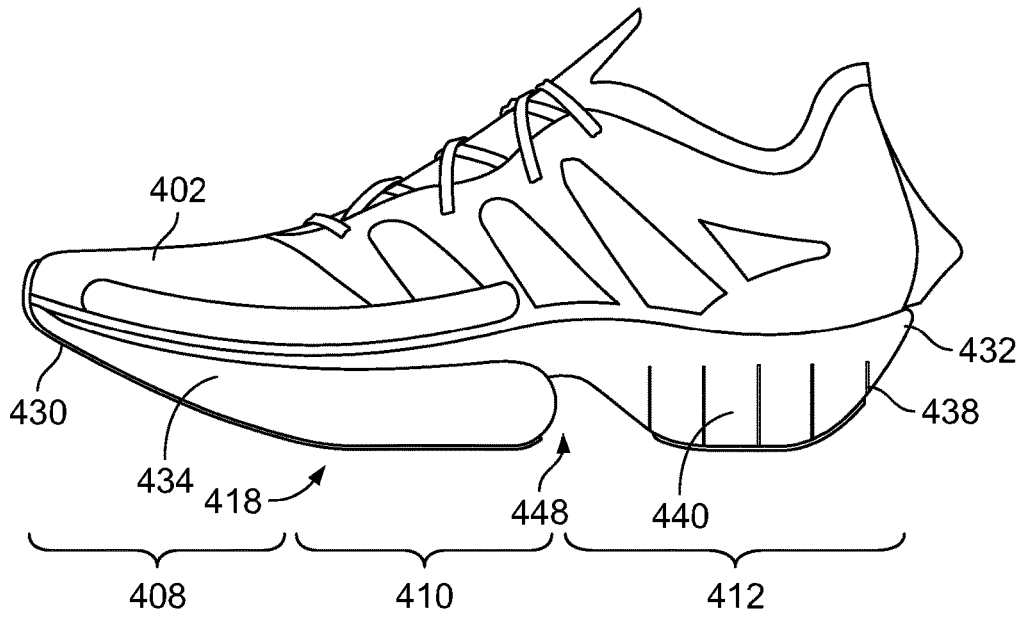

FIG. 44

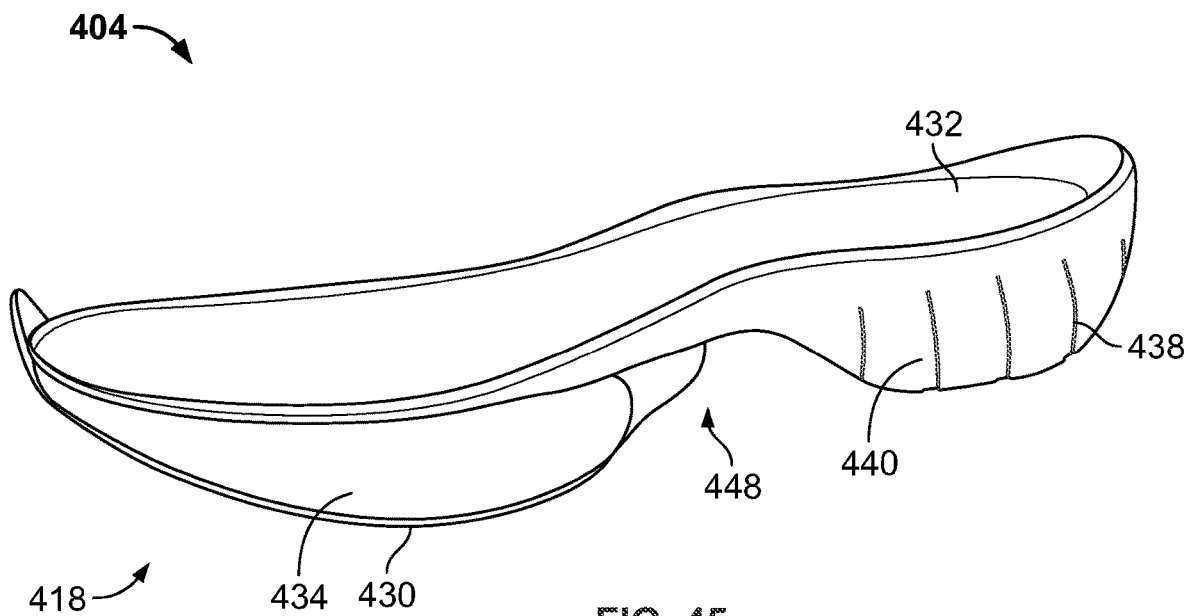

FIG. 45

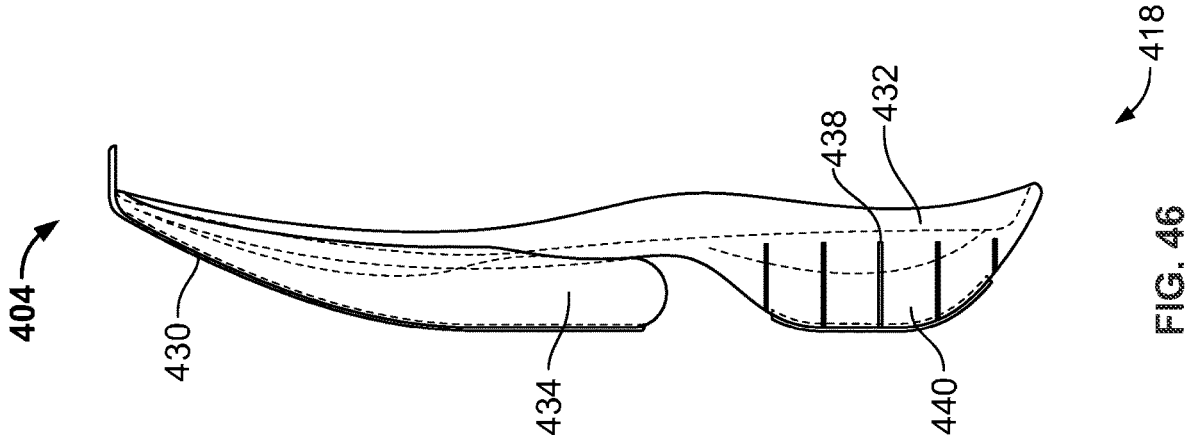

FIG. 46

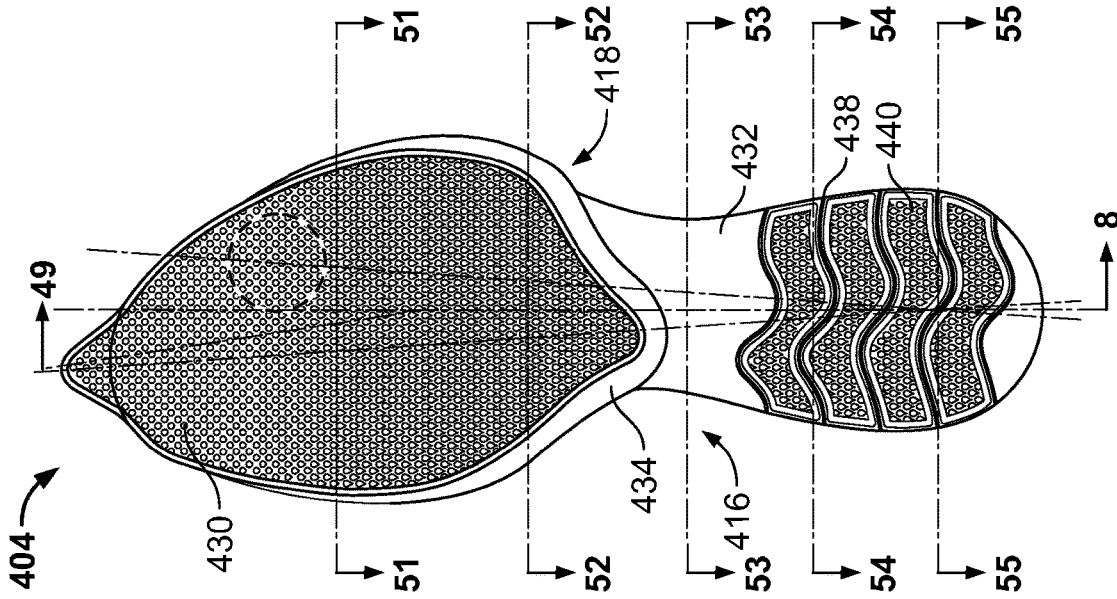

FIG. 47

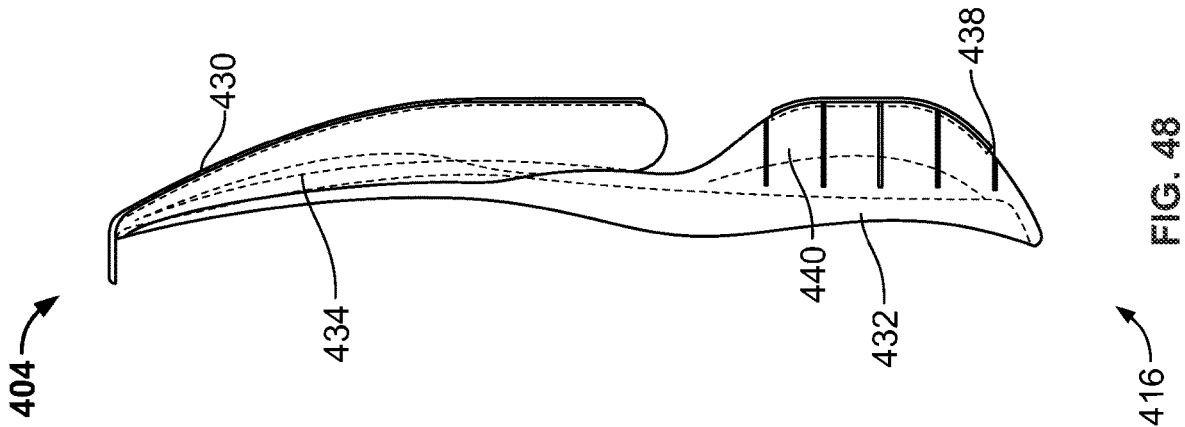

FIG. 48

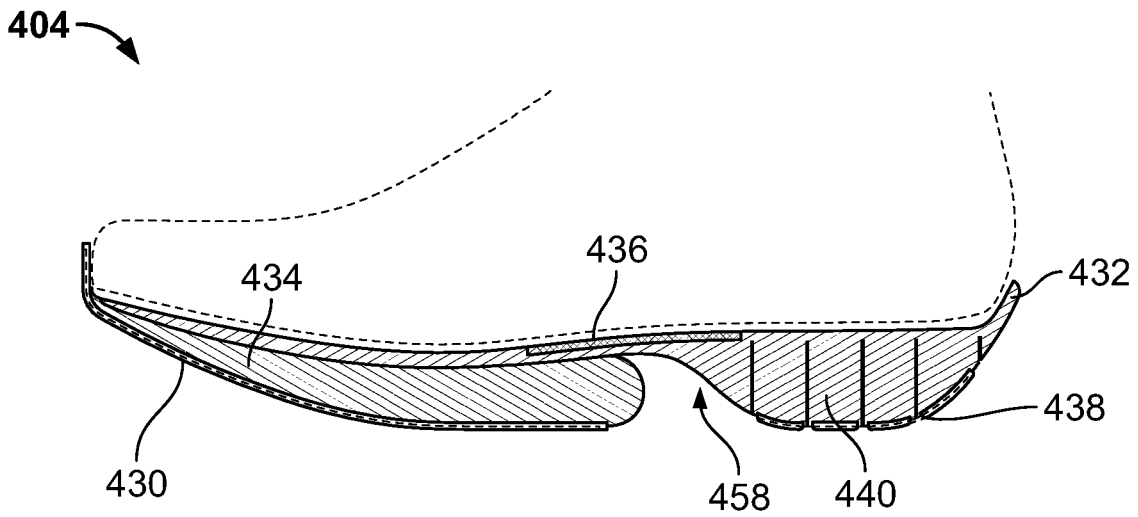

FIG. 49

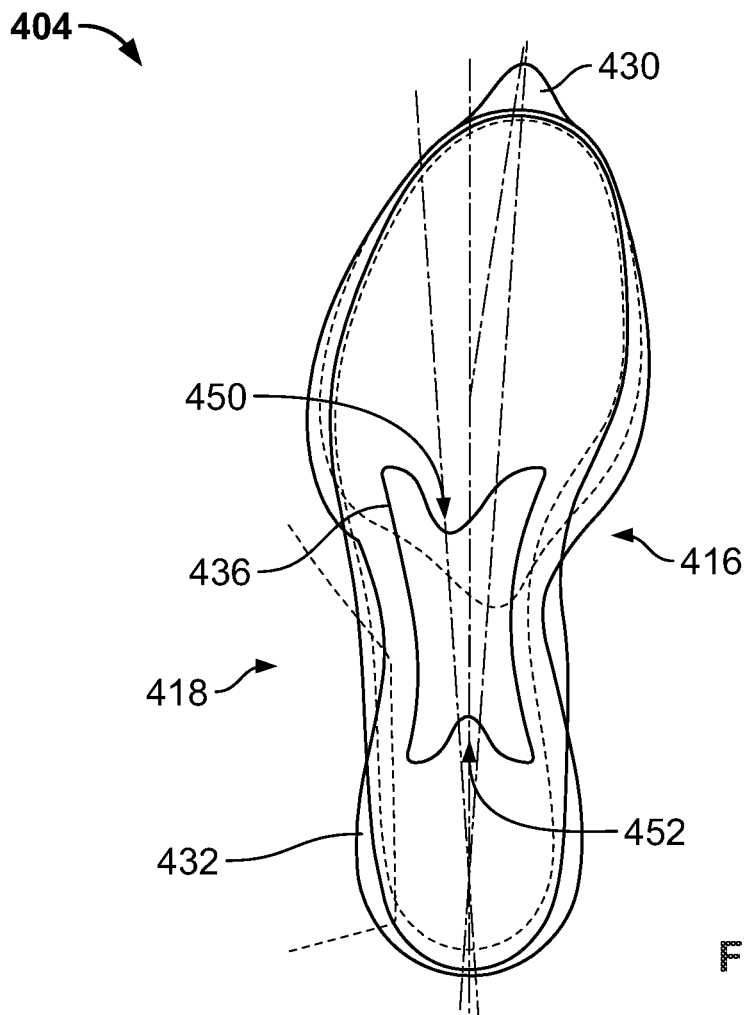

FIG. 50

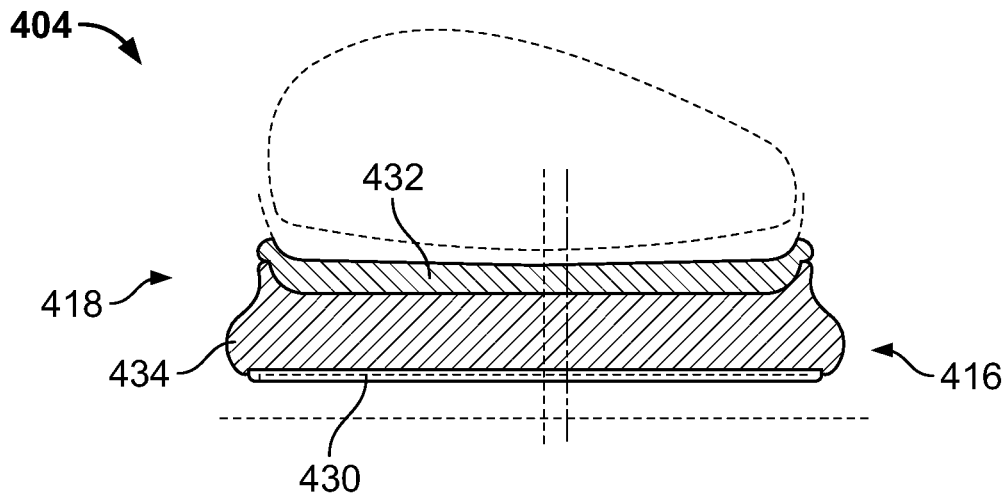

FIG. 51

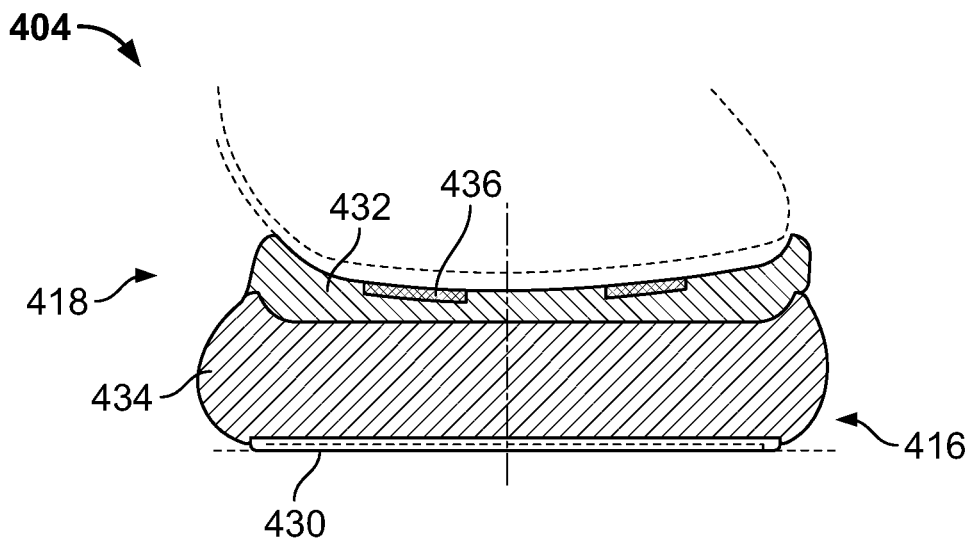

FIG. 52

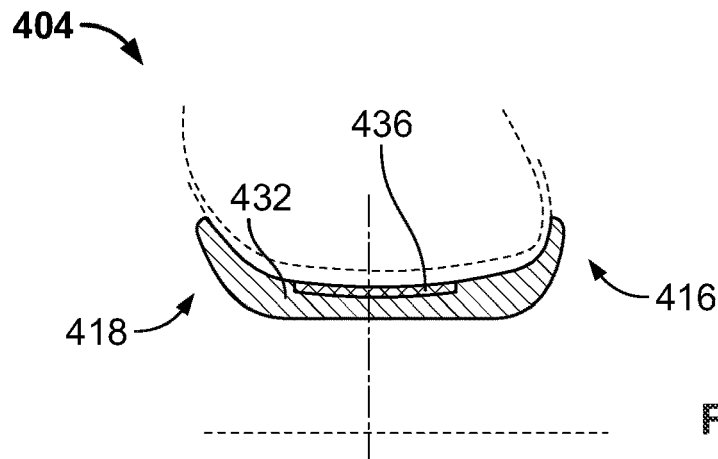

FIG. 53

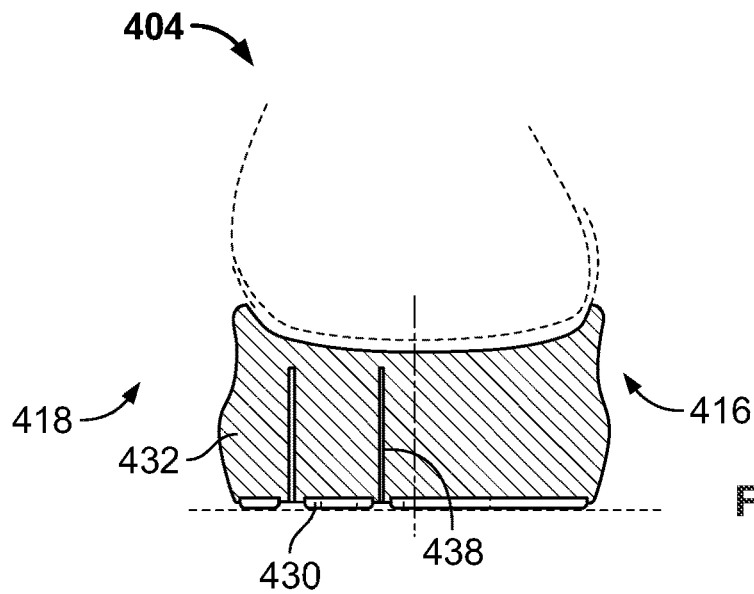

FIG. 54

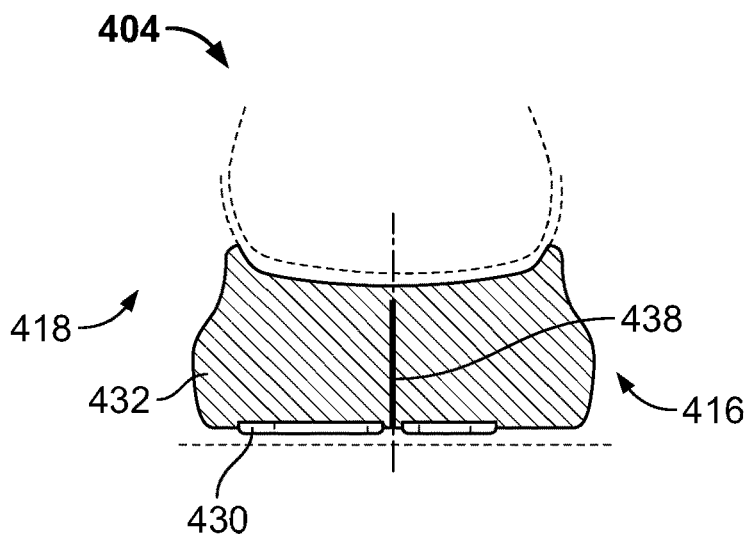

FIG. 55

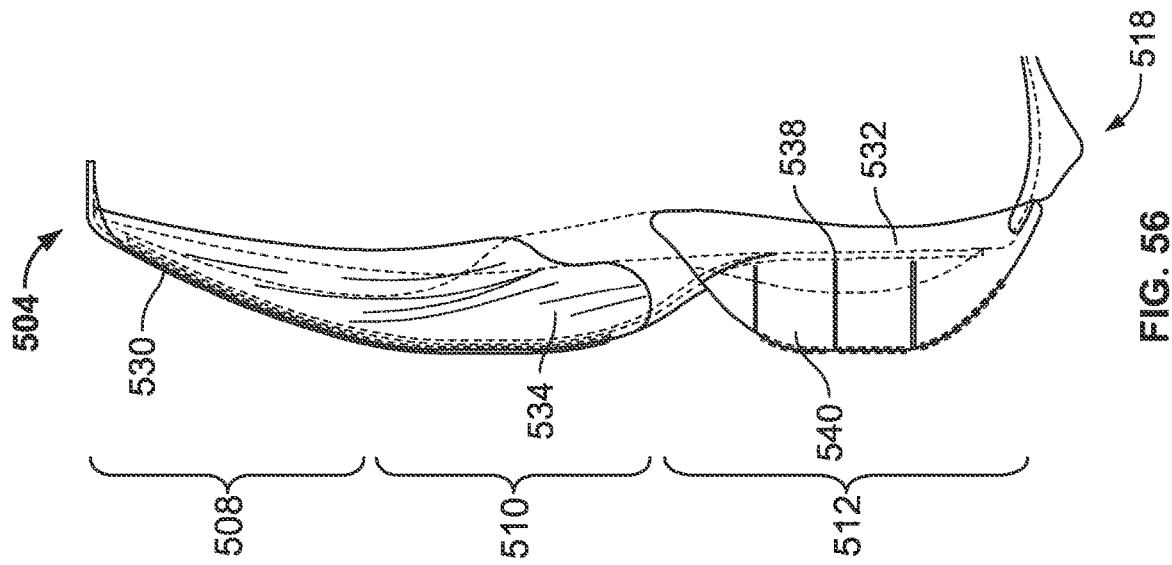

FIG. 56

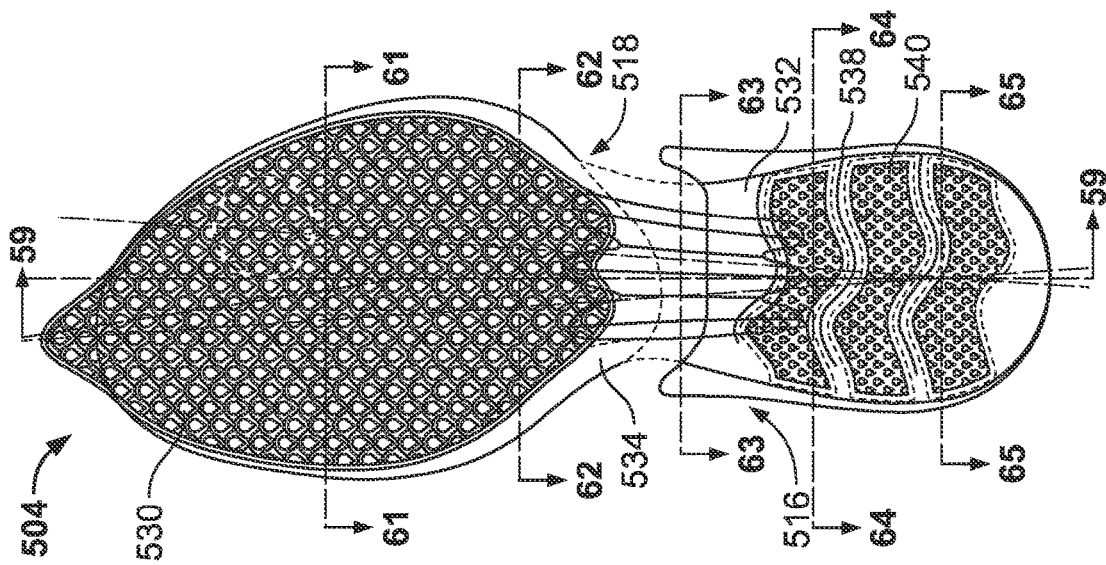

FIG. 57

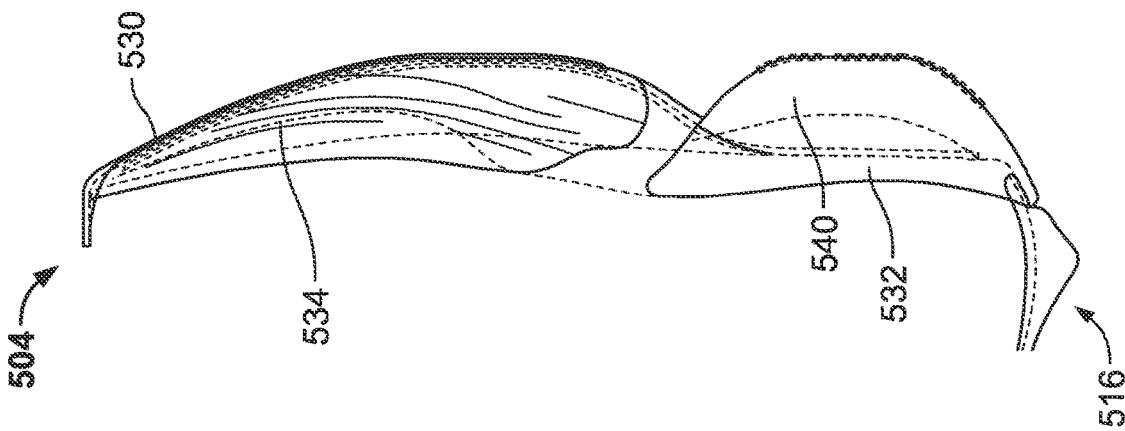

FIG. 58

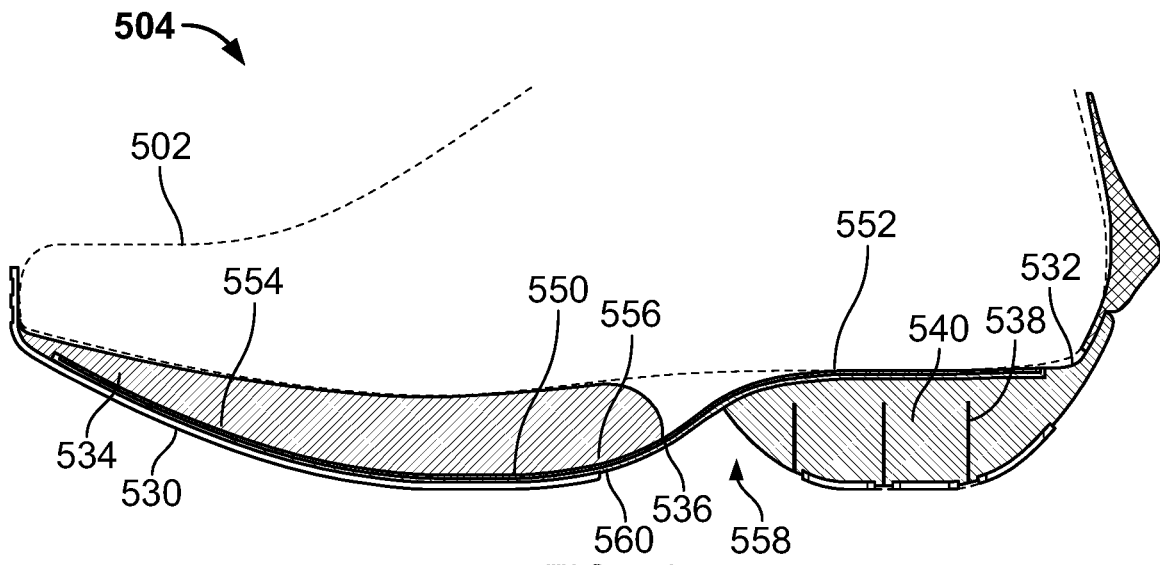

FIG. 59

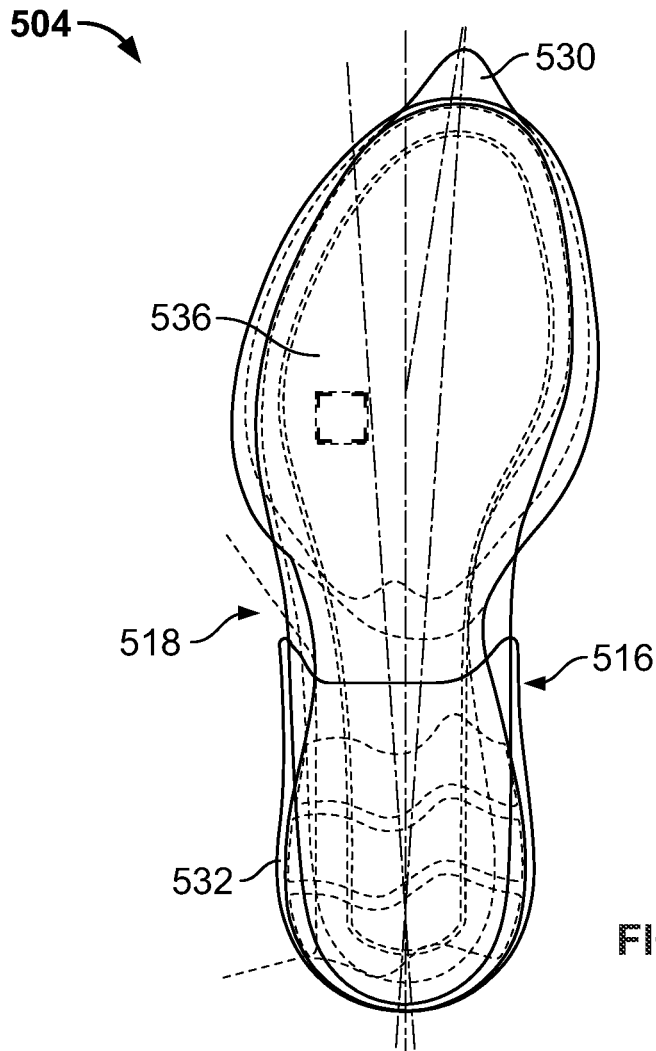

FIG. 60

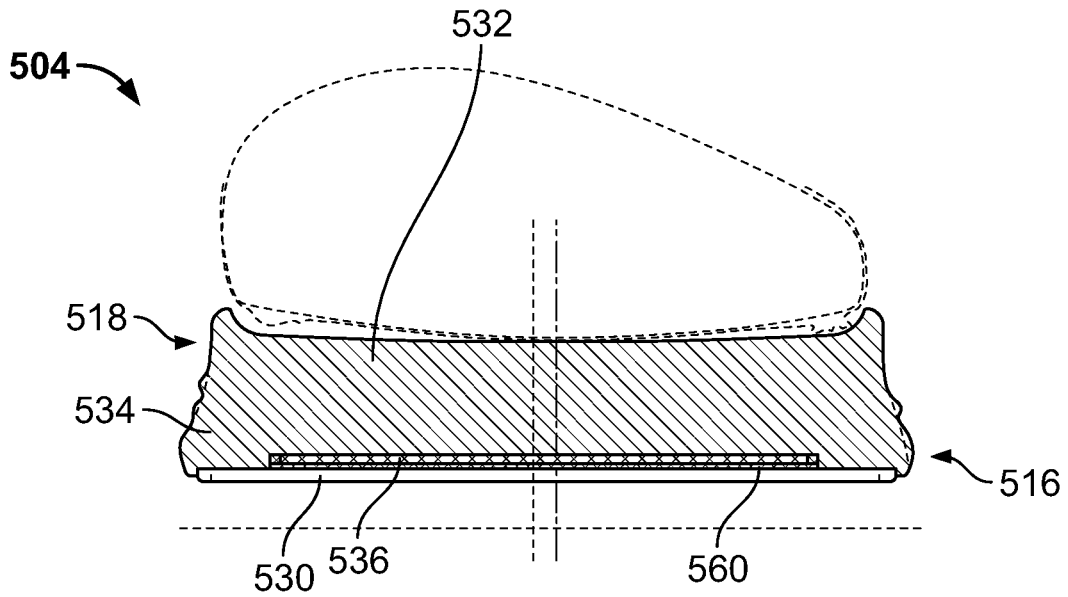

FIG. 61

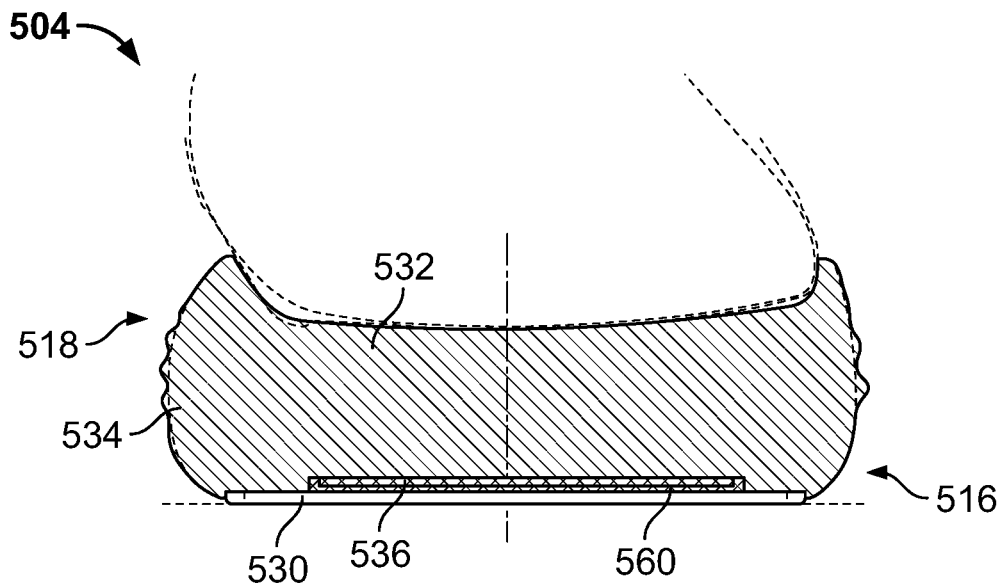

FIG. 62

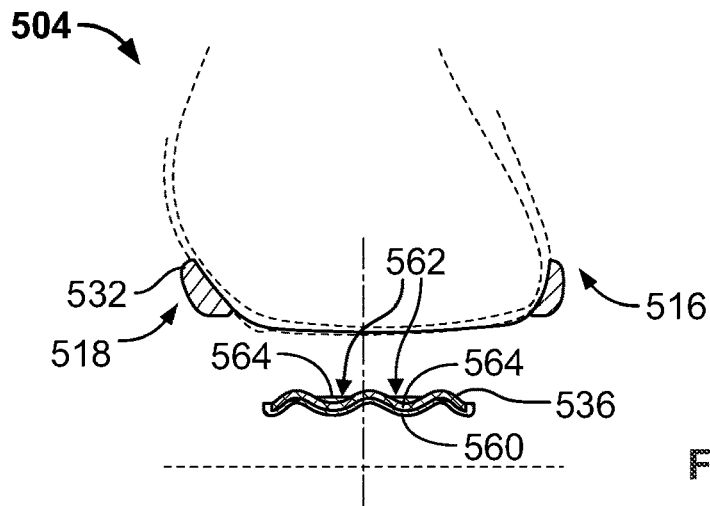

FIG. 63

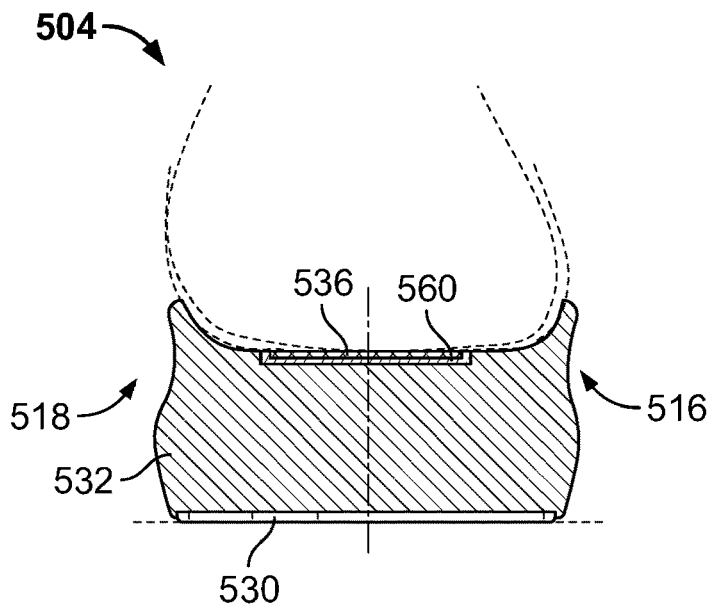

FIG. 64

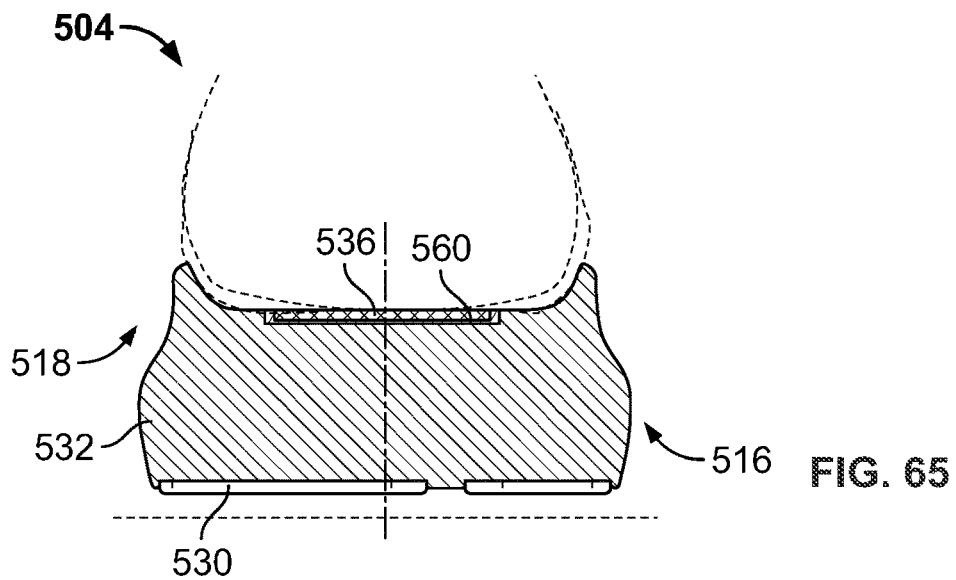

FIG. 65

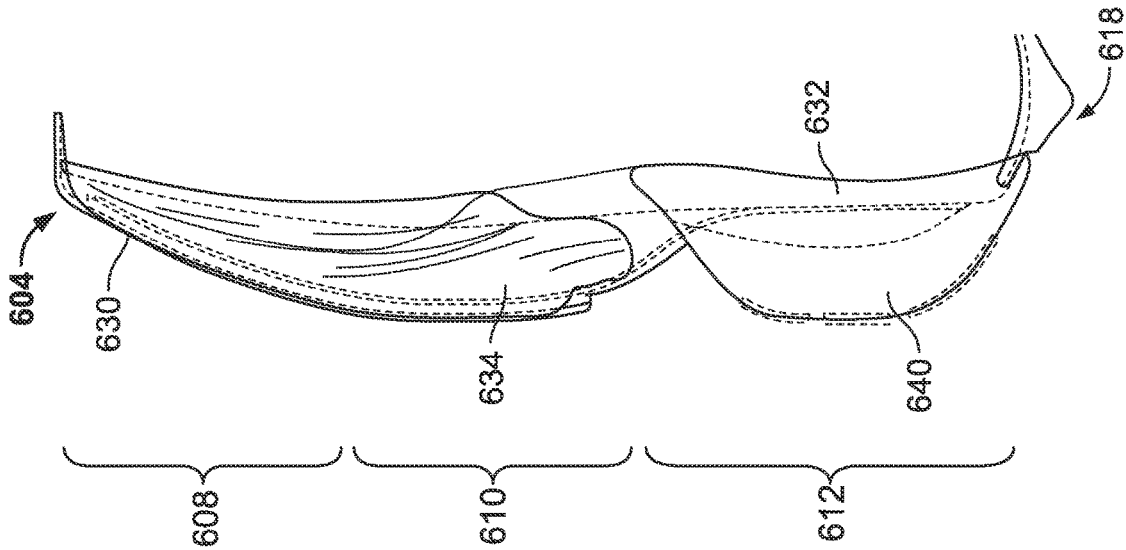

FIG. 66

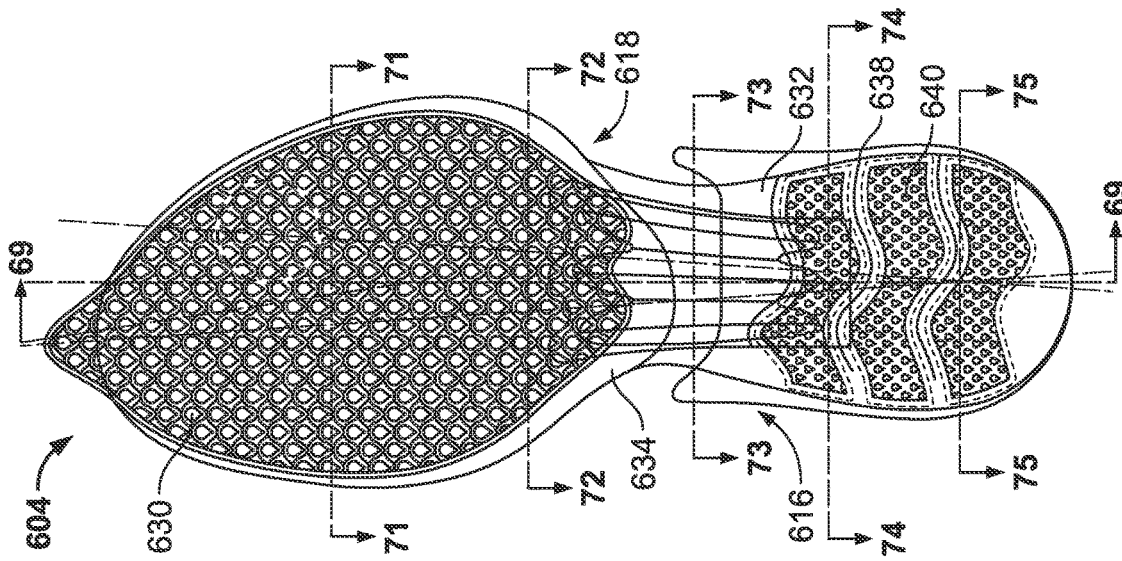

FIG. 67

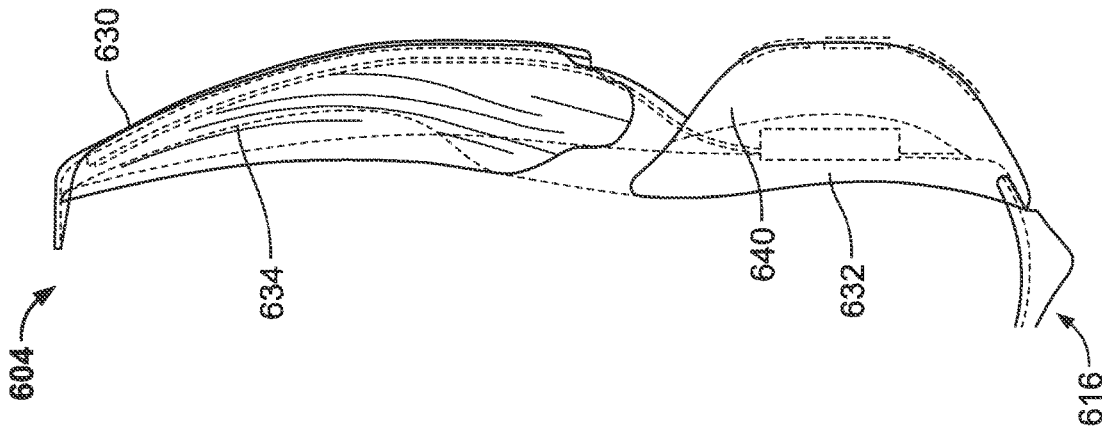
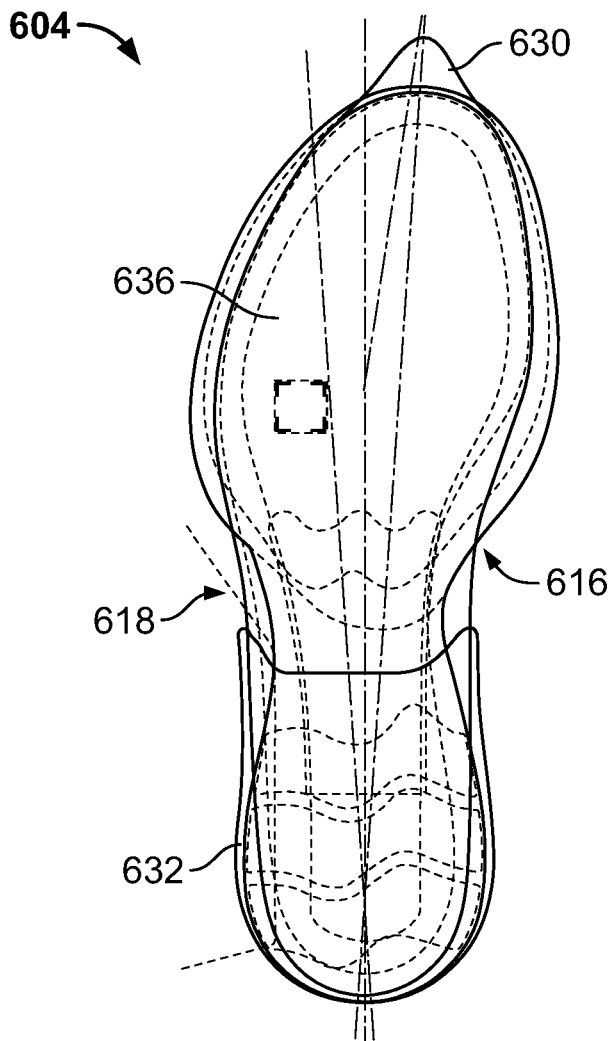
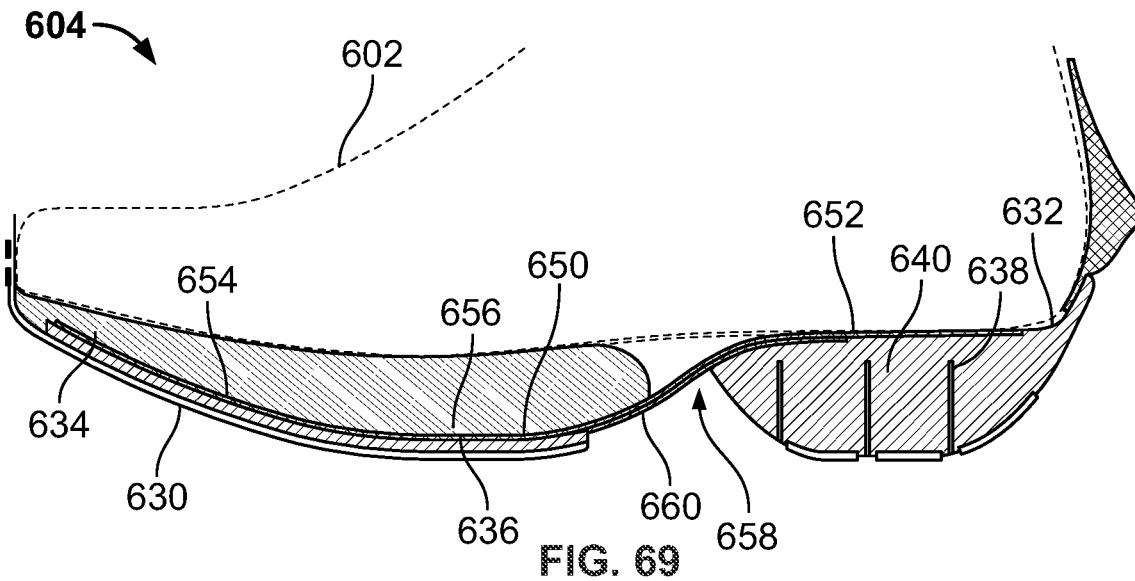

FIG. 68



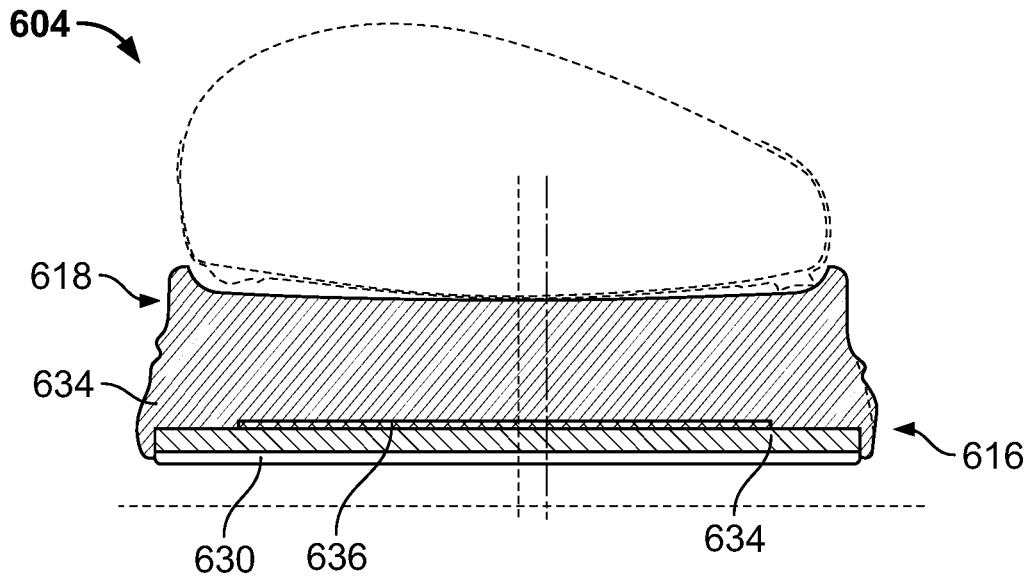

FIG. 71

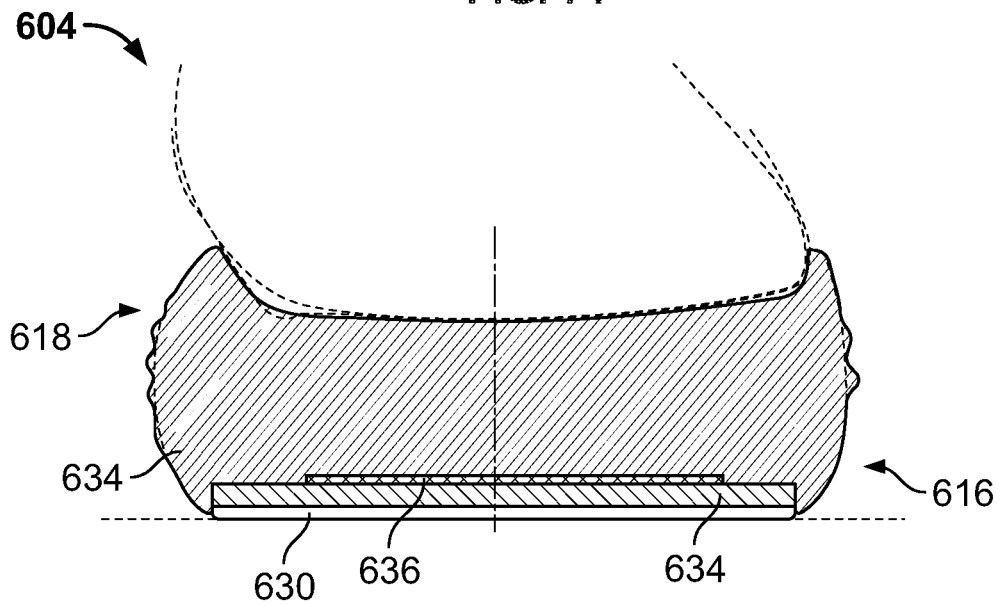

FIG. 72

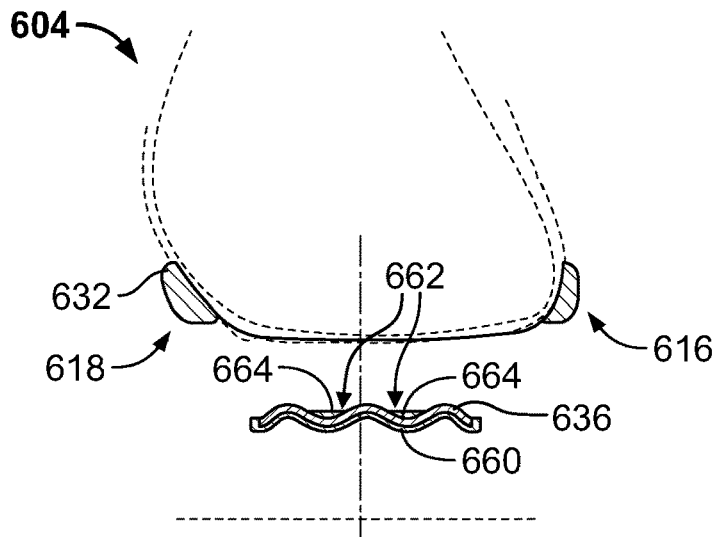

FIG. 73

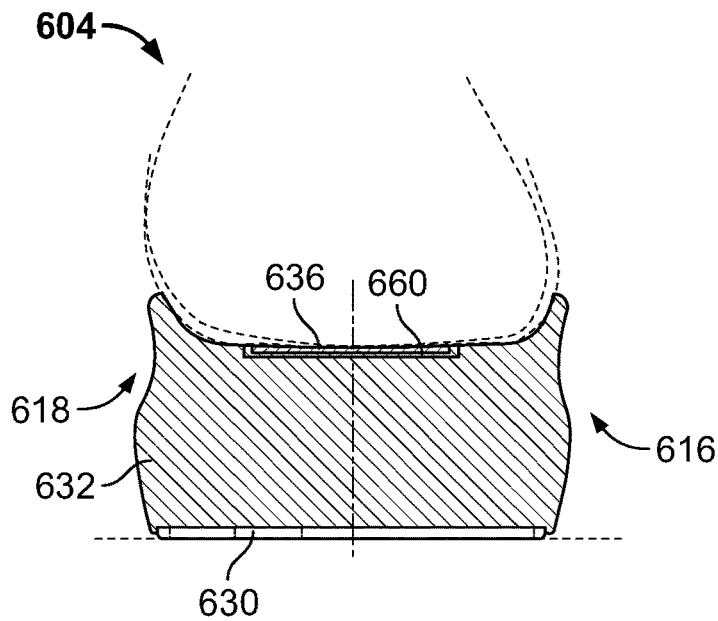

FIG. 74

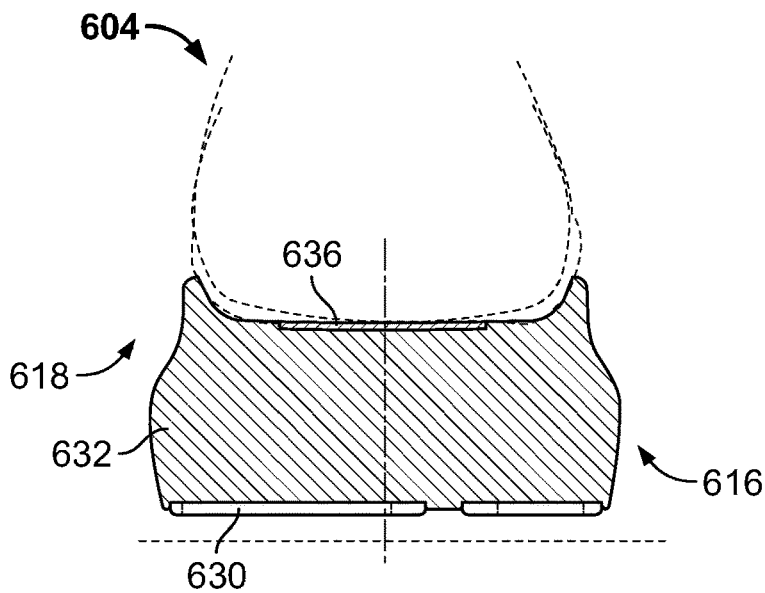
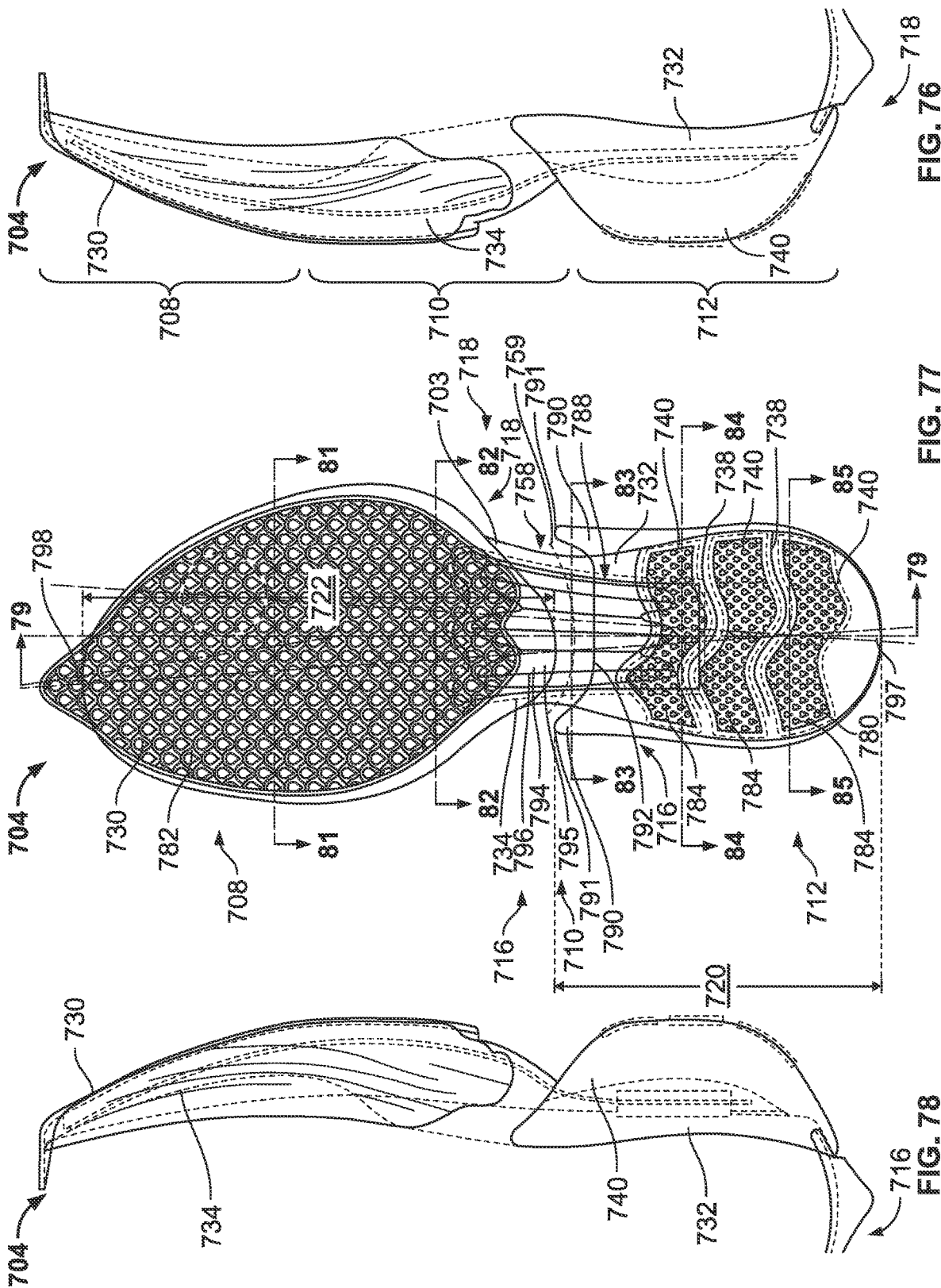

FIG. 75



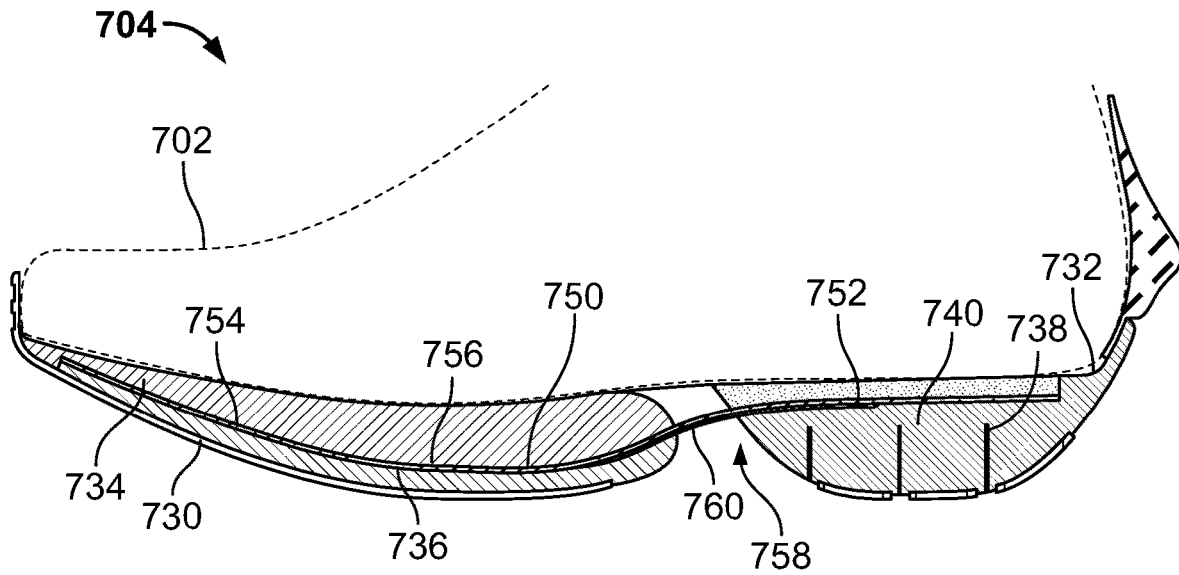

FIG. 79

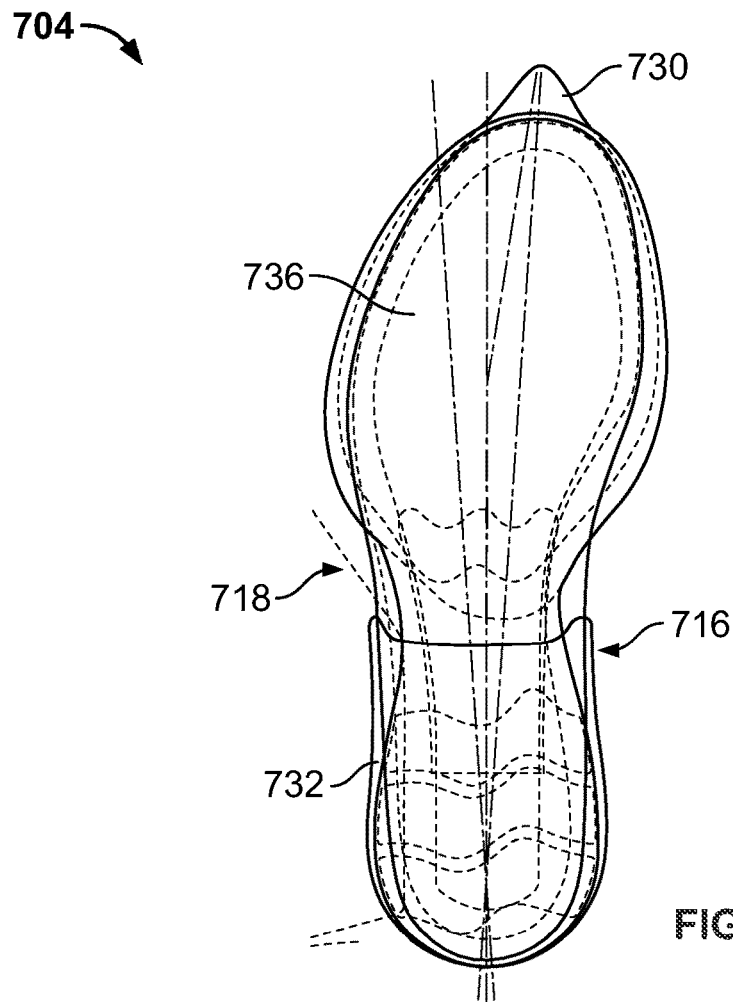

FIG. 80

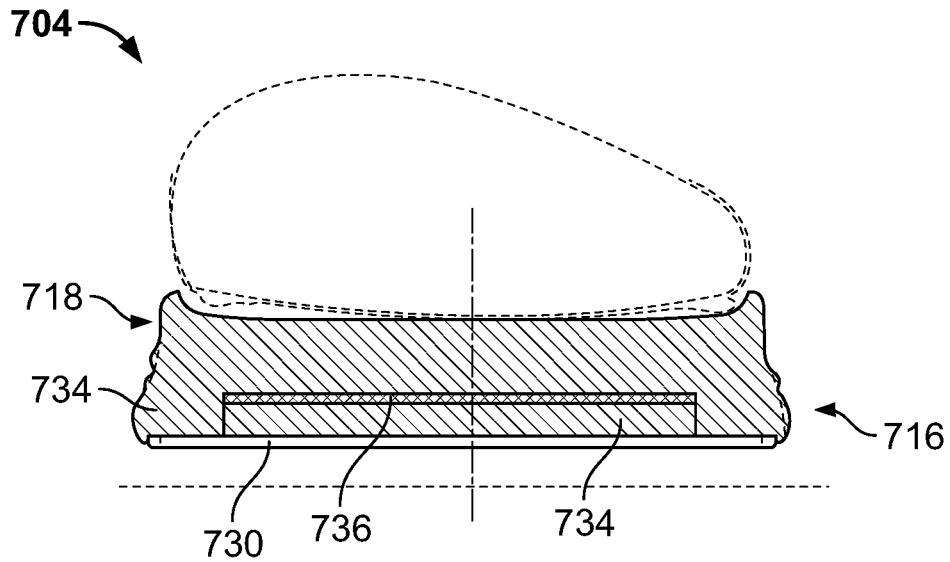

FIG. 81

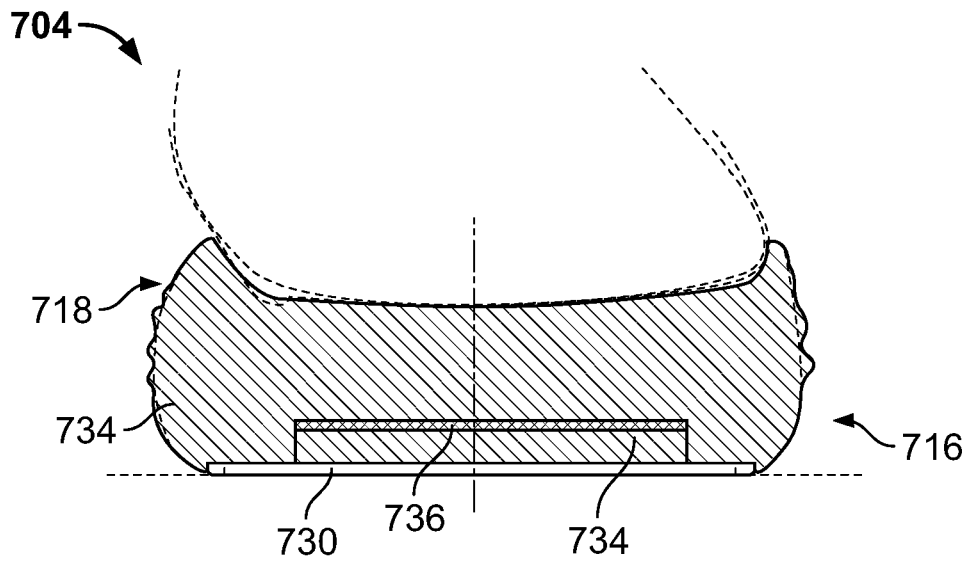

FIG. 82

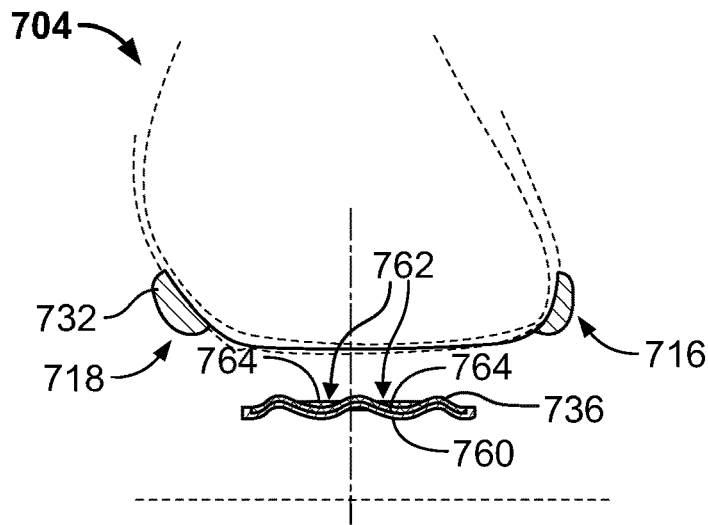

FIG. 83

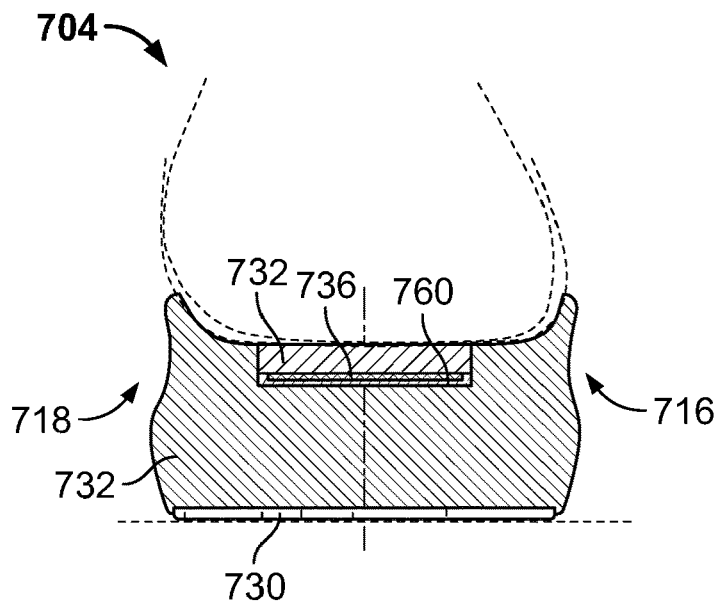

FIG. 84

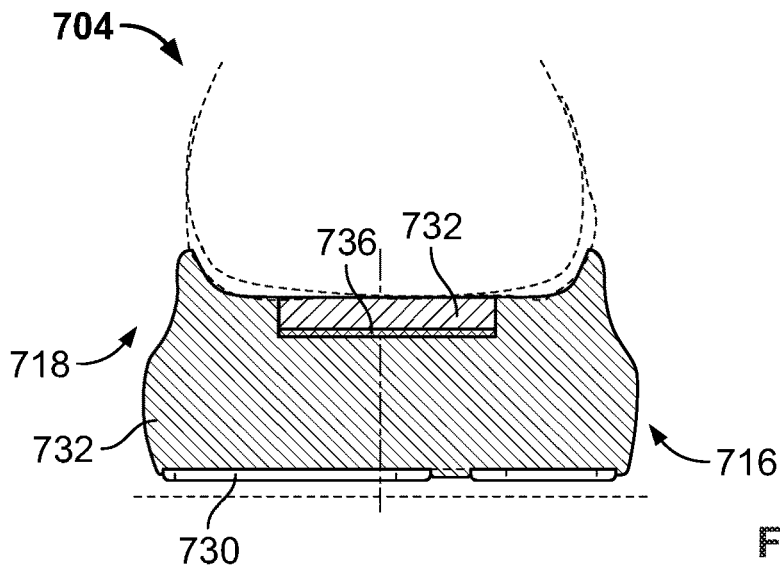

FIG. 85

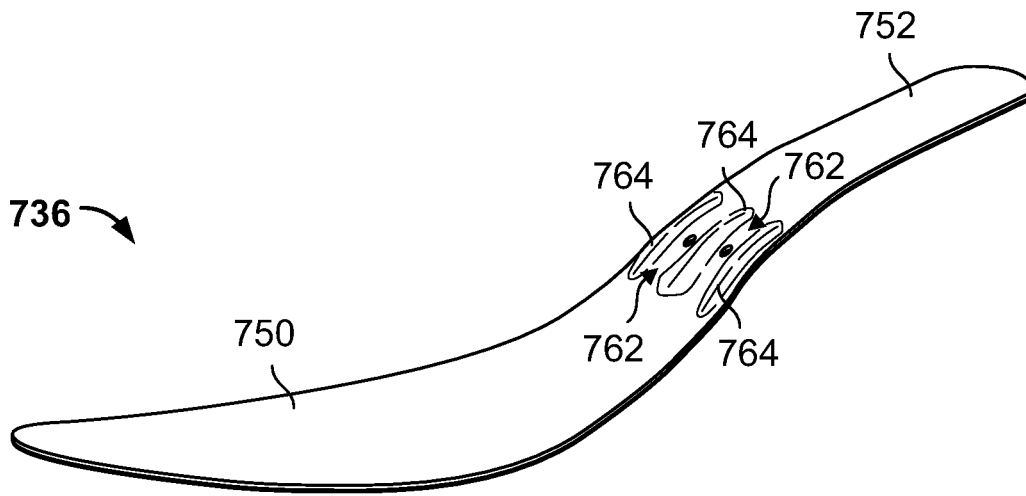

FIG. 86

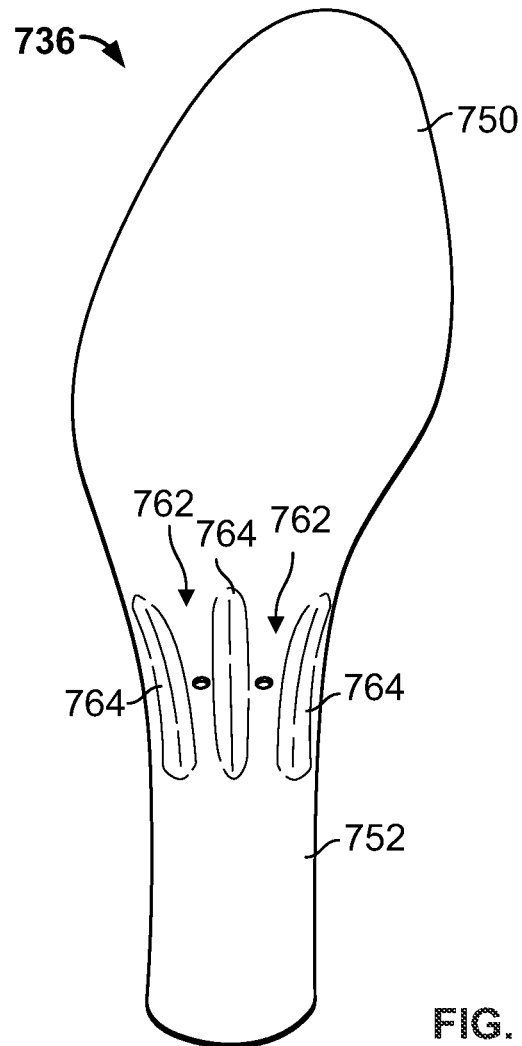

FIG. 87

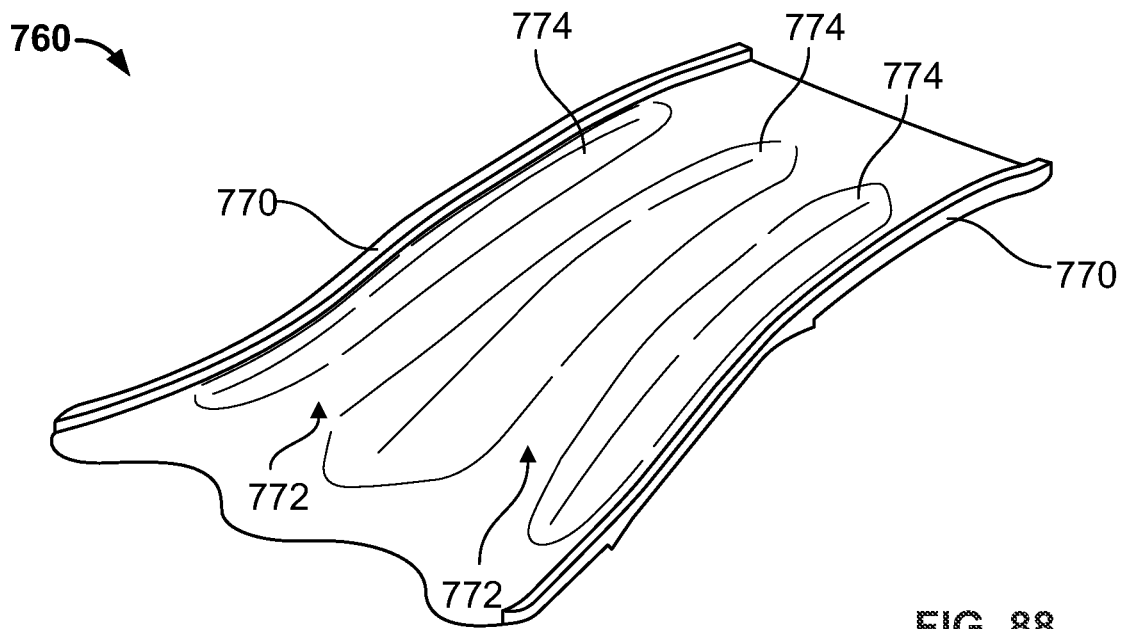

FIG. 88

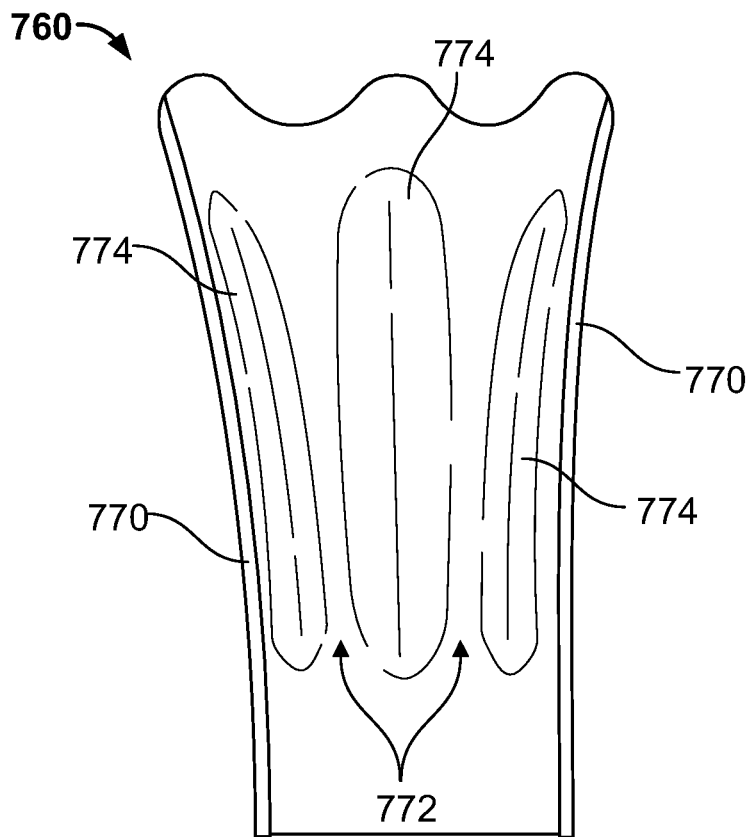

FIG. 89

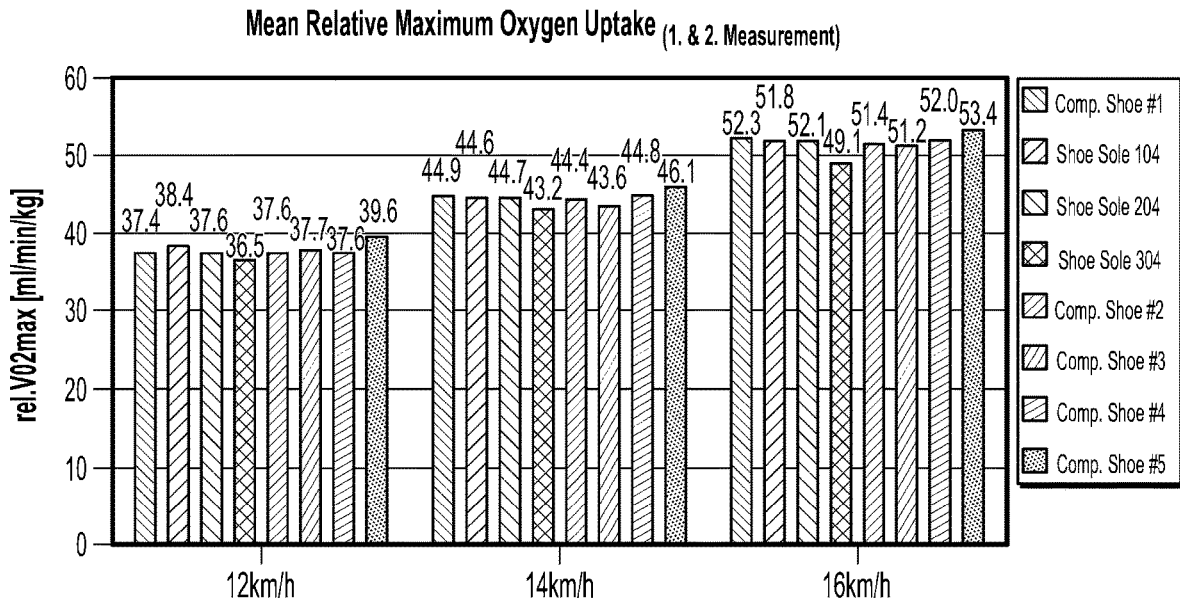

FIG. 90

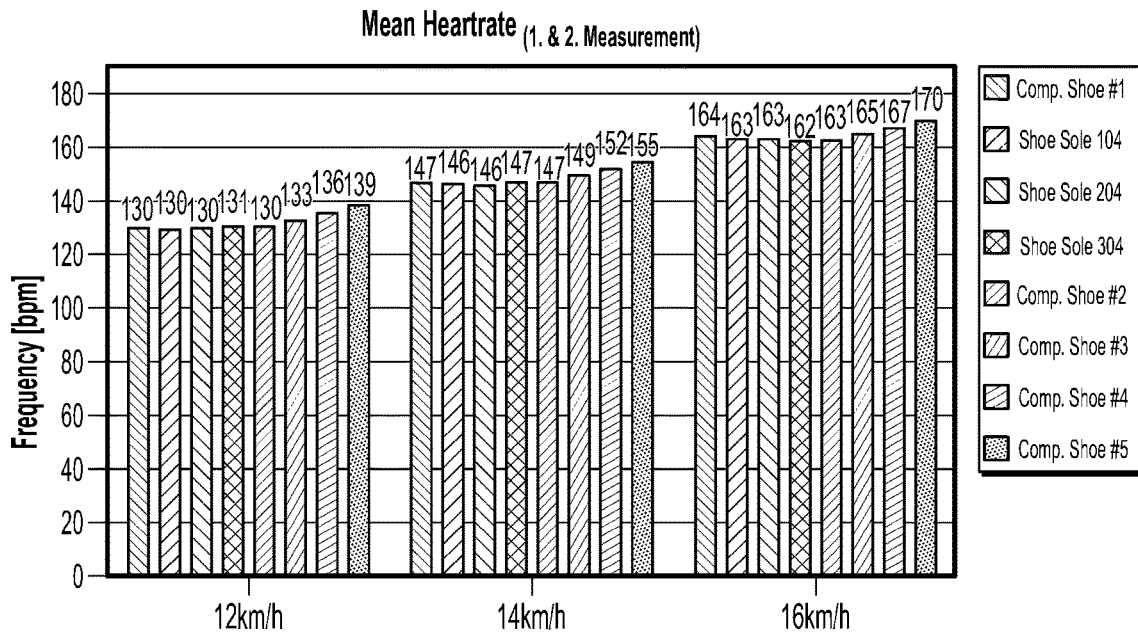

FIG. 91

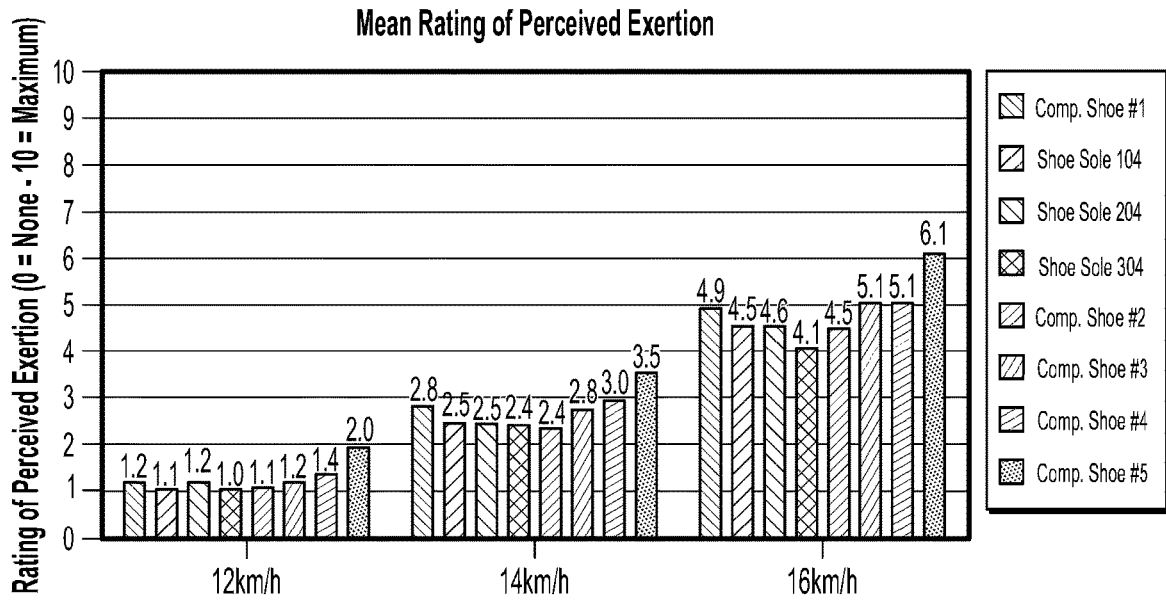

FIG. 92

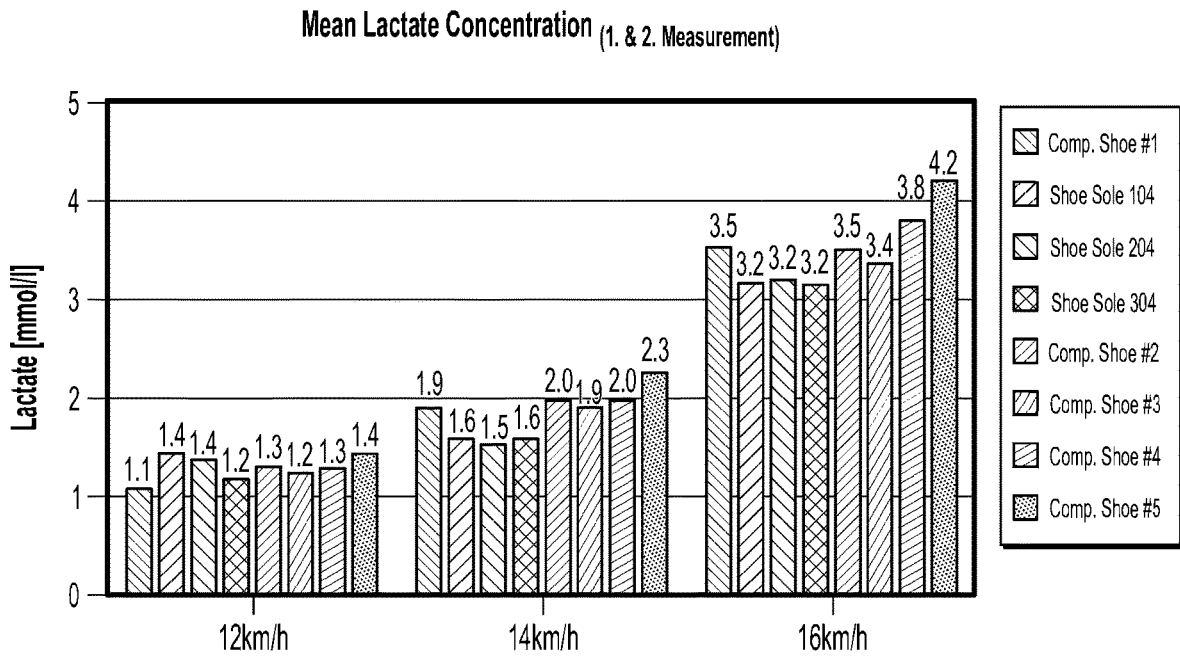

FIG. 93

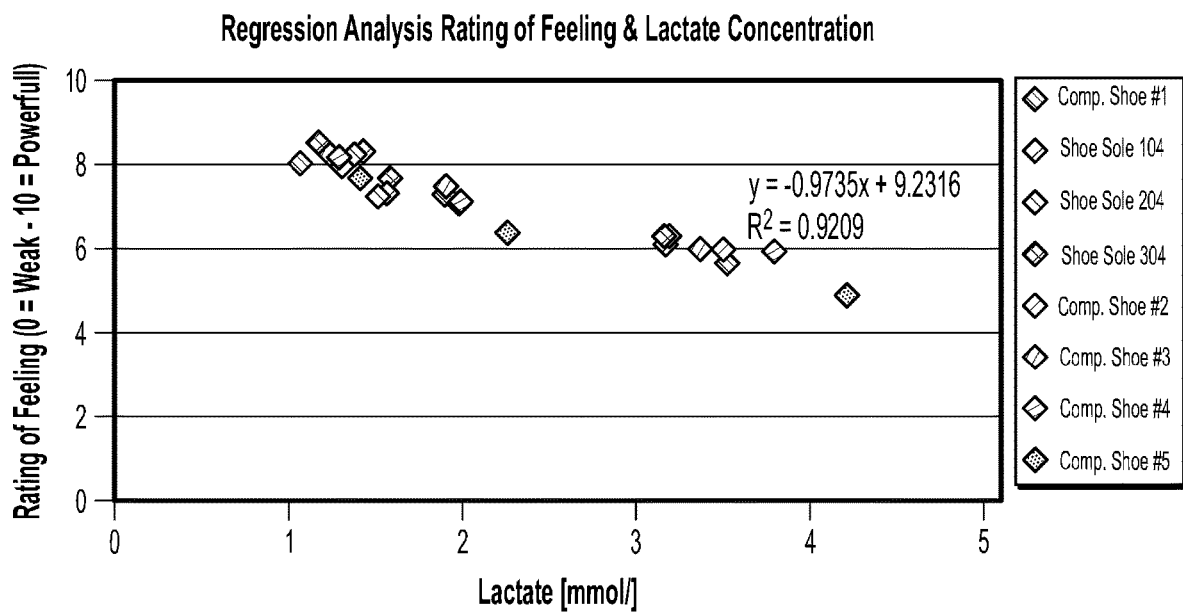

FIG. 94

US 11,974,629 B2

1

ARTICLE OF FOOTWEAR HAVING A SOLE PLATE**CROSS REFERENCE TO RELATED APPLICATIONS**

This patent application is a continuation of U.S. patent application Ser. No. 17/404,388, filed Aug. 17, 2021, which claims the benefit of U.S. Provisional Patent Application 63/067,073, filed on Aug. 18, 2020, the entire contents of which is hereby incorporated by reference, for any and all purposes.

REFERENCE REGARDING FEDERALLY SPONSORED RESEARCH OR DEVELOPMENT

Not applicable

SEQUENCE LISTING

Not applicable

BACKGROUND**1. Field of the Invention**

The present disclosure relates generally to an article of footwear including a sole plate.

2. Description of the Background

Many conventional shoes or other articles of footwear generally comprise an upper and a sole attached to a lower end of the upper. Conventional shoes further include an internal space, i.e., a void or cavity, which is created by interior surfaces of the upper and sole, that receives a foot of a user before securing the shoe to the foot. The sole attaches to a lower surface or boundary of the upper and positions itself between the upper and the ground. As a result, the sole typically provides stability and cushioning to the user when the shoe is being worn. In some instances, the sole may include multiple components, such as an outsole, a midsole, and an insole. The outsole may provide traction to a bottom surface of the sole, and the midsole may be attached to an inner surface of the outsole, and may provide cushioning or added stability to the sole. For example, a sole may include a particular foam material that may increase stability at one or more desired locations along the sole, or a foam material that may reduce stress or impact energy on the foot or leg when a user is running, walking, or engaged in another activity. The sole may also include additional components, such as plates, embedded with the sole to increase the overall stiffness of the sole and reduce energy loss during use.

The upper generally extends upward from the sole and defines an interior cavity that completely or partially encases a foot. In most cases, the upper extends over the instep and toe regions of the foot, and across medial and lateral sides thereof. Many articles of footwear may also include a tongue that extends across the instep region to bridge a gap between edges of medial and lateral sides of the upper, which define an opening into the cavity. The tongue may also be disposed below a lacing system and between medial and lateral sides of the upper, to allow for adjustment of shoe tightness. The tongue may further be manipulable by a user to permit entry or exit of a foot from the internal space or cavity. In addition, the lacing system may allow a user to adjust certain dimen-

2

sions of the upper or the sole, thereby allowing the upper to accommodate a wide variety of foot types having varying sizes and shapes.

The upper of many shoes may comprise a wide variety of materials, which may be utilized to form the upper and chosen for use based on one or more intended uses of the shoe. The upper may also include portions comprising varying materials specific to a particular area of the upper. For example, added stability may be desirable at a front of the upper or adjacent a heel region so as to provide a higher degree of resistance or rigidity. In contrast, other portions of a shoe may include a soft woven textile to provide an area with stretch-resistance, flexibility, air-permeability, or moisture-wicking properties.

However, in many cases, articles of footwear having uppers with an increased comfort and better fit are desired, along with soles having improved cushioning systems or structural characteristics such as a sole plate to add rigidity or spring-like properties.

SUMMARY

An article of footwear, as described herein, may have various configurations. The article of footwear may have an upper and a sole structure connected to the upper.

According to one aspect, the present disclosure provides a sole structure for an article of footwear. The sole structure can include a first cushioning member positioned in a heel region of the sole structure and a second cushioning member positioned in a forefoot region of the sole structure. A gap can extend between the first cushioning member and the second cushioning member in a midfoot region of the sole structure and at least one of the first cushioning member or the second cushioning member can be a supercritical foam with pockets of nitrogen gas therein. That is, the first cushioning member can be a supercritical foam with pockets of nitrogen gas therein and/or the second cushioning member can be a supercritical foam with pockets of gas therein.

In some embodiments, the article of footwear can further include an outsole defining a ground engaging surface. The outsole can include a first outsole portion coupled to the first cushioning member and a second outsole portion coupled to the second cushioning member so that the ground engaging surface is not continuous along the midfoot region. In some cases, the first outsole portion can include a first heel outsole portion and a second heel outsole portion that are spaced apart from one another. A groove can extend between the first heel outsole portion and the second heel outsole portion.

In some embodiments, the gap can extend along a non-linear path between a lateral side of the sole structure and a medial side of the sole structure. In some cases, the non-linear path can be a generally U-shaped path.

In some embodiments, the first cushioning member can include an anterior protrusion that extends toward the second cushioning member and the second cushioning member can include a posterior protrusion that extends toward the first cushioning member. The anterior protrusion and the posterior protrusion can terminate within the midfoot region of the sole structure. In some cases, a distal end (i.e., a toe end) of the anterior protrusion can be disposed closer to a toe end of the sole structure than is a distal end (i.e., a heel end) of the posterior protrusion.

In some embodiments, the first cushioning member can include a distal end at least partially in a midfoot region of the sole structure. In some embodiments, the second cushioning member can include a distal end at least partially in the midfoot region. In some cases, the first cushioning

US 11,974,629 B2

3

member and the second cushioning member can overlap in the midfoot region of the sole structure, such that at least a portion of the distal end of the first cushioning member extends past at least a portion of the distal end of the second cushioning member.

In some embodiments, the supercritical fluid can be nitrogen. The super critical foam can be formed by pressurizing a mixture of the supercritical fluid (i.e., supercritical nitrogen) and a molten material of the cushioning member and then releasing the pressure to convert the supercritical fluid to a gas. The pressure can then be released to convert the supercritical fluid to a gas, which can cause the material to expand and foam, thereby forming the pockets of nitrogen gas therein.

According to another aspect, the present disclosure provides a sole structure for an article of footwear. The sole structure can include a midsole and an outsole. The midsole can include a first cushioning member and a second cushioning member. The first cushioning member can be decoupled from the second cushioning member to define a gap therebetween. The gap can extend from a lateral side of the midsole to a medial side of the midsole. The first cushioning member can extend at least partially through a midfoot region and can include a distal end that is U-shaped. The second cushioning member can extend at least partially through the midfoot region and can include a rounded distal end. At least one of the first cushioning member or the second cushioning member can be a supercritical foam with pockets of nitrogen gas therein.

In some embodiments, a bottom surface of the upper can be exposed along the gap between the first cushioning member and the second cushioning member. The first cushioning member can define a notch and the second cushioning member can define protrusion that can extend into the notch while maintaining the gap between the first cushioning member and the second cushioning member.

In some embodiments, the first cushioning member can define a first flex region and a second flex region that are separated by flex groove. In some cases, a first outsole portion can include a first outsole element that is coupled to the first flex region and a second outsole element that is coupled to the second flex region.

In some embodiments, the rounded distal end of the second cushioning member can extend into the U-shaped distal end of the first cushioning member, such that the U-shaped distal end of the first cushioning member wraps around the rounded distal end of the second cushioning member.

In some embodiments, the sole structure can further include an outsole that can define a ground engaging surface. The outsole can include a first outsole portion coupled to the first cushioning member and a second outsole portion coupled to the second cushioning member so that the ground engaging surface is not continuous along a midfoot region of the sole structure.

In some embodiments, the supercritical fluid can be nitrogen. The super critical foam can be formed by pressurizing a mixture of the supercritical fluid (i.e., supercritical nitrogen) and a molten material of the cushioning member and then releasing the pressure to convert the supercritical fluid to a gas. The pressure can then be released to convert the supercritical fluid to a gas, which can cause the material to expand and foam, thereby forming the pockets of nitrogen gas therein.

According to yet another aspect, the present disclosure provides a sole structure for an article of footwear. The sole structure can include an outsole defining a ground-engaging

4

surface, a first cushioning member, and a second cushioning member. The first cushioning member can be disposed between the outsole and the upper in a heel region of the sole structure and can include an anterior protrusion that extends into a midfoot region of the sole structure. The second cushioning member can be disposed between the outsole and the upper in a forefoot region of the sole structure and can include a posterior protrusion that extends into the midfoot region of sole structure. A toe end of the anterior protrusion can extend past a heel end of the posterior protrusion in a longitudinal direction so that the toe end of the anterior protrusion is positioned closer to the forefoot region than is the heel end of the posterior protrusion. A gap can extend between the first cushioning member and the second cushioning member from a lateral side of the sole structure to a medial side of the sole structure and least one of the first cushioning member or the second cushioning member can be a supercritical foam with pockets of nitrogen gas therein.

In some embodiments, the second cushioning member can include a longitudinal length defined by a length from a forefoot end of the second cushioning member to the heel end of the posterior protrusion, and the first cushioning member can include a longitudinal length defined by a length from the toe end of the anterior protrusion to a heel end of the first cushioning member. The longitudinal length of the second cushioning member can be greater than the longitudinal length of the first cushioning member.

In some embodiments, the posterior protrusion can be positioned along a medial half of the sole structure.

In some embodiments, the supercritical fluid can be nitrogen. The super critical foam can be formed by pressurizing a mixture of the supercritical fluid (i.e., supercritical nitrogen) and a molten material of the cushioning member and then releasing the pressure to convert the supercritical fluid to a gas. The pressure can then be released to convert the supercritical fluid to a gas, which can cause the material to expand and foam, thereby forming the pockets of nitrogen gas therein.

Other aspects of the article of footwear, including features and advantages thereof, will become apparent to one of ordinary skill in the art upon examination of the figures and detailed description herein. Therefore, all such aspects of the article of footwear are intended to be included in the detailed description and this summary.

BRIEF DESCRIPTION OF THE DRAWINGS

FIG. 1 is a lateral side view of an article of footwear configured as a left shoe that includes an upper and a sole structure, according to an embodiment of the disclosure;

FIG. 2 is a top, lateral side view of the sole structure of the article of footwear of FIG. 1, the sole structure having a sole plate;

FIG. 3 is a lateral side view of the sole structure of FIG. 2;

FIG. 4 is a bottom view of the sole structure of FIG. 2; FIG. 5 is a medial side view of the sole structure of FIG. 2;

FIG. 6 is a cross-sectional view of the sole structure of FIG. 4 taken along line 6-6 thereof;

FIG. 7 is a top view of the sole structure of FIG. 2;

FIG. 8 is a cross-sectional view of the sole structure of FIG. 4 taken along line 8-8 thereof;

FIG. 9 is a cross-sectional view of the sole structure of FIG. 4 taken along line 9-9 thereof;

FIG. 10 is a cross-sectional view of the sole structure of FIG. 4 taken along line 10-10 thereof;

US 11,974,629 B2

5

FIG. 11 is a cross-sectional view of the sole structure of FIG. 4 taken along line 11-11 thereof;

FIG. 12 is a cross-sectional view of the sole structure of FIG. 4 taken along line 12-12 thereof;

FIG. 13 is an isometric view of the sole plate of the sole structure of FIG. 2;

FIG. 14 is a lateral side view of an article of footwear configured as a left shoe that includes an upper and a sole structure, according to another embodiment of the disclosure;

FIG. 15 is a top, lateral side view of the sole structure of the article of footwear of FIG. 14, the sole structure having a sole plate;

FIG. 16 is a lateral side view of the sole structure of FIG. 15;

FIG. 17 is a bottom view of the sole structure of FIG. 15;

FIG. 18 is a medial side view of the sole structure of FIG. 15;

FIG. 19 is a cross-sectional view of the sole structure of FIG. 17 taken along line 19-19 thereof;

FIG. 20 is a top view of the sole structure of FIG. 15;

FIG. 21 is a cross-sectional view of the sole structure of FIG. 17 taken along line 21-21 thereof;

FIG. 22 is a cross-sectional view of the sole structure of FIG. 17 taken along line 22-22 thereof;

FIG. 23 is a cross-sectional view of the sole structure of FIG. 17 taken along line 23-23 thereof;

FIG. 24 is a cross-sectional view of the sole structure of FIG. 17 taken along line 24-24 thereof;

FIG. 25 is a cross-sectional view of the sole structure of FIG. 17 taken along line 25-25 thereof;

FIG. 26 is an isometric view of the sole plate of the sole structure of FIG. 15;

FIG. 27 is a side view of the sole plate of FIG. 26;

FIG. 28 is a top view of the sole plate of FIG. 26;

FIG. 29 is a lateral side view of an article of footwear configured as a left shoe that includes an upper and a sole structure, according to yet another embodiment of the disclosure;

FIG. 30 is a top, lateral side view of the sole structure of the article of footwear of FIG. 29, the sole structure having a sole plate;

FIG. 31 is a lateral side view of the sole structure of FIG. 30;

FIG. 32 is a bottom view of the sole structure of FIG. 30;

FIG. 33 is a medial side view of the sole structure of FIG. 30;

FIG. 34 is a cross-sectional view of the sole structure of FIG. 32 taken along line 34-34 thereof;

FIG. 35 is a top view of the sole structure of FIG. 30;

FIG. 36 is a cross-sectional view of the sole structure of FIG. 32 taken along line 36-36 thereof;

FIG. 37 is a cross-sectional view of the sole structure of FIG. 32 taken along line 37-37 thereof;

FIG. 38 is a cross-sectional view of the sole structure of FIG. 32 taken along line 38-38 thereof;

FIG. 39 is a cross-sectional view of the sole structure of FIG. 32 taken along line 39-39 thereof;

FIG. 40 is a cross-sectional view of the sole structure of FIG. 32 taken along line 40-40 thereof;

FIG. 41 is an isometric view of the sole plate of the sole structure of FIG. 30;

FIG. 42 is a side view of the sole plate of FIG. 41;

FIG. 43 is a top view of the sole plate of FIG. 41;

6

FIG. 44 is a lateral side view of an article of footwear configured as a left shoe that includes an upper and a sole structure, according to another embodiment of the disclosure;

FIG. 45 is a top, lateral side view of the sole structure of the article of footwear of FIG. 44, the sole structure having a sole plate;

FIG. 46 is a lateral side view of the sole structure of FIG. 45;

FIG. 47 is a bottom view of the sole structure of FIG. 45;

FIG. 48 is a medial side view of the sole structure of FIG. 45;

FIG. 49 is a cross-sectional view of the sole structure of FIG. 47 taken along line 49-49 thereof;

FIG. 50 is a top view of the sole structure of FIG. 45;

FIG. 51 is a cross-sectional view of the sole structure of FIG. 47 taken along line 51-51 thereof;

FIG. 52 is a cross-sectional view of the sole structure of FIG. 47 taken along line 52-52 thereof;

FIG. 53 is a cross-sectional view of the sole structure of FIG. 47 taken along line 53-53 thereof;

FIG. 54 is a cross-sectional view of the sole structure of FIG. 47 taken along line 54-54 thereof;

FIG. 55 is a cross-sectional view of the sole structure of FIG. 47 taken along line 55-55 thereof;

FIG. 56 is a lateral side view of an article of footwear configured as a left shoe that includes a sole structure, according to yet another embodiment of the disclosure;

FIG. 57 is a bottom view of the sole structure of FIG. 56;

FIG. 58 is a medial side view of the sole structure of FIG. 56;

FIG. 59 is a cross-sectional view of the sole structure of FIG. 57 taken along line 59-59 thereof;

FIG. 60 is a top view of the sole structure of FIG. 56;

FIG. 61 is a cross-sectional view of the sole structure of FIG. 57 taken along line 61-61 thereof;

FIG. 62 is a cross-sectional view of the sole structure of FIG. 57 taken along line 62-62 thereof;

FIG. 63 is a cross-sectional view of the sole structure of FIG. 57 taken along line 63-63 thereof;

FIG. 64 is a cross-sectional view of the sole structure of FIG. 57 taken along line 64-64 thereof;

FIG. 65 is a cross-sectional view of the sole structure of FIG. 56 taken along line 65-65 thereof;

FIG. 66 is a lateral side view of an article of footwear configured as a left shoe that includes a sole structure, according to another embodiment of the disclosure;

FIG. 67 is a bottom view of the sole structure of FIG. 66;

FIG. 68 is a medial side view of the sole structure of FIG. 66;

FIG. 69 is a cross-sectional view of the sole structure of FIG. 67 taken along line 69-69 thereof;

FIG. 70 is a top view of the sole structure of FIG. 66;

FIG. 71 is a cross-sectional view of the sole structure of FIG. 67 taken along line 71-71 thereof;

FIG. 72 is a cross-sectional view of the sole structure of FIG. 67 taken along line 72-72 thereof;

FIG. 73 is a cross-sectional view of the sole structure of FIG. 67 taken along line 72-72 thereof;

FIG. 74 is a cross-sectional view of the sole structure of FIG. 67 taken along line 72-72 thereof;

FIG. 75 is a cross-sectional view of the sole structure of FIG. 67 taken along line 72-72 thereof;

FIG. 76 is a lateral side view of an article of footwear configured as a left shoe that includes a sole structure, according to yet another embodiment of the disclosure;

FIG. 77 is a bottom view of the sole structure of FIG. 76;

FIG. 78 is a medial side view of the sole structure of FIG. 76;

FIG. 79 is a cross-sectional view of the sole structure of FIG. 77 taken along line 79-79 thereof;

FIG. 80 is a top view of the sole structure of FIG. 76;

FIG. 81 is a cross-sectional view of the sole structure of FIG. 77 taken along line 81-81 thereof;

FIG. 82 is a cross-sectional view of the sole structure of FIG. 77 taken along line 81-81 thereof;

FIG. 83 is a cross-sectional view of the sole structure of FIG. 77 taken along line 82-82 thereof;

FIG. 84 is a cross-sectional view of the sole structure of FIG. 77 taken along line 83-83 thereof;

FIG. 85 is a cross-sectional view of the sole structure of FIG. 77 taken along line 84-84 thereof;

FIG. 86 is an isometric view of the sole plate for use with the sole structures of FIG. 56, 66, or 76;

FIG. 87 is a top plan view of the sole plate of FIG. 86;

FIG. 88 is an isometric view of another plate for use with the sole structures of FIGS. 66 and 76;

FIG. 89 is a top plan view of the plate of FIG. 88;

FIG. 90 schematically depicts a mean relative maximum oxygen uptake relative to a velocity of a runner, according to one or more aspects described herein;

FIG. 91 schematically depicts a mean heart rate relative to velocity of a runner, according to the aspects described herein;

FIG. 92 schematically depicts a mean rating of perceived exertion relative to a velocity of a runner, according to the aspects described herein;

FIG. 93 schematically depicts a mean lactate concentration relative to a velocity of a runner, according to the aspects described herein; and

FIG. 94 schematically depicts a regression analysis comparing a rate of feeling to a lactate concentration, according to the aspects described herein.

DETAILED DESCRIPTION OF THE DRAWINGS

The following discussion and accompanying figures disclose various embodiments or configurations of a shoe and a sole structure. Although embodiments of a shoe or sole structure are disclosed with reference to a sports shoe, such as a running shoe, tennis shoe, basketball shoe, etc., concepts associated with embodiments of the shoe or the sole structure may be applied to a wide range of footwear and footwear styles, including cross-training shoes, football shoes, golf shoes, hiking shoes, hiking boots, ski and snowboard boots, soccer shoes and cleats, walking shoes, and track cleats, for example. Concepts of the shoe or the sole structure may also be applied to articles of footwear that are considered non-athletic, including dress shoes, sandals, loafers, slippers, and heels. In addition to footwear, particular concepts described herein may also be applied and incorporated in other types of apparel or other athletic equipment, including helmets, padding or protective pads, shin guards, and gloves. Even further, particular concepts described herein may be incorporated in cushions, backpack straps, golf clubs, or other consumer or industrial products. Accordingly, concepts described herein may be utilized in a variety of products.

The term “about,” as used herein, refers to variation in the numerical quantity that may occur, for example, through typical measuring and manufacturing procedures used for articles of footwear or other articles of manufacture that may include embodiments of the disclosure herein; through inadvertent error in these procedures; through differences in the

manufacture, source, or purity of the ingredients used to make the compositions or mixtures or carry out the methods; and the like. Throughout the disclosure, the terms “about” and “approximately” refer to a range of values $\pm 5\%$ of the numeric value that the term precedes.

The terms “weight percent,” “wt-%,” “percent by weight,” “% by weight,” and variations thereof, as used herein, refer to the concentration of a substance or component as the weight of that substance or component divided by the total weight, for example, of the composition or of a particular component of the composition, and multiplied by 100. It is understood that, as used herein, “percent,” “%,” and the like may be synonymous with “weight percent” and “wt-%.”

The present disclosure is directed to an article of footwear and/or specific components of the article of footwear, such as an upper and/or a sole or sole structure. The upper may comprise a knitted component, a woven textile, and/or a non-woven textile. The knitted component may be made by knitting of yarn, the woven textile by weaving of yarn, and the non-woven textile by manufacture of a unitary non-woven web. Knitted textiles include textiles formed by way of warp knitting, weft knitting, flat knitting, circular knitting, and/or other suitable knitting operations. The knit textile may have a plain knit structure, a mesh knit structure, and/or a rib knit structure, for example. Woven textiles include, but are not limited to, textiles formed by way of any of the numerous weave forms, such as plain weave, twill weave, satin weave, dobbin weave, jacquard weave, double weaves, and/or double cloth weaves, for example. Non-woven textiles include textiles made by air-laid and/or spun-laid methods, for example. The upper may comprise a variety of materials, such as a first yarn, a second yarn, and/or a third yarn, which may have varying properties or varying visual characteristics.

FIGS. 1-12 depict an exemplary embodiment of an article of footwear 100 including an upper 102 and a sole structure 104. The upper 102 is attached to the sole structure 104 and together define an interior cavity into which a foot may be inserted. For reference, the article of footwear 100 defines a forefoot region 108, a midfoot region 110, and a heel region 112. The forefoot region 108 generally corresponds with portions of the article of footwear 100 that encase portions of the foot that includes the toes, the ball of the foot, and joints connecting the metatarsals with the toes or phalanges. The midfoot region 110 is proximate and adjoining the forefoot region 108, and generally corresponds with portions of the article of footwear 100 that encase the arch of foot, along with the bridge of the foot. The heel region 112 is proximate and adjoining the midfoot region 110 and generally corresponds with portions of the article of footwear 100 that encase rear portions of the foot, including the heel or calcaneus bone, the ankle, and/or the Achilles tendon.

Many conventional footwear uppers are formed from multiple elements (e.g., textiles, polymer foam, polymer sheets, leather, and synthetic leather) that are joined through bonding or stitching at a seam. In some embodiments, the upper 102 of the article of footwear 100 is formed from a knitted structure or knitted components. In various embodiments, a knitted component may incorporate various types of yarn that may provide different properties to an upper. For example, one area of the upper 102 may be formed from a first type of yarn that imparts a first set of properties, and another area of the upper 102 may be formed from a second type of yarn that imparts a second set of properties. Using this configuration, properties of the upper 102 may vary

throughout the upper **102** by selecting specific yarns for different areas of the upper **102**.

The article of footwear **100** also includes a medial side **116** (e.g., see FIG. 3) and a lateral side **118** (e.g., see FIG. 5). In particular, the lateral side **118** corresponds to an outside portion of the article of footwear **100** and the medial side **116** corresponds to an inside portion of the article of footwear **100**. As such, left and right articles of footwear have opposing lateral and medial sides, such that the medial sides **116** are closest to one another when a user is wearing the articles of footwear **100**, while the lateral sides **118** are defined as the sides that are farthest from one another while being worn. The medial side **116** and the lateral side **118** adjoin one another at opposing, distal ends of the article of footwear **100**.

Unless otherwise specified, the forefoot region **108**, the midfoot region **110**, the heel region **112**, the medial side **116**, and the lateral side **118** are intended to define boundaries or areas of the article of footwear **100**. To that end, the forefoot region **108**, the midfoot region **110**, the heel region **112**, the medial side **116**, and the lateral side **118** generally characterize sections of the article of footwear **100**. Further, both the upper **102** and the sole structure **104** may be characterized as having portions within the forefoot region **108**, the midfoot region **110**, the heel region **112**, and on the medial side **116** and the lateral side **118**. Therefore, the upper **102** and the sole structure **104**, and/or individual portions of the upper **102** and the sole structure **104**, may include portions thereof that are disposed within the forefoot region **108**, the midfoot region **110**, the heel region **112**, and on the medial side **116** and the lateral side **118**.

The sole structure **104** is connected or secured to the upper **102** and extends between a foot of a user and the ground when the article of footwear **100** is worn by the user. The sole structure **104** may include one or more components, which may include an outsole, a midsole, a heel, a vamp, and/or an insole. For example, in some embodiments, a sole structure may include an outsole that provides structural integrity to the sole structure, along with providing traction for a user, a midsole that provides a cushioning system, and an insole that provides support for an arch of a user. As will be further discussed herein, the sole structure **104** of the present embodiment of the invention includes one or more components that provide the sole structure **104** with preferable spring and damping properties.

The sole structure **104** includes an outsole **130**, a first cushioning member **132**, a second cushioning member **134**, and a sole plate **136** (see FIG. 6). The outsole **130** may define a bottom end or surface of the sole structure **104** across the heel region **112**, the midfoot region **110**, and the forefoot region **108**. Further, the outsole **130** may be a ground-engaging portion or include a ground-engaging surface of the sole structure **104** and may be opposite of the insole thereof. The outsole **130** may be formed from one or more materials to impart durability, wear-resistance, abrasion resistance, or traction to the sole structure **104**. In some embodiments, the outsole **130** may be formed from rubber, for example.

The first cushioning member **132** may be positioned adjacent to and on top of the outsole **130** in the heel region **112**, and positioned adjacent to and on top of the second cushioning member **134** in the midfoot region **110** and forefoot region **108**. The first cushioning member **132** may include one or more longitudinal grooves or flex lines **138** that extend between the medial side **116** and the lateral side **118**, which segments the first cushioning member **132** in the heel region **112**. For example, in the particular embodiment

shown in FIGS. 1-12, the first cushioning member **132** includes five flex lines **138**, which define four flex regions **140**. Further, as best shown in FIG. 4, the flex lines **138** may have a sinusoidal shape between the medial side **116** and the lateral side **118**.

The second cushioning member **134** may be positioned adjacent to and on top of the outsole **130** in the midfoot region **110** and forefoot region **108**. As will be further discussed herein, the second cushioning member **134** may also be positioned between or be enclosed within the sole plate **136** in the midfoot region **110** and/or the forefoot region **108** (see FIG. 6).

The first cushioning member **132** and/or the second cushioning member **134** may be individually constructed from a thermoplastic material, such as polyurethane (PU), for example, and/or an ethylene-vinyl acetate (EVA), copolymers thereof, or a similar type of material. In other embodiments, the first cushioning member **132** and/or the second cushioning member **134** may be an EVA-Solid-Sponge ("ESS") material, an EVA foam (e.g., PUMA® ProFoam Lite™, IGNITE Foam), polyurethane, polyether, an olefin block copolymer, a thermoplastic material (e.g., a thermoplastic polyurethane, a thermoplastic elastomer, a thermoplastic polyolefin, etc.), or a supercritical foam. The first cushioning member **132** and/or the second cushioning member **134** may be a single polymeric material or may be a blend of materials, such as an EVA copolymer, a thermoplastic polyurethane, a polyether block amide (PEBA) copolymer, and/or an olefin block copolymer. One example of a PEBA material is PEBAX®.

In embodiments where the first cushioning member **132** and/or the second cushioning member **134** is formed from a supercritical foaming process, the supercritical foam may comprise micropore foams or particle foams, such as a TPU, EVA, PEBAX®, or mixtures thereof, manufactured using a process that is performed within an autoclave, an injection molding apparatus, or any sufficiently heated/pressurized container that can process the mixing of a supercritical fluid (e.g., CO₂, N₂, or mixtures thereof) with a material (e.g., TPU, EVA, polyolefin elastomer, or mixtures thereof) that is preferably molten. During an exemplary process, a solution of supercritical fluid and molten material is pumped into a pressurized container, after which the pressure within the container is released, such that the molecules of the supercritical fluid rapidly convert to gas to form small pockets within the material and cause the material to expand into a foam, which may be used as the first cushioning member **132** and, more preferably, the second cushioning member **134**. In further embodiments, the first cushioning member **132** and/or the second cushioning member **134** may be formed using alternative methods known in the art, including the use of an expansion press, an injection machine, a pellet expansion process, a cold foaming process, a compression molding technique, die cutting, or any combination thereof. For example, the first cushioning member **132** and/or the second cushioning member **134** may be formed using a process that involves an initial foaming step in which supercritical gas is used to foam a material and then compression molded or die cut to a particular shape.

The sole structure **104** further includes the sole plate **136**, which as best shown in FIG. 13, includes an upper flange **150** and a lower flange **152** and an arched, curved, or C-shaped rear portion **154** that connects the upper flange **150** and the lower flange **152**. Further, a gap **156** extends between the upper flange **150** and the lower flange **152**, into which the second cushioning member **134** may be positioned, as previously discussed herein. As shown in FIG. 6,

US 11,974,629 B2

11

the sole plate 136 extends at least partially through the midfoot region 110 and at least partially through the forefoot region 108. As further illustrated in FIG. 6, the rear portion 154 of the sole plate 136 may be spaced from a rear side of the second cushioning member 134, which creates a spacing 158 therebetween.

With continued reference to FIG. 6, the lower flange 152 may be adjacent to and positioned between the outsole 130 and the second cushioning member 134, and the upper flange 150 may be adjacent to and positioned between the second cushioning member 134 and the first cushioning member 132. In some embodiments, the sole plate 136 has a uniform thickness. For example, in particular embodiments, the thickness is approximately 1.2 centimeters.

In some embodiments, the sole plate 136 comprises a PU plastic, such as a thermoplastic polyurethane (TPU) material, for example. Other thermoplastic elastomers consisting of block copolymers are also possible. In other embodiments, the sole plate 136 can include carbon fiber, for example.

In some embodiments, the outsole 130 or the ground-engaging surface is not continuous along the article of footwear 100. For example, as best shown in FIG. 6, there is a spacing 158, or an absence of a ground-engaging surface, along the article of footwear 100, which is located within the midfoot region 110 of the article of footwear 100.

FIGS. 14-25 show another configuration of an article of footwear 200. Similar to the sole structure 104, the sole structure 204 is configured to be attached to an upper 202 and together define an interior cavity into which a foot may be inserted. For reference, the sole structure 204 defines a forefoot region 208, a midfoot region 210, and a heel region 212. The forefoot region 208 generally corresponds with portions of an article of footwear, such as the article of footwear 200, for example, that encase portions of the foot that include the toes, the ball of the foot, and joints connecting the metatarsals with the toes or phalanges. The midfoot region 210 is proximate and adjoining the forefoot region 208, and generally corresponds with portions of the article of footwear that encase the arch of a foot, along with the bridge of a foot. The heel region 212 is proximate and adjoining the midfoot region 210 and generally corresponds with portions of the article of footwear that encase rear portions of the foot, including the heel or calcaneus bone, the ankle, and/or the Achilles tendon.

The article of footwear 200 also includes a medial side 216 (e.g., see FIG. 18) and a lateral side 218 (e.g., see FIG. 16). In particular, the lateral side 218 corresponds to an outside portion of the article of footwear 200 and the medial side 216 corresponds to an inside portion of the article of footwear 200. As such, left and right articles of footwear have opposing lateral and medial sides, such that the medial sides 216 are closest to one another when a user is wearing the articles of footwear 200, while the lateral sides 218 are defined as the sides that are farthest from one another while being worn. The medial side 216 and the lateral side 218 adjoin one another at opposing, distal ends of the article of footwear 200.

Unless otherwise specified, the forefoot region 208, the midfoot region 210, the heel region 212, the medial side 216, and the lateral side 218 are intended to define boundaries or areas of the article of footwear 200. To that end, the forefoot region 208, the midfoot region 210, the heel region 212, the medial side 216, and the lateral side 218 generally characterize sections of the article of footwear 200. Further, both the upper 202 and the sole structure 204 may be characterized as having portions within the forefoot region 208, the

12

midfoot region 210, the heel region 212, and on the medial side 216 and the lateral side 218. Therefore, the upper 202 and the sole structure 204, and/or individual portions of the upper 202 and the sole structure 204, may include portions thereof that are disposed within the forefoot region 208, the midfoot region 210, the heel region 212, and on the medial side 216 and the lateral side 218.

The sole structure 204 is connected or secured to the upper 202 and extends between a foot of a user and the ground when the article of footwear 200 is worn by the user. The sole structure 204 may include one or more components, which may include an outsole, a midsole, a heel, a vamp, and/or an insole. For example, in some embodiments, a sole structure may include an outsole that provides structural integrity to the sole structure, along with providing traction for a user, a midsole that provides a cushioning system, and an insole that provides support for an arch of a user. As will be further discussed herein, the sole structure 204 of the present embodiment of the invention includes one or more components that provide the sole structure 204 with preferable spring and damping properties.

The sole structure 204 includes an outsole 230, a first cushioning member 232, a second cushioning member 234, and a sole plate 236 (see FIG. 19). The outsole 230 may define a bottom end or surface of the sole structure 204 across the heel region 212, the midfoot region 210, and the forefoot region 208. Further, the outsole 230 may be a ground-engaging portion or include a ground-engaging surface of the sole structure 204 and may be opposite of the insole thereof. The outsole 230 may be formed from one or more materials to impart durability, wear-resistance, abrasion resistance, or traction to the sole structure 204. In some embodiments, the outsole 230 may be formed from rubber, for example.

The first cushioning member 232 may be positioned adjacent to and on top of the outsole 230 in the heel region 212, and positioned adjacent to and on top of the second cushioning member 234 in the midfoot region 210 and forefoot region 208. The first cushioning member 232 may include one or more longitudinal grooves or flex lines 238 that extend between the medial side 216 and the lateral side 218, which segments the first cushioning member 232 in the heel region 212. For example, in the particular embodiment shown in FIGS. 14-25, the first cushioning member 232 includes five flex lines 238, which define four flex regions 240. Further, as best shown in FIG. 17, the flex lines 238 may have a sinusoidal shape between the medial side 216 and the lateral side 218.

The second cushioning member 234 may be positioned adjacent to and on top of the outsole 230 in the midfoot region 210 and forefoot region 208. As will be further discussed herein, the second cushioning member 234 may also be positioned between or be enclosed within the sole plate 236 in the forefoot region 208 (see FIG. 19).

The first cushioning member 232 and/or the second cushioning member 234 may be individually constructed from a thermoplastic material, such as polyurethane (PU), for example, and/or an ethylene-vinyl acetate (EVA), copolymers thereof, or a similar type of material. In other embodiments, the first cushioning member 232 and/or the second cushioning member 234 may be an EVA-Solid-Sponge ("ESS") material, an EVA foam (e.g., PUMA® ProFoam Lite™, IGNITE Foam), polyurethane, polyether, an olefin block copolymer, a thermoplastic material (e.g., a thermoplastic polyurethane, a thermoplastic elastomer, a thermoplastic polyolefin, etc.), or a supercritical foam. The first cushioning member 232 and/or the second cushioning

13

member **234** may be a single polymeric material or may be a blend of materials, such as an EVA copolymer, a thermoplastic polyurethane, a polyether block amide (PEBA) copolymer, and/or an olefin block copolymer. One example of a PEBA material is PEBAX®.

In embodiments where the first cushioning member **232** and/or the second cushioning member **234** is formed from a supercritical foaming process, the supercritical foam may comprise micropore foams or particle foams, such as a TPU, EVA, PEBAX®, or mixtures thereof, manufactured using a process that is performed within an autoclave, an injection molding apparatus, or any sufficiently heated/pressurized container that can process the mixing of a supercritical fluid (e.g., CO₂, N₂, or mixtures thereof) with a material (e.g., TPU, EVA, polyolefin elastomer, or mixtures thereof) that is preferably molten. During an exemplary process, a solution of supercritical fluid and molten material is pumped into a pressurized container, after which the pressure within the container is released, such that the molecules of the supercritical fluid rapidly convert to gas to form small pockets within the material and cause the material to expand into a foam, which may be used as the first cushioning member **232** and, more preferably, the second cushioning member **234**. In further embodiments, the first cushioning member **232** and/or the second cushioning member **234** may be formed using alternative methods known in the art, including the use of an expansion press, an injection machine, a pellet expansion process, a cold foaming process, a compression molding technique, die cutting, or any combination thereof. For example, the first cushioning member **232** and/or the second cushioning member **234** may be formed using a process that involves an initial foaming step in which supercritical gas is used to foam a material and then compression molded or die cut to a particular shape.

The sole structure **204** further includes the sole plate **236**, which is best shown in FIGS. **26-28**, includes an upper flange **250** and a lower flange **252** that connect at a vertex point **254**. Further, a gap **256** extends between the upper flange **250** and the lower flange **252**, into which the second cushioning member **234** may be positioned, as previously discussed herein. As shown in FIG. **19**, the sole plate **236** extends through the forefoot region **208**. As further illustrated in FIG. **19**, the vertex point **254** may be spaced from a front side of the second cushioning member **234**, which creates a spacing or gap **258** between the upper flange **250** and the lower flange **252**.

With continued reference to FIG. **19**, a rear portion of the lower flange **252** may be adjacent to and positioned between the outsole **230** and the second cushioning member **234**, and a rear portion of the upper flange **250** may be adjacent to and positioned between the second cushioning member **234** and the first cushioning member **232**. In some embodiments, the sole plate **236** has a uniform thickness. For example, in particular embodiments, the thickness is approximately 1.2 centimeters.

With reference to FIGS. **26** and **28**, the upper flange **250** and the lower flange **252** may also include one or more cut-out portions **260**, **262**. The cut-out portions **260**, **262** may be advantageous to allow the medial and lateral sides of the sole plate **236** to flex independent of one another.

In some embodiments, the sole plate **236** comprises a PU plastic, such as a thermoplastic polyurethane (TPU) material, for example. Other thermoplastic elastomers consisting of block copolymers are also possible. In other embodiments, the sole plate **236** can include carbon fiber, for example.

14

In some embodiments, the outsole **230** or the ground-engaging surface is not continuous along the article of footwear **200**. For example, as best shown in FIG. **19**, there is a spacing **264**, or an absence of a ground-engaging surface, along the article of footwear **200**, which is located within the midfoot region **210** of the article of footwear **200**.

FIGS. **29-40** show another configuration of an article of footwear **300**. Similar to the sole structures **104**, **204**, the sole structure **304** is configured to be attached to an upper **302** and together define an interior cavity into which a foot may be inserted. For reference, the sole structure **304** defines a forefoot region **308**, a midfoot region **310**, and a heel region **312**. The forefoot region **308** generally corresponds with portions of an article of footwear, such as the article of footwear **300**, for example, that encase portions of the foot that include the toes, the ball of the foot, and joints connecting the metatarsals with the toes or phalanges. The midfoot region **310** is proximate and adjoining the forefoot region **308**, and generally corresponds with portions of the article of footwear that encase the arch of a foot, along with the bridge of a foot. The heel region **312** is proximate and adjoining the midfoot region **310** and generally corresponds with portions of the article of footwear that encase rear portions of the foot, including the heel or calcaneus bone, the ankle, and/or the Achilles tendon.

The article of footwear **300** also includes a medial side **316** (e.g., see FIG. **33**) and a lateral side **318** (e.g., see FIG. **31**). In particular, the lateral side **318** corresponds to an outside portion of the article of footwear **300** and the medial side **316** corresponds to an inside portion of the article of footwear **300**. As such, left and right articles of footwear have opposing lateral and medial sides, such that the medial sides **316** are closest to one another when a user is wearing the articles of footwear **300**, while the lateral sides **318** are defined as the sides that are farthest from one another while being worn. The medial side **316** and the lateral side **318** adjoin one another at opposing, distal ends of the article of footwear **300**.

Unless otherwise specified, the forefoot region **308**, the midfoot region **310**, the heel region **312**, the medial side **316**, and the lateral side **318** are intended to define boundaries or areas of the article of footwear **300**. To that end, the forefoot region **308**, the midfoot region **310**, the heel region **312**, the medial side **316**, and the lateral side **318** generally characterize sections of the article of footwear **300**. Further, both the upper **302** and the sole structure **304** may be characterized as having portions within the forefoot region **308**, the midfoot region **310**, the heel region **312**, and on the medial side **316** and the lateral side **318**. Therefore, the upper **302** and the sole structure **304**, and/or individual portions of the upper **302** and the sole structure **304**, may include portions thereof that are disposed within the forefoot region **308**, the midfoot region **310**, the heel region **312**, and on the medial side **316** and the lateral side **318**.

The sole structure **304** is connected or secured to the upper **302** and extends between a foot of a user and the ground when the article of footwear **300** is worn by the user. The sole structure **304** may include one or more components, which may include an outsole, a midsole, a heel, a vamp, and/or an insole. For example, in some embodiments, a sole structure may include an outsole that provides structural integrity to the sole structure, along with providing traction for a user, a midsole that provides a cushioning system, and an insole that provides support for an arch of a user. As will be further discussed herein, the sole structure **304** of the present embodiment of the invention includes one

or more components that provide the sole structure 304 with preferable spring and damping properties.

The sole structure 304 includes an outsole 330, a first cushioning member 332, a second cushioning member 334, and a sole plate 336 (see FIG. 34). The outsole 330 may define a bottom end or surface of the sole structure 304 across the heel region 312, the midfoot region 310, and the forefoot region 308. Further, the outsole 330 may be a ground-engaging portion or include a ground-engaging surface of the sole structure 304 and may be opposite of the insole thereof. The outsole 330 may be formed from one or more materials to impart durability, wear-resistance, abrasion resistance, or traction to the sole structure 304. In some embodiments, the outsole 330 may be formed from rubber, for example.

The first cushioning member 332 may be positioned adjacent to and on top of the outsole 330 in the heel region 312. The first cushioning member 332 may also be positioned adjacent to and below the sole plate 336. The first cushioning member 332 may include one or more longitudinal grooves or flex lines 338 that extend between the medial side 316 and the lateral side 318, which segments the first cushioning member 332 in the heel region 312. For example, in the particular embodiment shown in FIGS. 29-40, the first cushioning member 332 includes five flex lines 338, which define four flex regions 340. Further, as best shown in FIG. 32, the flex lines 338 may have a sinusoidal shape between the medial side 316 and the lateral side 318.

The second cushioning member 334 may be positioned adjacent to and on top of the outsole 330 in the midfoot region 310 and forefoot region 308. As will be further discussed herein, the sole plate 336 may also bifurcate the second cushioning member 334, such that the sole plate 336 is positioned within the second cushioning member 334 (see FIG. 34).

The first cushioning member 332 and/or the second cushioning member 334 may be individually constructed from a thermoplastic material, such as polyurethane (PU), for example, and/or an ethylene-vinyl acetate (EVA), copolymers thereof, or a similar type of material. In other embodiments, the first cushioning member 332 and/or the second cushioning member 334 may be an EVA-Solid-Sponge ("ESS") material, an EVA foam (e.g., PUMA® ProFoam Lite™, IGNITE Foam), polyurethane, polyether, an olefin block copolymer, a thermoplastic material (e.g., a thermoplastic polyurethane, a thermoplastic elastomer, a thermoplastic polyolefin, etc.), or a supercritical foam. The first cushioning member 332 and/or the second cushioning member 334 may be a single polymeric material or may be a blend of materials, such as an EVA copolymer, a thermoplastic polyurethane, a polyether block amide (PEBA) copolymer, and/or an olefin block copolymer. One example of a PEBA material is PEBAX®.

In embodiments where the first cushioning member 332 and/or the second cushioning member 334 is formed from a supercritical foaming process, the supercritical foam may comprise micropore foams or particle foams, such as a TPU, EVA, PEBAX®, or mixtures thereof, manufactured using a process that is performed within an autoclave, an injection molding apparatus, or any sufficiently heated/pressurized container that can process the mixing of a supercritical fluid (e.g., CO₂, N₂, or mixtures thereof) with a material (e.g., TPU, EVA, polyolefin elastomer, or mixtures thereof) that is preferably molten. During an exemplary process, a solution of supercritical fluid and molten material is pumped into a pressurized container, after which the pressure within the container is released, such that the molecules of the super-

critical fluid rapidly convert to gas to form small pockets within the material and cause the material to expand into a foam, which may be used as the first cushioning member 332 and, more preferably, the second cushioning member 334. In further embodiments, the first cushioning member 332 and/or the second cushioning member 334 may be formed using alternative methods known in the art, including the use of an expansion press, an injection machine, a pellet expansion process, a cold foaming process, a compression molding technique, die cutting, or any combination thereof. For example, the first cushioning member 332 and/or the second cushioning member 334 may be formed using a process that involves an initial foaming step in which supercritical gas is used to foam a material and then compression molded or die cut to a particular shape.

The sole structure 304 further includes the sole plate 336, which as best shown in FIGS. 41-43, includes a curved portion 350 and a rear portion 352, which may be relatively planar. The curved portion 350 may also include an anterior curved portion 354 and a posterior curved portion 356. The anterior curved portion 354 and the posterior curved portion 356 may each individually include one or more radii of curvature.

With reference to FIG. 34, the curved portion 350 of the plate 336 may be positioned within the second cushioning member 334 and the rear portion 352 of the plate 336 may be positioned above the first cushioning member 332. Further, a portion of the posterior curved portion 356 may extend between a gap 358 between the first cushioning member 332 and the second cushioning member 334. Resultantly, in this embodiment, a portion of the plate 336 does not include a cushioning member—such as the first cushioning member 332 or the second cushioning member 334—above, below, or between the plate 336. Thus, the plate 336 is spaced from the upper 302 and a gap, or absence of material, is present between the plate 336 and the upper 302 approximate the midfoot region 310 and/or the heel region 312 (see FIG. 29). In some embodiments, the sole plate 336 has a uniform thickness. For example, in particular embodiments, the thickness is approximately 1.2 centimeters.

In some embodiments, the sole plate 336 comprises a PU plastic, such as a thermoplastic polyurethane (TPU) material, for example. Other thermoplastic elastomers consisting of block copolymers are also possible. In other embodiments, the sole plate 336 can include carbon fiber, for example.

As briefly noted herein, in some embodiments, the outsole 330 or the ground-engaging surface is not continuous along the article of footwear 300. For example, as best shown in FIG. 34, there is a spacing or gap 358, or an absence of a ground-engaging surface, along the article of footwear 300, which is located within the midfoot region 310 of the article of footwear 300.

FIGS. 44-55 show another configuration of an article of footwear 400. Similar to the sole structures 104, 204, 304, the sole structure 404 is configured to be attached to an upper 402 and together define an interior cavity into which a foot may be inserted. Like the other sole structures, the sole structure 404 can be defined by a forefoot region 408, a midfoot region 410, a heel region 412, as well as a medial side 416 (see FIG. 48) and a lateral side 418 (see FIG. 46). Like the other embodiments described herein, unless otherwise specified, the forefoot region, the midfoot region, the heel region, the medial side 416, and the lateral side 418 are intended to define boundaries or areas of the article of footwear 400. To that end, the forefoot region, the midfoot

region, the heel region, the medial side **416**, and the lateral side **418** generally characterize sections of the article of footwear **400**. Further, both the upper **402** and the sole structure **404** may be characterized as having portions within the forefoot region **408**, the midfoot region **410**, the heel region **412**, and on the medial side **416** and the lateral side **418**. Therefore, the upper **402** and the sole structure **404**, and/or individual portions of the upper **402** and the sole structure **404**, may include portions thereof that are disposed within the forefoot region **408**, the midfoot region **410**, the heel region **412**, and on the medial side **416** and the lateral side **418**.

The sole structure **404** is connected or secured to the upper **402** and extends between a foot of a user and the ground when the article of footwear **400** is worn by the user. The sole structure **404** may include one or more components, which may include an outsole, a midsole, a heel, a vamp, and/or an insole. For example, in some embodiments, a sole structure may include an outsole that provides structural integrity to the sole structure, along with providing traction for a user, a midsole that provides a cushioning system, and an insole that provides support for an arch of a user. As will be further discussed herein, the sole structure **404** of the present embodiment of the invention includes one or more components that provide the sole structure **404** with preferable spring and damping properties.

The sole structure **404** includes an outsole **430**, a first cushioning member **432**, a second cushioning member **434**, and a sole plate **436** (see FIG. **49**). The outsole **430** may define a bottom end or surface of the sole structure **404** across the heel region **412**, the midfoot region **410**, and the forefoot region **408**. Further, the outsole **430** may be a ground-engaging portion or include a ground-engaging surface of the sole structure **404** and may be opposite of the insole thereof. The outsole **430** may be formed from one or more materials to impart durability, wear-resistance, abrasion resistance, or traction to the sole structure **404**. In some embodiments, the outsole **430** may be formed from rubber, for example.

The first cushioning member **432** may be positioned adjacent to and on top of the outsole **430** in the heel region **412**, and positioned adjacent to and on top of the second cushioning member **434** in the midfoot region **410** and forefoot region **408**. The first cushioning member **432** may include one or more longitudinal grooves or flex lines **438** that extend between the medial side **416** and the lateral side **418**, which segments the first cushioning member **432** in the heel region **412**. For example, in the particular embodiment shown in FIGS. **44-55**, the first cushioning member **432** includes five flex lines **438**, which define four flex regions **440**. Further, as best shown in FIG. **47**, the flex lines **438** may have a sinusoidal shape between the medial side **416** and the lateral side **418**.

The second cushioning member **434** may be positioned adjacent to and on top of the outsole **430** in the midfoot region **410** and forefoot region **408**. As will be further discussed herein, the second cushioning member **434** may also be positioned between or be enclosed within the sole plate **436** in the forefoot region **408** (see FIG. **49**).

The first cushioning member **432** and/or the second cushioning member **434** may be individually constructed from a thermoplastic material, such as polyurethane (PU), for example, and/or an ethylene-vinyl acetate (EVA), copolymers thereof, or a similar type of material. In other embodiments, the first cushioning member **432** and/or the second cushioning member **434** may be an EVA-Solid-Sponge ("ESS") material, an EVA foam (e.g., PUMA®

ProFoam Lite™, IGNITE Foam), polyurethane, polyether, an olefin block copolymer, a thermoplastic material (e.g., a thermoplastic polyurethane, a thermoplastic elastomer, a thermoplastic polyolefin, etc.), or a supercritical foam. The first cushioning member **432** and/or the second cushioning member **434** may be a single polymeric material or may be a blend of materials, such as an EVA copolymer, a thermoplastic polyurethane, a polyether block amide (PEBA) copolymer, and/or an olefin block copolymer. One example of a PEBA material is PEBAX®.

In embodiments where the first cushioning member **432** and/or the second cushioning member **434** is formed from a supercritical foaming process, the supercritical foam may comprise micropore foams or particle foams, such as a TPU, EVA, PEBAX®, or mixtures thereof, manufactured using a process that is performed within an autoclave, an injection molding apparatus, or any sufficiently heated/pressurized container that can process the mixing of a supercritical fluid (e.g., CO₂, N₂, or mixtures thereof) with a material (e.g., TPU, EVA, polyolefin elastomer, or mixtures thereof) that is preferably molten. During an exemplary process, a solution of supercritical fluid and molten material is pumped into a pressurized container, after which the pressure within the container is released, such that the molecules of the supercritical fluid rapidly convert to gas to form small pockets within the material and cause the material to expand into a foam, which may be used as the first cushioning member **432** and, more preferably, the second cushioning member **434**. In further embodiments, the first cushioning member **432** and/or the second cushioning member **434** may be formed using alternative methods known in the art, including the use of an expansion press, an injection machine, a pellet expansion process, a cold foaming process, a compression molding technique, die cutting, or any combination thereof. For example, the first cushioning member **432** and/or the second cushioning member **434** may be formed using a process that involves an initial foaming step in which supercritical gas is used to foam a material and then compression molded or die cut to a particular shape.

The sole structure **404** further includes the sole plate **436**, which as best shown in FIGS. **49** and **50**, is a relatively planar structure having a first cut-out portion **450** near a front end thereof and a second cut-out portion **452** near a rear end thereof.

With particular reference to FIG. **49**, the plate **436** may be positioned above the first cushioning member **432** in the midfoot region **410**. In some embodiments, the sole plate **436** has a uniform thickness. For example, in particular embodiments, the thickness is approximately 1.8 centimeters.

In some embodiments, the sole plate **436** comprises a PU plastic, such as a thermoplastic polyurethane (TPU) material, for example. Other thermoplastic elastomers consisting of block copolymers are also possible. In other embodiments, the sole plate **436** can include carbon fiber, for example.

As briefly noted herein, in some embodiments, the outsole **430** or the ground-engaging surface is not continuous along the article of footwear **400**. For example, as best shown in FIG. **49**, there is a spacing or gap **458**, or an absence of a ground-engaging surface, along the article of footwear **400**, which is located within the midfoot region **410** of the article of footwear **400**.

FIGS. **56-65** show another configuration of an article of footwear **500** having an upper **502** and a sole structure **504**. Similar to the sole structures **104**, **204**, **304**, **404**, the sole structure **504** is configured to be attached to the upper **502**

and together define an interior cavity into which a foot may be inserted. Also similar to the other sole structures, the sole structure **504** includes a forefoot region **508**, a midfoot region **510**, a heel region **512**, a medial side **516** (see FIG. **58**) and a lateral side **518** (see FIG. **56**). Unless otherwise specified, the forefoot region **508**, the midfoot region **510**, the heel region **512**, the medial side **516**, and the lateral side **518** are intended to define boundaries or areas of the article of footwear **500**. Further, as will be further discussed herein, the sole structure **504** of the present embodiment of the invention includes one or more components that provide the sole structure **504** with preferable spring and damping properties.

The sole structure **504** also includes an outsole **530**, a first cushioning member **532**, a second cushioning member **534**, and a sole plate **536** (see FIG. **59**). The first cushioning member **532** may be positioned adjacent to and on top of the outsole **530** in the heel region **512**. The first cushioning member **532** may also be positioned adjacent to and below the sole plate **536**. The first cushioning member **532** may include one or more longitudinal grooves or flex lines **538** that extend between the medial side **516** and the lateral side **518**, which segments the first cushioning member **532** in the heel region **512**.

The second cushioning member **534** may be positioned adjacent to and on top of the outsole **530** in the midfoot region **510** and forefoot region **508**. As will be further discussed herein, the sole plate **536** may also extend between the second cushioning member **534** and the outsole **530** (see FIG. **59**). The first cushioning member **532** and/or the second cushioning member **534** may be individually constructed from a thermoplastic material, such as polyurethane (PU), for example, and/or an ethylene-vinyl acetate (EVA), copolymers thereof, or a similar type of material. In other embodiments, the first cushioning member **532** and/or the second cushioning member **534** may be an EVA-Solid-Sponge ("ESS") material, an EVA foam (e.g., PUMA® ProFoam Lite™, IGNITE Foam), polyurethane, polyether, an olefin block copolymer, a thermoplastic material (e.g., a thermoplastic polyurethane, a thermoplastic elastomer, a thermoplastic polyolefin, etc.), or a supercritical foam. The first cushioning member **532** and/or the second cushioning member **534** may be a single polymeric material or may be a blend of materials, such as an EVA copolymer, a thermoplastic polyurethane, a polyether block amide (PEBA) copolymer, and/or an olefin block copolymer. One example of a PEBA material is PEBAX®.

The sole structure **504** further includes the sole plate **536**, which as best shown in FIG. **59**, includes a curved portion **550** and a rear portion **552**, which may be relatively planar. The curved portion **550** may also include an anterior curved portion **554** and a posterior curved portion **556**. The anterior curved portion **554** and the posterior curved portion **556** may each individually include one or more radii of curvature.

With reference to FIG. **59**, the curved portion **550** of the sole plate **536** may be positioned below the second cushioning member **534** and the rear portion **552** of the sole plate **536** may be positioned above the first cushioning member **532**. Further, a portion of the posterior curved portion **556** may extend between a gap **558** between the first cushioning member **532** and the second cushioning member **534**. In some embodiments, the sole plate **536** has a uniform thickness. For example, in particular embodiments, the thickness is approximately 1.2 centimeters. In some embodiments, the sole plate **536** comprises a PU plastic, such as a thermoplastic polyurethane (TPU) material, for example. Other thermoplastic elastomers consisting of block copolymers are

also possible. In other embodiments, the sole plate **536** can include carbon fiber, for example.

As briefly noted herein, in some embodiments, the outsole **530** or the ground-engaging surface is not continuous along the article of footwear **500**. For example, as best shown in FIG. **59**, there is a spacing or gap **558**, or an absence of a ground-engaging surface, along the article of footwear **500**, which is located within the midfoot region **510** and/or the heel region **512** of the article of footwear **500**. In this embodiment, similar to the plate **336**, a portion of the plate **536** does not include a cushioning member—such as the first cushioning member **532** or the second cushioning member **534**—above, below, or between the plate **536**. Thus, the plate **536** is spaced from the upper **502** and a gap, or absence of material, is present between the plate **536** and the upper **502** approximate the midfoot region **510** and/or the heel region **512** (see FIG. **59**).

In some embodiments, the sole structure **504** may also include a second plate **560**. In the particular embodiment shown in FIGS. **56-65**, the second plate **560** encases the sole plate **536** such that the sole plate **536** sits within the second plate **560**. Additionally, as best shown in FIG. **59**, the second plate **560** extends across the forefoot region **508**, the midfoot region **510**, and the heel region **512**. Thus, the second plate **560** is positioned below the sole plate **536** across an entire length thereof. In other embodiments, as will be further discussed herein, the second plate **560** may only extend across a portion of the sole plate **536** and may be positioned at a location along the sole structure **504** where the sole plate **536** needs targeted structural support. The second plate **560** may be constructed from similar materials to the sole plate **536**, which have already been discussed herein. However, in particular embodiments, the material used to construct the second plate **560** may also differ from the material used to construct the sole plate **536** such that the second plate **560** provides added reinforcement to the sole plate **536**. For example, in one embodiment, the sole plate **536** may be constructed from a carbon fiber material and the second plate **560** may be constructed from thermoplastic polyurethane (TPU) to support the sole plate **536**. Additionally, the second plate **560** may support the structural integrity of the sole plate **536** and prevent the sole plate **536** from fracturing during use thereof.

In addition to the second plate **560**, an amount of material may be injected into one or more grooves of the sole plate **536**. More particularly, in this embodiment, the sole plate **536** may include two grooves **562** (see FIG. **63**) and a material **564** may be injected or positioned within the grooves **562**. Similar to the second plate **560**, the material injected into the grooves **562** may provide further structural support to the sole plate **536** and targeted support to the sole plate **536**. For example, in this particular embodiment, the grooves are provided across the midfoot or arch region of the sole structure **504**, and therefore, the material **564** may provide support to the sole plate **536** in the arch region thereof, which thereby provides further support to a user's foot in the arch region of the sole structure **504**. The injected material **564** may be a suitable plastic material, such as thermoplastic polyurethane (TPU) or the like.

FIGS. **66-75** show another configuration of an article of footwear **600** having an upper **602** and a sole structure **604**. Similar to the sole structures **104**, **204**, **304**, **404**, **504** the sole structure **604** is configured to be attached to the upper **602** and together define an interior cavity into which a foot may be inserted. The sole structure **604**, similar to the other sole structures, includes a forefoot region **608**, a midfoot region **610**, a heel region **612**, a medial side **616** (see FIG. **68**) and

US 11,974,629 B2

21

a lateral side **618** (see FIG. **66**). Unless otherwise specified, the forefoot region **608**, the midfoot region **610**, the heel region **612**, the medial side **616**, and the lateral side **618** are intended to define boundaries or areas of the article of footwear **600**.

The sole structure **604** also includes an outsole **630**, a first cushioning member **632**, a second cushioning member **634**, and a sole plate **636** (see FIG. **69**). The outsole **630** may define a bottom end or surface of the sole structure **604** across the heel region **612**, the midfoot region **610**, and the forefoot region **608**.

The first cushioning member **632** may be positioned adjacent to and on top of the outsole **630** in the heel region **612**. The first cushioning member **632** may also be positioned adjacent to and below the sole plate **636**. The first cushioning member **632** may include one or more longitudinal grooves or flex lines **638** that extend between the medial side **616** and the lateral side **618**, which segments the first cushioning member **632** in the heel region **612**.

The second cushioning member **634** may be positioned adjacent to and on top of the outsole **630** in the midfoot region **610** and forefoot region **608**. As will be further discussed herein, the sole plate **636** may also bifurcate the second cushioning member **634**, such that the sole plate **636** is positioned within the second cushioning member **634** (see FIG. **69**).

The first cushioning member **632** and/or the second cushioning member **634** may be individually constructed from similar materials to those already disclosed in connection with the other embodiments disclosed herein.

The sole structure **604** further includes the sole plate **636**, which as best shown in FIGS. **69**, includes a curved portion **650** and a rear portion **652**, which may be relatively planar. The curved portion **650** may also include an anterior curved portion **654** and a posterior curved portion **656**. The anterior curved portion **654** and the posterior curved portion **656** may each individually include one or more radii of curvature.

With reference to FIG. **69**, the curved portion **650** of the plate **636** may be positioned within the second cushioning member **634** and the rear portion **652** of the plate **636** may be positioned above the first cushioning member **632**. Further, a portion of the posterior curved portion **656** may extend between a gap **658** between the first cushioning member **632** and the second cushioning member **634**. In some embodiments, the sole plate **636** has a uniform thickness. For example, in particular embodiments, the thickness is approximately 1.2 centimeters.

In some embodiments, the sole plate **636** comprises a PU plastic, such as a thermoplastic polyurethane (TPU) material, for example. Other thermoplastic elastomers consisting of block copolymers are also possible. In other embodiments, the sole plate **636** can include carbon fiber, for example.

As briefly noted herein, in some embodiments, the outsole **630** or the ground-engaging surface is not continuous along the article of footwear **600**. For example, as best shown in FIG. **69**, there is a spacing or gap **658**, or an absence of a ground-engaging surface, along the article of footwear **600**, which is located within the midfoot region **610** of the article of footwear **600**.

Similar to the sole structure **504**, the sole structure **604** may also include a second plate **660**. In the particular embodiment shown in FIGS. **66-75**, the second plate **660** partially encases the sole plate **636** such that the sole plate **636** sits within the second plate **660**. Additionally, as best shown in FIG. **69**, the second plate **660** extends across the midfoot region **610** and the heel region **610**. Thus, the

22

second plate **660** is positioned below the sole plate **636** across a portion of the sole plate **636**, and more particularly, the arch or midfoot region thereof. In other embodiments, as previously discussed herein, the second plate **660** may extend across an entire length of the sole plate **636** or may be positioned at a location along the sole structure **604** where the sole plate **636** needs targeted structural support. The second plate **660** may be constructed from similar materials to the sole plate **636**, which have already been discussed herein. However, in particular embodiments, the material used to construct the second plate **660** may differ from the material used to construct the sole plate **636** such that the second plate **660** provides added reinforcement to the sole plate **636**. For example, in one embodiment, the sole plate **636** may be constructed from a carbon fiber material and the second plate **660** may be constructed from thermoplastic polyurethane (TPU) to support the sole plate **636**. Additionally, the second plate **660** may support the structural integrity of the sole plate **636** and prevent the sole plate **636** from fracturing during use thereof.

In addition to the second plate **660**, an amount of material may be injected into one or more grooves of the sole plate **636**. More particularly, in this embodiment, the sole plate **636** may include two grooves **662** (see FIG. **73**) and material **664** may be injected or positioned within the grooves **662**. Similar to the second plate **660**, the material injected into the grooves **662** may provide further structural support to the sole plate **636** and targeted support to the sole plate **636**. For example, in this particular embodiment, the grooves are provided across the midfoot or arch region of the sole structure **604**, and therefore, the material **664** may provide support to the sole plate **636** in the arch region thereof, which thereby provides further support to a user's foot in the arch region of the sole structure **604**. The injected material **664** may be a suitable plastic material, such as thermoplastic polyurethane (TPU) or the like.

FIGS. **76-85** show another configuration of an article of footwear **700** having an upper **702** and a sole structure **704**. Similar to the sole structures **104**, **204**, **304**, **404**, **504**, **604** the sole structure **704** is configured to be attached to the upper **702** and together define an interior cavity into which a foot may be inserted. Further, the sole structure **704** includes a forefoot region **708**, a midfoot region **710**, a heel region **712**, a medial side **716** (see FIG. **78**), and a lateral side **718** (see FIG. **76**). Unless otherwise specified, the forefoot region **708**, the midfoot region **710**, the heel region **712**, the medial side **716**, and the lateral side **718** are intended to define boundaries or areas of the article of footwear **700**.

The sole structure **704** includes an outsole **730**, a first cushioning member **732**, a second cushioning member **734**, and a sole plate **736** (see FIG. **79**). The outsole **730** may define a bottom end or surface of the sole structure **704** across the heel region **712**, the midfoot region **710**, and the forefoot region **708**.

The first cushioning member **732** may be positioned adjacent to and on top of the outsole **730** in the heel region **712**. The first cushioning member **732** may also be positioned adjacent to and below the sole plate **736**. The first cushioning member **732** may include one or more longitudinal grooves or flex lines **738** that extend between the medial side **716** and the lateral side **718**, which segments the first cushioning member **732** in the heel region **712**. As illustrated, the flex lines **738** are curvilinear lines; however, they may also be configured differently, for example to be linear or arcuate. In some cases, flex lines can also be oriented differently, for example to extend in a longitudinal,

i.e., heel-to-toe, direction. The flex lines 738 can segment the first cushioning member 732 in the heel region 712. For example, as shown in FIGS. 77 and 79, the first cushioning member 732 includes two flex lines 738, which define three flex regions 740, i.e., flex zones. Specifically, the first cushioning member 732 includes a first or toe end flex region, a second or middle flex region, and a third or heel end flex region. Further, as best shown in FIG. 77, the flex lines 738 are configured as non-linear lines with a sinusoidal shape, which extend between the medial side 716 and the lateral side 718.

The second cushioning member 734 may be positioned adjacent to and on top of the outsole 730 in the midfoot region 710 and forefoot region 708. As will be further discussed herein, the sole plate 736 may also bifurcate the second cushioning member 734, such that the sole plate 736 is positioned within the second cushioning member 734 (see FIG. 79). Further, the sole plate 736 may also bifurcate the first cushioning member 732, such that the sole plate 736 is positioned within the first cushioning member as well (see FIG. 79).

The first cushioning member 732 and/or the second cushioning member 734 may be individually constructed from similar materials to the first and second cushioning members of the other embodiments.

The sole structure 704 also includes the sole plate 736, which as best shown in FIG. 79, includes a curved portion 750 and a rear portion 752, which may be relatively planar. The curved portion 750 may also include an anterior curved portion 754 and a posterior curved portion 756. The anterior curved portion 754 and the posterior curved portion 756 may each individually include one or more radii of curvature.

With reference to FIG. 79, the curved portion 750 of the plate 736 may be positioned within the second cushioning member 734 and the rear portion 752 of the plate 736 may be positioned above the first cushioning member 732. Further, a portion of the posterior curved portion 756 may extend between a gap 758 between the first cushioning member 732 and the second cushioning member 734. In some embodiments, the sole plate 736 has a uniform thickness. For example, in particular embodiments, the thickness is approximately 1.2 centimeters.

In some embodiments, the sole plate 736 comprises a PU plastic, such as a thermoplastic polyurethane (TPU) material, for example. Other thermoplastic elastomers consisting of block copolymers are also possible. In other embodiments, the sole plate 736 can include carbon fiber, for example.

As briefly noted herein, in some embodiments, the outsole 730 or the ground-engaging surface is not continuous along the article of footwear 700. For example, as best shown in FIG. 79, there is a spacing or gap 758, or an absence of a ground-engaging surface, along the article of footwear 700, which is located within the midfoot region 710 of the article of footwear 700. Correspondingly, the outsole 730 can include a first outsole portion 780 coupled to the first cushioning member 732 and a second outsole portion 782 coupled to the second cushioning member 734. In some cases, each of the first outsole portion 780 and the second outsole portion 782 can further include one or more sub-portions. For example, as illustrated in FIG. 77, the first outsole portion includes three heel outsole portions 784, e.g., a first outsole element, a second outsole element, and a third outsole element, each coupled to one of the respective flex regions 740. Accordingly, the outsole portions 784 are separated from one another, such that the flex lines 738

extend between the respective outsole portions 784, and such that the ground engaging surface is not continuous in the heel region 712.

Further, since the first cushioning member 732 and the second cushioning member 734 are separated by the gap 758, a bottom surface 703 of the upper 702 can be exposed, such that the bottom surface 703 is visible when viewed in a direction going from the bottom surface of the sole structure 704 toward the upper 702 (see FIG. 77). Here, due to the inclusion of the sole plate 736, the bottom surface 703 is exposed along the medial side 716 and the lateral side 718 of the sole structure 704. However, the bottom surface 703 also remains exposed between the sole plate 736 and the upper 702 as a result of the gap that is maintained therebetween.

Continuing, as illustrated in FIG. 77, the gap 758 can extend along a path between the medial side 716 and the lateral side 718 of the sole structure 704. Depending on the specific shapes of the first cushioning member 732 and the second cushioning member 734, the gap 758 can follow a number of linear or non-linear paths between the first cushioning member 732 and the second cushioning member 734. For example, as illustrated in FIG. 77, the first cushioning member 732 has a U-shaped distal end 788 positioned at a toe end of the first cushioning member 732. The U-shaped distal end 788 is formed by one or more anterior protrusions 790 that extend from the distal end 788 of the first cushioning member 732 toward the second cushioning member 734 (e.g., at each of the medial side 716 and the lateral side 718). Here the first cushioning member 732 includes two anterior protrusions 790 that extend from each of the medial side 716 and the lateral side 718 of the first cushioning member 732 to define a notch 792 therebetween. The anterior protrusions 790 extend at least partially into the midfoot region 710 of the sole structure to define respective distal ends 791 that terminate within the midfoot region 710. The second cushioning member defines a rounded distal end 794 at a heel end of the second cushioning member 734, which is formed by a posterior protrusion 796 that extends toward the first cushioning member 732 and at least partially into the midfoot region 710. More specifically, the posterior protrusion 796 can extend toward the notch 792 in the midfoot region 710 and along a medial half of the sole structure 704. As a result, the gap 758 extends along a non-linear path 759 that is substantially U-shaped.

In some cases, the posterior protrusion 796 can extend past at least one of the anterior protrusions 790 to extend into the notch 792, such that the U-shaped distal end 788 of the first cushioning member 732 wraps at least partially around the distal end 794 of the second cushioning member 734 (i.e., a distal end of the posterior protrusion 796). Consequently, one or both of the anterior protrusions 790 can extend past the posterior protrusion 796 in the midfoot region 710 so that a distal end 791 (i.e., a toe end) of at least one of the anterior protrusions 790 is disposed closer to a toe end of the sole structure 704 than is a distal end 795 (i.e., a heel end) of the posterior protrusion 796. Put another way, the first cushioning member 732 can extend past the second cushioning member 734 in a longitudinal direction so that a portion of the first cushioning member 732 (e.g., the distal end 788) is closer to the toe end of the sole structure 704 than is a portion of the second cushioning member 734 (e.g., the distal end 794).

Additionally, each of the first cushioning member 732 and the second cushioning member 734 can define a respective longitudinal length between a forefoot end (i.e., a toe end) and a heel end. More specifically, as illustrated in FIG. 77,

US 11,974,629 B2

25

the first cushioning member **732** defines a longitudinal length **720** defined by a length from a forefoot end (e.g., a distal end **791** of an anterior protrusion **790**) to a heel end **797** (e.g., a heel end of the sole structure **704**), and the second cushioning member **734** defines a longitudinal length **722** defined by a length from a forefoot end **798** and a heel end (e.g., the distal end **795** of the posterior protrusion **796**). Here, the longitudinal length **722** of the second cushioning member **734** is greater than the longitudinal length **720** of the first cushioning member **732**.

Similar to the sole structures **504**, **604**, the sole structure **704** may also include a second plate **760**. In the particular embodiment shown in FIGS. **76-85**, the second plate **760** partially encases the sole plate **736** such that the sole plate **736** sits within the second plate **760**. Additionally, as best shown in FIG. **79**, the second plate **760** extends across the midfoot region **710** and the heel region **712**. Thus, the second plate **760** is only positioned below the sole plate **736** across a portion of the sole plate **736**, and more particularly, the arch or midfoot region thereof. In other embodiments, as previously discussed herein, the second plate **760** may extend across an entire length of the sole plate **736** or may be positioned at a location along the sole structure **704** where the sole plate **736** needs targeted structural support. The second plate **760** may be constructed from similar materials to the sole plate **736**, which have already be discussed herein. However, in particular embodiments, the material used to construct the second plate **760** may differ from the material used to construct the sole plate **736** such that the second plate **760** provides added reinforcement to the sole plate **736**. For example, in one embodiment, the sole plate **736** may be constructed from a carbon fiber material and the second plate **760** may be constructed from thermoplastic polyurethane (TPU) to support the sole plate **736**. Additionally, the second plate **760** may support the structural integrity of the sole plate **736** and prevent the sole plate **736** from fracturing during use thereof.

In addition to the second plate **760**, an amount of material may be injected into one or more grooves of the sole plate **736**. More particularly, in this embodiment, the sole plate **736** may include two grooves **762** formed from a plurality of raised portions **764** (see FIGS. **83**, **86**, and **87**), and material **766** may be injected or positioned within the grooves **762**. Similar to the second plate **760**, the material injected into the grooves **762** may provide further structural support to the sole plate **736** and targeted support to the sole plate **736**. For example, in this particular embodiment, the grooves are provided across the midfoot or arch region of the sole structure **704**, and therefore, the material **766** may provide support to the sole plate **736** in the arch region thereof, which thereby provides further support to a user's foot in the arch region of the sole structure **704**. The injected material **766** may be a suitable plastic material, such as thermoplastic polyurethane (TPU) or the like.

FIGS. **88** and **89** depict the second plate **760** of the present embodiment. Further, as discussed herein in connection with several embodiments, the second plates **560**, **660**, **760** may encase the sole plates **536**, **636**, **736**. To perform this function, the second plate **560**, **660**, **760** may include outer walls or sidewalls **570**, **670**, **770** that extend upward from the main body of the second plate **560**, **660**, **760**. Additionally, the second plate **560**, **660**, **760** may include a shape that conforms to the shape of the sole plate **536**, **636**, **736**. For example, as best shown in FIGS. **88** and **89**, the second plate **760** may include a plurality of raised portions **772** and grooves **774** that conform with the plurality of raised portions **764** and grooves **762** of the sole plate **736**.

26

EXAMPLES

The examples herein are intended to illustrate certain embodiments of the articles of footwear and sole structures discussed herein to one of ordinary skill in the art and should not be interpreted as limiting in the scope of the disclosure set forth in the claims. The articles of footwear and sole structures of the present disclosure may comprise the following non-limiting examples.

Example 1

Several studies were conducted to assess the performance of the sole structures discussed herein in comparison to other comparative sole structures. First, a mean relative maximum oxygen uptake for a subject wearing the sole structures **104**, **204**, **304** was measured and compared to the mean relative maximum oxygen uptake of the subject wearing comparative sole structures. These measurements were performed while the subject was running on a treadmill at various speeds, including 12 km/h, 14 km/h, and 16 km/h. The results of this study are shown in FIG. **90**.

Oxygen uptake or consumption is a measure of a person's ability to take in oxygen and deliver it to the working tissues of an athlete's body, but a lower mean relative maximum oxygen uptake equates to more efficient running. In other words, if a runner is more efficient by way of a more efficient and effective shoe sole, for example, the runner needs a lower amount of oxygen, and therefore, the runner would exhibit a lower mean relative maximum oxygen uptake. With reference to FIG. **90**, the sole structure **304** consistently had the lowest mean relative maximum oxygen uptake compared to other comparative soles across all speeds. However, at the higher speed of 16 km/h, the difference between the oxygen uptake values were accentuated and the article of footwear utilizing the sole structure **304** exhibited a mean relative maximum oxygen uptake of 49.1 ml/min/kg, which was far less than the other shoes having values greater than 51 ml/min/kg. The other sole structures **104**, **204** also exhibited very low oxygen uptake values in comparison to several of the comparative shoes. These results exhibit the improved efficiency the sole structures **104**, **204**, **304** can provide to a runner or athlete.

Example 2

Next, a mean heartrate of a subject wearing a shoe having the sole structures **104**, **204**, **304** was measured and compared to the heartrate of the subject wearing comparative sole structures. These measurements were performed while the subject was running on a treadmill at various speeds, including 12 km/h, 14 km/h, and 16 km/h.

The heartrate of a subject, like oxygen uptake, can be a measure of the efficiency of a runner and the efficiency of a sole structure worn by a runner. For example, if a runner is more efficient by way of a more efficient and effective sole structure, for example, the runner would have a lower mean heartrate. With reference to FIG. **91**, a runner wearing each sole structure **104**, **204**, **304** had a lower heartrate compared to several comparative shoe soles, which exhibits the improved efficiency imparted on a runner wearing a shoe having the sole structures **104**, **204**, **304**.

Example 3

The perceived exertion of the subjects was also documented after a subject ran on a treadmill at several speeds,

US 11,974,629 B2

27

including 12 km/h, 14 km/h, and 16 km/h. More particularly, a subject was asked to run at a speed of 12 km/h, for example, and then asked to provide a rating of perceived exertion from a zero to ten scale with zero indicating no perceived level of exertion and ten indicating a very high level of perceived exertion by the subject. These values were documented for articles of footwear having the sole structures **104**, **204**, **304**, compared with several comparative shoe soles, and then graphed. The results of this experiment are shown in FIG. **92**, and as shown in FIG. **92**, runners or subjects consistently provided low ratings for articles of footwear having the sole structures **104**, **204**, **304**. In particular, subjects consistently provided the lowest mean rating of perceived exertion for the sole structure **304** compared to the other sole structures, which shows the beneficial experience subjects or runners have with the sole structure **304** during use thereof.

Example 4

The mean lactate concentration for a subject wearing the sole structures **104**, **204**, **304** was also measured and compared to the lactate concentration of a subject or runner wearing articles of footwear with comparable sole structures. These measurements were performed while the subject was running on a treadmill at various speeds, including 12 km/h, 14 km/h, and 16 km/h. The results of this study are shown in FIG. **93**.

Blood lactate levels can serve as an indirect marker for biochemical events, such as fatigue within exercising muscle. Further, the concentration of blood lactate is usually 1-2 mmol/L at rest, but can rise to greater than 20 mmol/L during intense exertion. In short, the higher lactate concentration within the blood is an indication of fatigue for a runner. Therefore, lower lactate concentrations are desired because lower lactate concentrations indicate more efficient running and a more efficient sole structure that provides a higher level of performance to a runner. With reference to FIG. **93**, each sole structure **104**, **204**, **304** performed exceptionally compared to other sole structures and provided low lactate concentrations compared to the other tested sole structures. As previously discussed herein, higher speeds (such as 16 km/h) can provide clearer data and more accentuated differences between the sole structures, and looking to the data collected at a running speed of 16 km/h, the sole structures **104**, **204**, **304** each registered lactate concentrations of about 3.2 mmol/l, which were significantly lower than the other comparable sole structures. As should be understood by one of ordinary skill in the art, these differences in lactate concentration (or decrease in lactate formation) can have a drastic and positive impact on runners during training, recovery, and performance activities, especially athletes or runners in endurance sports (e.g., marathon runners).

Example 5

In addition to measuring a lactate concentration of a subject or runner, a regression analysis rating of feeling and lactate concentration was performed. More particularly, for each sole structure, the subject or runner provided a perceived level of exhaustion using a zero to ten scale, with zero indicating no perceived level of exhaustion and ten indicating a very high level of exhaustion. Then these values were graphed with the lactate concentrations collected from Example 4 previously discussed herein. Specifically, for each speed and for each sole structure, the perceived levels

28

of exhaustion for a runner were placed on a y-axis and their lactate concentrations were placed on the x-axis. This graph is shown in FIG. **94** and a regression analysis was performed to determine the statistical link between blood lactate concentration levels and perceived levels of exhaustion. After performing the regression analysis, the graph of FIG. **94** had an R-squared value of 0.92, thereby showing a strong statistical link between how tired runners felt and their lactate concentration in their blood.

Any of the embodiments described herein may be modified to include any of the structures or methodologies disclosed in connection with different embodiments. Further, the present disclosure is not limited to articles of footwear of the type specifically shown. Still further, aspects of the articles of footwear of any of the embodiments disclosed herein may be modified to work with any type of footwear, apparel, or other athletic equipment.

As noted previously, it will be appreciated by those skilled in the art that while the invention has been described above in connection with particular embodiments and examples, the invention is not necessarily so limited, and that numerous other embodiments, examples, uses, modifications and departures from the embodiments, examples and uses are intended to be encompassed by the claims attached hereto. The entire disclosure of each patent and publication cited herein is incorporated by reference, as if each such patent or publication were individually incorporated by reference herein. Various features and advantages of the invention are set forth in the following claims.

INDUSTRIAL APPLICABILITY

Numerous modifications to the present invention will be apparent to those skilled in the art in view of the foregoing description. Accordingly, this description is to be construed as illustrative only and is presented for the purpose of enabling those skilled in the art to make and use the invention. The exclusive rights to all modifications which come within the scope of the appended claims are reserved.

We claim:

1. An article of footwear having a sole structure and an upper, the sole structure comprising:

a first cushioning member directly coupled to the upper and extending continuously between a heel region and a midfoot region of the sole structure; and

a second cushioning member directly coupled to the upper and extending continuously between a forefoot region and the midfoot region of the sole structure,

wherein the first cushioning member and the second cushioning member overlap in the midfoot region and are spaced apart to define a gap that extends between the first cushioning member and the second cushioning member in the midfoot region of the sole structure, the gap having a centerline defined between the first cushioning member and the second cushioning member, the centerline following a contour of an end of at least one of the first cushioning member and the second cushioning member that bounds the gap when viewed from a bottom of the article of footwear; and

wherein at least one of the first cushioning member or the second cushioning member are a supercritical foam.

2. The article of footwear of claim 1, further including an outsole defining a ground engaging surface, the outsole including a first outsole portion coupled to the first cushioning member and a second outsole portion coupled to the second cushioning member so that the ground engaging surface is not continuous along the midfoot region.

US 11,974,629 B2

29

3. The article of footwear of claim 2, wherein the first outsole portion includes a first heel outsole portion and a second heel outsole portion that are spaced apart from one another.

4. The article of footwear of claim 3, wherein a groove extends between the first heel outsole portion and the second heel outsole portion.

5. The article of footwear of claim 1, wherein the gap extends along a non-linear path between a lateral side and a medial side of the sole structure.

6. The article of footwear of claim 5, wherein the non-linear path is a U-shaped path.

7. The article of footwear of claim 1, wherein the first cushioning member includes an anterior protrusion that extends toward the second cushioning member, and the second cushioning member includes a posterior protrusion that extends toward the first cushioning member.

8. The article of footwear of claim 7, wherein a terminal end of the anterior protrusion is disposed closer to a toe end of the sole structure than is a terminal end of the posterior protrusion.

9. The article of footwear of claim 1, wherein the first cushioning member includes a distal end that terminates in the midfoot region of the sole structure and the second cushioning member includes a distal end that terminates in the midfoot region of the sole structure.

10. The article of footwear of claim 9, wherein the first cushioning member and the second cushioning member overlap in the midfoot region of the sole structure, such that at least a portion of the distal end of the first cushioning member extends past at least a portion of the distal end of the second cushioning member.

11. The article of footwear of claim 1, wherein the supercritical foam is formed by pressurizing a mixture of a supercritical fluid that includes nitrogen and a molten material of the cushioning member and then releasing the pressure to convert the supercritical fluid to a gas, which causes the material to expand and foam, thereby forming the pockets within the molten material.

12. An article of footwear having a sole structure and an upper, the sole structure comprising:

a midsole having a first cushioning member that is decoupled from a second cushioning member to define a gap therebetween that extends from a lateral side of the midsole to a medial side of the midsole,

wherein the first cushioning member extends at least partially through a midfoot region and includes a distal end that is U-shaped to define a notch between a first protrusion and a second protrusion,

wherein the second cushioning member extends at least partially through the midfoot region and includes a rounded distal end defining a third protrusion that extends toward the notch defined by the first cushioning member, and

wherein at least one of the first cushioning member of the second cushioning member are a supercritical foam, and

wherein the first cushioning member and the second cushioning member overlap in the midfoot region of the sole structure, such that at least a portion of the distal end of the first cushioning member extends past the rounded distal end of the second cushioning member.

13. The article of footwear of claim 12, wherein a bottom surface of the upper is exposed along the gap between the first cushioning member and the second cushioning member.

30

14. The article of footwear of claim 12, wherein the first cushioning member and the second cushioning member overlap so that, when viewed from a bottom of the article of footwear, the third protrusion extends into the notch while maintaining the gap between the first cushioning member and the second cushioning member.

15. The article of footwear of claim 14, wherein both the first protrusion and the second protrusion extend past the third protrusion in a longitudinal direction.

16. The article of footwear of claim 12, wherein the first cushioning member defines a first flex region and a second flex region that are separated by a flex groove.

17. The article of footwear of claim 16, wherein a first outsole portion includes a first outsole element coupled to the first flex region and a second outsole element coupled to the second flex region.

18. The article of footwear of claim 12, wherein the rounded distal end of the second cushioning member extends into the U-shaped distal end of the first cushioning member, such that the U-shaped distal end of the first cushioning member wraps around the rounded distal end of the second cushioning member while maintaining the gap therebetween.

19. The article of footwear of claim 12, wherein the sole structure further includes an outsole defining a ground engaging surface and including a first outsole portion coupled to the first cushioning member and a second outsole portion coupled to the second cushioning member so that the ground engaging surface is not continuous along a midfoot region of the sole structure.

20. The article of footwear of claim 12, wherein the supercritical foam is formed by pressurizing a mixture of a supercritical fluid that includes nitrogen and a molten material of the cushioning member and then releasing the pressure to convert the supercritical fluid to a gas, which causes the material to expand and foam, thereby forming the pockets within the molten material.

21. The article of footwear of claim 12, wherein the first cushioning member is positioned in a heel region and the second cushioning member is positioned in a forefoot region.

22. The article of footwear of claim 12, wherein the gap has a centerline defined between the first cushioning member and the second cushioning member, the centerline following a contour of an end of both the first cushioning member and the second cushioning member that bounds the gap when viewed from a bottom of the article of footwear.

23. An article of footwear having a sole structure and an upper, the sole structure comprising:

an outsole defining a ground-engaging surface;

a first cushioning member disposed between the outsole and the upper in a heel region of the sole structure, the first cushioning member including an anterior protrusion that extends into a midfoot region of the sole structure; and

a second cushioning member disposed between the outsole and the upper in a forefoot region of the sole structure, the second cushioning member including a posterior protrusion that extends into the midfoot region of the sole structure;

wherein the first cushioning member and the second cushioning member overlap in the midfoot region so that a toe end of the anterior protrusion extends past a heel end of the posterior protrusion in a longitudinal direction so that the toe end of the anterior protrusion is positioned closer to the forefoot region than is the heel end of the posterior protrusion,

wherein a gap extends between the first cushioning member and the second cushioning member from a lateral side of the sole structure to a medial side of the sole structure, the gap having a centerline defined between the first cushioning member and the second cushioning member, the centerline following a contour of an end of at least one of the first cushioning member and the second cushioning member, and
wherein at least one of the first cushioning member or the second cushioning member are supercritical foams.

24. The article of footwear of claim **23**, wherein the second cushioning member includes a longitudinal length defined by a length from a forefoot end of the second cushioning member to the heel end of the posterior protrusion, wherein the first cushioning member includes a longitudinal length defined by a length from the toe end of the anterior protrusion to a heel end of the first cushioning member, and wherein the longitudinal length of the second cushioning member is greater than the longitudinal length of the first cushioning member.

25. The article of footwear of claim **23**, wherein the posterior protrusion is positioned along a medial half of the sole structure.

26. The article of footwear of claim **23**, wherein the supercritical foam is formed by pressurizing a mixture of a supercritical fluid that includes nitrogen and a molten material of the cushioning member and then releasing the pressure to convert the supercritical fluid to a gas, which causes the material to expand and foam, thereby forming the pockets within the molten material.

* * * * *

EXHIBIT C



US011974630B2

(12) **United States Patent**
Bonin et al.

(10) **Patent No.:** **US 11,974,630 B2**
(45) **Date of Patent:** **May 7, 2024**

(54) **ARTICLE OF FOOTWEAR HAVING A SOLE PLATE**

(56) **References Cited**

(71) Applicant: **PUMA SE**, Herzogenaurach (DE)
(72) Inventors: **Mauro Bonin**, Nuremberg (DE);
Andreas Siegmund, Rückersdorf (DE); **Arnaud Redon**, Nuremberg (DE)
(73) Assignee: **PUMA SE**, Herzogenaurach (DE)

U.S. PATENT DOCUMENTS

324,065 A	8/1885	Andrews
413,693 A	10/1889	Walker
634,588 A	10/1899	Roche
1,088,328 A	2/1914	Cucinotta et al.
4,020,569 A	5/1977	Fukuoka
4,241,523 A	12/1980	Daswick
4,348,821 A	9/1982	Daswick

(*) Notice: Subject to any disclaimer, the term of this patent is extended or adjusted under 35 U.S.C. 154(b) by 0 days.

FOREIGN PATENT DOCUMENTS

CN	2904704 Y	5/2007
CN	204132549 U	2/2015

(21) Appl. No.: **18/243,981**

(22) Filed: **Sep. 8, 2023**

(Continued)

(65) **Prior Publication Data**

US 2023/0413945 A1 Dec. 28, 2023

OTHER PUBLICATIONS

International Search Report of International Application No. PCT/IB2021/062487, dated Mar. 30, 2022, 7 pages.

(Continued)

Related U.S. Application Data

(63) Continuation of application No. 18/109,991, filed on Feb. 15, 2023, which is a continuation of application No. 17/218,353, filed on Mar. 31, 2021.

Primary Examiner — Khoa D Huynh
Assistant Examiner — Haley A Smith

(60) Provisional application No. 63/139,447, filed on Jan. 20, 2021.

(74) *Attorney, Agent, or Firm* — Quarles & Brady LLP

(51) **Int. Cl.**
A43B 13/18 (2006.01)

(57) **ABSTRACT**

(52) **U.S. Cl.**
CPC **A43B 13/186** (2013.01); **A43B 13/183** (2013.01); **A43B 13/188** (2013.01)

An article of footwear includes an upper and a sole structure coupled to the upper. The sole structure defines a ground engaging surface, and includes a cushioning member coupled to the upper and an outsole coupled to the cushioning member. The outsole includes a central portion and a plurality of lobes extending outward from a periphery of the central portion. Each of the plurality of lobes is independently movable relative to one another.

(58) **Field of Classification Search**
CPC ... A43B 13/186; A43B 13/188; A43B 13/026; A43B 13/145; A43B 13/185; A43B 13/26; A43B 13/183; A43B 13/181; A43B 13/141; A43B 13/122; A43B 5/06; A43C 15/02; A43C 15/16; A43C 15/161; A43C 15/162; A43C 15/168

See application file for complete search history.

29 Claims, 40 Drawing Sheets

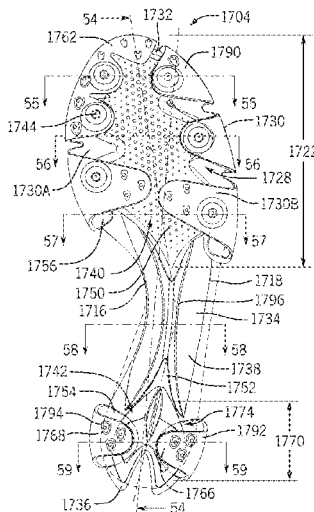

US 11,974,630 B2

Page 3

(56)		References Cited					
U.S. PATENT DOCUMENTS				2020/0281314	A1*	9/2020	Stockbridge B29D 35/128
2009/0183393	A1	7/2009	Lee	2020/0281322	A1	9/2020	Caldwell et al.
2009/0249648	A1*	10/2009	Brown A43B 13/26	2020/0307134	A1	10/2020	Yoshida
			36/134	2021/0015209	A1	1/2021	Buck
2009/0307925	A1	12/2009	Pfister	2021/0030112	A1	2/2021	Amoako et al.
2010/0175280	A1	7/2010	Rinehart, Jr.	2021/0052037	A1	2/2021	Greenspan
2010/0186261	A1	7/2010	Baker	2021/0085024	A1	3/2021	Chen
2010/0218397	A1	9/2010	Nishiwaki et al.	2021/0368916	A1	12/2021	Wakasugi
2010/0263228	A1	10/2010	Kang	2022/0015505	A1	1/2022	Constantinou
2011/0088287	A1*	4/2011	Auger A43B 13/125	FOREIGN PATENT DOCUMENTS			
			36/114	CN	204467084	U	7/2015
2011/0138652	A1*	6/2011	Lucas A43B 13/14	DE	4015138	A1	11/1991
			36/28	DE	102012104264	A1	11/2013
2011/0214314	A1*	9/2011	Baker A43C 15/168	DE	102018122753	A1	3/2019
			36/134	DE	102019107402	A1	9/2019
2012/0079747	A1*	4/2012	Seo A43B 13/183	EP	1483981	A1	12/2004
			36/25 R	EP	1346655	B1	8/2006
2012/0174432	A1	7/2012	Peyton	EP	1525284	B1	6/2007
2012/0317835	A1	12/2012	Raysse et al.	EP	2138063	A1	12/2009
2013/0067772	A1*	3/2013	Auger A43B 13/188	EP	2689681	A1	1/2014
			36/103	EP	2491807	B1	10/2014
2013/0192090	A1	8/2013	Smith	EP	1847193	B1	1/2015
2013/0199057	A1*	8/2013	Hurd A43B 13/184	EP	1386553	B1	6/2015
			36/88	EP	2269478	B1	9/2015
2014/0068966	A1	3/2014	Chaffin	EP	1690460	B1	8/2016
2014/0101972	A1*	4/2014	Ha A43B 13/181	EP	1894484	B1	3/2018
			36/102	EP	2979567	B1	10/2018
2014/0230280	A1	8/2014	Heard et al.	EP	3399882	A1	11/2018
2014/0230283	A1	8/2014	Cordova	EP	2911542	B1	12/2018
2014/0237852	A1	8/2014	Oberschneider et al.	EP	3422893	A1	1/2019
2014/0245640	A1	9/2014	Heard et al.	EP	3434132	A1	1/2019
2015/0047224	A1	2/2015	Zhao et al.	EP	3174419	B1	7/2019
2015/0107132	A1	4/2015	Takeshita	EP	3574791	A1	12/2019
2016/0000180	A1*	1/2016	Cook A43B 13/122	EP	2938218	B1	3/2020
			36/103	EP	3331393	B1	4/2020
2016/0001478	A1*	1/2016	Cook A43C 15/02	EP	3316721	B1	5/2020
			264/244	EP	3457882	B1	6/2020
2016/0262492	A1	9/2016	Fujita	EP	3355738	B1	8/2020
2017/0079376	A1	3/2017	Bunnell et al.	EP	3689171	A1	8/2020
2017/0105477	A1	4/2017	Wilkerson	EP	3771358	A1	2/2021
2017/0150779	A1	6/2017	Walker et al.	FR	2827126	A1	1/2003
2017/0150780	A1	6/2017	Walker	FR	2932963	B1	8/2010
2017/0196305	A1	7/2017	Barnes	FR	2993758	B1	3/2015
2017/0245590	A1	8/2017	Kohatsu et al.	GB	2376408	A	12/2002
2018/0027922	A1	2/2018	Orand	KR	100844183	B1	7/2008
2018/0035752	A1	2/2018	Walker et al.	WO	9842221	A1	10/1998
2018/0042338	A1	2/2018	Orand	WO	2000074515	A1	12/2000
2018/0146743	A1	5/2018	Amos	WO	2007113595	A2	10/2007
2018/0153254	A1	6/2018	Fusco et al.	WO	2008125716	A1	10/2008
2018/0168281	A1	6/2018	Case et al.	WO	2011020798	A1	2/2011
2018/0199666	A1	7/2018	Moriyasu et al.	WO	2013023163	A1	2/2013
2018/0199675	A1	7/2018	Cook et al.	WO	2016094714	A1	6/2016
2018/0235310	A1	8/2018	Wardlaw et al.	WO	2017023532	A1	2/2017
2018/0271215	A1	9/2018	Foxen	WO	2017120006	A1	7/2017
2018/0338568	A1	11/2018	Chambers et al.	WO	2017151501	A1	9/2017
2018/0352902	A1	12/2018	Wardle	WO	2019157244	A1	8/2019
2019/0082781	A1	3/2019	Iuchi et al.	WO	2021016163	A1	1/2021
2019/0150558	A1	5/2019	Shorten	OTHER PUBLICATIONS			
2019/0150563	A1	5/2019	Shorten	Written Opinion of International Application No. PCT/IB2021/062487, dated Mar. 30, 2022, 7 pages.			
2019/0159547	A1	5/2019	Nakatsuka	[Adidas Adizero], available on Amazon.com, Nov. 23, 2015 [online], [May 5, 2023], Available from the internet URL: https:// www.amazon.com/adidas-Adizero-Prime-Collegiate-White/dp/B0119E37WS/ref=cm_cr_arp_d_product_top?ie=UTF8 (Year: 2015), 4 pages.			
2019/0216169	A1	7/2019	Yahata	[Puma EvoSpeed Sprint 14], announced on YouTube on Jan. 5, 2023 [online], [site visited May 5, 2023], Available from the internet URL: Puma evoSpeed Sprint 14 SKU: 9787857 (Year: 2023), 3 pages.			
2019/0246738	A1*	8/2019	Connell A43B 23/0245				
2019/0283355	A1	9/2019	Bartel et al.				
2019/0289961	A1	9/2019	Iuchi et al.				
2019/0320759	A1	10/2019	Conrad et al.				
2019/0365030	A1	12/2019	Chambers et al.				
2019/0365033	A1	12/2019	Chambers et al.				
2019/0365034	A1	12/2019	Connell et al.				
2019/0373982	A1	12/2019	Dupre et al.				
2020/0008519	A1	1/2020	Farris et al.				
2020/0046068	A1	2/2020	Choi et al.				
2020/0100564	A1	4/2020	Bunnell et al.				
2020/0121021	A1	4/2020	Bartel et al.				

* cited by examiner

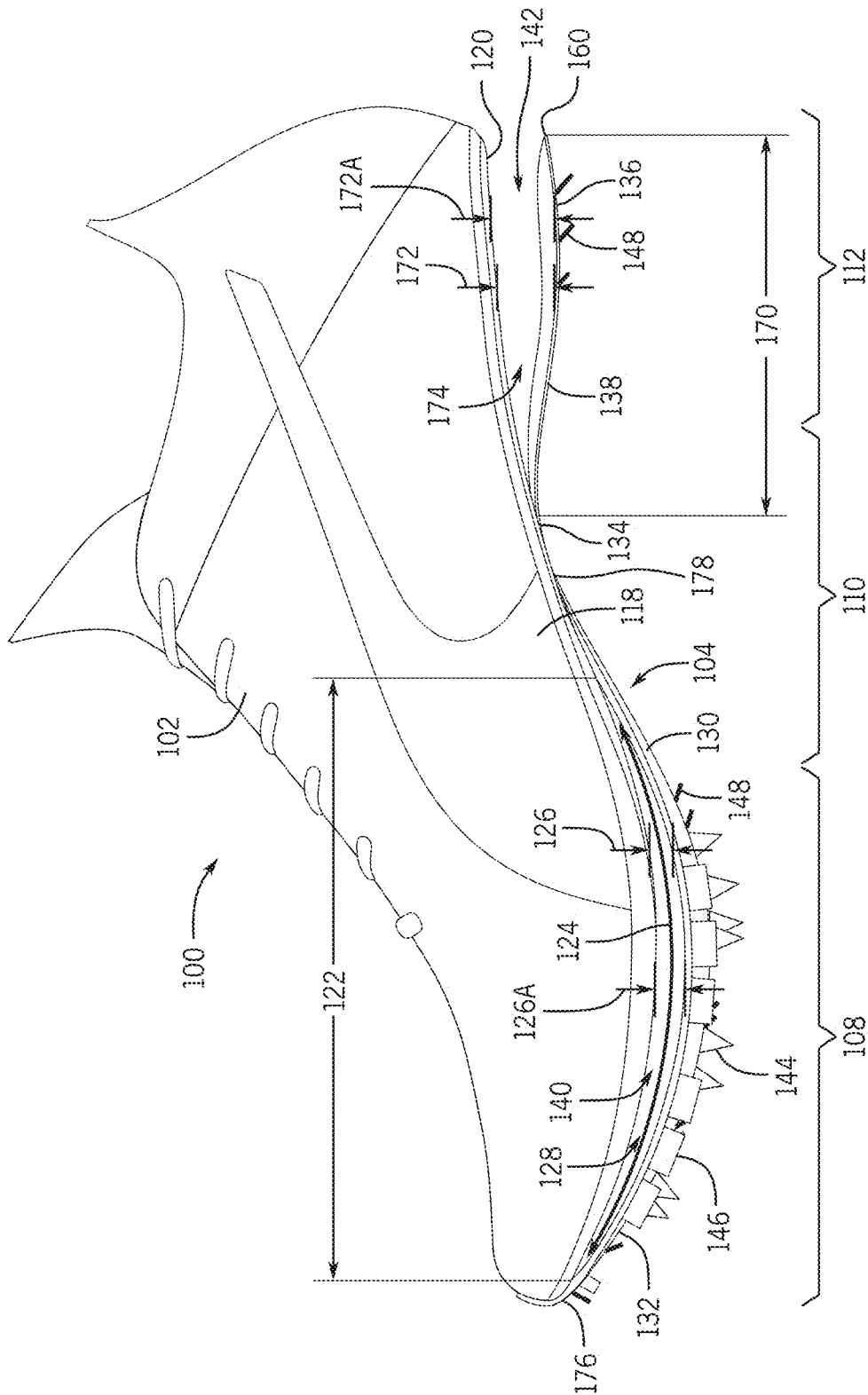

FIG. 1

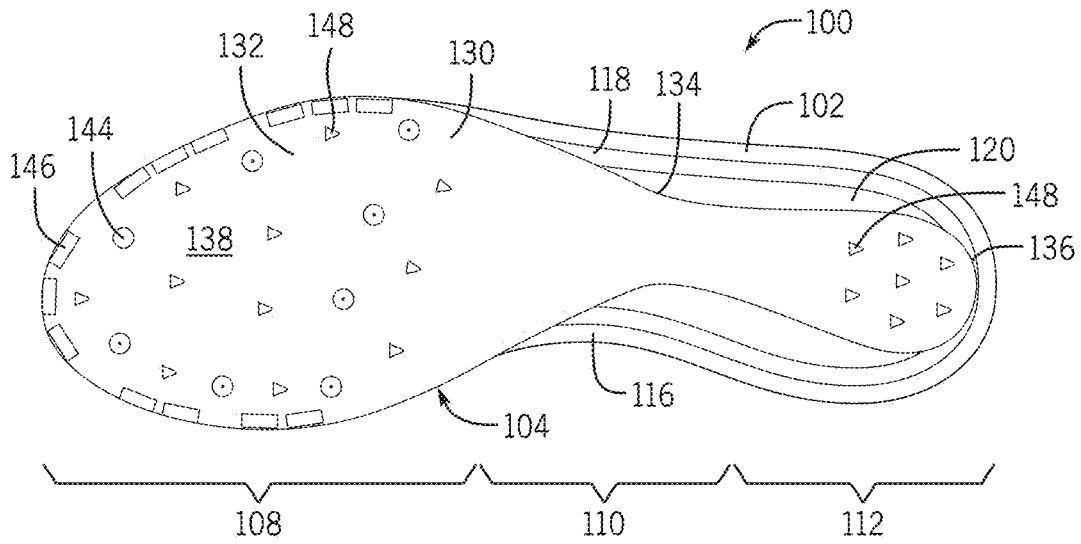

FIG. 2

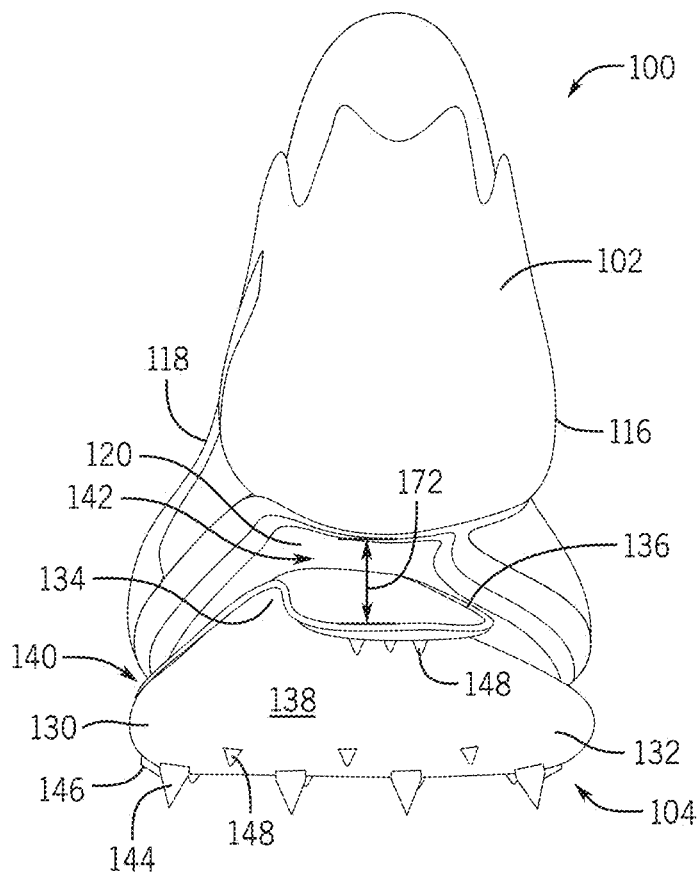

FIG. 3

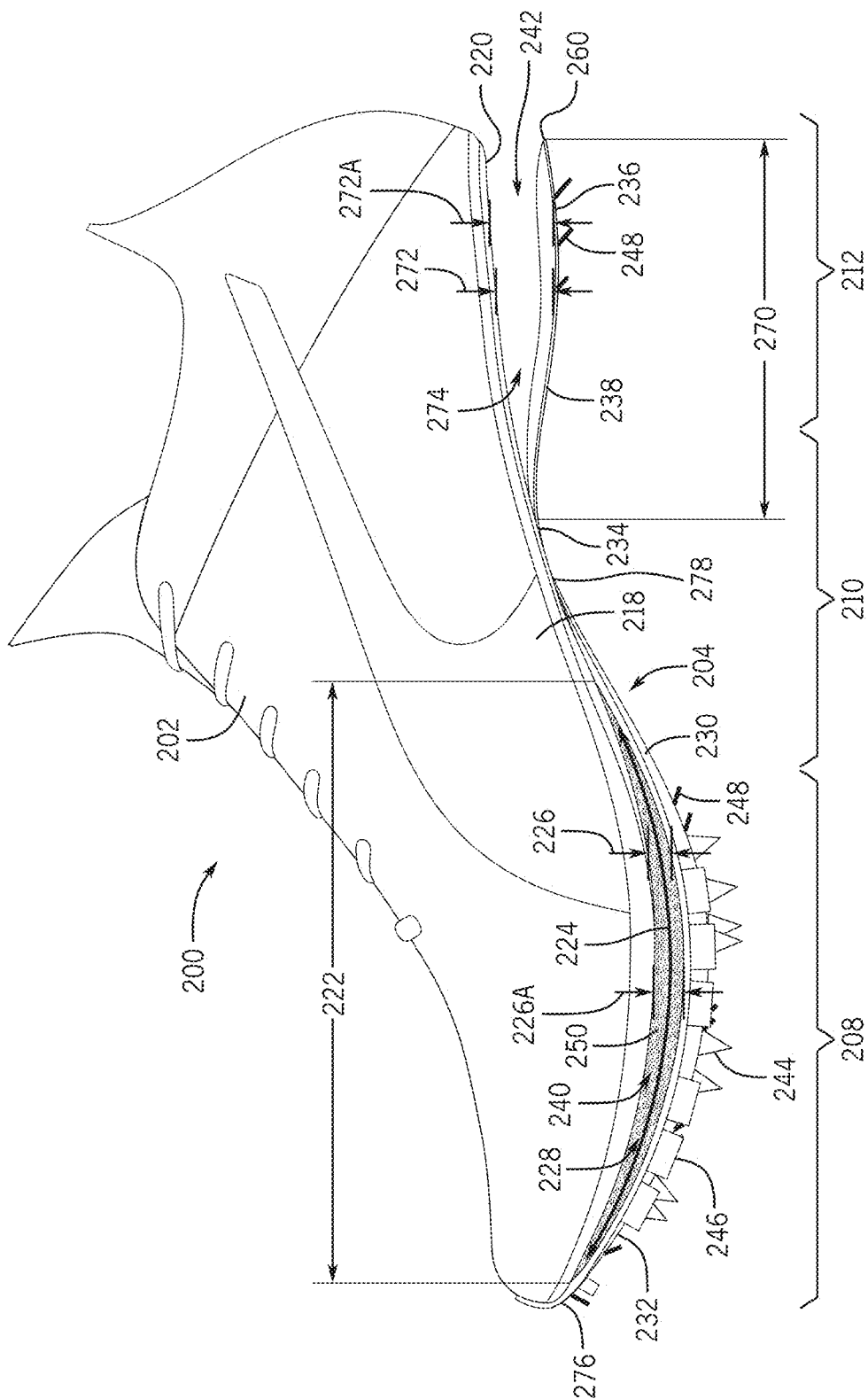

FIG. 4

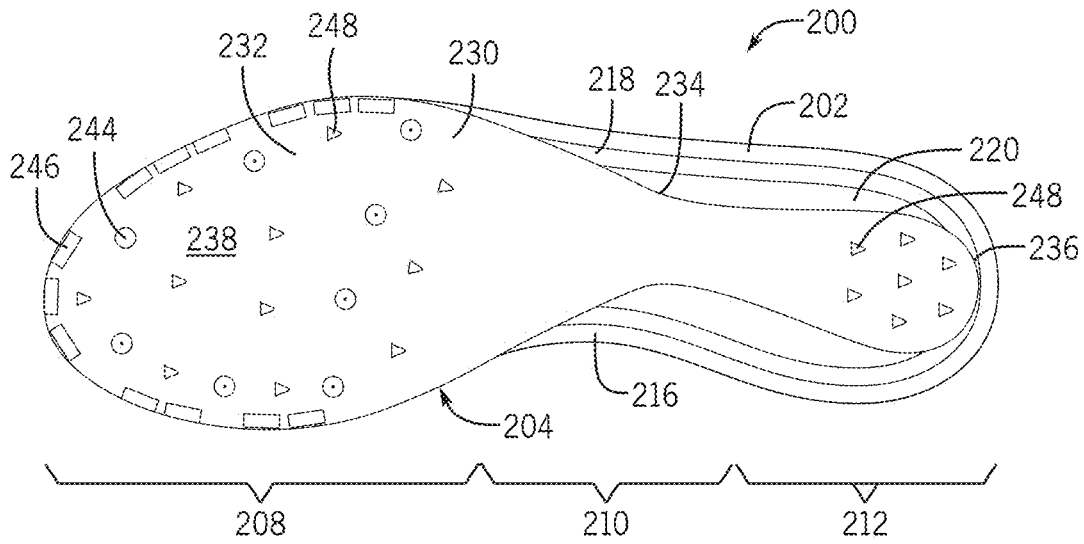

FIG. 5

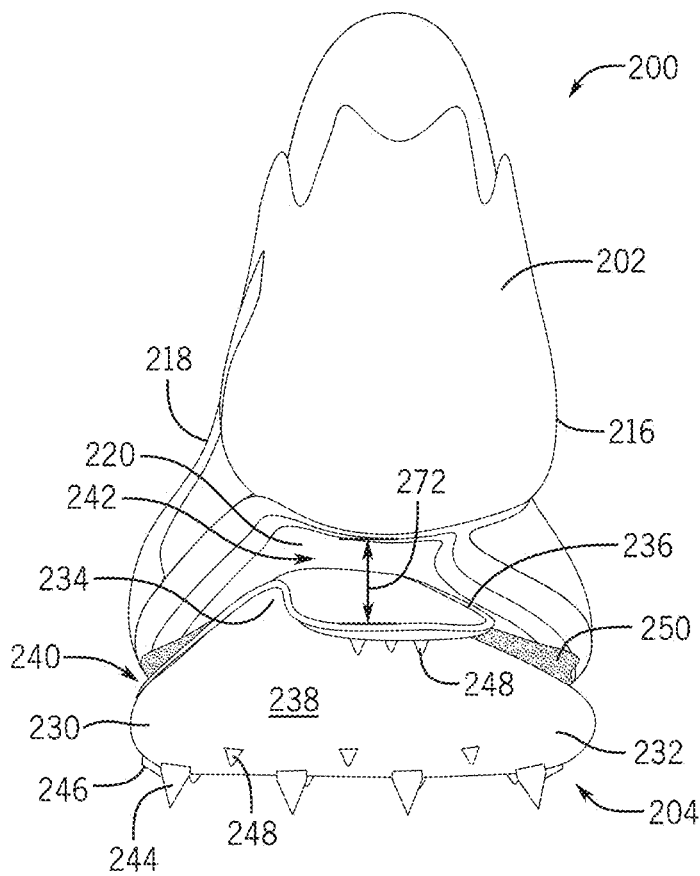

FIG. 6

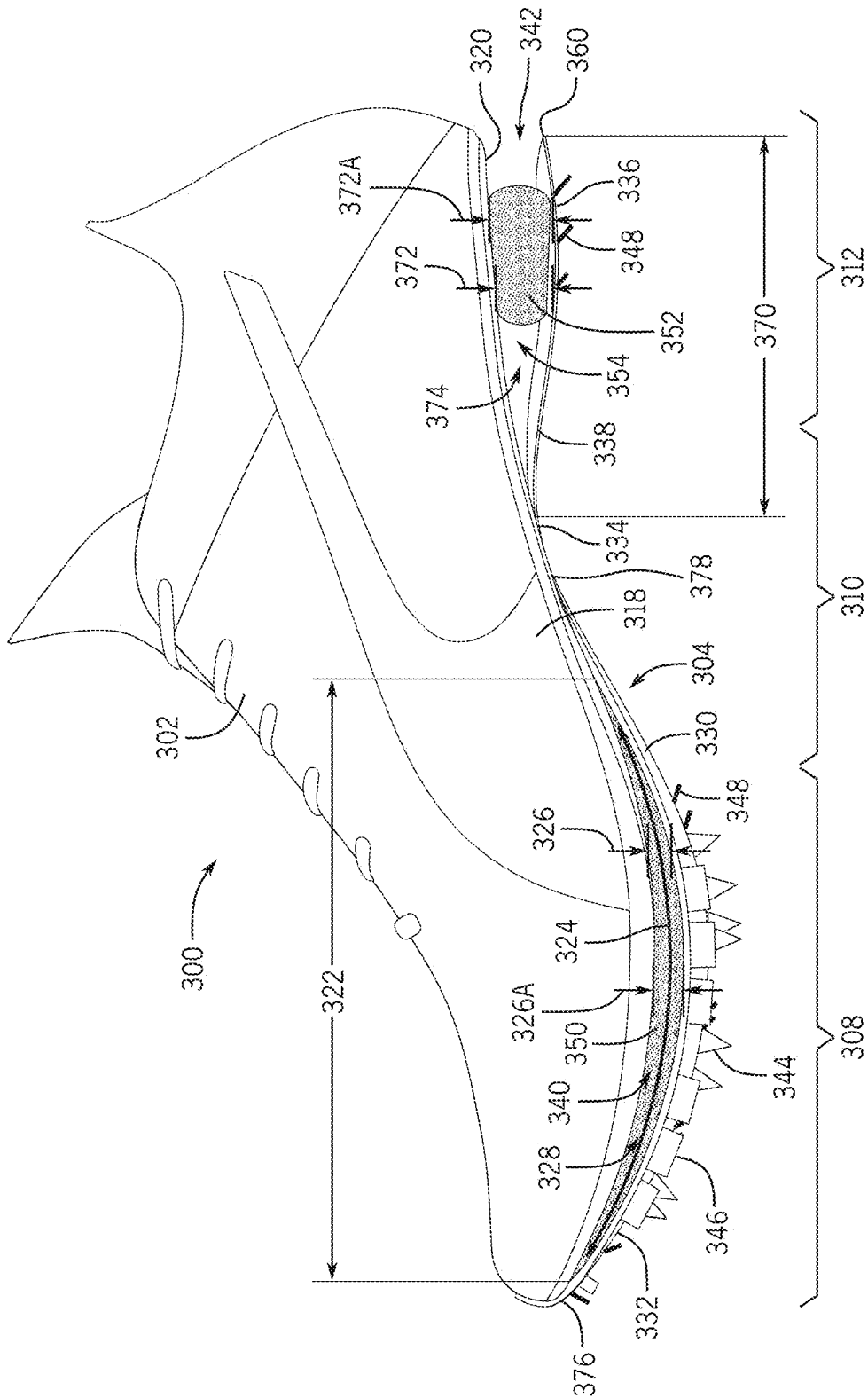

FIG. 7

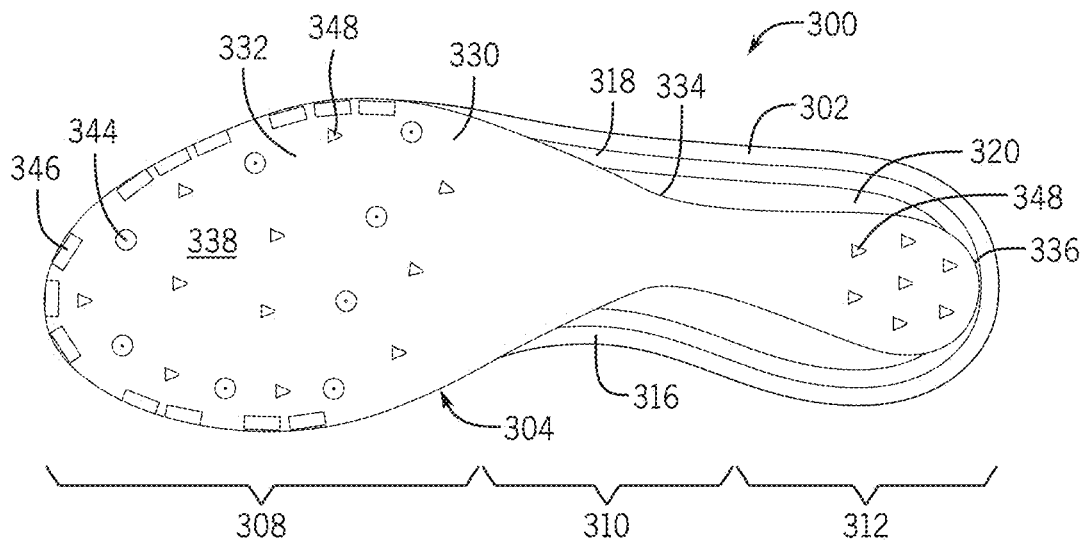

FIG. 8

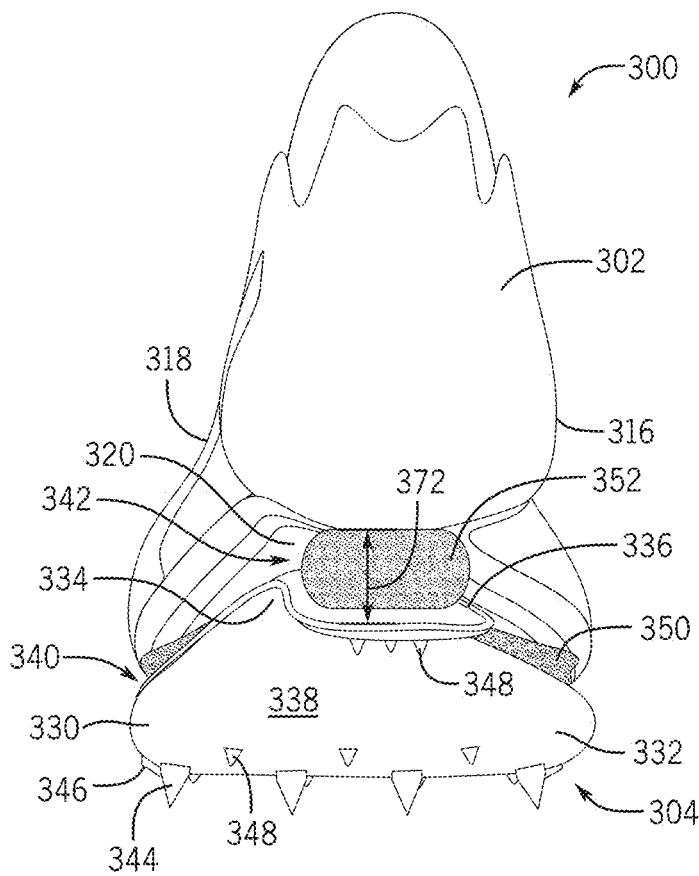

FIG. 9

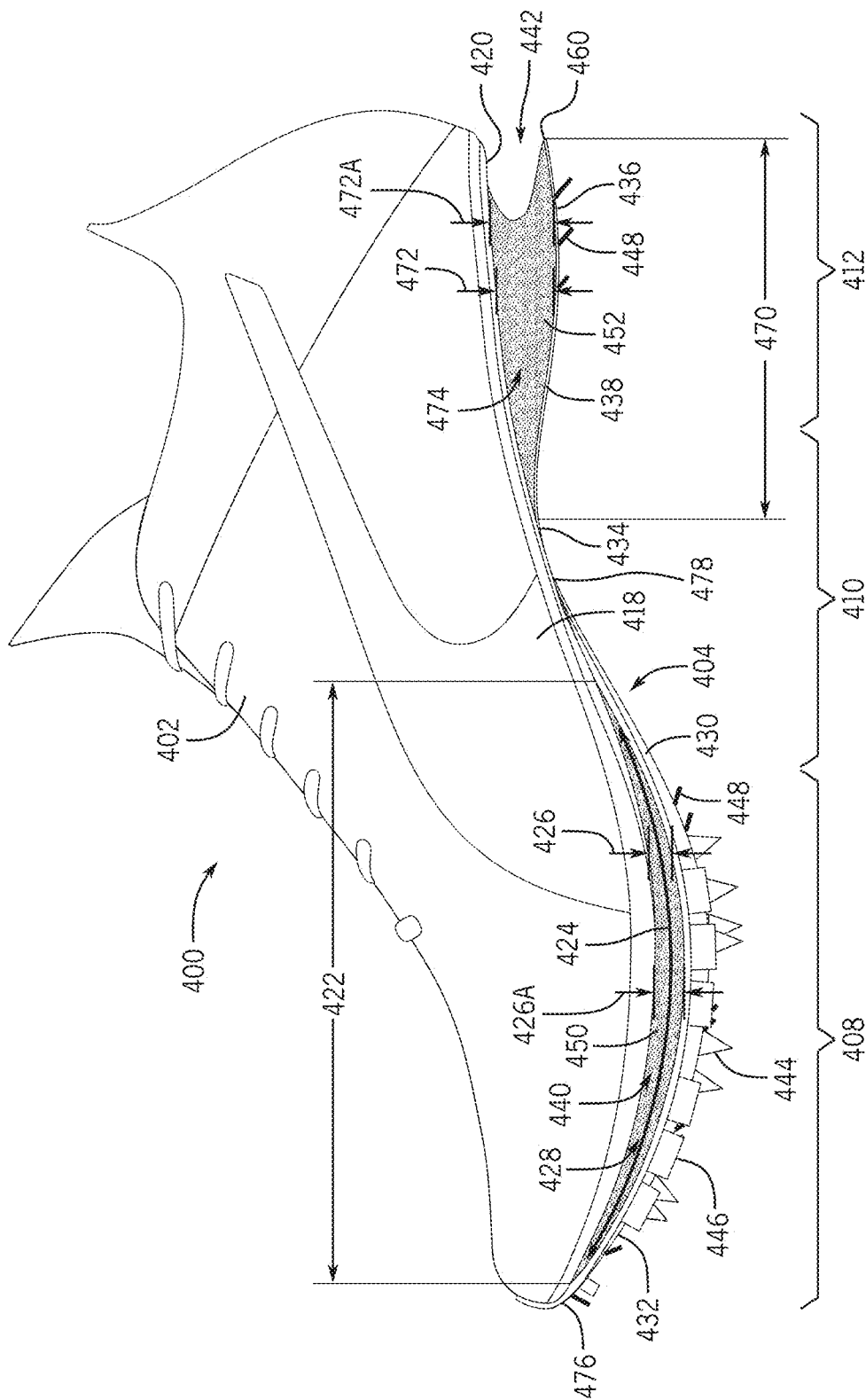

FIG. 10

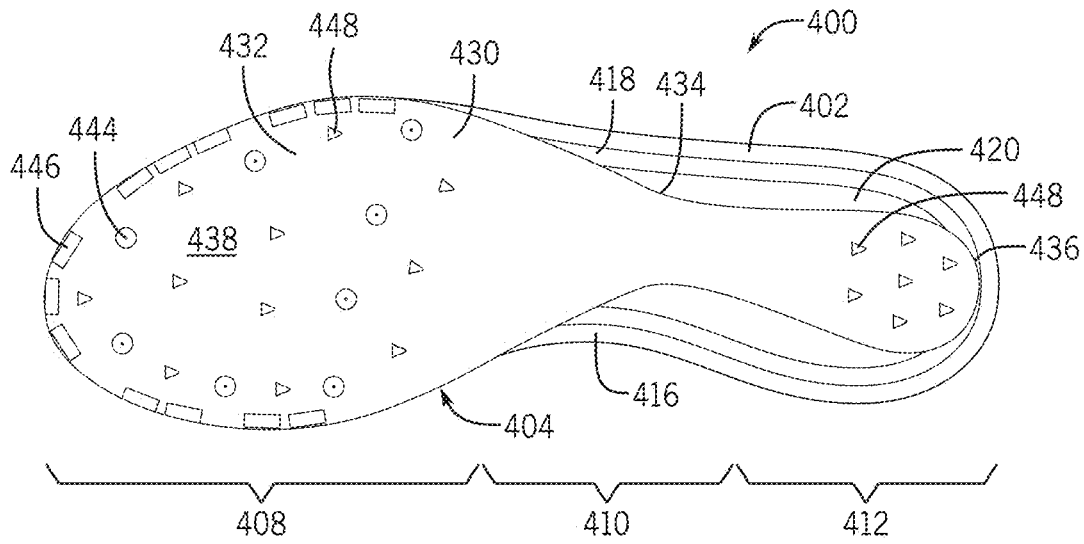

FIG. 11

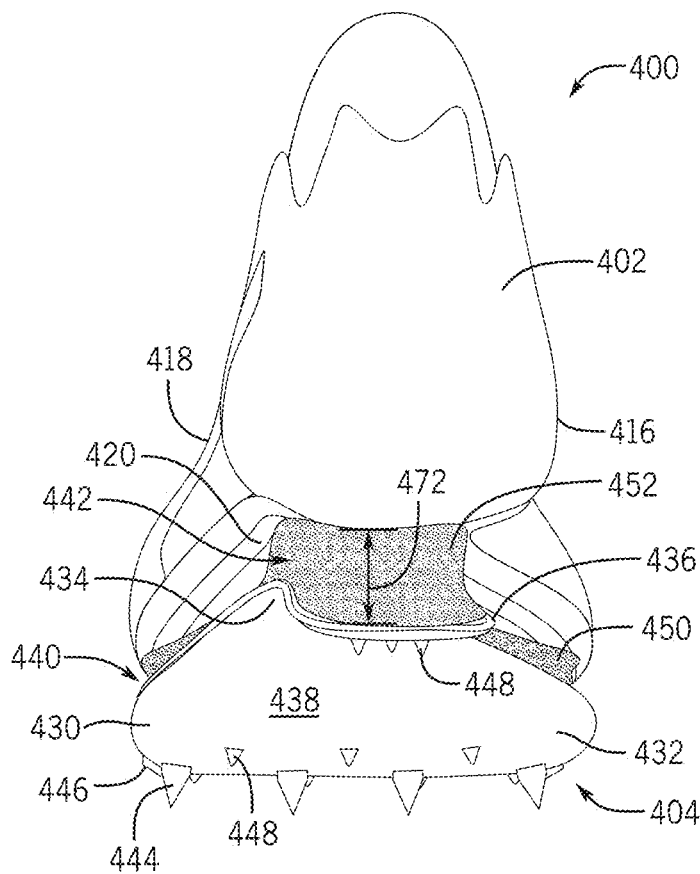
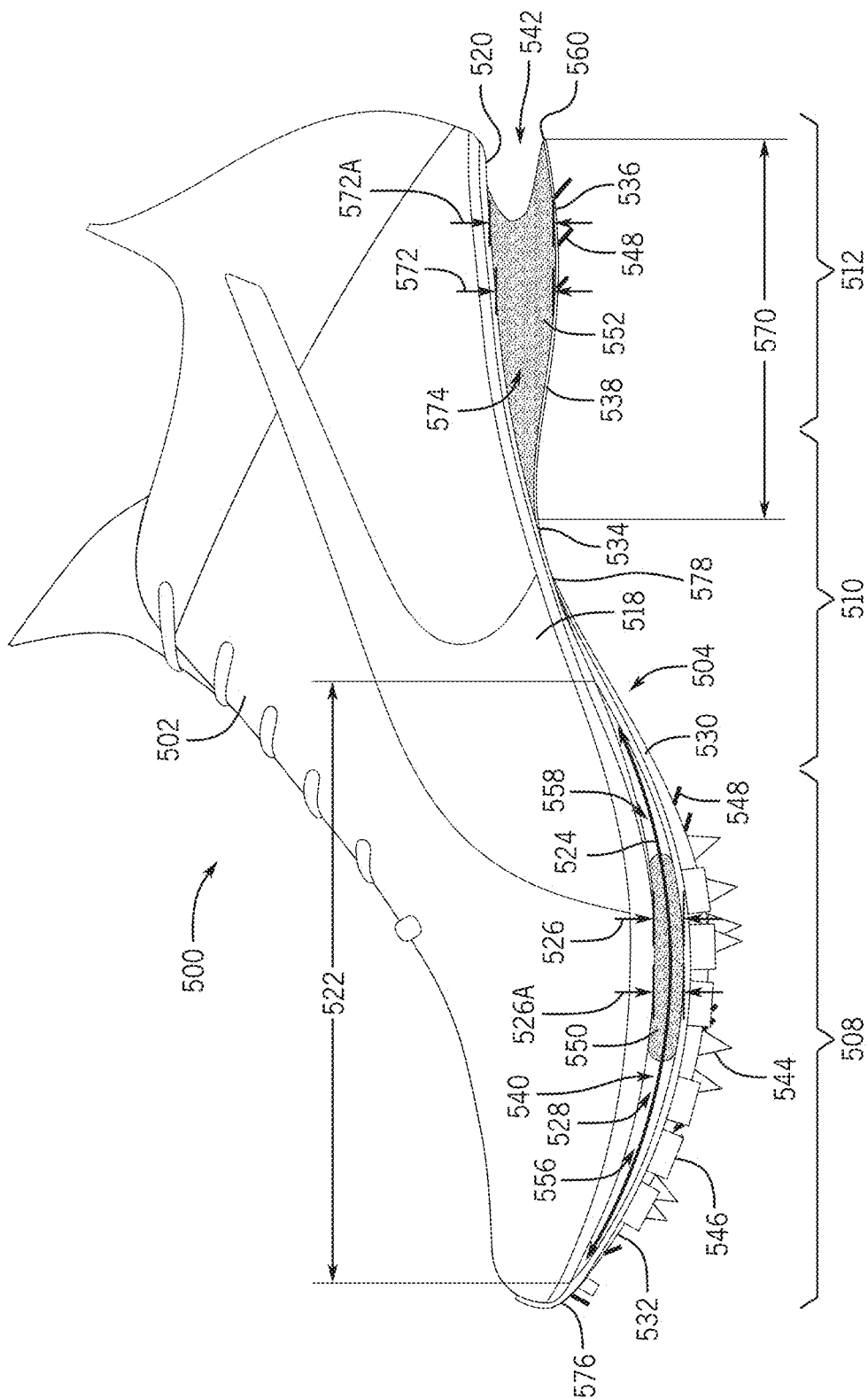

FIG. 12



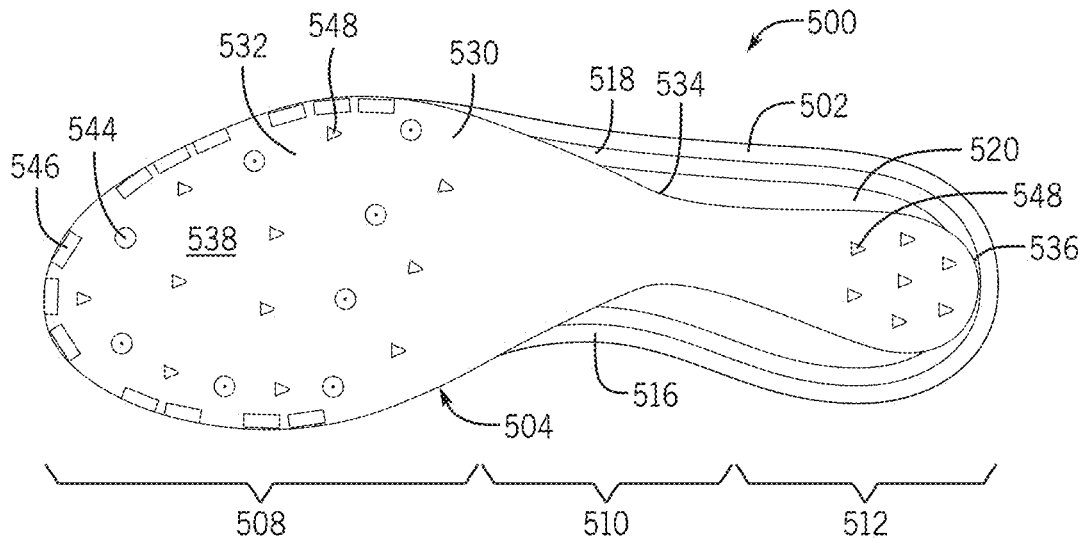

FIG. 14

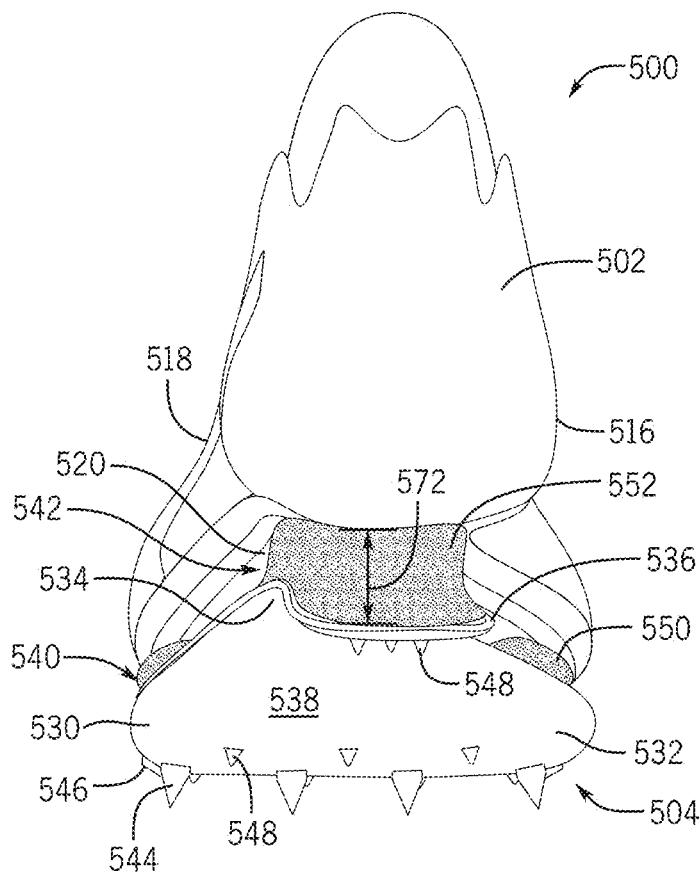

FIG. 15

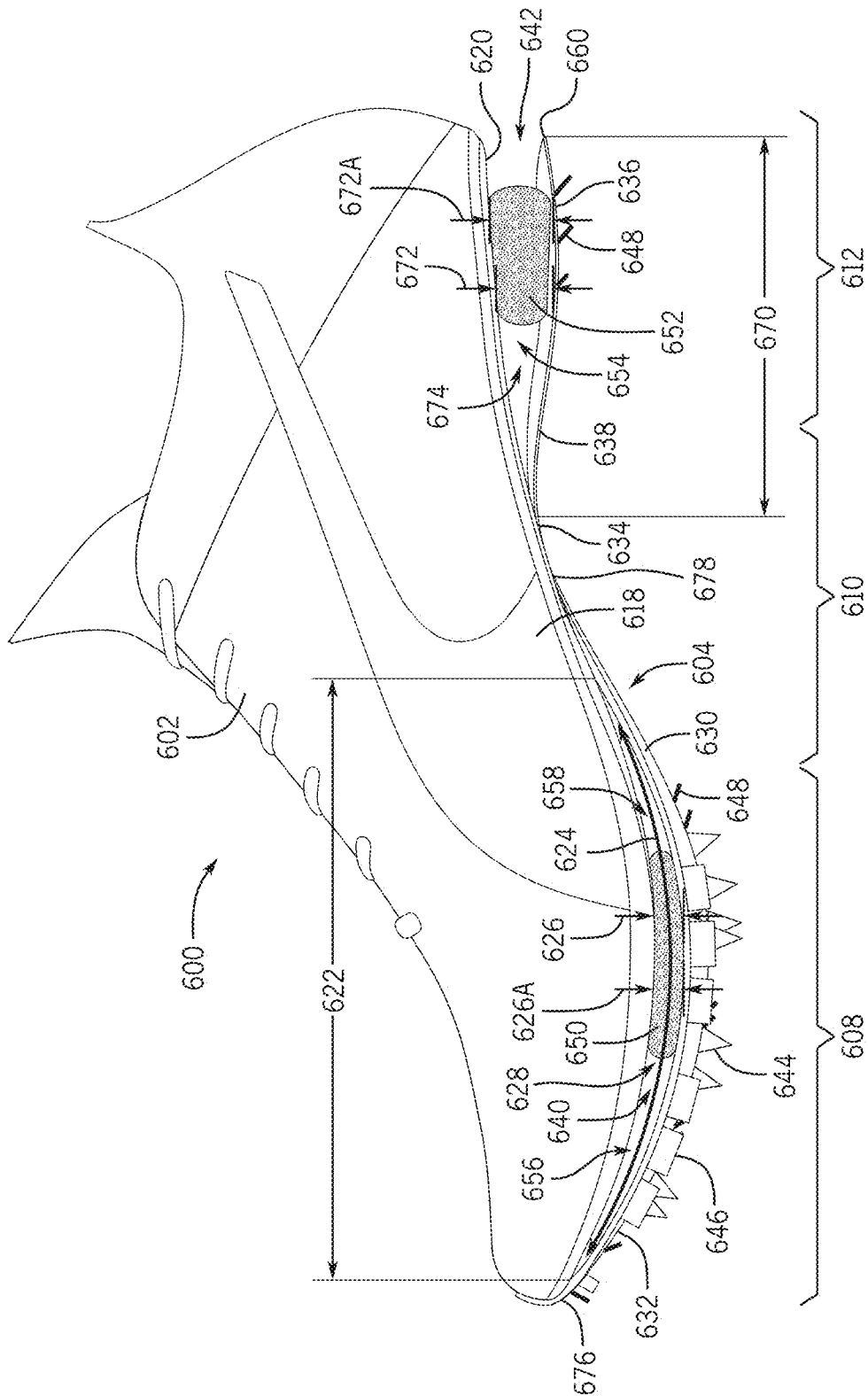

FIG. 16

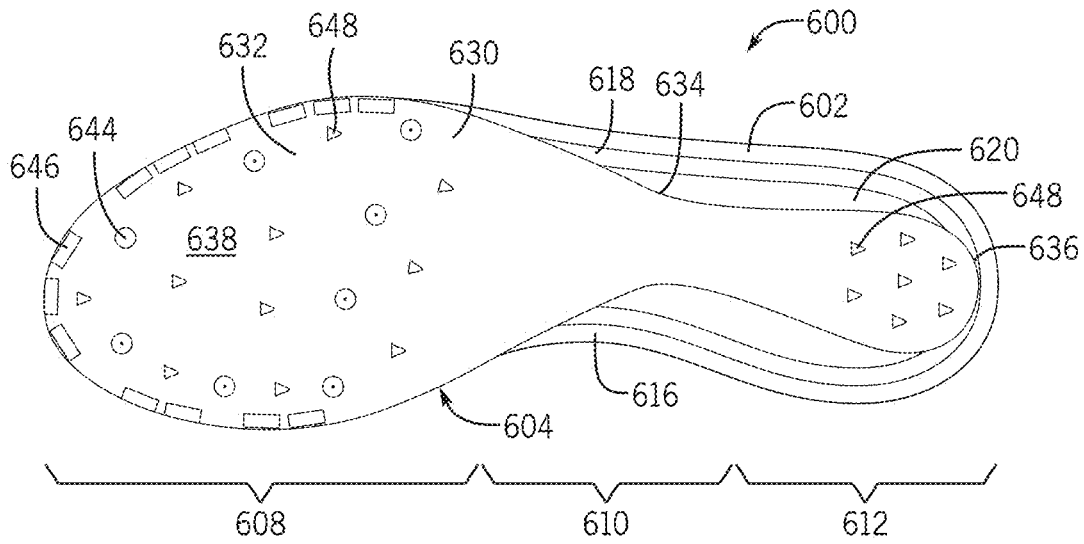

FIG. 17

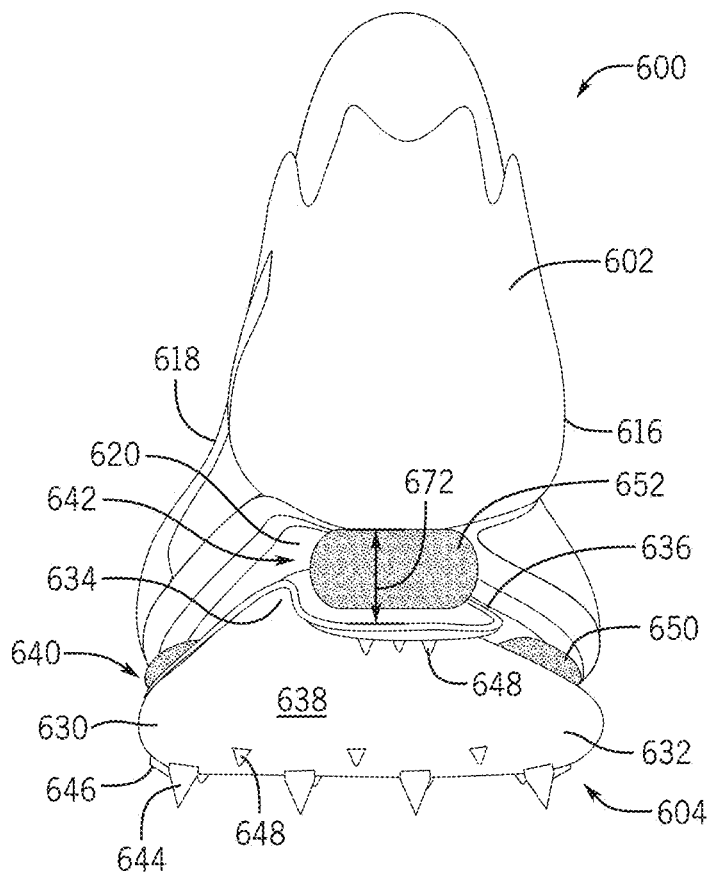
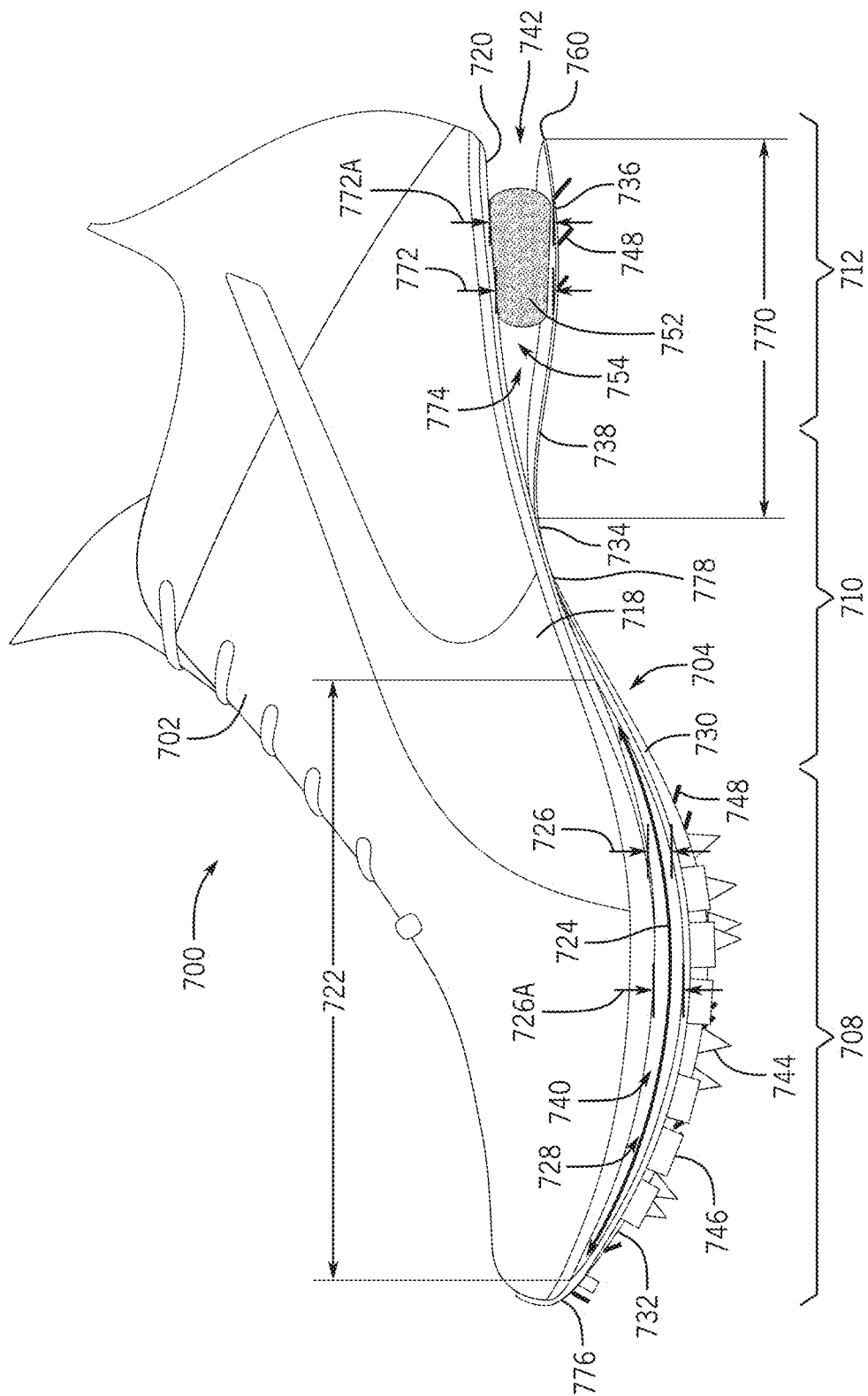

FIG. 18



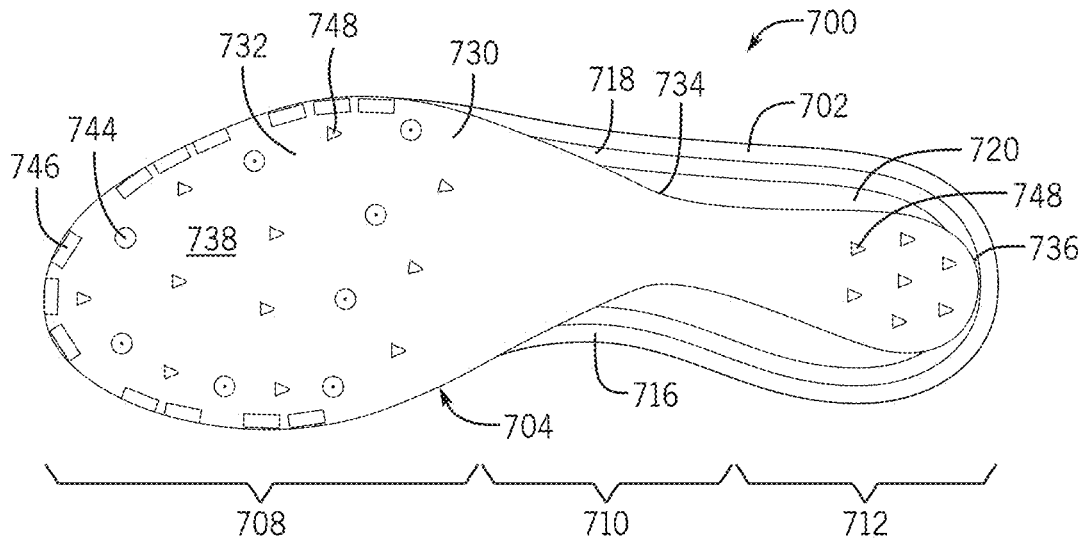

FIG. 20

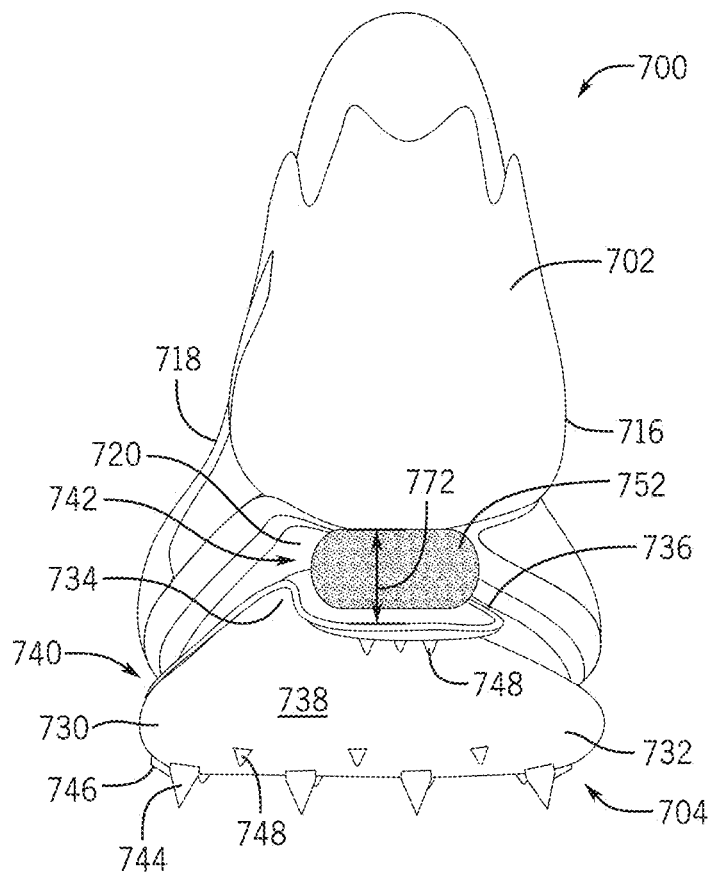

FIG. 21

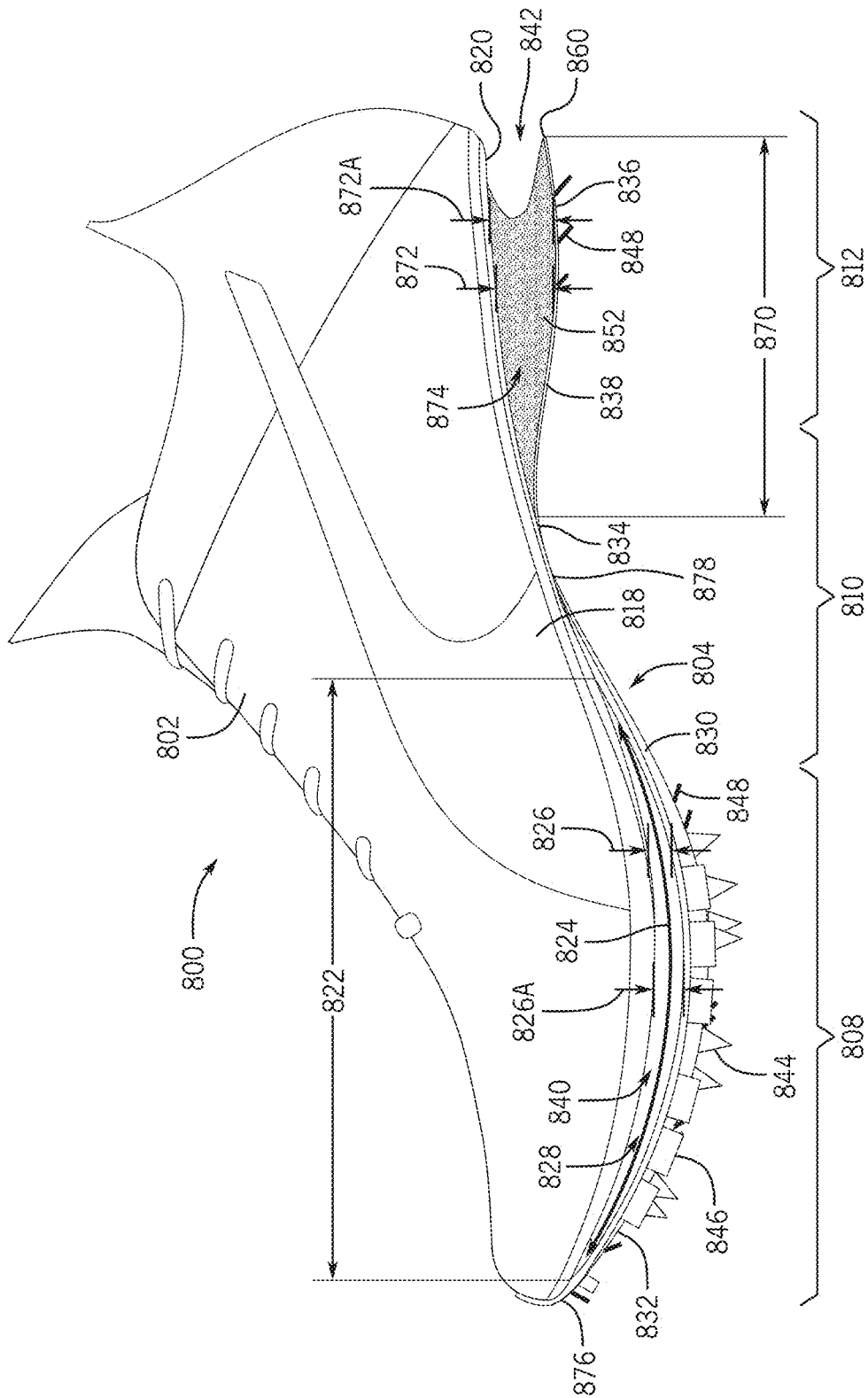

FIG. 22

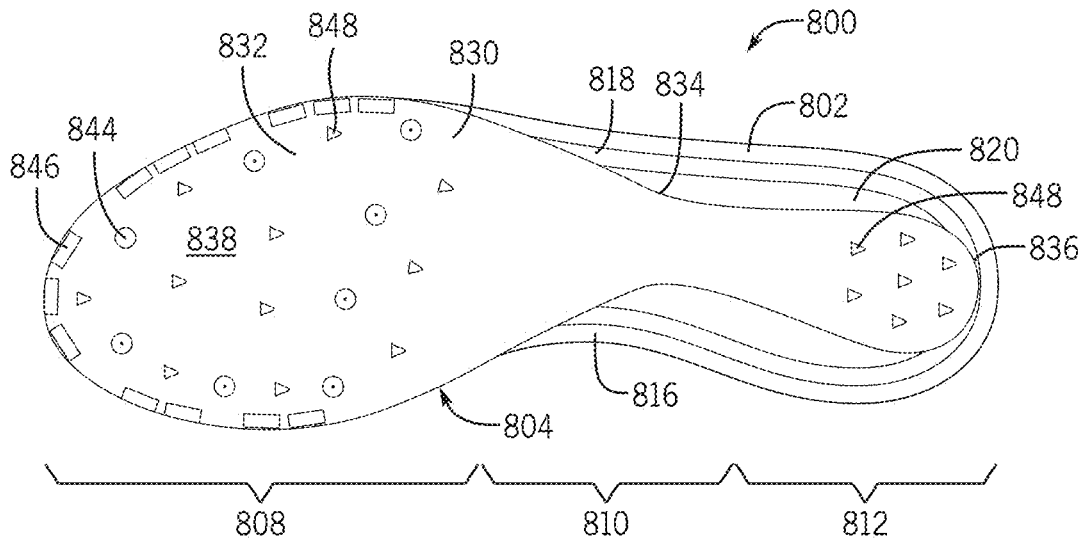

FIG. 23

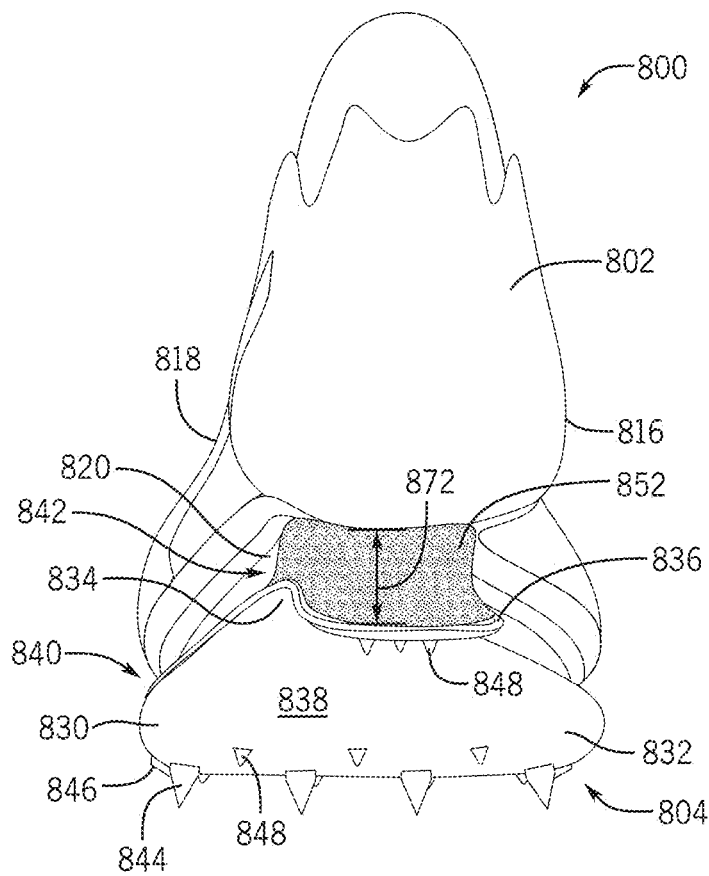

FIG. 24

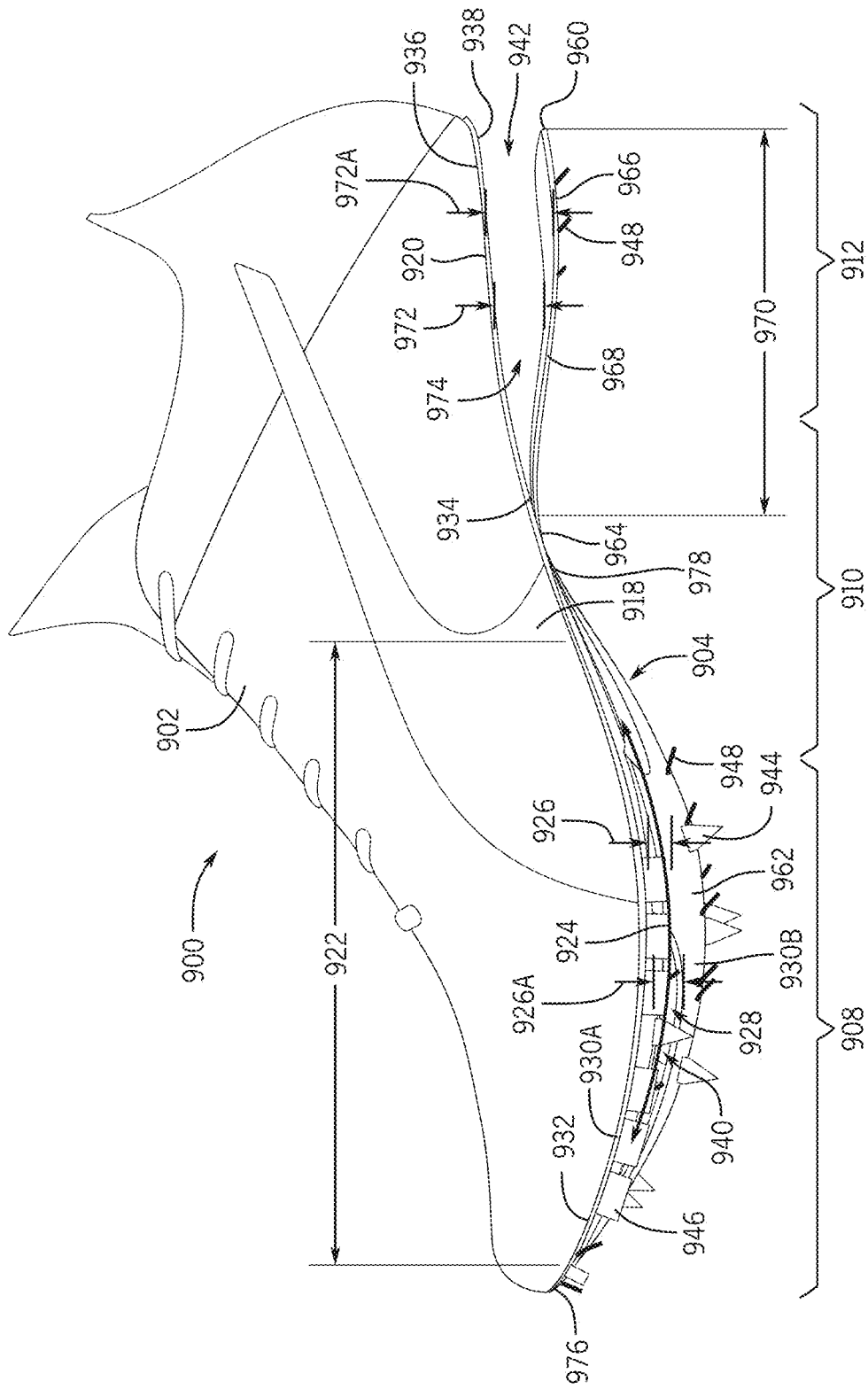

FIG. 25

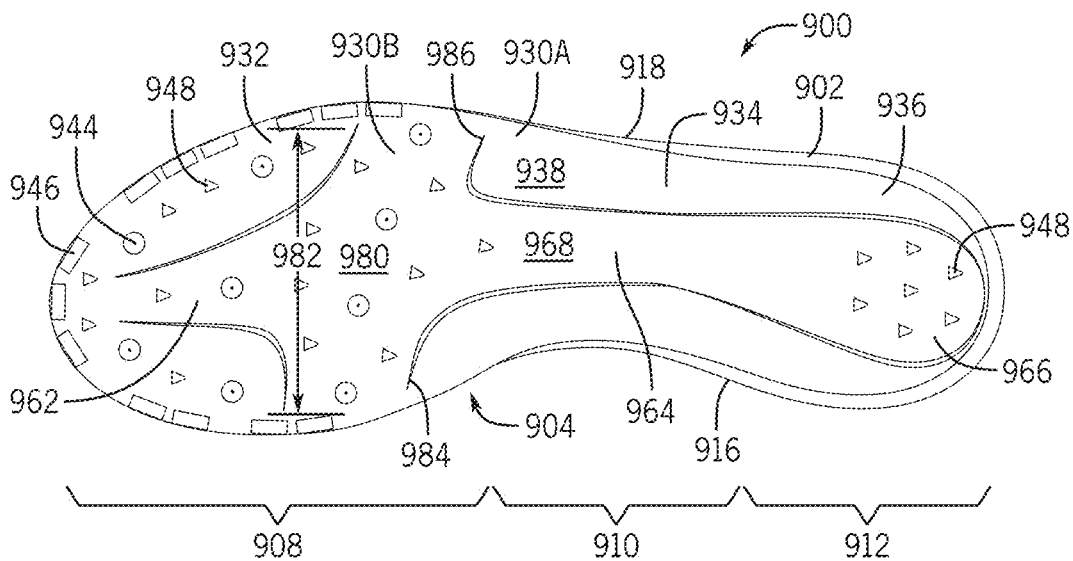

FIG. 26

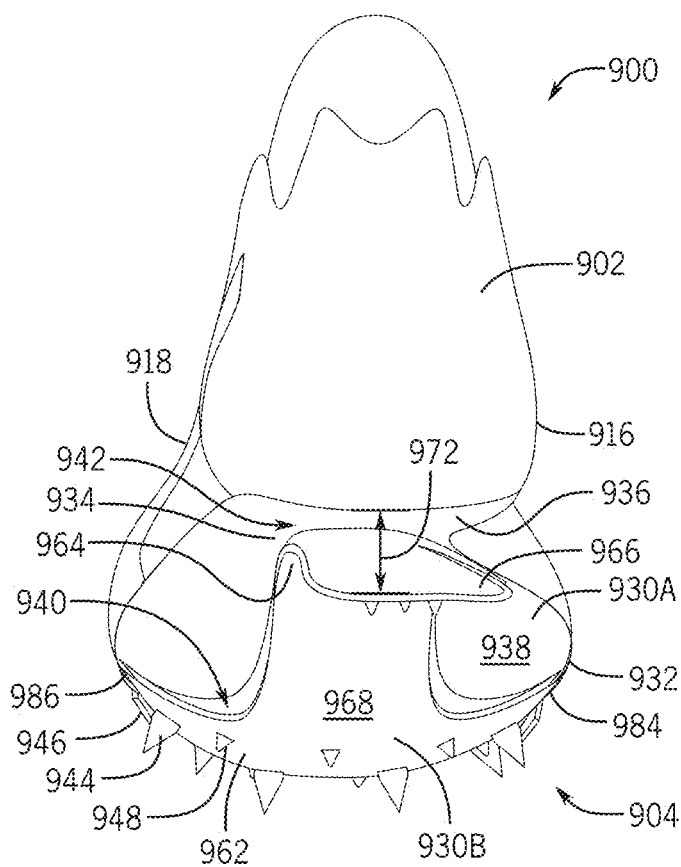

FIG. 27

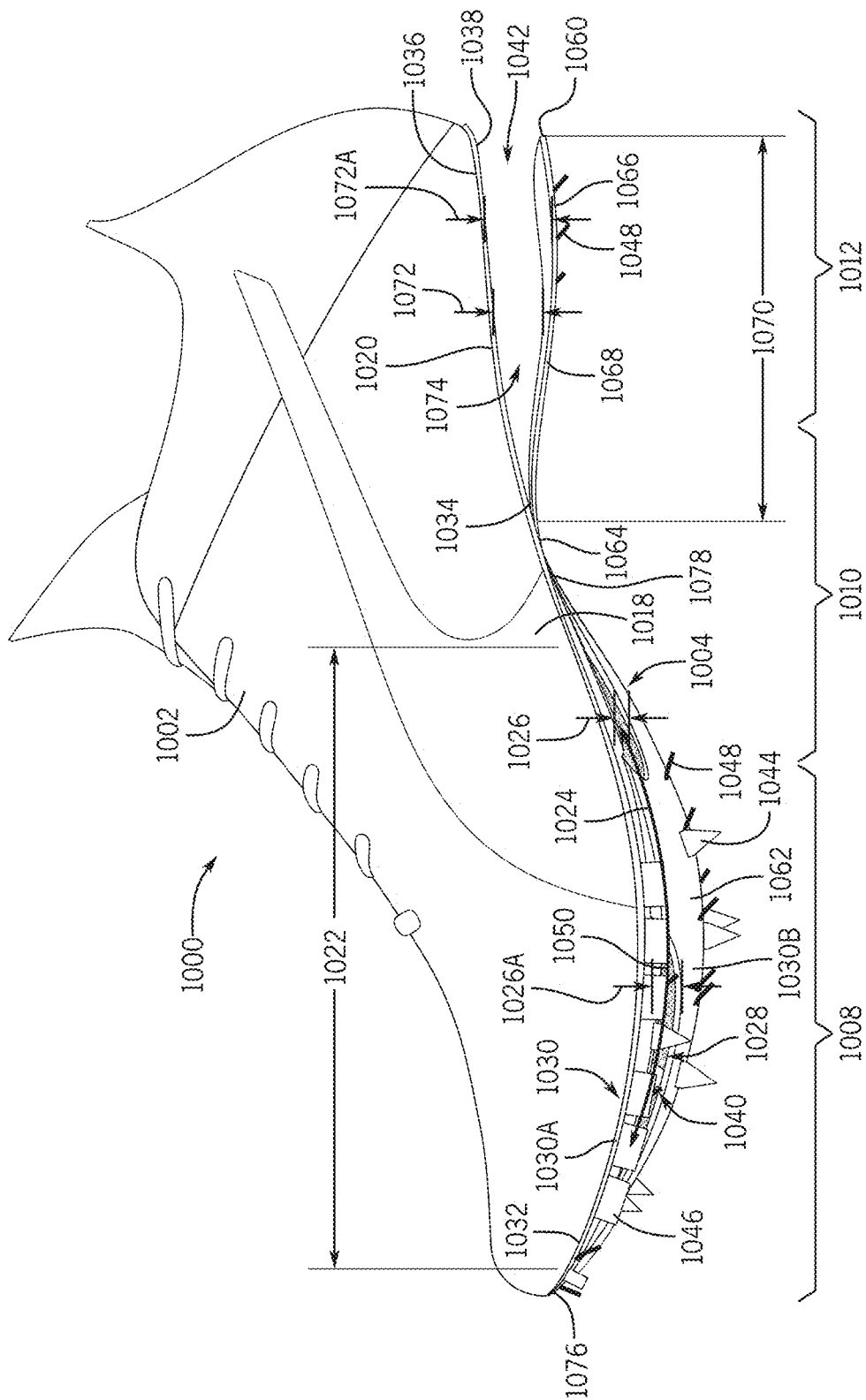

FIG. 28

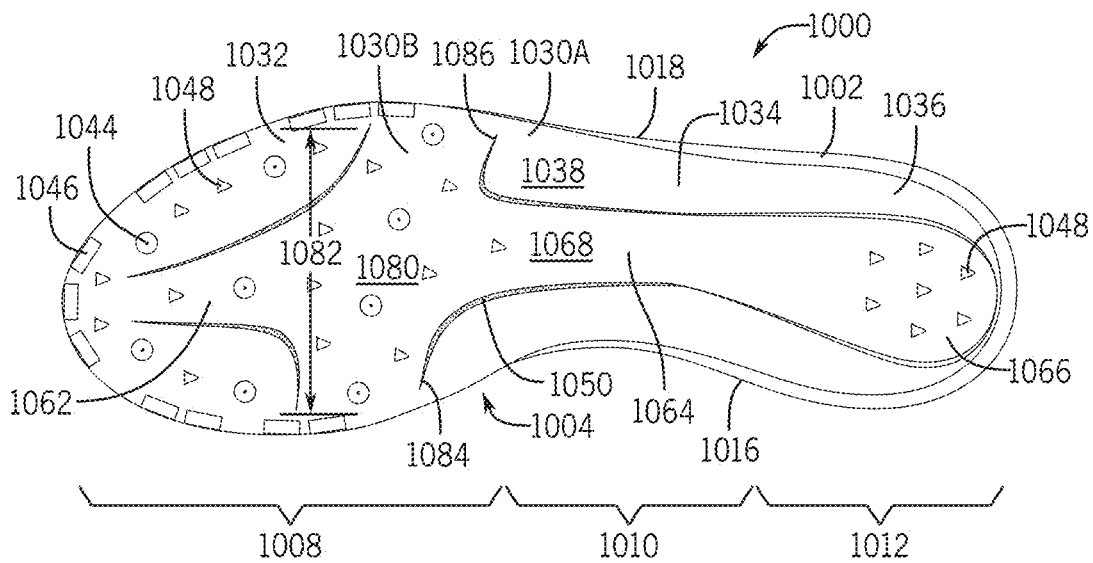

FIG. 29

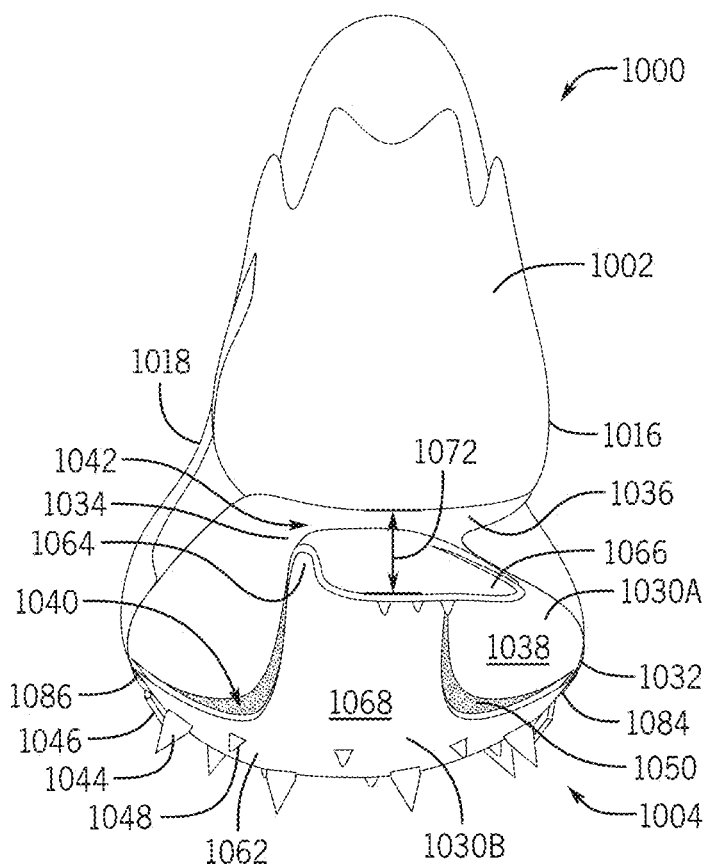

FIG. 30

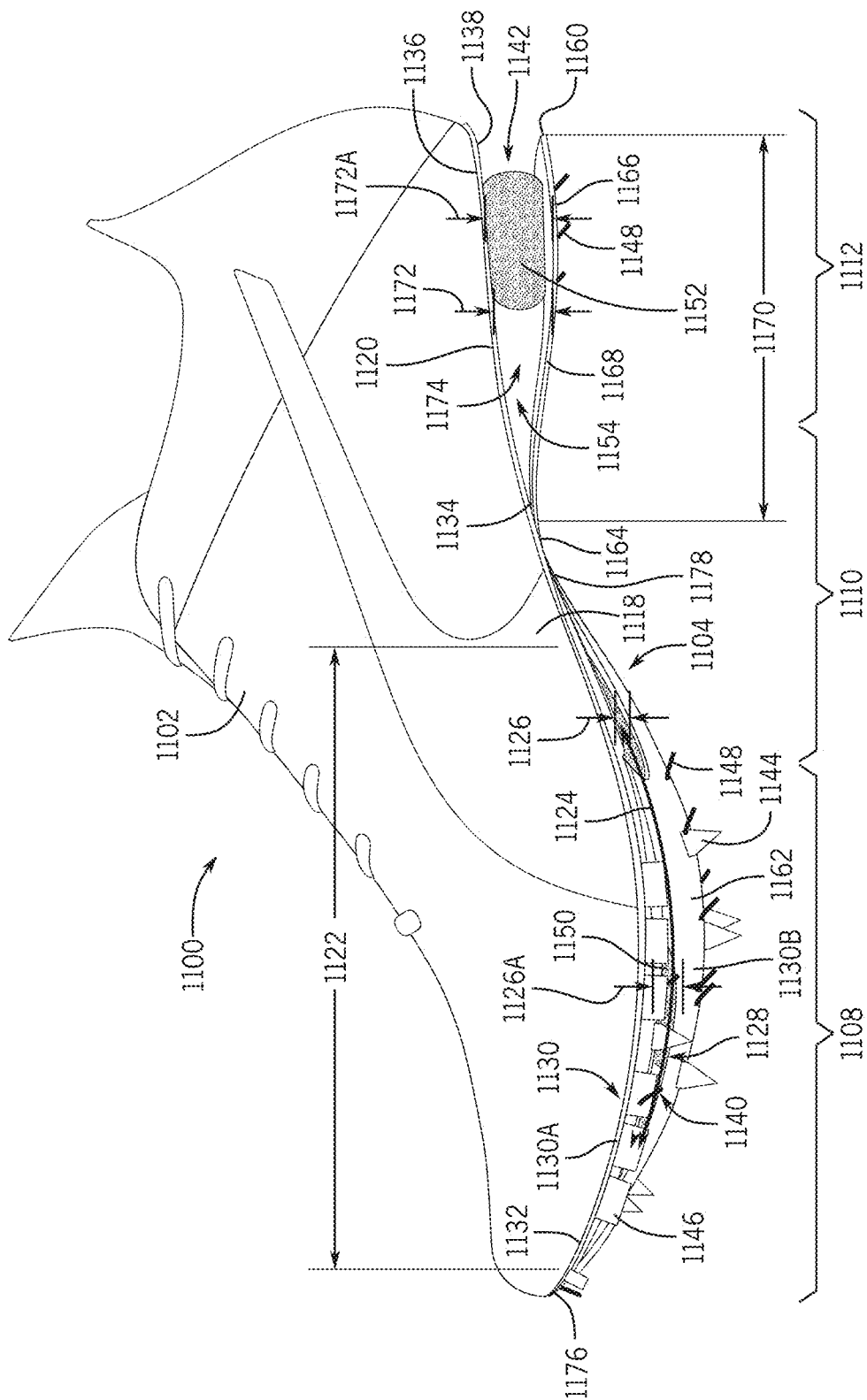

FIG. 31

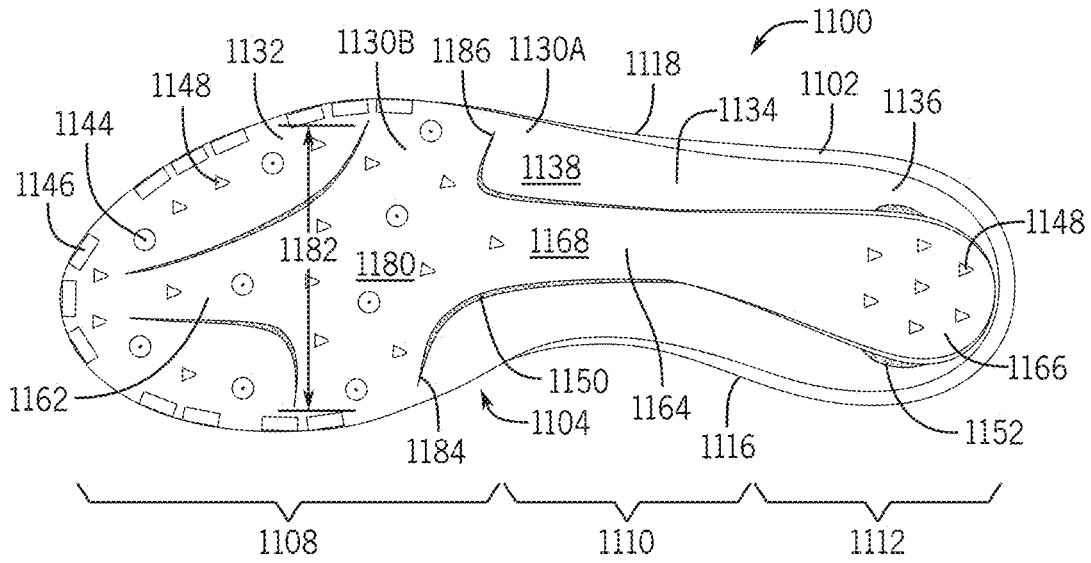

FIG. 32

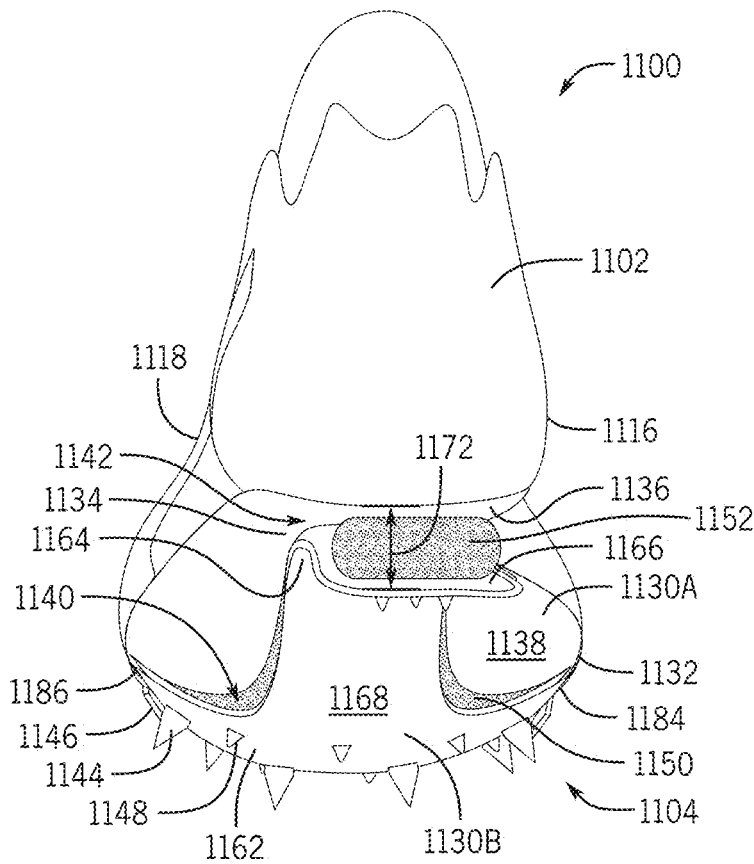

FIG. 33

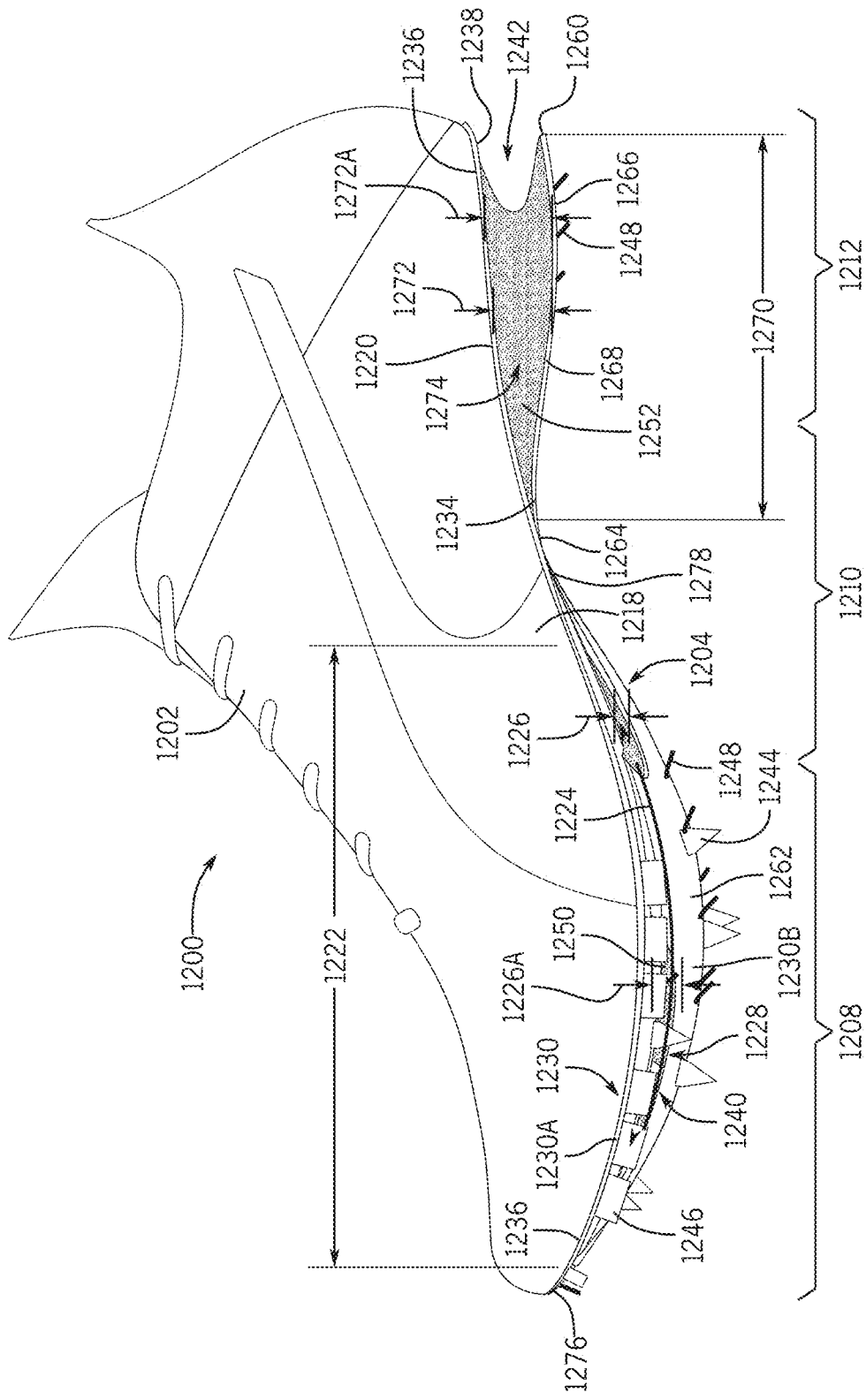

FIG. 34

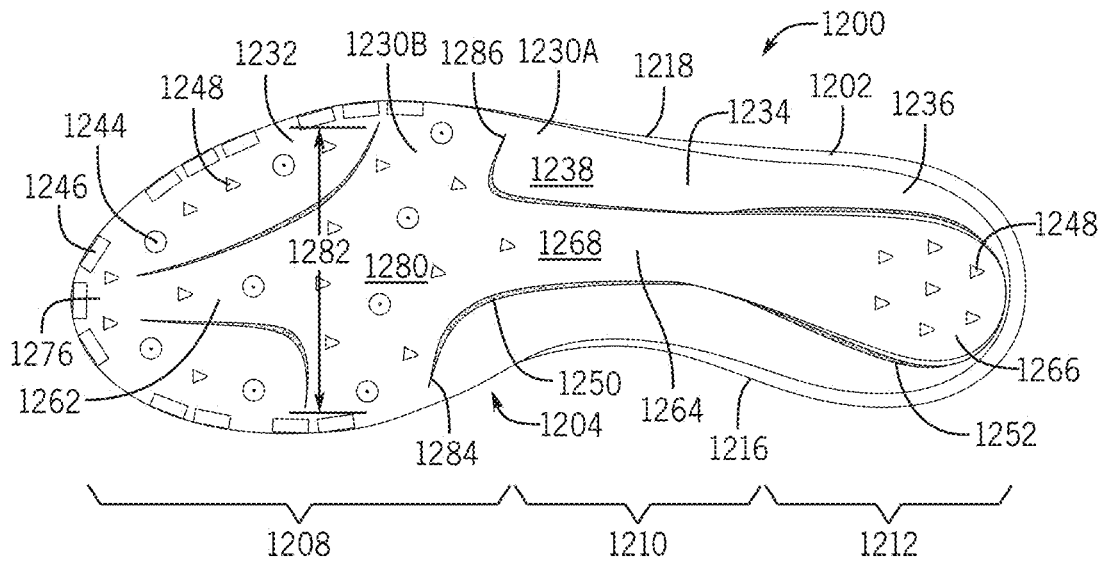

FIG. 35

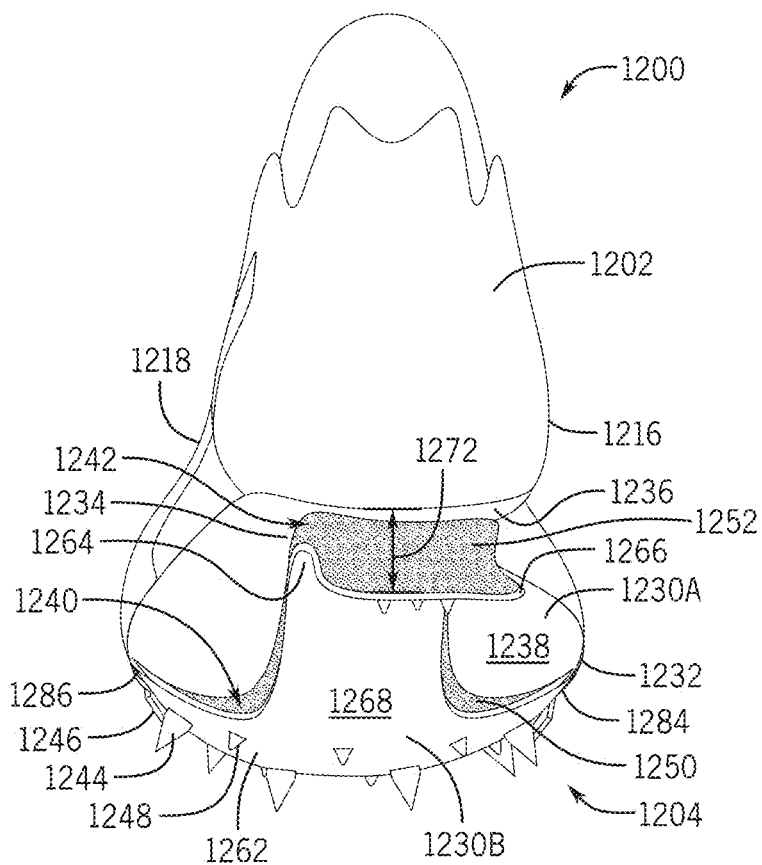

FIG. 36

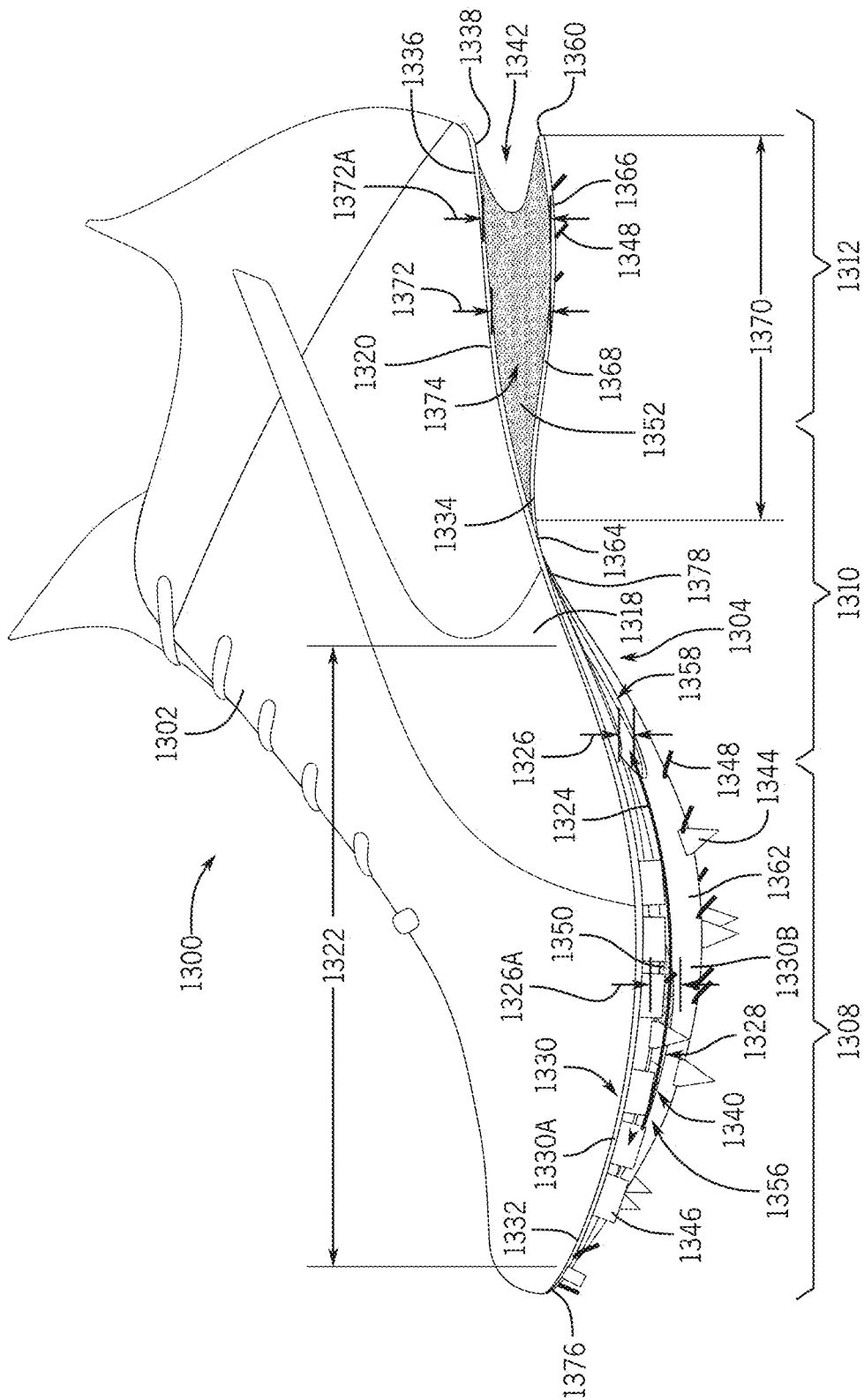

FIG. 37

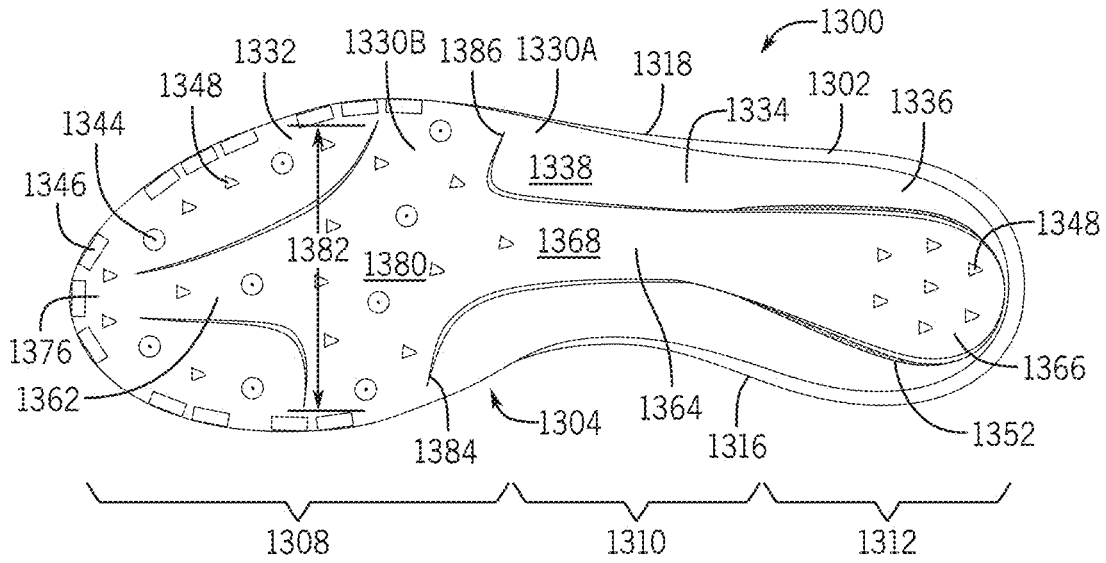

FIG. 38

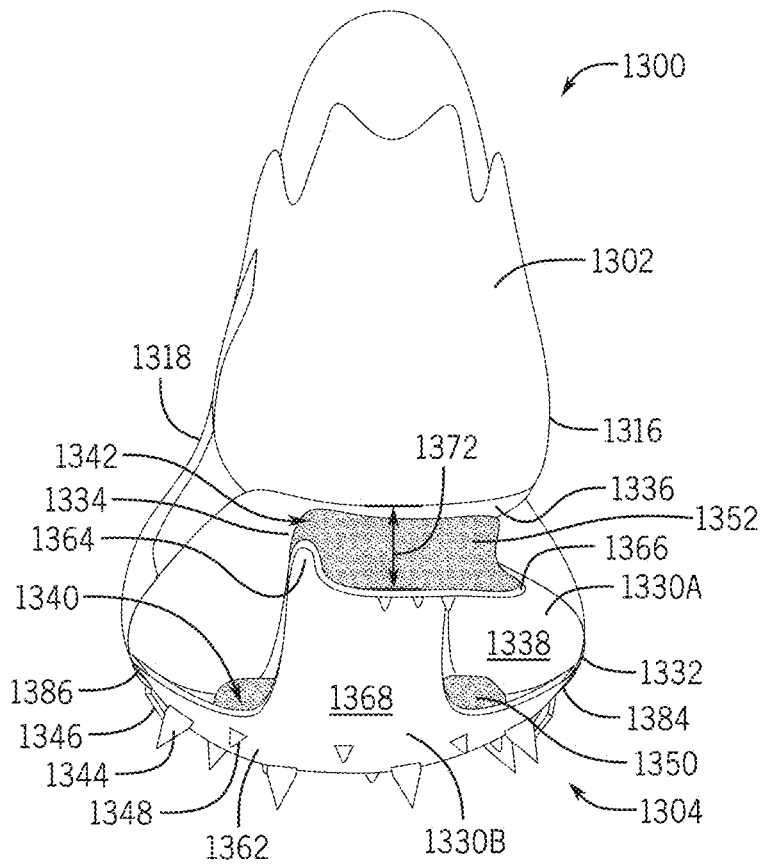

FIG. 39

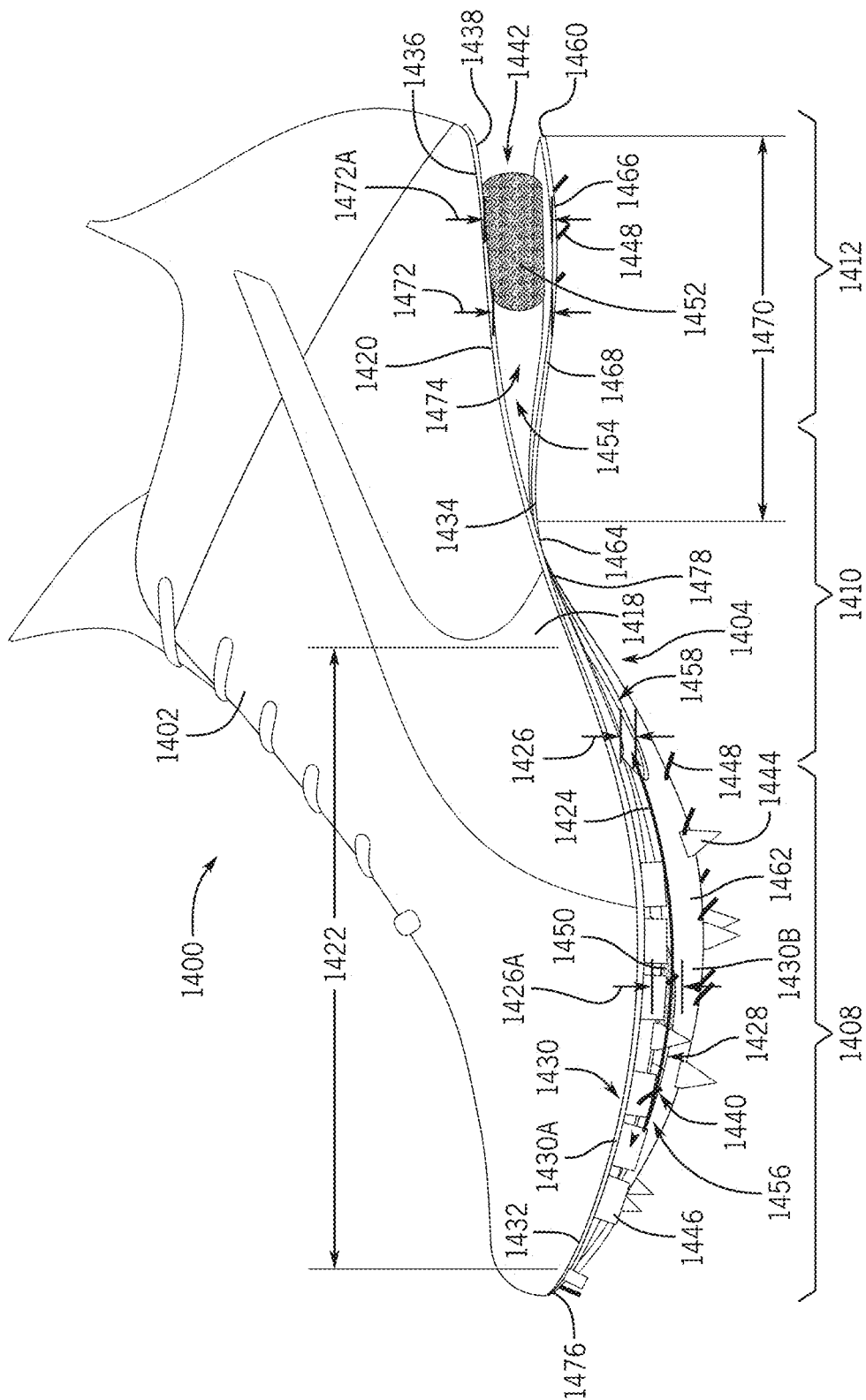

FIG. 40

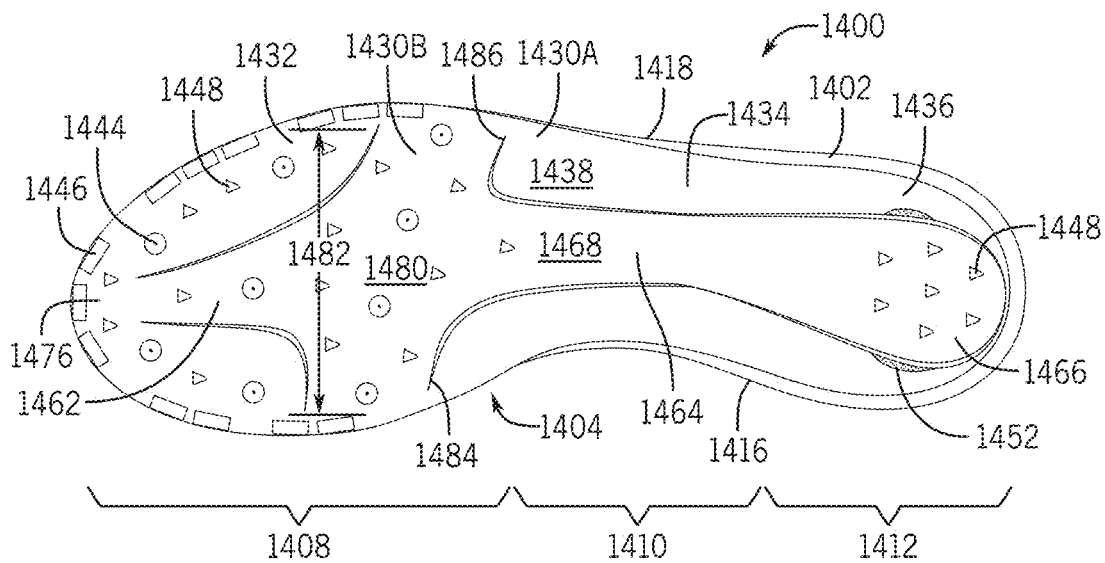

FIG. 41

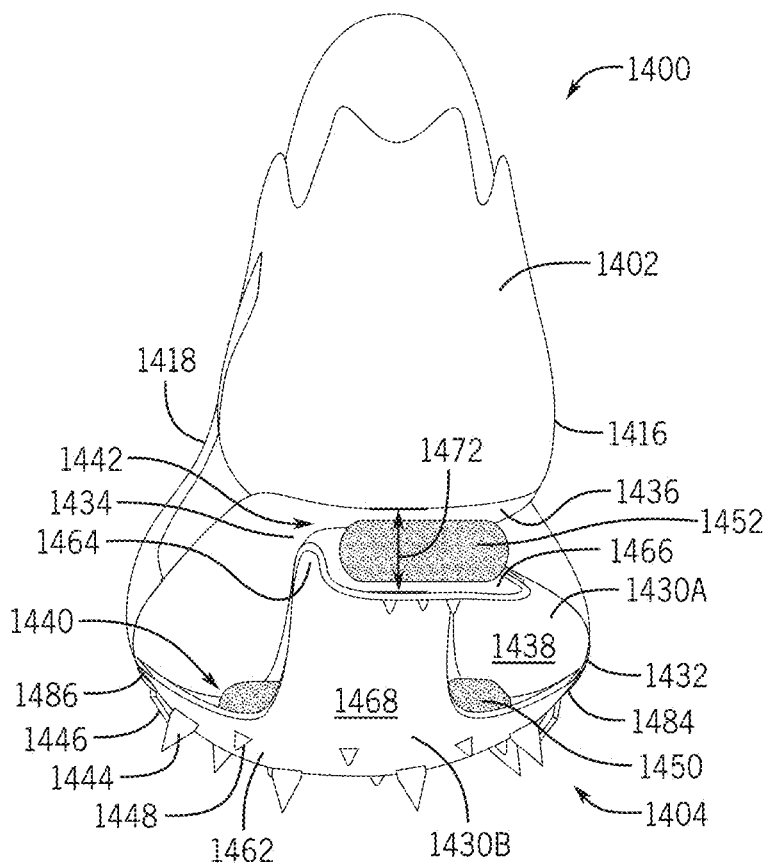

FIG. 42

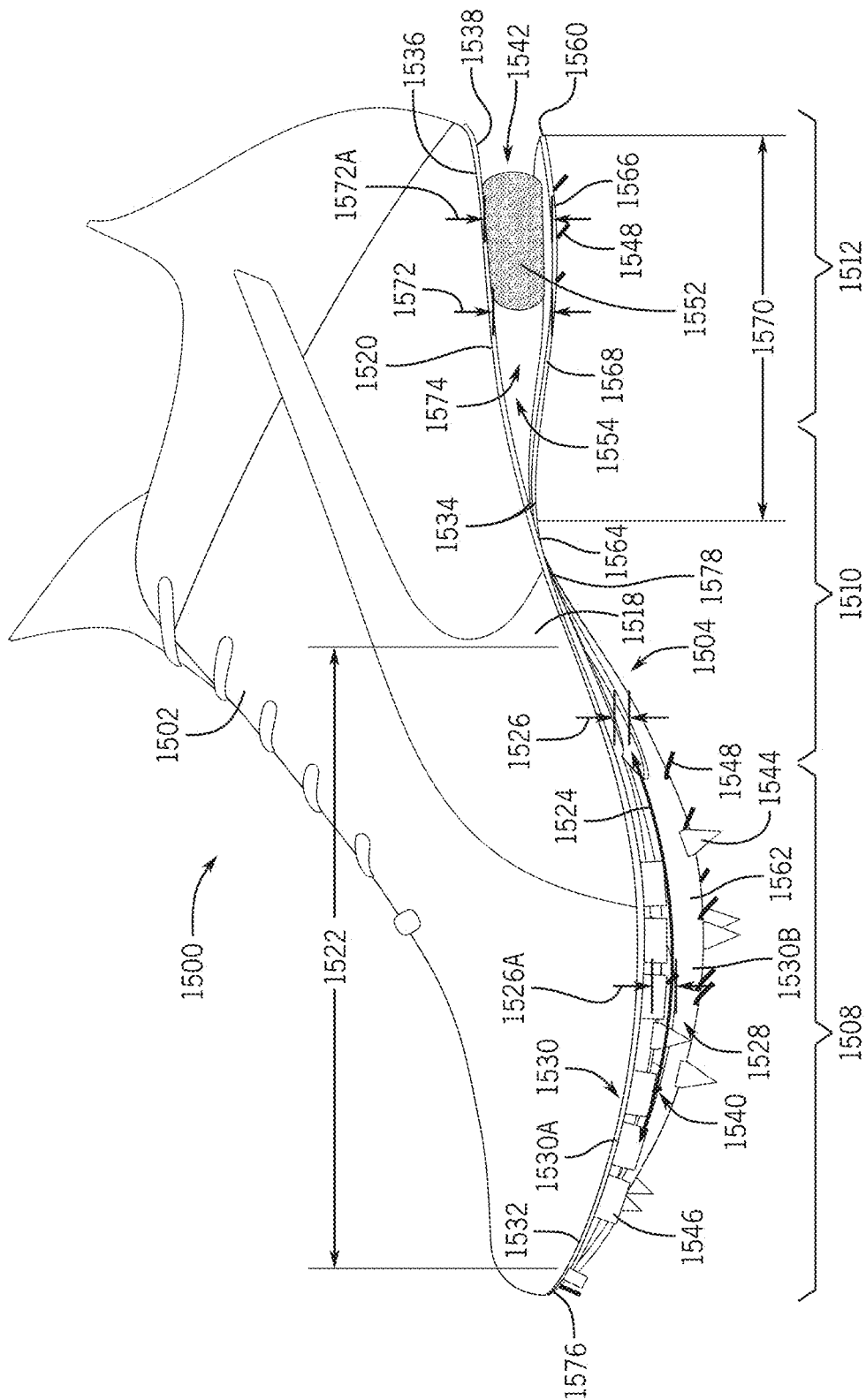

FIG. 43

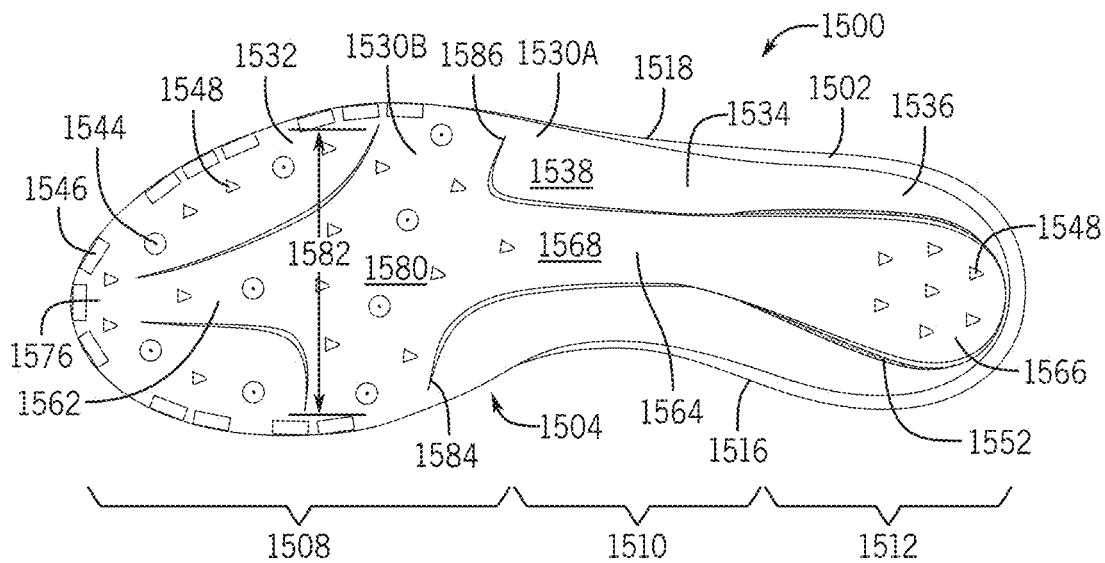

FIG. 44

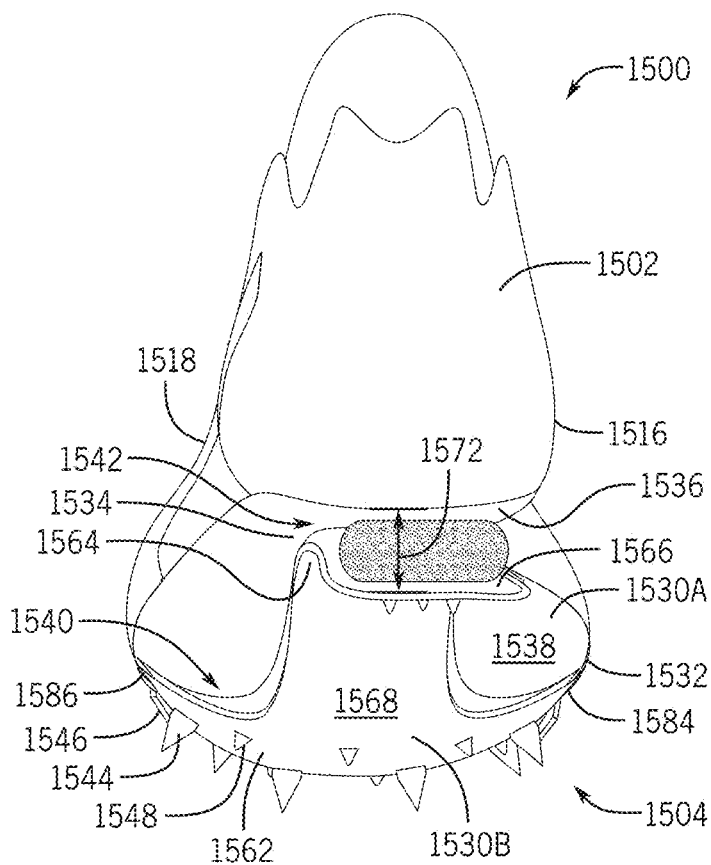

FIG. 45

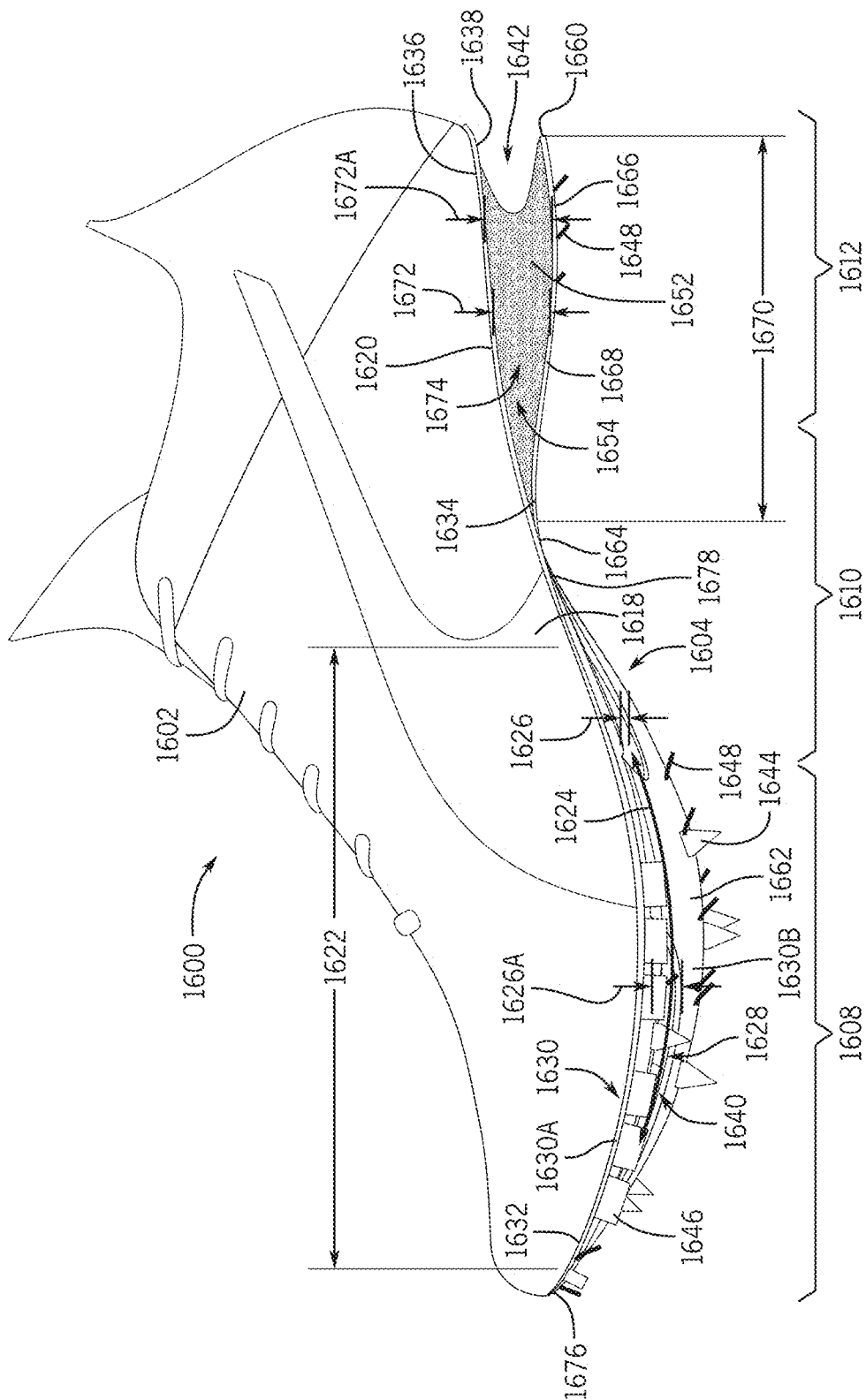

FIG. 46

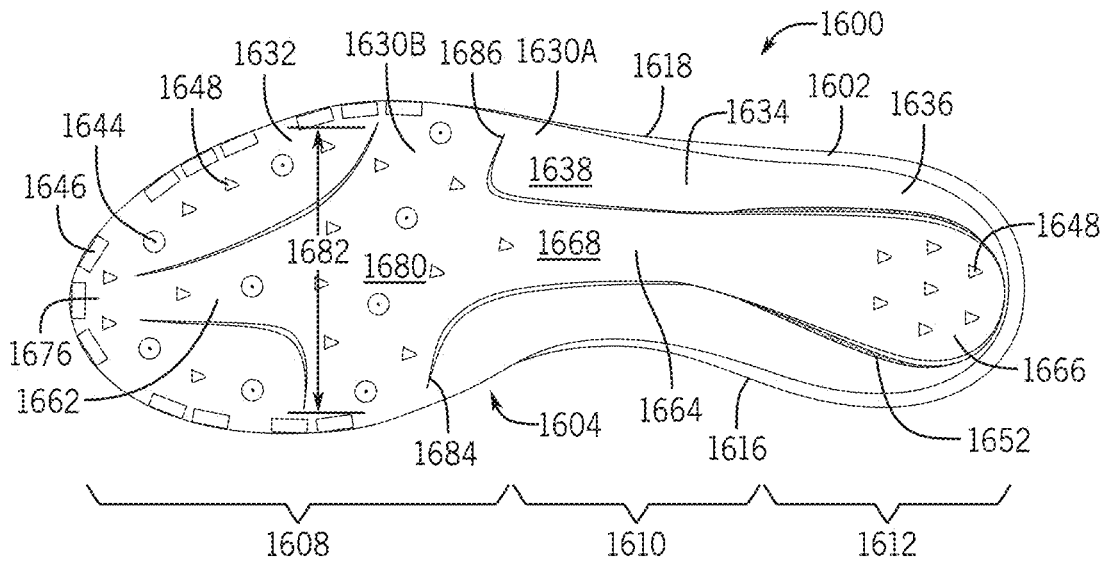

FIG. 47

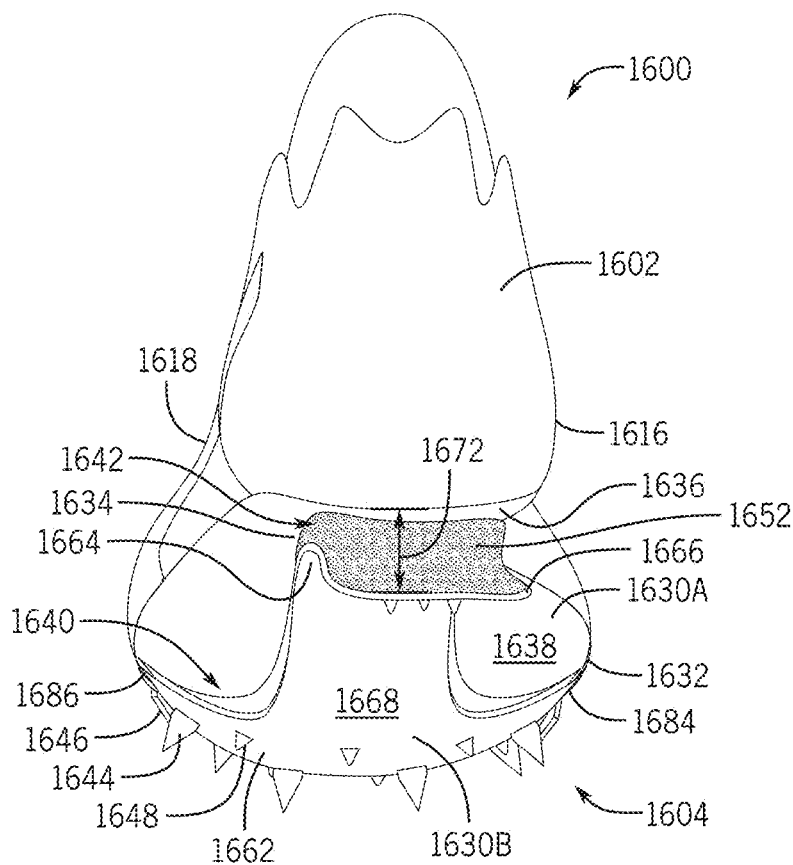

FIG. 48

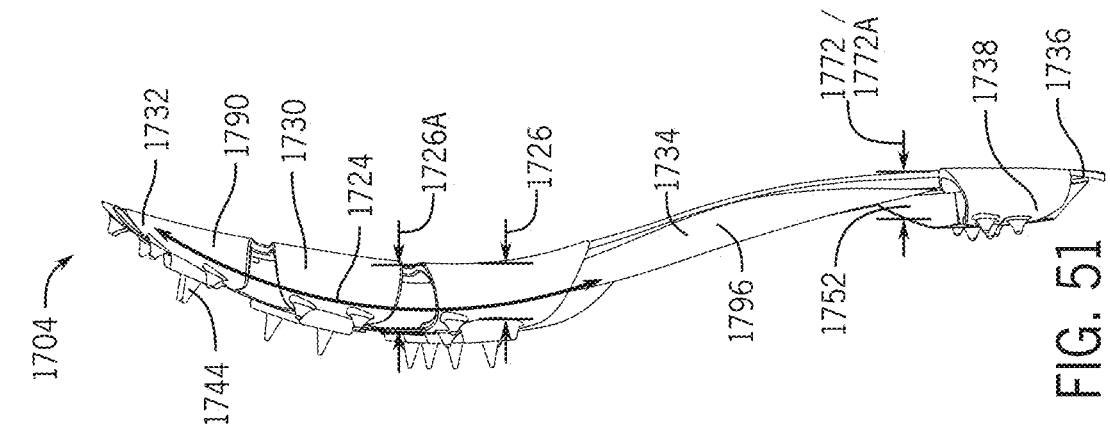

FIG. 49

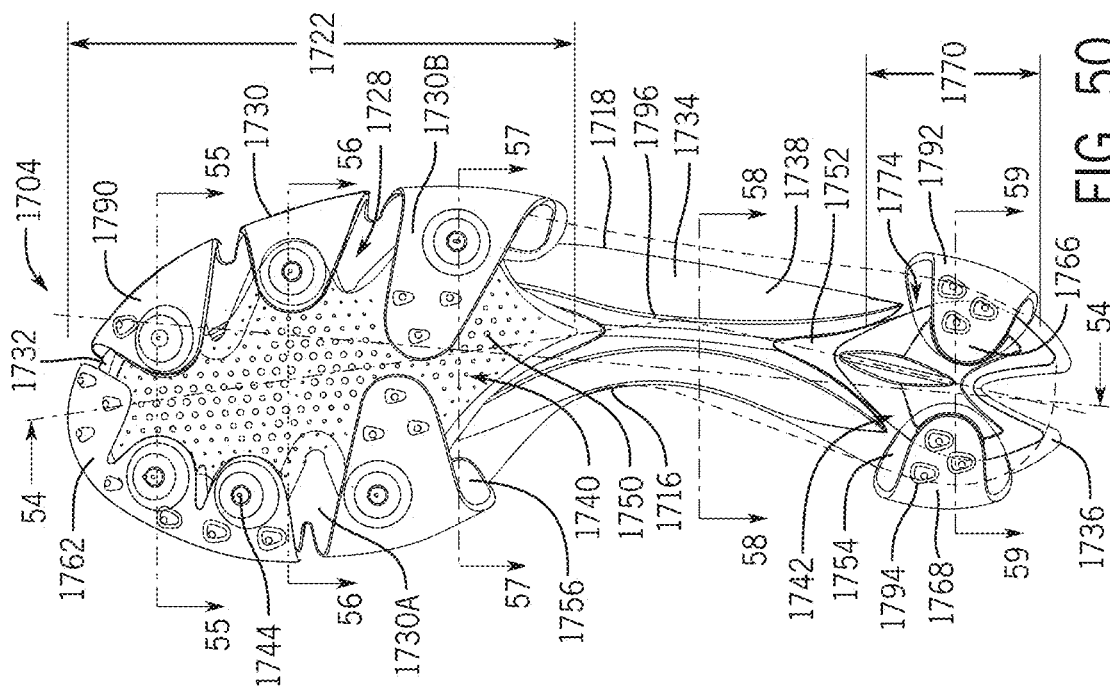

FIG. 50

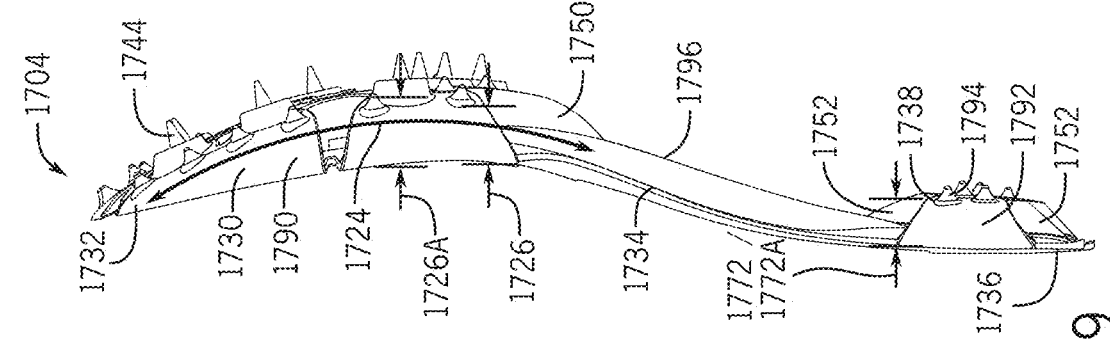

FIG. 51

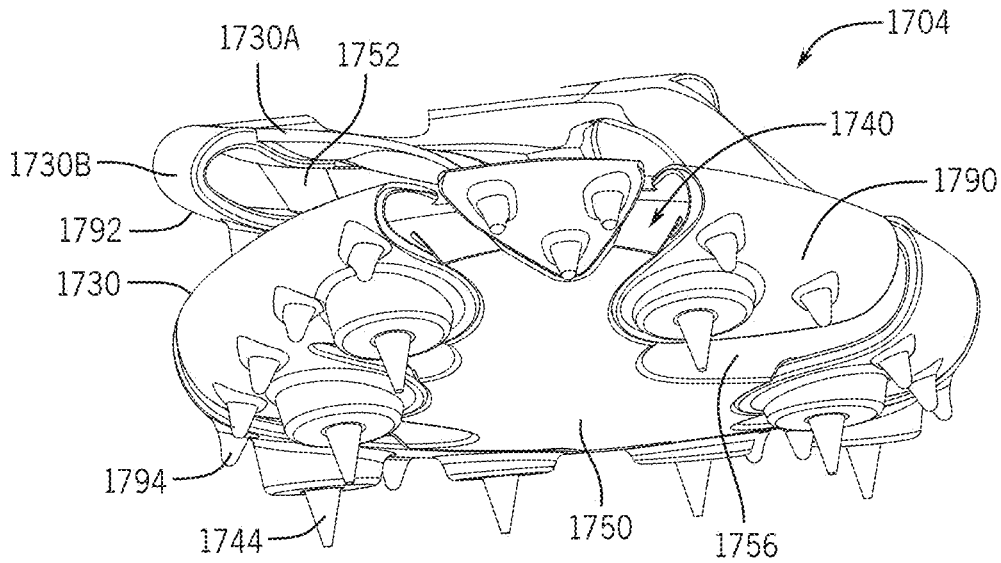

FIG. 52

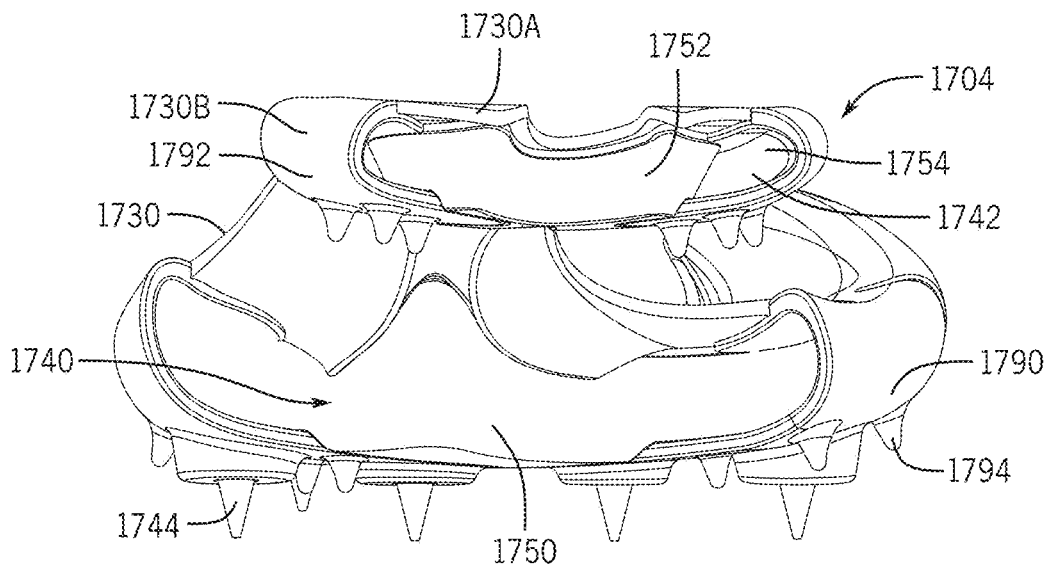

FIG. 53

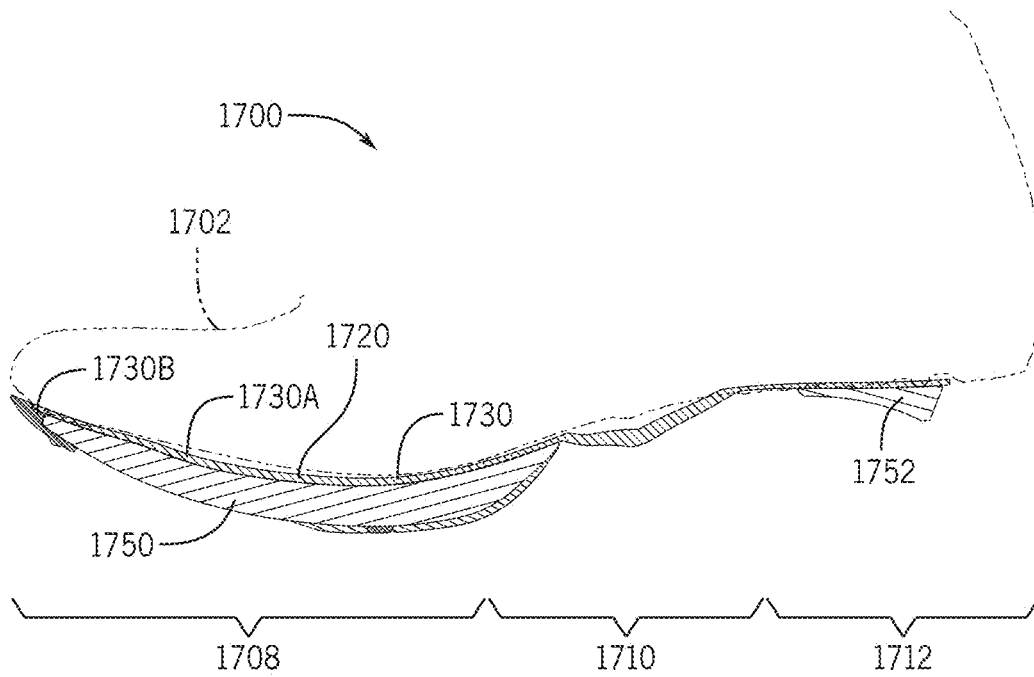

FIG. 54

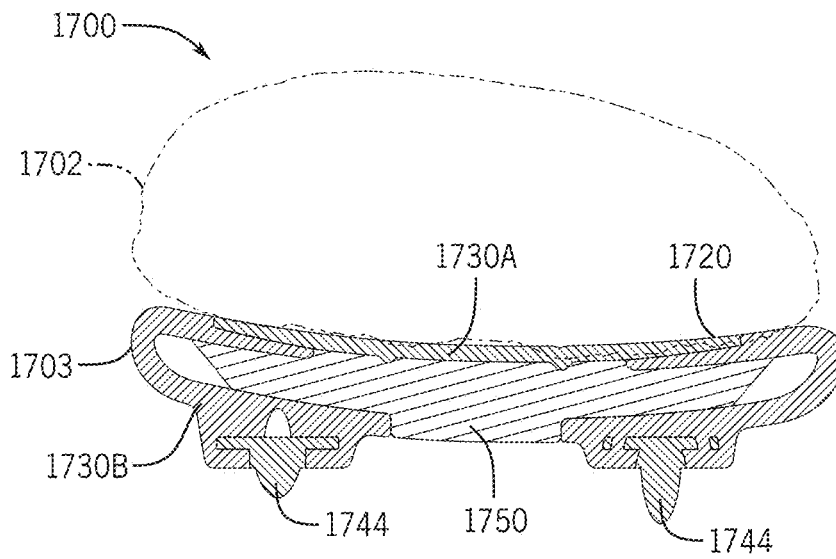
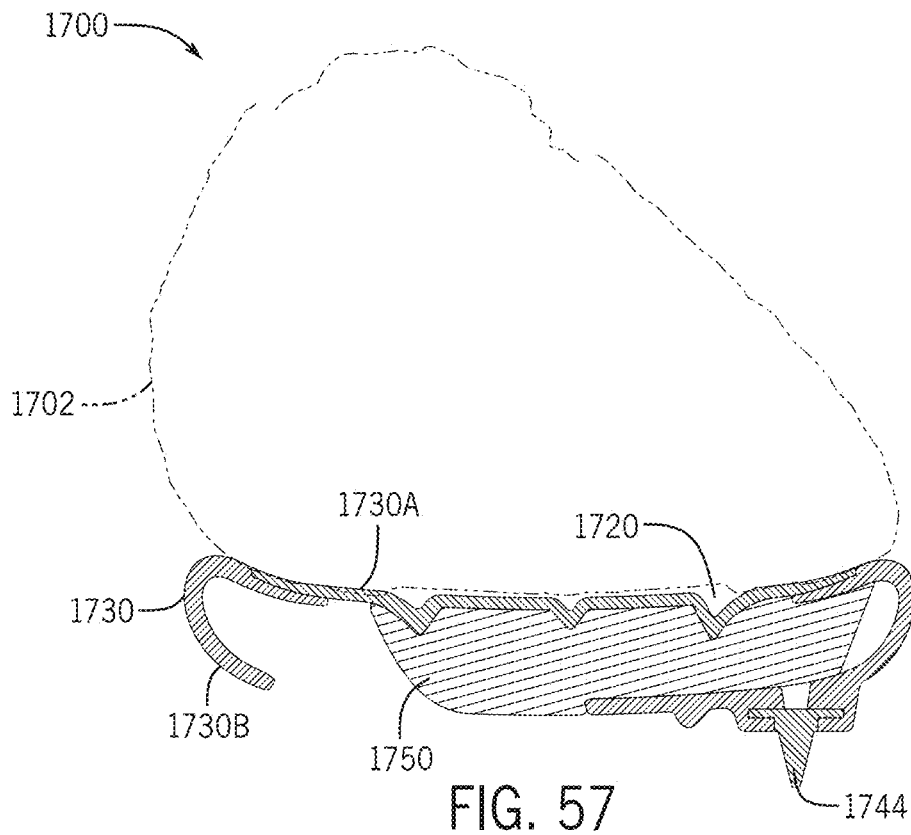
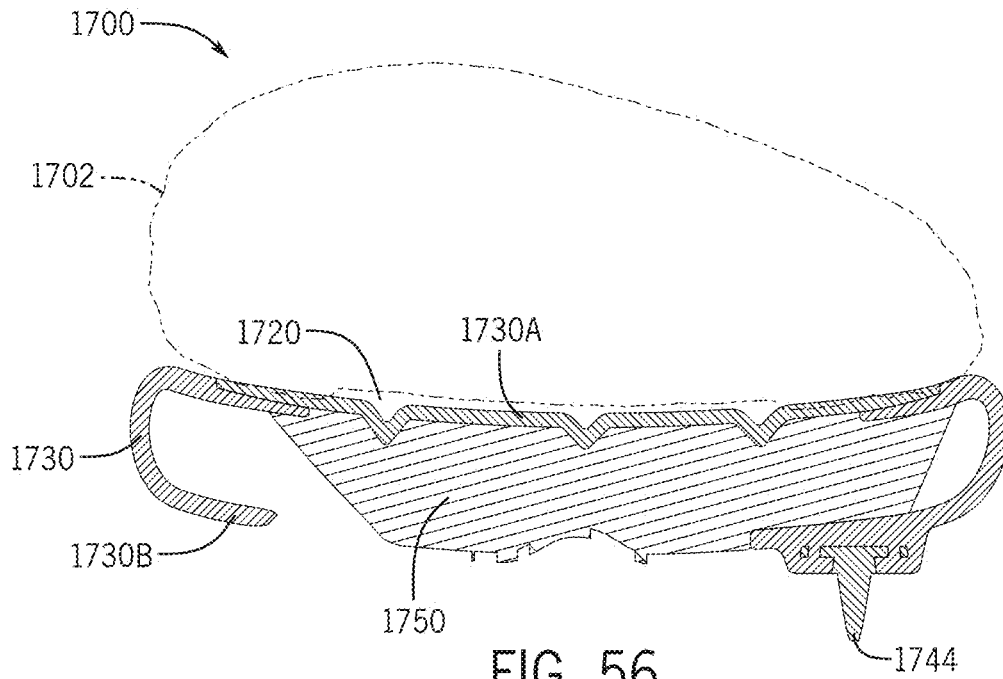

FIG. 55



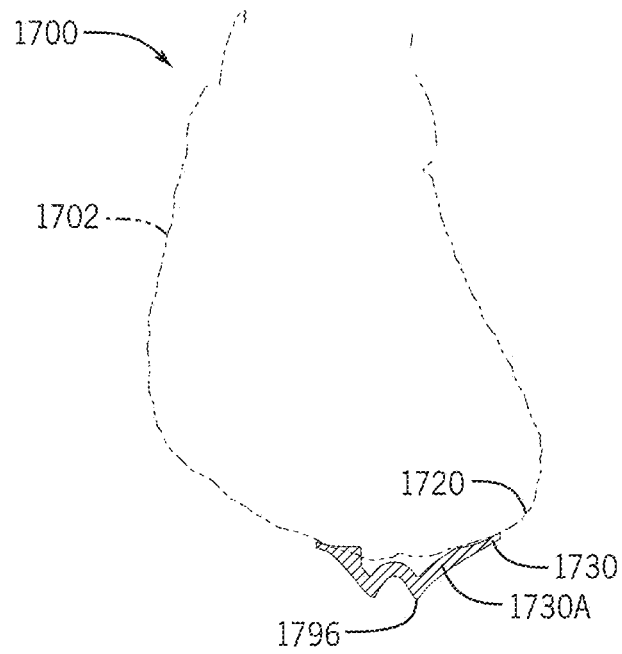

FIG. 58

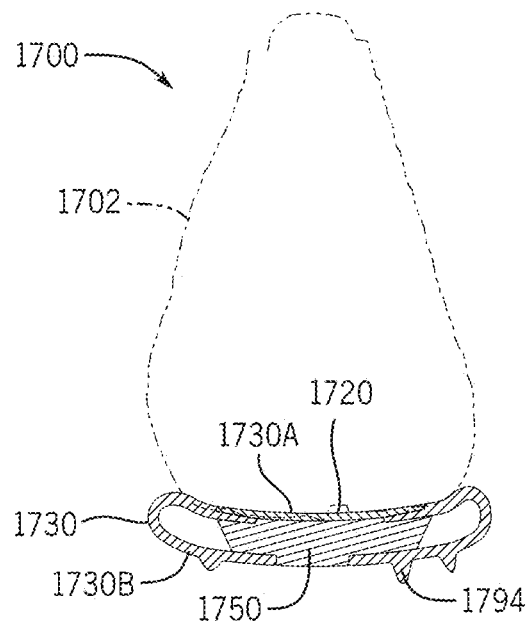

FIG. 59

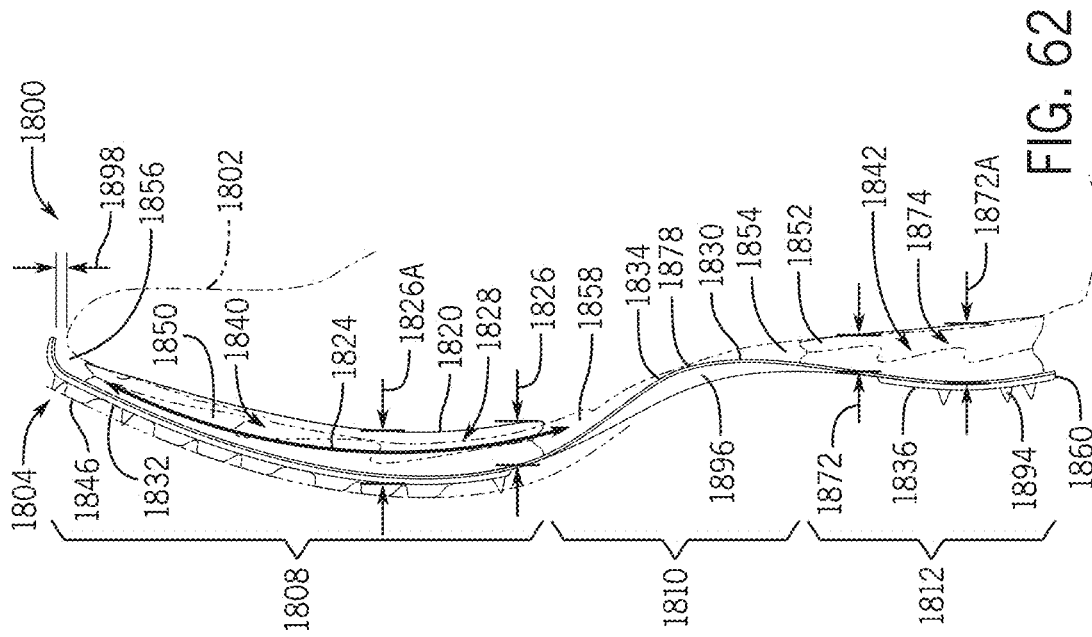

FIG. 62

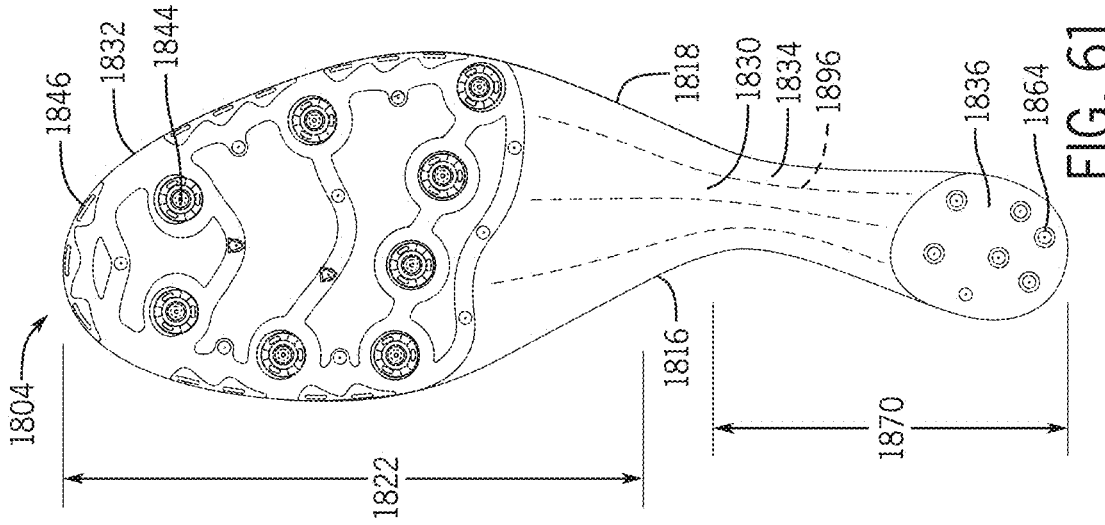

FIG. 61

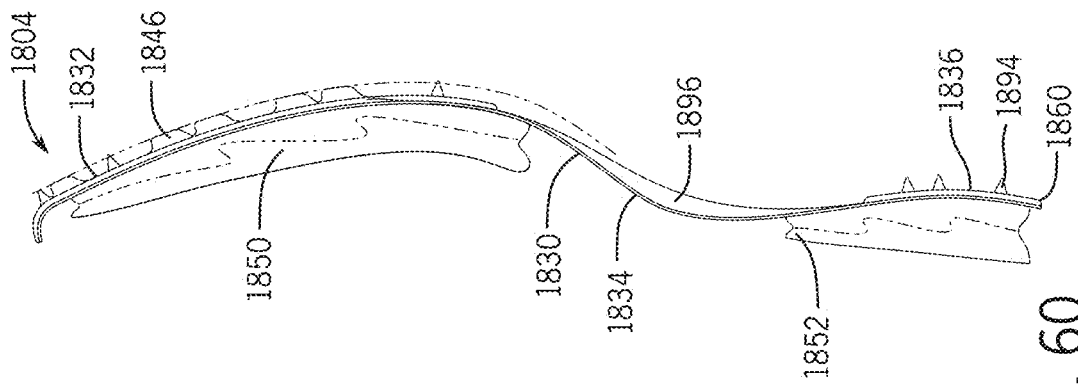
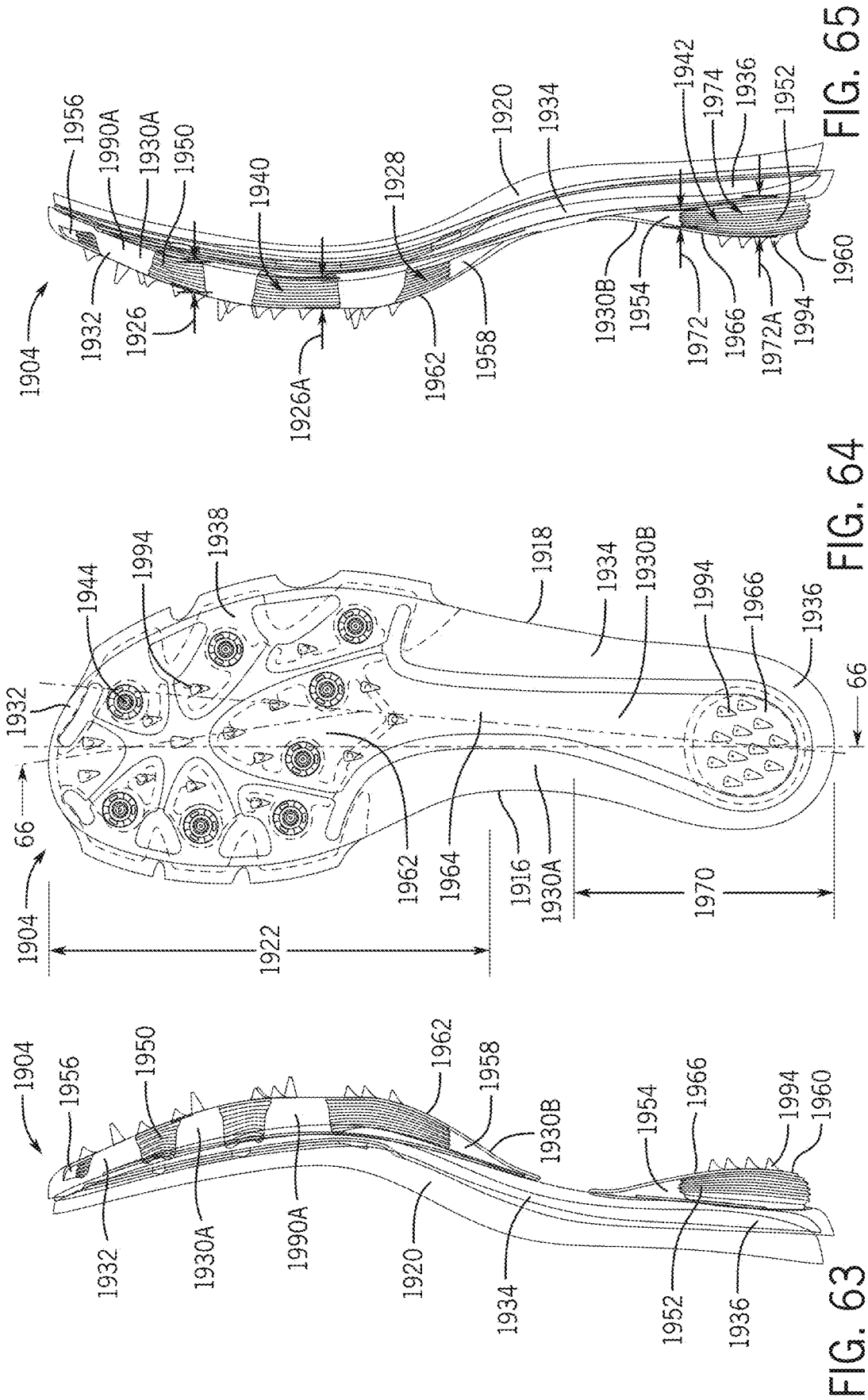

FIG. 60



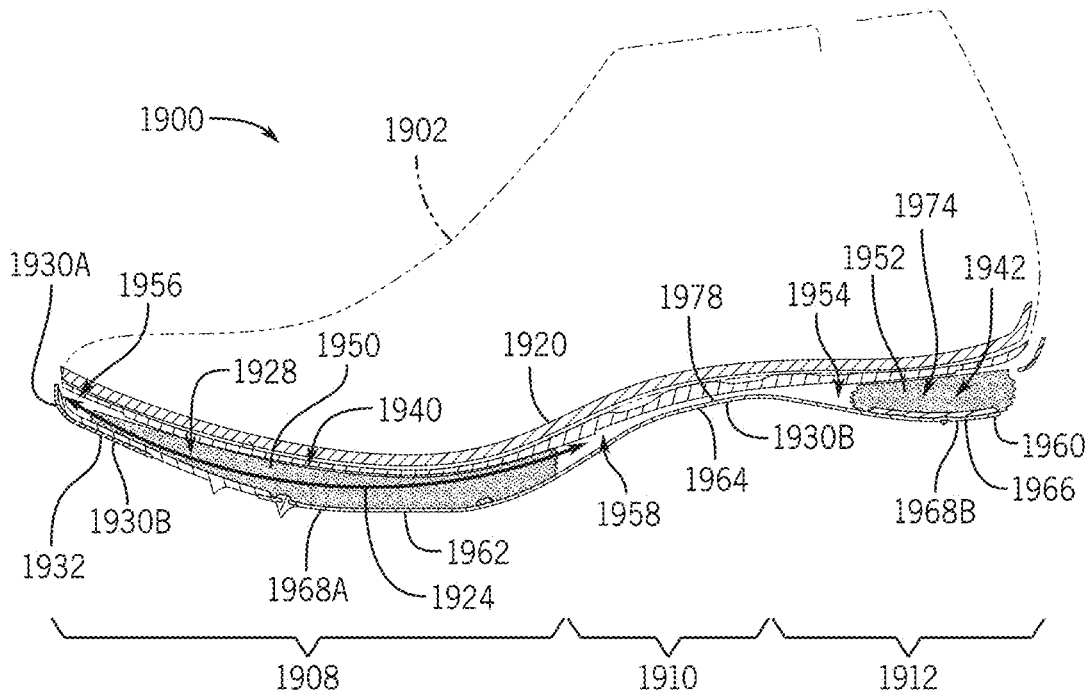

FIG. 66

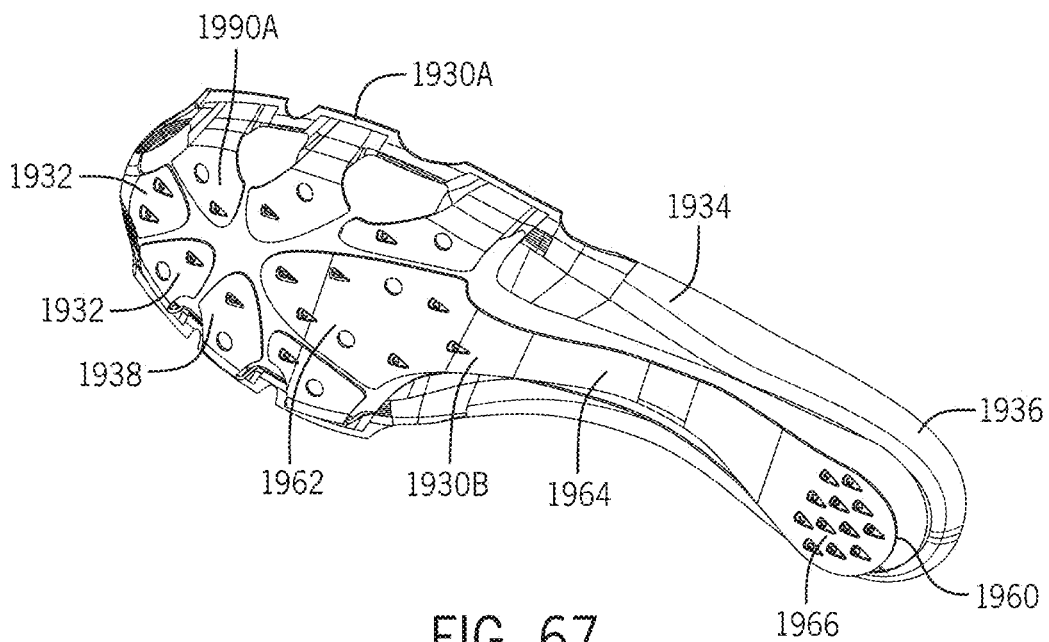

FIG. 67

US 11,974,630 B2

1

**ARTICLE OF FOOTWEAR HAVING A SOLE
PLATE****CROSS REFERENCE TO RELATED
APPLICATIONS**

This application is a continuation of U.S. patent application Ser. No. 18/109,991, filed on Feb. 15, 2023, which is a continuation of U.S. patent application Ser. No. 17/218,353, filed on Mar. 31, 2021, which claims priority to U.S. Provisional Application Ser. No. 63/139,447, filed on Jan. 20, 2021, the contents of which is incorporated by reference herein in its entirety and is to be considered a part of this application.

**REFERENCE REGARDING FEDERALLY
SPONSORED RESEARCH OR DEVELOPMENT**

Not applicable

SEQUENCE LISTING

Not applicable

BACKGROUND**1. Field of the Invention**

The present disclosure relates generally to an article of footwear including a sole plate.

2. Description of the Background

Many conventional shoes or other articles of footwear generally comprise an upper and a sole attached to a lower end of the upper. Conventional shoes further include an internal space, i.e., a void or cavity, which is created by interior surfaces of the upper and sole, that receives a foot of a user before securing the shoe to the foot. The sole is attached to a lower surface or boundary of the upper and is positioned between the upper and the ground. As a result, the sole typically provides stability and cushioning to the user when the shoe is being worn. In some instances, the sole may include multiple components, such as an outsole, a midsole, and a top portion. The outsole may provide traction to a bottom surface of the sole, and the midsole may be attached to an inner surface of the outsole, and may provide cushioning or added stability to the sole. For example, a sole may include a particular foam material that may increase stability at one or more desired locations along the sole, or a foam material that may reduce stress or impact energy on the foot or leg when a user is running, walking, or engaged in another activity. The sole may also include additional components, such as plates, embedded with the sole to increase the overall stiffness of the sole and reduce energy loss during use.

The upper generally extends upward from the sole and defines an interior cavity that completely or partially encases a foot. In most cases, the upper extends over the instep and toe regions of the foot, and across medial and lateral sides thereof. Many articles of footwear may also include a tongue that extends across the instep region to bridge a gap between edges of medial and lateral sides of the upper, which define an opening into the cavity. The tongue may also be disposed below a lacing system and between medial and lateral sides of the upper, to allow for adjustment of shoe tightness. The tongue may further be manipulatable by a user to permit

2

entry or exit of a foot from the internal space or cavity. In addition, the lacing system may allow a user to adjust certain dimensions of the upper or the sole, thereby allowing the upper to accommodate a wide variety of foot types having varying sizes and shapes.

The upper of many shoes may comprise a wide variety of materials, which may be utilized to form the upper and chosen for use based on one or more intended uses of the shoe. The upper may also include portions comprising varying materials specific to a particular area of the upper. For example, added stability may be desirable at a front of the upper or adjacent a heel region so as to provide a higher degree of resistance or rigidity. In contrast, other portions of a shoe may include a soft woven textile to provide an area with stretch-resistance, flexibility, air-permeability, or moisture-wicking properties.

However, in many cases, articles of footwear having uppers with an increased comfort and better fit are desired, along with soles having improved cushioning systems or structural characteristics such as a sole plate to add rigidity or spring-like properties.

SUMMARY

An article of footwear, as described herein, may have various configurations. The article of footwear may have an upper and a sole structure connected to the upper.

According to one aspect of the disclosure, an article of footwear can include an upper and a sole structure coupled to the upper. The sole structure can define a ground engaging surface, and can include a cushioning member coupled to the upper and an outsole coupled to the cushioning member. The outsole can include a central portion and a plurality of lobes extending outward from a periphery of the central portion. Each of the plurality of lobes can be independently movable relative to one another.

In some embodiments, the outsole can include a plurality of ground engaging elements. The plurality of ground engaging elements can include a plurality of removable spikes and a plurality of barbs that can be integrally formed with the outsole. Each of the plurality of removable spikes include a conical tip and each of the plurality of barbs has a triangular pyramidal shape. In some cases, each of the plurality of lobes can include a single removable spike of the plurality of removable spikes and at least one barb of the plurality of barbs.

In some embodiments, the plurality of lobes can include a first plurality of lobes arranged along a medial side of the sole structure and a second plurality of lobes arranged along a lateral side of the sole structure. Each of the first plurality of lobes and the second plurality of lobes can include three lobes. A first lobe of the first plurality of lobes can be positioned directly across the central portion from a second lobe of the second plurality of lobes. The first lobe and the second lobe can extend in opposite directions from one another at their respective connections with the central portion. In some cases, the plurality of lobes can be positioned in a forefoot region of the sole structure. The outsole can define an open area between the first plurality of lobes and the second plurality of lobes. The cushioning member can extend through the open area to define a portion of the ground engaging surface.

In some embodiments, the outsole can be configured as a rigid plate that can include a first portion in a forefoot region of the sole structure, a second portion in a midfoot region of the sole structure, and a third portion in a heel region of the sole structure. The first portion can extend across the fore-

US 11,974,630 B2

3

foot region from a lateral side of the sole structure to a medial side of the sole structure. The second portion can extend partially across the sole structure from the lateral side to the medial side. The third portion can extend partially across the sole structure from the lateral side to the medial side. In some cases, the second portion of the outsole can include a rib protruding from a bottom surface of the outsole. The rib can extend in a direction between the first portion and the second portion of the outsole.

In some embodiments, the cushioning member can be a supercritical foam having pockets of gas therein. In some cases, the gas can be nitrogen.

According to another aspect of the disclosure, an article of footwear can include an upper and a sole structure coupled to the upper. The sole structure can define a ground engaging surface, and can include a cushioning member coupled to the upper and an outsole coupled to the cushioning member. The outsole can include a front outsole segment positioned in a forefoot region and a rear outsole segment positioned in a heel region. The rear segment can be discontinuous with the front outsole segment along the ground engaging surface. The front outsole segment can include a medial segment with a first plurality of lobes arranged along a medial side of the sole structure and a lateral segment with a second plurality of lobes arranged along a lateral side of the sole structure.

In some embodiments, each lobe of the first plurality of lobes and the second plurality of lobes can be independently moveable relative to one another to displace a force to the cushioning member. In some cases, the front outsole segment can be discontinuous along the ground engaging surface between the lateral side and the medial side such that the front outsole segment can define an open area between the lateral segment and the medial segment. The cushioning member can extend across the open area.

In some embodiments, the front outsole segment can include a plurality of first ground engaging elements and a plurality of second ground engaging elements. The plurality of second ground engaging elements can be shaped differently from the first ground engaging elements. Each of the first plurality of lobes and the second plurality of lobes can include a first ground engaging element of the plurality of first ground engaging elements. In some cases, the rear outsole segment can include a plurality of third ground engaging elements.

In some embodiments, the outsole can include a first portion in a forefoot region of the sole structure and a second portion in a midfoot region of the sole structure. The first portion can extend across the forefoot region from a lateral side of the sole structure to a medial side of the sole structure. The second portion can extend partially across the sole structure from the lateral side to the medial side. In some cases, the outsole can include a plurality of ribs extending in a direction between a heel region and the forefoot region.

According to yet another aspect of the disclosure, a sole structure can be provided for an article of footwear having an upper. The sole structure can include cushioning member extending through each of a forefoot region, a midfoot region, and a heel region. A plate can be coupled to the cushioning member. The plate can include a front portion disposed in the forefoot region and a rear portion disposed in the heel region. The front portion can include a first segment and a second segment extending outward from a periphery of the front portion. The second segment can be formed as a plurality of lobes.

4

In some embodiments, the plate can extend continuously through each of the forefoot region, the midfoot region, and the heel region. The second segment can be disposed within the forefoot region. Each of the plurality of lobes of the second segment can be provided with one of a plurality of first ground engaging members. The first segment may not include the plurality of first ground engaging members.

In some embodiments, the second segment can be disposed in the forefoot region and can include a medial segment forming a plurality of medial lobes extending outwardly from the first segment toward a medial side of the sole structure, and a lateral segment forming a plurality of lateral lobes extending outwardly from the first segment toward a lateral side of the sole structure. The plate can define an open area between the medial segment and the lateral segment. The cushioning member can extend through the open area. In some cases, a first lobe of the plurality of medial lobes and a second lobe of the plurality of lateral lobes can be arranged in an opposed configuration about the open area.

According to still another aspect of the disclosure, an article of footwear can include an upper and a sole structure coupled to the upper. The sole structure can define a ground engaging surface, and can include a cushioning member and an outsole. The cushioning member can be coupled to the upper and can extend through each of a forefoot region, a midfoot region, and a heel region. The outsole can include a front portion that can be disposed in the forefoot region and a rear portion that can be disposed in the heel region. The front portion can be discontinuous with the front portion along the ground engaging surface. The front portion is configured as a rigid plate and can include a central segment, a medial segment, and a lateral segment. The medial segment can include a first plurality of lobes extending from a medial periphery of the central segment toward a medial side of the sole structure. Each of the first plurality of lobes can include a medial ground engaging member. The lateral segment can include a second plurality of lobes extending from a lateral periphery of the central segment toward a lateral side of the sole structure. Each of the second plurality of lobes can include a lateral ground engaging member. An open area can be defined between the lateral segment and the medial segment. At least one of the first plurality of lobes can be arranged in an opposed configuration with a corresponding one of the second of plurality lobes about the open area. The cushioning member can extend through the open area to define a portion of the ground engaging surface.

Other aspects of the article of footwear, including features and advantages thereof, will become apparent to one of ordinary skill in the art upon examination of the figures and detailed description herein. Therefore, all such aspects of the article of footwear are intended to be included in the detailed description and this summary.

BRIEF DESCRIPTION OF THE DRAWINGS

FIG. 1 is a lateral side view of an article of footwear configured as a left shoe that includes an upper and a sole structure, according to an embodiment of the disclosure;

FIG. 2 is a bottom view of the article of footwear of FIG. 1;

FIG. 3 is a rear view of the article of footwear of FIG. 1;

FIG. 4 is a lateral side view of an article of footwear configured as a left shoe that includes an upper and a sole structure, according to another embodiment of the disclosure;

US 11,974,630 B2

7

FIG. 62 is a lateral side view of the sole structure of FIG. 60 on an article of footwear;

FIG. 63 is a medial side view of a sole structure for an article of footwear configured as a left shoe, according to another embodiment of the disclosure;

FIG. 64 is a bottom view of the sole structure of FIG. 63;

FIG. 65 is a lateral side view of the sole structure of FIG. 63;

FIG. 66 is a cross-sectional view of the sole structure of FIG. 63 on an article of footwear taken along line 66-66 of FIG. 64; and

FIG. 67 is an isometric view of an outsole of the sole structure of FIG. 63 of an article of footwear.

DETAILED DESCRIPTION OF THE DRAWINGS

The following discussion and accompanying figures disclose various embodiments or configurations of a shoe and a sole structure. Although embodiments of a shoe or sole structure are disclosed with reference to a sports shoe, such as a running shoe, tennis shoe, basketball shoe, etc., concepts associated with embodiments of the shoe or the sole structure may be applied to a wide range of footwear and footwear styles, including cross-training shoes, football shoes, golf shoes, hiking shoes, hiking boots, ski and snowboard boots, soccer shoes and cleats, walking shoes, and track cleats, for example. Concepts of the shoe or the sole structure may also be applied to articles of footwear that are considered non-athletic, including dress shoes, sandals, loafers, slippers, and heels. In addition to footwear, particular concepts described herein may also be applied and incorporated in other types of apparel or other athletic equipment, including helmets, padding or protective pads, shin guards, and gloves. Even further, particular concepts described herein may be incorporated in cushions, backpack straps, golf clubs, or other consumer or industrial products. Accordingly, concepts described herein may be utilized in a variety of products.

The term “about,” as used herein, refers to variation in the numerical quantity that may occur, for example, through typical measuring and manufacturing procedures used for articles of footwear or other articles of manufacture that may include embodiments of the disclosure herein; through inadvertent error in these procedures; through differences in the manufacture, source, or purity of the ingredients used to make the compositions or mixtures or carry out the methods; and the like. Throughout the disclosure, the terms “about” and “approximately” refer to a range of values $\pm 5\%$ of the numeric value that the term precedes.

The terms “weight percent,” “wt-%,” “percent by weight,” “% by weight,” and variations thereof, as used herein, refer to the concentration of a substance or component as the weight of that substance or component divided by the total weight, for example, of the composition or of a particular component of the composition, and multiplied by 100. It is understood that, as used herein, “percent,” “%,” and the like may be synonymous with “weight percent” and “wt-%.”

As used herein in the context of geometric descriptions, unless otherwise limited or defined, “substantially” indicates correspondence to a particular shape or dimension within conventional manufacturing tolerances for components of a similar type or that are formed using similar processes. In this regard, for example, “substantially round” can indicate a profile that deviates from a circle to within acceptable manufacturing tolerances.

8

Further, as used herein, unless otherwise defined or limited, directional terms are used for convenience of reference for discussion of particular figures or examples. For example, references to “downward,” or other directions, or “lower” or other positions, may be used to discuss aspects of a particular example or figure, but do not necessarily require similar orientation or geometry in all installations or configurations.

The present disclosure is directed to an article of footwear and/or specific components of the article of footwear, such as an upper and/or a sole or sole structure. The upper may comprise a knitted component, a woven textile, and/or a non-woven textile. The knitted component may be made by knitting of yarn, the woven textile by weaving of yarn, and the non-woven textile by manufacture of a unitary non-woven web. Knitted textiles include textiles formed by way of warp knitting, weft knitting, flat knitting, circular knitting, and/or other suitable knitting operations. The knit textile may have a plain knit structure, a mesh knit structure, and/or a rib knit structure, for example. Woven textiles include, but are not limited to, textiles formed by way of any of the numerous weave forms, such as plain weave, twill weave, satin weave, dobbin weave, jacquard weave, double weaves, and/or double cloth weaves, for example. Non-woven textiles include textiles made by air-laid and/or spun-laid methods, for example. The upper may comprise a variety of materials, such as a first yarn, a second yarn, and/or a third yarn, which may have varying properties or varying visual characteristics.

FIGS. 1-3 depict an embodiment of an article of footwear 100 including an upper 102 a top portion 120, and a sole structure 104. The upper 102 is attached to the top portion 120 and together define an interior cavity into which a foot may be inserted. For reference, the article of footwear 100 defines a forefoot region 108, a midfoot region 110, and a heel region 112. The forefoot region 108 generally corresponds with portions of the article of footwear 100 that encase portions of the foot that includes the toes, the ball of the foot, and joints connecting the metatarsals with the toes or phalanges. The midfoot region 110 is proximate and adjoining the forefoot region 108, and generally corresponds with portions of the article of footwear 100 that encase the arch of the foot, along with the bridge of the foot. The heel region 112 is proximate and adjoining the midfoot region 110 and generally corresponds with portions of the article of footwear 100 that encase rear portions of the foot, including the heel or calcaneus bone, the ankle, and/or the Achilles tendon.

Many conventional footwear uppers are formed from multiple elements (e.g., textiles, polymer foam, polymer sheets, leather, and synthetic leather) that are joined through bonding or stitching at a seam. In some embodiments, the upper 102 of the article of footwear 100 is formed from a knitted structure or knitted components. In various embodiments, a knitted component may incorporate various types of yarn that may provide different properties to an upper. For example, one area of the upper 102 may be formed from a first type of yarn that imparts a first set of properties, and another area of the upper 102 may be formed from a second type of yarn that imparts a second set of properties. Using this configuration, properties of the upper 102 may vary throughout the upper 102 by selecting specific yarns for different areas of the upper 102.

The article of footwear 100 also includes a medial side 116 (e.g., see FIG. 2) and a lateral side 118 (e.g., see FIG. 2). In particular, the lateral side 118 corresponds to an outside portion of the article of footwear 100 and the medial

US 11,974,630 B2

9

side 116 corresponds to an inside portion of the article of footwear 100. As such, left and right articles of footwear have opposing lateral and medial sides, such that the medial sides 116 are closest to one another when a user is wearing the articles of footwear 100, while the lateral sides 118 are defined as the sides that are farthest from one another while being worn. The medial side 116 and the lateral side 118 adjoin one another at opposing, distal ends of the article of footwear 100.

Unless otherwise specified, the forefoot region 108, the midfoot region 110, the heel region 112, the medial side 116, and the lateral side 118 are intended to define boundaries or areas of the article of footwear 100. To that end, the forefoot region 108, the midfoot region 110, the heel region 112, the medial side 116, and the lateral side 118 generally characterize sections of the article of footwear 100. Further, the upper 102, the top portion 120, and the sole structure 104 may be characterized as having portions within the forefoot region 108, the midfoot region 110, the heel region 112, and on the medial side 116 and the lateral side 118. Therefore, the upper 102, the top portion 120, and the sole structure 104, and/or individual portions of the upper 102, the top portion 120, and the sole structure 104, may include portions thereof that are disposed within the forefoot region 108, the midfoot region 110, the heel region 112, and on the medial side 116 and the lateral side 118.

The top portion 120 is connected to the upper 102 and, as stated above, can provide support for an arch of a user. The top portion 120 can be a strobrel board, a forefoot board, a lasting board, etc., or a combination thereof and may include an insole. In some embodiments, the top portion 120 can provide support for an arch of a user.

The sole structure 104 is connected or secured to the top portion 120 and extends between a foot of a user and the ground when the article of footwear 100 is worn by the user. The sole structure 104 may include one or more components, which may include an outsole, a midsole, and/or a heel. For example, in some embodiments, a sole structure may include an outsole that provides structural integrity to the sole structure, along with providing traction for a user, and a midsole that provides a cushioning system. As will be further discussed herein, the sole structure 104 of the present embodiment of the invention includes one or more components that provide the sole structure 104 with preferable spring and damping properties.

The sole structure 104 includes an outsole 130. The outsole 130 may be a rigid plate formed from one or more materials to impart durability, wear-resistance, abrasion resistance, or traction to the sole structure 104. In some embodiments, the outsole 130 may comprise a polyurethane (PU) plastic, such as a thermoplastic polyurethane (TPU) material, for example. Other thermoplastic elastomers consisting of block copolymers are also possible. In other embodiments, the outsole 130 can include carbon fiber or high-density wood, for example. In some embodiments, the outsole 130 has a uniform thickness.

As shown in FIGS. 1 and 2, the outsole 130 has a front portion 132, a middle portion 134, and a rear portion 136. The outsole 130 extends front to rear through the forefoot region 108 and the midfoot region 110 and at least partially through the heel region 112. Further, the outsole 130 can extend across the entire forefoot region 108 from the medial side 116 to the lateral side 118 and only partially across the midfoot and heel regions 110, 112. The front portion 132 of the outsole 130 is coupled to the upper 102 and the top portion 120 at the forefoot region 108 at a forefoot coupling point 176 and the middle portion 134 is coupled to the top

10

portion 120 at the midfoot region 110 at a midfoot coupling point 178. The outsole 130 is spaced from the top portion 120 between the forefoot coupling point 176 and the midfoot coupling point 178, and defines a front spacing 140 at the forefoot region 108.

The article of footwear 100 is shown in a rested, or unloaded state (i.e., no downward force is being exerted on the article of footwear 100 other than the nominal force of gravity). When viewed from the side and from beneath, the front spacing 140 has a first longitudinal length 122 defined as a straight line distance between the forefoot coupling point 176 and the midfoot coupling point 178. In the embodiment shown, the front spacing 140 has a crescent profile with a curved length 124 defined as a curved line following the midpoint between the top portion 120 and the outsole 130 along the first longitudinal length 122 and between the forefoot coupling point 176 and the midfoot coupling point 178. The front spacing 140 also has a first gap height 126 defined by the distance between the top portion 120 and the outsole 130. The first gap height 126 changes along the curved length 124, increasing and then decreasing from the forefoot region 108 to the midfoot region 110, with the first gap height 126 being largest beneath where the ball of a user's foot would be received within the upper 102 and being defined as the maximum first gap height 126A. The front spacing 140 also has a front spacing volume 128 as defined by the top portion 120, the outsole 130, and an unseen boundary extending from and between the periphery of the top portion 120 and the outsole 130.

As further illustrated in FIGS. 1 and 3, the middle portion 134 of the outsole 130 extends away from the midfoot coupling point 178, spacing the rear portion 136 of the outsole 130 at the heel region 112 from the top portion 120 and defining a rear spacing 142 between the rear portion 136 and the top portion 120. When viewed from the side, the rear spacing 142 has a wedge profile. As shown, the rear spacing 142 has a second longitudinal length 170 defined as a straight line distance between the midfoot coupling point 178 and a terminal end 160 of the rear portion 136 of the outsole 130. The rear spacing 142 also has a second gap height 172 defined by the distance between the top portion 120 and the outsole 130 along the second longitudinal length 170. The second gap height 172 increases from the midfoot region 110 toward the heel region 112 and is substantially constant along the heel region 112 beneath where the heel of a user's foot would be received within the upper 102. The greatest height of the second gap height 172 defining a maximum second gap height 172A. The rear spacing 142 also has a rear spacing volume 174 as defined by the top portion 120, the outsole 130, and an unseen boundary extending from and between the periphery of the top portion 120 and the outsole 130 in the heel region 112.

In the rested state, the first longitudinal length 122 of the article of footwear 100 is greater than the second longitudinal length 170 and the maximum first gap height 126A is smaller than the maximum second gap height 172A. In some embodiments, the first longitudinal length 122 can be in a range from about 1.5 times to about 2.0 times the second longitudinal length 170. In some embodiments, the maximum second gap height 172A can be in a range from about 1.1 times to about 1.5 times the maximum first gap height 126A. In some embodiments, the front spacing volume is approximately the same as the rear spacing volume.

In a neutral state (not shown), when a user's foot is received within the upper 102 and the user is standing (i.e., no downward force is being applied to the article of footwear 100 other than the weight of the user), the first gap height

US 11,974,630 B2

11

126 is decreased due to the top portion 120 being urged toward the outsole 130 under the force of the weight of the user. In some embodiments, for example, the percentage decrease in the front spacing volume 128 from the rested state to the neutral state can be in a range of about 1 percent to about 20 percent, more preferably the percentage decrease in the front spacing volume 128 can be in a range of about 5 percent to about 10 percent. Additionally, the rear spacing volume 174 will be decreased in the neutral state. In some embodiments, for example, the percentage decrease of the rear spacing volume 174 from the rested state to the neutral state can be in a range of about 1 percent to about 50 percent, more preferably the percentage decrease in the rear spacing volume 174 can be in a range of about 10 percent to about 30 percent. Further, the middle portion 134 of the outsole 130 contacts the top portion 120 in the midfoot region 110 and provides additional support of the arch of the user when in the neutral state.

During use, in an active state (not shown), when the outsole 130 is in contact with the ground and a user exerts a downward force in the forefoot region 108, the downward force will urge the top portion 120 toward the outsole 130 and further decrease the front spacing volume 128 while lengthening the first longitudinal length 122. In some embodiments, for example, the percentage decrease in the first spacing volume 128 from the rested state to the active state can be a range of about 10 percent to about 100 percent, more preferably, the percentage decrease in the front spacing volume 128 can be in a range of about 50 percent to about 90 percent. Additionally, in the active state, if a user applies a force to the heel portion 112, the rear spacing volume 174 can experience a percentage decrease in volume. In some embodiments, for example, the decrease in volume from the rested state to the active state can be in a range of about 90 percent to about 100 percent. Further, the middle portion 134 of the outsole 130 can act as a fulcrum when in the active state. For example, a user can strike the heel portion 112 on the ground while walking or running and rotate the foot forward about the middle portion 134 in the midfoot region 110, and continue rotating the foot forward, striking the forefoot region 108 on the ground.

The outsole 130 along with the front spacing 140 and the rear spacing 142 can therefore provide force absorption as a user exerts downward force onto the forefoot region 108 and the heel region 112, respectively, of the article of footwear 100 and can also provide a spring effect as the downward force from the user is relieved. This can reduce the severity of the impact to a user's foot and leg joints during use.

The outsole 130 may define a bottom end or bottom surface 138 of the sole structure 104 across the forefoot region 108, the midfoot region 110, and the heel region 112. Further, the outsole 130 may be a ground-engaging portion or include a ground-engaging surface of the sole structure 104 and may be opposite of the upper 102. For example, the outsole 130 can include any combination of ground engaging members (e.g., spikes 144, teeth 146, and barbs 148) that extend from the bottom surface 138 of the outsole 130 and which can be positioned throughout the front portion 132 and the rear portion 136.

As shown, the article of footwear 100 includes spikes 144 and teeth 146 in the front portion 132 and barbs 148 in the front and rear portions 132, 136. The number and placement of spikes can affect traction with respect to linear movement. In some embodiments, the spikes 144 can vary in shape and size depending on user preference and environmental considerations such as the type of ground surface covering and weather conditions. For example, see the small spikes 1794

12

in FIGS. 49-53 and as discussed with respect to another embodiment or an article of footwear 1700 below. It is contemplated that at least one of the spikes 144 can be removable.

The teeth 146 can extend from and can be spaced around the periphery of the outsole 130 in the front portion 132. As shown, the teeth 146 can be blade-like and can have a rectangular profile. The number and placement of teeth 146 can affect traction with respect to lateral and medial (i.e., side-to-side) movement. In some embodiments, the teeth 146 can be formed as part of the outsole 130 during the production of the outsole 130 (e.g., the teeth 146 can be formed as continuous extensions of the outsole 130). Further, the teeth 146 can be provided in groups, for example in groups of two or three as shown. Teeth 146 can also be provided in front of a user's toe to support "toe off."

The barbs 148 can extend from the outsole 130 at multiple locations and can be angled toward the rear of the article of footwear 100. In some embodiments, the barbs 148 can be formed as part of the outsole 130 (e.g., the barbs 148 can be formed as continuous extensions of the outsole 130).

FIGS. 4-6 show another embodiment of an article of footwear 200. In many aspects, the article of footwear 200 is similar to the article of footwear 100 described above and similar numbering in the 200 series is used for the article of footwear 200. For example, the article of footwear 200 includes an upper 202, a top portion 220, and a sole structure 204 with an outsole 230. The upper 202 defines a forefoot region 208, a midfoot region 210, and a heel region 212. Further, the article of footwear 200 also includes a medial side 216 corresponding to an inside portion of the article of footwear 200 and a lateral side 218 corresponding to an outside portion of the article of footwear 200.

Additionally, the outsole 230 may be a rigid plate formed from one or more materials to impart durability, wear-resistance, abrasion resistance, or traction to the sole structure 204. The outsole 230 has a front portion 232, a middle portion 234, and a rear portion 236 with a terminal end 260. The outsole 230 extends front to rear through the forefoot region 208 and the midfoot region 210 and at least partially through the heel region 212. Further, the outsole 230 can extend across the entire forefoot region 208 from the medial side 216 to the lateral side 218 and only partially across the midfoot and heel regions 210, 212. The front portion 232 of the outsole 230 is coupled to the top portion 220 at the forefoot region 208 at a forefoot coupling point 276 and the middle portion 234 is coupled to the top portion 220 at the midfoot region 210 at a midfoot coupling point 278. The outsole 230 is spaced from the top portion 220 between the forefoot coupling point 276 and the midfoot coupling point 278, and defines a front spacing 240, a first longitudinal length 222, a curved length 224, a first gap height 226 with a maximum first gap height 226A, and a front spacing volume 228. As further illustrated in FIGS. 4 and 6, the middle portion 234 of the outsole 230 extends away from the midfoot coupling point 278, spacing the rear portion 236 of the outsole 230 from the top portion 220 and defining a rear spacing 242, a second longitudinal length 270, a second gap height 272 with a maximum second gap height 272A, and a rear spacing volume 274. The outsole 230 also has at least one ground engaging member (e.g., a spike 244, a tooth 246, or a barb 248) extending from a bottom surface 238 thereof.

In some aspects, however, the articles of footwear 100, 200 differ from each other. For example, the sole structure 204 includes a front cushioning member 250. The front cushioning member 250 may be positioned within the front spacing 240 between the outsole 230 and the upper 202 and

US 11,974,630 B2

13

can extend across the front portion **232** from the medial side **216** to the lateral side **218**. In some embodiments, for example, the volume of the front cushioning member **250** can be in a range of about 85 percent to about 95 percent of the front spacing volume **228**.

The front cushioning member **250** can be individually constructed from a thermoplastic material, such as PU, for example, and/or an ethylene-vinyl acetate (EVA), copolymers thereof, or a similar type of material. In other embodiments, the front cushioning member **250** may be an EVA-Solid-Sponge (“ESS”) material, an EVA foam (e.g., PUMA® ProFoam Lite™, IGNITE Foam), polyurethane, polyether, an olefin block copolymer, a thermoplastic material (e.g., a thermoplastic polyurethane, a thermoplastic elastomer, a thermoplastic polyolefin, etc.), or a supercritical foam. The front cushioning member **250** may be a single polymeric material or may be a blend of materials, such as an EVA copolymer, a thermoplastic polyurethane, a polyether block amide (PEBA) copolymer, and/or an olefin block copolymer. One example of a PEBA material is PEBAX®.

In embodiments where the front cushioning member **250** is formed from a supercritical foaming process, the supercritical foam may comprise micropore foams or particle foams, such as a TPU, EVA, PEBAX®, or mixtures thereof, manufactured using a process that is performed within an autoclave, an injection molding apparatus, or any sufficiently heated/pressurized container that can process the mixing of a supercritical fluid (e.g., CO₂, N₂, or mixtures thereof) with a material (e.g., TPU, EVA, polyolefin elastomer, or mixtures thereof) that is preferably molten. In one example process, a solution of supercritical fluid and molten material can be pumped into a pressurized container, after which the pressure within the container is released, such that the molecules of the supercritical fluid rapidly convert to gas to form small pockets within the material and cause the material to expand into a foam, which may be used as the front cushioning member **250**. In further embodiments, the front cushioning member **250** may be formed using alternative methods known in the art, including the use of an expansion press, an injection machine, a pellet expansion process, a cold foaming process, a compression molding technique, die cutting, or any combination thereof. For example, the front cushioning member **250** may be formed using a process that involves an initial foaming step in which supercritical gas is used to foam a material and then compression molded or die cut to a particular shape. Additionally, or alternatively, an air-bladder/bag made out of blown polymer (e.g., TPU) and pressurized with air can be used as a front cushioning member.

The sole structure **204** as described with the front cushioning member **250** provided within the front spacing **240** of the outsole **230** can provide spring and dampening properties. This can reduce the severity of the impact to a user’s foot and leg joints during use.

FIGS. 7-9 show another embodiment of an article of footwear **300**. In many aspects, the article of footwear **300** is similar to the article of footwear **200** described above and similar numbering in the **300** series is used for the article of footwear **300**. For example, the article of footwear **300** includes an upper **302**, a top portion **320**, and a sole structure **304** with an outsole **330**. The upper **302** defines a forefoot region **308**, a midfoot region **310**, and a heel region **312**. Further, the article of footwear **300** also includes a medial side **316** corresponding to an inside portion of the article of footwear **300** and a lateral side **318** corresponding to an outside portion of the article of footwear **300**.

14

Additionally, the outsole **330** may be a rigid plate formed from one or more materials to impart durability, wear-resistance, abrasion resistance, or traction to the sole structure **304**. The outsole **330** has a front portion **332**, a middle portion **334**, and a rear portion **336** with a terminal end **360**. The outsole **330** extends front to rear through the forefoot region **308** and the midfoot region **310** and at least partially through the heel region **312**. Further, the outsole **330** can extend across the entire forefoot region **308** from the medial side **316** to the lateral side **318** and only partially across the midfoot and heel regions **310**, **312**. The front portion **332** of the outsole **330** is coupled to the top portion **320** at the forefoot region **308** at a forefoot coupling point **376** and the middle portion **334** is coupled to the top portion **320** at the midfoot region **310** at a midfoot coupling point **378**. The outsole **330** is spaced from the top portion **320** between the forefoot coupling point **376** and the midfoot coupling point **378**, defining a front spacing **340** at the forefoot region **308**, a first longitudinal length **322**, a curved length **324**, a first gap height **326** with a maximum first gap height **326A**, and a front spacing volume **328**. As further illustrated in FIGS. 7 and 9, the middle portion **334** of the outsole **330** extends away from the midfoot coupling point **378**, spacing the rear portion **336** of the outsole **330** from the top portion **320** and defining a rear spacing **342**, a second longitudinal length **370**, a second gap height **372** with a maximum second gap height **372A**, and a rear spacing volume **374**. The outsole **330** also has at least one ground engaging member (e.g., a spike **344**, a tooth **346**, or a barb **348**) extending from a bottom surface **338** thereof.

Further, the sole structure **304** includes a front cushioning member **350**. The front cushioning member **350** is positioned within the front spacing **340** between the outsole **330** and the upper **302** and extends across the forefoot region **308** from the medial side **316** to the lateral side **318** similar to that of the front cushioning member **250** in the article of footwear **200**. The front cushioning member **350** can be formed from any of the materials and processes described above with respect to the front cushioning member **250** of the article of footwear **200**.

In some aspects, however, the articles of footwear **200**, **300** differ from each other. For example, the sole structure **304** also includes a rear cushioning member **352**. The rear cushioning member **352** may be positioned within the rear spacing **342** between the outsole **330** and the upper **302**. The rear cushioning member **352** extends across a portion of the rear portion **336** of the outsole **330**. In some embodiments, for example, the volume of the rear cushioning member **352** can be in a range of about 35 percent to about 50 percent of the rear spacing volume **374**. In some embodiments, the rear cushioning member **352** can define a rear spacing pocket **354** adjacent the front side of the rear cushioning member **352**. The rear spacing pocket **354** extends longitudinally between the midfoot coupling point **378** and the rear cushioning member **352**, latitudinally between the medial side **316** and the lateral side **318**, and vertically between the top portion **320** and the outsole **330**. As shown in FIGS. 7 and 9, the rear cushioning member **352** is positioned directly beneath where the heel of a user’s foot would be received within the upper **302**. For example, the rear cushioning member **352** is positioned within the rear spacing pocket **354** at the location of and adjacent the maximum second gap height **372A**. The rear cushioning member **352** can be formed from any of the materials and processes described above with respect to the front cushioning member **250** of the article of footwear **200**.

The sole structure **304** as described with the front cushioning member **350** provided within the front spacing **340** of the outsole **330** and the rear cushioning member **352** provided within the rear spacing **342** of the outsole **330** can provide spring and dampening properties, which can reduce the severity of the impact to a user's foot and leg joints during use.

FIGS. 10-24 show other embodiments of an article of footwear **400**, **500**, **600**, **700**, **800**. In many aspects, the articles of footwear **400**, **500**, **600**, **700**, **800** are similar to the articles of footwear **100**, **200**, **300** described above and similar numbering in the **400**, **500**, **600**, **700**, **800** series is used for the articles of footwear **400**, **500**, **600**, **700**, **800**. For example, each of the articles of footwear **400**, **500**, **600**, **700**, **800** include an upper **402**, **502**, **602**, **702**, **802**; a top portion **420**, **520**, **620**, **720**, **820**; and a sole structure **404**, **504**, **604**, **704**, **804** with an outsole **430**, **530**, **630**, **730**, **830**. Each outsole **430**, **530**, **630**, **730**, **830** may be a rigid plate and has a front portion **432**, **532**, **632**, **732**, **832**; a middle portion **434**, **534**, **634**, **734**, **834**; and a rear portion **436**, **536**, **636**, **736**, **836** with a terminal end **460**, **560**, **660**, **760**, **860**. Additionally, each article of footwear **400**, **500**, **600**, **700**, **800** defines a forefoot region **408**, **508**, **608**, **708**, **808**; a midfoot region **410**, **510**, **610**, **710**, **810**; and a heel region **412**, **512**, **612**, **712**, **812** and has a medial side **416**, **516**, **616**, **716**, **816** and a lateral side **418**, **518**, **618**, **718**, **818**. The outsole **430**, **530**, **630**, **730**, **830** can also be coupled to the top portion **420**, **520**, **620**, **720**, **820** at a forefoot coupling point **476**, **576**, **676**, **767**, **876** and at a midfoot coupling point **478**, **578**, **678**, **778**, **878**.

Further, each article of footwear **400**, **500**, **600**, **700**, **800** defines a front spacing **440**, **540**, **640**, **740**, **840** with a first longitudinal length **422**, **522**, **622**, **722**, **822**; a curved length **424**, **524**, **624**, **724**, **824**; a first gap height **426**, **526**, **626**, **726**, **826** with a maximum first gap height **426A**, **526A**, **626A**, **726A**, **826A**; and a front spacing volume **428**, **528**, **628**, **728**, **828** and a rear spacing **442**, **542**, **642**, **742**, **842** with a second longitudinal length **470**, **570**, **670**, **770**, **870**; a second gap height **472**, **572**, **672**, **772**, **872** with a maximum second gap height **472A**, **572A**, **672A**, **772A**, **872A**; and a rear spacing volume **474**, **574**, **674**, **774**, **874** and has at least one ground engaging member (e.g., a spike **444**, **544**, **644**, **744**, **844**; a tooth **446**, **546**, **646**, **746**, **846**; or a barb **448**, **548**, **648**, **748**, **848**) extending from a bottom surface **438**, **538**, **638**, **738**, **838** of the outsole **430**, **530**, **630**, **730**, **830**. However, each embodiment differs regarding the inclusion and arrangement of the front and rear cushioning members. When included, however, the materials comprising and processes for making the front and rear cushioning members are as described above.

FIGS. 10-12 illustrate the article of footwear **400** in which both a front cushioning member **450** and a rear cushioning member **452** are provided (hidden in FIG. 11). The front cushioning member **450** is positioned within the front spacing **440** between the outsole **430** and the upper **402** and extends across the front portion **432** of the outsole **430** from the medial side **416** to the lateral side **418**. In some embodiments, for example, the volume of the front cushioning member **450** can be in a range of about 85 percent to about 95 percent of the front spacing volume **428**. Further, the rear cushioning member **452** is positioned within the rear spacing **442** between the outsole **430** and the upper **402** and extends across the rear portion **436** of the outsole **430** from the medial side **416** to the lateral side **418**. In some embodiments, for example, the volume of the rear cushioning member **452** can be in a range of about 70 percent to about 95 percent of the rear spacing volume **474**.

In FIGS. 13-15, the article of footwear **500** is shown with both a front cushioning member **550** and a rear cushioning member **552** (hidden in FIG. 14). The front cushioning member **550** is positioned within the front spacing **540** between the outsole **530** and the upper **502** and extends across a portion of the front portion **532** of the outsole **530**. In some embodiments, for example, the volume of the front cushioning member **550** can be in a range of about 35 percent to about 50 percent of the front spacing volume **528**. In some embodiments, the front cushioning member **550** defines a first front spacing pocket **556** and a second front spacing pocket **558** adjacent the front and rear sides of the front cushioning member **550**, respectively. The first front spacing pocket **556** extends longitudinally between the forefoot coupling point **576** and the front cushioning member **550**, latitudinally between the medial side **516** and the lateral side **518**, and vertically between the top portion **520** and the outsole **530**. The second front spacing pocket **558** extends longitudinally between the front cushioning member **550** and the midfoot coupling point **578**, latitudinally from the medial side **516** to the lateral side **518**, and vertically between the top portion **520** and the outsole **530**. As shown, the front cushioning member **550** can be positioned directly beneath where the ball of a user's foot would be received within the upper **502**. For example, the front cushioning member **550** is positioned within the front spacing pocket **556** at the location of and adjacent the maximum first gap height **526A**. Further, the rear cushioning member **552** is positioned within the rear spacing **542** between the outsole **530** and the upper **502** and extends across the rear portion **536** of the outsole **530** from the medial side **516** to the lateral side **518**. In some embodiments, for example, the volume of the rear cushioning member **552** can be in a range of about 70 percent to about 95 percent of the rear spacing volume **574**.

FIGS. 16-18 show the article of footwear **600** with both a front cushioning member **650** and a rear cushioning member **652** (hidden in FIG. 17). The front cushioning member **650** is positioned within the front spacing **640** between the outsole **630** and the upper **602** and extends across a portion of the front portion **632** of the outsole **630**. In some embodiments, for example, the volume of the front cushioning member **650** can be in a range of about 35 percent to about 50 percent of the front spacing volume **628**. In some embodiments, the front cushioning member **650** defines a first front spacing pocket **656** and a second front spacing pocket **658** adjacent the front and rear sides of the front cushioning member **650**, respectively. The first front spacing pocket **656** extends longitudinally between the forefoot coupling point **676** and the front cushioning member **650**, latitudinally between the medial side **616** and the lateral side **618**, and vertically between the top portion **620** and the outsole **630**. The second front spacing pocket **658** extends longitudinally between the front cushioning member **650** and the midfoot coupling point **678**, latitudinally between the medial side **616** and the lateral side **618**, and vertically between the top portion **620** and the outsole **630**. As shown, the front cushioning member **650** can be positioned directly beneath where the ball of a user's foot would be received within the upper **602**. For example, the front cushioning member **650** is positioned within the front spacing pocket **656** at the location of and adjacent the maximum first gap height **626A**. The rear cushioning member **652** is positioned within the rear spacing **642** between the outsole **630** and the upper **602**. The rear cushioning member **652** extends across a portion of the rear portion **636** of the outsole **630**. In some embodiments, for example, the volume

of the rear cushioning member **652** can be in a range of about 35 percent to about 50 percent of the rear spacing volume **674**. In some embodiments, the rear cushioning member **652** can define a rear spacing pocket **654** adjacent the front side of the rear cushioning member **652**. The rear spacing pocket **654** extends longitudinally between the midfoot coupling point **678** and the rear cushioning member **652**, latitudinally between the medial side **616** and the lateral side **618**, and vertically between the top portion **620** and the outsole **630**. As shown, the rear cushioning member **652** is positioned directly beneath where the heel of a user's foot would be received within the upper **602**. For example, the rear cushioning member **652** is positioned within the rear spacing pocket **654** at the location of and adjacent the maximum second gap height **672A**.

The article of footwear **700** is shown in FIGS. **19-21**. The article of footwear **700** does not have a front cushioning member within the front spacing **740** but does have a rear cushioning member **752** within the rear spacing **742** (hidden in FIG. **20**). The rear cushioning member **752** is positioned within the rear spacing **742** between the outsole **730** and the upper **702**. The rear cushioning member **752** extends across a portion of the rear portion **736** of the outsole **730**. In some embodiments, for example, the volume of the rear cushioning member **752** can be in a range of about 35 percent to about 50 percent of the rear spacing volume **774**. In some embodiments, the rear cushioning member can define a rear spacing pocket **754** adjacent the front side of the rear cushioning member **752**. The rear spacing pocket **754** extends longitudinally between the midfoot coupling point **778** and the rear cushioning member **752**, latitudinally between the medial side **716** and the lateral side **718**, and vertically between the top portion **720** and the outsole **730**. As shown, the rear cushioning member **752** is positioned directly beneath where the heel of a user's foot would be received within the upper **702**. For example, the rear cushioning member **752** is positioned within the rear spacing pocket **754** at the location of and adjacent the maximum second gap height **772A**.

FIGS. **22-24** illustrate the article of footwear **800**. The article of footwear **800** does not have a front cushioning member within the front spacing **840** but does have a rear cushioning member **852** within the rear spacing **842** (hidden in FIG. **23**). The rear cushioning member **852** is positioned within the rear spacing **842** between the outsole **830** and the upper **802** and extends across the rear portion **836** of the outsole **830** from the medial side **816** to the lateral side **818**. In some embodiments, for example, the volume of the rear cushioning member **852** can be in a range of about 70 percent to about 95 percent of the rear spacing volume **874**.

FIGS. **25-27** show another embodiment of an article of footwear **900**. In many aspects, the article of footwear **900** is similar to the article of footwear **100** described above and similar numbering in the **900** series is used for the article of footwear **900**. For example, the article of footwear **900** includes an upper **902**, a top portion **920**, and a sole structure **904** with an outsole **930**. The upper **902** defines a forefoot region **908**, a midfoot region **910**, and a heel region **912**. Further, the article of footwear **900** also includes a medial side **916** corresponding to an inside portion of the article of footwear **900** and a lateral side **918** corresponding to an outside portion of the article of footwear **900**.

Further, the outsole **930** may be a rigid plate formed from one or more materials to impart durability, wear-resistance, abrasion resistance, or traction to the sole structure **904**. The outsole **930** may comprise a PU plastic, such as a TPU material, for example. Other thermoplastic elastomers con-

sisting of block copolymers are also possible. In other embodiments, the outsole **930** can include carbon fiber or high-density wood, for example. The outsole **930** can also include any combination of ground engaging members (e.g., spikes **944**, teeth **946**, and barbs **948**) extending from the outsole **930** to aid in traction.

In some aspects, however, the articles of footwear **100**, **900** differ from each other. For example, the outsole **930** includes an upper outsole **930A** and a lower outsole **930B**. The upper outsole **930A** extends along the top portion **920** and can be attached thereto. The upper outsole **930A** extends from the forefoot region **908** through the heel region **912** and from the medial side **916** to the lateral side **918**. The upper outsole **930A** has a front portion **932**, a middle portion **934**, and a rear portion **936**. In some embodiments, the upper outsole **930A** can have a uniform thickness.

The lower outsole **930B** extends from and along the upper outsole **930A**. In some embodiments, the outsole **930**, including the upper outsole **930A** and the lower outsole **930B**, can be integrally formed as a continuous and unitary structure. The lower outsole **930B** has a front portion **962**, a middle portion **964**, and a rear portion **966**. In some embodiments, the lower outsole **930B** can have a uniform thickness. In some embodiments, the lower outsole **930B** can have a thickness substantially the same as the thickness of the upper outsole **930A**.

In FIGS. **25** and **27**, the article of footwear **900** is shown in a rested or unloaded state. The lower outsole **930B** has a cross-like shape with a center section **980** and is connected to the upper outsole **932** at locations at the front portion **962** of the article of footwear **900** at a forefoot coupling point **976A** and at the medial and lateral sides **916**, **918** in the forefoot region **908** at a medial coupling point **984** and a lateral coupling point **986**, respectively. However, it is contemplated that the lower outsole **930B** can be attached to the upper outsole **930A** in other locations, including, for example, around the periphery of the front portion **932** of the upper outsole **930A**. The middle portion **964** of the lower outsole **930B** can also be attached to the middle portion **934** of the upper outsole **930A** in the midfoot region **910** of the article of footwear **900** at a midfoot coupling point **978**. The lower outsole **930B** is spaced from the upper outsole **930A** between the forefoot coupling point **976**, the medial coupling point **984**, the lateral coupling point **986**, and the midfoot coupling point **978**, defining a front spacing **940**. The front spacing **940** has a first longitudinal length **922** defined as a straight line distance between the coupling points of the upper outsole **930A** and the lower outsole **930B** at the forefoot region **908** and at the midfoot region **910**. The front spacing **940** also has a latitudinal width **982** defined as a straight line distance between the coupling points of the upper outsole **930A** and the lower outsole **930B** at the medial and lateral sides **916**, **918** (see FIG. **26**). In the embodiment shown, when looking from the side (see FIG. **25**), the front spacing **940** has a crescent profile, which has a curved length **924** defined as a curved line following the midpoint between the upper outsole **930A** and the lower outsole **930B** along the first longitudinal length **922** and between the forefoot coupling point **976** and the midfoot coupling point **978**. The front spacing **940** also has a first gap height **926** defined by the distance between the upper outsole **920A** and the lower outsole **930B**.

The first gap height **926** is largest at the center section **980**, defining a maximum first gap height **980A**, and decreases moving outward from the center section **980** along the first longitudinal length **922** and along the latitudinal width **982**. The front spacing **940** also has a front spacing

volume **928** as defined by the upper outsole **920A**, the lower outsole **930B**, and an unseen boundary extending from and between the periphery of the lower outsole **920B** and the upper outsole **930A**.

As illustrated in FIGS. **25** and **27**, the middle portion **964** of the lower outsole **930B** extends away from the middle portion **934** of the upper outsole **930A** at the connection point in midfoot region **910**. The rear portion **966** of the lower outsole **930B** is spaced from the rear portion **936** of the upper outsole **930A**, defining a rear spacing **942** between the rear portions **936**, **966**. When viewed from the side, the rear spacing **942** has a wedge profile. As shown, the rear spacing **942** has a second longitudinal length **970** defined as a straight line distance between the midfoot coupling point **978** and a terminal end **960** of the rear portion **936** of the lower outsole **930B**. The rear spacing **942** also has a second gap height **972** defined by the distance between the upper outsole **930A** and the lower outsole **930B** along the second longitudinal length **970**. The second gap height **972** increases from the midfoot region **910** toward the heel region **912** along the second longitudinal length **970** and is substantially constant along the heel region **912** beneath where the heel of a user's foot would be received within the upper **902**. The greatest height of the second gap height **972** defines a maximum second gap height **972A**. The rear spacing **942** also has a rear spacing volume **974** as defined by the upper outsole **930A**, the lower outsole **930B**, and an unseen boundary extending from and between the periphery of the lower outsole **930B** and the upper outsole **930A** in the heel region **912**.

In the rested state, the first longitudinal length **922** of the article of footwear **900** is greater than the second longitudinal length **970**, and the maximum first gap height **926** is smaller than the maximum second gap height **972**. In some embodiments, the maximum second gap height **972A** can be in a range from about 2.0 times to about 3.0 times the maximum first gap height **926A**. In some embodiments, the first longitudinal length **922** can be in a range from about 1.5 times to about 2.0 times the second longitudinal length **970**. In some embodiments, the front spacing volume is approximately the same as the rear spacing volume.

In a neutral state (not shown), when a user's foot is received within the upper **902** and the user is standing (i.e., no downward force is being applied to the article of footwear **900** other than the weight of the user), the front spacing volume **928** decreases due to the upper outsole **930A** being urged toward the lower outsole **930B** under the force of the weight of the user. In some embodiments, for example, the percentage decrease in the front spacing volume **928** from the rested state to the neutral state can be in a range of about 1 percent to about 20 percent, more preferably the percentage decrease in the front spacing volume **928** can be in a range of about 5 percent to about 10 percent. Additionally, the rear spacing volume **974** will be decreased in the neutral state. In some embodiments, for example, the percentage decrease of the rear spacing volume **974** from the rested state to the neutral state can be in a range of about 1 percent to about 50 percent, more preferably the percentage decrease in the rear spacing volume **974** can be in a range of about 10 percent to about 30 percent. Further, the middle portion **964** of the lower outsole **930B** contacts the upper outsole **930A** in the midfoot region **910** and provides additional support of the arch of the user when in the neutral state.

During use, in an active state, when the lower outsole **930B** is in contact with the ground and a user exerts a downward force in the forefoot region **908**, the downward force will urge the upper outsole **930A** toward the lower

outsole **930B** and further decrease the front spacing volume **928** while lengthening the first longitudinal length **922** and the latitudinal width **982**. In some embodiments, for example, the percentage decrease in the front spacing volume **928** from the rested state to the active state can be in a range of about 10 percent to about 100 percent, more preferably, the percentage decrease in the front spacing volume **928** can be in a range of about 50 percent to about 90 percent. Additionally, in the active state, if a user applies a force to the heel portion **912**, the rear spacing volume **974** will experience a percentage decrease from the rested state. For example, the percentage decrease can be in a range of about 90 percent to about 100 percent. Further, the middle portion **964** of the lower outsole **930B** can act as a fulcrum when in the active state. For example, a user can strike the heel portion **912** on the ground while walking or running and rotate the foot forward about the middle portion **964** in the midfoot region **910**, and continue rotating the foot forward, striking the forefoot region **908** on the ground.

The configuration of the outsole **930**, with the front spacing **940** and rear spacing **942** provided between the upper outsole **930A** and the lower outsole **930B**, can provide force absorption as a user exerts downward force onto the forefoot region **908** and the heel region **912**, respectively, of the article of footwear **900** and can also provide a spring effect as the downward force from the user is relieved. This can reduce the severity of the impact to a user's foot and leg joints during use.

As stated above, some combination of ground engaging members (e.g., spikes **944**, teeth **946**, and barbs **948**) can be provided on the outsole **930**. Looking at FIG. **26**, the distribution of spikes **944**, teeth **946**, and barbs **948** can be on both the upper outsole **930A** and the lower outsole **930B**. For example, spikes **944** and barbs **948** can extend from bottom surfaces **938**, **968** of the upper and lower outsoles **930A**, **930B** at the front portions **932**, **962**. Teeth **946** can be provided around the periphery of the front portion **932** of the upper outsole **930A** and barbs **948** can extend from the bottom surface **968** of the lower outsole **930B** at the rear portion **966**.

FIGS. **28-30** show another embodiment of an article of footwear **1000**. In many aspects, the article of footwear **1000** is similar to the article of footwear **900** described above and similar numbering in the **1000** series is used for the article of footwear **900**. For example, the article of footwear **1000** includes an upper **1002**, a top portion **1020**, and a sole structure **1004** with an outsole **1030**. The outsole **1030** may be a rigid plate formed from one or more materials to impart durability, wear-resistance, abrasion resistance, or traction to the sole structure **1004**. The outsole **1030** has an upper outsole **1030A** and a lower outsole **1030B**. The upper outsole **1030A** has a front portion **1032**, a middle portion **1034**, and a rear portion **1036** and the lower outsole **1030B** has a front portion **1062**, a middle portion **1064**, a rear portion **1066** with a terminal end **1060**, and has a cross-like shape with a center section **1080**. The upper **1002** defines a forefoot region **1008**, a midfoot region **1010**, and a heel region **1012**. The upper and lower outsoles **1030A**, **1030B** define a front spacing **1040**, a first longitudinal length **1022**, a latitudinal width **1082**, a curved length **1024**, a first gap height **1026** with a maximum first gap height **1026A**, a front spacing volume **1028**, a rear spacing **1042**, a second longitudinal length **1070**, a second gap height **1072** with a maximum second gap height **1072A**, and a rear spacing volume **1074**. Further, the article of footwear **1000** also includes a medial side **1016** corresponding to an inside portion of the article of footwear **1000** and a lateral side

US 11,974,630 B2

21

1018 corresponding to an outside portion of the article of footwear 1000. The lower outsole 1030B can be coupled to the upper outsole 1030A at a forefoot coupling point 1076, a medial coupling point 1084, a lateral coupling point 1086, and a midfoot coupling point 1078. Additionally, at least one ground engaging member (e.g., a spike 1044, a tooth 1046, or a barb 1048) can extend from either or both bottom surfaces 1038, 1068 of the upper and lower outsoles 1030A, 1030B.

In some aspects, however, the articles of footwear 900, 1000 differ from each other. For example, the sole structure 1004 includes a front cushioning member 1050. The front cushioning member 1050 may be positioned within the front spacing 1040 between the lower outsole 1030B and the upper outsole 1030A and can extend across the front portion 1062 of the lower outsole 1030B. In some embodiments, for example, the volume of the front cushioning member 1050 can be in a range of about 85 percent to about 95 percent of the front spacing volume 1028. The front cushioning member 1050 can be formed from any of the materials and processes described above with respect to the front cushioning member 250 of the article of footwear 200.

The sole structure 1004 as described with the front cushioning member 1050 provided within the front spacing 1040 of the outsole 1030 can provide spring and dampening properties. This can reduce the severity of the impact to a user's foot and leg joints during use. It is contemplated that the location of the lowest point of the center section 1080 (e.g., at the location of the maximum first gap height 1026A) can be positioned within the outsole 1030 depending on the running behavior of the athlete, such that the lowest point is always the first ground contact spot. Doing so can bundle the force and energy in a single spot rather than distributing the energy and force over the width of the outsole 1030. This could be especially beneficial for runners with flat feet or similar foot issues

FIGS. 31-33 show another embodiment of an article of footwear 1100. In many aspects, the article of footwear 1100 is similar to the article of footwear 1000 described above and similar numbering in the 1100 series is used for the article of footwear 1100. For example, the article of footwear 1100 includes an upper 1102, a top portion 1120, and a sole structure 1104 with an outsole 1130. The outsole 1130 may be a rigid plate formed from one or more materials to impart durability, wear-resistance, abrasion resistance, or traction to the sole structure 1104. The outsole 1130 has an upper outsole 1130A and a lower outsole 1130B. The upper outsole 1130A has a front portion 1132, a middle portion 1134, and a rear portion 1136 and the lower outsole 1030B has a front portion 1162, a middle portion 1164, and a rear portion 1166 with a terminal end 1160, and has a cross-like shape with a center section 1180. The upper 1102 defines a forefoot region 1108, a midfoot region 1110, and a heel region 1112. The upper and lower outsoles 1130A, 1130B define a front spacing 1140, a first longitudinal length 1122, a latitudinal width 1182, a curved length 1124, a first gap height 1126 with a maximum first gap height 1126A, a front spacing volume 1128, a rear spacing 1142, a second longitudinal length 1170, a second gap height 1172 with a maximum second gap height 1172A, and a rear spacing volume 1174. Further, the article of footwear 1100 also includes a medial side 1116 corresponding to an inside portion of the article of footwear 1100 and a lateral side 1118 corresponding to an outside portion of the article of footwear 1100. The lower outsole 1130B can be coupled to the upper outsole 1130A at a forefoot coupling point 1176, a medial coupling point 1184, a lateral coupling point 1186, and a midfoot coupling

22

point 1178. Additionally, at least one ground engaging member (e.g., a spike 1144, a tooth 1146, or a barb 1148) can extend from either or both bottom surfaces 1138, 1168 of the upper and lower outsoles 1130A, 1130B.

Further, the sole structure 1104 includes a front cushioning member 1150. The front cushioning member 1150 is positioned within the front spacing 1140 between the lower outsole 1130B and the upper outsole 1130A and extends across the lower outsole 1130B. The front cushioning member 1150 can be formed from any of the materials and processes described above with respect to the front cushioning member 250 of the article of footwear 200.

In some aspects, however, the articles of footwear 1000, 1100 differ from each other. For example, the sole structure 1104 includes a rear cushioning member 1152 similar to that of the front cushioning member 1050 in the article of footwear 1000. The rear cushioning member 1152 may be positioned within the rear spacing 1142 between the lower outsole 1130B and the upper outsole 1130A. The rear cushioning member 1152 extends across a portion of the rear portion 1166 of the lower outsole 1130B. In some embodiments, for example, the volume of the rear cushioning member 1152 can be in a range of about 35 percent to about 50 percent of the rear spacing volume 1174. In some embodiments, the rear cushioning member 1152 can define a rear spacing pocket 1154 adjacent the front side of the rear cushioning member 1152. The rear spacing pocket 1154 extends longitudinally between the midfoot coupling point 1178 and the rear cushioning member 1152, latitudinally between the medial side 1116 and the lateral side 1118, and vertically between the upper outsole 1130A and the lower outsole 1130B. As shown in FIGS. 31 and 33, the rear cushioning member 1152 is positioned directly beneath where the heel of a user's foot would be received within the upper 1102. For example, the rear cushioning member 1152 is positioned within the rear spacing pocket 1154 at the location of and adjacent the maximum second gap height 1172A. The rear cushioning member 1152 can be formed from any of the materials and processes described above with respect to the front cushioning member 250 of the article of footwear 200.

The sole structure 1104 as described with the front cushioning member 1150 provided within the front spacing 1140 of the outsole 1130 and the rear cushioning member 1152 provided within the rear spacing 1142 of the outsole 1130 can provide spring and dampening properties, which can reduce the severity of the impact to a user's foot and leg joints during use.

FIGS. 34-48 show other embodiments of an article of footwear 1200, 1300, 1400, 1500, 1600. In many aspects, the articles of footwear 1200, 1300, 1400, 1500, 1600 are similar to the articles of footwear 900, 1000, 1100 described above and similar numbering in the 1200, 1300, 1400, 1500, 1600 series is used for the articles of footwear 1200, 1300, 1400, 1500, 1600. For example, each of the articles of footwear 1200, 1300, 1400, 1500, 1600 include an upper 1202, 1302, 1402, 1502, 1602; a top portion 1220, 1320, 1420, 1520, 1620; and a sole structure 1204, 1304, 1404, 1504, 1604 with an outsole 1230, 1330, 1430, 1530, 1630. Each outsole 1230, 1330, 1430, 1530, 1630 may be a rigid plate and has an upper outsole 1230A, 1330A, 1430A, 1530A, 1630A with a front portion 1232, 1332, 1432, 1532, 1632; a middle portion 1234, 1334, 1434, 1534, 1634; and a rear portion 1236, 1336, 1436, 1536, 1636 and a lower outsole 1230B, 1330B, 1430B, 1530B, 1630B with a front portion 1262, 1362, 1462, 1562, 1662; a middle portion 1264, 1364, 1464, 1564, 1664; and a rear portion 1266,

1366, 1466, 1566, 1666 with a terminal end 1260, 1360, 1460, 1560, 1660. The upper outsole 1230A, 1330A, 1430A, 1530A, 1630A extends along the top portion 1220, 1320, 1420, 1520, 1620 and can be attached thereto. The lower outsole 1230B, 1330B, 1430B, 1530B, 1630B having a cross-like shape with a center section 1280, 1380, 1480, 1580, 1680. Additionally, each article of footwear 1200, 1300, 1400, 1500, 1600 defines a forefoot region 1208, 1308, 1408, 1508, 1608; a midfoot region 1210, 1310, 1410, 1510, 1610; and a heel region 1212, 1312, 1412, 1512, 1612 and has a medial side 1216, 1316, 1416, 1516, 1616 and a lateral side 1218, 1318, 1418, 1518, 1618. The lower outsole 1230B, 1330B, 1430B, 1530B, 1630B can be coupled to the upper outsole 1230A, 1330A, 1430A, 1530A, 1630A at a forefoot coupling point 1276, 1376, 1476, 1576, 1676; a medial coupling point 1284, 1384, 1484, 1584, 1684; a lateral coupling point 1286, 1386, 1486, 1586, 1686; and a midfoot coupling point 1278, 1378, 1478, 1578, 1678.

Further, each article of footwear 1200, 1300, 1400, 1500, 1600 defines a front spacing 1240, 1340, 1440, 1540, 1640; a first longitudinal length 1222, 1322, 1422, 1522, 1622; latitudinal width 1282, 1382, 1482, 1582, 1682; a curved length 1224, 1324, 1424, 1524, 1624; a first gap height 1226, 1326, 1426, 1526, 1626 with a maximum first gap height 1226A, 1326A, 1426A, 1526A, 1626A; a front spacing volume 1228, 1328, 1428, 1528, 1628; a rear spacing 1242, 1342, 1442, 1542, 1642; a second longitudinal length 1270, 1370, 1470, 1570, 1670; a second gap height 1272, 1372, 1472, 1572, 1672 with a maximum second gap height 1272A, 1372A, 1472A, 1572A, 1672A; and a rear spacing volume 1274, 1374, 1474, 1574, 1674. Each article of footwear 1200, 1300, 1400, 1500, 1600 also has at least one ground engaging member (e.g., a spike 1244, 1344, 1444, 1544, 1644; a tooth 1246, 1346, 1446, 1546, 1646; or a barb 1248, 1348, 1448, 1548) extending from at least one of a bottom surface 1238, 1338, 1438, 1538, 1638 of the upper outsole 1230A, 1330A, 1430A, 1530A, 1630A or a bottom surface 1268, 1368, 1468, 1568, 1668 of the lower outsole 1230B, 1330B, 1430B, 1530B, 1630B. However, each embodiment differs in the inclusion and arrangement of the front and rear cushioning members. When included, however, the materials comprising and processes for making the front and rear cushioning members are as described above.

In FIGS. 34-36, illustrating the article of footwear 1200, both a front cushioning member 1250 and a rear cushioning member 1252 are provided. The front cushioning member 1250 is positioned within the front spacing 1240 between the lower outsole 1230B and the upper outsole 1230A and extends across the front portion 1262 of the lower outsole 1230B. In some embodiments, for example, the volume of the front cushioning member 1250 can be in a range of about 85 percent to about 95 percent of the front spacing volume 1228. Further, the rear cushioning member 1252 is positioned within the rear spacing 1242 between the lower outsole 1230B and the upper outsole 1230A and extends across the rear portion 1266 of the lower outsole 1230B. In some embodiments, for example, the volume of the rear cushioning member 1252 can be in a range of about 70 percent to about 95 percent of the rear spacing volume 1274.

In FIGS. 37-39, the article of footwear 1300 is shown with both a front cushioning member 1350 and a rear cushioning member 1352. The front cushioning member 1350 is positioned within the front spacing 1340 between the lower outsole 1330B and the upper outsole 1330A and extends across a portion of the front portion 1362 of the lower outsole 1330B. In some embodiments, for example, the volume of the front cushioning member 1350 can be in a

range of about 35 percent to about 50 percent of the front spacing volume 1328. In some embodiments, the front cushioning member 550 can define a first front spacing pocket 1356 and a second front spacing pocket 1358 adjacent the front and rear sides of the front cushioning member 1350, respectively. The first front spacing pocket 1356 extends longitudinally between the forefoot coupling point 1376 and the front cushioning member 1350, latitudinally between the medial side 1316 and the lateral side 1318, and vertically between the upper outsole 1330A and the lower outsole 1330B. The second front spacing pocket 1358 extends longitudinally between the front cushioning member 1350 and the midfoot coupling point 1378, latitudinally between the medial side 1316 and the lateral side 1318, and vertically between the upper outsole 1330A and the lower outsole 1330B. As shown, the front cushioning member 1350 can be positioned directly beneath where the ball of a user's foot would be received within the upper 1302. For example, the front cushioning member 1350 is positioned within the front spacing pocket 1356 at the location of and adjacent the maximum first gap height 1326A. Further, the rear cushioning member 1352 is positioned within the rear spacing 1342 between the lower outsole 1330B and the upper outsole 1330A and extends across the rear portion 1366 of the lower outsole 1330B. In some embodiments, for example, the volume of the rear cushioning member 1352 can be in a range of about 70 percent to about 95 percent of the rear spacing volume 1374.

FIGS. 40-42 show the article of footwear 1400 with both a front cushioning member 1450 and a rear cushioning member 1452. The front cushioning member 1450 is positioned within the front spacing 1440 between the lower outsole 1430B and the upper outsole 1430A and extends across a portion of the front portion 1462 of the lower outsole 1430B. In some embodiments, for example, the volume of the front cushioning member 1450 can be in a range of about 35 percent to about 50 percent of the front spacing volume 1428. In some embodiments, the front cushioning member 1450 can define a first front spacing pocket 1456 and a second front spacing pocket 1458 adjacent the front and rear sides of the front cushioning member 1450, respectively. The first front spacing pocket 1456 extends longitudinally between the forefoot coupling point 1476 and the front cushioning member 1450, latitudinally between the medial side 1416 and the lateral side 1418, and vertically between the upper outsole 1430A and the lower outsole 1430B. The second front spacing pocket 1458 extends longitudinally between the front cushioning member 1450 and the midfoot coupling point 1478, latitudinally between the medial side 1416 and the lateral side 1418, and vertically between the upper outsole 1430A and the lower outsole 1430B. As shown, the front cushioning member 1450 can be positioned directly beneath where the ball of a user's foot would be received within the upper 1402. For example, the front cushioning member 1450 is positioned within the front spacing pocket 1456 at the location of and adjacent the maximum first gap height 1426A. The rear cushioning member 1452 is positioned within the rear spacing 1442 between the lower outsole 1430B and the upper outsole 1430A. The rear cushioning member 1452 extends across a portion of the rear portion 1466 of the lower outsole 1430B. In some embodiments, for example, the volume of the rear cushioning member 1452 can be in a range of about 35 percent to about 50 percent of the rear spacing volume 1474. In some embodiments, the rear cushioning member 1452 can define a rear spacing pocket 1454 adjacent the front side of the rear cushioning member 1452.

The rear spacing pocket 1454 extends longitudinally between the midfoot coupling point 1478 and the rear cushioning member 1452, latitudinally between the medial side 1416 and the lateral side 1418, and vertically between the upper outsole 1430A and the lower outsole 1430B. As shown, the rear cushioning member 1452 is positioned directly beneath where the heel of a user's foot would be received within the upper 1402. For example, the rear cushioning member 1452 is positioned within the rear spacing pocket 1454 at the location of and adjacent the maximum second gap height 1472A.

The article of footwear 1500 is shown in FIGS. 43-45. The article of footwear 1500 does not have a front cushioning member within the front spacing 1540 but does have a rear cushioning member 1552 within the rear spacing 1542. The rear cushioning member 1552 is positioned within the rear spacing 1542 between the lower outsole 1530B and the upper outsole 1530A. The rear cushioning member 1552 extends across a portion of the rear portion 1566 of the lower outsole 1530B. In some embodiments, for example, the volume of the rear cushioning member 1552 can be in a range of about 35 percent to about 50 percent of the rear spacing volume 1574. In some embodiments, the rear cushioning member can define a rear spacing pocket 1554 adjacent the front side of the rear cushioning member 1552. The rear spacing pocket 1554 extends longitudinally between the midfoot coupling point 1578 and the rear cushioning member 1552, latitudinally between the medial side 1516 and the lateral side 1518, and vertically between the upper outsole 1530A and the lower outsole 1530B. As shown, the rear cushioning member 1552 is positioned directly beneath where the heel of a user's foot would be received within the upper 1502. For example, the rear cushioning member 1552 is positioned within the rear spacing pocket 1554 at the location of and adjacent the maximum second gap height 1572A.

FIGS. 46-48 illustrate the article of footwear 1600. The article of footwear 1600 does not have a front cushioning member within the front spacing 1640 but does have a rear cushioning member 1652 within the rear spacing 1642. The rear cushioning member 1652 is positioned within the rear spacing 1642 between the lower outsole 1630B and the upper outsole 1630A and extends across the rear portion 1666 of the lower outsole 1630B. In some embodiments, for example, the volume of the rear cushioning member 1652 can be in a range of about 70 percent to about 95 percent of the rear spacing volume 1674.

FIGS. 49-59 illustrates the article of footwear 1700. In many aspects, the article of footwear 1700 is similar to the article of footwear 1400 described above and similar numbering in the 1700 series is used for the article of footwear 1700. For example, the article of footwear 1700 can include an upper 1702 (see FIGS. 54-59), a top portion 1720, and a sole structure 1704 with an outsole 1730. The upper 1702 defines a forefoot region 1708, a midfoot region 1710, and a heel region 1712. Further, the article of footwear 1700 also includes a medial side 1716 corresponding to an inside portion of the article of footwear 1700 and a lateral side 1718 corresponding to an outside portion of the article of footwear 1700. Additionally, the sole structure 1704 includes an outsole 1730, which may be a rigid plate formed from one or more materials to impart durability, wear-resistance, abrasion resistance, or traction to the sole structure 1704. The outsole 1730 has an upper outsole 1730A and a lower outsole 1730B, the space therebetween in the forefoot and heel regions 1708, 1712 defining a front spacing 1740 and a rear spacing 1742, respectively. The upper

outsole 1730A has a front portion 1732, a middle portion 1734, and a rear portion 1736 and the lower outsole 1730B has a front portion 1762, and a rear portion 1766. The upper outsole 1730 extends along the top portion 1720 and can be attached thereto. A front cushioning member 1750 is located in the front spacing 1740, and the front spacing 1740 further defines a first longitudinal length 1722, a curved length 1724, a first gap height 1726 with a maximum first gap height 1726A, and a front spacing volume 1728. A rear cushioning member 1752 is located in the rear spacing 1742, and the rear spacing 1742 further defines a second longitudinal length 1770, a second gap height 1772 with a maximum second gap height 1772A, and a rear spacing volume 1774.

In some aspects, however, the articles of footwear 1700, 1400 differ from each other. For example, the lower outsole 1730B is formed from a front lower outsole segment 1790 and a rear lower outsole segment 1792 coupled to the upper outsole 1730A at the front portion 1732 and the rear portion 1736, respectively. Further, at least one ground engaging member (e.g., a large spike 1744 or a small spike 1794) can extend from the bottom surface 1768 of the lower outsole 1730B.

Additionally, the structure of the outsole 1730, including the coupling of the upper and lower outssoles 1730A, 1730B, is different. For example, the front lower outsole segment 1790 of the lower outsole 1730B extends outward from the periphery of the front portion 1732 of the upper outsole segment 1730A and curves downward and then inward to extend at least partially beneath the upper outsole 1730A to form the front spacing 1740. In some embodiments, the front lower outsole segment 1790 can be formed as a set of fingers, or claws 1790A (e.g., lobes), that do not extend across the entire front spacing 1740 as shown in FIGS. 49-51. Further, the front spacing volume 1728 is defined by the upper outsole 1730A, the front lower outsole segment 1790, and an unseen boundary extending from and between the set of claws of the front lower outsole segment 1790. The front cushioning member 1750 is located at least substantially within the front spacing 1740, enclosed by the set of claws 1790A. In some embodiments, the front cushioning member 1750 can extend beyond the front spacing 1742 toward the rear portion 1736. In some embodiments, for example, the volume of the front cushioning member 1750 can be in a range of about 50 percent to about 75 percent of the front spacing volume 1728. In some embodiments, the front cushioning member 1750 can define a front spacing pocket 1756 between the curved portions of the front lower outsole segment 1790 and the periphery of the front cushioning member 1750. In some embodiments, the front cushioning member 1750 can extend downward between the set of fingers and in line with the front lower outsole segment 1790 (see FIGS. 52 and 55-57).

Looking at the rear lower outsole segment 1792, some differences from the lower outsole 1430B of the article of footwear 1400 are also present. The rear lower outsole segment 1792 of the lower outsole 1730B extends outward from the periphery of the rear portion 1736 of the upper outsole segment 1730A and curves downward and then inward to extend at least partially beneath the upper outsole 1730A to form the rear spacing 1742. In some embodiments, the rear lower outsole segment 1792 can be formed as a set of fingers, or claws 1792A, that do not extend across the entire rear spacing 1742 as shown in FIGS. 49-51. Further, the rear spacing volume 1774 is defined by the upper outsole 1730A, the rear lower outsole segment 1792, and an unseen boundary extending from and between the set of claws

1792A of the rear lower outsole segment 1792. The rear cushioning member 1752 is received within the rear spacing 1744. In some embodiments, the rear cushioning member 1752 can extend beyond the rear spacing 1744 toward the front portion 1732. In some embodiments, for example, the volume of the rear cushioning member 1752 can be in a range of about 50 percent to about 75 percent of the rear spacing volume 1774. In some embodiments, the rear cushioning member 1752 can define a rear spacing pocket 1754 between the curved portions of the rear lower outsole segment 1792 and the periphery of the rear cushioning member 1752. In some embodiments, the rear cushioning member 1752 can extend downward between the set of fingers and in line with the rear lower outsole segment 1792 (see FIGS. 53 and 59).

While running, the sets of claws 1790A, 1792A can partially collapse into the front cushioning member 1750 and the rear cushioning member 1752, respectively. The resiliency of the front and rear cushioning members 1750, 1752 and the sets of claws 1790A, 1792A, can provide additional energy return to a user. Each of the claws of the sets of claws 1790A, 1792A can be independently movable relative to the other claws.

Additionally, or alternatively, the sets of claws 1790A, 1792A can be coupled together via an additional plate (not shown) positioned between the front and rear cushioning members 1750, 1752 and the sets of claws 1790A, 1792A. The plate can be formed from a material such as TPU. While running, the sets of claws 1790A, 1792A can collapse into the plate and displace the force across the front and rear cushioning members 1750, 1752.

FIGS. 49-51 and 58 further illustrate the upper outsole 1730A including a set of ribs 1796 protruding downward from a bottom surface 1738 of the upper outsole 1730 and extending from the front portion 1732 to the rear portion 1736. The set of ribs 1796 add rigidity to the upper outsole 1730A and can further aid in supporting the arch of a user's foot.

FIGS. 60-62 illustrate another embodiment of an article of footwear 1800. In many aspects, the article of footwear 1800 is similar to the article of footwear 600 described above and similar numbering in the 1800 series is used for the article of footwear 1800. For example, the article of footwear 1800 can include an upper 1802 (see FIG. 62), a top portion 1820, and a sole structure 1804 with an outsole 1830 spaced from the top portion 1820. The space between the top portion 1820 and the outsole 1830 in the forefoot and heel regions 1808, 1812 defining a front spacing 1840 and a rear spacing 1842, respectively. The upper 1802 defines a forefoot region 1808, a midfoot region 1810, and a heel region 1812. Further, the article of footwear 1800 includes a medial side 1816 corresponding to an inside portion of the article of footwear 1800 and a lateral side 1818 corresponding to an outside portion of the article of footwear 1800. Further, the outsole 1830 may be a rigid plate and has a front portion 1832, a middle portion 1834, and a rear portion 1836 with a terminal end 1860. The outsole 1830 can be coupled to the top portion 1820 at a midfoot coupling point 1878. A front cushioning member 1850 is located in the front spacing 1840, which further defines a first longitudinal length 1822, a curved length 1824, a first gap height 1826 with a maximum first gap height 1826A, a front spacing volume 1828, a first front spacing pocket 1856, and a second front spacing pocket 1858. A rear cushioning member 1852 is located in the rear spacing 1842, which further defines a second longitudinal length 1870, a second gap height 1872 with a maximum second gap height 1872A, a rear spacing

volume 1874, and a rear spacing pocket 1854. Further, spikes 1844 and teeth 1846 extend downward from a bottom surface 1838 of the outsole 1830.

In some aspects, however, the articles of footwear 1800, 600 differ from each other. For example, the front portion 1832 of the outsole 1830 extends beyond the top portion 1820 defining a toe gap 1898. Further, a set of small spikes 1894 can also extend from the bottom surface 1838 of the outsole 1830. As shown, the set of small spikes 1894 are provided in the front portion 1832 and the rear portion 1836, but other arrangements are contemplated, including having the set of small spikes 1894 in only one of either the front portion 1832 or the rear portion 1836. Additionally, the outsole 1830 includes a set of ribs 1896 protruding downward from the bottom surface 1838 of the outsole 1830 and extending from the front portion 1832 to the rear portion 1836. The set of ribs 1896 add rigidity to the outsole 1830 and can further aid in supporting the arch of a user's foot.

FIGS. 63-67 illustrate another embodiment of an article of footwear 1900. In many aspects, the article of footwear 1900 is similar to the article of footwear 1700 described above and similar numbering in the 1900 series is used for the article of footwear 1900. For example, the article of footwear 1900 can include an upper 1902 (see FIG. 66), a top portion 1920, and a sole structure 1904 with an outsole (first outsole segment 1930A) spaced from the top portion 1920. The first outsole segment 1930A extends along the top portion 1932 and can be attached thereto. The upper 1902 defines a forefoot region 1908, a midfoot region 1910, and a heel region 1912 (see FIG. 66). Further, the article of footwear 1900 also includes a medial side 1916 corresponding to an inside portion of the article of footwear 1900. Additionally, the first outsole segment 1930A has a front portion 1932, a middle portion 1934, and a rear portion 1936.

Continuing, the front portion 1932 of the first outsole segment 1930A in the forefoot region 1908 extends downward and then inward. The front portion 1932 of the first outsole segment 1930A extends at least partially beneath the top portion 1920. In some embodiments, the front portion 1932 can be formed as a set of fingers, or claws 1990A (e.g., lobes), that do not extend across the entire front spacing 1940.

In some aspects, however, the articles of footwear 1900, 1700 differ from each other. For example, the article of footwear 1900 has a second outsole segment 1930B with a front portion 1962, a middle portion 1964, and a rear portion 1966 with a terminal end 1960. The front portion 1962 of the second outsole segment 1930B is positioned adjacent and within the set of claws 1990A and beneath the top portion 1940. The set of claws 1990A of the first outsole segment 1930A and the front portion 1962 of the second outsole segment 1930B define a front spacing 1940. The front spacing 1940 defines a first longitudinal length 1922, a curved length 1924, a first gap height 1926 with a maximum first gap height 1926A, a front spacing volume 1928, a first front spacing pocket 1956, and a second front spacing pocket 1958. A front cushioning member 1950 is located in the front spacing 1940. The rear portion 1966 extends beneath the top portion 1920 in the heel region 1912 and defines a rear spacing 1942 therebetween. The rear spacing 1942 defines a second longitudinal length 1970, a second gap height 1972 with a maximum second gap height 1972A, a rear spacing volume 1974, and a rear spacing pocket 1954. The front portion 1962 is coupled to the front cushioning member 1950, the middle portion 1964 can be coupled to the

US 11,974,630 B2

29

top portion **1920** at a midfoot coupling point **1978** (see FIG. **66**), and the rear portion **1966** is coupled to a rear cushioning member **1952**.

Continuing, both the first outsole segment **1930A** and the second outsole segment **1930B** may be rigid plates formed from one or more materials to impart durability, wear-resistance, abrasion resistance, or traction to the sole structure **1904**. Further, as shown in the illustrated embodiment, a number of ground engaging members are provided on the first and second outsole segments **1930A**, **1930B**. Spikes **1944** and small spikes **1994** are provided extending from bottom surfaces **1938**, **1968A** in the front portions **1932**, **1962** of the first and second outsole segments **1930A**, **1930B**, and small spikes **1994** are provided extending from a bottom surface **1968B** in the rear portion **1966** of the second outsole segment **1930B**. It should be understood that other arrangements of ground engaging members, as described in the discussion of any of the other embodiments above, are contemplated.

In other embodiments, other configurations are possible. For example, certain features and combinations of features that are presented with respect to particular embodiments in the discussion above can be utilized in other embodiments and in other combinations, as appropriate. Further, any of the embodiments described herein may be modified to include any of the structures or methodologies disclosed in connection with other embodiments. Additionally, the present disclosure is not limited to articles of footwear of the type specifically shown. Still further, aspects of the articles of footwear of any of the embodiments disclosed herein may be modified to work with any type of footwear, apparel, or other athletic equipment.

As noted previously, it will be appreciated by those skilled in the art that while the invention has been described above in connection with particular embodiments and examples, the invention is not necessarily so limited, and that numerous other embodiments, examples, uses, modifications and departures from the embodiments, examples and uses are intended to be encompassed by the claims attached hereto. The entire disclosure of each patent and publication cited herein is incorporated by reference, as if each such patent or publication were individually incorporated by reference herein. Various features and advantages of the invention are set forth in the following claims.

INDUSTRIAL APPLICABILITY

Numerous modifications to the present invention will be apparent to those skilled in the art in view of the foregoing description. Accordingly, this description is to be construed as illustrative only and is presented for the purpose of enabling those skilled in the art to make and use the invention. The exclusive rights to all modifications which come within the scope of the appended claims are reserved.

We claim:

1. An article of footwear comprising:

an upper; and

a sole structure coupled to the upper and defining a ground engaging surface, the sole structure including:

a cushioning member coupled to the upper, and

an outsole coupled to the cushioning member, the outsole including a central portion extending across the sole structure from a lateral side to a medial side and a plurality of lobes extending outward from a periphery of the central portion, each of the plurality of lobes being independently movable relative to one another,

30

wherein the plurality of lobes includes a first plurality of lobes arranged along the medial side in a forefoot region and extending from the periphery of the central portion toward the medial side, and a second plurality of lobes arranged along a lateral side in the forefoot region and extending from the periphery of the central portion toward the lateral side, and

wherein the first plurality of lobes includes at least three lobes that define a first continuous undulation along the medial side of the sole structure and the second plurality of lobes includes at least three lobes that define a second continuous undulation along the lateral side of the sole structure.

2. The article of footwear of claim **1**, wherein the outsole includes a plurality of ground engaging elements including:

a plurality of removable spikes; and

a plurality of barbs that are integrally formed with the outsole.

3. The article of footwear of claim **2**, wherein each of the plurality of removable spikes include a conical tip and each of the plurality of barbs has a triangular pyramidal shape.

4. The article of footwear of claim **2**, wherein each of the plurality of lobes includes a single removable spike of the plurality of removable spikes and at least one barb of the plurality of barbs.

5. The article of footwear of claim **1**, wherein a first lobe of the first plurality of lobes is positioned directly across the central portion from a second lobe of the second plurality of lobes, the first lobe and the second lobe extending in opposite directions from one another at their respective connections with the central portion.

6. The article of footwear of claim **5**, wherein the plurality of lobes is positioned in a forefoot region of the sole structure.

7. The article of footwear of claim **1**, wherein the outsole defines an open area between the first plurality of lobes and the second plurality of lobes.

8. The article of footwear of claim **7**, wherein the cushioning member extends through the open area to define a portion of the ground engaging surface.

9. The article of footwear of claim **1**, wherein the outsole includes a rigid plate having:

a first portion in a forefoot region of the sole structure, the first portion extending across the forefoot region from a lateral side of the sole structure to a medial side of the sole structure,

a second portion in a midfoot region of the sole structure, and

a third portion in a heel region of the sole structure.

10. The article of footwear of claim **9**, wherein the second portion of the outsole includes a rib protruding from a bottom surface of the outsole, the rib extending in a direction between the first portion and the second portion of the outsole.

11. The article of footwear of claim **1**, wherein at least one of the plurality of lobes extends from a proximal end to a distal end, the proximal end being coupled to the central portion and positioned between the cushioning member and the upper, and the distal end positioned so that the cushioning member is between the distal end and the upper.

12. An article of footwear comprising:

an upper; and

a sole structure coupled to the upper and defining a ground engaging surface, the sole structure including:

a cushioning member coupled to the upper; and

an outsole coupled to the cushioning member, the outsole including a front outsole segment positioned in a fore-

US 11,974,630 B2

31

foot region and a midfoot region, and a rear outsole segment positioned in a heel region and discontinuous with the front outsole segment along the ground engaging surface, the front outsole segment including a medial segment with a first plurality of lobes arranged along a medial side of the sole structure and a lateral segment with a second plurality of lobes arranged along a lateral side of the sole structure,

wherein each of the first plurality of lobes and the second plurality of lobes includes at least two lobes that are disposed entirely within the forefoot region such that the outsole has a continuously undulating peripheral edge extending around a toe end of the sole structure from a lateral side to a medial side, and

wherein the continuously undulating peripheral edge defines at least four inflection points along the lateral side and at least four inflection points along the medial side within the forefoot region and the midfoot region.

13. The article of footwear of claim 12, wherein each lobe of the first plurality of lobes and the second plurality of lobes is independently moveable relative to one another to displace a force to the cushioning member.

14. The article of footwear of claim 12, wherein the front outsole segment is discontinuous along the ground engaging surface between the lateral side and the medial side such that the front outsole segment defines an open area between the lateral segment and the medial segment.

15. The article of footwear of claim 14, wherein the cushioning member extends across the open area.

16. The article of footwear of claim 12, wherein the front outsole segment includes a plurality of first ground engaging elements and a plurality of second ground engaging elements that are shaped differently from the first ground engaging elements.

17. The article of footwear of claim 16, wherein each of the first plurality of lobes and the second plurality of lobes includes a first ground engaging element of the plurality of first ground engaging elements.

18. The article of footwear of claim 16, wherein the rear outsole segment includes a plurality of third ground engaging elements that are shaped similarly to the second ground engaging members.

19. The article of footwear of claim 12, wherein the outsole includes:

a first portion in a forefoot region of the sole structure, the first portion extending across the forefoot region from a lateral side of the sole structure to a medial side of the sole structure, and

a second portion in the midfoot region of the sole structure, the second portion being devoid of lobes on at least one of the medial and the lateral side such that the second portion extends partially across the sole structure from the lateral side to the medial side.

20. The article of footwear of claim 19, wherein the outsole includes a plurality of ribs extending in a direction between a heel region and the forefoot region.

21. A sole structure for an article of footwear including an upper, the sole structure comprising:

a cushioning member extending through each of a forefoot region, a midfoot region, and a heel region; and an outsole that includes a plate coupled to the cushioning member, the plate including a front portion disposed in the forefoot region and extending through the midfoot region to a rear portion disposed in the heel region, the front portion including a first segment and a second segment extending outward from a periphery of the first segment so that the second segment bounds the first

32

segment to define an outermost periphery of the plate along each of a lateral side and a medial side, the second segment formed as a plurality of lobes and including a medial segment arranged along the medial side and a lateral segment arranged along the lateral side,

wherein each of the medial segment and the lateral segment includes a first lobe defining a first peak, a second lobe directly connected to the first lobe and defining a second peak, and a valley between the first peak and the second peak such that the first lobe and the second lobe define an undulating peripheral edge of the outsole.

22. The article of footwear of claim 21, wherein the first lobe and the second lobe are directly connected at the valley to define a single concave region between and bounded by the first peak and the second peak.

23. The article of footwear of claim 21, wherein at least one of the medial segment and the lateral segment further includes a third lobe defining a third peak and a second valley between one of the first peak and the second peak to define a continuous extension of the undulating peripheral edge of the outsole.

24. The sole structure of claim 21, wherein the plate extends continuously through each of the forefoot region, the midfoot region, and the heel region; and wherein the second segment is disposed within the forefoot region.

25. The sole structure of claim 21, wherein each of the plurality of lobes of the second segment is provided with one of a plurality of first ground engaging members and the first segment does not include the plurality of first ground engaging members.

26. The sole structure of claim 21, wherein the first lobe and the second lobe of the medial segment extend outwardly from the first segment toward the medial side of the sole structure, and

wherein the first lobe and the second lobe of the lateral segment extend outwardly from the first segment toward the lateral side of the sole structure.

27. The sole structure of claim 26, wherein the outsole defines an open area between the medial segment and the lateral segment, the cushioning member extending through the open area.

28. The sole structure of claim 27, wherein the first lobe of the medial segment and the first lobe of the lateral segment are arranged in an opposed configuration about the open area so that an apex of the first lobe of the medial segment is substantially aligned with an apex of the first lobe of the lateral segment along a longitudinal direction, and

wherein the second lobe of the medial segment and the second lobe of the lateral segment are arranged in an opposed configuration about the open area so that an apex of the second lobe of the medial segment is substantially aligned with an apex of the second lobe of the lateral segment along a longitudinal direction.

29. An article of footwear, comprising:

an upper; and

a sole structure coupled to the upper and defining a ground engaging surface, the sole structure including:

a cushioning member coupled to the upper and extending through each of a forefoot region, a midfoot region, and a heel region; and an outsole including a rigid plate having: a central segment; a medial segment that bounds the central segment on a medial side of the sole structure to define an

outermost periphery of the outsole along the medial side, the medial segment including a first plurality of lobes extending from a medial periphery of the central segment toward a medial side of the sole structure, each of the first plurality of lobes including a medial ground engaging member; and

- a lateral segment that bounds the central segment on a lateral side of the sole structure to define an outermost periphery of the outsole along the lateral side, the lateral segment including a second plurality of lobes extending from a lateral periphery of the central segment toward a lateral side of the sole structure, each of the second plurality of lobes including a lateral ground engaging member,

wherein an open area is defined between the lateral segment and the medial segment,

wherein the first plurality of lobes includes at least two lobes that define a first continuous undulation along the medial side of the sole structure and the second plurality of lobes includes at least two lobes that define a second continuous undulation along the lateral side of the sole structure,

wherein at least one of the first plurality of lobes is arranged in an opposed configuration with a corresponding one of the second plurality of lobes about the open area, and

wherein the cushioning member extends through the open area to define a portion of the ground engaging surface.

* * * * *

EXHIBIT D



US012016422B2

(12) **United States Patent**
Girard et al.

(10) **Patent No.:** **US 12,016,422 B2**
(45) **Date of Patent:** **Jun. 25, 2024**

(54) **ARTICLE OF FOOTWEAR HAVING A SOLE PLATE**

(58) **Field of Classification Search**
CPC ... A43B 13/122; A43B 13/127; A43B 13/145;
A43B 13/37; A43B 13/026; A43B 13/04;
(Continued)

(71) Applicant: **PUMA SE**, Herzogenaurach (DE)

(56) **References Cited**

(72) Inventors: **Romain Girard**, Lauf an der Pegnitz (DE); **Andreas Siegismund**, Rueckersdorf (DE); **Mauro Bonin**, Nuremberg (DE)

U.S. PATENT DOCUMENTS

5,611,152 A 3/1997 Richard
7,114,269 B2 10/2006 Meschan
(Continued)

(73) Assignee: **PUMA SE**, Herzogenaurach (DE)

(*) Notice: Subject to any disclaimer, the term of this patent is extended or adjusted under 35 U.S.C. 154(b) by 0 days.

FOREIGN PATENT DOCUMENTS

CN 101611953 U 12/2009
CN 202145942 U 2/2012
(Continued)

(21) Appl. No.: **18/101,992**

(22) Filed: **Jan. 26, 2023**

OTHER PUBLICATIONS

(65) **Prior Publication Data**

US 2023/0165336 A1 Jun. 1, 2023

European Search Report from corresponding European Patent Application No. 21 187 302.1 dated Dec. 8, 2021 (9 pages).

Primary Examiner — Bao-Thieu L. Nguyen

(74) Attorney, Agent, or Firm — Quarles & Brady LLP

Related U.S. Application Data

(63) Continuation of application No. 17/383,954, filed on Jul. 23, 2021.

(Continued)

(51) **Int. Cl.**

A43B 13/12 (2006.01)
A43B 13/02 (2022.01)

(Continued)

(52) **U.S. Cl.**

CPC A43B 13/122 (2013.01); A43B 13/127 (2013.01); A43B 13/145 (2013.01);

(Continued)

(57)

ABSTRACT

A sole structure for an article of footwear having an upper includes an outsole having a ground engaging surface and a midsole member disposed between the outsole and the upper. The midsole member has a pocket extending from a heel region to a forefoot region and a sole plate disposed within the pocket. The sole plate extends from the heel region into the forefoot region. In the heel region, the sole structure is shaped to define an entry region that is configured to increase contact at the ground engaging surface during a heel strike. The entry region defines an angled portion that is angled at an entry angle relative to a flat ground surface. The midsole member is a supercritical foam.

25 Claims, 28 Drawing Sheets

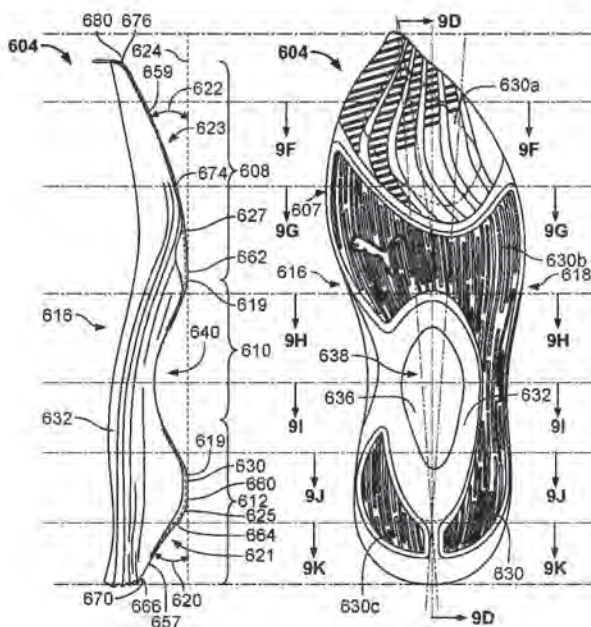

US 12,016,422 B2

Page 2

Related U.S. Application Data

(60) Provisional application No. 63/195,320, filed on Jun. 1, 2021, provisional application No. 63/055,506, filed on Jul. 23, 2020.

(51) Int. Cl.

A43B 13/04 (2006.01)

A43B 13/14 (2006.01)

A43B 13/37 (2006.01)

(52) U.S. Cl.

CPC *A43B 13/37* (2013.01); *A43B 13/026* (2013.01); *A43B 13/04* (2013.01)

(58) Field of Classification Search

CPC ... *A43B 13/146*; *A43B 13/183*; *A43B 13/185*; *A43B 13/186*; *A43B 13/12*; *A43B 13/181*; *A43B 13/187*

See application file for complete search history.

(56)

References Cited

U.S. PATENT DOCUMENTS

8,296,973 B2 10/2012 Roberti
8,307,569 B2 11/2012 McInnis
8,387,285 B2 3/2013 Hartveld
8,568,548 B2 10/2013 Park
8,969,453 B2 3/2015 Park
9,210,967 B2 12/2015 Gerber
9,591,891 B1 3/2017 Baucom
9,605,191 B2 3/2017 Park
9,936,765 B2 4/2018 Sato
9,961,959 B2 5/2018 Gerber
2002/0017036 A1 2/2002 Berger
2005/0026775 A1 2/2005 Grigsby
2008/0244932 A1 10/2008 Nau
2009/0019730 A1 1/2009 Salminen
2009/0119951 A1 5/2009 Hartveld
2010/0307032 A1 12/2010 Geer
2012/0079740 A1 4/2012 Zhou
2013/0205619 A1 8/2013 Hartveld

2016/0081427 A1 3/2016 Iuchi
2016/0353836 A1 12/2016 Luedecke
2016/0353838 A1 12/2016 Takeshita
2017/0095033 A1 4/2017 Farina
2018/0132564 A1* 5/2018 Bruce A43B 13/189
2018/0153254 A1 6/2018 Fusco
2018/0263335 A1 9/2018 Iuchi
2019/0150554 A1 5/2019 Strickland
2019/0150562 A1 5/2019 Bartel
2019/0200700 A1 7/2019 Hale
2019/0373982 A1 12/2019 Dupre
2019/0387837 A1 12/2019 Luh
2020/0121021 A1 4/2020 Bartel
2020/0383421 A1 12/2020 Bidal
2020/0383422 A1 12/2020 Bidal
2021/0137213 A1 5/2021 Stockbridge
2022/0053886 A1 2/2022 Bramani

FOREIGN PATENT DOCUMENTS

CN 109222324 A 1/2019
CN 209391167 U 9/2019
CN 212165086 U 12/2020
CN 212787628 U 3/2021
DE 112006002347 T5 7/2008
DE 102016118168 A1 11/2017
DE 112006002347 B4 7/2019
EP 3574787 A1 12/2019
GB 2288550 B 2/1998
GB 2425455 A 11/2006
GB 2431334 A 4/2007
GB 2431333 B 10/2010
GB 2437698 B 10/2010
GB 2499416 A 8/2013
JP 2509505 B2 6/1996
JP 6307728 B1 4/2018
JP 2021030079 A 3/2021
WO 2007026175 A1 3/2007
WO 2016132927 A1 8/2016
WO 2018137649 A1 8/2018
WO 2019204358 A1 10/2019

* cited by examiner

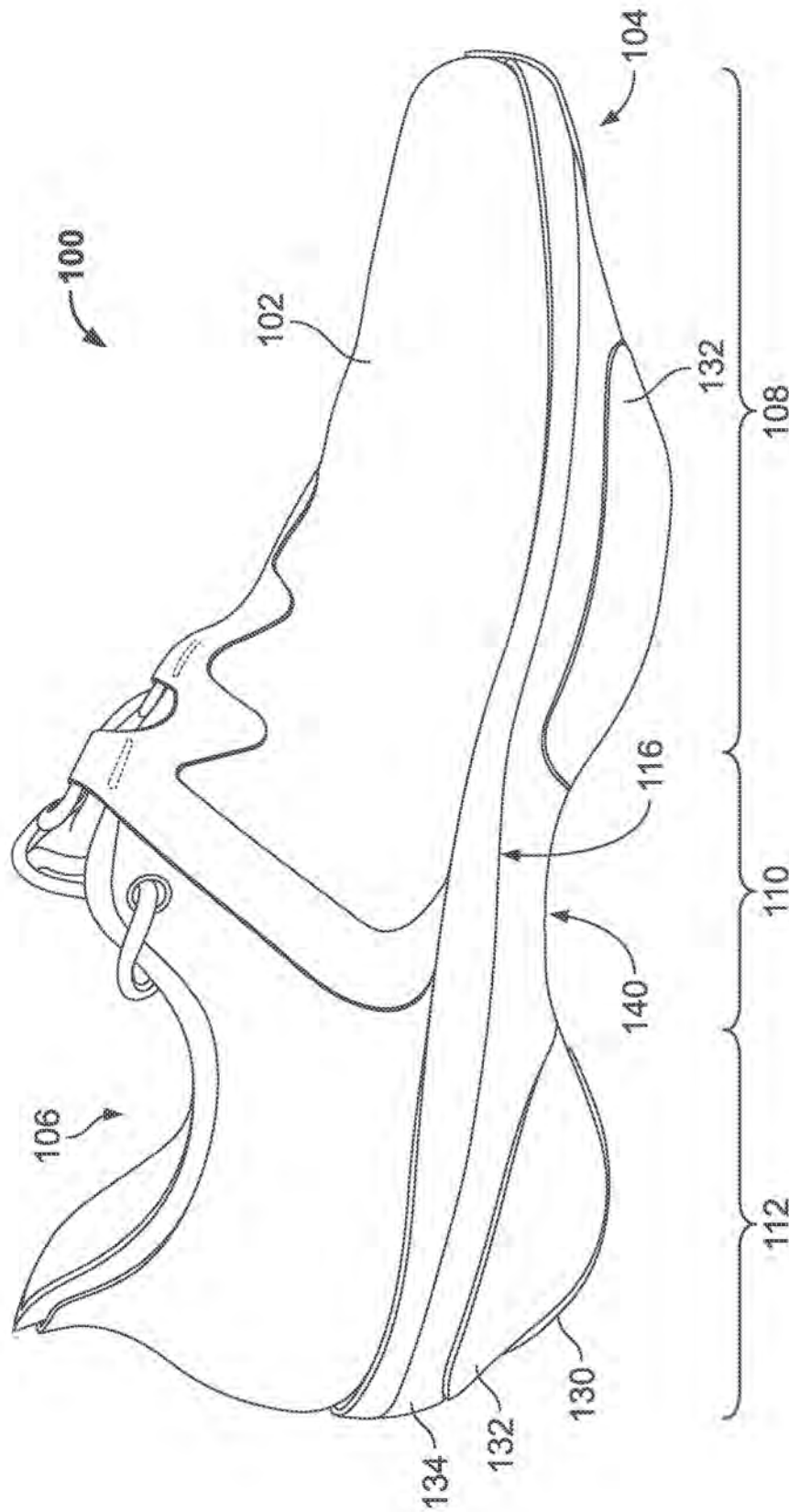

FIG. 1

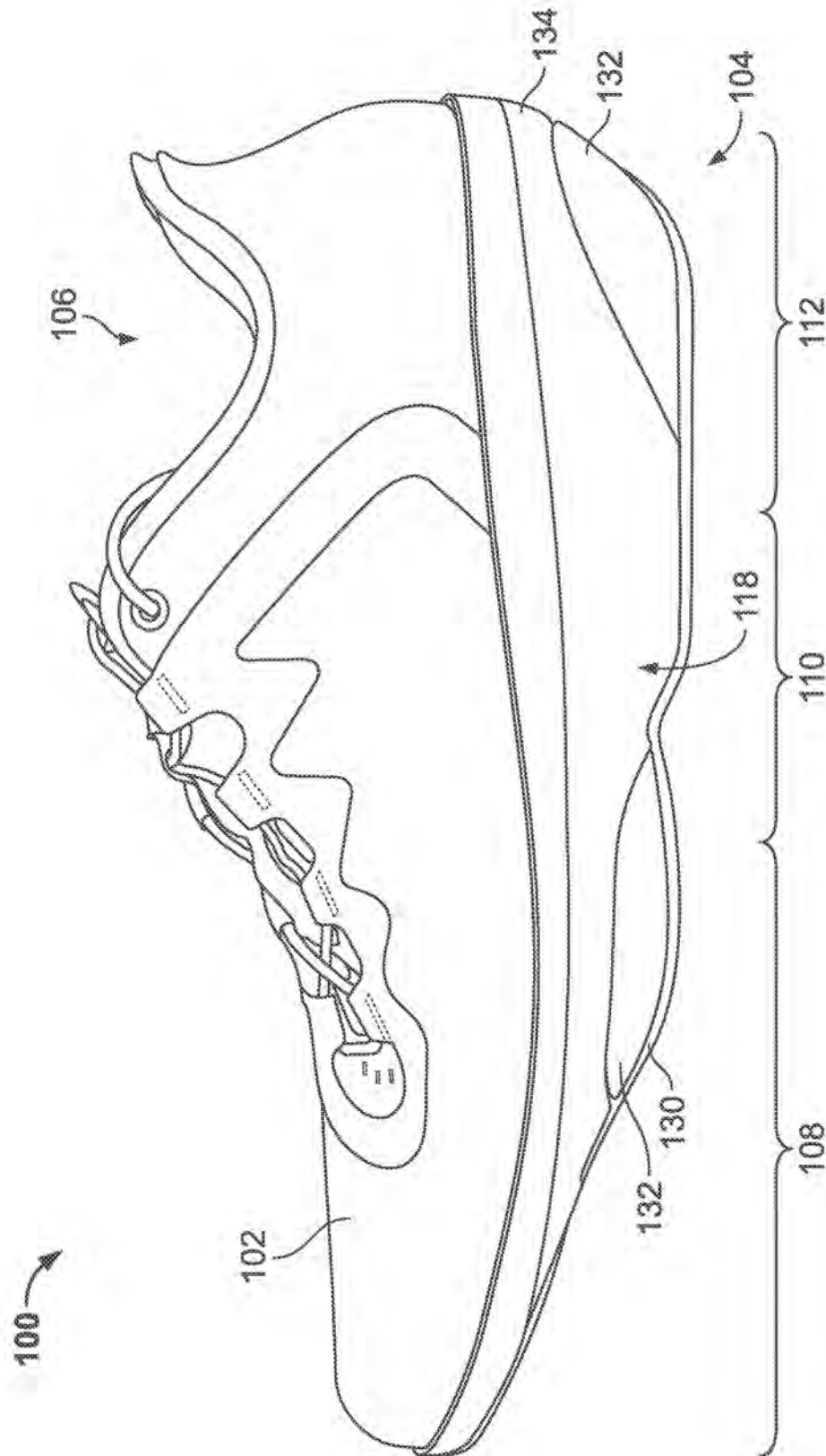
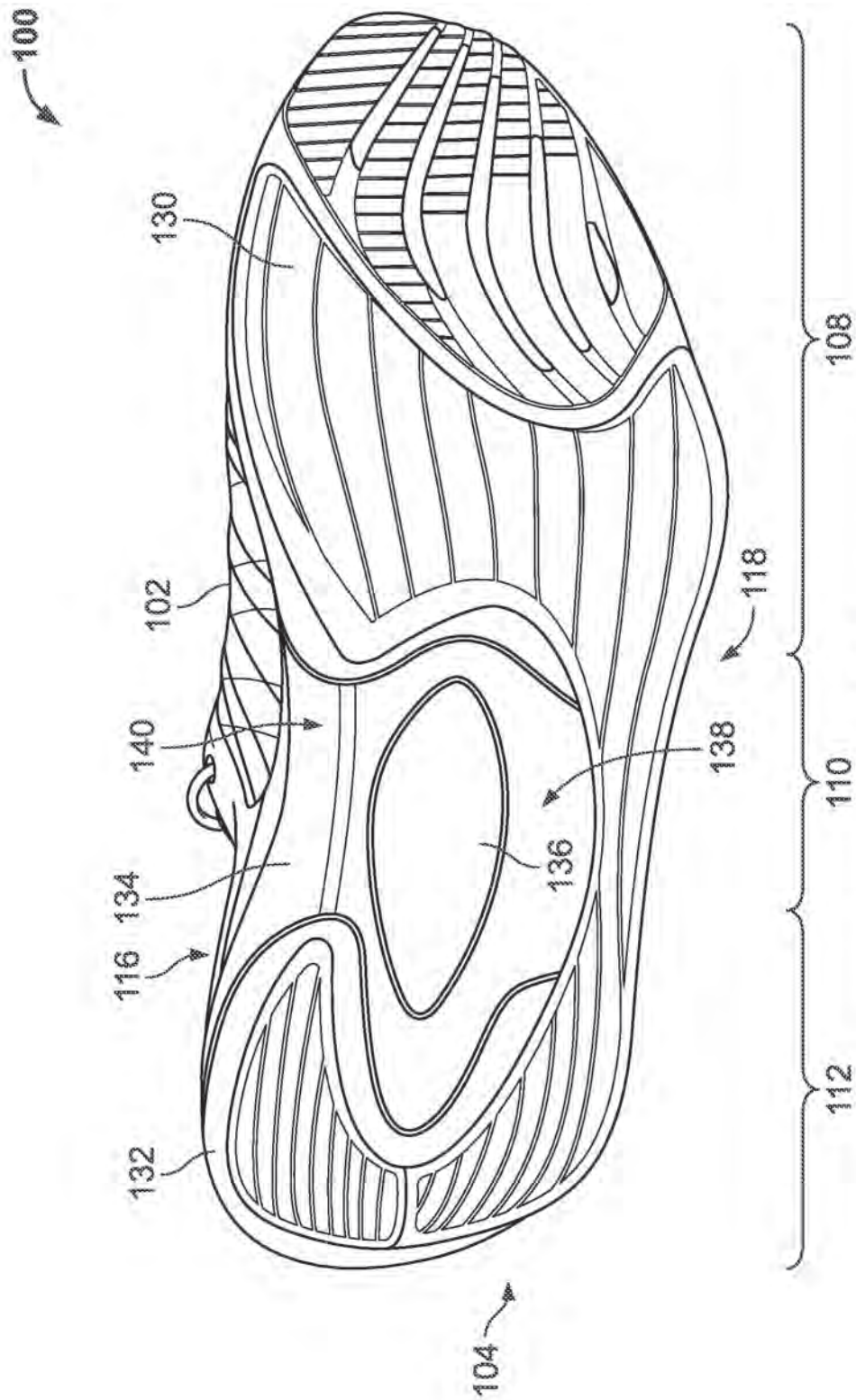

FIG. 2



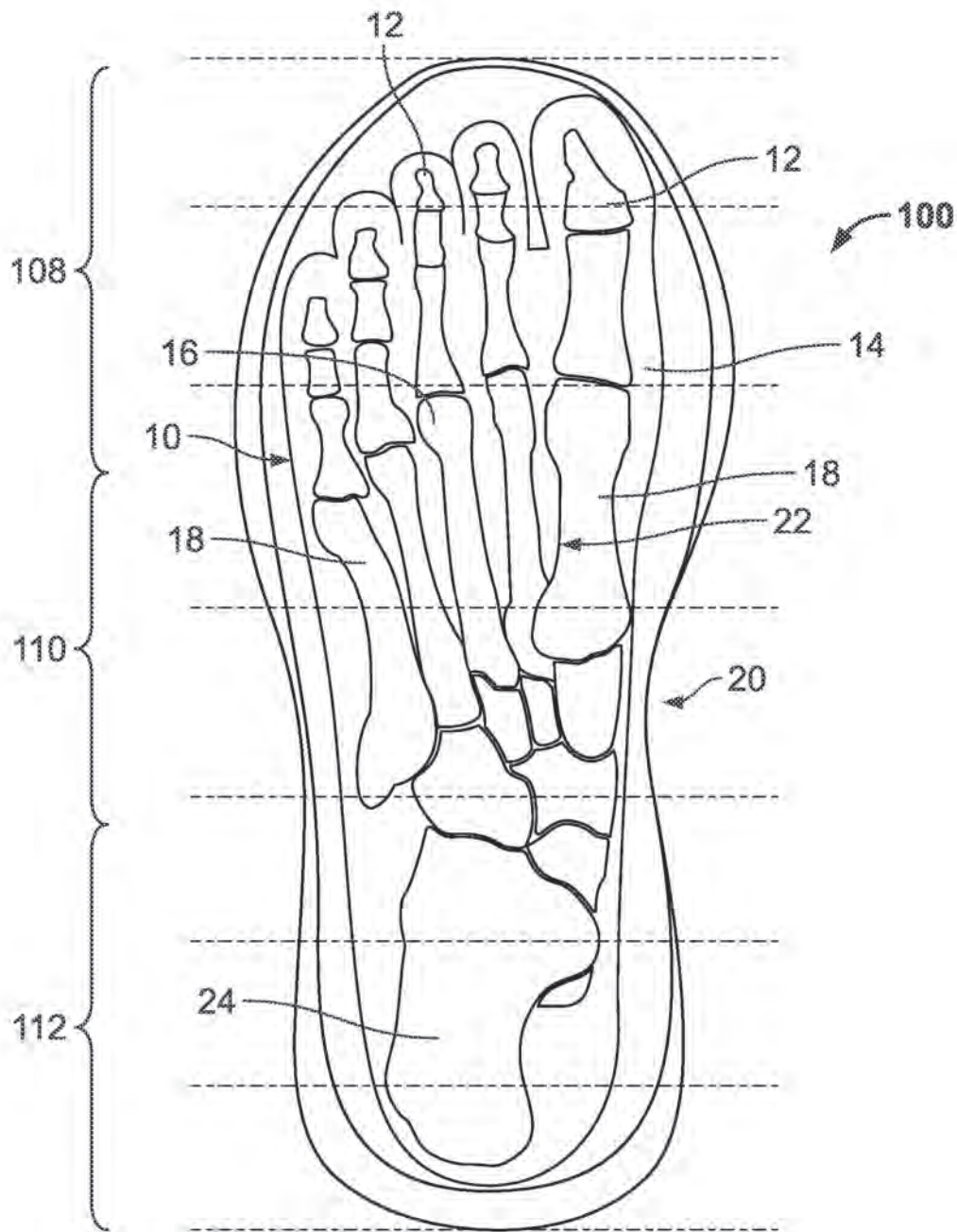
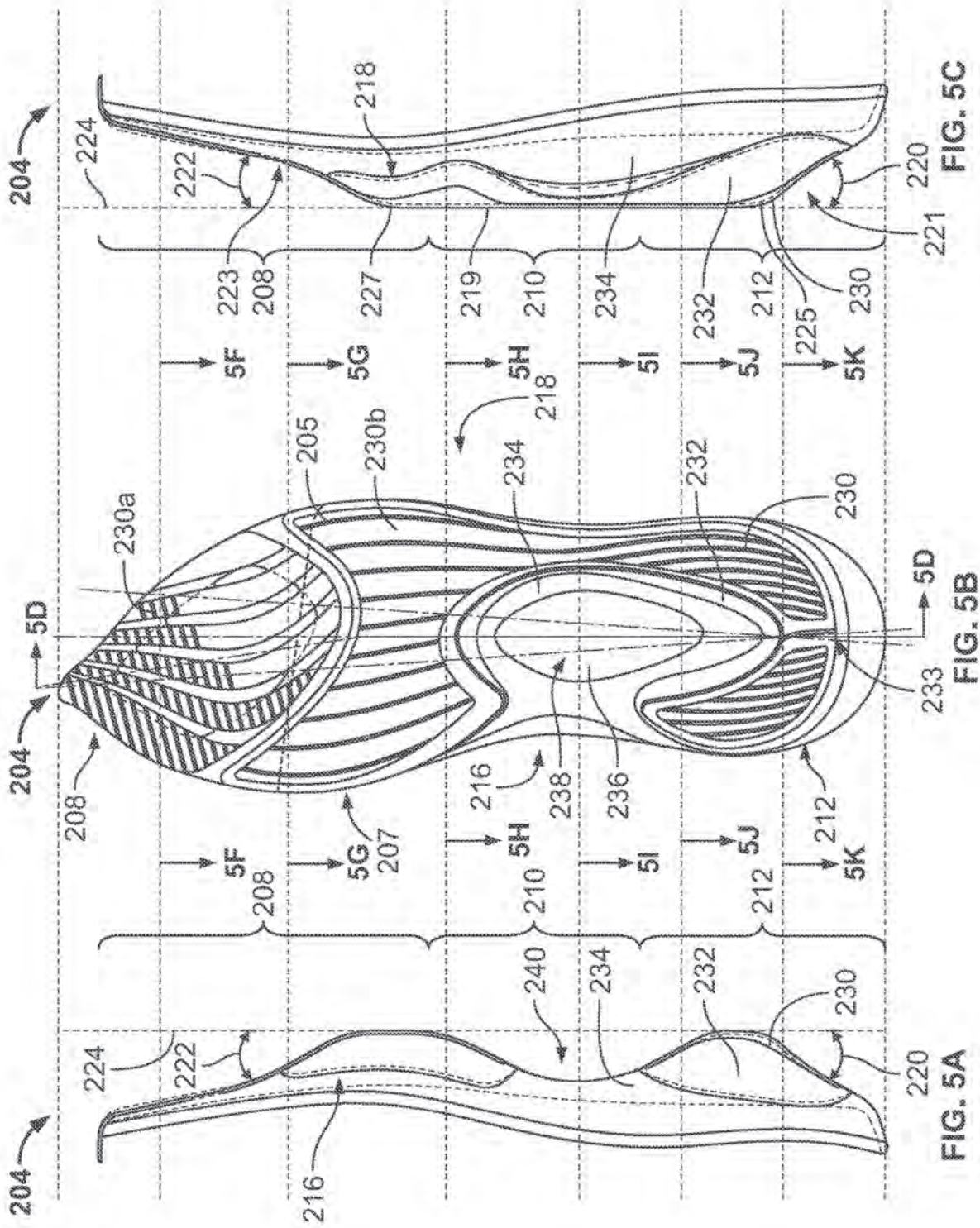

FIG. 4



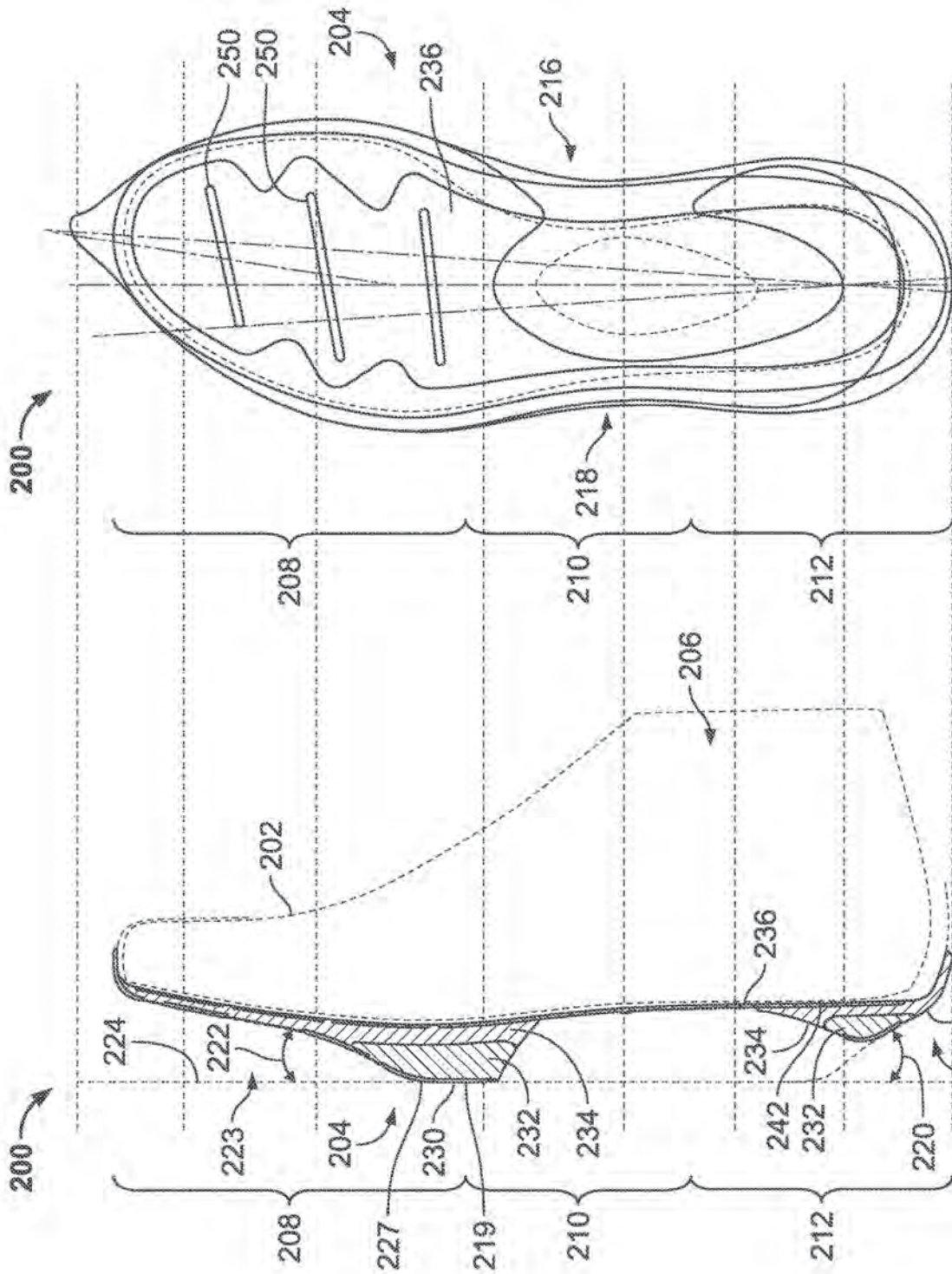

FIG. 5E

FIG. 5D

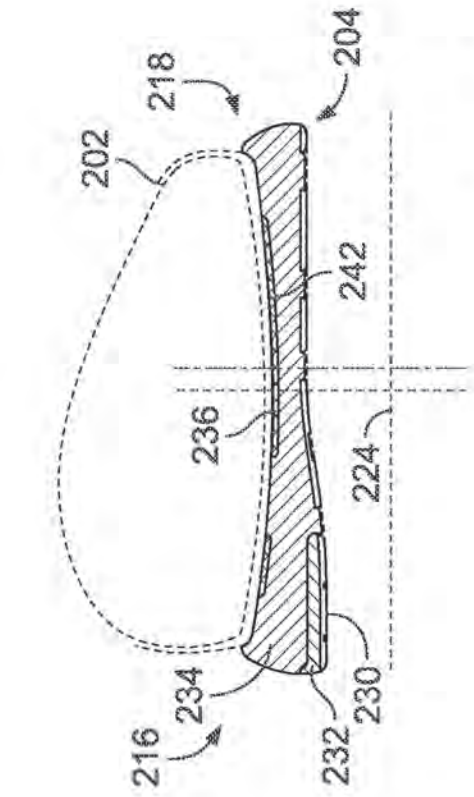

FIG. 5G

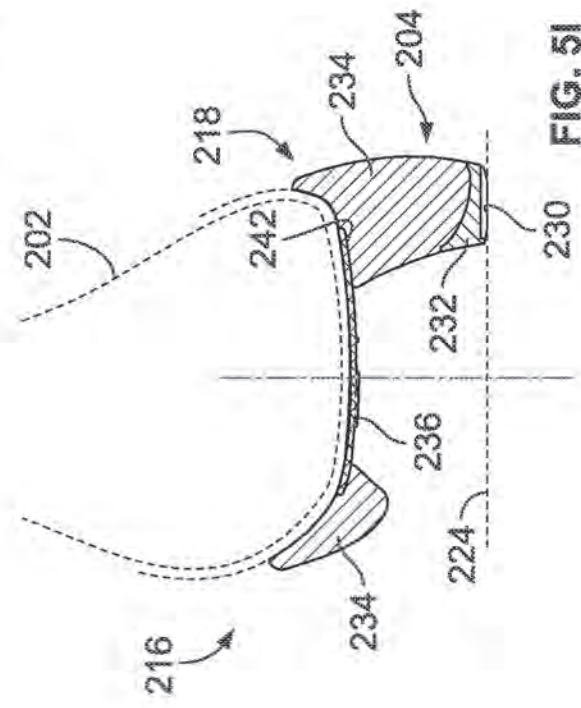

FIG. 5I

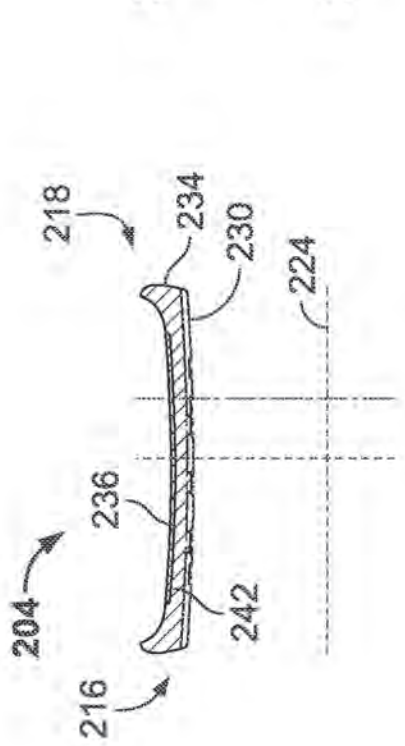

FIG. 5F

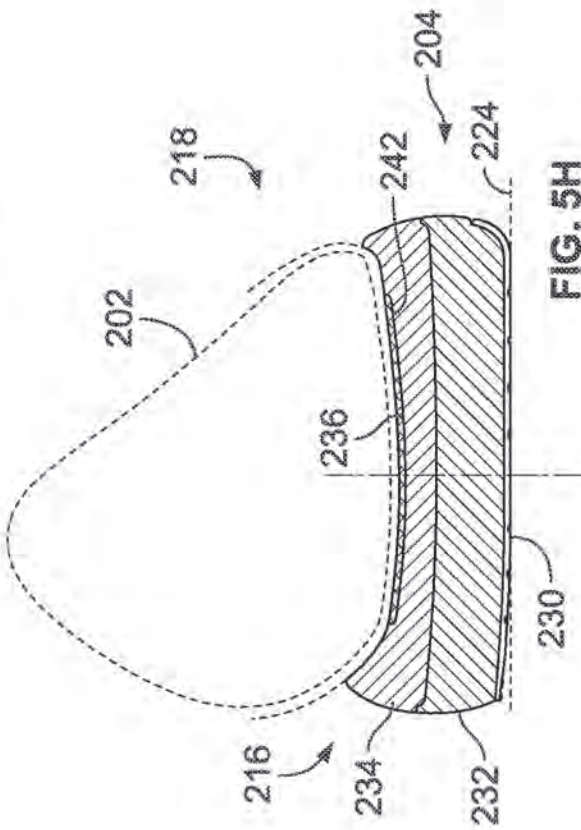

FIG. 5H

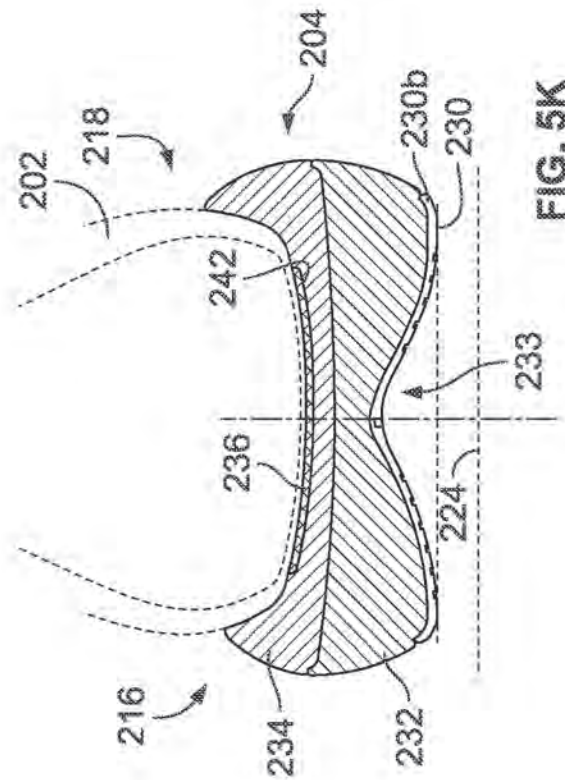

FIG. 5J

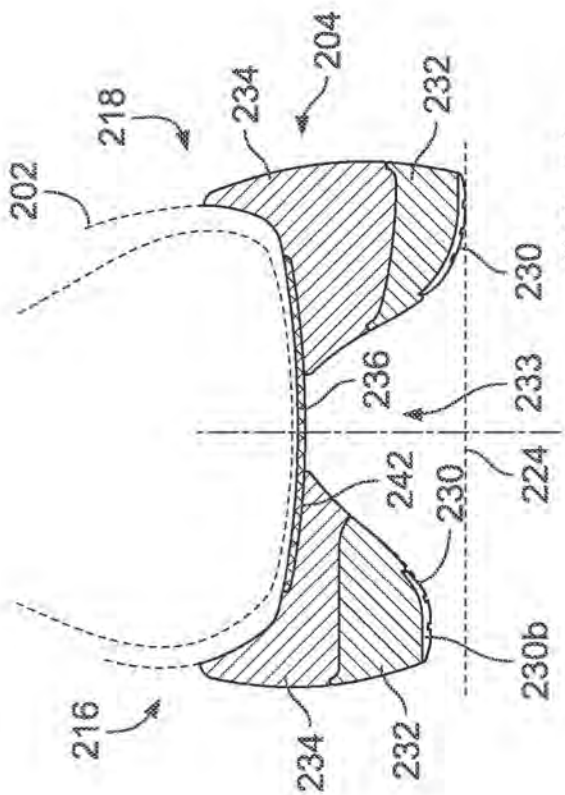

FIG. 5K

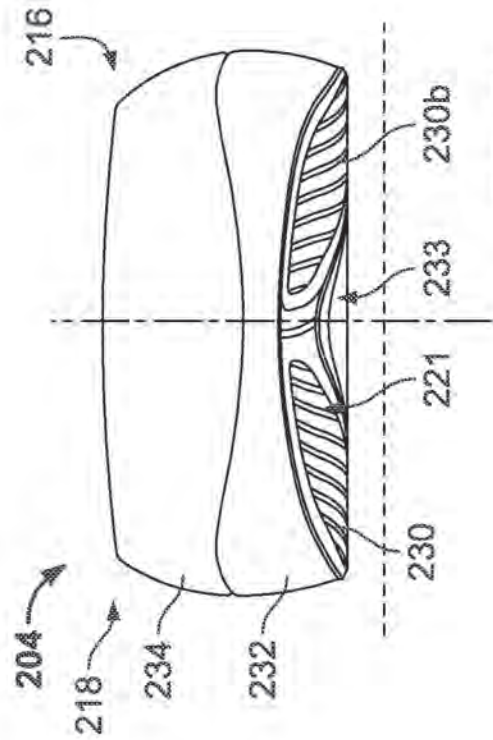

FIG. 5L

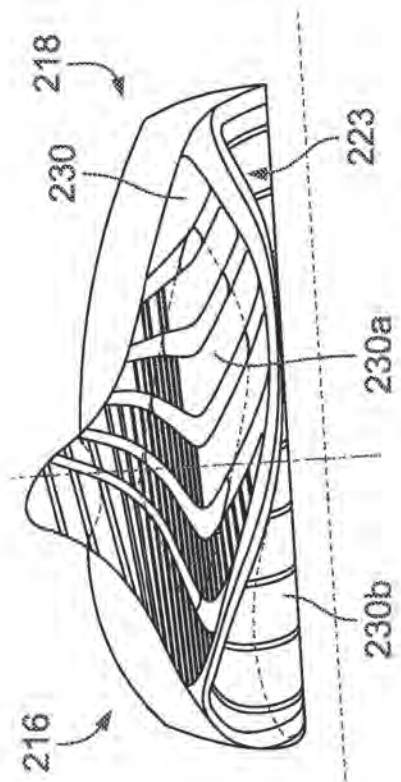

FIG. 5M

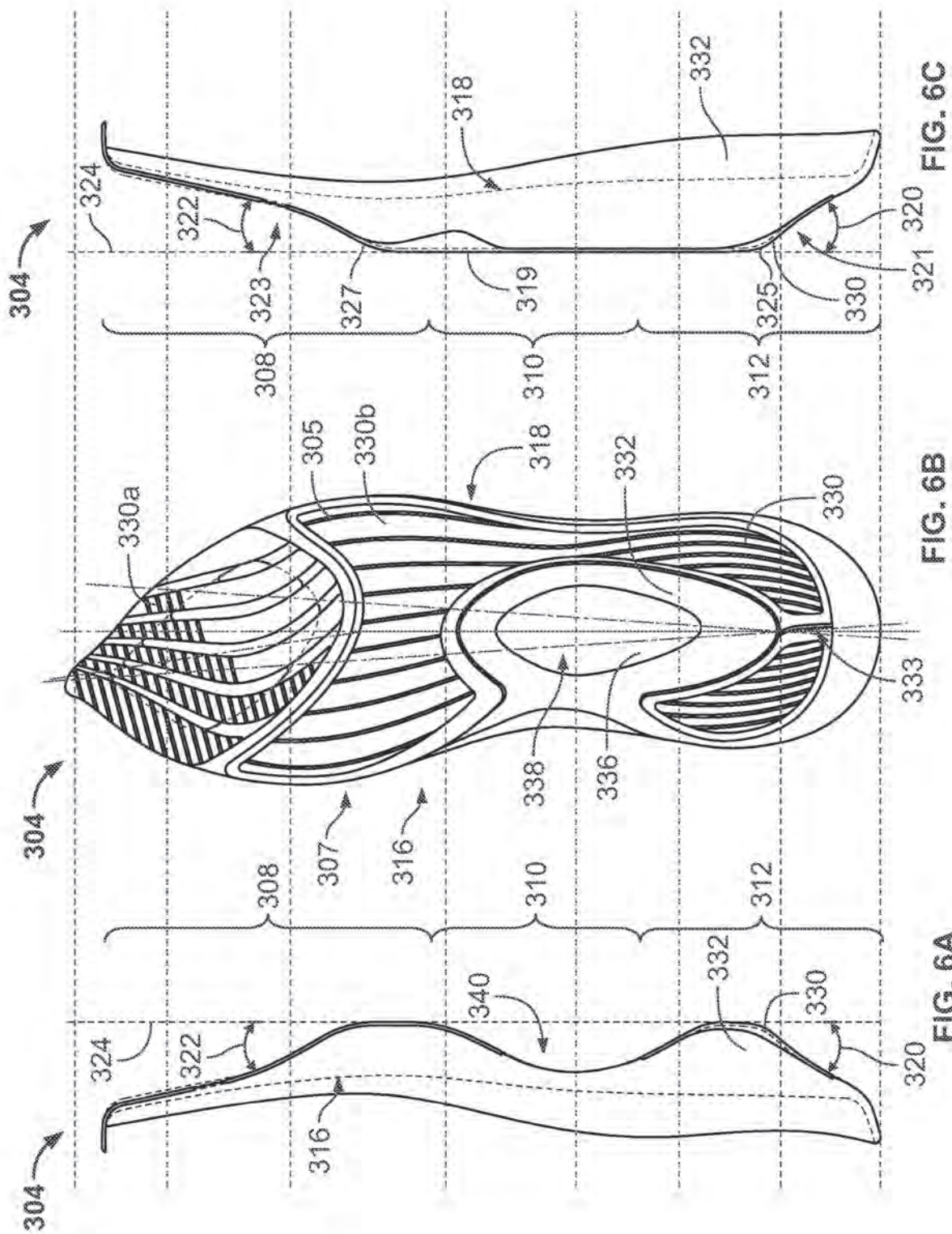

FIG. 6C

FIG. 6B

FIG. 6A

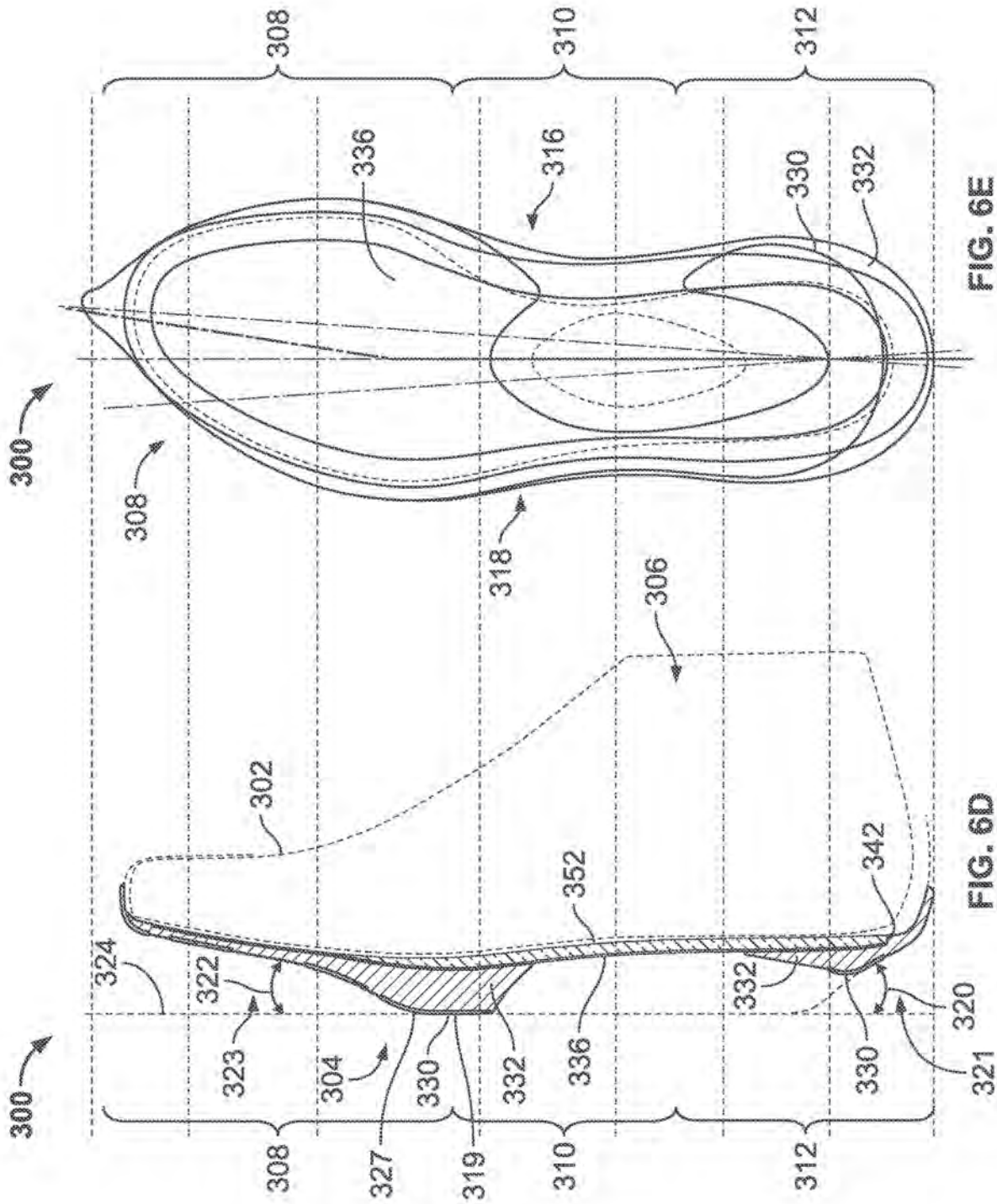

FIG. 6E

FIG. 6D

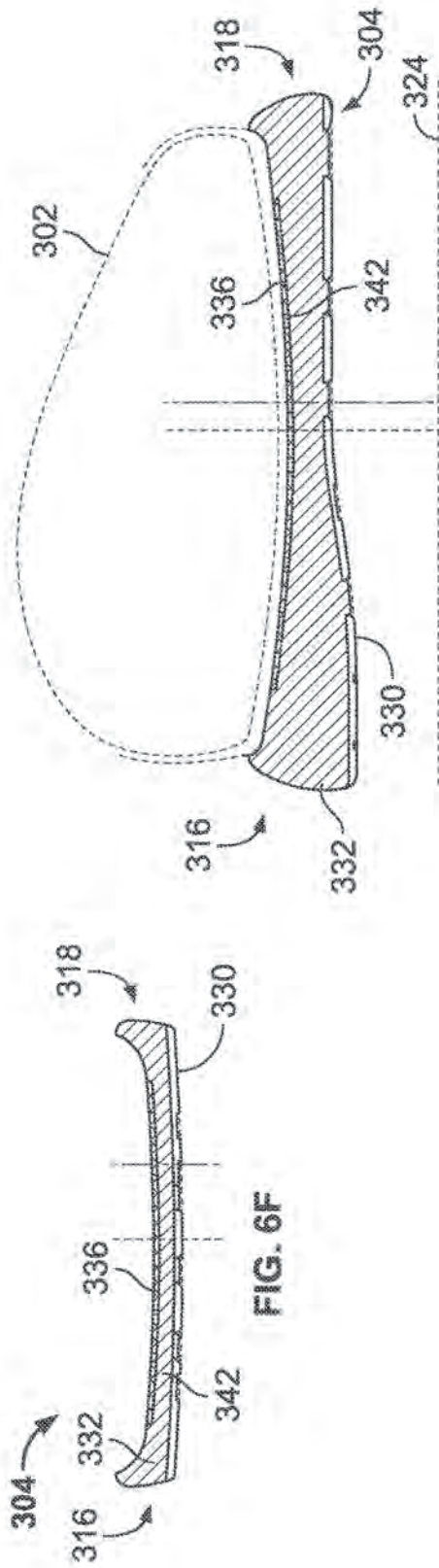

FIG. 6F

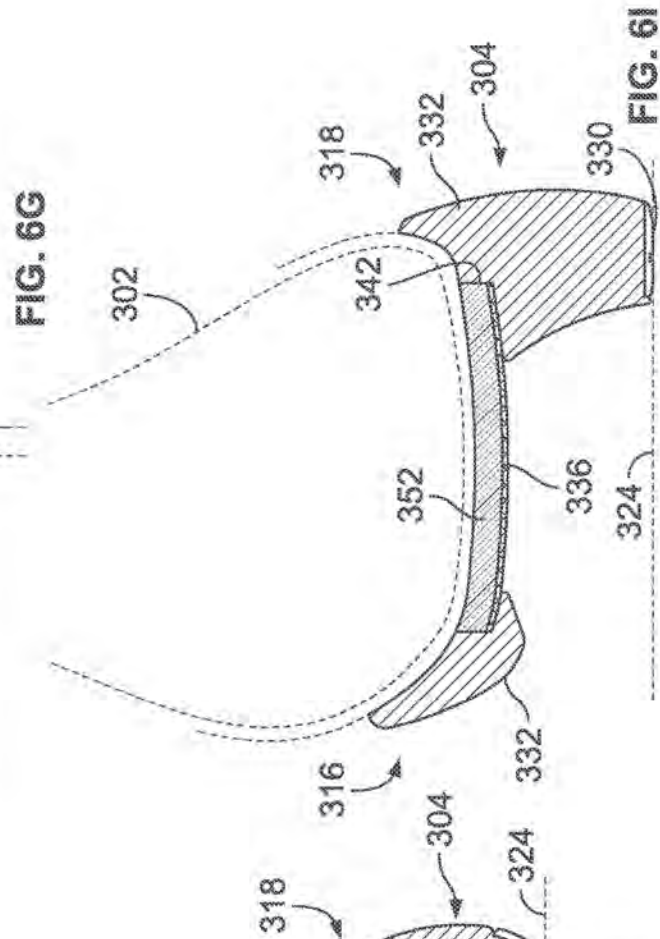

FIG. 6G

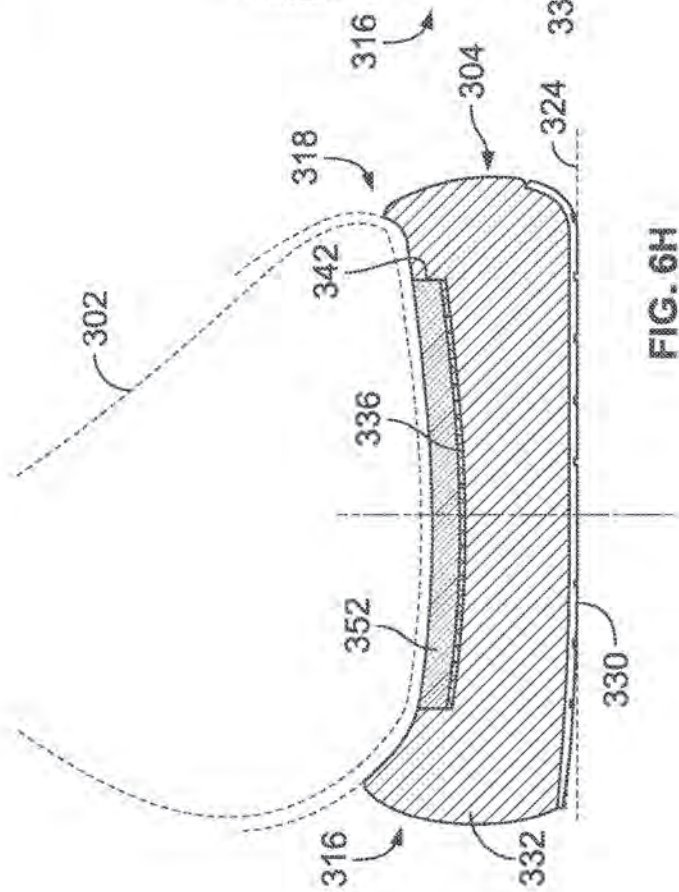

FIG. 6H

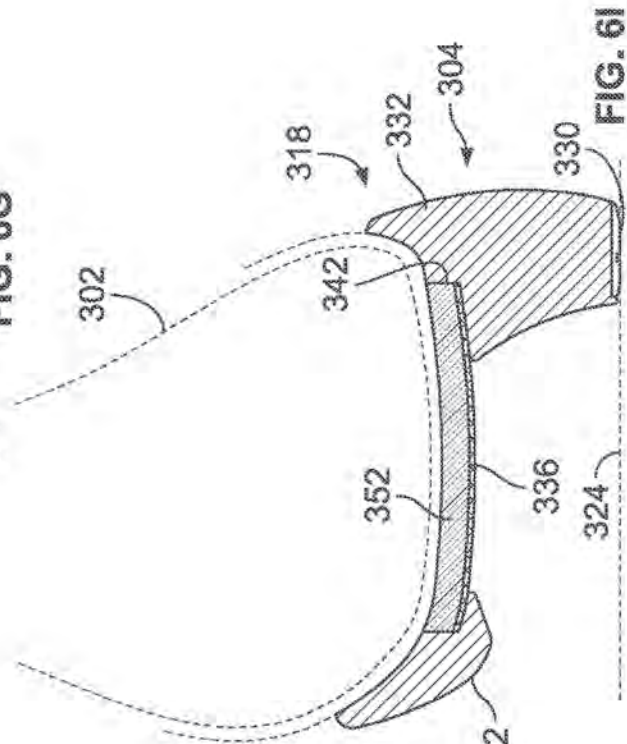

FIG. 6I

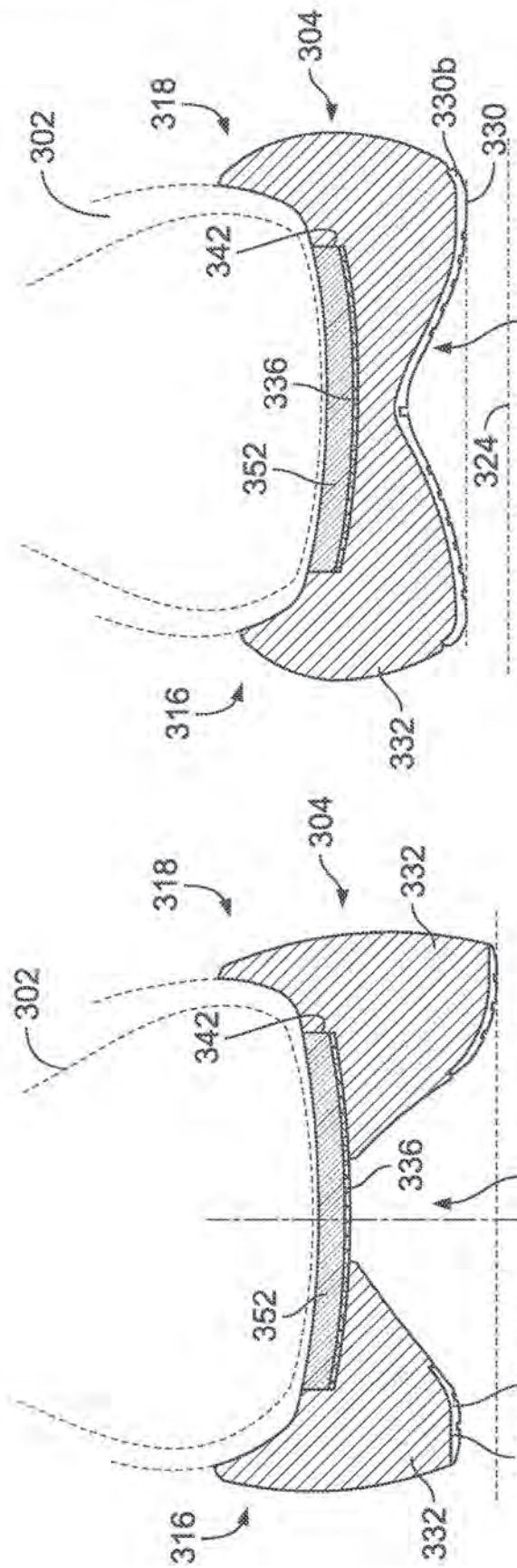

FIG. 6K

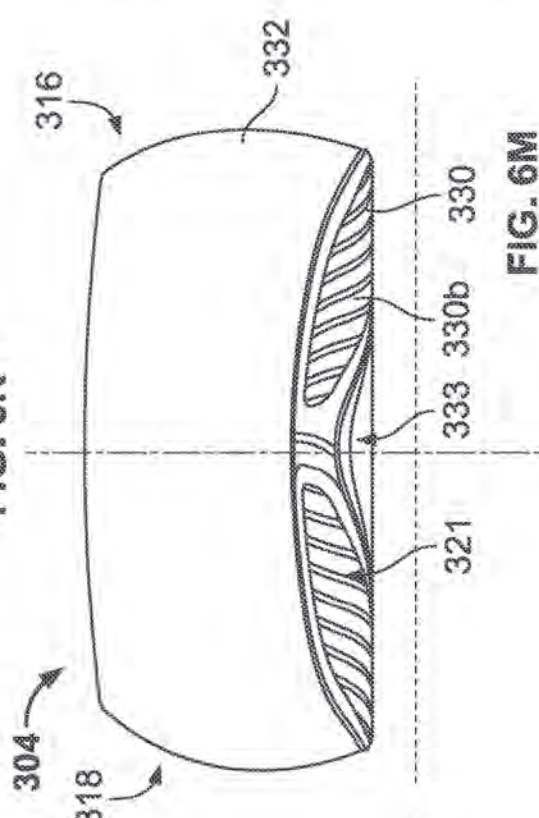

FIG. 6M

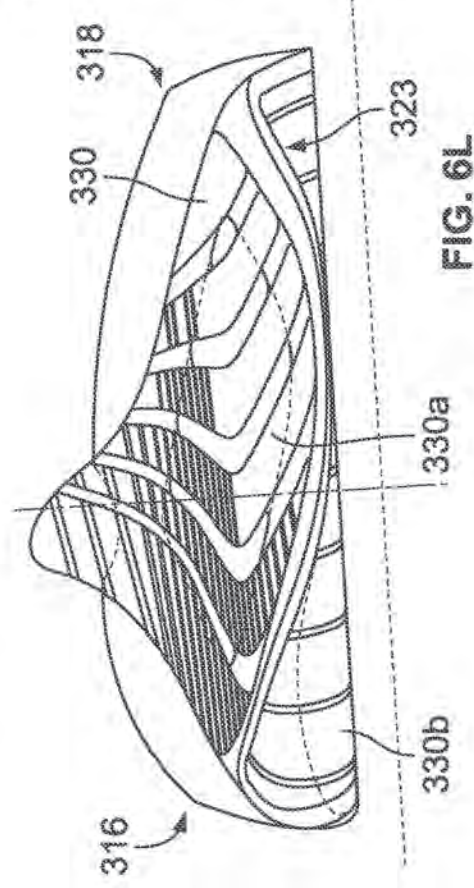
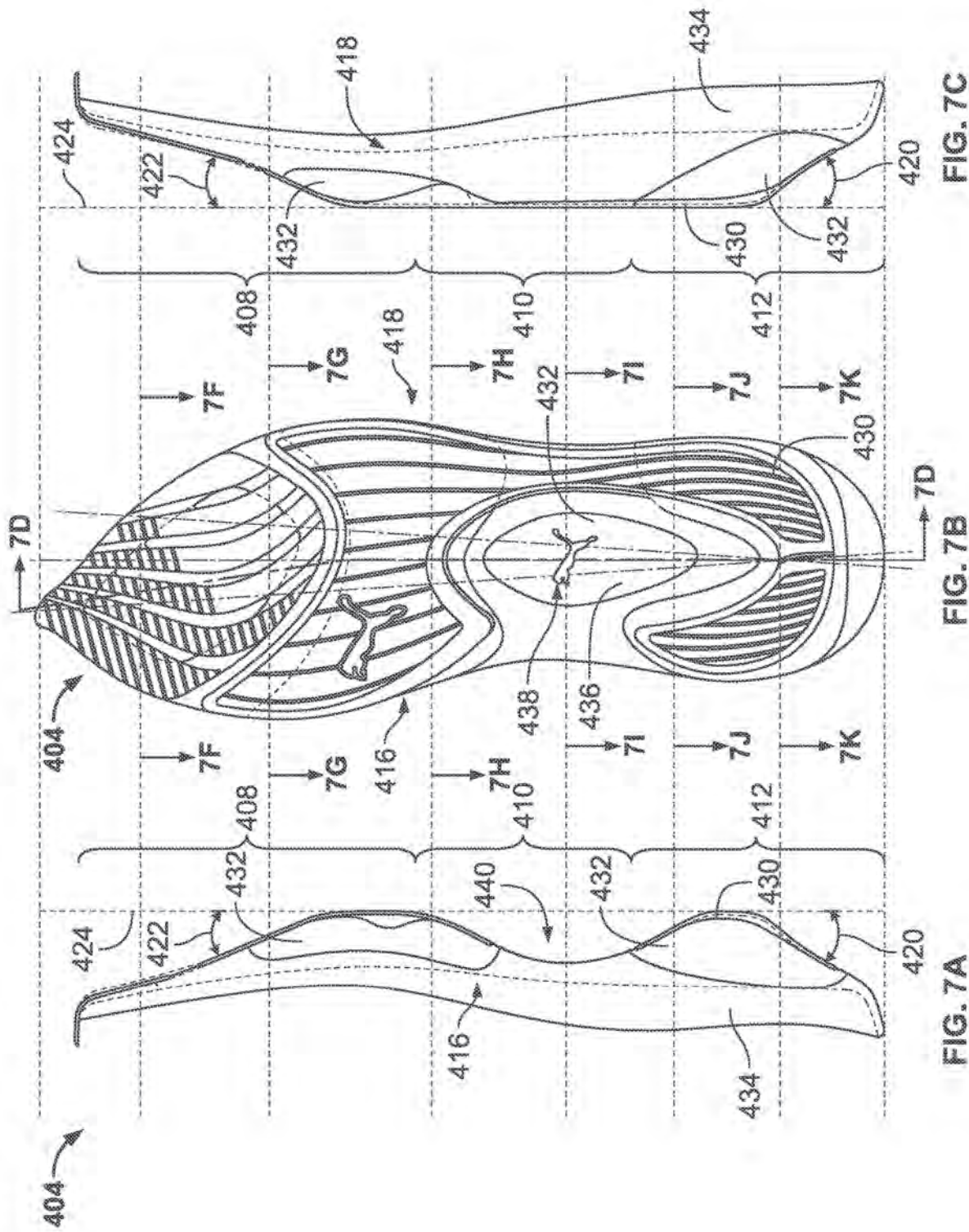

FIG. 6L



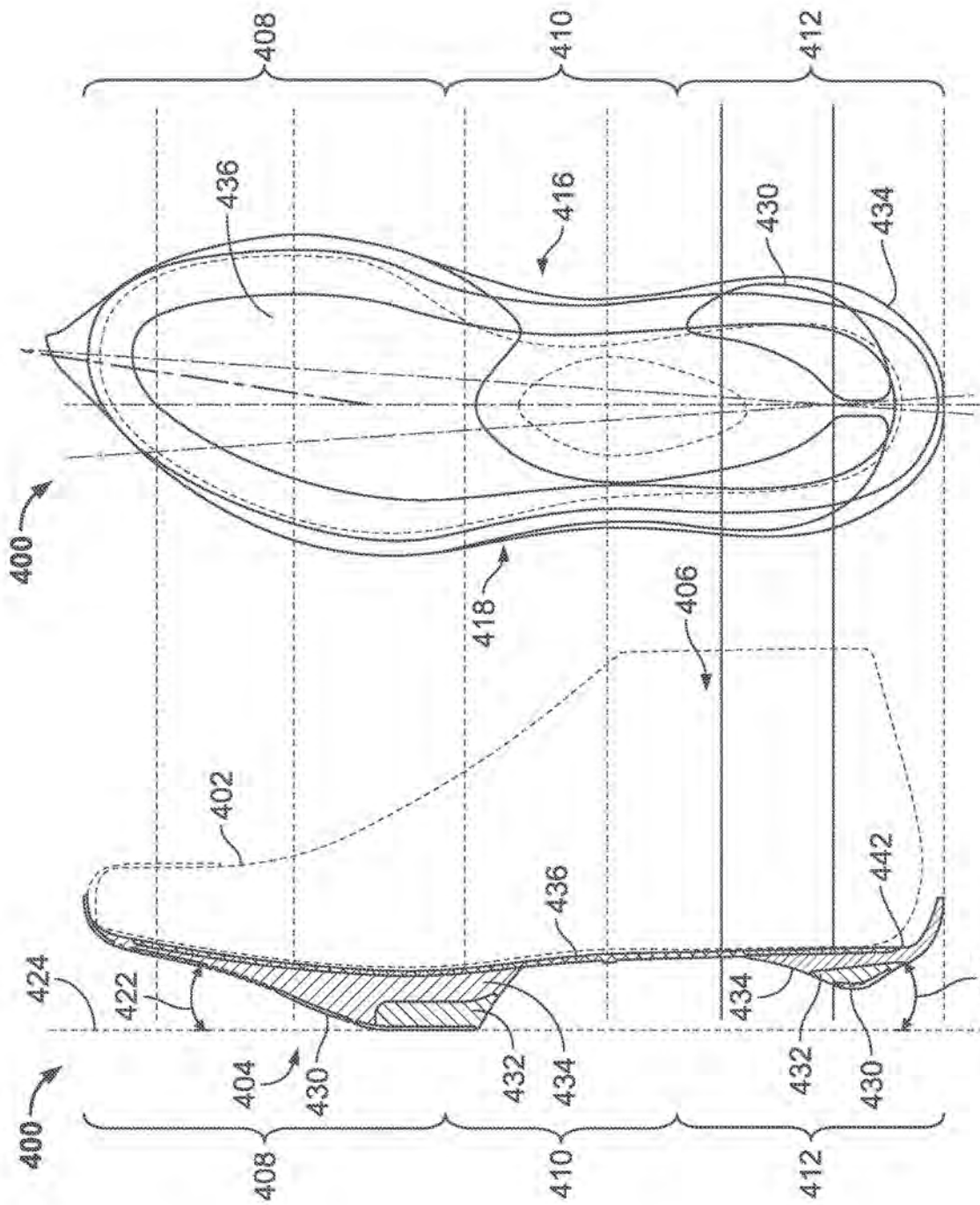

FIG. 7E

FIG. 7D

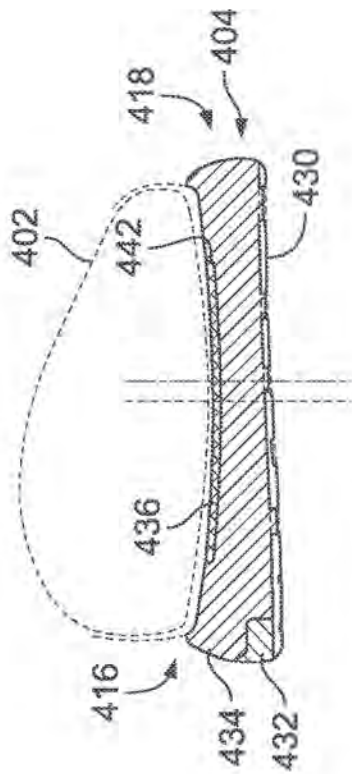

FIG. 7F

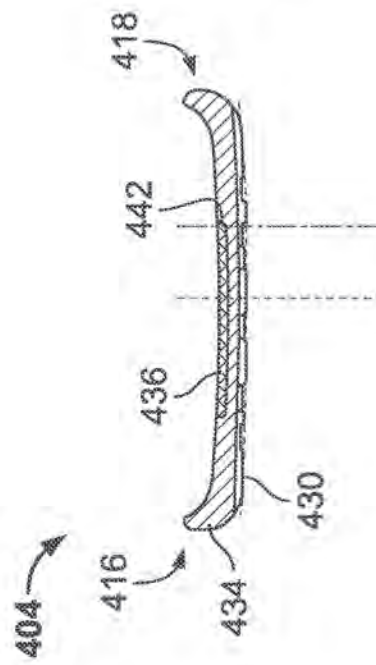

FIG. 7G

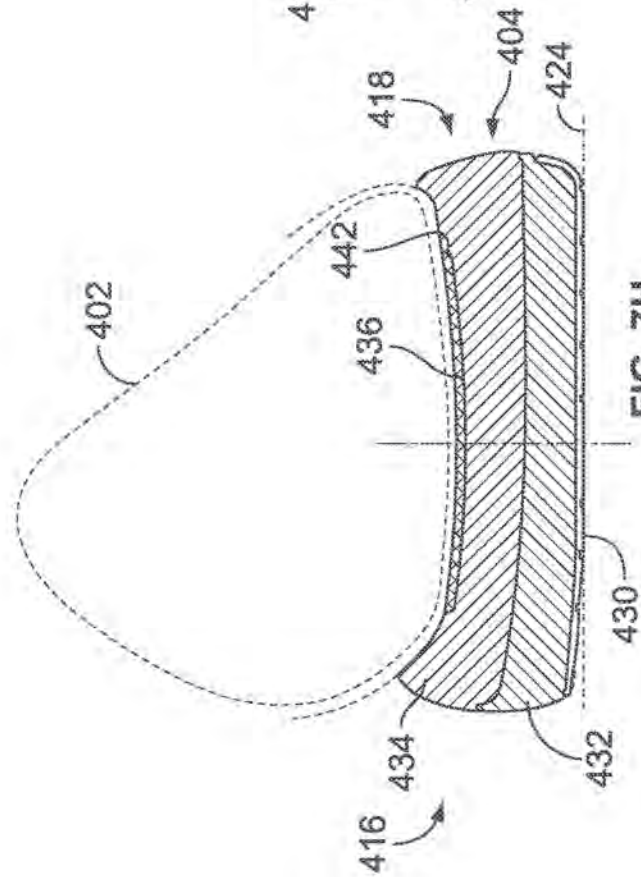

FIG. 7H

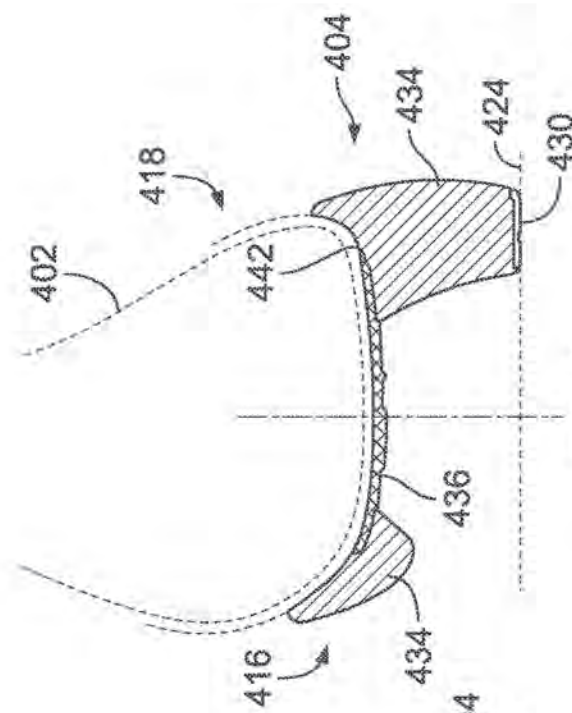

FIG. 7I

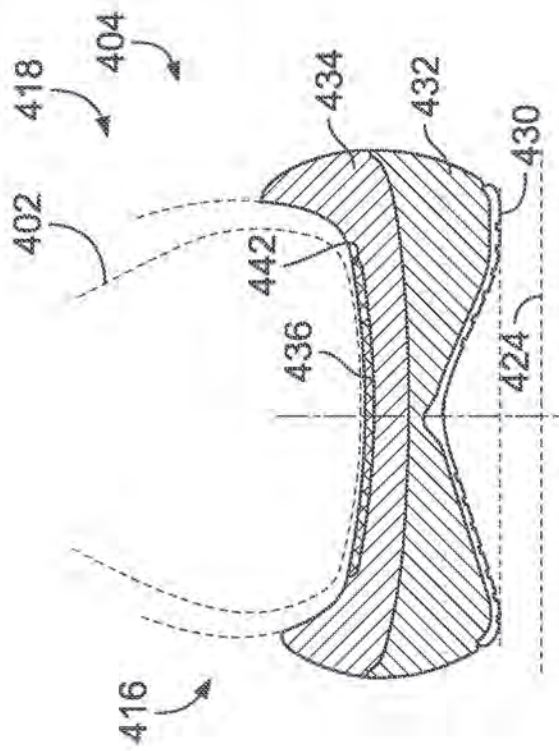

FIG. 7K

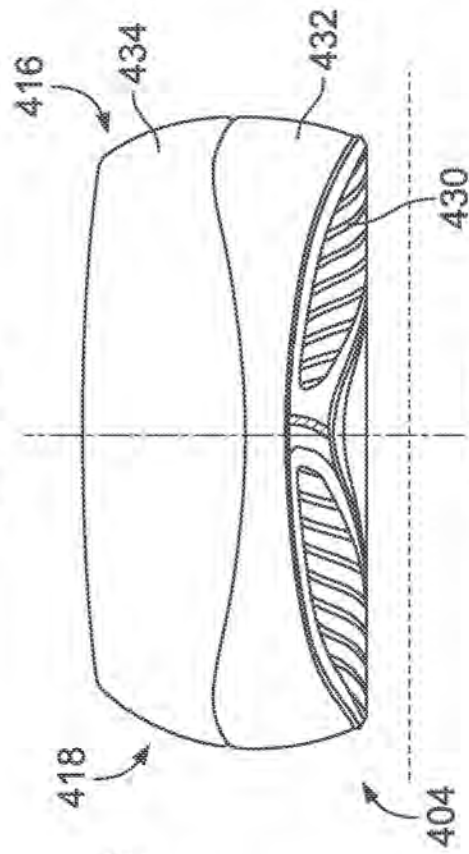

FIG. 7M

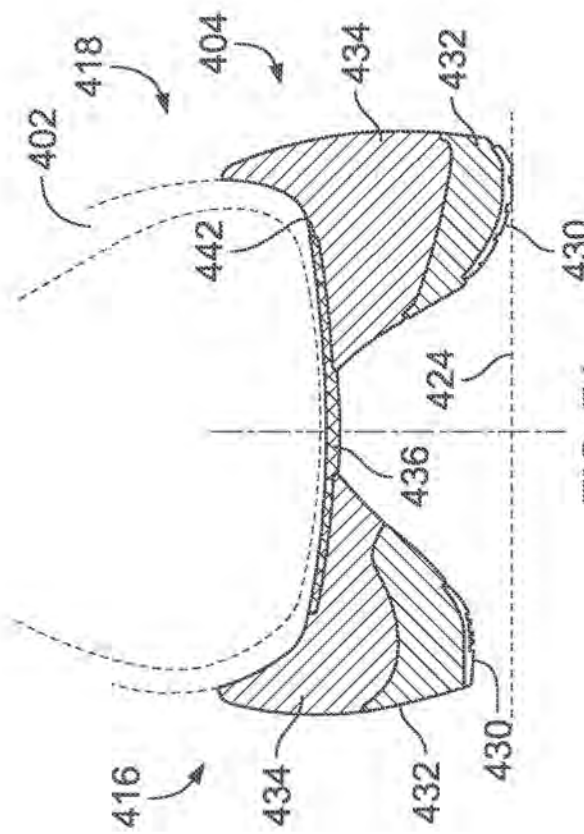

FIG. 7J

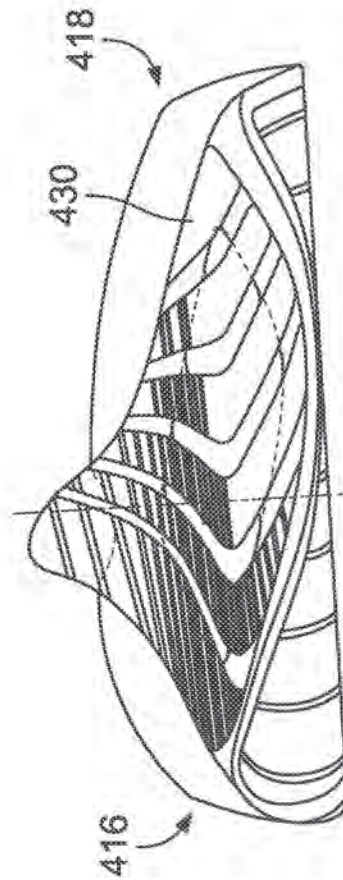
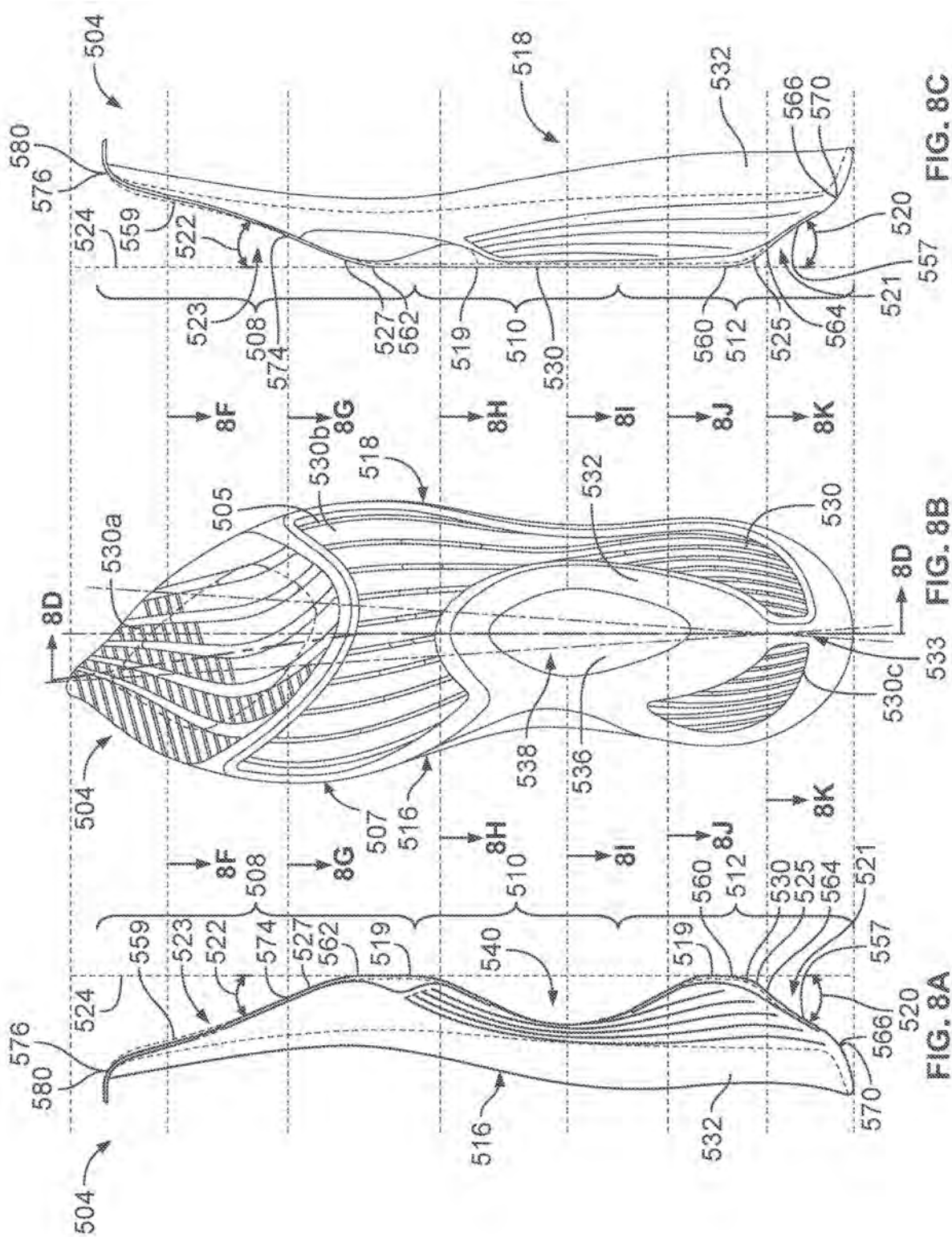

FIG. 7L



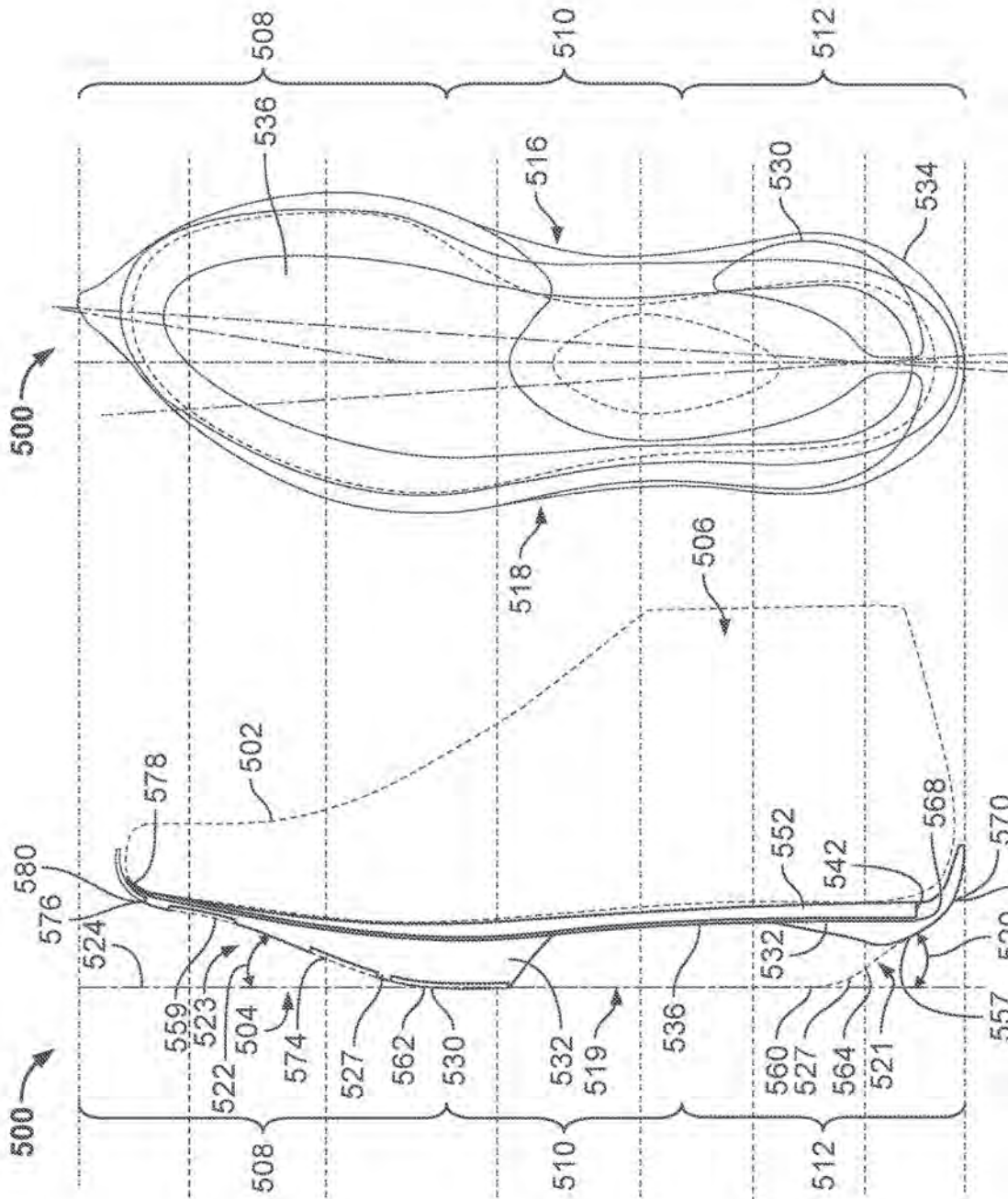

FIG. 8E

FIG. 8D

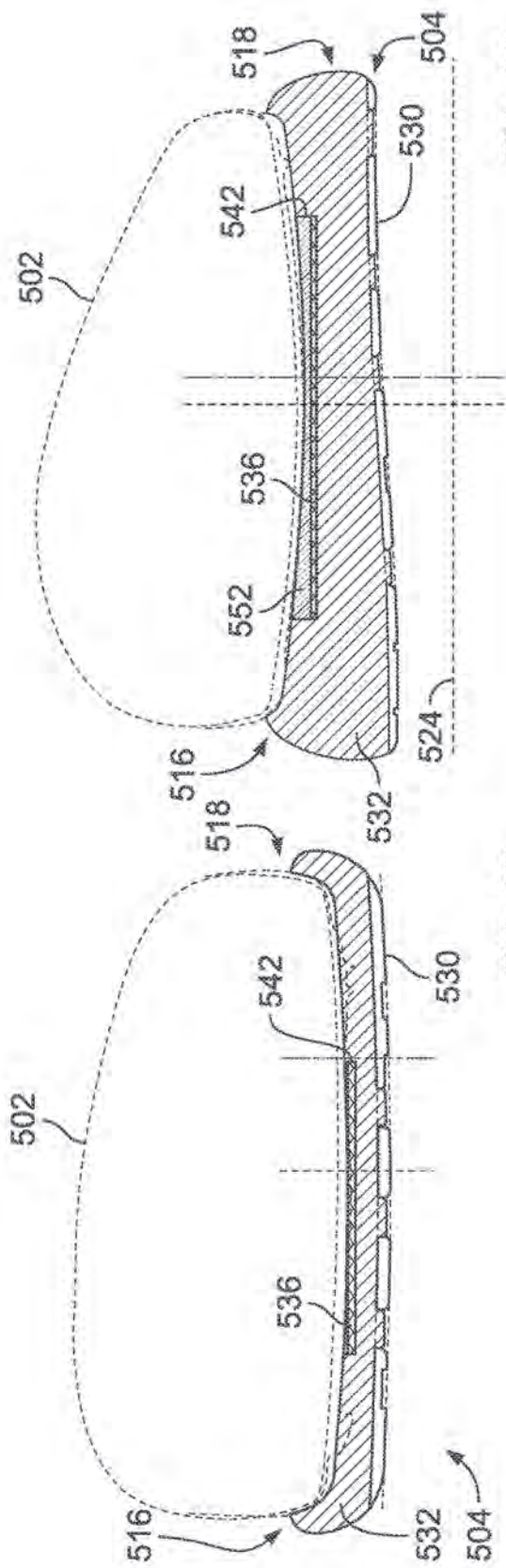

FIG. 8G

FIG. 8F

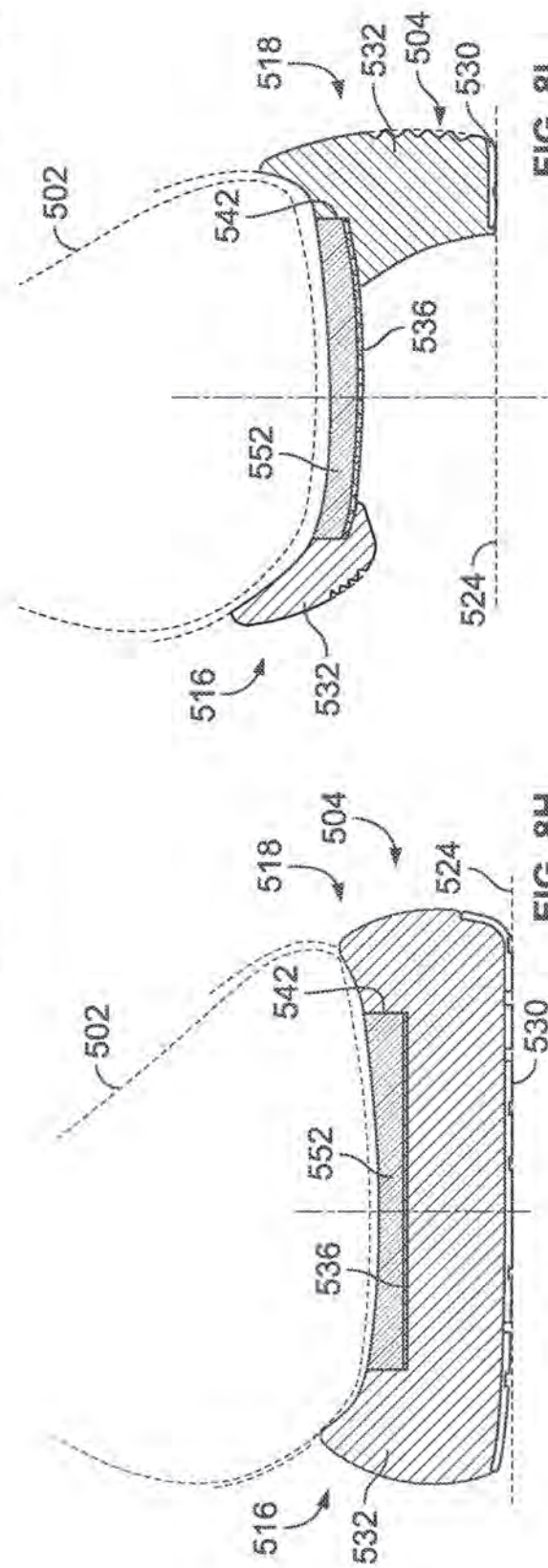

FIG. 8I

FIG. 8H

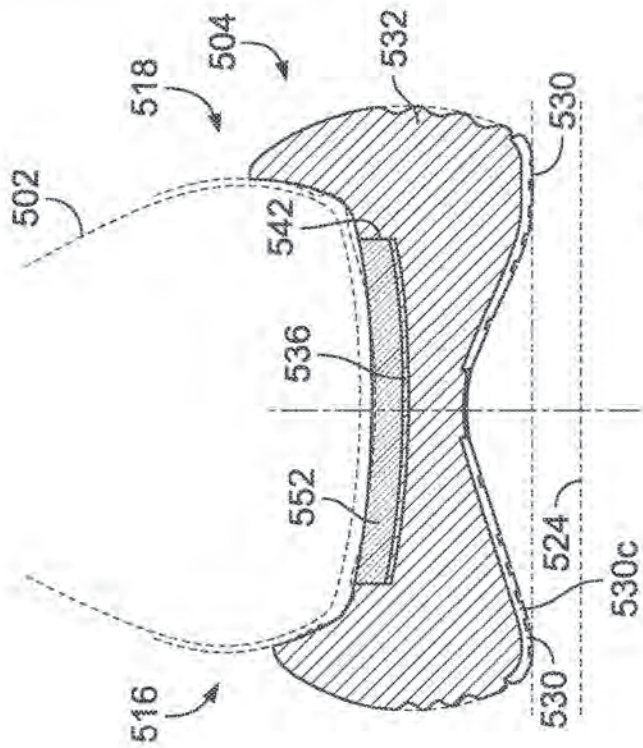

FIG. 8J

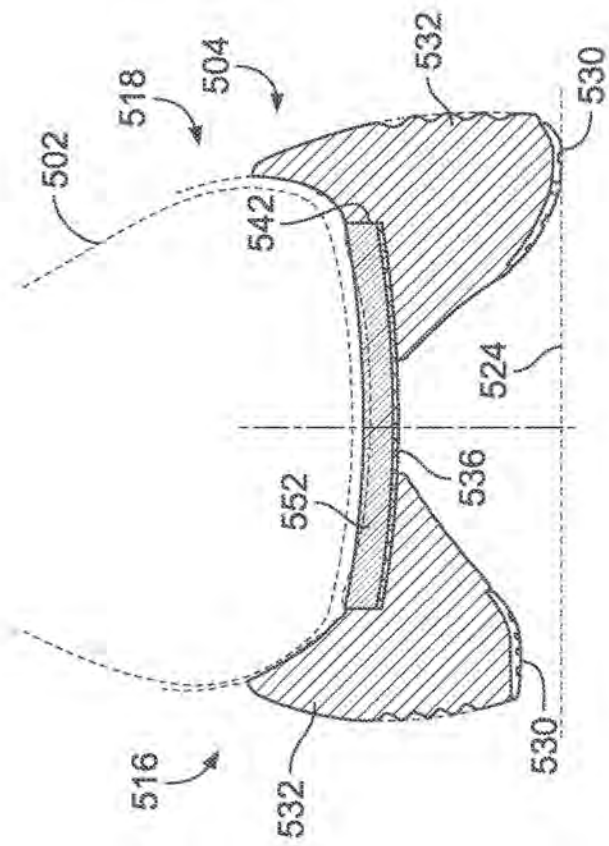

FIG. 8K

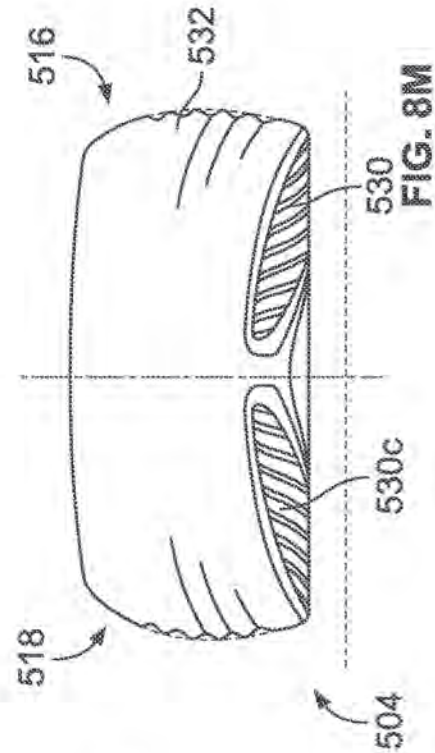

FIG. 8L

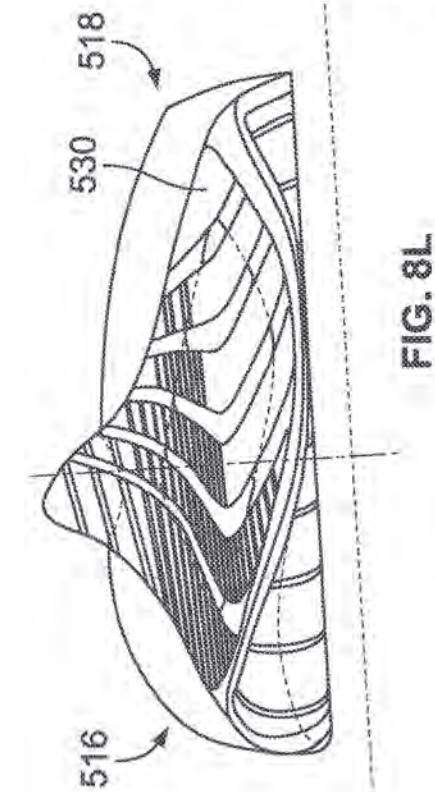
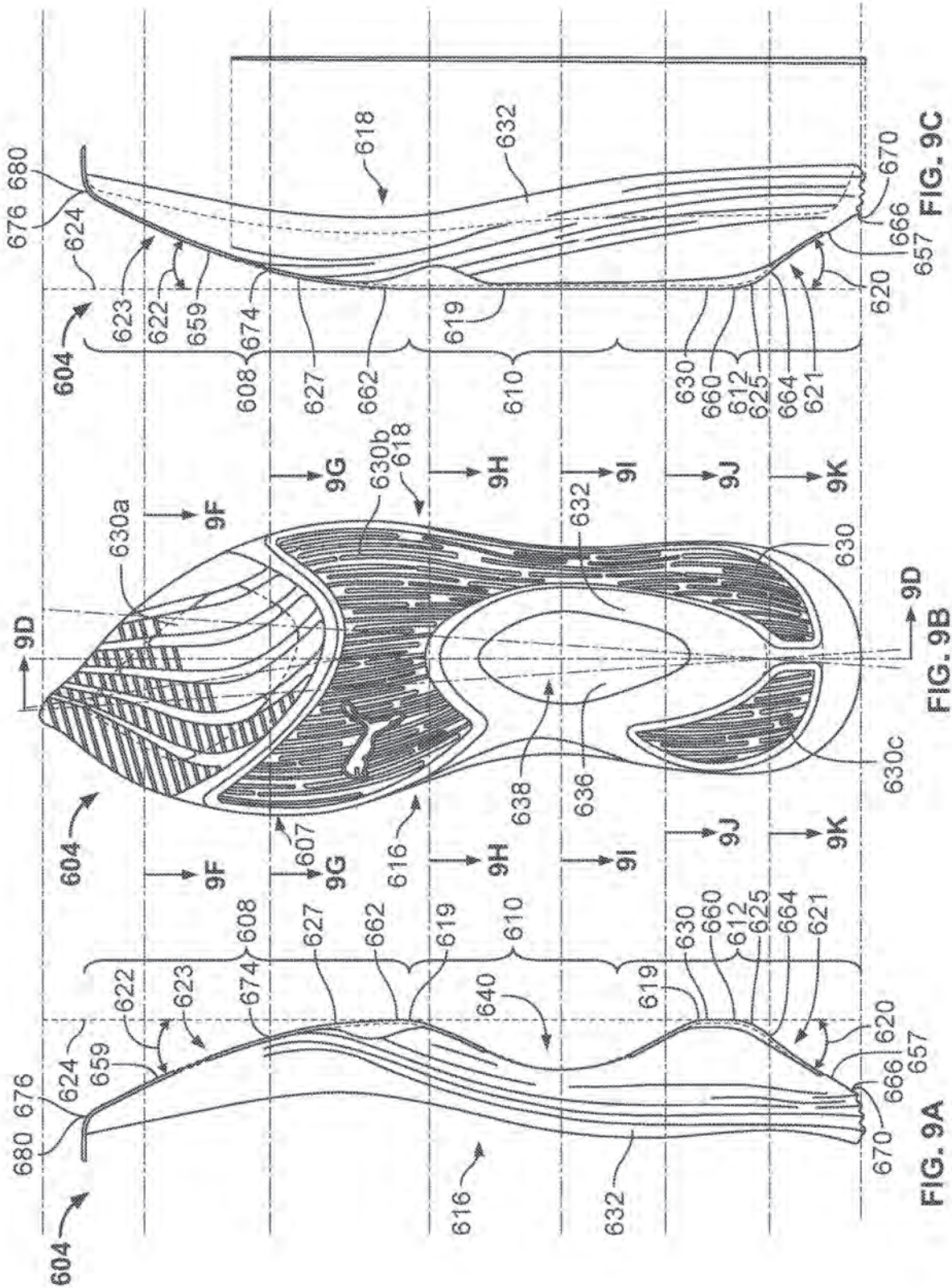

FIG. 8M



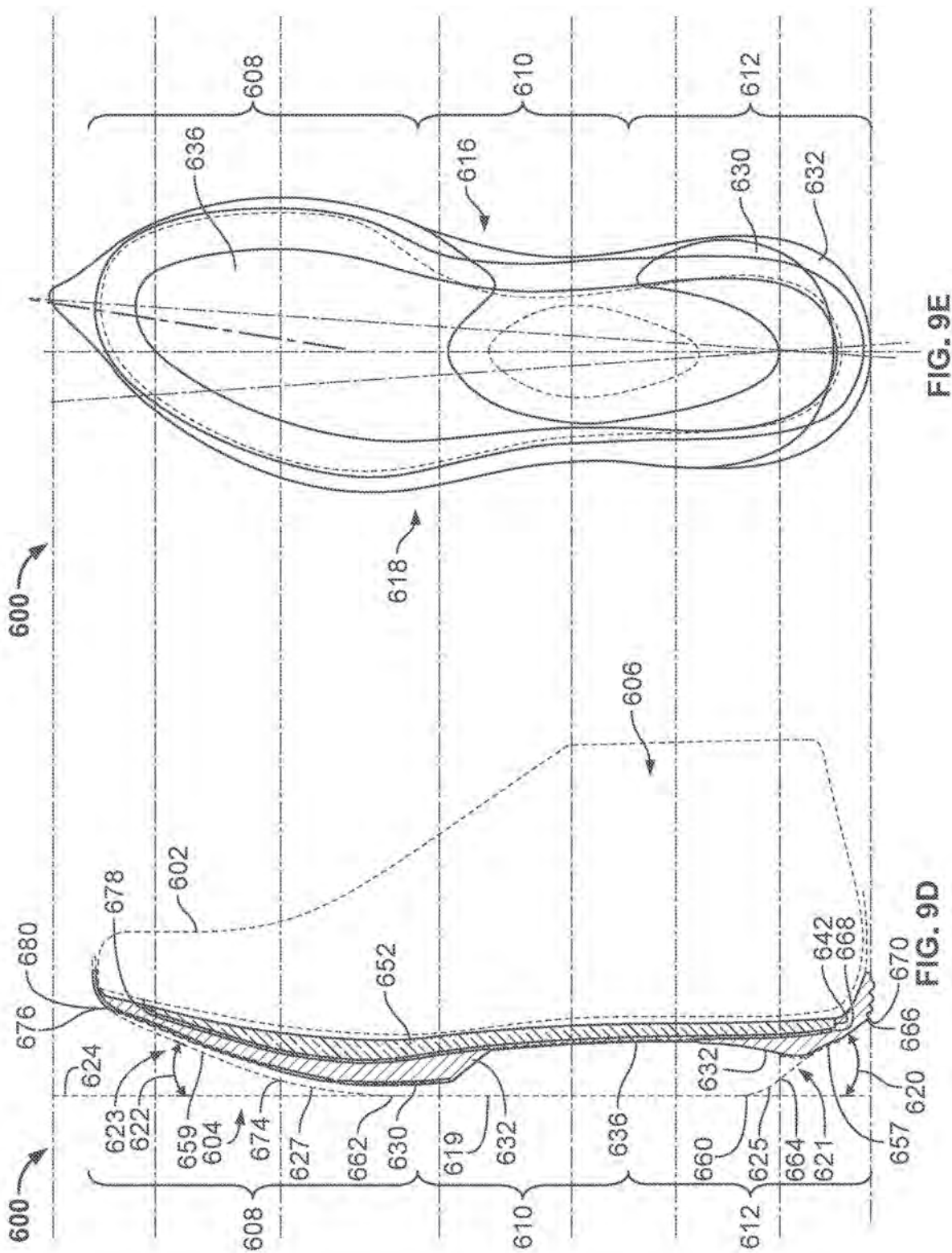

FIG. 9E

FIG. 9D

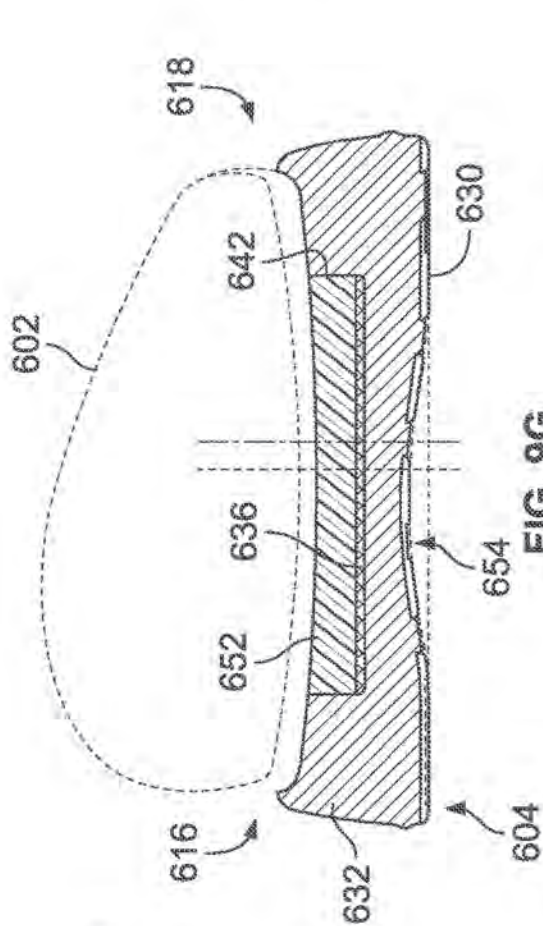

FIG. 9G

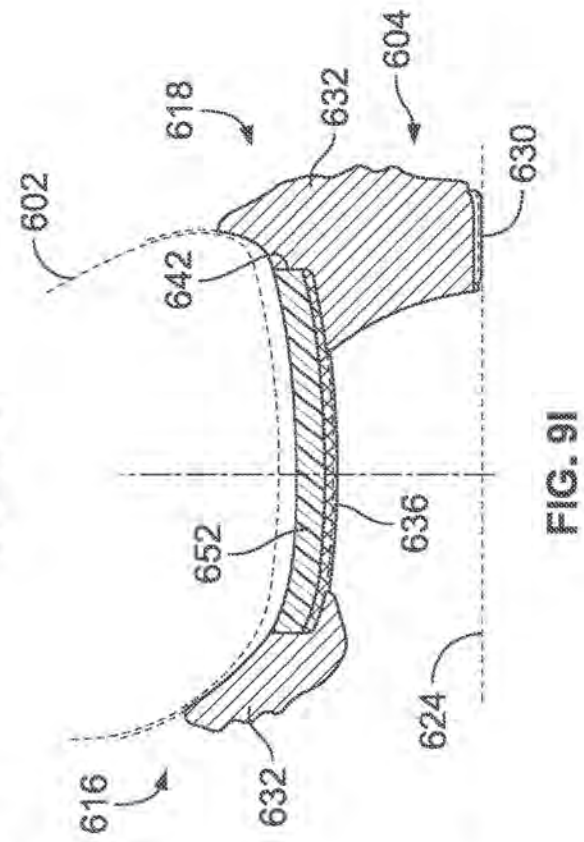

FIG. 9I

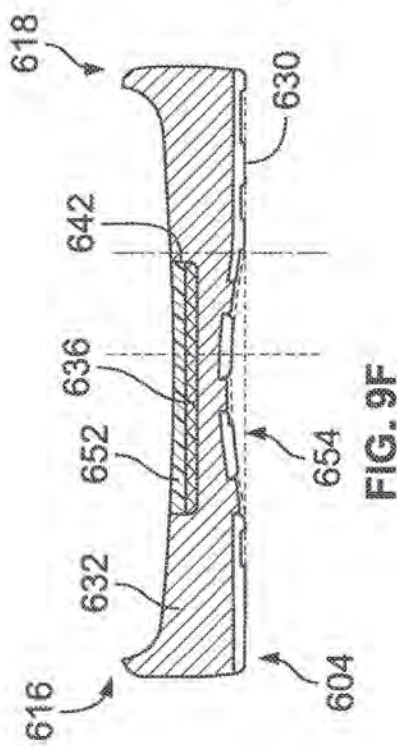

FIG. 9F

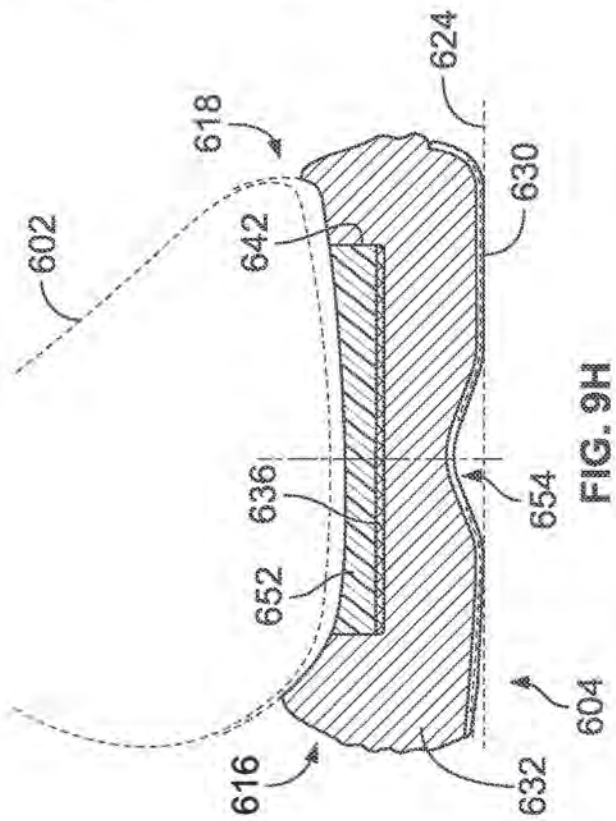

FIG. 9H

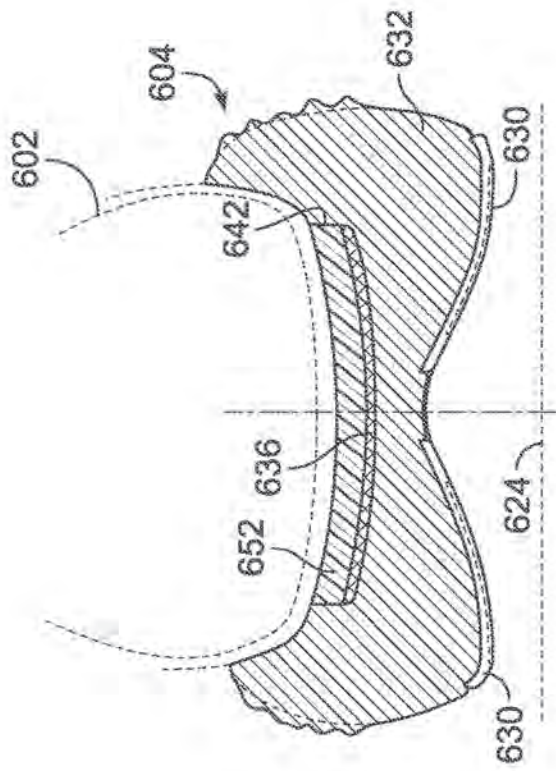

FIG. 9K

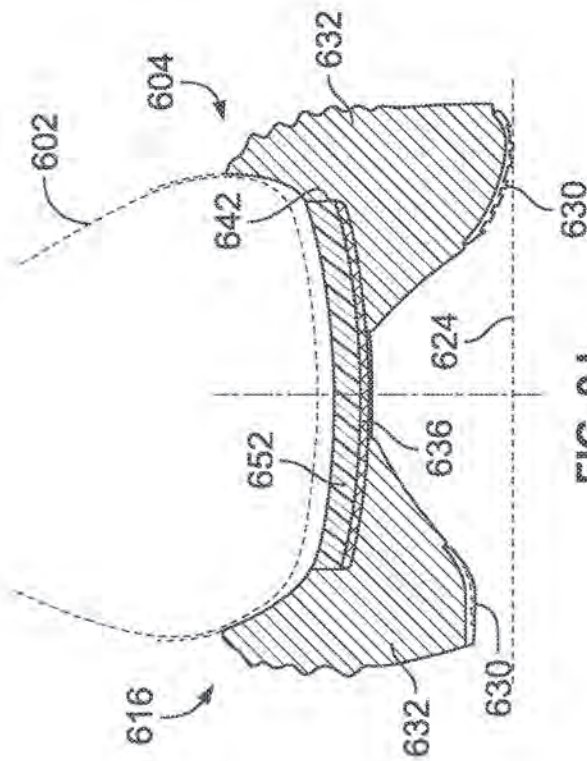

FIG. 9J

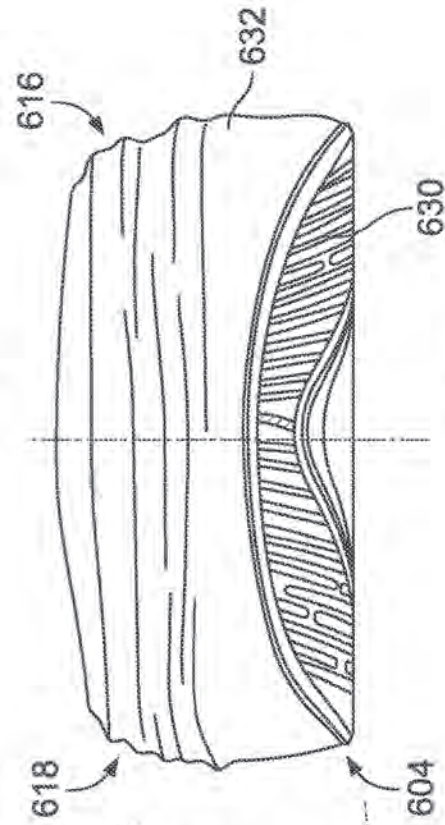

FIG. 9M

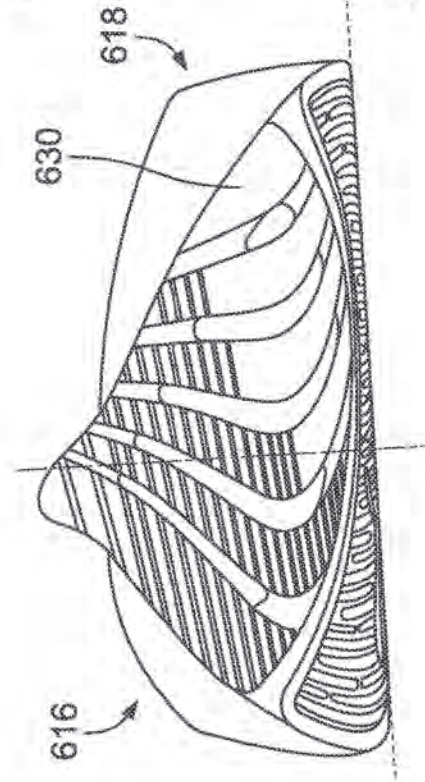
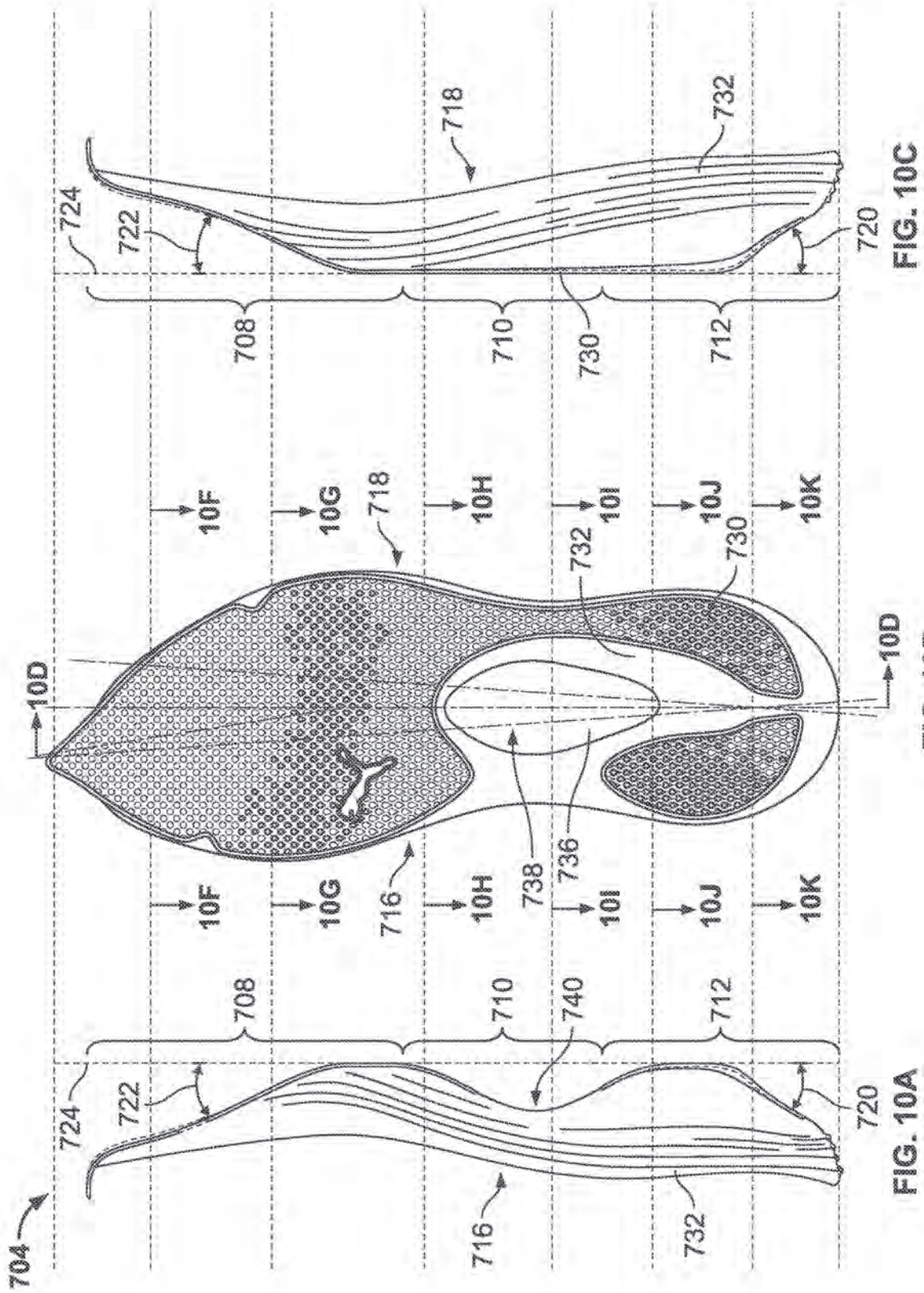

FIG. 9L



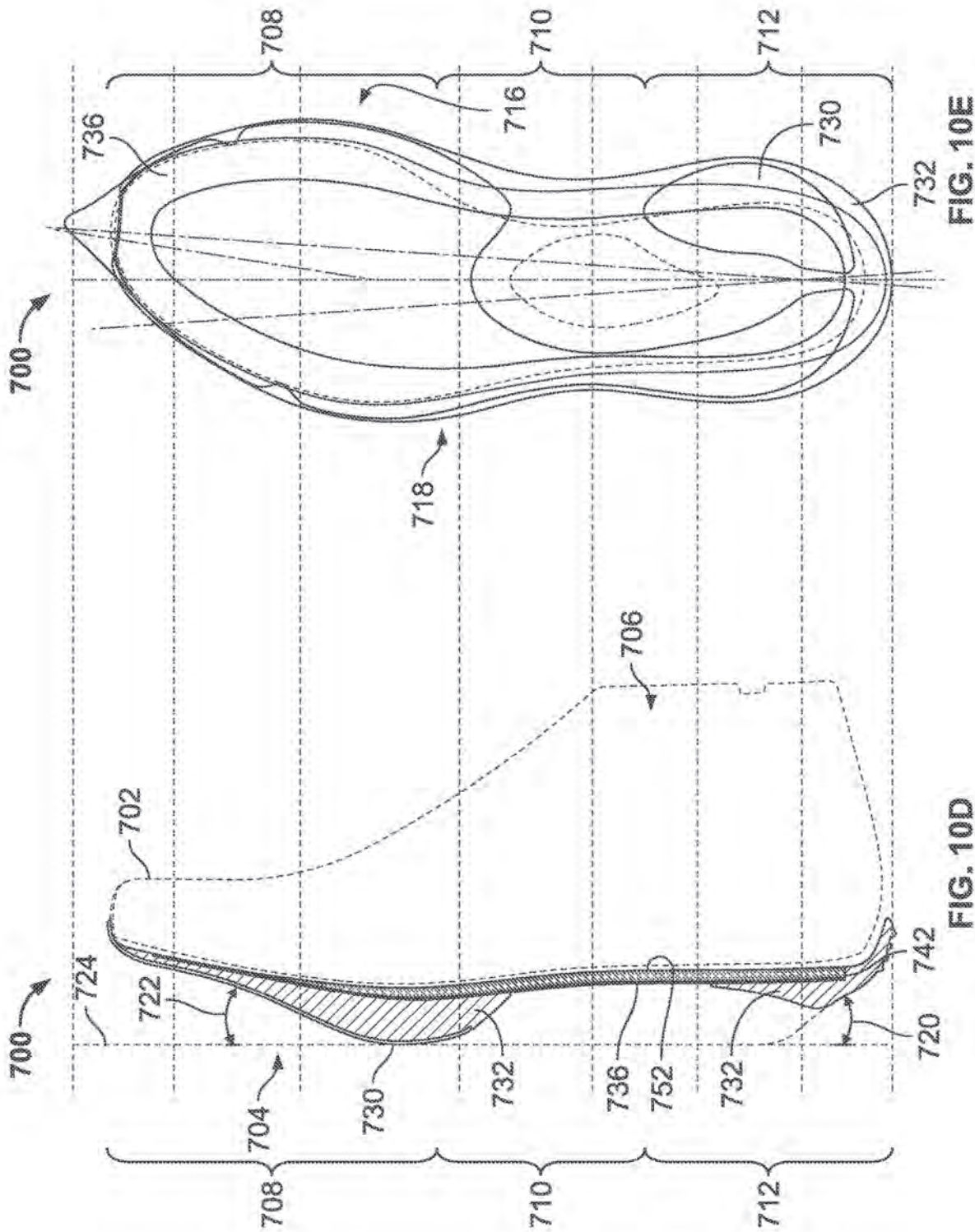

FIG. 10E

FIG. 10D

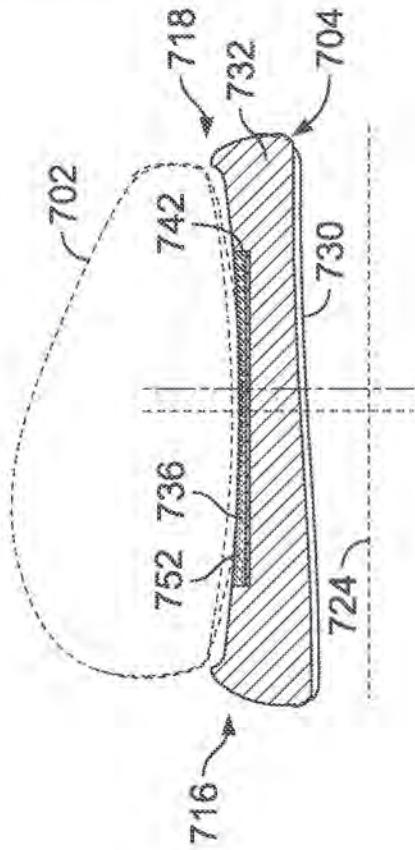

FIG. 10G

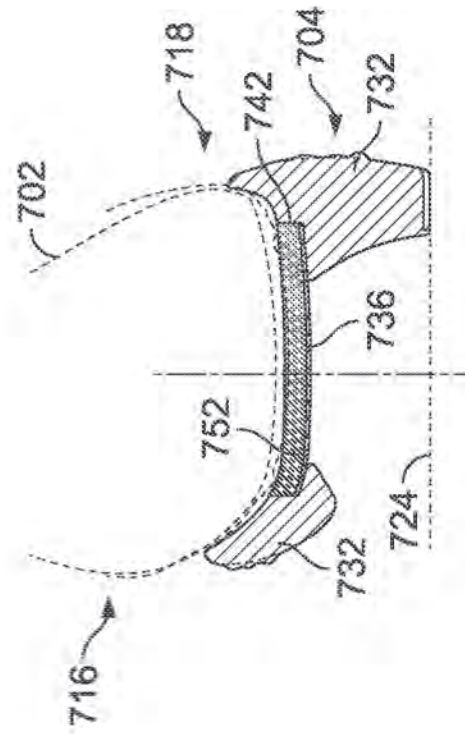

FIG. 10I

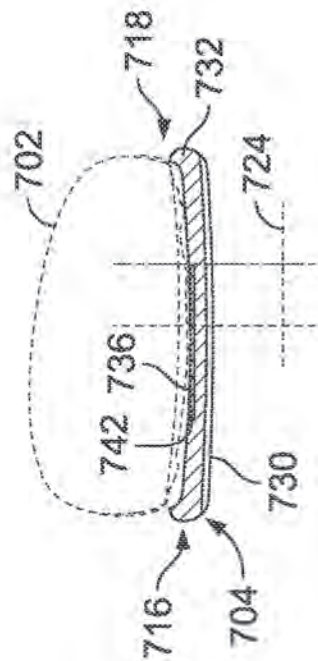

FIG. 10F

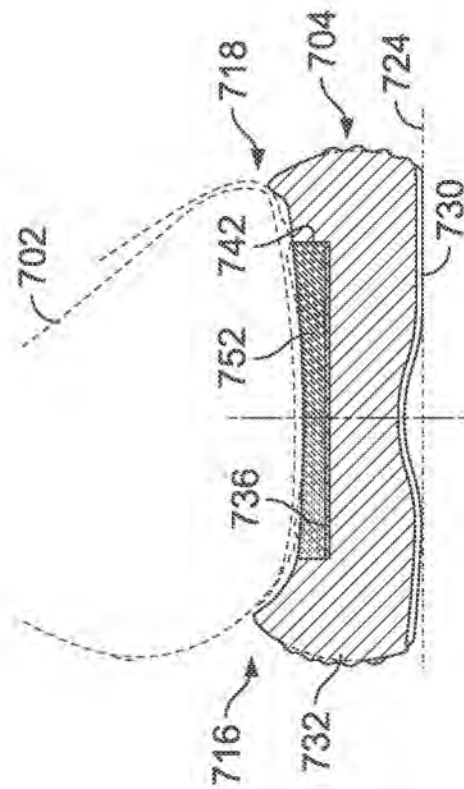

FIG. 10H

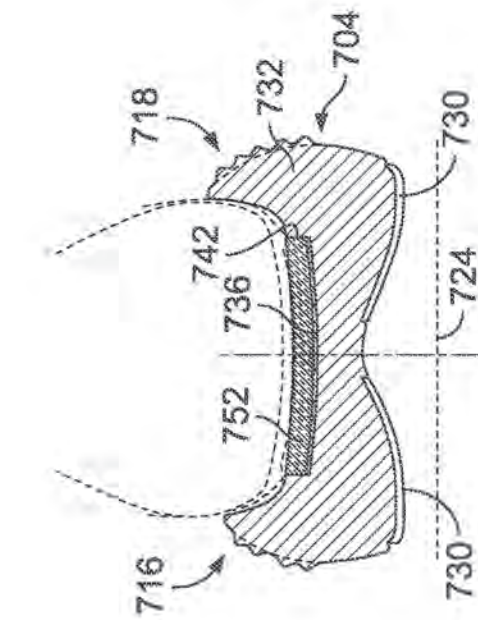

FIG. 10K

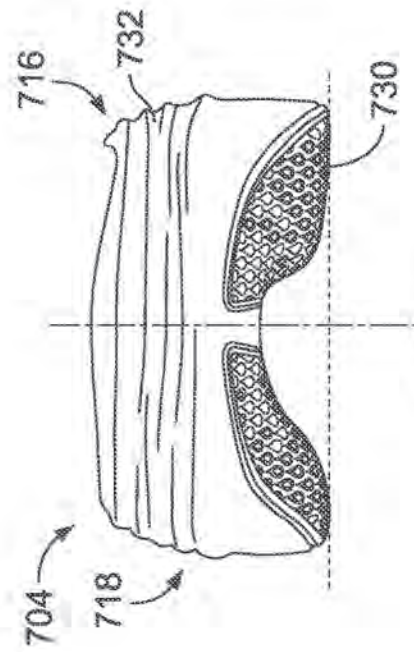

FIG. 10M

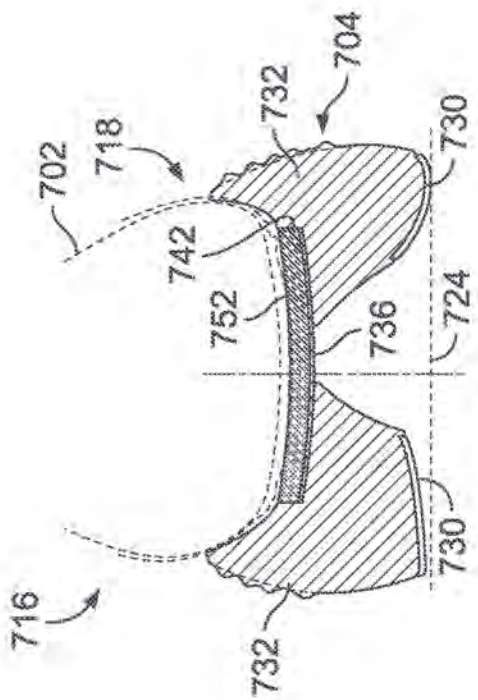

FIG. 10J

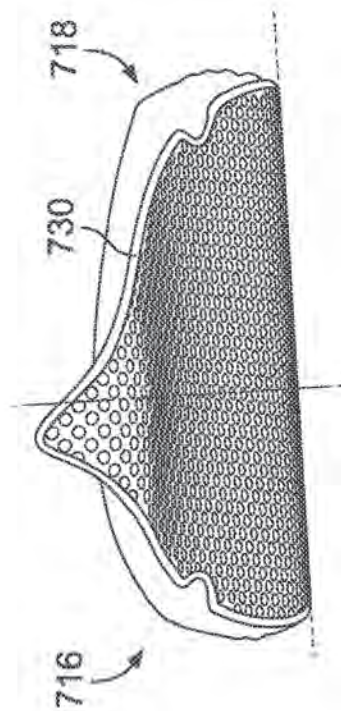

FIG. 10L

US 12,016,422 B2

1

ARTICLE OF FOOTWEAR HAVING A SOLE PLATE**CROSS REFERENCE TO RELATED APPLICATIONS**

This application is a continuation of U.S. patent application Ser. No. 17/383,954, filed Jul. 23, 2021, which claims priority to U.S. Provisional Application Ser. No. 63/055,506, filed Jul. 23, 2020, and U.S. Provisional Application Ser. No. 63/195,320, filed on Jun. 1, 2021, the contents of which are incorporated by reference herein in their entireties and are to be considered a part of this application.

REFERENCE REGARDING FEDERALLY SPONSORED RESEARCH OR DEVELOPMENT

Not applicable

SEQUENCE LISTING

Not applicable

BACKGROUND**1. Field of the Invention**

The present disclosure relates generally to an article of footwear including a sole plate.

2. Description of the Background

Many conventional shoes or other articles of footwear generally comprise an upper and a sole attached to a lower end of the upper. Conventional shoes further include an internal space, i.e., a void or cavity, which is created by interior surfaces of the upper and sole, which receives a foot of a user before securing the shoe to the foot. The sole is attached to a lower surface or boundary of the upper and is positioned between the upper and the ground. As a result, the sole typically provides stability and cushioning to the user when the shoe is being worn. In some instances, the sole may include multiple components, such as an outsole, a midsole, and an insole. The outsole may provide traction to a bottom surface of the sole, and the midsole may be attached to an inner surface of the outsole, and may provide cushioning or added stability to the sole. For example, a sole may include a particular foam material that may increase stability at one or more desired locations along the sole, or a foam material that may reduce stress or impact energy on the foot or leg when a user is running, walking, or engaged in another activity. The sole may also include additional components, such as plates, embedded with the sole to increase the overall stiffness of the sole and reduce energy loss during use.

The upper generally extends upward from the sole and defines an interior cavity that completely or partially encases a foot. In most cases, the upper extends over the instep and toe regions of the foot, and across medial and lateral sides thereof. Many articles of footwear may also include a tongue that extends across the instep region to bridge a gap between edges of medial and lateral sides of the upper, which define an opening into the cavity. The tongue may also be disposed below a lacing system and between medial and lateral sides of the upper, to allow for adjustment of shoe tightness. The tongue may further be manipulable by a user to permit entry or exit of a foot from the internal space or cavity. In addition,

2

the lacing system may allow a user to adjust certain dimensions of the upper or the sole, thereby allowing the upper to accommodate a wide variety of foot types having varying sizes and shapes.

5 The upper of many shoes may comprise a wide variety of materials, which may be utilized to form the upper and chosen for use based on one or more intended uses of the shoe. The upper may also include portions comprising varying materials specific to a particular area of the upper. 10 For example, added stability may be desirable at a front of the upper or adjacent a heel region so as to provide a higher degree of resistance or rigidity. In contrast, other portions of a shoe may include a soft woven textile to provide an area with stretch-resistance, flexibility, air-permeability, or moisture-wicking properties. 15

Further, many conventional shoes or other articles of footwear, when used as a running shoe, promote an impact force at the heel region of the wearer. In particular, the impact force can be transferred from a heel of a foot, to an ankle, to a shin, to a knee, and into the hips and back of the wearer. Such impact can lead to unwanted stress on limbs when there is an instant that leg muscles are improperly tensioned and the limbs and bones are left to absorb the impact forces. The excess stress on limbs and bones can 25 have long-term, adverse effects, such as, for example, arthritis.

However, in many cases, articles of footwear could benefit from having uppers with an increased comfort and better fit are desired, along with soles having improved cushioning systems or structural characteristics such as a sole plate to add rigidity or spring-like properties. Additionally, articles of footwear could benefit from having a ground-engaging profile that promotes constant muscle tension to absorb and distribute impact forces are desired. 30

SUMMARY

An article of footwear, as described herein, may have various configurations. The article of footwear may have an upper and a sole structure connected to the upper.

According to one aspect, an article of footwear can include a sole structure and an upper. The sole structure can include an outsole having a ground engaging surface and a midsole member disposed between the outsole and the upper. The midsole can be a supercritical foam and can include a pocket that can extend from a heel region to a forefoot region. A sole plate can be disposed within the pocket and can extend from the heel region into the forefoot region. In the heel region, the sole structure can be shaped to define an entry region that can be configured to increase contact at the ground engaging surface during a heel strike. The entry region can define an angled portion that is angled at an entry angle relative to a flat ground surface.

In some embodiments, the sole structure can be shaped in the forefoot region to define an exit region that curves to angle away from the flat ground surface. The exit region can form a rocking member with a fulcrum proximate a widest portion of the sole structure. The rocking member can form a propulsion lever with the sole plate, which can be configured to propel a user forward during toe off. 60

In some embodiments, the sole structure can further include a cushioning layer that can be disposed between the midsole member and the upper. The cushioning layer can be positioned on top of the sole plate so that the sole plate is positioned between the midsole member and the cushioning layer. In some cases, the sole plate can be a carbon fiber plate that can be similarly shaped to and proportionally smaller 65

US 12,016,422 B2

3

than the midsole member in at least one of the forefoot region, a midfoot region, or the heel region of the sole structure.

In some embodiments, the midsole member can define a longitudinal channel that can extend from a heel end of the sole structure and into a midfoot region. The outsole can include a first outsole member and a second outsole member that are separated from one another by the longitudinal channel so that the ground engaging surface may not be continuous across the heel region between a lateral side and medial side of the sole structure.

In some embodiments, the outsole can include a first outsole member in the forefoot region and a second outsole member in the heel region. The ground engaging surface may not be continuous along a medial side of a midfoot region of the sole structure.

According to another aspect, an article of footwear can include a sole structure and an upper. The sole structure can include an outsole that can define a ground engaging surface and a midsole that can extend between the outsole and the upper. The midsole can include a first midsole member and a second midsole member, and at least one of the first midsole member or the second midsole member is a supercritical foam. The first midsole member can be coupled to the outsole and can extend from a forefoot region to a heel region of the sole structure. The first midsole member can define an entry region at a heel end in which the first midsole member is angled away from a ground surface by a first angle that is configured to increase contact at the ground engaging surface during a heel strike. The second midsole member can be coupled to the upper and can be positioned between the first midsole member and the upper. The second midsole member can extend from the heel region to the forefoot region. A sole plate can be positioned within the midsole between the first midsole member and the second midsole member.

In some embodiments, the outsole can extend at least partially into the entry region.

In some embodiments, the first midsole member can further define an exit region in the forefoot region. In the exit region, the first midsole member can curve away from the ground surface from approximately a widest portion of the sole structure to a toe end of the sole structure. In some cases, the first midsole member can define a substantially flat region between the entry region and the exit region. The first midsole member can define a rocking member between the substantially flat region and the exit region, which can create a fulcrum for the sole plate to help propel a user forward during toe off. The fulcrum can be positioned to be proximate metatarsal bones of a user.

In some embodiments, the first midsole member can define a pocket and at least one of the sole plate or the second midsole member can be disposed at least partially within the pocket. In some cases, the sole plate can be comprised of carbon fibers and extend from the heel region to the forefoot region.

According to yet another aspect, an article of footwear can include a sole structure and an upper. The sole structure can include a first midsole member and a second midsole member, and at least one of the first midsole member or the second midsole member can be a supercritical foam. The first midsole member can have a bottom surface opposite a top surface and can extend from a forefoot region to a heel region of the sole structure. The first midsole member can define an upwardly curved entry region along the bottom surface in the heel region, an upwardly curved exit region along the bottom surface in the forefoot region, and a

4

substantially flat region extending along the bottom surface between the entry region and the exit region. At least a portion of the entry region can be angled relative to the substantially flat region to define an entry angle. The second midsole member can be positioned between the first midsole member and the upper, and can extend from the heel region to the forefoot region. A sole plate can be positioned between the first midsole member and the second midsole member. The first midsole member can define a rocking member between the substantially flat region and the exit region. The rocking member can create a fulcrum for the sole plate to help propel a user forward during toe off.

In some embodiments, the sole plate can define a first region with a first stiffness and a second region with a second stiffness. The second stiffness can be greater than the first stiffness.

In some embodiments, the sole structure can further include an outsole that can be coupled to the bottom surface of the first midsole member. The outsole can define a ground engaging surface of the sole structure and can include a first outsole portion positioned in the forefoot region and a second outsole portion positioned in the heel region. The first outsole portion and the second outsole portion can be spaced from one another so that the ground engaging surface is not continuous between the first outsole portion and the second outsole portion.

In some embodiments, the exit region can curve upwardly from approximately a widest portion of the sole structure to a toe end of the sole structure.

BRIEF DESCRIPTION OF THE DRAWINGS

FIG. 1 is a medial side view of an article of footwear configured as a left shoe that includes an upper and a sole structure according to an embodiment of the disclosure;

FIG. 2 is a lateral side view of the shoe of FIG. 1;

FIG. 3 is a bottom view of the shoe of FIG. 1;

FIG. 4 is a top plan view of the article of footwear of FIG. 1, with an upper removed and a user's skeletal foot structure overlaid thereon;

FIG. 5A is a medial view of a sole structure of an article of footwear that includes a sole plate according to an embodiment of the disclosure;

FIG. 5B is a bottom view of the sole structure of FIG. 5A; FIG. 5C is a lateral side view of the sole structure of FIG. 5A;

FIG. 5D is a cross-sectional view of the sole structure of FIG. 5A taken along line 5D-5D of FIG. 5B;

FIG. 5E is a top view of the sole structure of FIG. 5A;

FIG. 5F is a cross-sectional view of the sole structure of FIG. 5A taken along line 5F-5F of FIG. 5B;

FIG. 5G is a cross-sectional view of the sole structure of FIG. 5A taken along the line 5G-5G of FIG. 5B;

FIG. 5H is a cross-sectional view of the sole structure of FIG. 5A taken along the line 5H-5H of FIG. 5B;

FIG. 5I is a cross sectional view of the sole structure of FIG. 5A taken along the line 5I-5I of FIG. 5B;

FIG. 5J is a cross-sectional view of the sole structure of FIG. 5A taken along the line 5J-5J of FIG. 5B;

FIG. 5K is a cross-sectional view of the sole structure of FIG. 5A taken along the line 5K-5K of FIG. 5B;

FIG. 5L is a toe view of the sole structure of FIG. 5A;

FIG. 5M is a heel view of the sole structure of FIG. 5A;

FIG. 6A is a medial side view of a sole structure of an article of footwear that includes a sole plate and a foam layer according to an embodiment of the disclosure;

FIG. 6B is a bottom view of the sole structure of FIG. 6A;

US 12,016,422 B2

5

FIG. 6C is a lateral side view of the sole structure of FIG. 6A;

FIG. 6D is a cross-sectional view of the sole structure of FIG. 6A taken along line 6D-6D of FIG. 6B;

FIG. 6E is a top view of the sole structure of FIG. 6A;

FIG. 6F is a cross-sectional view of the sole structure of FIG. 6A taken along line 6F-6F of FIG. 6B;

FIG. 6G is a cross-sectional view of the sole structure of FIG. 6A taken along the line 6G-6G of FIG. 6B;

FIG. 6H is a cross-sectional view of the sole structure of FIG. 6A taken along the line 6H-6H of FIG. 6B;

FIG. 6I is a cross sectional view of the sole structure of FIG. 6A taken along the line 6I-6I of FIG. 6B;

FIG. 6J is a cross-sectional view of the sole structure of FIG. 6A taken along the line 6J-6J of FIG. 6B;

FIG. 6K is a cross-sectional view of the sole structure of FIG. 6A taken along the line 6K-6K of FIG. 6B;

FIG. 6L is a toe view of the sole structure of FIG. 6A;

FIG. 6M is a heel view of the sole structure of FIG. 6A;

FIG. 7A is a medial side view of a sole structure of an article of footwear that includes a sole plate according to an embodiment of the disclosure;

FIG. 7B is a bottom view of the sole structure of FIG. 7A;

FIG. 7C is a lateral side view of the sole structure of FIG. 7A;

FIG. 7D is a cross-sectional view of the sole structure of FIG. 7A taken along line 7D-7D of FIG. 7B;

FIG. 7E is a top view of the sole structure of FIG. 7A;

FIG. 7F is a cross-sectional view of the sole structure of FIG. 7A taken along line 7F-7F of FIG. 7B;

FIG. 7G is a cross-sectional view of the sole structure of FIG. 7A taken along the line 7G-7G of FIG. 7B;

FIG. 7H is a cross-sectional view of the sole structure of FIG. 7A taken along the line 7H-7H of FIG. 7B;

FIG. 7I is a cross sectional view of the sole structure of FIG. 7A taken along the line 7I-7I of FIG. 7B;

FIG. 7J is a cross-sectional view of the sole structure of FIG. 7A taken along the line 7J-7J of FIG. 7B;

FIG. 7K is a cross-sectional view of the sole structure of FIG. 7A taken along the line 7K-7K of FIG. 7B;

FIG. 7L is a toe view of the sole structure of FIG. 7A;

FIG. 7M is a heel view of the sole structure of FIG. 7A;

FIG. 8A is a medial side view of a sole structure of an article of footwear that includes a sole plate and a foam layer according to an embodiment of the disclosure;

FIG. 8B is a bottom view of the sole structure of FIG. 8A;

FIG. 8C is a lateral side view of the sole structure of FIG. 8A;

FIG. 8D is a cross-sectional view of the sole structure of FIG. 8A taken along line 8D-8D of FIG. 8B;

FIG. 8E is a top view of the sole structure of FIG. 8A;

FIG. 8F is a cross-sectional view of the sole structure of FIG. 8A taken along line 8F-8F of FIG. 8B;

FIG. 8G is a cross-sectional view of the sole structure of FIG. 8A taken along the line 8G-8G of FIG. 8B;

FIG. 8H is a cross-sectional view of the sole structure of FIG. 8A taken along the line 8H-8H of FIG. 8B;

FIG. 8I is a cross sectional view of the sole structure of FIG. 8A taken along the line 8I-8I of FIG. 8B;

FIG. 8J is a cross-sectional view of the sole structure of FIG. 8A taken along the line 8J-8J of FIG. 8B;

FIG. 8K is a cross-sectional view of the sole structure of FIG. 8A taken along the line 8K-8K of FIG. 8B;

FIG. 8L is a toe view of the sole structure of FIG. 8A;

FIG. 8M is a heel view of the sole structure of FIG. 8A;

6

FIG. 9A is a medial side view of a sole structure of an article of footwear that includes a sole plate and a foam layer according to an embodiment of the disclosure;

FIG. 9B is a bottom view of the sole structure of FIG. 9A;

FIG. 9C is a lateral side view of the sole structure of FIG. 9A;

FIG. 9D is a cross-sectional view of the sole structure of FIG. 9A taken along line 9D-9D of FIG. 9B;

FIG. 9E is a top view of the sole structure of FIG. 9A;

FIG. 9F is a cross-sectional view of the sole structure of FIG. 9A taken along line 9F-9F of FIG. 9B;

FIG. 9G is a cross-sectional view of the sole structure of FIG. 9A taken along the line 9G-9G of FIG. 9B;

FIG. 9H is a cross-sectional view of the sole structure of FIG. 9A taken along the line 9H-9H of FIG. 9B;

FIG. 9I is a cross sectional view of the sole structure of FIG. 9A taken along the line 9I-9I of FIG. 9B;

FIG. 9J is a cross-sectional view of the sole structure of FIG. 9A taken along the line 9J-9J of FIG. 9B;

FIG. 9K is a cross-sectional view of the sole structure of FIG. 9A taken along the line 9K-9K of FIG. 9B;

FIG. 9L is a toe view of the sole structure of FIG. 9A;

FIG. 9M is a heel view of the sole structure of FIG. 9A;

FIG. 10A is a medial side view of a sole structure of an article of footwear that includes a sole plate and a foam layer according to an embodiment of the disclosure;

FIG. 10B is a bottom view of the sole structure of FIG. 10A;

FIG. 10C is a lateral side view of the sole structure of FIG. 10A;

FIG. 10D is a cross-sectional view of the sole structure of FIG. 10A taken along line 10D-10D of FIG. 10B;

FIG. 10E is a top view of the sole structure of FIG. 10A;

FIG. 10F is a cross-sectional view of the sole structure of FIG. 10A taken along line 10F-10F of FIG. 10B;

FIG. 10G is a cross-sectional view of the sole structure of FIG. 10A taken along the line 10G-10G of FIG. 10B;

FIG. 10H is a cross-sectional view of the sole structure of FIG. 10A taken along the line 10H-10H of FIG. 10B;

FIG. 10I is a cross sectional view of the sole structure of FIG. 10A taken along the line 10I-10I of FIG. 10B;

FIG. 10J is a cross-sectional view of the sole structure of FIG. 10A taken along the line 10J-10J of FIG. 10B;

FIG. 10K is a cross-sectional view of the sole structure of FIG. 10A taken along the line 10K-10K of FIG. 10B;

FIG. 10L is a toe view of the sole structure of FIG. 10A; and

FIG. 10M is a heel view of the sole structure of FIG. 10A.

DETAILED DESCRIPTION OF THE DRAWINGS

The following discussion and accompanying figures disclose various embodiments or configurations of a shoe and a sole structure. Although embodiments of a shoe or sole structure are disclosed with reference to a sports shoe, such as a running shoe, tennis shoe, basketball shoe, etc., concepts associated with embodiments of the shoe or the sole structure may be applied to a wide range of footwear and footwear styles, including cross-training shoes, football shoes, golf shoes, hiking shoes, hiking boots, ski and snowboard boots, soccer shoes and cleats, walking shoes, and track cleats, for example. Concepts of the shoe or the sole structure may also be applied to articles of footwear that are considered non-athletic, including dress shoes, sandals, loafers, slippers, and heels.

In addition to footwear, particular concepts described herein may also be applied and incorporated in other types

of apparel or other athletic equipment, including helmets, padding or protective pads, shin guards, and gloves. Even further, particular concepts described herein may be incorporated in cushions, backpack straps, golf clubs, or other consumer or industrial products. Accordingly, concepts described herein may be utilized in a variety of products.

The term "about," as used herein, refers to variation in the numerical quantity that may occur, for example, through typical measuring and manufacturing procedures used for articles of footwear or other articles of manufacture that may include embodiments of the disclosure herein; through inadvertent error in these procedures; through differences in the manufacture, source, or purity of the ingredients used to make the compositions or mixtures or carry out the methods; and the like. Throughout the disclosure, the terms "about" and "approximately" refer to a range of values $\pm 5\%$ of the numeric value that the term precedes.

The terms "weight percent," "wt-%," "percent by weight," "% by weight," and variations thereof, as used herein, refer to the concentration of a substance or component as the weight of that substance or component divided by the total weight, for example, of the composition or of a particular component of the composition, and multiplied by 100. It is understood that, as used herein, "percent," "%," and the like may be synonymous with "weight percent" and "wt-%."

The present disclosure is directed to an article of footwear and/or specific components of the article of footwear, such as an upper and/or a sole or sole structure. The upper may comprise a knitted component, a woven textile, and/or a non-woven textile. The knitted component may be made by knitting of yarn, the woven textile by weaving of yarn, and the non-woven textile by manufacture of a unitary non-woven web. Knitted textiles include textiles formed by way of warp knitting, weft knitting, flat knitting, circular knitting, and/or other suitable knitting operations. The knit textile may have a plain knit structure, a mesh knit structure, and/or a rib knit structure, for example. Woven textiles include, but are not limited to, textiles formed by way of any of the numerous weave forms, such as plain weave, twill weave, satin weave, dobbin weave, jacquard weave, double weaves, and/or double cloth weaves, for example. Non-woven textiles include textiles made by air-laid and/or spun-laid methods, for example. The upper may comprise a variety of materials, such as a first yarn, a second yarn, and/or a third yarn, which may have varying properties or varying visual characteristics.

FIGS. 1-3 depict an embodiment of an article of footwear 100, configured as a shoe, including an upper 102 and a sole structure 104. The upper 102 is attached to the sole structure 104 and together define an interior cavity 106 into which a foot may be inserted. For reference, the article of footwear 100 defines a forefoot region 108, a midfoot region 110, and a heel region 112. The forefoot region 108 generally corresponds with portions of the article of footwear 100 that encase portions of the foot that include the toes, the ball of the foot (shown in FIG. 4), and joints connecting the metatarsals with the toes or phalanges (also shown in FIG. 4). The midfoot region 110 is proximate and adjoining the forefoot region 108, and generally corresponds with portions of the article of footwear 100 that encase the arch of a foot, along with the bridge of a foot. The heel region 112 is proximate and adjoining the midfoot region 110 and generally corresponds with portions of the article of footwear 100 that encase rear portions of the foot, including the heel or calcaneus bone, the ankle, and/or the Achilles tendon.

While only a single article of footwear is depicted, i.e., a shoe that is worn on a left foot of a user, it should be appreciated that the concepts disclosed herein are applicable to a pair of shoes (not shown), which includes a left shoe and a right shoe that may be sized and shaped to receive a left foot and a right foot of a user, respectively. For ease of disclosure, a single shoe will be referenced to describe aspects of the disclosure. The disclosure below with reference to the article of footwear 100 is applicable to both a left shoe and a right shoe. However, in some embodiments there may be differences between a left shoe and a right shoe other than the left/right configuration. Further, in some embodiments, a left shoe may include one or more additional elements that a right shoe does not include, or vice versa.

Many conventional footwear uppers are formed from multiple elements (e.g., textiles, polymer foam, polymer sheets, leather, and synthetic leather) that are joined through bonding or stitching at a seam. In some embodiments, the upper 102 of the article of footwear 100 is formed from a knitted structure or knitted components. In various embodiments, a knitted component may incorporate various types of yarn that may provide different properties to an upper. For example, one area of the upper 102 may be formed from a first type of yarn that imparts a first set of properties, and another area of the upper 102 may be formed from a second type of yarn that imparts a second set of properties. Using this configuration, properties of the upper 102 may vary throughout the upper 102 by selecting specific yarns for different areas of the upper 102. In another example, an upper mesh layer may be warp knit, while a mesh backing layer may comprise a circular knit.

The article of footwear 100 also includes a medial side 116 illustrated in FIG. 1 and a lateral side 118 illustrated in FIG. 2. In particular, when a user is wearing the article of footwear 100, the lateral side 118 corresponds to an outside-facing portion of the article of footwear 100 and the medial side 116 corresponds to an inside-facing portion of the article of footwear 100. As such, left and right articles of footwear have opposing lateral and medial sides, such that the medial sides 116 are closest to one another when a user is wearing the articles of footwear 100, while the lateral sides 118 are defined as the sides that are farthest from one another while being worn. The medial side 116 and the lateral side 118 adjoin one another at opposing, distal ends of the article of footwear 100.

Unless otherwise specified, the forefoot region 108, the midfoot region 110, the heel region 112, the medial side 116, and the lateral side 118 are intended to define boundaries or areas of the article of footwear 100. To that end, the forefoot region 108, the midfoot region 110, the heel region 112, the medial side 116, and the lateral side 118 generally characterize sections of the article of footwear 100. Further, both the upper 102 and the sole structure 104 may be characterized as having portions within the forefoot region 108, the midfoot region 110, the heel region 112, and on the medial side 116 and the lateral side 118. Therefore, the upper 102 and the sole structure 104, and/or individual portions of the upper 102 and the sole structure 104, may include portions thereof that are disposed within the forefoot region 108, the midfoot region 110, the heel region 112, and on the medial side 116 and the lateral side 118.

Referring to FIG. 4, the forefoot region 108 may generally correspond with portions of the article of footwear 100 that encase portions of a foot 10 that include the toes or phalanges 12, the ball 14 of the foot 10, and one or more of the joints 16 that connect the metatarsals 18 of the foot 10 with the toes or phalanges 12. The midfoot region 110 is proximate

mate and adjoins the forefoot region 108. The midfoot region 110 generally corresponds with portions of the article of footwear 100 that encase an arch 20 of a foot 10, along with a bridge 22 of the foot 10. The heel region 112 is proximate to the midfoot region 110 and adjoins the midfoot region 110. The heel region 112 generally corresponds with portions of the article of footwear 100 that encase rear portions of the foot 10, including the heel or calcaneus bone 24, the ankle (not shown), and/or the Achilles tendon (not shown).

The sole structure 104 is connected or secured to the upper 102 and extends between a foot of a user and the ground when the article of footwear 100 is worn by the user. The sole structure 104 may include one or more components, which may include an outsole, a midsole, a heel, a vamp, and/or an insole. For example, in some embodiments, a sole structure may include an outsole that provides structural integrity to the sole structure, along with providing traction for a user, a midsole that provides a cushioning system (e.g., one or more midsole members, which can be configured as cushion layers), and an insole that provides support for an arch of a user. As will be further discussed herein, the sole structure 104 of the present embodiment of the invention includes one or more components that provide the sole structure 104 with preferable spring and damping properties.

The sole structure 104 includes an outsole 130, a first midsole member 132 (e.g., a first cushion layer), a second midsole member 134 (e.g., a second cushion layer), and a sole plate 136 (see, for example FIG. 3). The first midsole member 132, the second midsole member 134, and the sole plate 136 can form a cushioning system of the sole structure 104 (e.g., a midsole of the sole structure 104). The outsole 130 may define a bottom end or surface of the sole structure 104 across the heel region 112, the midfoot region 110, and the forefoot region 108. Further, the outsole 130 may be a ground-engaging portion or include a ground-engaging surface of the sole structure 104 and may be opposite of the insole thereof. The outsole 130 may be formed from one or more materials to impart durability, wear-resistance, abrasion resistance, or traction to the sole structure 104. In some embodiments, the outsole 130 may be formed from rubber, for example.

Together, the first midsole member 132 and the second midsole member 134 form a midsole and may be positioned adjacent to and on top of the outsole 130 in the heel region 112 and partially in the midfoot region 110 and forefoot region 108. The first midsole member 132 and the second midsole member 134 define a cutout portion 138. The first midsole member 132 may be constructed from a thermoplastic material, such as polyurethane (PU) plastic, for example and the second midsole member 134 may be constructed from ethylene-vinyl acetate (EVA), copolymers thereof, or a similar type of material. In other embodiments, each of the first midsole member 132 and the second midsole member 134 may be constructed from the same material.

In other embodiments, the first midsole member 132 and/or the second midsole member 134 may be an EVA-Solid-Sponge ("ESS") material, an EVA foam (e.g., PUMA® ProFoam Lite™, IGNITE Foam), polyurethane, polyether, an olefin block copolymer, a thermoplastic material (e.g., a thermoplastic polyurethane, a thermoplastic elastomer, a thermoplastic polyolefin, etc.), or a supercritical foam. The first midsole member 132 and/or the second midsole member 134 may be a single polymeric material or may be a blend of materials, such as an EVA copolymer, a

thermoplastic polyurethane, a polyether block amide (PEBA) copolymer, and/or an olefin block copolymer.

The sole structure further includes the sole plate 136 disposed between the second midsole member 134 and the upper 102. As shown in FIG. 3, the sole plate 136 extends at least partially through the midfoot region 110 and is exposed at the cutout portion 138. The sole plate 136 is also disposed adjacent an arched section 140 of the article of footwear 100.

In some embodiments, the ground-engaging surface is not continuous along the medial side 116 of the midfoot region 110 of the article of footwear. For example, as illustrated in FIG. 3, the outsole 130 partially surrounds the arched section 140, the first midsole member 132 partially surrounds and partially defines the arched section 140, and the second midsole member 134 surrounds and partially defines the arched section 140.

In some embodiments, the sole plate 136 comprises a polyurethane (PU) plastic, such as a thermoplastic polyurethane (TPU) material, for example. Other thermoplastic elastomers and fiber reinforced thermoplastics consisting of block copolymers are also possible. In other embodiments, the sole plate 136 can include carbon fiber, for example. In some embodiments, these and other rigid, semi-rigid, or spring-like materials and combinations thereof may comprise the sole plate 136. The sole plate 136 can have varied stiffness along the length of the sole plate 136. For example, the stiffness in the forefoot region 108 of the sole plate 136 may be more or less flexible than the midfoot region 110 of the sole plate 136, which may be more or less flexible than the heel region 112 of the sole plate 136. Alternatively, the sole plate 136 can include a uniform stiffness. Additionally, the sole plate 136 may include additional or alternative geometries, such as, for example, notches, curves, protrusions, voids, angled edges, cutouts, etc. In some embodiments, the sole plate 136 can be configured as a shock plate to impart impact protection and facilitate leg muscle tension, thereby relieving stress on a heel, ankle, shin, knees, hips, and/or back of a user.

FIGS. 5A through 5M depict an exemplary embodiment of a sole structure 204 according to one embodiment of the invention. Similar to the sole structure 104, the sole structure 204 is configured to be attached to an upper 202 and together define an interior cavity 206 of an article of footwear 200 (shown in FIG. 5D) into which a foot may be inserted. For reference the sole structure 204 defines a forefoot region 208, a midfoot region 210, and a heel region 212. The forefoot region 208 generally corresponds with portions of an article of footwear, such as the article of footwear 100, for example, that encase portions of the foot that include the toes, the ball of the foot (shown in FIG. 4), and joints connecting the metatarsals with the toes or phalanges (also shown in FIG. 4). The midfoot region 210 is proximate and adjoining the forefoot region 208, and generally corresponds with portions of the article of footwear that encase the arch of a foot, along with the bridge of a foot. The heel region 212 is proximate and adjoining the midfoot region 110 and generally corresponds with portions of the article of footwear that encase rear portions of the foot, including the heel or calcaneus bone, the ankle, and/or the Achilles tendon (shown in FIG. 4).

The sole structure 204 also includes a medial side 216 illustrated in FIG. 5A and a lateral side 218 illustrated in FIG. 5C. In particular, the lateral side 218 corresponds to an outside portion of the article of footwear and the medial side 216 corresponds to an inside portion of the article of footwear. As such, left and right articles of footwear have

US 12,016,422 B2

11

opposing lateral and medial sides, such that the medial sides 216 are closest to one another when a user is wearing the articles of footwear, while the lateral sides 218 are defined as the sides that are farthest from one another while being worn. The medial side 216 and the lateral side 218 adjoin one another at opposing, distal ends of the article of footwear.

Unless otherwise specified, the forefoot region 208, the midfoot region 210, the heel region 212, the medial side 216, and the lateral side 218 are intended to define boundaries or areas of the article of footwear. To that end, the forefoot region 208, the midfoot region 210, the heel region 212, the medial side 216, and the lateral side 218 generally characterize sections of the article of footwear. Further, both the upper 202 and the sole structure 204 may be characterized as having portions within the forefoot region 208, the midfoot region 210, the heel region 212, and on the medial side 216 and the lateral side 218. Therefore, the upper 202 and the sole structure 204, and/or individual portions of the upper 202 and the sole structure 204, may include portions thereof that are disposed within the forefoot region 208, the midfoot region 210, the heel region 212, and on the medial side 216 and the lateral side 218.

The sole structure 204 is connected or secured to the upper 202 and extends between a foot of a user and the ground when the article of footwear is worn by the user. The sole structure 204 may include one or more components, which may include an outsole, a midsole, a heel, a vamp, and/or an insole. For example, in some embodiments, a sole structure may include an outsole that provides structural integrity to the sole structure, along with providing traction for a user, a midsole that provides a cushioning system (e.g., one or more midsole members, which can be configured as cushioning layers), and an insole that provides support for an arch of a user. As will be further discussed herein, the sole structure 204 of the present embodiment of the invention includes one or more components that provide the sole structure 204 with preferable spring and damping properties.

The sole structure 204 includes an outsole 230, a first midsole member 232 (e.g., a first cushion layer), a second midsole member 234 (e.g., a second cushion layer), and a sole plate 236. The first midsole member 232, the second midsole member 234, and the sole plate 236 can form a cushioning system of the sole structure 204 (e.g., a midsole of the sole structure 204). The first midsole member 232 is coupled to the outsole 230 and the second midsole member 234 is positioned between the first midsole member 232 and the upper 202. The outsole 230 may define a bottom end or surface of the sole structure 204 across the heel region 212, the midfoot region 210, and the forefoot region 208. Further, the outsole 230 may be a ground-engaging portion or include a ground-engaging surface of the sole structure 204 and may be opposite of the insole thereof. The outsole 230 may be formed from one or more materials to impart durability, wear-resistance, abrasion resistance, or traction to the sole structure 204. In some embodiments, the outsole 230 may be formed from rubber, for example.

When in a rested state as shown in FIGS. 5A-5M, the sole structure 204 is shaped to define an entry angle 220 in the heel region 212 and an exit angle 222 in the forefoot region 208 with respect to a flat ground surface 224. More specifically, the first midsole member 232, the second midsole member 234, and the outsole 230 can be shaped to define the entry angle 220 and the exit angle 222. The sole structure 204 can also define a substantially flat region 219 that is approximately parallel with the flat ground surface 224. In some embodiments, the entry angle 220 can be about 30

12

degrees. Correspondingly, the sole structure 204 can define an entry region 221 in which a bottom surface 205 (e.g., a ground-engaging surface) of the sole structure 204 curves upwardly to start angling away from the ground surface 224 approximately the area underneath the heel of a user's foot (shown in FIG. 4). In some embodiments, the exit angle 222 can be about 15 degrees. Correspondingly, the sole structure 204 can also define an exit region 223 in which the bottom surface 205 of the sole structure 204 curves to start angling away from the ground surface 224 approximately the area underneath the balls of a user's foot (shown in FIG. 4).

The entry and exit angles 220, 224 can be configured to enhance contact with a user's heel during a heel strike and promoting engagement of a large surface area of the outsole 230 in the forefoot region 208 during a push-off by the user. Accordingly, the entry region 221 can extend rearward from the substantially flat region 219 and the exit region 223 can extend forward from the substantially flat region 219. In some embodiments, the junction between the substantially flat region 219 and the exit region 223 can be located at a widest portion 207 of the sole structure 204 (e.g., at a greatest distance between the medial and lateral sides 216, 218), so as to be aligned proximate to the metatarsal bones of the user.

Due to the curved nature of each of the entry region 221 and the exit region 223, the respective junctions with the substantially flat region 219 can form rocking regions 225, 227 (e.g., rocking members). The rocking regions 225, 227 can create a fulcrum for the sole plate 236. For example, the fulcrum created by the rocking region 227 can create a propulsion lever with the sole plate 236 between a midfoot region and a heel region of the wearer that allows the wearer to accelerate faster and create a toe-off movement where the forefoot region of the wearer propels the wearer forward.

The first midsole member 232 and the second midsole member 234 may be positioned adjacent and on top of the outsole 230 in the heel region 212 and partially in the midfoot region 210 and forefoot region 208, with the first midsole member 232 concentrated in the areas underneath the balls and heel of a user's foot. The first midsole member 232 and the second midsole member 234 define a cutout portion 238. The first midsole member 232 may be constructed from a thermoplastic material, such as PU, for example and the second midsole member 234 may be constructed from EVA, copolymers thereof, or a similar type of material. In other embodiments, each of the first midsole member 232 and the second midsole member 234 may be constructed from the same material. In some embodiments, the first midsole member 232 and/or the second midsole member 234 may be an EVA-Solid-Sponge ("ESS") material, an EVA foam (e.g., PUMA® ProFoam Lite™, IGNITE Foam), polyurethane, polyether, an olefin block copolymer, a thermoplastic material (e.g., a thermoplastic polyurethane, a thermoplastic elastomer, a thermoplastic polyolefin, etc.), or a supercritical foam. The first midsole member 232 and/or the second midsole member 234 may be a single polymeric material or may be a blend of materials, such as an EVA copolymer, a thermoplastic polyurethane, a polyether block amide (PEBA) copolymer, and/or an olefin block copolymer.

The sole structure further includes the sole plate 236 disposed between the second midsole member 234 and the upper 202. As shown in FIGS. 5D and 5E, the sole plate 236 extends through the midfoot region 210 and is exposed at the cutout portion 238 within an arched section 240 illustrated in FIG. 5B. Further illustrated in FIG. 5B, the outsole 230 partially surrounds the arched section 240, the first midsole

US 12,016,422 B2

13

member 232 partially surrounds and partially comprises the arched section 240, and the second midsole member 234 surrounds and partially comprises the arched section 240.

In some embodiments, the ground-engaging surface is not continuous along the medial side 216 of the midfoot region 210 of the article of footwear. Correspondingly, the outsole 230 may comprise multiple outsole portions that are spaced apart from one another, such that the ground engaging surface is not continuous between the outsole portions. For example, as illustrated in FIG. 5B, the outsole 230 includes a first outsole portion 230a positioned in the forefoot region 208 and generally forward of the widest portion 207 (e.g., to extend into the exit region 223). Additionally, the outsole 230 includes a second outsole portion 230b extending from the widest portion 207, along the lateral side 218 of the midfoot region 410, and around a periphery of the heel region 212 to the medial side 216 (e.g., to extend into the entry region 221).

In some embodiments, for example, as illustrated in FIGS. 5B, and 5I-5M, the first midsole member 232 can define a longitudinal channel 233 that extends from the heel region 212 and into the midfoot region 210.

Illustrated in FIG. 5E, the sole plate 236 extends between the heel region 212 and the forefoot region 208 and includes a plurality of cutouts 250 in the forefoot region 208. The plurality of cutouts 250 are oriented to approximate the angle of the path of the ball of user's foot (shown in FIG. 4) from medial side to lateral side. The plurality of cutouts 250 provide reliefs in the sole plate 250 allowing it to bend and flex more easily at the cutouts 250. Generally, the sole plate 236 has a shape that is similar to but proportionally smaller than the midsole member 232 in the midfoot and heel regions 210, 212. In the forefoot region 218, the sole plate 236 has an irregular periphery, wherein the periphery extends inward in the spaces between the cutouts 250. Decreasing the width of the sole plate 236 in the spaces between the cutouts 250 increases the flexibility of the sole plate 236 in the forefoot region 218 by making the sole plate 236 easier to bend. Illustrated in FIGS. 5F through 5K, the sole plate 236 has a uniform thickness. In some embodiments, the thickness of the sole plate 236 is approximately 1.2 millimeters. In some embodiments, the sole plate 236 can be configured as a shock plate to impart impact protection and facilitate leg muscle tension thereby relieving stress on a heel, ankle, shin, knees, hips, and/or back of a user.

Continuing, FIGS. 5F and 5G show cross-sectional views of the forefoot region 208 of the article of footwear 200 along lines 5F-5F and 5G-5G in FIG. 5B. In FIG. 5F, the sole plate 236 is shown extending between the medial side 216 and the lateral side 218 and positioned within a pocket 242 and exposed along the top of the second midsole member 234. In FIG. 5G, the second midsole member 234 is shown extending through one of the plurality of cutouts 250 and contacting the upper 202. FIG. 5G further shows the first midsole member 232 in contact with the second midsole member 234 and the outsole 230 along the medial side 216.

FIGS. 5H and 5I illustrate cross-sectional views of the midfoot region 210 of the article of footwear 200 along lines 5H-5H and 5I-5I of FIG. 5B. The sole plate 236 is positioned within the pocket 242 and exposed along the top of the second midsole member 234 in FIG. 5H. Further, the second midsole member 234 extends continuously from medial side 216 to the lateral side 218 and the first midsole member 232 is sandwiched between the second sole member 234 and the outsole 230, with both the first midsole member 232 and the outsole 230 also extending continuously from the medial side 216 to the lateral side 218. Looking at FIGS. 5A, 5C,

14

and 5D, and as mentioned above, this portion of the sole structure 204 is located underneath the ball of a user's foot (shown in FIG. 4) and creates a rocking member (i.e., a rocking region) with a fulcrum proximate to the metatarsal bones of the user. The position of the sole plate 236 in relation to the first and second midsole members 232, 234 effectively adjusts the running posture of the user to be a forward tilt and moves the running motion of the user toward their forefoot.

Continuing, in FIG. 5G, the sole plate 236 is also shown positioned within and exposed along the top of the second midsole member 234 but also exposed through the cutout portion 238. The first midsole member 232 is only shown along the lateral side 218. Along the medial side 216, the second midsole member 234 is spaced from the ground surface 224 and is configured to be capable of engaging an elevated ground surface or other external surface at the midfoot region 210.

Further, FIGS. 5J and 5K show cross-sectional views of the heel region 212 of the article of footwear 200 along lines 5J-5J and 5K-5K of FIG. 5B. The sole plate 236 is positioned within the pocket 242 of the second midsole member 234 as shown in both FIGS. 5J and 5K, but is exposed through the cutout portion 238 in at least the area of the heel region 212 of the sole structure 204 shown in FIG. 5J. Additionally, the first midsole member 232 is positioned between the second midsole member 234 and the outsole 230 along both the medial side 216 and the lateral side 218 of the heel region 212. In FIG. 5K, the sole plate 236 is shown positioned within the pocket 242 and exposed along the top of the second midsole member 234. Further, the second midsole member 234 extends continuously from the medial side 216 to the lateral side 218. The first midsole member 232 is positioned between the second midsole member 234 and the outsole 230. Both the first midsole member 232 and the outsole 230 extend continuously from the medial side 216 to the lateral side 218.

In some embodiments, the sole plate 236 comprises a PU plastic, such as a TPU material, for example. Other thermoplastic elastomers and fiber reinforced thermoplastics consisting of block copolymers are also possible. In other embodiments, the sole plate 236 can include carbon fiber, for example. However, these and other rigid, semi-rigid, or spring-like materials and combinations thereof may comprise the sole plate 236. The sole plate 236 can have varied stiffness along the length of the sole plate 236. For example, the stiffness in the forefoot region 208 of the sole plate 236 may be more or less flexible than the midfoot region 210 of the sole plate 236, which may be more or less flexible than the heel region 212 of the sole plate 236. Alternatively, the sole plate 236 can include a uniform stiffness. Additionally, the sole plate 236 may include additional or alternative geometries, such as, for example, notches, curves, protrusions, voids, angled edges, cutouts, etc.

FIGS. 5L and 5G illustrate a toe view and a heel view, respectively, of the article of footwear 200. The outsole 230 extends up and around the second midsole member 234 and at least a portion of the upper 202 in the front of the forefoot region 208 (shown in FIGS. 5A, 5C and 5D).

FIGS. 6A through 6M depict an exemplary embodiment of a sole structure 304 according to one embodiment of the disclosure. Similar to the sole structures 104 and 204, the sole structure 304 is configured to be attached to an upper 302 and together define an interior cavity of an article of footwear 300 (shown in FIG. 6D) into which a foot may be inserted. For reference the sole structure 304 defines a forefoot region 308, a midfoot region 310, and a heel region

US 12,016,422 B2

15

312. The forefoot region 308 generally corresponds with portions of an article of footwear, such as the article of footwear 100, for example, that encase portions of the foot that include the toes, the ball of the foot (shown in FIG. 4), and joints connecting the metatarsals with the toes or phalanges (also shown in FIG. 4). The midfoot region 310 is proximate and adjoining the forefoot region 308, and generally corresponds with portions of the article of footwear that encase the arch of a foot, along with the bridge of a foot. The heel region 312 is proximate and adjoining the midfoot region 310 and generally corresponds with portions of the article of footwear that encase rear portions of the foot, including the heel or calcaneus bone, the ankle, and/or the Achilles tendon (shown in FIG. 4).

The sole structure 304 also includes a medial side 316 illustrated in FIG. 6A and a lateral side 318 illustrated in FIG. 6C. In particular, the lateral side 318 corresponds to an outside portion of the article of footwear and the medial side 316 corresponds to an inside portion of the article of footwear. As such, left and right articles of footwear have opposing lateral and medial sides, such that the medial sides 316 are closest to one another when a user is wearing the articles of footwear, while the lateral sides 318 are defined as the sides that are farthest from one another while being worn. The medial side 316 and the lateral side 318 adjoin one another at opposing, distal ends of the article of footwear.

Unless otherwise specified, the forefoot region 308, the midfoot region 310, the heel region 312, the medial side 316, and the lateral side 318 are intended to define boundaries or areas of the article of footwear. To that end, the forefoot region 308, the midfoot region 310, the heel region 312, the medial side 316, and the lateral side 318 generally characterize sections of the article of footwear. Further, both the upper 302 and the sole structure 304 may be characterized as having portions within the forefoot region 308, the midfoot region 310, the heel region 312, and on the medial side 316 and the lateral side 318. Therefore, the upper 302 and the sole structure 304, and/or individual portions of the upper 302 and the sole structure 304, may include portions thereof that are disposed within the forefoot region 308, the midfoot region 310, the heel region 312, and on the medial side 316 and the lateral side 318.

The sole structure 304 is connected or secured to the upper 302 and extends between a foot of a user and the ground when the article of footwear is worn by the user. The sole structure 304 may include one or more components, which may include an outsole, a midsole, a heel, a vamp, and/or an insole. For example, in some embodiments, a sole structure may include an outsole that provides structural integrity to the sole structure, along with providing traction for a user, a midsole that provides a cushioning system (e.g., one or more midsole members, which can be configured as cushioning layers), and an insole that provides support for an arch of a user. As will be further discussed herein, the sole structure 304 of the present embodiment of the invention includes one or more components that provide the sole structure 304 with preferable spring and damping properties.

The sole structure 304 includes an outsole 330, a midsole member 332 (e.g., a first midsole member or cushion layer), a sole plate 336, and a cushion layer 352 (e.g., a second midsole member or cushion layer). The midsole member 332, the cushion layer 352, and the sole plate 336 can form a cushioning system of the sole structure 304 (e.g., a midsole of the sole structure 304). The outsole 330 may define a bottom end or surface of the sole structure 304 across the heel region 312, the midfoot region 310, and the forefoot

16

region 308. Further, the outsole 330 may be a ground-engaging portion or include a ground-engaging surface of the sole structure 304 and may be opposite of the insole thereof. The outsole 330 may be formed from one or more materials to impart durability, wear-resistance, abrasion resistance, or traction to the sole structure 304. In some embodiments, the outsole 330 may be formed from rubber, for example. Similar to the outsole 230, the outsole 330 can have an entry angle 320 in the heel region 312 and an exit angle 322 in the forefoot region 308 relative to a ground surface 324. Further, in some embodiments, the entry angle 320 can be about 30 degrees, and in some embodiments the exit angle 322 can be about 15 degrees.

Accordingly, when in a rested state as shown in FIGS. 6A-6M, the sole structure 304 is shaped to define an entry angle 320 in the heel region 312 and an exit angle 322 in the forefoot region 308 with respect to a flat ground surface 324. The sole structure 304 can also define a substantially flat region 319 that is approximately parallel with the flat ground surface 324. Correspondingly, the sole structure 304 can define an entry region 321 in which a bottom surface 305 (e.g., a ground-engaging surface) of the sole structure 304 curves upwardly to start angling away from the ground surface 324 approximate the area underneath the heel of a user's foot (shown in FIG. 4). Correspondingly, the sole structure 304 can also define an exit region 323 in which the bottom surface 305 of the sole structure 304 curves upwardly to start angling away from the ground surface 324 approximate the area underneath the ball of a user's foot (shown in FIG. 4).

The entry and exit angles 320, 324 can be configured to enhance contact with a user's heel during a heel strike and promote engagement of a large surface area of the outsole 330 in the forefoot region 308 during a push-off by the user. Accordingly, the entry region 321 can extend rearward from the substantially flat region 319 and the exit region 323 can extend forward from the substantially flat region 319. In some embodiments, the junction between the substantially flat region 319 and the exit region 323 can be located at a widest portion 307 of the sole structure 304 (e.g., at a greatest distance between the medial and lateral sides 316, 318), so as to be aligned proximate to the metatarsal bones of the user.

Due to the curved nature of each of the entry region 321 and the exit region 323, the respective junctions with the substantially flat region 319 can form rocking regions 325, 327 (e.g., rocking members). The rocking regions 325, 327 can create a fulcrum for the sole plate 336. For example, the fulcrum created by the rocking region 327 can create a propulsion lever with the sole plate 336 between a midfoot region and a heel region of the wearer that allows the wearer to accelerate faster and create a toe-off movement where the forefoot region of the wearer propels the wearer forward.

The midsole member 332 may be positioned adjacent and on top of the outsole 330 in the heel region 312 and partially in the midfoot region 310 and forefoot region 308. The midsole member 332 may define a cutout portion 338. The midsole member 332 can be constructed from a PU plastic, such as a thermoplastic polyurethane (TPU) material, for example. The midsole member 332 may be constructed from a thermoplastic elastomer material such as a polyether block amide (PEBA). One example of a PEBA material is PEBAX® foam. In some embodiments, the midsole member 332 can be constructed from an EVA-Solid-Sponge ("ESS") material, an EVA foam (e.g., PUMA® ProFoam Lite™, IGNITE Foam), polyurethane, polyether, an olefin block copolymer, a thermoplastic material (e.g., a thermoplastic

US 12,016,422 B2

17

polyurethane, a thermoplastic elastomer, a thermoplastic polyolefin, etc.), or a supercritical foam. The midsole member 332 may be a single polymeric material or may be a blend of materials, such as an EVA copolymer, a thermoplastic polyurethane, a PEBA copolymer, and/or an olefin block copolymer.

The sole structure further includes the sole plate 336 disposed between the midsole member 332 and the upper 302. As shown in FIGS. 6D and 6E, the sole plate 336 extends through the midfoot region 310 and is exposed at the cutout portion 338 within an arched section 340 illustrated in FIG. 6B. Further illustrated in FIG. 6B, the outsole 330 partially surrounds the arched section 340 and the midsole member 332 partially surrounds and partially comprises the arched section 340.

In some embodiments, the ground-engaging surface is not continuous along the medial side 316 of the midfoot region 310 of the article of footwear. Correspondingly, the outsole 330 may comprise multiple outsole portions that are spaced apart from one another, such that the ground engaging surface is not continuous between the outsole portions. For example, as illustrated in FIG. 6B, the outsole 330 includes a first outsole portion 330a positioned in the forefoot region 308 and generally forward of the widest portion 307 (e.g., to extend into the exit region 323). Additionally, the outsole 330 includes a second outsole portion 330b extending from the widest portion 307, along the lateral side 318 of the midfoot region 410, and around a periphery of the heel region 312 to the medial side 316 (e.g., to extend into the entry region 321).

In some embodiments, for example, as illustrated in FIGS. 6B, and 6I-6M, the first midsole member 332 can define a longitudinal channel 333 that extends from the heel region 312 and into the midfoot region 310.

Illustrated in FIG. 6E, the sole plate 336 extends between the heel region 312 and the forefoot region 308. Illustrated in FIGS. 6F through 6K, the sole plate 336 has a uniform thickness throughout of approximately 0.8 millimeters. Generally, the sole plate 336 has a shape that is similar to but proportionally smaller than the midsole member 332 throughout the forefoot, midfoot, and heel regions 308, 310, 312 (shown in FIG. 6E). In some embodiments, the sole plate 336 comprises carbon fiber, for example. In other embodiments, the sole plate 336 can include a PU plastic, such as a thermoplastic polyurethane (TPU) material, for example. Other thermoplastic elastomers and fiber reinforced thermoplastics consisting of block copolymers are also possible. However, these and other rigid, semi-rigid, or spring-like materials and combinations thereof may comprise the sole plate 336. In some embodiments, the sole plate 336 can be configured as a shock plate to impart impact protection and facilitate leg muscle tension thereby relieving stress on a heel, ankle, shin, knees, hips, and/or back of a user.

The sole plate 336 can have varied stiffness along the length of the sole plate 336. For example, the stiffness in the forefoot region 308 of the sole plate 336 may be more or less flexible than the midfoot region 310 of the sole plate 336, which may be more or less flexible than the heel region 312 of the sole plate 336. Alternatively, the sole plate 336 can include a uniform stiffness. Additionally, the sole plate 336 may include additional or alternative geometries, such as, for example, notches, curves, protrusions, voids, angled edges, cutouts, etc. The sole plate 336 further defines an outer periphery that would fit into a peripheral envelope of a pocket formed in the sole structure 304 (e.g., a midsole member thereof).

18

The cushion layer 352 extends between the heel region 312 and the midfoot region 310 as illustrated in FIG. 6J and is positioned on top at least a portion of the sole plate 336 and between the sole plate 336 and the upper 302. The cushion layer 352 is configured as a thin foam layer having a thickness of approximately 4 millimeters in the heel region 312 and a portion of the midfoot region 310. In some embodiments, the cushion layer 352 can be constructed from a thermoplastic elastomer material such as a polyether block amide (PEBA). One example of a PEBA material is PEBAX® foam. In a portion of the midfoot region 310 the cushion layer 352 tapers to a thickness of zero so that there is little to no cushion layer 352 present in the forefoot region 308. However, in some embodiments, the cushion layer 352 can extend at least partially into the forefoot region 308.

Continuing, FIGS. 6F and 6G show cross-sectional views of the forefoot region 308 of the article of footwear 300 along lines 6F-6F and 6G-6G in FIG. 6B. In both FIGS. 6F and 6G the sole plate 336 is shown positioned within a pocket 342 and exposed along the top of the midsole member 332 and in contact with the upper 302. The sole plate 336 also extends between the medial side 316 and the lateral side 318.

FIGS. 6H and 6I illustrate cross-sectional views of the midfoot region 310 along lines 6H-6H and 6I-6I of FIG. 6B. In FIG. 6H, the sole plate 336 is shown positioned within the pocket 342 in the top of the midsole member 332. The cushion layer 352 is also positioned within the pocket 342 of the midsole member 332 and on top of the sole plate 336 (e.g., so that the sole plate 336 is embedded in the sole structure 304, with the cushion layer 352 positioned generally above the midsole member 332). Accordingly, the sole plate 336 is positioned between the midsole member 332 and the cushion layer 352. Put another way, the cushion layer 352 is positioned generally above the midsole member 352 and the sole plate 336 so that the cushion layer 352 is between the upper 302 and each of the midsole member 352 and the sole plate 336. Further, the midsole member 332 extends from the medial side 316 to the lateral side 318 and the outsole 330 extends across the bottom of the midsole member 332. Looking at FIGS. 6A, 6C, and 6D, and as mentioned above, this portion of the sole structure 304 is located underneath the ball of a user's foot (shown in FIG. 4) and creates a rocking member (i.e., a rocking region) with a fulcrum proximate to the metatarsal bones of the user. The position of the sole plate 336 in relationship to the midsole member 332 effectively adjusts the running posture of the user to be a forward tilt and moves the running motion of the user toward their forefoot.

In FIG. 6G, the sole plate 336 is also shown positioned within the pocket 342 of the midsole member 332 and exposed through the cutout portion 338. The cushion layer 352 is also positioned within the pocket 342 and on top of the sole plate 336. Along the medial side 316, the midsole member 332 is spaced from the ground surface 324 and is configured to be capable of engaging an elevated ground surface or other external surface at the midfoot region 310.

Further, FIGS. 6J and 6K show cross-sectional views of the heel region 312 along lines 6J-6J and 6K-6K of FIG. 6B. In FIG. 6J, the sole plate 336 is shown positioned within the pocket 342 of the midsole member 332 and exposed through the cutout portion 338. The pocket 342 and the sole plate 336 are correspondingly shaped such that a peripheral envelope of the pocket 342 bounds and can be in contact with an outer periphery of the sole plate 336. As such, the pocket 342 can be shaped to receive the sole plate 336, and the sole plate 336 can be shaped to be received within the pocket 336.

Additionally, the cushion layer 352 is also positioned within the pocket 342 and on top of the sole plate 336. Accordingly, the sole plate 336 can be contained in the pocket 342 by the cushion layer 352. Further, the midsole member 332 on the medial side 316 is spaced from the ground surface, but less spaced than in the part of the midfoot region 310 shown in FIG. 6I. In FIG. 6K, the sole plate 336 is shown positioned within the pocket 342 of the midsole member 332. Additionally, the cushion layer 352 is also positioned within the pocket 342 and on top of the sole plate 336. Further, the midsole member 332 extends continuously from the medial side 316 to the lateral side 318.

FIGS. 6L and 6G illustrate a toe view and a heel view, respectively, of the article of footwear 300. The outsole 330 extends up and around the midsole member 332 and at least a portion of the upper 302 in the front of the forefoot region 308 (shown in FIGS. 6A, 6C and 6D).

FIGS. 7A through 7M illustrate another embodiment of an article of footwear 400 according to the invention. In many aspects, the article of footwear 400 is similar to the article of footwear 200 described above and similar numbering in the 400 series is used for the article of footwear 400. For example, the article of footwear 400 has an upper 402, a sole structure 404, an interior cavity 406 defined by the combination of the upper 402 and the sole structure 404, a forefoot region 408, a midfoot region 410, a heel region 412, a medial side 416, and a lateral side 418. Further, the sole structure 404 has an outsole 430, a first midsole member 432 (e.g., a first cushion layer), a second midsole member 434 (e.g., a second cushion layer) with a pocket 442, a sole plate 436, an arched section 440, and a cutout portion 438. The first midsole member 432, the second midsole member 434, and the sole plate 436 can form a cushioning system of the sole structure 404 (e.g., a midsole of the sole structure 404). Additionally, the sole structure 404 is shaped to define an entry angle 420 in the heel region 412 and an exit angle 422 in the forefoot region 408 with respect to a flat ground surface 424. Similarly, in some embodiments, the entry angle 420 can be about 30 degrees and the sole structure 404 can start angling away from the ground surface 424 approximate the area underneath the heel of a user's foot (shown in FIG. 4). Further, in some embodiments, the exit angle 422 can be about 15 degrees and can start angling away from the ground surface 424 approximate the area underneath the balls of a user's foot (shown in FIG. 4).

Additionally, the first midsole member 432, the second midsole member 434, and the sole plate 436 can be similarly constructed as the first midsole member 232, the second midsole member 234, and the sole plate 236. For example, the first and second midsole members 432, 434 can be formed from a PU plastic, such as a thermoplastic polyurethane (TPU) material, ethylene-vinyl acetate (EVA) polymer, copolymers thereof, or a similar type of material and the sole plate 436 can be formed from a PU plastic, such as a thermoplastic polyurethane (TPU) material, thermoplastic elastomers and fiber reinforced thermoplastics consisting of block copolymers, carbon fiber, or other rigid, semi-rigid, or spring-like materials and combinations thereof.

In some aspects, however, the articles of footwear 200, 400 differ from each other. For example, the sole plate 436 has a shape that is similar to but proportionally smaller than the midsole member 432 throughout the forefoot, midfoot, and heel regions 408, 410, 412 (shown in FIG. 7E).

Additionally, as shown in FIG. 7D and FIGS. 7G, 7I, and 7J, which are cross-sectional views taken along lines 7G-7G, 7I-7I, and 7J-7J in FIG. 7B within the forefoot region 408, the midfoot region 410, and the heel region 412, respec-

tively, the first midsole member 432 and the second midsole member 434 are positioned differently within the sole structure 404 than the first midsole member 232 and the second midsole member 234 in the sole structure 204. For example, the second midsole member 434 extends around the front of the first midsole member 432 in the forefoot region 408 (shown in FIG. 7D).

FIGS. 8A through 8M illustrate another embodiment of an article of footwear 500 according to the invention. In many aspects, the article of footwear 500 is similar to the article of footwear 300 described above and similar numbering in the 500 series is used for the article of footwear 500. For example, the article of footwear 500 has an upper 502, a sole structure 504, an interior cavity 506 defined by the combination of the upper 502 and the sole structure 504, a forefoot region 508, a midfoot region 510, a heel region 512, a medial side 516, and a lateral side 518. Further, the sole structure 504 has an outsole 530, a midsole member 532 (i.e., a first midsole member or cushion layer of a midsole) with a pocket 542, a sole plate 536, a cushion layer 552 (i.e., a second midsole member or cushion layer of a midsole), an arched section 540, and a cutout portion 538. The sole plate 536 is disposed between the midsole member 532 and the cushion layer 552 and the cushion layer 552 is positioned between the upper 502 and each of the midsole member 532 and the sole plate 536. The sole plate 536 extends at least partially through the midfoot region 510 and is exposed at the cutout portion 538 of the midsole member 532. The midsole member 532, the cushion layer 552, and the sole plate 536 can form a cushioning system of the sole structure 504 (e.g., a midsole of the sole structure 504). Additionally, the sole structure 504 is shaped to define an entry angle 520 in the heel region 512 and an exit angle 522 in the forefoot region 508 with respect to a flat ground surface 524. Similarly, in some embodiments, the entry angle 520 can be about 30 degrees and the sole structure 504 can start angling away from the ground surface 524 approximate the area underneath the heel of a user's foot (shown in FIG. 4). Further, in some embodiments, the exit angle 522 can be about 15 degrees and can start angling away from the ground surface 524 approximate the area underneath the balls of a user's foot (shown in FIG. 4).

Accordingly, when in a rested state as shown in FIGS. 8A-8M, the sole structure 504 is shaped to define an entry angle 520 in the heel region 512 and an exit angle 522 in the forefoot region 508 with respect to a flat ground surface 524. The sole structure 504 can also define a substantially flat region 519 that is approximately parallel with the flat ground surface 524. The substantially flat region 519 can extend from a first end 560 to a second end 562. As illustrated in FIGS. 8A, 8C, and 8D, the first end 560 can be in the heel region 512 and the second end 562 can be in the forefoot region 508.

Correspondingly, the sole structure 504 can define an entry region 521 in which a bottom surface 505 (e.g., a ground engaging surface) of the sole structure 504 curves upwardly to start angling away from the ground surface 524 approximate the area underneath the heel of a user's foot (shown in FIG. 4) by at least the entry angle 520. In that regard, the entry region 521 can include an angled portion 557 (e.g., an angled region). The angled portion 557 extends from a first end 564 to a second end 566. The first end 564 is positioned proximate the substantially flat region 519 such that the first end 564 is positioned below a heel end 568 of the sole plate 536 and such that the first end 564 is closer to the forefoot region 508 than is the heel end 568 of the sole plate 536. The second end 566 is positioned above the heel

end 568 of the sole plate 536 and the second end 566 is positioned farther from the forefoot region 508 than is the heel end 568 of the sole plate 536. The angled portion 557 is substantially flat between the first end 564 and the second end 566. For example, between the first end 564 and the second end 566, the angle portion 557, and thus the entry region 521, can be at about the entry angle 520 to enhance contact with a user's heel during a heel strike. In that regard, the angled portion 557 forms a portion of the bottom surface 505 of the sole structure 504 that is configured to engage the ground during a heel strike. In some cases, the second end 566 of the angled portion 557, and thus the entry region 521, defines a heel end 570 of the bottom surface 505. Accordingly, the ground-engaging bottom surface 505 extends above the heel end 570 of the sole plate 536.

Correspondingly, the sole structure 504 can also define an exit region 523 in which the bottom surface 505 of the sole structure 504 curves upwardly to start angling away from the ground surface 524 approximate the area underneath the balls of a user's foot (shown in FIG. 4) by at least the exit angle 524. In that regard, the exit region 523 can include an angled portion 559 (e.g., an angled region). The angled portion 559 extends from a first end 574 to a second end 576. The first end 574 is positioned proximate the substantially flat region 519 such that the first end 574 is positioned below a toe end 578 of the sole plate 536 and such that the first end 574 is closer to the heel region 512 than is the toe end 578 of the sole plate 536. The angled portion 559 is substantially flat between the first end 574 and the second end 576. For example, between the first end 574 and the second end 576 the angled portion 559, and thus the exit region 523, can be at about the exit angle 522 to adjust the running posture of the user to be a forward tilt to move the running motion of the user toward their forefoot to propel the user forward. In that regard the angled portion 559 forms a portion of the bottom surface 505 of the sole structure 504 that is configured to engage the ground during toe-off. In some cases, the second end 576 of the angled portion 559, and thus the exit region 523, defines a toe end 580 of the bottom surface 505.

The entry and exit angles 520, 524 can be configured to enhance contact with a user's heel during a heel strike and promoting engagement of a large surface area of the outsole 530 in the forefoot region 508 during a push-off by the user. Accordingly, the entry region 521 can extend rearward from the substantially flat region 519 and the exit region 523 can extend forward from the substantially flat region 519. In some embodiments, the junction between the substantially flat region 519 and the exit region 523 can be located at a widest portion 507 of the sole structure 504 (e.g., at a greatest distance between the medial and lateral sides 516, 518), so as to be aligned proximate to the metatarsal bones of the user.

Due to the curved nature of each of the entry region 521 and the exit region 523, the respective junctions with the substantially flat region 519 can form rocking regions 525, 527 (e.g., rocking members). The rocking regions 525, 527 are formed as convex regions of the bottom surface 505 that can create a fulcrum for the sole plate 536. For example, the fulcrum created by the rocking region 525 can create a propulsion lever with the sole plate 536 between a midfoot region and a heel region of the wearer that allows the wearer to accelerate faster and create a toe-off movement where the forefoot region of the wearer propels the wearer forward. More specifically, the fulcrum created by the rocking region 525 can create a propulsion lever with the sole plate 536 between the entry region 521 and the substantially flat region 519. The rocking region 525 is an entirely convex

region that extends between the first end 560 of the substantially flat region 519 and the first end 564 of the substantially flat angled portion 557. The entry region 521 includes the rocking region 525 and the angled portion 557, such that the entry region 521 curves upwardly from the substantially flat region 519 at the rocking region 525 to form the angled portion 557. In that regard, the rocking region 525 forms an upwardly curved portion (e.g., an upwardly curved entry region). The fulcrum created by the rocking region 527 can also act as a propulsion level with the sole plate 536 proximate to the metatarsal bones of the user by adjusting the running posture of the user to be a forward tilt and moves the running motion of the user toward their forefoot. The fulcrum created by the rocking region 527 can create a propulsion lever with the sole plate 536 between the exit region 523 and the substantially flat region 519. The rocking region 527 is an entirely convex region that extends between the second end 562 of the substantially flat region 519 and the first end 574 of the substantially flat angled portion 559. The exit region 523 includes the rocking region 527 and the angled portion 559, such that the exit region 523 curves upwardly from the substantially flat region 519 at the rocking region 527 to form the angled portion 559. In that regard, the rocking region 527 forms an upwardly curved portion (e.g., an upwardly curved exit region).

Additionally, the midsole member 532, the sole plate 536, and the cushion layer 552 can be similarly constructed as the midsole member 332, the sole plate 336, and the cushion layer 352. For example, the midsole member 532 can be formed from a PU plastic, such as a thermoplastic polyurethane (TPU) material; the sole plate 536 can be formed from a PU plastic, such as a thermoplastic polyurethane (TPU) material, thermoplastic elastomers and fiber reinforced thermoplastics consisting of block copolymers, carbon fiber, or other rigid, semi-rigid, or spring-like materials and combinations thereof; and the cushion layer 552 can be formed from a thermoplastic elastomer material, for example, a polyether block amide (PEBA), including PEBAX® foam. In some embodiments, the cushion layer member 552 can be constructed from an EVA-Solid-Sponge ("ESS") material, an EVA foam (e.g., PUMA® ProFoam Lite™, IGNITE Foam), polyurethane, polyether, an olefin block copolymer, a thermoplastic material (e.g., a thermoplastic polyurethane, a thermoplastic elastomer, a thermoplastic polyolefin, etc.), or a supercritical foam.

Another similarity is that the sole plate 536 has a shape that is similar to but proportionally smaller than the midsole member 532 throughout the forefoot, midfoot, and heel regions 508, 510, 512 (shown in FIG. 8E). Additionally, the pocket 542 and the sole plate 536 are correspondingly shaped such that a peripheral envelope of the pocket 542 bounds and can be in contact with an outer periphery of the sole plate 536. Put another way, the pocket 542 can be shaped to receive the sole plate 536, and the sole plate 536 can be shaped to be received in the pocket 542. Further, the cushion layer 552 can also be positioned within the pocket 542, such that the sole plate 536 can be secured in the pocket 542 by the cushion layer 352. In particular, the sole plate 536 can be secured between the midsole member 532 and the cushion layer 552, with the midsole member 532 in contact with a first side of the sole plate 536 and the cushion layer 552 in contact with a second side of the sole plate 536 that is opposite the first side. It is appreciated that the cushioning layer 552 can be coupled to the midsole member 532. Moreover, the position of the sole plate 536 in relation to the first midsole member 532 and the cushion layer 552 can

effectively adjust the running posture of the user to be a forward tilt and moves the running motion of the user toward their forefoot.

In some aspects, however, the articles of footwear **300**, **500** differ from each other. For example, the cushion layer is different. As shown in FIGS. **8D** and **8G**, which is a cross-sectional view taken along line **8G-8G** in FIG. **8B** within the forefoot region **508**, the cushion layer **552** extends into the forefoot region **508**.

Further, in some embodiments, the ground-engaging surface is not continuous along the medial side **516** of the midfoot region **510** of the article of footwear. Correspondingly, the outsole **530** may comprise multiple outsole portions that are spaced apart from one another, such that the ground engaging surface is not continuous between the outsole portions. For example, as illustrated in FIG. **8B**, the outsole **530** includes a first outsole portion **530a** positioned in the forefoot region **508** and generally forward of the widest portion **507** (e.g., to extend into the exit region **523**). Additionally, the outsole **530** includes a second outsole portion **530b** extending from the widest portion **507** and along the lateral side **518** of the midfoot region **410** to the heel region **512**. Further, the outsole **530** can include a third outsole portion **530c** that is coupled to the medial side **516** of the first midsole member in the heel region **512** (e.g., to extend into the entry region **521**).

In some embodiments, for example, as illustrated in FIGS. **8B**, and **8I-8M**, the first midsole member **532** can define a longitudinal channel **533** that extends from the heel region **512** and into the midfoot region **510**. As illustrated, the second and third outsole portions **530b**, **530c** are positioned on opposite sides of the longitudinal channel **533** so that the ground engaging surface is not continuous between the medial and lateral sides **516**, **518** in the heel region **512**.

FIGS. **9A** through **9M** illustrate another embodiment of an article of footwear **600** according to the invention. In many aspects, the article of footwear **600** is similar to the article of footwear **500** described above and similar numbering in the **600** series is used for the article of footwear **600**. For example, the article of footwear **600** has an upper **602**, a sole structure **604**, an interior cavity **606** defined by the combination of the upper **602** and the sole structure **604**, a forefoot region **608**, a midfoot region **610**, a heel region **612**, a medial side **616**, and a lateral side **618**. Further, the sole structure **604** has an outsole **630**, a midsole member **632** (e.g., a first midsole member or cushion layer of a midsole) with a pocket **642**, a sole plate **636**, a cushion layer **652** (e.g., a second midsole member or cushion layer of a midsole), an arched section **640**, and a cutout portion **638**. The sole plate **636** is disposed between the midsole member **632** and the cushion layer **652**. The sole plate **636** extends at least partially through the midfoot region **610** and is exposed at the cutout portion **638** of the midsole member **632**. The cushion layer **652** is positioned between the upper **602** and each of the midsole member **632** and the sole plate **636**. The midsole member **632**, the cushion layer **652**, and the sole plate **636** can form a cushioning system of the sole structure **604** (e.g., a midsole of the sole structure **604**). Additionally, the sole structure **604** is shaped to define an entry angle **620** in the heel region **612** and an exit angle **622** in the forefoot region **608** with respect to a flat ground surface **624**. Similarly, in some embodiments, the entry angle **620** can be about 30 degrees and the sole structure **604** can start angling away from the ground surface **624** approximate the area underneath the heel of a user's foot (shown in FIG. **4**). Further, in some embodiments, the exit angle **622** can be about 15 degrees and can start angling away from the ground

surface **624** approximate the area underneath the balls of a user's foot (shown in FIG. **4**).

Accordingly, when in a rested state as shown in FIGS. **9A-9M**, the sole structure **604** is shaped to define an entry angle **620** in the heel region **612** and an exit angle **622** in the forefoot region **608** with respect to a flat ground surface **624**. The sole structure **604** can also define a substantially flat region **619** that is approximately parallel with the flat ground surface **624**. The substantially flat region **619** can extend from a first end **660** to a second end **662**. As illustrated in FIGS. **8A**, **8C**, and **8D**, the first end **660** can be in the heel region **612** and the second end **662** can be in the forefoot region **608**.

Correspondingly, the sole structure **604** can define an entry region **621** in which a bottom surface **605** (e.g., a ground engaging surface) of the sole structure **604** curves upwardly to start angling away from the ground surface **624** approximate the area underneath the heel of a user's foot (shown in FIG. **4**) by at least the entry angle **620**. In that regard, the entry region **621** can include an angled portion **657** (e.g., an angled region). The angled portion **657** extends from a first end **664** to a second end **666**. The first end **664** is positioned proximate the substantially flat region **619** such that the first end **664** is positioned below a heel end **668** of the sole plate **636** and such that the first end **664** is closer to the forefoot region **608** than is the heel end **668** of the sole plate **636**. The second end **666** is positioned above the heel end **668** of the sole plate **636** and the second end **666** is positioned farther from the forefoot region **608** than is the heel end **668** of the sole plate **636**. The angled portion **657** is substantially flat between the first end **664** and the second end **666**. For example, between the first end **664** and the second end **666**, the angled portion **657**, and thus the entry region **621**, can be at about the entry angle **620** to enhance contact with a user's heel during a heel strike. In that regard, the angled portion **657** forms a portion of the bottom surface **605** of the sole structure **604** that is configured to engage the ground during a heel strike. In some cases, the second end **666** of the angled portion **657**, and thus the entry region **621**, defines a heel end **670** of the bottom surface **605**. Accordingly, the ground-engaging bottom surface **605** extends above the heel end **670** of the sole plate **636**.

Correspondingly, the sole structure **604** can also define an exit region **623** in which the bottom surface **605** of the sole structure **604** curves upwardly to start angling away from the ground surface **624** approximate the area underneath the balls of a user's foot (shown in FIG. **4**) by at least the exit angle **624**. In that regard, the exit region **623** can include an angled portion **659** (e.g., an angled region). The angled portion **659** extends from a first end **674** to a second end **676**. The first end **674** is positioned proximate the substantially flat region **619** such that the first end **674** is positioned below a toe end **678** of the sole plate **636** and such that the first end **674** is closer to the heel region **612** than is the toe end **678** of the sole plate **636**. The second end **676** is positioned above the toe end **678** of the sole plate **636** and the second end **676** is positioned farther from the heel region **612** than is the toe end **678** of the sole plate **636**. The angled portion **659** is substantially flat between the first end **674** and the second end **676**. For example, between the first end **674** and the second end **676**, the angled portion **659**, and thus the exit region **623**, can be at about the exit angle **622** to adjust the running posture of the user to be a forward tilt to move the running motion of the user toward their forefoot to propel the user forward. In that regard the angled portion **659** forms a portion of the bottom surface **605** of the sole structure **604** that is configured to engage the ground during toe-off. In

25

some cases, the second end 676 of the angled portion 659, and thus the exit region 623, defines a toe end 680 of the bottom surface 605.

The entry and exit angles 620, 624 can be configured to enhance contact with a user's heel during a heel strike and promoting engagement of a large surface area of the outsole 630 in the forefoot region 608 during a push-off by the user. Accordingly, the entry region 621 can extend rearward from the substantially flat region 619 and the exit region 623 can extend forward from the substantially flat region 619. In some embodiments, the junction between the substantially flat region 619 and the exit region 623 can be located at a widest portion 607 of the sole structure 604 (e.g., at a greatest distance between the medial and lateral sides 616, 618), so as to be aligned proximate to the metatarsal bones of the user.

Due to the curved nature of each of the entry region 621 and the exit region 623, the respective junctions with the substantially flat region 619 can form rocking regions 625, 627 (e.g., rocking members). The rocking regions 625, 627 are formed as convex regions of the bottom surface 505 that can create a fulcrum for the sole plate 636. For example, the fulcrum formed by the rocking region 625 can create a propulsion lever with the sole plate 636 between a midfoot region and a heel region of the wearer that allows the wearer to accelerate faster and create a toe-off movement where the forefoot region of the wearer propels the wearer forward. More specifically, the fulcrum created by the rocking region 625 can create a propulsion lever with the sole plate 636 between the entry region 621 and the substantially flat region 619. The rocking region 625 is an entirely convex region that extends between the first end 660 of the substantially flat region 619 and the first end 664 of the substantially flat angled portion 657. The entry region 621 includes the rocking region 625 and the angled portion 657, such that the entry region 621 curves upwardly from the substantially flat region 619 at the rocking region 625 to form the angled portion 657. In that regard, the rocking region 625 forms an upwardly curved portion (e.g., an upwardly curved entry region). The fulcrum formed by the rocking region 627 can also act as a propulsion level with the sole plate 636 proximate to the metatarsal bones of the user by adjusting the running posture of the user to be a forward tilt and moves the running motion of the user toward their forefoot. The fulcrum created by the rocking region 627 can create a propulsion lever with the sole plate 636 between the exit region 623 and the substantially flat region 619 (e.g., proximate the widest portion 607 of the sole structure 604). The rocking region 627 is an entirely convex region that extends between the second end 662 of the substantially flat region 619 and the first end 674 of the substantially flat angled portion 659. The exit region 623 includes the rocking region 627 and the angled portion 659, such that the exit region 623 curves upwardly from the substantially flat region 619 at the rocking region 627 to form the angled portion 659. In that regard, the rocking region 627 forms an upwardly curved portion (e.g., an upwardly curved exit region).

Additionally, the midsole member 632, the sole plate 636, and the cushion layer 652 can be similarly constructed as the midsole member 532, the sole plate 536, and the cushion layer 552. For example, the midsole member 632 can be formed from a PU plastic, such as a thermoplastic polyurethane (TPU) material; the sole plate 636 can be formed from a PU plastic, such as a thermoplastic polyurethane (TPU) material, thermoplastic elastomers and fiber reinforced thermoplastics consisting of block copolymers, carbon fiber, or

26

other rigid, semi-rigid, or spring-like materials and combinations thereof; and the cushion layer 652 can be formed from a thermoplastic elastomer material, for example, a polyether block amide (PEBA), including PEBAX® foam.

Further, the sole plate 636 has a shape that is similar to but proportionally smaller than the midsole member 632 throughout the forefoot, midfoot, and heel regions 608, 610, 612 (shown in FIG. 9E). Additionally, the pocket 642 and the sole plate 636 are correspondingly shaped such that a peripheral envelope of the pocket 642 bounds and can be in contact with an outer periphery of the sole plate 636. Put another way, the pocket 642 can be shaped to receive the sole plate 636, and the sole plate 636 can be shaped to be received within the pocket 642. Further, the cushion layer 652 can also be positioned within the pocket 642, such that the sole plate 636 can be secured in the pocket 642 by the cushion layer 352. In particular, the sole plate 636 can be secured between the midsole member 632 and the cushion layer 652, with the midsole member 632 in contact with a first side of the sole plate 636 and the cushion layer 652 in contact with a second side of the sole plate 636 that is opposite the first side. The cushion layer 652 may extend to cover the entirety of the second side of the sole plate 636. It is appreciated that the cushioning layer 652 can be coupled to the midsole member 632. Moreover, the position of the sole plate 636 in relation to the first midsole member 632 and the cushion layer 652 can effectively adjust the running posture of the user to be a forward tilt and moves the running motion of the user toward their forefoot.

In some embodiments, the ground-engaging surface is not continuous along the medial side 616 of the midfoot region 610 of the article of footwear. Correspondingly, the outsole 630 may comprise multiple outsole portions that are spaced apart from one another, such that the ground engaging surface is not continuous between the outsole portions. For example, as illustrated in FIG. 8B, the outsole 630 includes a first outsole portion 630a positioned in the forefoot region 608 and generally forward of the widest portion 607 (e.g., to extend into the exit region 623). Additionally, the outsole 630 includes a second outsole portion 630b extending from the widest portion 607 and along the lateral side 618 of the midfoot region 410 to the heel region 612. Further, the outsole 630 can include a third outsole portion 630c that is coupled to the medial side 616 of the first midsole member in the heel region 612 (e.g., to extend into the entry region 621).

In some aspects, however, the articles of footwear 500, 600 differ from each other. For example, as shown in FIGS. 9D, 9E and FIG. 9F, which is a cross-sectional view taken along line 9F-9F in FIG. 9B within the forefoot region 608, the cushion layer 652 extends even farther into the forefoot region 608. Further, as shown in FIGS. 9D-9M, the cushion layer 652 can be configured to cover the entirety of the second side of the sole plate 636 when the sole plate 636 and the cushion layer 652 are received within the pocket 642. Additionally, the midsole member 632 has a more consistent thickness from the midfoot region 610 through the forefoot region 608 and is thinner than the midsole member 532 near the midfoot region 610 and thicker in the portion beneath a user's toes in the forefoot region 608. The midsole member 632 also has a chamber 654 extending upward into the midsole member 632 and extending from the forefoot region 608 into the cutout portion 638. In some embodiments, the chamber 654 can be arch-shaped. Looking at FIGS. 9F-9H, in those embodiments, the height of the chamber 654 (defined as measured from the ground surface 624 to the top of the chamber 654 taken along the shortest path) can be

about half the thickness of the midsole member 632 (defined as measured from the top of the chamber 654 to the top of the midsole member 632 taken along the shortest path). In some embodiments, the width of the chamber 654 can decrease moving from the forefoot region 608 to the cutout portion 638. In some embodiments the area of the cross-section of the chamber 654 can remain constant moving from the forefoot region 608 to the cutout portion 638 (e.g., as the width of the chamber 654 decreases, the height of the chamber 654 increases).

FIGS. 10A through 10M illustrate another embodiment of an article of footwear 700 according to the invention. In many aspects, the article of footwear 700 is similar to the article of footwear 300 described above and similar numbering in the 700 series is used for the article of footwear 700. For example, the article of footwear 700 has an upper 702, a sole structure 704, an interior cavity 706 defined by the combination of the upper 702 and the sole structure 704, a forefoot region 708, a midfoot region 710, a heel region 712, a medial side 716, and a lateral side 718. Further, the sole structure 704 has an outsole 730, a midsole member 732 (e.g., a first midsole member or cushion layer) with a pocket 742, a sole plate 736, a cushion layer 752 (e.g., a second midsole member or cushion layer), an arched section 740, and a cutout portion 738. The midsole member 732, the cushion layer 752, and the sole plate 736 can form a cushioning system of the sole structure 704 (e.g., a midsole of the sole structure 704). Additionally, the sole structure 704 is shaped to define an entry angle 720 in the heel region 712 and an exit angle 722 in the forefoot region 708 with respect to a flat ground surface 724. Similarly, in some embodiments, the entry angle 720 can be about 30 degrees and the sole structure 704 can start angling away from the ground surface 724 approximate the area underneath the heel of a user's foot (shown in FIG. 4). Further, in some embodiments, the exit angle 722 can be about 15 degrees and can start angling away from the ground surface 724 approximate the area underneath the balls of a user's foot (shown in FIG. 4).

Additionally, the midsole member 732, the sole plate 736, and the cushion layer 752 can be similarly constructed as the midsole member 332, the sole plate 336, and the cushion layer 352. For example, the midsole member 732 can be formed from a PU plastic, such as a thermoplastic polyurethane (TPU) material; the sole plate 736 can be formed from a PU plastic, such as a thermoplastic polyurethane (TPU) material, thermoplastic elastomers and fiber reinforced thermoplastics consisting of block copolymers, carbon fiber, or other rigid, semi-rigid, or spring-like materials and combinations thereof; and the cushion layer 752 can be formed from a thermoplastic elastomer material, for example, a polyether block amide (PEBA), including PEBAX® foam.

Another similarity is that the sole plate 736 has a shape that is similar to but proportionally smaller than the midsole member 732 throughout the forefoot, midfoot, and heel regions 708, 710, 712 (shown in FIG. 10E). Additionally, the pocket 742 and the sole plate 736 are correspondingly shaped such that a peripheral envelope of the pocket 742 bounds and can be in contact with an outer periphery of the sole plate 736. Put another way, the pocket 742 can be shaped to receive the sole plate 736, and the sole plate 736 can be shaped to be received in the pocket 742. Further, the cushion layer 752 can also be positioned within the pocket 742, such that the sole plate 736 can be secured in the pocket 742 by the cushion layer 352. In particular, the sole plate 736 can be secured between the midsole member 732 and the cushion layer 752, with the midsole member 732 in contact

with a first side of the sole plate 736 and the cushion layer 752 in contact with a second side of the sole plate 736 that is opposite the first side. It is appreciated that the cushioning layer 752 can be coupled to the midsole member 732. Moreover, the position of the sole plate 736 in relation to the first midsole member 732 and the cushion layer 752 can effectively adjust the running posture of the user to be a forward tilt and moves the running motion of the user toward their forefoot.

In some aspects, however, the articles of footwear 300, 700 differ from each other. For example, the cushion layer is different. As shown in FIGS. 10D and 10F, which is a cross-sectional view taken along line 10G-10G in FIG. 10B within the forefoot region 708, the cushion layer 752 extends into the forefoot region 708.

The above-described sole plates, such as sole plates 136, 236, 336, 436, 536, 636, and 736 provide a rigid sole that can promote a faster takeoff when running. In particular, the fulcrum of the rocking member creates a propulsion lever between a midfoot region and a heel region of the wearer that allows the wearer to accelerate faster and create a toe-off movement where the forefoot region of the wearer propels the wearer forward. Further, embodiments of the sole structures described herein can provide a training aid or tool that can be used to strengthen entire leg and foot muscles of a wearer and adjust their running posture to a forward-tilt position that promotes constant muscle tension.

Any of the embodiments described herein may be modified to include any of the structures or methodologies disclosed in connection with different embodiments. Further, the present disclosure is not limited to articles of footwear of the type specifically shown. Still further, aspects of the articles of footwear of any of the embodiments disclosed herein may be modified to work with any type of footwear, apparel, or other athletic equipment.

As noted previously, it will be appreciated by those skilled in the art that while the invention has been described above in connection with particular embodiments and examples, the invention is not necessarily so limited, and that numerous other embodiments, examples, uses, modifications and departures from the embodiments, examples and uses are intended to be encompassed by the claims attached hereto. The entire disclosure of each patent and publication cited herein is incorporated by reference, as if each such patent or publication were individually incorporated by reference herein. Various features and advantages of the invention are set forth in the following claims.

INDUSTRIAL APPLICABILITY

Numerous modifications to the present invention will be apparent to those skilled in the art in view of the foregoing description. Accordingly, this description is to be construed as illustrative only and is presented for the purpose of enabling those skilled in the art to make and use the invention and to teach the best mode of carrying out same. The exclusive rights to all modifications which come within the scope of the appended claims are reserved.

We claim:

1. A sole structure for an article of footwear having an upper, the sole structure comprising:
 - an outsole;
 - a midsole member disposed between the outsole and the upper, the midsole member having a pocket extending from a heel region to a forefoot region; and
 - a sole plate extending from the heel region into the forefoot region.

US 12,016,422 B2

29

wherein, in the heel region, the sole structure is shaped to define an entry region that is configured to increase contact at a ground engaging surface of the sole structure during a heel strike, the entry region curving upward to form an angled portion that is substantially flat between a first end and a second end so that the angled portion is angled at an entry angle relative to a flat ground surface, and

wherein the first end of the angled portion is below a heel end of the sole plate and the second end of the angled portion is above the heel end of the sole plate to define a heel end of the ground engaging surface that is above the heel end of the sole plate.

2. The sole structure of claim 1, wherein the midsole member includes a first midsole member and a second midsole member disposed between the first midsole member and the upper.

3. The sole structure of claim 2, wherein the second midsole member is positioned on top of the sole plate so that the sole plate is positioned between the first midsole member and the second midsole member.

4. The sole structure of claim 1, wherein the sole plate is a carbon fiber plate that is similarly shaped to and proportionally smaller than the midsole member in at least one of the forefoot region, a midfoot region, or the heel region of the sole structure.

5. The sole structure of claim 1, wherein the midsole member defines a longitudinal channel extending from a heel end of the sole structure and into a midfoot region.

6. The sole structure of claim 5, wherein the outsole includes a first outsole member and a second outsole member that are separated from one another by the longitudinal channel so that the ground engaging surface is not continuous across the heel region between a lateral side and medial side of the sole structure.

7. The sole structure of claim 1, wherein the outsole includes a first outsole member in the forefoot region and a second outsole member in the heel region, and

wherein the ground engaging surface is not continuous along a medial side of a midfoot region of the sole structure.

8. The sole structure of claim 1, wherein the first end of the angled portion is closer to the forefoot region than is the heel end of the sole plate and the second end of the angled portion is farther from the forefoot region than is the heel end of the sole plate.

9. The sole structure of claim 1, wherein the outsole extends onto the angled portion.

10. The sole structure of claim 1, wherein the entry region includes a first rocking region that extends from a substantially flat region to the angled portion, the first rocking region being entirely convex between the substantially flat region and the angled portion.

11. The sole structure of claim 10, wherein, in the forefoot region, the sole structure is shaped to define an exit region that curves to angle away from the flat ground surface, and wherein the exit region includes a second rocking region that forms a fulcrum proximate a widest portion of the sole structure, the second rocking region forming a propulsion lever with the sole plate that is configured to propel a user forward during toe off.

12. The sole structure of claim 11, wherein the angled portion of the entry region is a first angled portion and the exit region includes a second angled portion extending from a third end positioned at the second rocking region to a fourth end that corresponds with a toe end of the ground engaging surface, the second angled portion being substan-

30

tially flat between the third end and the fourth end so that the second angled portion is angled at an exit angle relative to a flat ground surface.

13. The sole structure of claim 12, wherein the entry angle is thirty degrees and the exit angle is fifteen degrees.

14. A sole structure for an article of footwear having an upper, the sole structure comprising:

an outsole;

a midsole extending between the outsole and the upper, the midsole including:

a first midsole member coupled to the outsole and extending from a forefoot region to a heel region of the sole structure, the first midsole member defining an entry region at a heel end in which the first midsole member defines a substantially flat angled portion that is angled away from a ground surface by a first angle that is configured to increase contact at a ground engaging surface of the first midsole member during a heel strike, and

a second midsole member coupled to the upper and positioned between the first midsole member and the upper, the second midsole member extending from the heel region to the forefoot region; and

a sole plate positioned within the midsole between the first midsole member and the second midsole member, the sole plate being exposed at a cutout portion in the first midsole member,

wherein the substantially flat angled portion of the entry region extends from a first end to a second end, the first end being positioned below a heel end of the sole plate and the second end being positioned above the heel end of the sole plate.

15. The sole structure of claim 14, wherein the sole plate is comprised of carbon fibers and extends from the heel region to the forefoot region.

16. The sole structure of claim 14, wherein the outsole extends at least partially into the entry region.

17. The sole structure of claim 14, wherein the first midsole member further defines an exit region in the forefoot region in which the first midsole member curves away from the ground surface from approximately a widest portion of the sole structure to extend to a toe end of the sole structure.

18. The sole structure of claim 17, wherein the first midsole member defines a substantially flat region between the entry region and the exit region.

19. The sole structure of claim 18, wherein the exit region includes a rocking region that extends from the substantially flat region, the rocking region creating a fulcrum for the sole plate to help propel a user forward during toe off.

20. The sole structure of claim 19, wherein the fulcrum is positioned to be proximate metatarsal bones of a user.

21. The sole structure of claim 14, wherein the first midsole member defines a pocket and at least one of the sole plate or the second midsole member is disposed at least partially within the pocket.

22. A sole structure for an article of footwear having an upper, the sole structure comprising:

a first midsole member extending from a forefoot region to a heel region of the sole structure, the first midsole member defining an entry region in a heel region that is configured to increase contact with a ground surface during a heel strike, an exit region in a forefoot region, and a substantially flat region extending between the entry region and the exit region;

an upwardly curved entry region along the bottom surface in the heel region,

US 12,016,422 B2

31

a second midsole member positioned between the first midsole member and the upper, the second midsole member extending from the heel region to the forefoot region; and
a sole plate positioned between the first midsole member and the second midsole member, the sole plate including a heel end that is disposed in the heel region, and the sole plate being exposed at a cutout portion in the first midsole member,
wherein the entry region includes an angled portion and a first rocking region, the first rocking region extending between the substantially flat region and the angled portion, the angled portion extending from a first end that is positioned at the first rocking region and below the heel end of the sole plate to a second end that is positioned above the heel end of the sole plate, and the angled portion being substantially flat between the first end and the second end to define an entry angle relative to the substantially flat region, and

32

wherein the exit region is shaped to create a fulcrum for the sole plate to help propel a user forward during toe off.

23. The sole structure of claim 22, wherein the sole plate defines a first region with a first stiffness and a second region with a second stiffness that is greater than the first stiffness.

24. The sole structure of claim 22, further including an outsole coupled to the first midsole member, the outsole including a first outsole portion positioned in the forefoot region and a second outsole portion positioned in the heel region, the first outsole portion and the second outsole portion being spaced from one another.

25. The sole structure of claim 22, wherein the exit region includes a second rocking region that curves upwardly from approximately a widest portion of the sole structure to extend to a toe end of the sole structure.

* * * * *

EXHIBIT E



US0D1022421S

(12) **United States Design Patent** (10) **Patent No.:** **US D1,022,421 S**
Redon (45) **Date of Patent:** **** Apr. 16, 2024**

(54) **SHOE**
 (71) Applicant: **PUMA SE**, Herzogenaurach (DE)
 (72) Inventor: **Arnaud Redon**, Nuremberg (DE)
 (73) Assignee: **PUMA SE**, Herzogenaurach (DE)
 (**) Term: **15 Years**
 (21) Appl. No.: **29/891,188**
 (22) Filed: **May 2, 2023**

D158,403 S 5/1950 Pierce
 2,578,591 A 12/1951 Phillips
 D208,393 S 8/1967 Onitsuka
 3,402,484 A 9/1968 Brutting
 D232,200 S 7/1974 Inohara
 (Continued)

FOREIGN PATENT DOCUMENTS

CA 38477 S 12/1974
 CA 70286 S 3/1992
 (Continued)

OTHER PUBLICATIONS

[Adidas Adizero], available on Amazon.com, Nov. 23, 2015 [online], [May 5, 2023]. Available from the internet URL: https://www.amazon.com/adidas-Adizero-Prime-Collegiate-White/dp/B0119E37WS/ref=cm_cr_ar_p_d_product_top?ie=UTF8 (Year: 2015).*
 (Continued)

Primary Examiner — Jennifer L Rempfer
Assistant Examiner — Adrienne Corna
 (74) *Attorney, Agent, or Firm* — Quarles & Brady LLP

(57) **CLAIM**

The ornamental design for a shoe, as shown and described.

DESCRIPTION

FIG. 1 is a top, right, and front perspective view of an ornamental design for a shoe;
 FIG. 2 is a left side elevational view of the shoe of FIG. 1;
 FIG. 3 is a right side elevational view of the shoe of FIG. 1; and,
 FIG. 4 is a bottom plan view of the shoe of FIG. 1.
 The dash-dash-dash broken lines are included for the purpose of illustrating portions of the shoe that form no part of the claimed design. A transition in tonal contrast shown along the front cushion is claimed.

1 Claim, 4 Drawing Sheets

Related U.S. Application Data

(63) Continuation of application No. 29/797,495, filed on Jun. 30, 2021.
 (51) **LOC (14) Cl.** **02-04**
 (52) **U.S. Cl.**
 USPC **D2/947**; D2/962; D2/954; D2/959;
 D2/906
 (58) **Field of Classification Search**
 USPC D2/902, 906, 908, 916, 918, 925,
 D2/946–962, 972, 977
 CPC A43B 13/00; A43B 13/02; A43B 13/023;
 A43B 13/026; A43B 13/04; A43B 13/08;
 A43B 13/10; A43B 13/12; A43B 13/14;
 A43B 13/20; A43B 13/24; A43B 13/28;
 A43B 13/30; A43B 13/32; A43B 13/34;
 A43B 13/36; A43B 13/181; A43B
 13/187; A43B 13/189; A43B 13/223
 See application file for complete search history.

(56) **References Cited**

U.S. PATENT DOCUMENTS

324,065 A 8/1885 Andrews
 413,693 A 10/1889 Walker
 634,588 A 10/1899 Roche
 1,088,328 A 2/1914 Cucinotta et al.
 1,827,514 A 10/1931 Golden

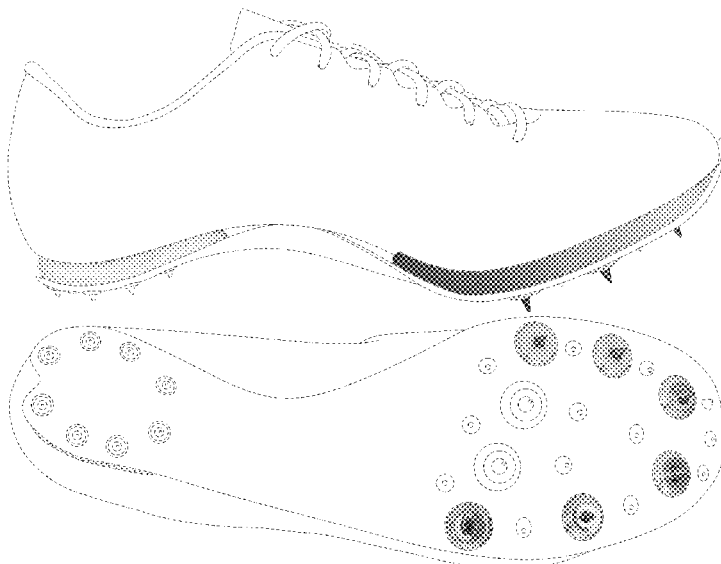

US D1,022,421 S

Page 2

(56)

References Cited

U.S. PATENT DOCUMENTS

4,020,569	A	5/1977	Fukuoka	8,112,909	B2	2/2012	Kubo et al.
4,241,523	A	12/1980	Daswick	8,122,615	B2	2/2012	Lucas et al.
4,348,821	A	9/1982	Daswick	D666,795	S	9/2012	Shaffer
4,392,312	A	7/1983	Crowley	D672,123	S	12/2012	Williams, Jr.
4,463,505	A	8/1984	Duclos	8,341,856	B2	1/2013	Smith et al.
4,492,046	A	1/1985	Kosova	8,393,028	B2	3/2013	Namkook et al.
4,510,700	A	4/1985	Brown	D680,308	S	4/2013	Hardman
4,542,598	A	9/1985	Misevich et al.	8,418,379	B2	4/2013	Nishiwaki et al.
4,910,884	A	3/1990	Lindh et al.	D685,166	S	7/2013	Hatfield
5,024,007	A	6/1991	DuFour	D688,037	S *	8/2013	Dekovic D2/962
5,052,130	A	10/1991	Barry et al.	D690,088	S	9/2013	Hardman
D327,165	S	6/1992	Hatfield	D692,217	S	10/2013	Fogg
5,138,776	A	8/1992	Levin	8,567,094	B2	10/2013	Lubart
5,191,727	A	3/1993	Barry et al.	D694,498	S	12/2013	Carboy
5,203,095	A	4/1993	Allen	D694,499	S	12/2013	Williams, Jr.
D341,480	S	11/1993	Saito	8,613,149	B2	12/2013	Schwirian
5,339,544	A *	8/1994	Caberlotto A43B 23/0255 36/43	8,615,901	B2	12/2013	Caine et al.
D350,638	S	9/1994	Yoshikawa	D707,428	S *	6/2014	Seamarks D2/947
5,353,523	A	10/1994	Kilgore et al.	8,776,397	B2	7/2014	Borel et al.
5,435,079	A	7/1995	Gallegos	D710,579	S	8/2014	Williams, Jr.
5,461,800	A	10/1995	Luthi et al.	D713,625	S	9/2014	Raasch
5,528,842	A	6/1996	Ricci et al.	D713,626	S	9/2014	Raasch
D377,411	S	1/1997	Murray	D714,035	S	9/2014	O'Connor
5,592,757	A	1/1997	Jackinsky	8,850,718	B2	10/2014	Lubart
D378,472	S	3/1997	Bramani	8,919,015	B2	12/2014	Holt et al.
5,706,589	A	1/1998	Marc	8,945,449	B2	2/2015	Atwal et al.
D396,139	S	7/1998	Dietrich	8,978,274	B2	3/2015	Auger et al.
5,806,209	A	9/1998	Crowley et al.	8,984,775	B2	3/2015	Dombrow et al.
D401,741	S	12/1998	Clarke	9,009,988	B2	4/2015	Jacobs et al.
5,875,567	A	3/1999	Bayley	D731,767	S	6/2015	Lan
D415,607	S	10/1999	Merceron	9,066,559	B2	6/2015	Butler
6,029,374	A	2/2000	Herr et al.	9,144,265	B2	9/2015	Lubart
D423,201	S	4/2000	Wilson	9,167,864	B1	10/2015	Piontkowski et al.
D454,426	S	3/2002	Wilson	D743,153	S	11/2015	Taylor
6,502,330	B1	1/2003	David et al.	9,179,733	B2	11/2015	Peyton et al.
6,505,421	B1	1/2003	Vaz	9,204,686	B2	12/2015	Baum et al.
D473,042	S	4/2003	Wilson	9,210,967	B2	12/2015	Gerber
D473,047	S	4/2003	Wilson	D746,560	S	1/2016	Verfl
D476,800	S	7/2003	Fuerst	D747,083	S	1/2016	Verfl
6,775,930	B2	8/2004	Fuerst	9,241,533	B2	1/2016	Heard et al.
D498,901	S	11/2004	Hawker	9,259,050	B2	2/2016	Smith et al.
6,826,852	B2	12/2004	Fusco	D756,620	S	5/2016	Boys
6,857,205	B1	2/2005	Fusco et al.	9,326,562	B2	5/2016	Weidl et al.
D507,398	S	7/2005	Recchi	9,339,079	B2	5/2016	Lucas et al.
6,944,972	B2	9/2005	Schmid	9,375,048	B2	6/2016	James et al.
D511,617	S	11/2005	Matis	D768,969	S	10/2016	Boys
7,013,582	B2	3/2006	Lucas et al.	D770,739	S	11/2016	Nethongkome
7,016,867	B2	3/2006	Lyden	D770,740	S	11/2016	Teteriatnikov
7,096,605	B1	8/2006	Kozo et al.	9,491,983	B2	11/2016	Rushbrook
7,100,308	B2	9/2006	Aveni	9,516,916	B2	12/2016	Derrier
7,100,309	B2	9/2006	Smith et al.	9,549,589	B2	1/2017	Auger et al.
7,107,235	B2	9/2006	Lyden	D779,175	S	2/2017	Greenhalgh
7,152,343	B2	12/2006	Whatley	9,572,394	B2	2/2017	Heard et al.
7,219,447	B2	5/2007	LeVert	9,572,398	B2	2/2017	Hurd et al.
7,350,320	B2	4/2008	Chandler et al.	D782,790	S	4/2017	Lee
7,401,419	B2	7/2008	Lucas et al.	9,615,625	B1	4/2017	Huard et al.
7,401,422	B1	7/2008	Scholz et al.	9,661,896	B2	5/2017	Elliott et al.
7,434,337	B2	10/2008	Gibert et al.	D789,054	S	6/2017	Shyllon
7,484,317	B2	2/2009	Kita et al.	D790,169	S	6/2017	da Costa Pereira Machado
7,513,065	B2	4/2009	Kita et al.	D790,183	S	6/2017	VanHook
7,624,515	B2	12/2009	Kita et al.	9,668,540	B2	6/2017	Scofield et al.
7,644,518	B2	1/2010	Chandler et al.	D791,453	S	7/2017	McMillan
D615,738	S	5/2010	Teteriatnikov	D793,046	S	8/2017	Lee
7,707,743	B2	5/2010	Schindler et al.	D795,541	S	8/2017	Henrichot
7,786,193	B2	8/2010	Wilding et al.	D796,168	S	9/2017	Shyllon
7,832,117	B2	11/2010	Auger et al.	D796,799	S	9/2017	Shyllon
7,886,461	B2	2/2011	Sato	9,750,306	B2	9/2017	Baum et al.
7,900,376	B2	3/2011	Rabushka	D798,551	S	10/2017	Shyllon
D637,803	S	5/2011	Alvear	D798,554	S	10/2017	Swierszczk
7,950,091	B2	5/2011	Auger et al.	D798,555	S	10/2017	Enayah
7,987,618	B2	8/2011	Nishiwaki et al.	D798,558	S	10/2017	Pauk
8,028,442	B2	10/2011	Hodgson	9,775,404	B2	10/2017	Fyden
8,074,377	B2	12/2011	Nishiwaki et al.	9,820,528	B2	11/2017	Reinhardt et al.
8,079,160	B2	12/2011	Baucom et al.	9,820,529	B2	11/2017	Droege et al.
				D810,411	S	2/2018	Klein
				9,883,714	B2	2/2018	Cavaliere et al.
				9,894,958	B2	2/2018	Cheney et al.
				D812,871	S	3/2018	Reyes
				D815,816	S	4/2018	Cin

US D1,022,421 S

Page 3

(56)	References Cited	2003/0233770 A1	12/2003	Foscaro
	U.S. PATENT DOCUMENTS	2004/0107601 A1	6/2004	Schmid
		2004/0200097 A1*	10/2004	Boyd A43B 5/02 36/74
D815,817 S	4/2018 Cin	2005/0102858 A1	5/2005	Yen
D815,818 S	4/2018 Cin	2005/0126039 A1	6/2005	LeVert
D815,820 S	4/2018 Cin	2005/0166422 A1	8/2005	Schaeffer et al.
D815,821 S	4/2018 Cin	2005/0262739 A1	12/2005	McDonald
D815,822 S	4/2018 Cin	2006/0196084 A1*	9/2006	Kos A43B 1/0081 36/133
D815,823 S	4/2018 Cin			
9,930,934 B2	4/2018 Cook et al.	2007/0043630 A1	2/2007	Lyden
D816,310 S	5/2018 Cooper	2007/0101617 A1	5/2007	Brewer et al.
D816,311 S	5/2018 Cin	2007/0240331 A1	10/2007	Borel
D816,959 S	5/2018 Cin	2007/0266593 A1	11/2007	Schindler et al.
D816,960 S	5/2018 Cin	2007/0271818 A1	11/2007	Rabushka
D817,614 S	5/2018 Cin	2008/0072462 A1	3/2008	Fusco
D817,615 S	5/2018 Cin	2008/0189982 A1	8/2008	Krafsur
D817,616 S	5/2018 Cin	2009/0100718 A1*	4/2009	Gerber A43C 15/04 36/67 A
9,961,959 B2	5/2018 Gerber			
9,968,157 B2	5/2018 Wardlaw et al.	2009/0183393 A1	7/2009	Lee
9,968,160 B2	5/2018 Peyton	2009/0307925 A1	12/2009	Pfister
10,010,135 B2	7/2018 Lovell et al.	2010/0175280 A1	7/2010	Rinehart, Jr.
10,010,137 B2	7/2018 Foxen	2010/0186261 A1	7/2010	Baker
10,016,919 B2	7/2018 Cook et al.	2010/0218397 A1	9/2010	Nishiwaki et al.
10,111,491 B2	10/2018 Tanabe et al.	2010/0263228 A1	10/2010	Kang
10,159,303 B2	12/2018 Wang et al.	2011/0138652 A1	6/2011	Lucas
10,165,821 B2	1/2019 Truelsen	2012/0317835 A1	12/2012	Raysse et al.
10,165,824 B2	1/2019 Auger et al.	2013/0192090 A1	8/2013	Smith
10,226,097 B2	3/2019 Farris et al.	2014/0068966 A1	3/2014	Chaffin
10,231,517 B2	3/2019 Baucom et al.	2014/0101972 A1	4/2014	Ha
10,271,614 B2	4/2019 Huard et al.	2014/0230280 A1	8/2014	Heard et al.
D847,478 S	5/2019 Fracassi	2014/0230283 A1*	8/2014	Cordova A43B 5/185 36/103
10,299,535 B2	5/2019 Hurd et al.			
10,314,365 B2	6/2019 James et al.			
10,314,367 B2	6/2019 Kilgore et al.	2014/0237852 A1	8/2014	Oberschneider et al.
D853,097 S	7/2019 Cass	2014/0245640 A1	9/2014	Heard et al.
D853,701 S	7/2019 Hong	2015/0047224 A1	2/2015	Zhao et al.
10,349,700 B2	7/2019 Amis et al.	2015/0107132 A1	4/2015	Takeshita
D855,301 S	8/2019 Williams, Jr.	2016/0262492 A1	9/2016	Fujita
D862,046 S	10/2019 Page	2017/0079376 A1	3/2017	Bunnell et al.
10,433,616 B2	10/2019 Takeshita et al.	2017/0105477 A1	4/2017	Wilkerson
10,441,027 B2	10/2019 Bartel et al.	2017/0150779 A1	6/2017	Walker et al.
10,448,701 B2	10/2019 Farris et al.	2017/0245590 A1	8/2017	Kohatsu et al.
10,448,704 B2	10/2019 Dupre et al.	2018/0027922 A1	2/2018	Orand
D870,429 S	12/2019 Becker	2018/0035752 A1	2/2018	Walker et al.
10,512,301 B2	12/2019 Peyton	2018/0042338 A1	2/2018	Orand
10,517,350 B2	12/2019 Orand et al.	2018/0153254 A1	6/2018	Fusco et al.
10,517,351 B2	12/2019 Arciuolo	2018/0168281 A1	6/2018	Case et al.
10,524,536 B2	1/2020 Bunnell et al.	2018/0199666 A1	7/2018	Moriyasu et al.
10,548,368 B2	2/2020 Bartel et al.	2018/0199675 A1	7/2018	Cook et al.
10,595,587 B2	3/2020 Cook et al.	2018/0235310 A1	8/2018	Wardlaw et al.
D882,918 S	5/2020 Kosenick	2018/0271215 A1	9/2018	Foxen
10,653,205 B2	5/2020 Orand	2018/0338568 A1	11/2018	Chambers et al.
D885,718 S	6/2020 Roulo	2018/0352902 A1	12/2018	Wardle
D889,798 S	7/2020 Vella	2019/0082781 A1	3/2019	Iuchi et al.
10,743,606 B2	8/2020 Bartel et al.	2019/0150558 A1	5/2019	Shorten
10,743,607 B2	8/2020 Amis et al.	2019/0150563 A1	5/2019	Shorten
10,750,817 B2	8/2020 Barnes et al.	2019/0159547 A1	5/2019	Nakatsuka
10,758,001 B2	9/2020 Case et al.	2019/0216169 A1	7/2019	Yahata
D912,947 S	3/2021 Boys	2019/0246738 A1	8/2019	Connell et al.
D912,948 S	3/2021 Boys	2019/0283355 A1	9/2019	Bartel et al.
D913,655 S	3/2021 Boys	2019/0289961 A1	9/2019	Iuchi et al.
D913,663 S *	3/2021 Essilfie-Taylor D2/947	2019/0320759 A1	10/2019	Conrad et al.
D913,668 S	3/2021 Boys	2019/0365030 A1	12/2019	Chambers et al.
D917,848 S	5/2021 Wehrmeyer	2019/0365033 A1	12/2019	Chambers et al.
D922,741 S	6/2021 Boys	2019/0365034 A1	12/2019	Connell et al.
D922,742 S	6/2021 Boys	2019/0373982 A1	12/2019	Dupre et al.
D929,097 S	8/2021 Winskowicz	2020/0008519 A1	1/2020	Farris et al.
D938,145 S	12/2021 Rezap	2020/0046068 A1	2/2020	Choi et al.
D940,443 S	1/2022 Papp	2020/0100564 A1	4/2020	Bunnell et al.
D948,853 S	4/2022 Jenkins	2020/0121021 A1	4/2020	Bartel et al.
D950,211 S	5/2022 Tejada Bernard	2020/0281322 A1	9/2020	Caldwell et al.
D954,417 S *	6/2022 Bidal D2/954	2020/0307134 A1*	10/2020	Yoshida A43B 13/04
D964,717 S *	9/2022 Mahoney D2/947			
D973,337 S *	12/2022 Lesecq D2/962			
D976,564 S	1/2023 Klug	2021/0015209 A1	1/2021	Buck
D978,508 S	2/2023 Schneider	2021/0030112 A1	2/2021	Amoako et al.
2002/0174567 A1	11/2002 Krafsur et al.	2021/0052037 A1	2/2021	Greenspan
2003/0208929 A1	11/2003 Lucas et al.	2021/0085024 A1	3/2021	Chen

US D1,022,421 S

Page 4

(56)

References Cited

U.S. PATENT DOCUMENTS

2021/0368916 A1 12/2021 Wakasugi
 2022/0015505 A1* 1/2022 Constantinou A43B 5/02

FOREIGN PATENT DOCUMENTS

CA 70821 S 6/1992
 CA 79616 S 12/1996
 CA 80237 S 3/1997
 CA 80238 S 3/1997
 CA 97079 S 5/2002
 CA 97944 S 6/2003
 CA 142281 S 4/2012
 CA 145865 S 2/2013
 CA 147979 S 12/2013
 CA 148731 S 1/2014
 CA 150008 S 1/2014
 CA 151213 S 3/2014
 CA 151413 S 4/2014
 CA 151425 S 4/2014
 CA 151434 S 4/2014
 CA 155362 S 10/2014
 CA 155411 S 11/2014
 CA 155435 S 3/2015
 CA 155436 S 3/2015
 CA 159823 S 7/2015
 CA 165390 S 6/2016
 CA 169350 S 7/2017
 CA 169349 S 1/2018
 CN 2904704 Y 5/2007
 CN 302004098 * 3/2012
 CN 302004098 7/2012
 CN 204132549 U 2/2015
 CN 204467084 U 7/2015
 DE 4015138 A1 11/1991
 DE 102012104264 A1 11/2013
 DE 102018122753 A1 3/2019
 DE 102019107402 A1 9/2019
 EP 1483981 A1 12/2004
 EP 1346655 B1 8/2006
 EP 1525284 B1 6/2007
 EP 2138063 A1 12/2009
 EP 2689681 A1 1/2014
 EP 2491807 B1 10/2014
 EP 1847193 B1 1/2015
 EP 1386553 B1 6/2015
 EP 2269478 B1 9/2015
 EP 1690460 B1 8/2016
 EP 1894484 B1 3/2018
 EP 2979567 B1 10/2018

EP 3399882 A1 11/2018
 EP 2911542 B1 12/2018
 EP 3422893 A1 1/2019
 EP 3434132 A1 1/2019
 EP 3174419 B1 7/2019
 EP 3574791 A1 12/2019
 EP 2938218 B1 3/2020
 EP 3331393 B1 4/2020
 EP 3316721 B1 5/2020
 EP 3457882 B1 6/2020
 EP 3355738 B1 8/2020
 EP 3689171 A1 8/2020
 EP 3771358 A1 2/2021
 FR 2827126 A1 1/2003
 FR 2932963 B1 8/2010
 FR 2993758 B1 3/2015
 GB 2376408 A 12/2002
 JP D1732464 * 12/2022
 KR 100844183 B1 7/2008
 TW D145320 2/2012
 TW D154740 7/2013
 VN 30025397 12/2017
 VN 30025398 12/2017
 VN 30025399 12/2017
 WO 9842221 A1 10/1998
 WO 2000074515 A1 12/2000
 WO 2007113595 A2 10/2007
 WO 2008125716 A1 10/2008
 WO 2011020798 A1 2/2011
 WO 2013023163 A1 2/2013
 WO 2016094714 A1 6/2016
 WO 2017023532 A1 2/2017
 WO 2017120006 A1 7/2017
 WO 2017151501 A1 9/2017
 WO 2019157244 A1 8/2019
 WO 2021016163 A1 1/2021

OTHER PUBLICATIONS

[Puma EvoSpeed Sprint 14], announced on YouTube on Jan. 5, 2023 [online], [site visited May 5, 2023], Available from the internet URL: Puma evoSpeed Sprint 14 SKU: 9787857 (Year: 2023).*
 International Search Report of International Application No. PCT/IB2021/062487, dated Mar. 30, 2022, 7 pages.
 Written Opinion of International Application No. PCT/IB2021/062487, dated Mar. 30, 2022, 7 pages.
 [Adidas Adizero], available on Amazon.com, Nov. 23, 2015 [online], [May 5, 2023], Available from the internet URL: [https:// www.amazon.com/adidas-Adizero-Prime-Collegiate-White/dp/BO119E37WS/ref=cm_cr_arp_d_product_topie=UTF8](https://www.amazon.com/adidas-Adizero-Prime-Collegiate-White/dp/BO119E37WS/ref=cm_cr_arp_d_product_topie=UTF8) (Year: 2015).

* cited by examiner

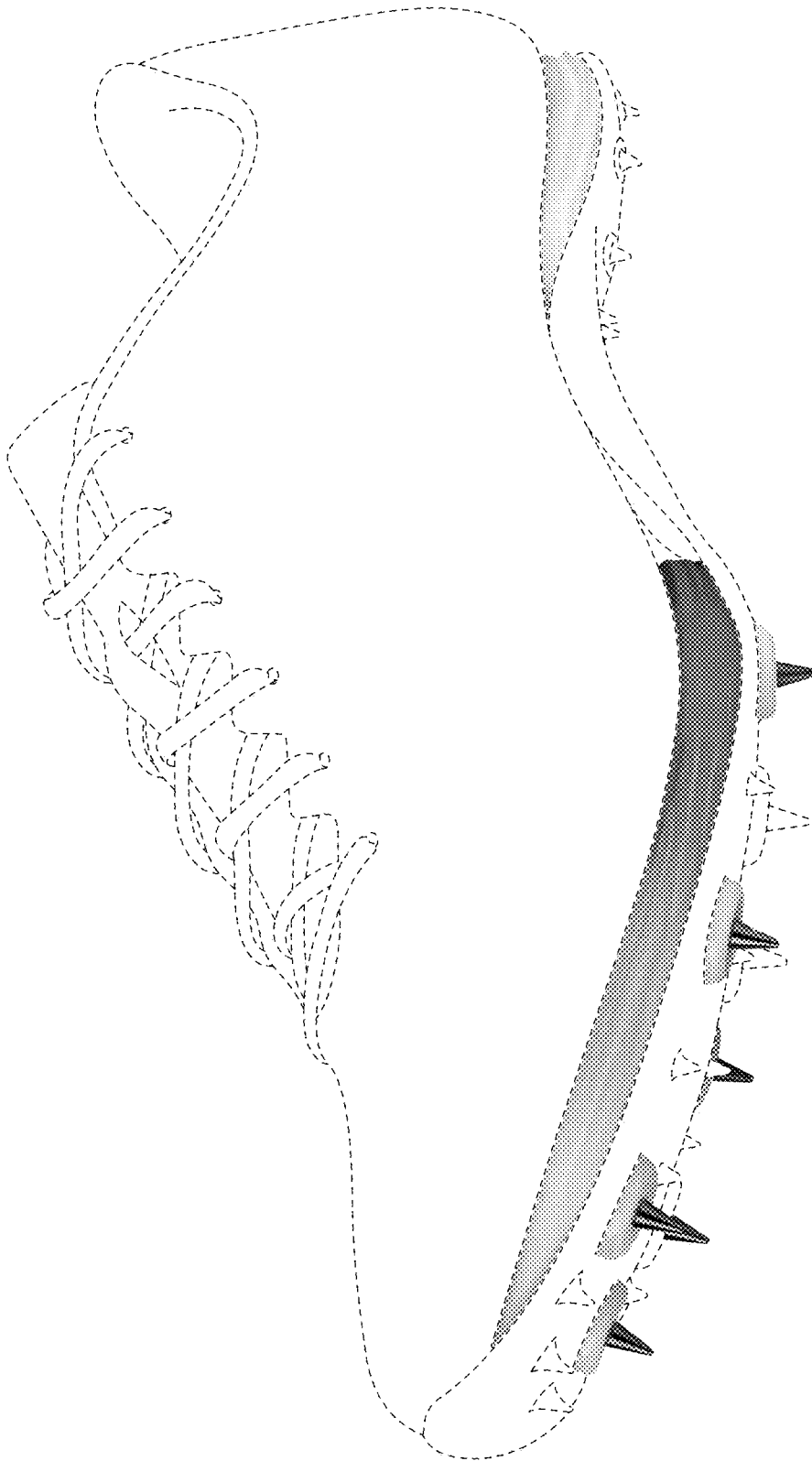

FIG. 1

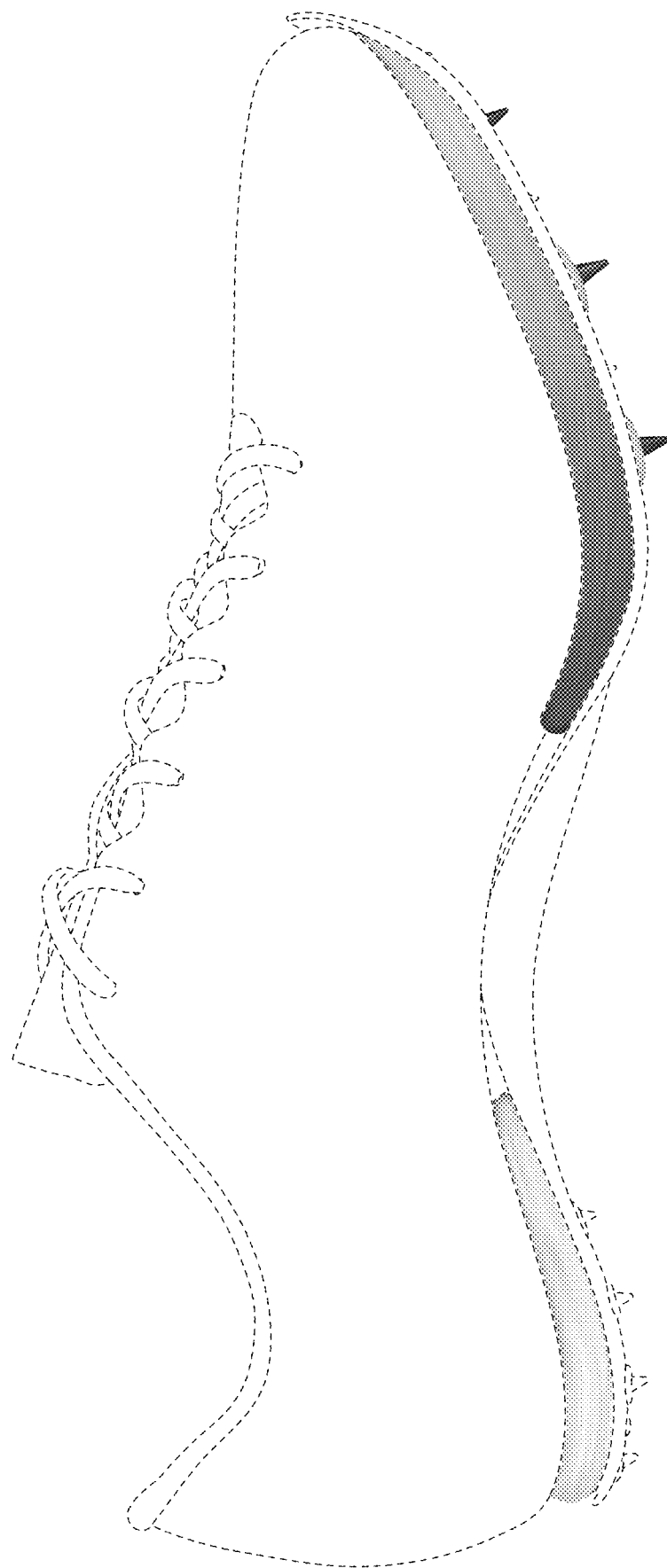

FIG. 2

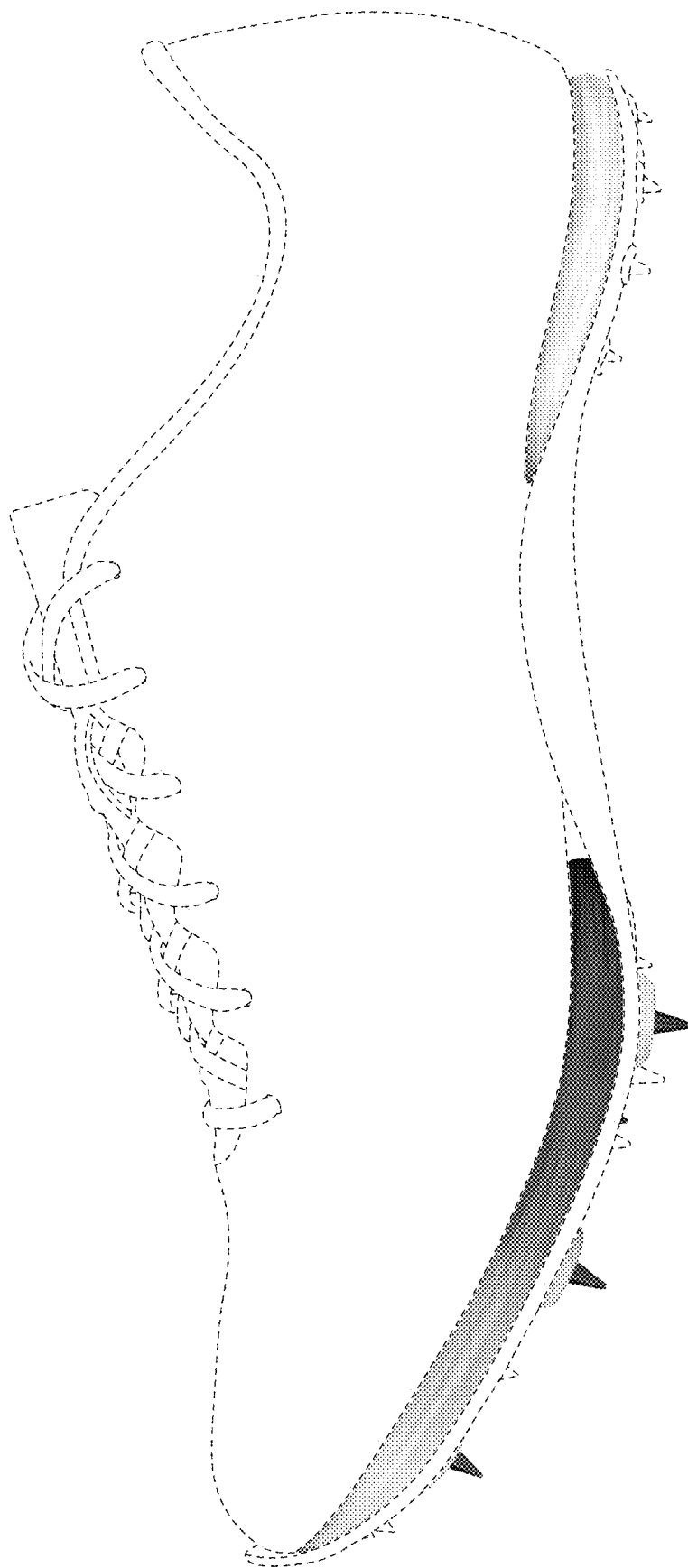

FIG. 3

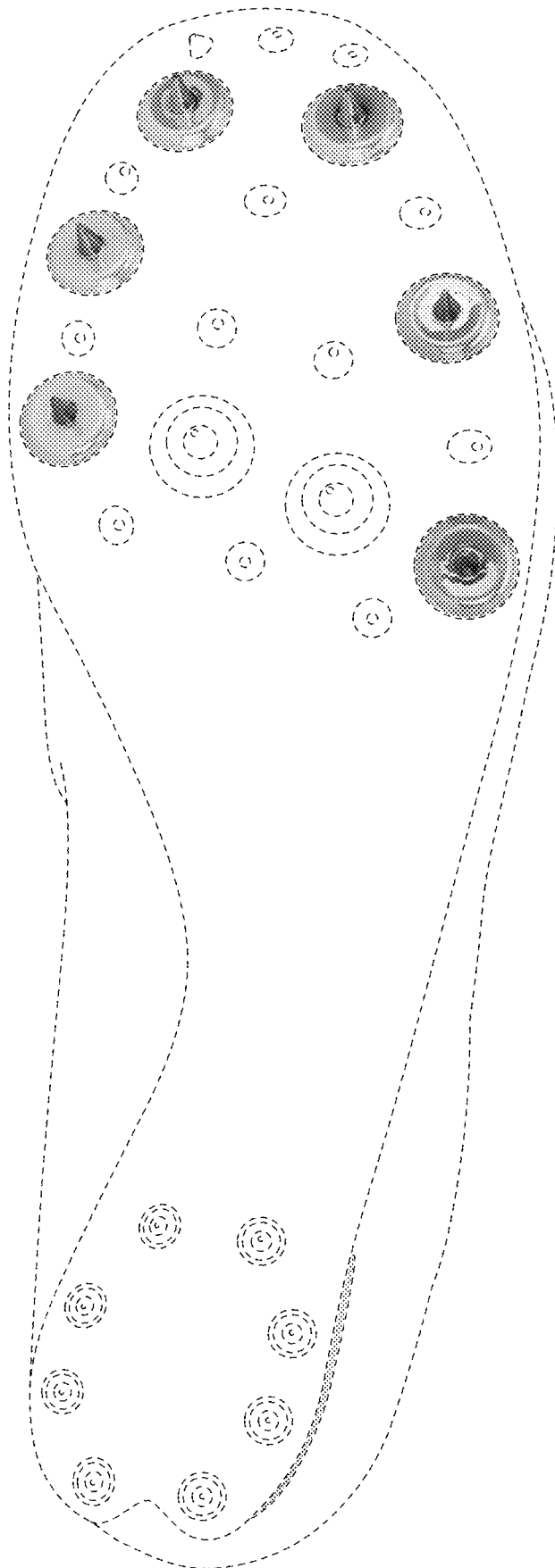

FIG. 4

EXHIBIT F



US0D1022422S

(12) **United States Design Patent** (10) **Patent No.:** **US D1,022,422 S**
Redon (45) **Date of Patent:** **** Apr. 16, 2024**

- (54) **SHOE**
- (71) Applicant: **PUMA SE**, Herzogenaurach (DE)
- (72) Inventor: **Arnaud Redon**, Nuremberg (DE)
- (73) Assignee: **PUMA SE**, Herzogenaurach (DE)
- (**) Term: **15 Years**
- (21) Appl. No.: **29/891,198**
- (22) Filed: **May 2, 2023**

- 2,578,591 A 12/1951 Phillips
- D208,393 S 8/1967 Onitsuka
- 3,402,484 A 9/1968 Brutting
- D232,200 S 7/1974 Inohara
- 4,020,569 A 5/1977 Fukuoka
- (Continued)

FOREIGN PATENT DOCUMENTS

- CA 38477 S 12/1974
- CA 70286 S 3/1992
- (Continued)

OTHER PUBLICATIONS

[Adidas Adizero], available on Amazon.com, Nov. 23, 2015 [online], [May 5, 2023]. Available from the internet URL: https://www.amazon.com/adidas-Adizero-Prime-Collegiate-White/dp/B0119E37WS/ref=cm_cr_ar_p_d_product_top?ie=UTF8 (Year: 2015).*

(Continued)

Primary Examiner — Jennifer L Rempfer
Assistant Examiner — Adrienne Corna
 (74) *Attorney, Agent, or Firm* — Quarles & Brady LLP

CLAIM

(57) The ornamental design for a shoe, as shown and described.

DESCRIPTION

FIG. 1 is a top, right, and front perspective view of an ornamental design for a shoe;
 FIG. 2 is a left side elevational view of the shoe of FIG. 1; and,
 FIG. 3 is a right side elevational view of the shoe of FIG. 1. The dash-dot-dash lines are included for the purpose of illustrating boundary lines and form no part of the claimed design. The dash-dash-dash lines are included for the purpose of illustrating portions of the shoe that form no part of the claimed design.

1 Claim, 3 Drawing Sheets

Related U.S. Application Data

- (63) Continuation of application No. 29/797,495, filed on Jun. 30, 2021.
- (51) **LOC (14) Cl.** **02-04**
- (52) **U.S. Cl.**
 USPC **D2/947**
- (58) **Field of Classification Search**
 USPC D2/902, 906, 908, 916, 918, 925,
 D2/946-962, 972, 977
 CPC A43B 13/00; A43B 13/02; A43B 13/023;
 A43B 13/026; A43B 13/04; A43B 13/08;
 A43B 13/10; A43B 13/12; A43B 13/14;
 A43B 13/20; A43B 13/24; A43B 13/28;
 A43B 13/30; A43B 13/32; A43B 13/34;
 A43B 13/36; A43B 13/181; A43B
 13/187; A43B 13/189; A43B 13/223
 See application file for complete search history.

References Cited

U.S. PATENT DOCUMENTS

- 324,065 A 8/1885 Andrews
- 413,693 A 10/1889 Walker
- 634,588 A 10/1899 Roche
- 1,088,328 A 2/1914 Cucinotta et al.
- 1,827,514 A 10/1931 Golden
- D158,403 S 5/1950 Pierce



US D1,022,422 S

Page 2

(56)		References Cited			
U.S. PATENT DOCUMENTS					
4,241,523	A	12/1980	Daswick	8,122,615	B2 2/2012 Lucas et al.
4,348,821	A	9/1982	Daswick	D666,795	S 9/2012 Shaffer
4,392,312	A	7/1983	Crowley	D672,123	S 12/2012 Williams, Jr.
4,463,505	A	8/1984	Duclos	8,341,856	B2 1/2013 Smith et al.
4,492,046	A	1/1985	Kosova	8,393,028	B2 3/2013 Namkook et al.
4,510,700	A	4/1985	Brown	D680,308	S 4/2013 Hardman
4,542,598	A	9/1985	Misevich et al.	8,418,379	B2 4/2013 Nishiwaki et al.
4,910,884	A	3/1990	Lindh et al.	D685,166	S 7/2013 Hatfield
5,024,007	A	6/1991	DuFour	D688,037	S * 8/2013 Dekovic D2/962
5,052,130	A	10/1991	Barry et al.	D690,088	S 9/2013 Hardman
D327,165	S	6/1992	Hatfield	D692,217	S 10/2013 Fogg
5,138,776	A	8/1992	Levin	8,567,094	B2 10/2013 Lubart
5,191,727	A	3/1993	Barry et al.	D694,498	S 12/2013 Carboy
5,203,095	A	4/1993	Allen	D694,499	S 12/2013 Williams, Jr.
D341,480	S	11/1993	Saito	8,613,149	B2 12/2013 Schwirian
5,339,544	A *	8/1994	Caberlotto A43B 23/0255 36/43	8,615,901	B2 12/2013 Caine et al.
D350,638	S	9/1994	Yoshikawa	D707,428	S * 6/2014 Seamarks D2/947
5,353,523	A	10/1994	Kilgore et al.	8,776,397	B2 7/2014 Borel et al.
5,435,079	A	7/1995	Gallegos	D710,579	S 8/2014 Williams, Jr.
5,461,800	A	10/1995	Uthi et al.	D713,625	S 9/2014 Raasch
5,528,842	A	6/1996	Ricci et al.	D713,626	S 9/2014 Raasch
D377,411	S	1/1997	Murray	D714,035	S 9/2014 O'Connor
5,592,757	A	1/1997	Jackinsky	8,850,718	B2 10/2014 Lubart
D378,472	S	3/1997	Bramani	8,919,015	B2 12/2014 Holt et al.
5,706,589	A	1/1998	Marc	8,945,449	B2 2/2015 Atwal et al.
D396,139	S	7/1998	Dietrich	8,978,274	B2 3/2015 Auger et al.
5,806,209	A	9/1998	Crowley et al.	8,984,775	B2 3/2015 Dombrow et al.
D401,741	S	12/1998	Clarke	9,009,988	B2 4/2015 Jacobs et al.
5,875,567	A	3/1999	Bayley	D731,767	S 6/2015 Lan
D415,607	S	10/1999	Merceron	9,066,559	B2 6/2015 Butler
6,029,374	A	2/2000	Herr et al.	9,144,265	B2 9/2015 Lubart
D423,201	S	4/2000	Wilson	9,167,864	B1 10/2015 Piontkowski et al.
D454,426	S	3/2002	Wilson	D743,153	S 11/2015 Taylor
6,502,330	B1	1/2003	David et al.	9,179,733	B2 11/2015 Peyton et al.
6,505,421	B1	1/2003	Vaz	9,204,686	B2 12/2015 Baum et al.
D473,042	S	4/2003	Wilson	9,210,967	B2 12/2015 Gerber
D473,047	S	4/2003	Wilson	D746,560	S 1/2016 Verfl
D476,800	S	7/2003	Fuerst	D747,083	S 1/2016 Verfl
6,775,930	B2	8/2004	Fuerst	9,241,533	B2 1/2016 Heard et al.
D498,901	S	11/2004	Hawker	9,259,050	B2 2/2016 Smith et al.
6,826,852	B2	12/2004	Fusco	D756,620	S 5/2016 Boys
6,857,205	B1	2/2005	Fusco et al.	9,326,562	B2 5/2016 Weidl et al.
D507,398	S	7/2005	Recchi	9,339,079	B2 5/2016 Lucas et al.
6,944,972	B2	9/2005	Schmid	9,375,048	B2 6/2016 James et al.
D511,617	S	11/2005	Matis	D768,969	S 10/2016 Boys
7,013,582	B2	3/2006	Lucas et al.	D770,739	S 11/2016 Nethongkome
7,016,867	B2	3/2006	Lyden	D770,740	S 11/2016 Teteriatnikov
7,096,605	B1	8/2006	Kozo et al.	9,491,983	B2 11/2016 Rushbrook
7,100,308	B2	9/2006	Aveni	9,516,916	B2 12/2016 Derrier
7,100,309	B2	9/2006	Smith et al.	9,549,589	B2 1/2017 Auger et al.
7,107,235	B2	9/2006	Lyden	D779,175	S 2/2017 Greenhalgh
7,152,343	B2	12/2006	Whatley	9,572,394	B2 2/2017 Heard et al.
7,219,447	B2	5/2007	LeVert	9,572,398	B2 2/2017 Hurd et al.
7,350,320	B2	4/2008	Chandler et al.	D782,790	S 4/2017 Lee
7,401,419	B2	7/2008	Lucas et al.	9,615,625	B1 4/2017 Huard et al.
7,401,422	B1	7/2008	Scholz et al.	9,661,896	B2 5/2017 Elliott et al.
7,434,337	B2	10/2008	Gibert et al.	D789,054	S 6/2017 Shyllon
7,484,317	B2	2/2009	Kita et al.	D790,169	S 6/2017 da Costa Pereira Machado
7,513,065	B2	4/2009	Kita et al.	D790,183	S 6/2017 VanHook
7,624,515	B2	12/2009	Kita et al.	9,668,540	B2 6/2017 Scofield et al.
7,644,518	B2	1/2010	Chandler et al.	D791,453	S 7/2017 McMillan
D615,738	S	5/2010	Teteriatnikov	D793,046	S 8/2017 Lee
7,707,743	B2	5/2010	Schindler et al.	D795,541	S 8/2017 Henrichot
7,786,193	B2	8/2010	Wilding et al.	D796,168	S 9/2017 Shyllon
7,832,117	B2	11/2010	Auger et al.	D796,799	S 9/2017 Shyllon
7,886,461	B2	2/2011	Sato	9,750,306	B2 9/2017 Baum et al.
7,900,376	B2	3/2011	Rabushka	D798,551	S 10/2017 Shyllon
D637,803	S	5/2011	Alvear	D798,554	S 10/2017 Swierszczk
7,950,091	B2	5/2011	Auger et al.	D798,555	S 10/2017 Enayah
7,987,618	B2	8/2011	Nishiwaki et al.	D798,558	S 10/2017 Pauk
8,028,442	B2	10/2011	Hodgson	9,775,404	B2 10/2017 Lyden
8,074,377	B2	12/2011	Nishiwaki et al.	9,820,528	B2 11/2017 Reinhardt et al.
8,079,160	B2	12/2011	Baucom et al.	9,820,529	B2 11/2017 Droege et al.
8,112,909	B2	2/2012	Kubo et al.	D810,411	S 2/2018 Klein
				9,883,714	B2 2/2018 Cavaliere et al.
				9,894,958	B2 2/2018 Cheney et al.
				D812,871	S 3/2018 Reyes
				D815,816	S 4/2018 Cin
				D815,817	S 4/2018 Cin

US D1,022,422 S

Page 3

(56)	References Cited	2004/0107601 A1	6/2004	Schmid	
	U.S. PATENT DOCUMENTS	2004/0200097 A1*	10/2004	Boyd	A43B 5/02 36/74
		2005/0102858 A1	5/2005	Yen	
D815,818 S	4/2018 Cin	2005/0126039 A1	6/2005	LeVert	
D815,820 S	4/2018 Cin	2005/0166422 A1	8/2005	Schaeffer et al.	
D815,821 S	4/2018 Cin	2005/0262739 A1	12/2005	McDonald	
D815,822 S	4/2018 Cin	2006/0196084 A1*	9/2006	Kos	A43B 1/0081 36/133
D815,823 S	4/2018 Cin				
9,930,934 B2	4/2018 Cook et al.	2007/0043630 A1	2/2007	Lyden	
D816,310 S	5/2018 Cooper	2007/0101617 A1	5/2007	Brewer et al.	
D816,311 S	5/2018 Cin	2007/0240331 A1	10/2007	Borel	
D816,959 S	5/2018 Cin	2007/0266593 A1	11/2007	Schindler et al.	
D816,960 S	5/2018 Cin	2007/0271818 A1	11/2007	Rabushka	
D817,614 S	5/2018 Cin	2008/0072462 A1	3/2008	Fusco	
D817,615 S	5/2018 Cin	2008/0189982 A1	8/2008	Krafsur	
D817,616 S	5/2018 Cin	2009/0100718 A1*	4/2009	Gerber	A43C 15/04 36/67 A
9,961,959 B2	5/2018 Gerber				
9,968,157 B2	5/2018 Wardlaw et al.				
9,968,160 B2	5/2018 Peyton	2009/0183393 A1	7/2009	Lee	
10,010,135 B2	7/2018 Lovell et al.	2009/0307925 A1	12/2009	Pfister	
10,010,137 B2	7/2018 Foxen	2010/0175280 A1	7/2010	Rinehart, Jr.	
10,016,919 B2	7/2018 Cook et al.	2010/0186261 A1	7/2010	Baker	
10,111,491 B2	10/2018 Tanabe et al.	2010/0218397 A1	9/2010	Nishiwaki et al.	
10,159,303 B2	12/2018 Wang et al.	2010/0263228 A1	10/2010	Kang	
10,165,821 B2	1/2019 Truelsen	2011/0138652 A1	6/2011	Lucas	
10,165,824 B2	1/2019 Auger et al.	2012/0317835 A1	12/2012	Raysse et al.	
10,226,097 B2	3/2019 Farris et al.	2013/0192090 A1	8/2013	Smith	
10,231,517 B2	3/2019 Baucom et al.	2014/0068966 A1	3/2014	Chaffin	
10,271,614 B2	4/2019 Huard et al.	2014/0101972 A1	4/2014	Ha	
D847,478 S	5/2019 Fracassi	2014/0230280 A1	8/2014	Heard et al.	
10,299,535 B2	5/2019 Hurd et al.	2014/0230283 A1*	8/2014	Cordova	A43B 5/185 36/103
10,314,365 B2	6/2019 James et al.				
10,314,367 B2	6/2019 Kilgore et al.				
D853,097 S	7/2019 Cass	2014/0237852 A1	8/2014	Oberschneider et al.	
D853,701 S	7/2019 Hong	2014/0245640 A1	9/2014	Heard et al.	
10,349,700 B2	7/2019 Amis et al.	2015/0047224 A1	2/2015	Zhao et al.	
D855,301 S	8/2019 Williams, Jr.	2015/0107132 A1	4/2015	Takeshita	
D862,046 S	10/2019 Page	2016/0262492 A1	9/2016	Fujita	
10,433,616 B2	10/2019 Takeshita et al.	2017/0079376 A1	3/2017	Bunnell et al.	
10,441,027 B2	10/2019 Bartel et al.	2017/0105477 A1	4/2017	Wilkerson	
10,448,701 B2	10/2019 Farris et al.	2017/0150779 A1	6/2017	Walker et al.	
10,448,704 B2	10/2019 Dupre et al.	2017/0245590 A1	8/2017	Kohatsu et al.	
D870,429 S	12/2019 Becker	2018/0027922 A1	2/2018	Orand	
10,512,301 B2	12/2019 Peyton	2018/0035752 A1	2/2018	Walker et al.	
10,517,350 B2	12/2019 Orand et al.	2018/0042338 A1	2/2018	Orand	
10,517,351 B2	12/2019 Arciuolo	2018/0153254 A1	6/2018	Fusco et al.	
10,524,536 B2	1/2020 Bunnell et al.	2018/0168281 A1	6/2018	Case et al.	
10,548,368 B2	2/2020 Bartel et al.	2018/0199666 A1	7/2018	Moriyasu et al.	
10,595,587 B2	3/2020 Cook et al.	2018/0199675 A1	7/2018	Cook et al.	
D882,918 S	5/2020 Kosenick	2018/0235310 A1	8/2018	Wardlaw et al.	
10,653,205 B2	5/2020 Orand	2018/0271215 A1	9/2018	Foxen	
D885,718 S	6/2020 Roulo	2018/0338568 A1	11/2018	Chambers et al.	
D889,798 S	7/2020 Vella	2018/0352902 A1	12/2018	Wardle	
10,743,606 B2	8/2020 Bartel et al.	2019/0082781 A1	3/2019	Iuchi et al.	
10,743,607 B2	8/2020 Amis et al.	2019/0150558 A1	5/2019	Shorten	
10,750,817 B2	8/2020 Barnes et al.	2019/0150563 A1	5/2019	Shorten	
10,758,001 B2	9/2020 Case et al.	2019/0159547 A1	5/2019	Nakatsuka	
D912,947 S	3/2021 Boys	2019/0216169 A1	7/2019	Yahata	
D912,948 S	3/2021 Boys	2019/0246738 A1	8/2019	Connell et al.	
D913,655 S	3/2021 Boys	2019/0283355 A1	9/2019	Bartel et al.	
D913,663 S *	3/2021 Essilfie-Taylor	2019/0289961 A1	9/2019	Iuchi et al.	
D913,668 S	3/2021 Boys	2019/0320759 A1	10/2019	Conrad et al.	
D917,848 S	5/2021 Wehrmeyer	2019/0365030 A1	12/2019	Chambers et al.	
D922,741 S	6/2021 Boys	2019/0365033 A1	12/2019	Chambers et al.	
D922,742 S	6/2021 Boys	2019/0365034 A1	12/2019	Connell et al.	
D929,097 S	8/2021 Winskowicz	2019/0373982 A1	12/2019	Dupre et al.	
D938,145 S	12/2021 Rezab	2020/0008519 A1	1/2020	Farris et al.	
D940,443 S	1/2022 Papp	2020/0046068 A1	2/2020	Choi et al.	
D948,853 S	4/2022 Jenkins	2020/0100564 A1	4/2020	Bunnell et al.	
D950,211 S	5/2022 Tejada Bernard	2020/0121021 A1	4/2020	Bartel et al.	
D954,417 S *	6/2022 Bidal	2020/0281322 A1	9/2020	Caldwell et al.	
D964,717 S *	9/2022 Mahoney	2020/0307134 A1*	10/2020	Yoshida	A43B 13/04
D973,337 S *	12/2022 Lesecq	2021/0015209 A1	1/2021	Buck	
D976,564 S	1/2023 Klug	2021/0030112 A1	2/2021	Amoako et al.	
D978,508 S	2/2023 Schneider	2021/0052037 A1	2/2021	Greenspan	
2002/0174567 A1	11/2002 Krafsur et al.	2021/0085024 A1	3/2021	Chen	
2003/0208929 A1	11/2003 Lucas et al.				
2003/0233770 A1	12/2003 Foscaro				

US D1,022,422 S

Page 4

(56)

References Cited

U.S. PATENT DOCUMENTS

2021/0368916 A1 12/2021 Wakasugi
 2022/0015505 A1* 1/2022 Constantinou A43B 5/02

FOREIGN PATENT DOCUMENTS

CA 70821 S 6/1992
 CA 79616 S 12/1996
 CA 80237 S 3/1997
 CA 80238 S 3/1997
 CA 97079 S 5/2002
 CA 97944 S 6/2003
 CA 142281 S 4/2012
 CA 145865 S 2/2013
 CA 147979 S 12/2013
 CA 148731 S 1/2014
 CA 150008 S 1/2014
 CA 151213 S 3/2014
 CA 151413 S 4/2014
 CA 151425 S 4/2014
 CA 151434 S 4/2014
 CA 155362 S 10/2014
 CA 155411 S 11/2014
 CA 155435 S 3/2015
 CA 155436 S 3/2015
 CA 159823 S 7/2015
 CA 165390 S 6/2016
 CA 169350 S 7/2017
 CA 169349 S 1/2018
 CN 2904704 Y 5/2007
 CN 302004098 * 3/2012
 CN 302004098 7/2012
 CN 204132549 U 2/2015
 CN 204467084 U 7/2015
 DE 4015138 A1 11/1991
 DE 102012104264 A1 11/2013
 DE 102018122753 A1 3/2019
 DE 102019107402 A1 9/2019
 EP 1483981 A1 12/2004
 EP 1346655 B1 8/2006
 EP 1525284 B1 6/2007
 EP 2138063 A1 12/2009
 EP 2689681 A1 1/2014
 EP 2491807 B1 10/2014
 EP 1847193 B1 1/2015
 EP 1386553 B1 6/2015
 EP 2269478 B1 9/2015
 EP 1690460 B1 8/2016
 EP 1894484 B1 3/2018
 EP 2979567 B1 10/2018

EP 3399882 A1 11/2018
 EP 2911542 B1 12/2018
 EP 3422893 A1 1/2019
 EP 3434132 A1 1/2019
 EP 3174419 B1 7/2019
 EP 3574791 A1 12/2019
 EP 2938218 B1 3/2020
 EP 3331393 B1 4/2020
 EP 3316721 B1 5/2020
 EP 3457882 B1 6/2020
 EP 3355738 B1 8/2020
 EP 3689171 A1 8/2020
 EP 3771358 A1 2/2021
 FR 2827126 A1 1/2003
 FR 2932963 B1 8/2010
 FR 2993758 B1 3/2015
 GB 2376408 A 12/2002
 JP D1732464 * 12/2022
 KR 100844183 B1 7/2008
 TW D145320 2/2012
 TW D154740 7/2013
 VN 30025397 12/2017
 VN 30025398 12/2017
 VN 30025399 12/2017
 WO 9842221 A1 10/1998
 WO 2000074515 A1 12/2000
 WO 2007113595 A2 10/2007
 WO 2008125716 A1 10/2008
 WO 2011020798 A1 2/2011
 WO 2013023163 A1 2/2013
 WO 2016094714 A1 6/2016
 WO 2017023532 A1 2/2017
 WO 2017120006 A1 7/2017
 WO 2017151501 A1 9/2017
 WO 2019157244 A1 8/2019
 WO 2021016163 A1 1/2021

OTHER PUBLICATIONS

[Puma EvoSpeed Sprint 14], announced on YouTube on Jan. 5, 2023 [online], [site visited May 5, 2023], Available from the internet URL: Puma evoSpeed Sprint 14 SKU: 9787857 (Year: 2023).*
 International Search Report of International Application No. PCT/IB2021/062487, dated Mar. 30, 2022, 7 pages.
 Written Opinion of International Application No. PCT/IB2021/062487, dated Mar. 30, 2022, 7 pages.
 [Adidas Adizero], available on Amazon.com, Nov. 23, 2015 [online], [May 5, 2023], Available from the internet URL: [https:// www.amazon.com/adidas-Adizero-Prime-Collegiate-White/dp/BO119E37WS/ref=cm_cr_ar_p_d_product_topie=UTFS](https://www.amazon.com/adidas-Adizero-Prime-Collegiate-White/dp/BO119E37WS/ref=cm_cr_ar_p_d_product_topie=UTFS) (Year: 2015).

* cited by examiner



FIG. 1



FIG. 2

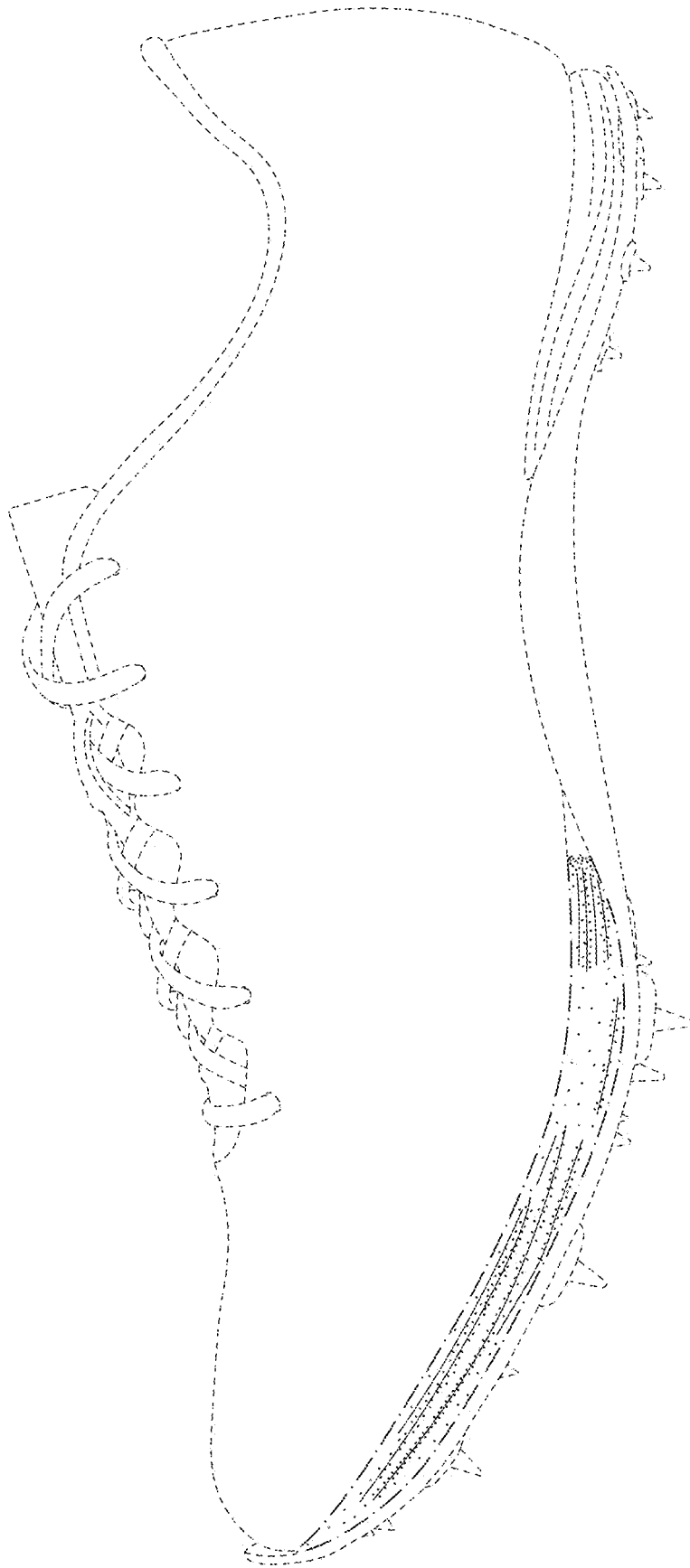

FIG. 3

EXHIBIT G



US0D1023531S

(12) **United States Design Patent** (10) **Patent No.:** **US D1,023,531 S**
Redon (45) **Date of Patent:** **** Apr. 23, 2024**

(54) **SHOE**
 (71) Applicant: **PUMA SE**, Herzogenaurach (DE)
 (72) Inventor: **Arnaud Redon**, Nuremberg (DE)
 (73) Assignee: **PUMA SE**, Herzogenaurach (DE)
 (**) Term: **15 Years**
 (21) Appl. No.: **29/891,911**
 (22) Filed: **May 11, 2023**

Related U.S. Application Data

(63) Continuation of application No. 29/891,198, filed on May 2, 2023, and a continuation of application No. 29/891,188, filed on May 2, 2023, which is a continuation of application No. 29/797,495, filed on Jun. 30, 2021, now Pat. No. Des. 1,010,297, said application No. 29/891,198 is a continuation of application No. 29/797,495, filed on Jun. 30, 2021, now Pat. No. Des. 1,010,297.

(51) **LOC (14) Cl.** **02-04**
 (52) **U.S. Cl.**
 USPC **D2/947; D2/962; D2/954; D2/959; D2/906**

(58) **Field of Classification Search**
 USPC D2/902, 906, 908, 916, 918, 925, D2/946-962, 972, 977
 CPC A43B 13/00; A43B 13/02; A43B 13/023; A43B 13/026; A43B 13/04; A43B 13/08; A43B 13/10; A43B 13/12; A43B 13/14; A43B 13/20; A43B 13/24; A43B 13/28; A43B 13/30; A43B 13/32; A43B 13/34; A43B 13/36; A43B 13/181; A43B 13/187; A43B 13/189; A43B 13/223
 See application file for complete search history.

(56) **References Cited**

U.S. PATENT DOCUMENTS

324,065 A 8/1885 Andrews
 413,693 A 10/1889 Walker

634,588 A	10/1899	Roche	
1,088,328 A	2/1914	Cucinotta et al.	
1,827,514 A	10/1931	Golden	
D158,403 S	5/1950	Pierce	
2,578,591 A	12/1951	Phillips	
D208,393 S	8/1967	Onitsuka	
3,402,484 A	9/1968	Brutting	
D232,200 S	7/1974	Masanobu	
4,020,569 A	5/1977	Fukuoka	
4,241,523 A	12/1980	Daswick	
4,348,821 A	9/1982	Daswick	
4,392,312 A	7/1983	Crowley	
4,463,505 A	8/1984	Duclos	
4,492,046 A	1/1985	Kosova	
4,510,700 A	4/1985	Brown	
4,542,598 A	9/1985	Misevich et al.	
4,910,884 A	3/1990	Lindh et al.	
5,024,007 A	6/1991	DuFour	
5,052,130 A	10/1991	Barry et al.	
D327,165 S	6/1992	Hatfield	
5,138,776 A	8/1992	Levin	
5,191,727 A	3/1993	Barry et al.	
5,203,095 A	4/1993	Allen	
D341,480 S	11/1993	Saito	
5,339,544 A *	8/1994	Caberlotto	A43B 23/0255 36/43
D350,638 S	9/1994	Yoshikawa	
5,353,523 A	10/1994	Kilgore et al.	
5,435,079 A	7/1995	Gallegos	
5,461,800 A	10/1995	Luthi et al.	
5,528,842 A	6/1996	Ricci et al.	
D377,411 S	1/1997	Murray	
5,592,757 A	1/1997	Jackinsky	
D378,472 S	3/1997	Bramani	
5,706,589 A	1/1998	Marc	
D396,139 S	7/1998	Dietrich	
5,806,209 A	9/1998	Crowley et al.	
D401,741 S	12/1998	Clarke	
5,875,567 A	3/1999	Bayley	
D415,607 S	10/1999	Merceron	
6,029,374 A	2/2000	Herr et al.	
D423,201 S	4/2000	Wilson	
D454,426 S	3/2002	Wilson	
6,502,330 B1	1/2003	David et al.	
6,505,421 B1	1/2003	Vaz	
D473,042 S	4/2003	Wilson	
D473,047 S	4/2003	Wilson	
D476,800 S	7/2003	Fuerst	
6,775,930 B2	8/2004	Fuerst	
D498,901 S	11/2004	Hawker	
6,826,852 B2	12/2004	Fusco	
6,857,205 B1	2/2005	Fusco et al.	
D507,398 S	7/2005	Recchi	

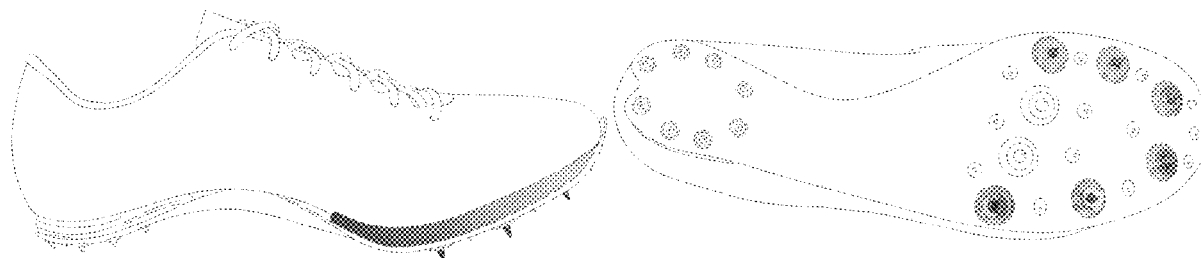

US D1,023,531 S

Page 2

6,944,972 B2	9/2005	Schmid	9,516,916 B2	12/2016	Derrier
D511,617 S	11/2005	Matis	9,549,589 B2	1/2017	Auger et al.
7,013,582 B2	3/2006	Lucas et al.	D779,175 S	2/2017	Greenhalgh
7,016,867 B2	3/2006	Lyden	9,572,394 B2	2/2017	Heard et al.
7,096,605 B1	8/2006	Kozo et al.	9,572,398 B2	2/2017	Hurd et al.
7,100,308 B2	9/2006	Aveni	D782,790 S	4/2017	Lee
7,100,309 B2	9/2006	Smith et al.	9,615,625 B1	4/2017	Huard et al.
7,107,235 B2	9/2006	Lyden	9,661,896 B2	5/2017	Elliott et al.
7,152,343 B2	12/2006	Whatley	D789,054 S	6/2017	Shyllon
7,219,447 B2	5/2007	LeVert	D790,169 S	6/2017	da Costa Pereira Machado
7,350,320 B2	4/2008	Chandler et al.	D790,183 S	6/2017	VanHook
7,401,419 B2	7/2008	Lucas et al.	9,668,540 B2	6/2017	Scotfield et al.
7,401,422 B1	7/2008	Scholz et al.	D791,453 S	7/2017	McMillan
7,434,337 B2	10/2008	Gibert et al.	D793,046 S	8/2017	Lee
7,484,317 B2	2/2009	Kita et al.	D795,541 S	8/2017	Henrichot
7,513,065 B2	4/2009	Kita et al.	D796,168 S	9/2017	Shyllon
7,624,515 B2	12/2009	Kita et al.	D796,799 S	9/2017	Shyllon
7,644,518 B2	1/2010	Chandler et al.	9,750,306 B2	9/2017	Baum et al.
D615,738 S	5/2010	Teteriatnikov	D798,551 S	10/2017	Shyllon
7,707,743 B2	5/2010	Schindler et al.	D798,554 S	10/2017	Swierszczk
7,786,193 B2	8/2010	Wilding et al.	D798,555 S	10/2017	Enayah
7,832,117 B2	11/2010	Auger et al.	D798,558 S	10/2017	Pauk
7,886,461 B2	2/2011	Sato	9,775,404 B2	10/2017	Lyden
7,900,376 B2	3/2011	Rabushka	9,820,528 B2	11/2017	Reinhardt et al.
D637,803 S	5/2011	Alvear	9,820,529 B2	11/2017	Droege et al.
7,950,091 B2	5/2011	Auger et al.	D810,411 S	2/2018	Klein
7,987,618 B2	8/2011	Nishiwaki et al.	9,883,714 B2	2/2018	Cavaliere et al.
8,028,442 B2	10/2011	Hodgson	9,894,958 B2	2/2018	Cheney et al.
8,074,377 B2	12/2011	Nishiwaki et al.	D812,871 S	3/2018	Reyes
8,079,160 B2	12/2011	Baucom et al.	D815,816 S	4/2018	Cin
8,112,909 B2	2/2012	Kubo et al.	D815,817 S	4/2018	Cin
8,122,615 B2	2/2012	Lucas et al.	D815,818 S	4/2018	Cin
D666,795 S	9/2012	Shaffer	D815,820 S	4/2018	Cin
D672,123 S	12/2012	Williams, Jr.	D815,821 S	4/2018	Cin
8,341,856 B2	1/2013	Smith et al.	D815,822 S	4/2018	Cin
8,393,028 B2	3/2013	Namkook et al.	D815,823 S	4/2018	Cin
D680,308 S	4/2013	Hardman	9,930,934 B2	4/2018	Cook et al.
8,418,379 B2	4/2013	Nishiwaki et al.	D816,310 S	5/2018	Cooper
D685,166 S	7/2013	Hatfield	D816,311 S	5/2018	Cin
D688,037 S *	8/2013	Dekovic D2/962	D816,959 S	5/2018	Cin
D690,088 S	9/2013	Hardman	D816,960 S	5/2018	Cin
D692,217 S	10/2013	Fogg	D817,614 S	5/2018	Cin
8,567,094 B2	10/2013	Lubart	D817,615 S	5/2018	Cin
D694,498 S	12/2013	Carboy	D817,616 S	5/2018	Cin
D694,499 S	12/2013	Williams, Jr.	9,961,959 B2	5/2018	Gerber
8,613,149 B2	12/2013	Schwirian	9,968,157 B2	5/2018	Wardlaw et al.
8,615,901 B2	12/2013	Caine et al.	9,968,160 B2	5/2018	Peyton
D707,428 S *	6/2014	Seamarks D2/947	10,010,135 B2	7/2018	Lovell et al.
8,776,397 B2	7/2014	Borel et al.	10,010,137 B2	7/2018	Foxen
D710,579 S	8/2014	Williams, Jr.	10,016,919 B2	7/2018	Cook et al.
D713,625 S	9/2014	Raasch	10,111,491 B2	10/2018	Tanabe et al.
D713,626 S	9/2014	Raasch	10,159,303 B2	12/2018	Wang et al.
D714,035 S	9/2014	O'Connor	10,165,821 B2	1/2019	Truelsen
8,850,718 B2	10/2014	Lubart	10,165,824 B2	1/2019	Auger et al.
8,919,015 B2	12/2014	Holt et al.	10,226,097 B2	3/2019	Farris et al.
8,945,449 B2	2/2015	Atwal et al.	10,231,517 B2	3/2019	Baucom et al.
8,978,274 B2	3/2015	Auger et al.	10,271,614 B2	4/2019	Huard et al.
8,984,775 B2	3/2015	Dombrow et al.	D847,478 S	5/2019	Fracassi
9,009,988 B2	4/2015	Jacobs et al.	10,299,535 B2	5/2019	Hurd et al.
D731,767 S	6/2015	Lan	10,314,365 B2	6/2019	James et al.
9,066,559 B2	6/2015	Butler	10,314,367 B2	6/2019	Kilgore et al.
9,144,265 B2	9/2015	Lubart	D853,097 S	7/2019	Cass
9,167,864 B1	10/2015	Piontkowski et al.	D853,701 S	7/2019	Hong
D743,153 S	11/2015	Taylor	10,349,700 B2	7/2019	Amis et al.
9,179,733 B2	11/2015	Peyton et al.	D855,301 S	8/2019	Williams, Jr.
9,204,686 B2	12/2015	Baum et al.	D862,046 S	10/2019	Page
9,210,967 B2	12/2015	Gerber	10,433,616 B2	10/2019	Takeshita et al.
D746,560 S	1/2016	Verfl	10,441,027 B2	10/2019	Bartel et al.
D747,083 S	1/2016	Verfl	10,448,701 B2	10/2019	Farris et al.
9,241,533 B2	1/2016	Heard et al.	10,448,704 B2	10/2019	Dupre et al.
9,259,050 B2	2/2016	Smith et al.	D870,429 S	12/2019	Becker
D756,620 S	5/2016	Boys	10,512,301 B2	12/2019	Peyton
9,326,562 B2	5/2016	Weidi et al.	10,517,350 B2	12/2019	Orand et al.
9,339,079 B2	5/2016	Lucas et al.	10,517,351 B2	12/2019	Arciuolo
9,375,048 B2	6/2016	James et al.	10,524,536 B2	1/2020	Bunnell et al.
D768,969 S	10/2016	Boys	10,548,368 B2	2/2020	Bartel et al.
D770,739 S	11/2016	Nethongkome	10,595,587 B2	3/2020	Cook et al.
D770,740 S	11/2016	Teteriatnikov	D882,918 S	5/2020	Kosenick
9,491,983 B2	11/2016	Rushbrook	10,653,205 B2	5/2020	Orand

US D1,023,531 S

Page 3

D885,718 S	6/2020	Roulo	2019/0082781 A1	3/2019	Iuchi et al.
D889,798 S	7/2020	Vella	2019/0150558 A1	5/2019	Shorten
10,743,606 B2	8/2020	Bartel et al.	2019/0150563 A1	5/2019	Shorten
10,743,607 B2	8/2020	Amis et al.	2019/0159547 A1	5/2019	Nakatsuka
10,750,817 B2	8/2020	Bames et al.	2019/0216169 A1	7/2019	Yahata
10,758,001 B2	9/2020	Case et al.	2019/0246738 A1	8/2019	Connell et al.
D912,947 S	3/2021	Boys	2019/0283355 A1	9/2019	Bartel et al.
D912,948 S	3/2021	Boys	2019/0289961 A1	9/2019	Iuchi et al.
D913,655 S	3/2021	Boys	2019/0320759 A1	10/2019	Conrad et al.
D913,663 S *	3/2021	Essilfie-Taylor D2/947	2019/0365030 A1	12/2019	Chambers et al.
D913,668 S	3/2021	Boys	2019/0365033 A1	12/2019	Chambers et al.
D917,848 S	5/2021	Wehrmeyer	2019/0365034 A1	12/2019	Connell et al.
D922,741 S	6/2021	Boys	2019/0373982 A1	12/2019	Dupre et al.
D922,742 S	6/2021	Boys	2020/0008519 A1	1/2020	Farris et al.
D929,097 S	8/2021	Winskowicz	2020/0046068 A1	2/2020	Choi et al.
D938,145 S	12/2021	Rezab	2020/0100564 A1	4/2020	Bunnell et al.
D940,443 S	1/2022	Papp	2020/0121021 A1	4/2020	Bartel et al.
D948,853 S	4/2022	Jenkins	2020/0281322 A1	9/2020	Caldwell et al.
D950,211 S	5/2022	Tejada Bernard	2020/0307134 A1 *	10/2020	Yoshida A43B 13/04
D954,417 S *	6/2022	Bidal D2/954	2021/0015209 A1	1/2021	Buck
D964,717 S *	9/2022	Mahoney D2/947	2021/0030112 A1	2/2021	Amoako et al.
D973,337 S *	12/2022	Lesecq D2/962	2021/0052037 A1	2/2021	Greenspan
D976,564 S	1/2023	Klug	2021/0085024 A1	3/2021	Chen
D978,508 S	2/2023	Schneider	2021/0368916 A1	12/2021	Wakasugi
2002/0174567 A1	11/2002	Krafsur et al.	2022/0015505 A1 *	1/2022	Constantinou A43B 5/02
2003/0208929 A1	11/2003	Lucas et al.			
2003/0233770 A1	12/2003	Foscaro			
2004/0107601 A1	6/2004	Schmid			
2004/0200097 A1 *	10/2004	Boyd A43B 5/02			
		36/74			
2005/0102858 A1	5/2005	Yen	CA	38477 S	12/1974
2005/0126039 A1	6/2005	LeVert	CA	70286 S	3/1992
2005/0166422 A1	8/2005	Schaeffer et al.	CA	70821 S	6/1992
2005/0262739 A1	12/2005	McDonald	CA	79616 S	12/1996
2006/0196084 A1 *	9/2006	Kos A43B 1/0081	CA	80237 S	3/1997
		36/133	CA	80238 S	3/1997
			CA	97079 S	5/2002
			CA	97944 S	6/2003
2007/0043630 A1	2/2007	Lyden	CA	142281 S	4/2012
2007/0101617 A1	5/2007	Brewer et al.	CA	145865 S	2/2013
2007/0240331 A1	10/2007	Borel	CA	147979 S	12/2013
2007/0266593 A1	11/2007	Schindler et al.	CA	148731 S	1/2014
2007/0271818 A1	11/2007	Rabushka	CA	150008 S	1/2014
2008/0072462 A1	3/2008	Fusco	CA	151213 S	3/2014
2008/0189982 A1	8/2008	Krafsur	CA	151413 S	4/2014
2009/0100718 A1 *	4/2009	Gerber A43C 15/04	CA	151425 S	4/2014
		36/67 A	CA	151434 S	4/2014
			CA	155362 S	10/2014
2009/0183393 A1	7/2009	Lee	CA	155411 S	11/2014
2009/0307925 A1	12/2009	Pfister	CA	155435 S	3/2015
2010/0175280 A1	7/2010	Rinehart, Jr.	CA	155436 S	3/2015
2010/0186261 A1	7/2010	Baker	CA	159823 S	7/2015
2010/0218397 A1	9/2010	Nishiwaki et al.	CA	165390 S	6/2016
2010/0263228 A1	10/2010	Kang	CA	169350 S	7/2017
2011/0138652 A1	6/2011	Lucas	CA	169349 S	1/2018
2012/0317835 A1	12/2012	Raysse et al.	CN	2904704 Y	5/2007
2013/0192090 A1	8/2013	Smith	CN	302004098 *	3/2012
2014/0068966 A1	3/2014	Chaffin	CN	302004098	7/2012
2014/0101972 A1	4/2014	Ha	CN	204132549 U	2/2015
2014/0230280 A1	8/2014	Heard et al.	CN	204467084 U	7/2015
2014/0230283 A1 *	8/2014	Cordova A43B 5/185	DE	4015138 A1	11/1991
		36/103	DE	102012104264 A1	11/2013
2014/0237852 A1	8/2014	Oberschneider et al.	DE	102018122753 A1	3/2019
2014/0245640 A1	9/2014	Heard et al.	DE	102019107402 A1	9/2019
2015/0047224 A1	2/2015	Zhao et al.	EP	1483981 A1	12/2004
2015/0107132 A1	4/2015	Takeshita	EP	1346655 B1	8/2006
2016/0262492 A1	9/2016	Fujita	EP	1525284 B1	6/2007
2017/0079376 A1	3/2017	Bunnell et al.	EP	2138063 A1	12/2009
2017/0105477 A1	4/2017	Wilkerson	EP	2689681 A1	1/2014
2017/0150779 A1	6/2017	Walker et al.	EP	2491807 B1	10/2014
2017/0245590 A1	8/2017	Kohatsu et al.	EP	1847193 B1	1/2015
2018/0027922 A1	2/2018	Orand	EP	1386553 B1	6/2015
2018/0035752 A1	2/2018	Walker et al.	EP	2269478 B1	9/2015
2018/0042338 A1	2/2018	Orand	EP	1690460 B1	8/2016
2018/0153254 A1	6/2018	Fusco et al.	EP	1894484 B1	3/2018
2018/0168281 A1	6/2018	Case et al.	EP	2979567 B1	10/2018
2018/0199666 A1	7/2018	Moriyasu et al.	EP	3399882 A1	11/2018
2018/0199675 A1	7/2018	Cook et al.	EP	2911542 B1	12/2018
2018/0235310 A1	8/2018	Wardlaw et al.	EP	3422893 A1	1/2019
2018/0271215 A1	9/2018	Foxen	EP	3434132 A1	1/2019
2018/0338568 A1	11/2018	Chambers et al.	EP	3174419 B1	7/2019
2018/0352902 A1	12/2018	Wardle	EP		

FOREIGN PATENT DOCUMENTS

US D1,023,531 S

Page 4

EP	3574791	A1	12/2019
EP	2938218	B1	3/2020
EP	3331393	B1	4/2020
EP	3316721	B1	5/2020
EP	3457882	B1	6/2020
EP	3355738	B1	8/2020
EP	3689171	A1	8/2020
EP	3771358	A1	2/2021
FR	2827126	A1	1/2003
FR	2932963	B1	8/2010
FR	2993758	B1	3/2015
GB	2376408	A	12/2002
JP	D1732464	*	12/2022
KR	100844183	B1	7/2008
TW	D145320		2/2012
TW	D154740		7/2013
VN	30025397		12/2017
VN	30025398		12/2017
VN	30025399		12/2017
WO	9842221	A1	10/1998
WO	2000074515	A1	12/2000
WO	2007113595	A2	10/2007
WO	2008125716	A1	10/2008
WO	2011020798	A1	2/2011
WO	2013023163	A1	2/2013
WO	2016094714	A1	6/2016
WO	2017023532	A1	2/2017
WO	2017120006	A1	7/2017
WO	2017151501	A1	9/2017
WO	2019157244	A1	8/2019
WO	2021016163	A1	1/2021

OTHER PUBLICATIONS

[Adidas Adizero], available on Amazon.com, Nov. 23, 2015 [online], [May 5, 2023], Available from the internet URL: https://www.amazon.com/adidas-Adizero-Prime-Collegiate-White/dp/B0119E37WS/ref=cm_cr_ar_p_d_product_top?ie=UTF8(Year: 2015).*

[Puma EvoSpeed Sprint 14], announced on YouTube on Jan. 5, 2023 [online], [site visited May 5, 2023], Available from the internet URL: PUMA evoSpeed Sprint 14 SKU: 9787857 (Year: 2023).*

International Search Report of International Application No. PCT/IB2021/062487, mailed Mar. 30, 2022, 7 pages.
Written Opinion of International Application No. PCT/IB2021/062487, mailed Mar. 30, 2022, 7 pages.
[adidas Adizero], available on Amazon.com, Nov. 23, 2015 [online], [May 5, 2023], Available from the internet URL: https://www.amazon.com/adidas-Adizero-Prime-Collegiate-White/dp/B0119E37WS/ref=cm_cr_ar_p_d_product_top?ie=UTF8(Year: 2015).

* cited by examiner

Primary Examiner — Jennifer L Rempfer

Assistant Examiner — Adrienne Corna

(74) *Attorney, Agent, or Firm* — Quarles & Brady LLP

(57)

CLAIM

The ornamental design for a shoe, as shown and described.

DESCRIPTION

FIG. 1 is a top, right, and front perspective view of an ornamental design for a shoe;

FIG. 2 is a left side elevational view of the shoe of FIG. 1;

FIG. 3 is a right side elevational view of the shoe of FIG. 1; and,

FIG. 4 is a bottom plan view of the shoe of FIG. 1.

The dash-dash-dash broken lines are included for the purpose of illustrating portions of the shoe that form no part of the claimed design. A transition in tonal contrast shown along the front cushion is claimed.

1 Claim, 4 Drawing Sheets

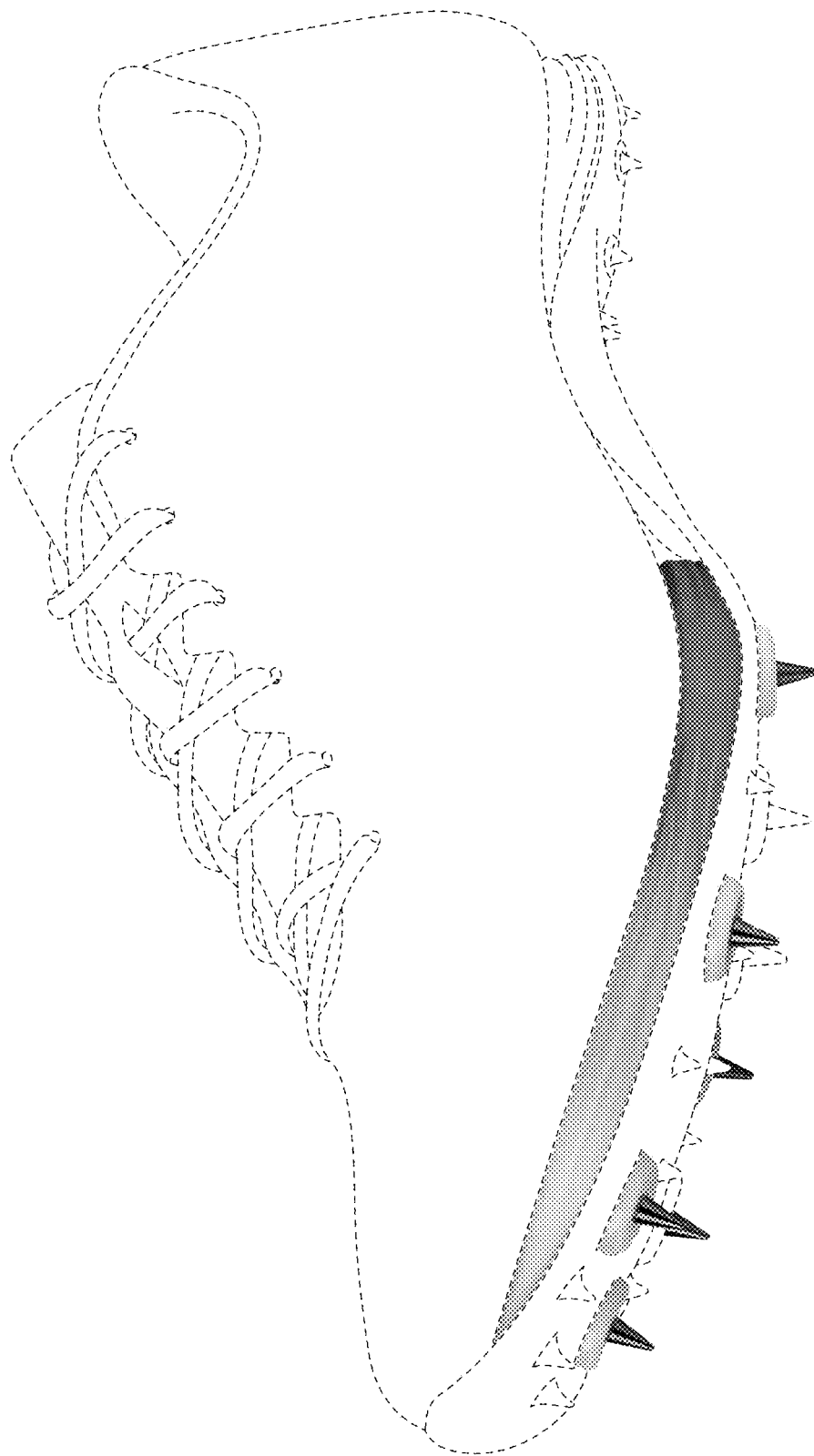

FIG. 1

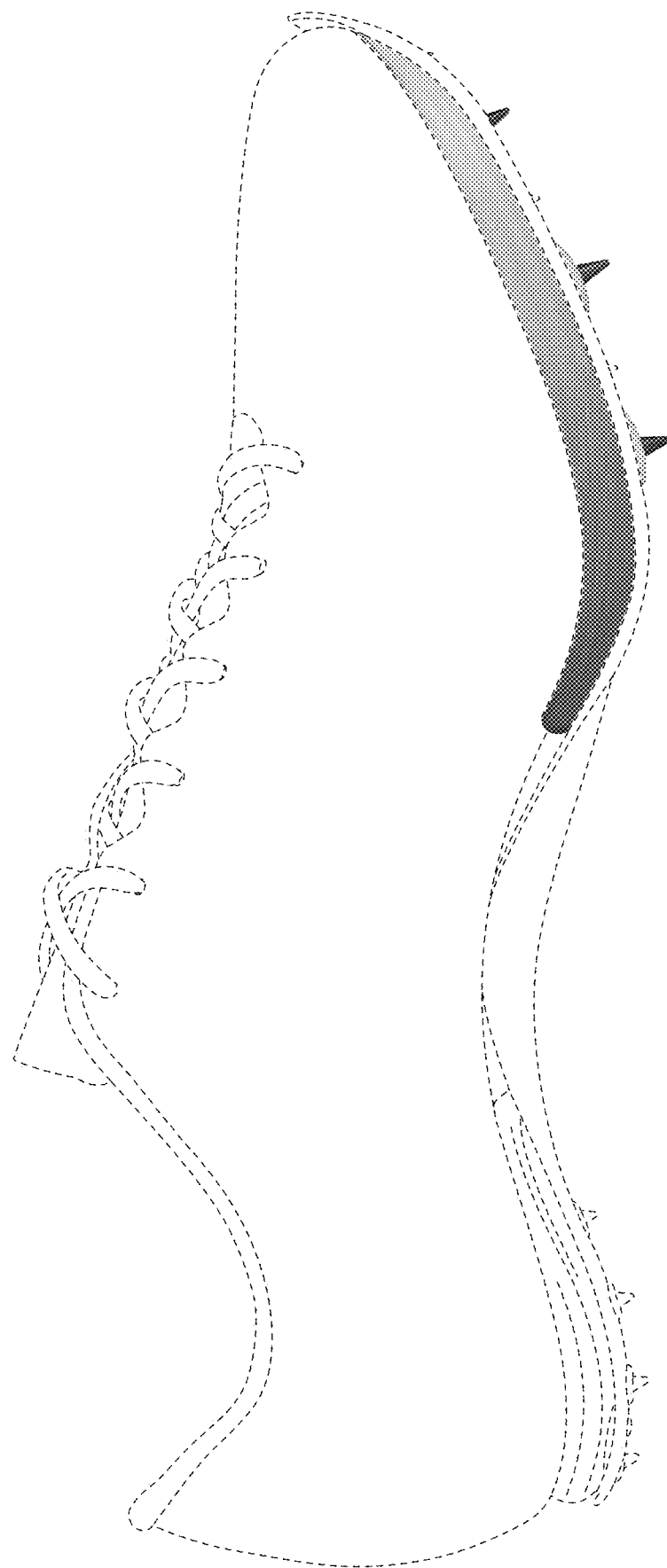

FIG. 2

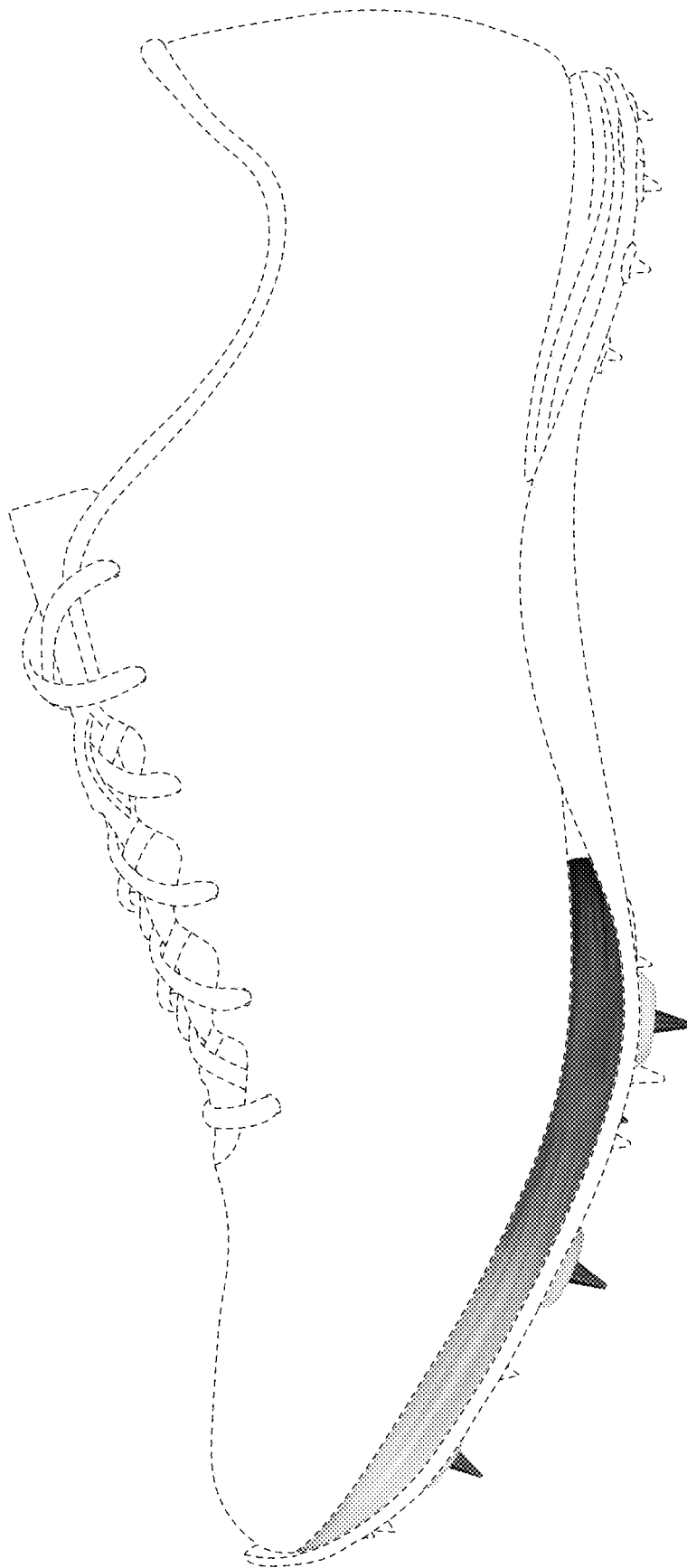

FIG. 3

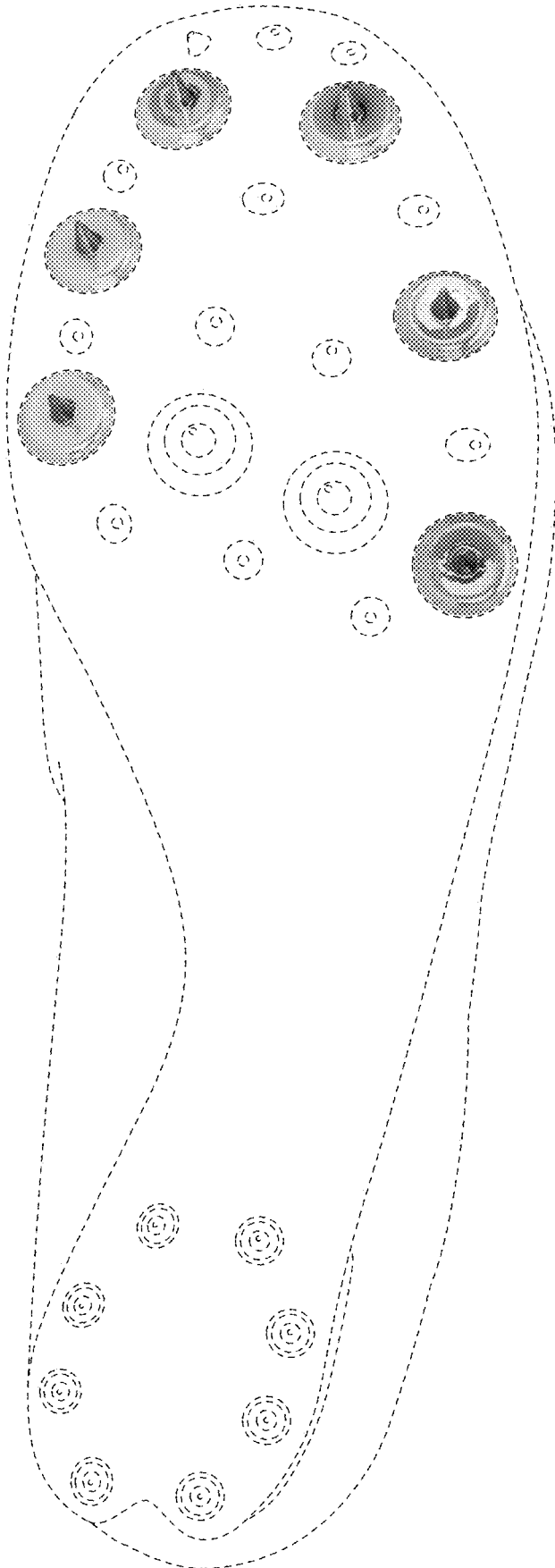

FIG. 4

EXHIBIT H



US0D1021356S

(12) **United States Design Patent** (10) **Patent No.:** **US D1,021,356 S**
Vella (45) **Date of Patent:** **** *Apr. 9, 2024**

- (54) **SHOE**
- (71) Applicant: **PUMA SE**, Herzogenaurach (DE)
- (72) Inventor: **Chris Vella**, Boston, MA (US)
- (73) Assignee: **PUMA SE**, Herzogenaurach (DE)
- (*) Notice: This patent is subject to a terminal disclaimer.
- (**) Term: **15 Years**
- (21) Appl. No.: **29/891,909**
- (22) Filed: **May 11, 2023**

- D377,411 S 1/1997 Murray
- D378,472 S 3/1997 Bramani
- D401,741 S 12/1998 Clarke
- D415,607 S 10/1999 Merceron
- D423,201 S 4/2000 Wilson
- D454,426 S 3/2002 Wilson

(Continued)

FOREIGN PATENT DOCUMENTS

- CA 70286 S 3/1992
- CA 70821 S 6/1992

(Continued)

OTHER PUBLICATIONS

[Saucony Endorphin Shift 3], available on heartbreak.run, [site visited Aug. 7, 2023], Internet URL: <https://heartbreak.run/products/saucony-womens-endorphin-shift-3-shoe> (Year: 2023).*

(Continued)

Primary Examiner — Jennifer L Rempfer
Assistant Examiner — Adrienne Corna
 (74) *Attorney, Agent, or Firm* — Quarles & Brady LLP

Related U.S. Application Data

- (63) Continuation of application No. 29/808,577, filed on Sep. 21, 2021.
- (51) **LOC (14) Cl.** **02-04**
- (52) **U.S. Cl.**
 USPC **D2/977; D2/947; D2/902**
- (58) **Field of Classification Search**
 USPC D2/902, 906, 908, 916, 918, 925, 943, D2/946-962, 972, 977
 CPC A43B 13/00; A43B 13/02; A43B 13/20; A43B 13/22; A43B 13/24; A43B 13/28; A43B 13/30; A43B 13/32; A43B 13/34; A43B 13/36; A43B 13/023; A43B 13/026; A43B 13/04; A43B 13/08; A43B 13/10; A43B 13/12; A43B 13/141; A43B 13/143; A43B 13/16; A43B 13/18; A43B 13/181; A43B 13/187; A43B 13/189; A43B 13/223
 See application file for complete search history.

(57) **CLAIM**

The ornamental design for a shoe, as shown and described.

DESCRIPTION

FIG. 1 is a top, left, and front perspective view of an ornamental design for a shoe;
 FIG. 2 is a left side elevational view of the shoe of FIG. 1;
 FIG. 3 is a right side elevational view of the shoe of FIG. 1; and,
 FIG. 4 is a front elevational view of the shoe of FIG. 1.
 The dash-dash-dash broken lines are included for the purpose of illustrating portions of the shoe that form no part of the claimed design.

1 Claim, 4 Drawing Sheets

- (56) **References Cited**
 U.S. PATENT DOCUMENTS
 D327,165 S 6/1992 Hatfield
 D350,638 S 9/1994 Yoshikawa

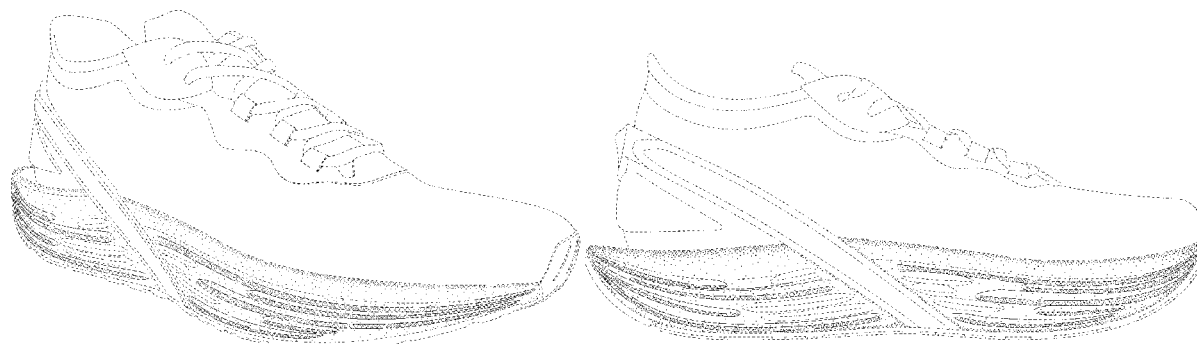

US D1,021,356 S

Page 2

(56)

References Cited

U.S. PATENT DOCUMENTS

D473,042 S 4/2003 Wilson
D473,047 S 4/2003 Wilson
D476,800 S 7/2003 Fuerst
D498,901 S 11/2004 Hawker
D507,398 S 7/2005 Recchi
D511,617 S 11/2005 Matis
D615,738 S 5/2010 Teteriatnikov
D637,803 S 5/2011 Alvear
D643,189 S * 8/2011 Teteriatnikov D2/977
D666,795 S * 9/2012 Shaffer D2/947
D672,123 S 12/2012 Williams, Jr.
D680,308 S * 4/2013 Hardman D2/947
D685,166 S 7/2013 Hatfield
D690,088 S 9/2013 Hardman
D692,217 S 10/2013 Fogg
D694,497 S * 12/2013 Taylor D2/947
D694,498 S 12/2013 Carboy
D694,499 S * 12/2013 Williams, Jr. D2/947
D710,579 S 8/2014 Williams, Jr.
D713,625 S 9/2014 Raasch
D713,626 S 9/2014 Raasch
D714,035 S 9/2014 O'Connor
D731,767 S * 6/2015 Lan D2/947
D743,153 S 11/2015 Taylor
D746,560 S 1/2016 Verfl
D747,083 S 1/2016 Verfl
D756,620 S 5/2016 Boys
D768,969 S 10/2016 Boys
D770,739 S 11/2016 Nethongkome
D770,740 S 11/2016 Teteriatnikov
D779,175 S 2/2017 Greenhalgh
D782,790 S 4/2017 Lee
D789,054 S 6/2017 Shyllon
D790,169 S 6/2017 da Costa Pereira Machado
D790,183 S 6/2017 VanHook
D791,453 S 7/2017 McMillan
D793,046 S 8/2017 Lee
D795,541 S 8/2017 Henrichot
D796,168 S 9/2017 Shyllon
D796,799 S * 9/2017 Shyllon D2/947
D798,551 S 10/2017 Shyllon
D798,554 S 10/2017 Swierszczk
D798,555 S 10/2017 Enayah
D798,558 S 10/2017 Pauk
D810,411 S 2/2018 Klein
D812,871 S 3/2018 Reyes
D815,816 S 4/2018 Cin
D815,817 S 4/2018 Cin
D815,818 S 4/2018 Cin
D815,820 S 4/2018 Cin
D815,821 S 4/2018 Cin
D815,822 S 4/2018 Cin
D815,823 S 4/2018 Cin
D816,310 S 5/2018 Cooper
D816,311 S 5/2018 Cin
D816,959 S 5/2018 Cin
D816,960 S 5/2018 Cin
D817,614 S 5/2018 Cin
D817,615 S 5/2018 Cin
D817,616 S 5/2018 Cin
D834,795 S * 12/2018 Vasyli D2/947

D847,478 S 5/2019 Fracassi
D853,097 S 7/2019 Cass
D853,701 S 7/2019 Hong
D855,301 S * 8/2019 Williams, Jr. D2/947
D862,046 S 10/2019 Page
D870,429 S 12/2019 Becker
D874,098 S * 2/2020 Hartmann D2/902
D882,918 S 5/2020 Kosenick
D885,718 S 6/2020 Roulo
D889,798 S 7/2020 Vella
D890,484 S * 7/2020 Williams, Jr. D2/947
D907,903 S * 1/2021 Garcia D2/947
D912,947 S 3/2021 Boys
D912,948 S 3/2021 Boys
D913,655 S 3/2021 Boys
D913,668 S 3/2021 Boys
D917,848 S 5/2021 Wehrmeyer
D922,741 S 6/2021 Boys
D922,742 S 6/2021 Boys
D929,097 S 8/2021 Winskowicz
D938,145 S 12/2021 Rezab
D940,443 S 1/2022 Papp
D948,853 S 4/2022 Jenkins
D950,211 S 5/2022 Tejada Bernard
D976,564 S 1/2023 Klug
D978,508 S 2/2023 Schneider
D992,258 S * 7/2023 Raleigh D2/947

FOREIGN PATENT DOCUMENTS

CA 97079 S 5/2002
CA 97944 S 6/2003
CA 142281 S 4/2012
CA 145865 S 2/2013
CA 147979 S 12/2013
CA 148731 S 1/2014
CA 150008 S 1/2014
CA 151213 S 3/2014
CA 151413 S 4/2014
CA 151425 S 4/2014
CA 151434 S 4/2014
CA 155362 S 10/2014
CA 155411 S 11/2014
CA 155435 S 3/2015
CA 155436 S 3/2015
CA 159823 S 7/2015
CA 165390 S 6/2016
CA 169350 S 7/2017
CA 169349 S 1/2018
EM 015026166-0001 * 6/2023
TW 145320 S 2/2012
TW 154740 S 7/2013
VN 30025397 S1 12/2017
VN 30025398 S1 12/2017
VN 30025399 S1 12/2017

OTHER PUBLICATIONS

[Puma Run XX Nitro Review], available on doctorsofrunning.com, [site visited Aug. 7, 2023], Internet URL: <https://www.doctorsofrunning.com/2022/07/puma-run-xx-nitro-review-2022.html> (Year: 2022).*

* cited by examiner

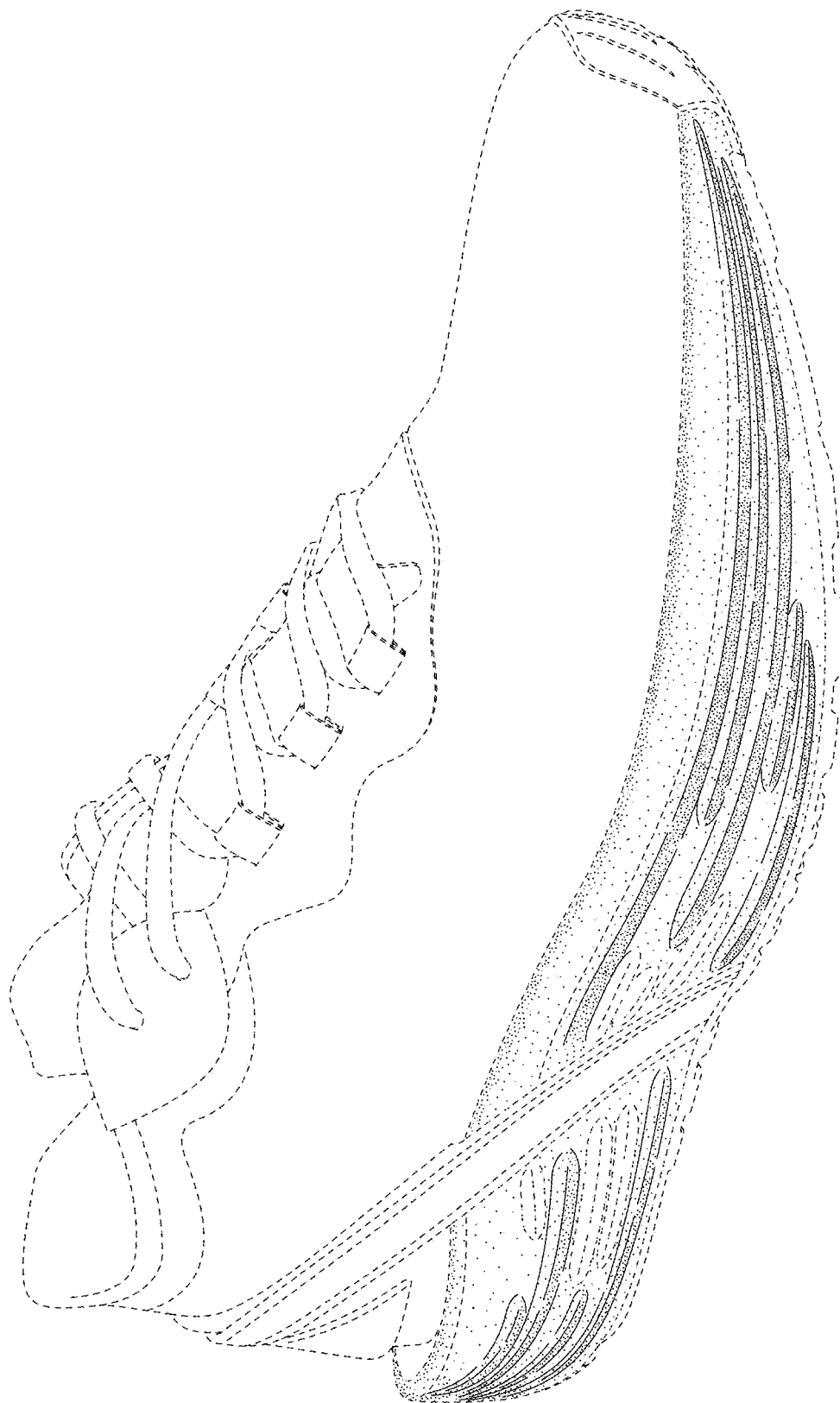

FIG. 1

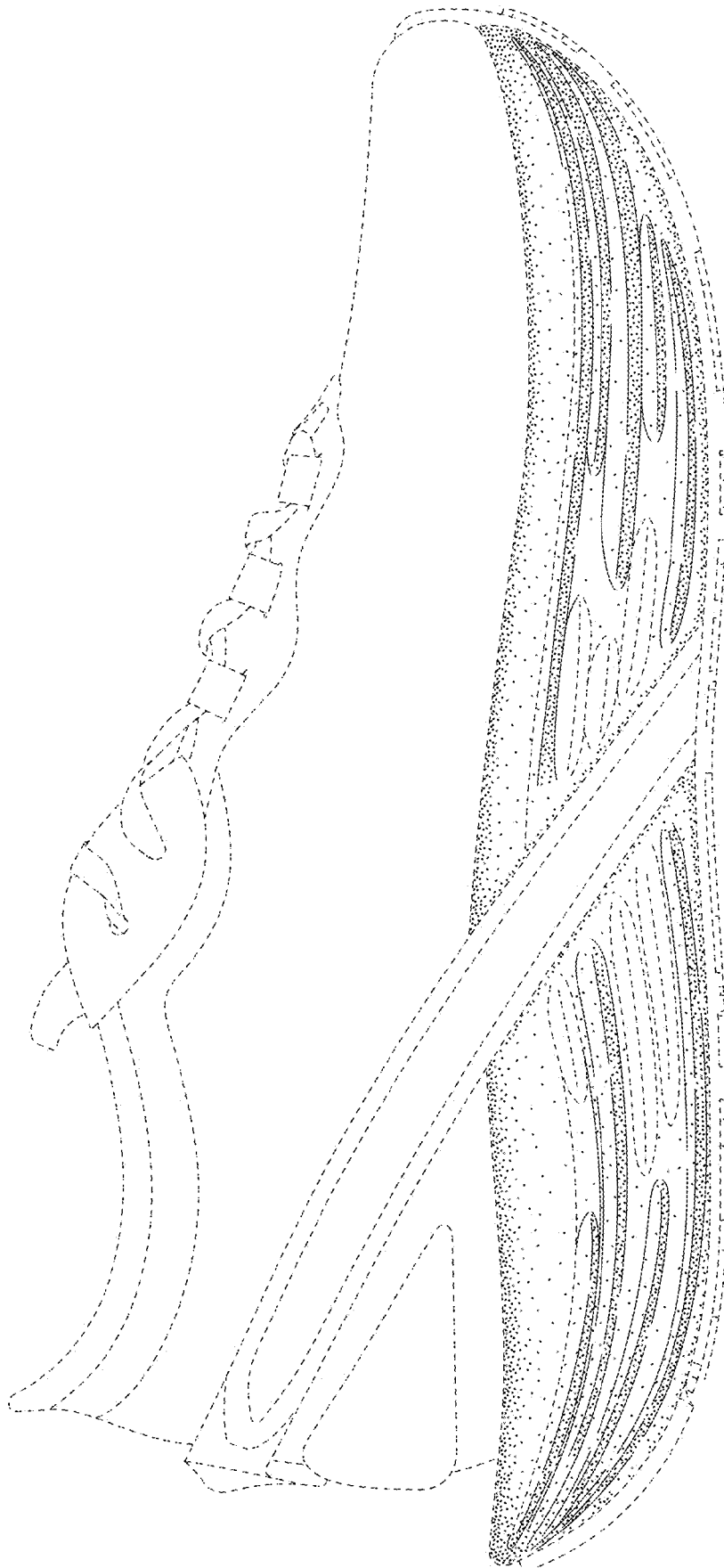

FIG. 2

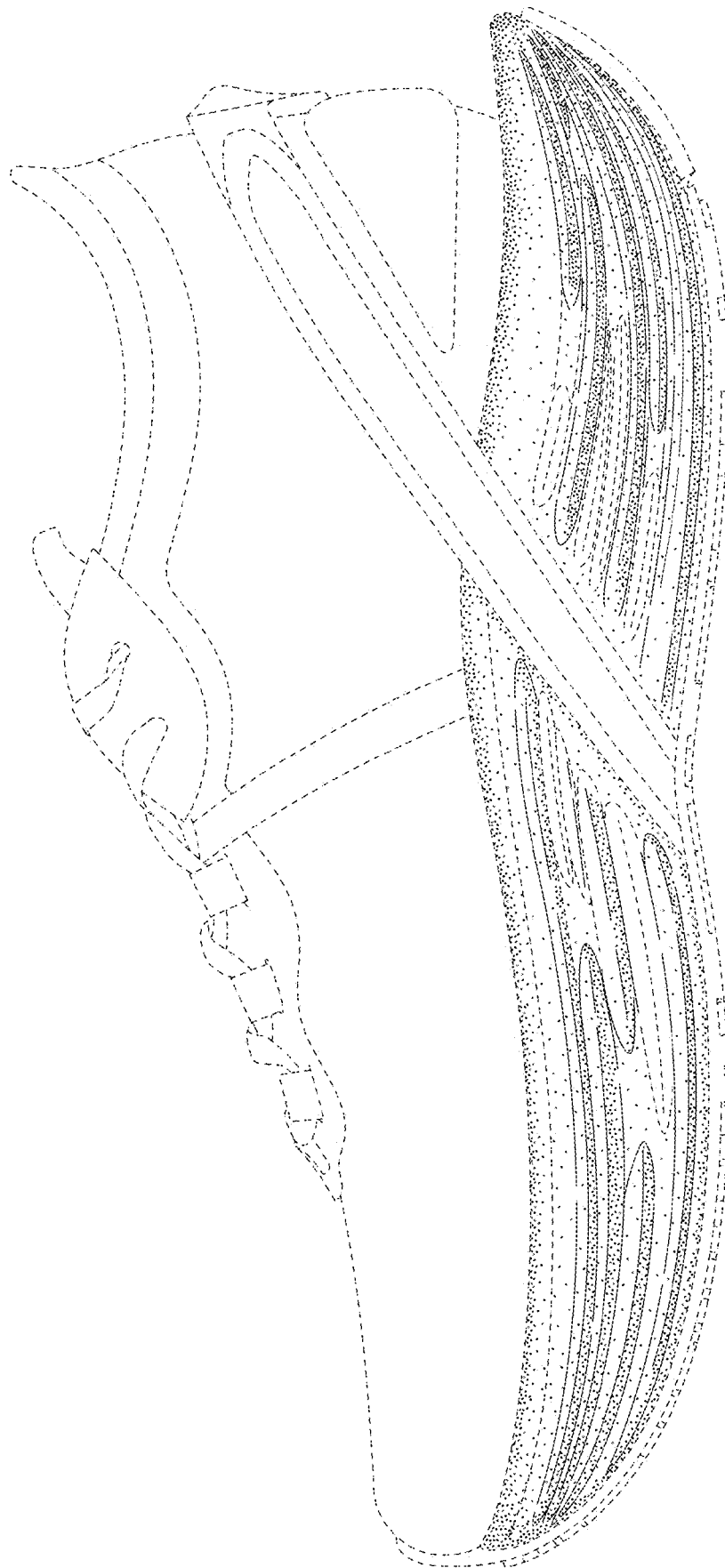

FIG. 3

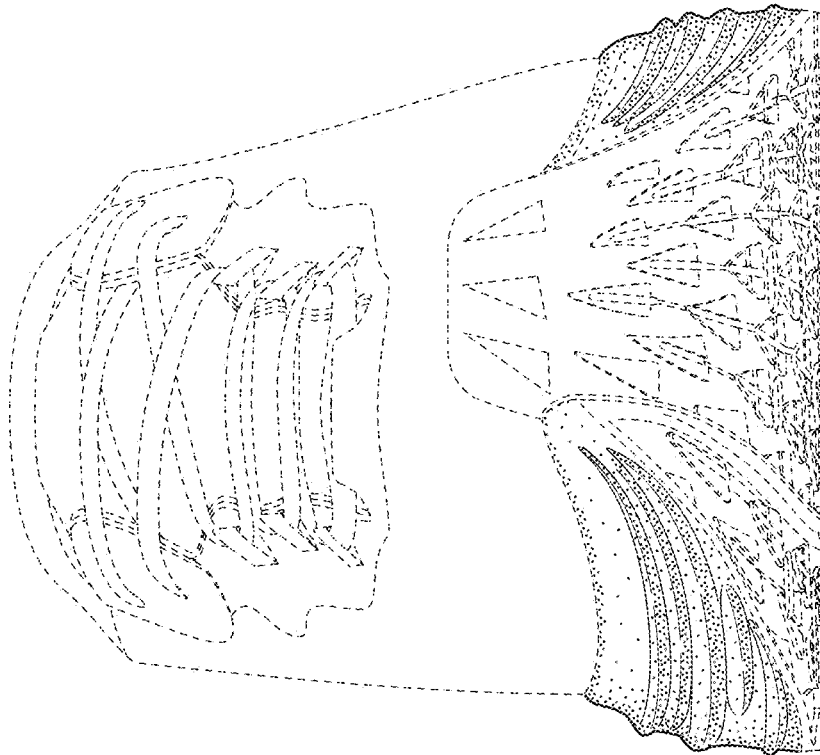

FIG. 4

EXHIBIT I



US0D1009432S

(12) **United States Design Patent** (10) **Patent No.:** **US D1,009,432 S**
Siegismund et al. (45) **Date of Patent:** **** Jan. 2, 2024**

(54) **SHOE**
 (71) Applicant: **PUMA SE**, Herzogenaurach (DE)
 (72) Inventors: **Andreas Siegismund**, Rückersdorf (DE); **Romain Girard**, Lauf an der Pegnitz (DE)
 (73) Assignee: **PUMA SE**, Herzogenaurach (DE)
 (**) Term: **15 Years**

D364,728 S 12/1995 Nozu
 D366,354 S 1/1996 Yoshikawa
 D377,411 S 1/1997 Murray
 D378,472 S 3/1997 Bramani
 D395,341 S * 6/1998 Greenberg D2/957
 D401,741 S 12/1998 Clarke
 D410,691 S 6/1999 Boyer
 D414,023 S 9/1999 Cretinon
 D415,607 S 10/1999 Merceron
 (Continued)

(21) Appl. No.: **29/892,741**
 (22) Filed: **May 22, 2023**

FOREIGN PATENT DOCUMENTS

CA 70286 S 3/1992
 CA 70821 S 6/1992
 (Continued)

Related U.S. Application Data

(63) Continuation of application No. 29/891,899, filed on May 11, 2023, which is a continuation of application No. 29/760,391, filed on Dec. 1, 2020.

(51) **LOC (14) Cl.** **02-04**
 (52) **U.S. Cl.** **D2/947**
 USPC

(58) **Field of Classification Search**
 USPC D2/896, 900, 902, 904, 906-908, D2/916-924, 925-945, 947-960, 969-979
 CPC A43B 1/00; A43B 1/02; A43B 1/04; A43B 3/00; A43B 3/02; A43B 3/06; A43B 3/10; A43B 3/12; A43B 3/14; A43B 5/00; A43B 5/001; A43B 5/008; A43B 5/06; A43B 5/10; A43B 5/12; A43B 23/00; A43B 23/02; A43B 23/04
 See application file for complete search history.

(56) **References Cited**

U.S. PATENT DOCUMENTS

D266,798 S * 11/1982 Famolare, Jr. D2/950
 D327,165 S 6/1992 Hatfield
 D350,638 S 9/1994 Yoshikawa

OTHER PUBLICATIONS

Best Puma Running Shoes of 2023_ What We Know, posted Jan. 3, 2023 [online], [retrieved Aug. 16, 2023]. Retrieved from internet, <https://believeintherun.com/shoe-reviews/best-puma-running-shoes-of-2023/> (Year: 2023).*

(Continued)

Primary Examiner — Jonathan J Han
Assistant Examiner — Christen Pilar Brown
 (74) *Attorney, Agent, or Firm* — Quarles & Brady LLP

(57) **CLAIM**

The ornamental design for a shoe, as shown and described.

DESCRIPTION

FIG. 1 is a top, right, front perspective view of an ornamental design for a shoe; and, FIG. 2 is a right side elevational view of the shoe of FIG. 1. The dash-dash-dash broken lines are included for the purpose of illustrating portions of the shoe that form no part of the claimed design.

1 Claim, 2 Drawing Sheets

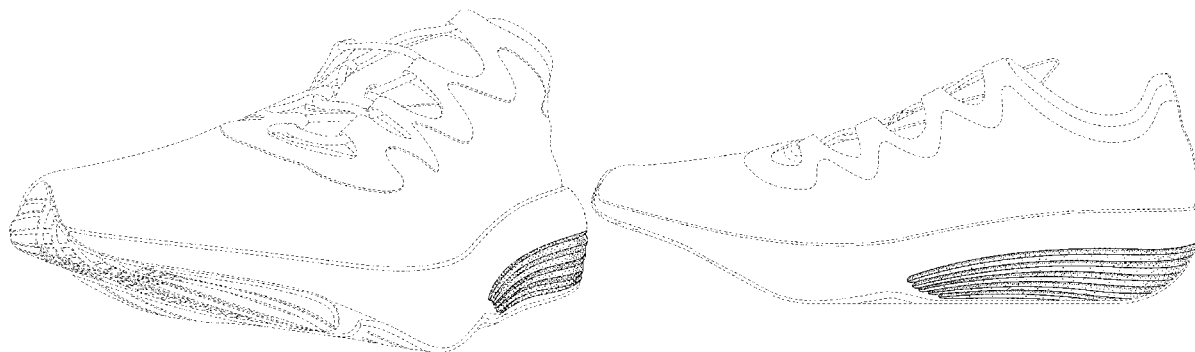

US D1,009,432 S

Page 2

(56)

References Cited

U.S. PATENT DOCUMENTS

D423,201 S	4/2000	Wilson	D798,551 S	10/2017	Shyllon
D433,214 S	11/2000	McDowell	D798,554 S	10/2017	Swierszczk
D433,791 S	11/2000	Laberge	D798,555 S	10/2017	Enayah
D436,718 S	1/2001	Patterson	D798,558 S	10/2017	Pauk
D439,031 S	3/2001	Matis	D810,411 S	2/2018	Klein
D450,439 S	11/2001	Wilson	D812,871 S	3/2018	Reyes
D454,426 S	3/2002	Wilson	D815,816 S	4/2018	Cin
D459,864 S	7/2002	Butler	D815,817 S	4/2018	Cin
D466,278 S *	12/2002	Smith, III D2/977	D815,818 S	4/2018	Cin
D473,042 S	4/2003	Wilson	D815,820 S	4/2018	Cin
D473,047 S	4/2003	Wilson	D815,821 S	4/2018	Cin
D473,697 S	4/2003	Gillespie	D815,822 S	4/2018	Cin
D476,800 S	7/2003	Fuerst	D815,823 S	4/2018	Cin
D498,901 S	11/2004	Hawker	D816,310 S	5/2018	Cooper
D507,398 S	7/2005	Recchi	D816,311 S	5/2018	Cin
D511,617 S	11/2005	Matis	D816,959 S	5/2018	Cin
D528,751 S	9/2006	Pawlus	D816,960 S	5/2018	Cin
D530,491 S	10/2006	Sonnergren	D817,614 S	5/2018	Cin
D546,035 S	7/2007	Belley	D817,615 S	5/2018	Cin
D554,831 S	11/2007	Lotti	D817,616 S	5/2018	Cin
D557,481 S	12/2007	Hui	D834,795 S *	12/2018	Vasyli D2/947
D565,283 S	4/2008	Smith	D847,478 S	5/2019	Fracassi
D576,393 S *	9/2008	Kaufman D2/947	D853,097 S	7/2019	Cass
D579,636 S	11/2008	Graber	D853,701 S	7/2019	Hong
D592,383 S	5/2009	Wawrousek	D855,301 S	8/2019	Williams, Jr.
D615,738 S	5/2010	Teteriatnikov	D862,046 S	10/2019	Page
D624,735 S	10/2010	Raysse	D866,932 S	11/2019	Verfl
D626,315 S	11/2010	Teteriatnikov	D870,429 S	12/2019	Becker
D634,918 S *	3/2011	Katz D2/943	D882,918 S	5/2020	Kosenick
D637,803 S	5/2011	Alvear	D885,718 S	6/2020	Roulo
D643,189 S *	8/2011	Teteriatnikov D2/977	D889,798 S	7/2020	Vella
D662,698 S *	7/2012	Pulli D2/947	D891,059 S	7/2020	Shyllon
D666,795 S	9/2012	Shaffer	D893,148 S	8/2020	de Montgolfier
D671,723 S *	12/2012	Teteriatnikov D2/947	D893,154 S	8/2020	de Montgolfier
D672,123 S	12/2012	Williams, Jr.	D894,574 S	9/2020	de Montgolfier
D677,040 S	3/2013	Vestuti	D912,947 S	3/2021	Boys
D677,866 S	3/2013	Vestuti	D912,948 S	3/2021	Boys
D680,308 S	4/2013	Hardman	D913,655 S	3/2021	Boys
D685,166 S	7/2013	Hatfield	D913,668 S	3/2021	Boys
D690,088 S	9/2013	Hardman	D917,848 S	5/2021	Wehrmeyer
D692,217 S	10/2013	Fogg	D922,741 S	6/2021	Boys
D694,498 S	12/2013	Carboy	D922,742 S	6/2021	Boys
D694,499 S	12/2013	Williams, Jr.	D929,097 S	8/2021	Winskowicz
8,607,474 B2 *	12/2013	Spanks B29D 35/126 36/4	D938,145 S	12/2021	Rezab
D696,852 S *	1/2014	Madore D2/972	D940,443 S	1/2022	Papp
D697,293 S	1/2014	Vestuti	D948,853 S	4/2022	Jenkins
D710,579 S	8/2014	Williams, Jr.	D950,211 S	5/2022	Tejada Bernard
D713,625 S	9/2014	Raasch	D950,212 S *	5/2022	Tejada Bernard D2/947
D713,626 S	9/2014	Raasch	D976,564 S	1/2023	Klug
D714,035 S	9/2014	O'Connor	D978,508 S	2/2023	Schneider
D731,767 S	6/2015	Lan	2011/0225852 A1 *	9/2011	Mahoney A43B 13/12 36/30 R
D737,040 S *	8/2015	Pauk D2/972	2014/0150298 A1 *	6/2014	Crowley A43B 7/144 36/103
D742,107 S *	11/2015	Kasprzak D2/951	2014/0259788 A1 *	9/2014	Dojan A43B 13/186 36/103
D743,153 S	11/2015	Taylor	2014/0259789 A1 *	9/2014	Dojan A43B 13/127 36/103
D746,560 S	1/2016	Verfl	2017/0150777 A1 *	6/2017	Youngs A43B 7/20
D747,083 S	1/2016	Verfl	2017/0208896 A1 *	7/2017	Mokos A43B 23/0235
D756,620 S	5/2016	Boys	2022/0022595 A1	1/2022	Girard
D768,969 S	10/2016	Boys			
D770,739 S	11/2016	Nethongkome			
D770,740 S	11/2016	Teteriatnikov			
D777,413 S	1/2017	Hermes			
D779,175 S	2/2017	Greenhalgh	CA	97079 S	5/2002
D781,541 S *	3/2017	McGhee D2/947	CA	97944 S	6/2003
D781,542 S *	3/2017	McGhee D2/947	CA	142281 S	4/2012
D782,790 S	4/2017	Lee	CA	145865 S	2/2013
D784,671 S	4/2017	Little	CA	147979 S	12/2013
D789,054 S	6/2017	Shyllon	CA	148731 S	1/2014
D790,169 S	6/2017	da Costa Pereira Machado	CA	150008 S	1/2014
D790,183 S	6/2017	VanHook	CA	151213 S	3/2014
D791,453 S	7/2017	McMillan	CA	151413 S	4/2014
D793,046 S	8/2017	Lee	CA	151425 S	4/2014
D795,541 S	8/2017	Henrichot	CA	151434 S	4/2014
D796,168 S	9/2017	Shyllon	CA	155362 S	10/2014
D796,799 S	9/2017	Shyllon	CA	155411 S	11/2014
			CA	155435 S	3/2015

FOREIGN PATENT DOCUMENTS

US D1,009,432 SPage 3

(56)

References Cited

FOREIGN PATENT DOCUMENTS

CA	155436 S	3/2015
CA	159823 S	7/2015
CA	165390 S	6/2016
CA	169350 S	7/2017
CA	169349 S	1/2018
TW	145320 S	2/2012
TW	154740 S	7/2013
VN	30025397 S1	12/2017
VN	30025398 S1	12/2017
VN	30025399 S1	12/2017

OTHER PUBLICATIONS

Adidas Black Suede Runner, posted Feb. 25, 2016 [online]. [Retrieved Oct. 3, 2022]. Retrieved from internet, <https://www.grailed.com/listings/3862243-adidas-x-rick-owens-black-suede-runner> (Oct. 3, 2022), 5 pages.

Deviate Nitro 2 Womens Running Shoes, posted 2022 [online], [Retrieved Sep. 29, 2022]. Retrieved from internet, <https://us.puma.com/us/en/pd/deviate-nitro-2-womens-running-shoes/376855swatch=04> (Sep. 29, 2022), 3 pages.

Pwrframe Mens Training Shoes, posted 2022 [online], [Retrieved Sep. 29, 2022]. Retrieved from internet, <https://us.puma.com/us/en/pd/pwrframe-mens-training-shoes/376049swatch=08> (Sep. 29, 2022), 4 pages.

Velocity Nitro WTR Womens Running Shoes, posted 2022 [online], [Retrieved Sep. 29, 2022]. Retrieved from internet, <https://us.puma.com/us/en/pd/velocity-nitro-wtr-womens-running-shoes/195296swatch=01> (Sep. 29, 2022), 5 pages.

* cited by examiner

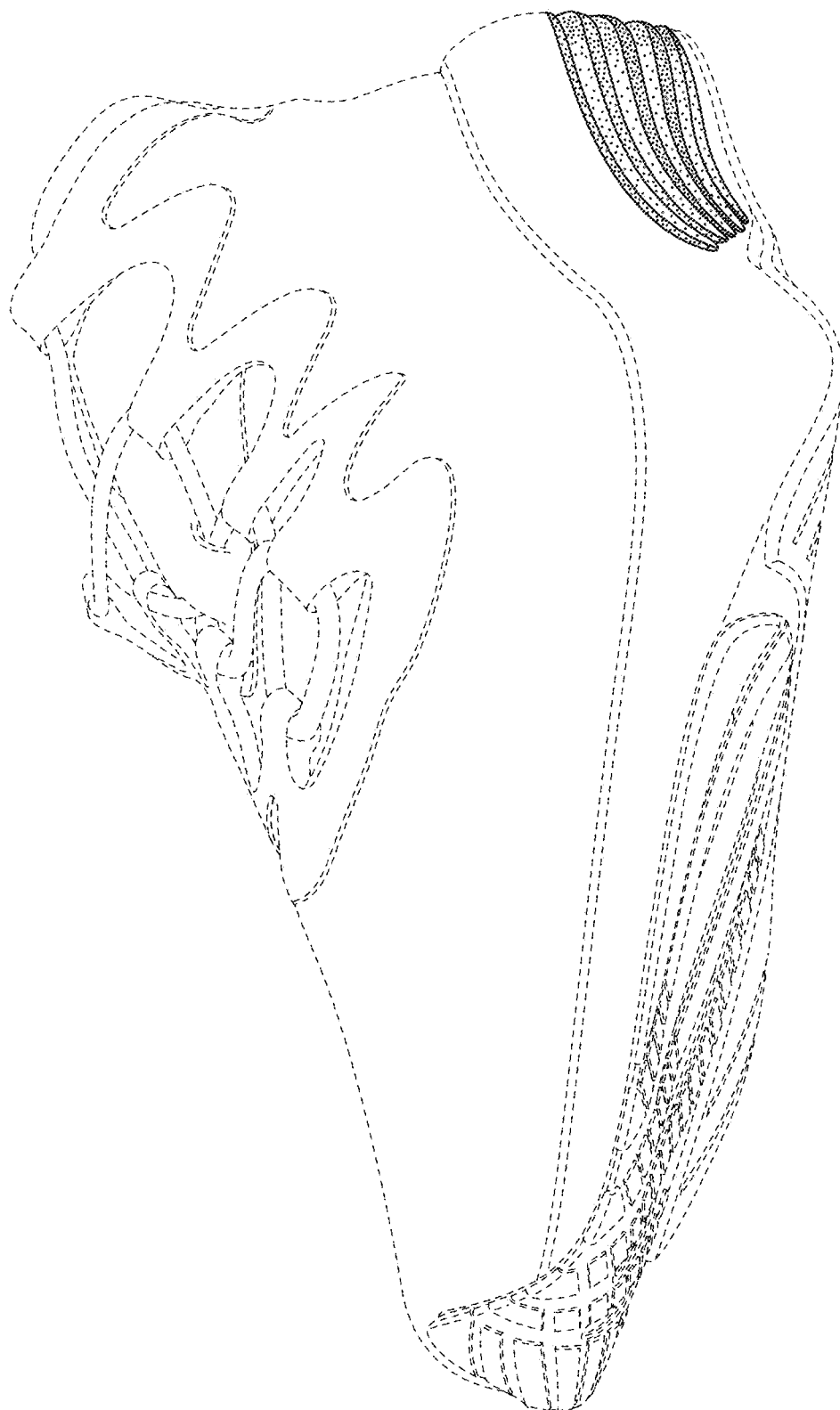

FIG. 1

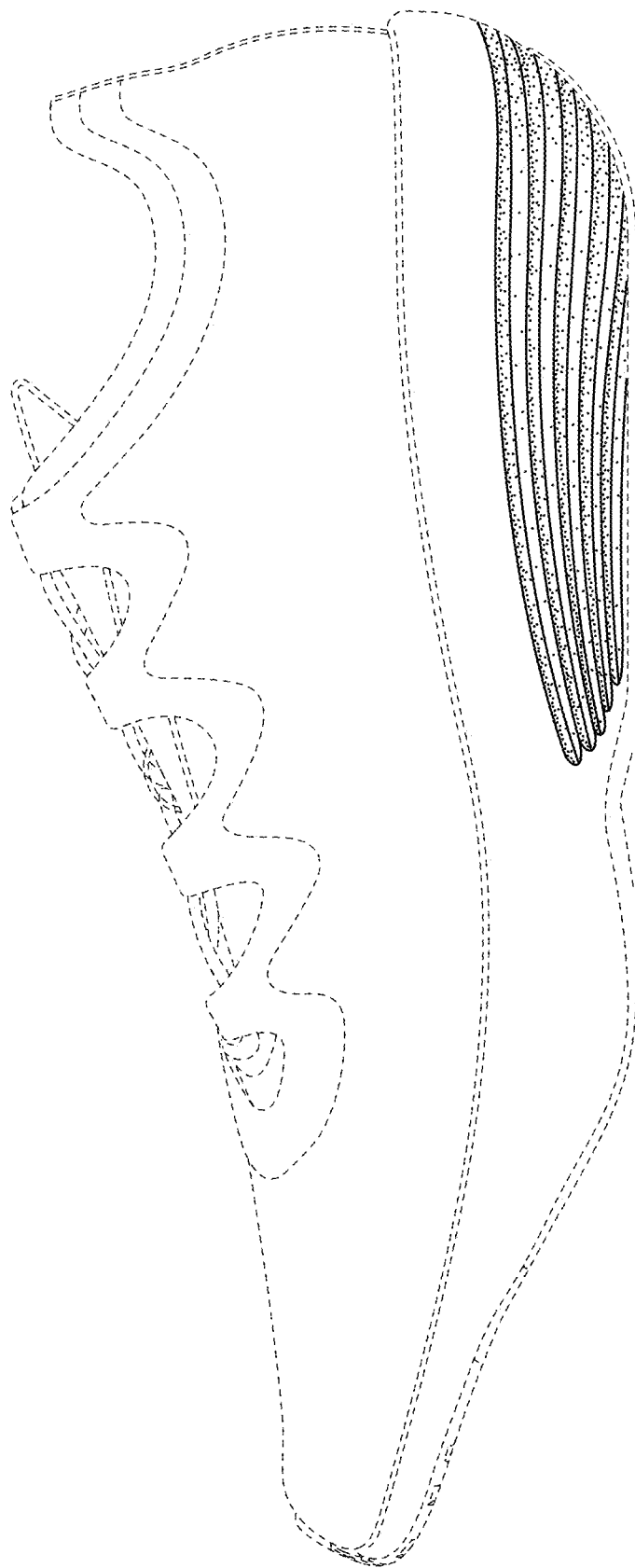

FIG. 2