

IN THE UNITED STATES DISTRICT COURT  
FOR THE NORTHERN DISTRICT OF ILLINOIS  
EASTERN DIVISION

Guangdongsheng  
uanmei Co., Ltd.,

Plaintiff,

v.

THE PARTNERSHIPS and UNIN-  
CORPORATED ASSOCIATIONS  
IDENTIFIED ON SCHEDULE "A",

Defendants.

Case No. 24-CV-5863

**COMPLAINT**

Plaintiff Guangdongsheng Shunhechuanmei Co., Ltd. ("Shunhechuanmei"), by and through its attorneys, The Law Offices of Konrad Sherinian, LLC, hereby brings the present action against the Partnerships and Unincorporated Associations (collectively, "Defendants") identified on Schedule A attached to the complaint and alleges as follows:

**JURISDICTION AND VENUE**

1. This is an action for patent infringement. This Court has original subject matter jurisdiction over the federal claims in this action pursuant to the provisions of the Patent Act, 35 U.S.C. § 1, et seq., 28 U.S.C. § 1338(a)-(b) and 28 U.S.C. § 1331.

2. Venue is proper in this Court pursuant to 28 U.S.C. § 1391 and this Court may properly exercise personal jurisdiction over Defendants. Each of the Defendants directly targets business activities toward consumers in the United States, including Illinois, through their operation of, or assistance in the operation of, the fully interactive, commercial Internet stores operating under the seller aliases and online marketplace accounts identified in Schedule A attached hereto (collectively, the “Seller Aliases”), as well as the shipment of products offered for sale on those Defendant Online Stores. Specifically, Defendants are involved in the production, listing for sale, sale, and/or shipping of products to Illinois residents that use infringing products featuring Shunhechuanmei’s patented design to residents of Illinois. Each of the Defendants is committing tortious acts in Illinois, is engaging in interstate commerce, is targeting sales to Illinois residents, and has wrongfully caused Shunhechuanmei substantial injury in the State of Illinois.

3. This Court has personal jurisdiction over each Defendant, in that each Defendant conducts significant business in Illinois and in this judicial district, and the acts and events giving rise to this lawsuit of which each Defendant stands accused were undertaken in Illinois and in this judicial district.

#### **PRIOR RELATED CASES**

4. Pursuant to LR40.4 this case is related to earlier filed case 2024-cv-748, which dealt or deals with some of the same intellectual property as this case.

#### **NATURE OF THE CASE**

5. This action has been filed by Shunhechuanmei to combat e-commerce store operators who trade upon Shunhechuanmei’s reputation and goodwill by making, using, offering for sale, selling and/or importing into the United States for subsequent sale

or use the same unauthorized and unlicensed product, namely the metal nibbler drill attachment apparatus, such as the one shown in Exhibit 1, that infringes Shunhechuanmei's patented design, U.S. Patent No. D1,006,076 (the "Infringing Products"). Defendants create e-commerce stores operating under one or more Seller Aliases that are making, using, offering for sale, selling, and/or importing into the United States for subsequent sale or use Infringing Products to unknowing consumers. E-commerce stores operating under the Seller Aliases share unique identifiers establishing a logical relationship between them, suggesting that Defendants' operation arises out of the same transaction, occurrence, or series of transactions or occurrences. Defendants attempt to avoid and mitigate liability by operating under one or more Seller Aliases to conceal both their identities and the full scope and interworking of their operation. Shunhechuanmei has filed this action to combat Defendants' infringement of its patented design, as well as to protect unknowing consumers from purchasing Infringing Products over the Internet. Shunhechuanmei has been and continues to be irreparably damaged from the loss of its lawful patent rights to exclude others from making, using, selling, offering for sale, and importing its patented design as a result of Defendants' actions and seeks injunctive and monetary relief.

### **PARTIES**

6. Plaintiff Guangdongsheng Shunhechuanmei Co., Ltd. is a Chinese company having its principal place of business in the city of Foshanshi, Guangdong Province, China.

7. Shunhechuanmei has been engaged in the business of designing, manufacturing and marketing machinery tools, such as metal nibbler drill attachments, (collectively, the “Shunhechuanmei Products”). Shunhechuanmei Products can be purchased from e-commerce platforms, such as Amazon.com. Since at least 2023, Shunhechuanmei has marketed, advertised, promoted, distributed and sold Shunhechuanmei Products to consumers in the United States. Shunhechuanmei Products have become very popular, driven by Shunhechuanmei’s arduous quality standards and Shunhechuanmei Products’ unique and innovative design. As a result, among the purchasing public, genuine Shunhechuanmei Products are instantly recognizable as such. In the United States and around the world, the Shunhechuanmei brand has come to symbolize high quality metal nibbler drill attachment tools.

8. Shunhechuanmei Products are known for their distinctive patented designs. These designs are broadly recognized by consumers. metal nibbler drill attachment tool products styled after these designs are associated with the quality and innovation that the public has come to expect from Shunhechuanmei Products. Shunhechuanmei uses these designs in connection with its Shunhechuanmei Products, including, but not limited to, the following patented design, herein referred to as the “Shunhechuanmei Design.”

<b>Patent Number</b>	<b>Claim</b>	<b>Issue Date</b>
----------------------	--------------	-------------------

D1,006,076

Nov. 28,  
2023

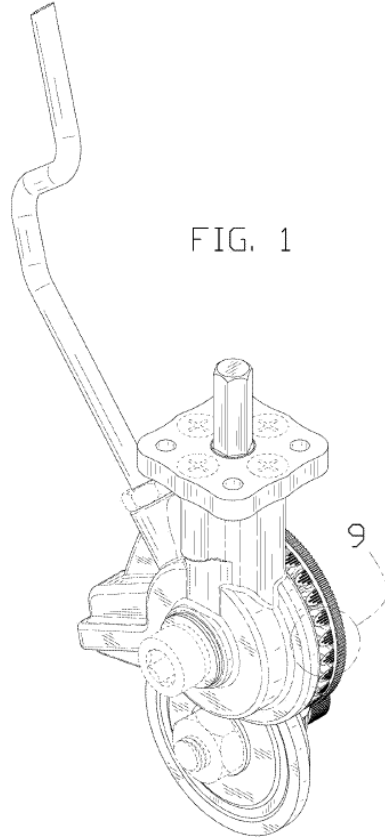

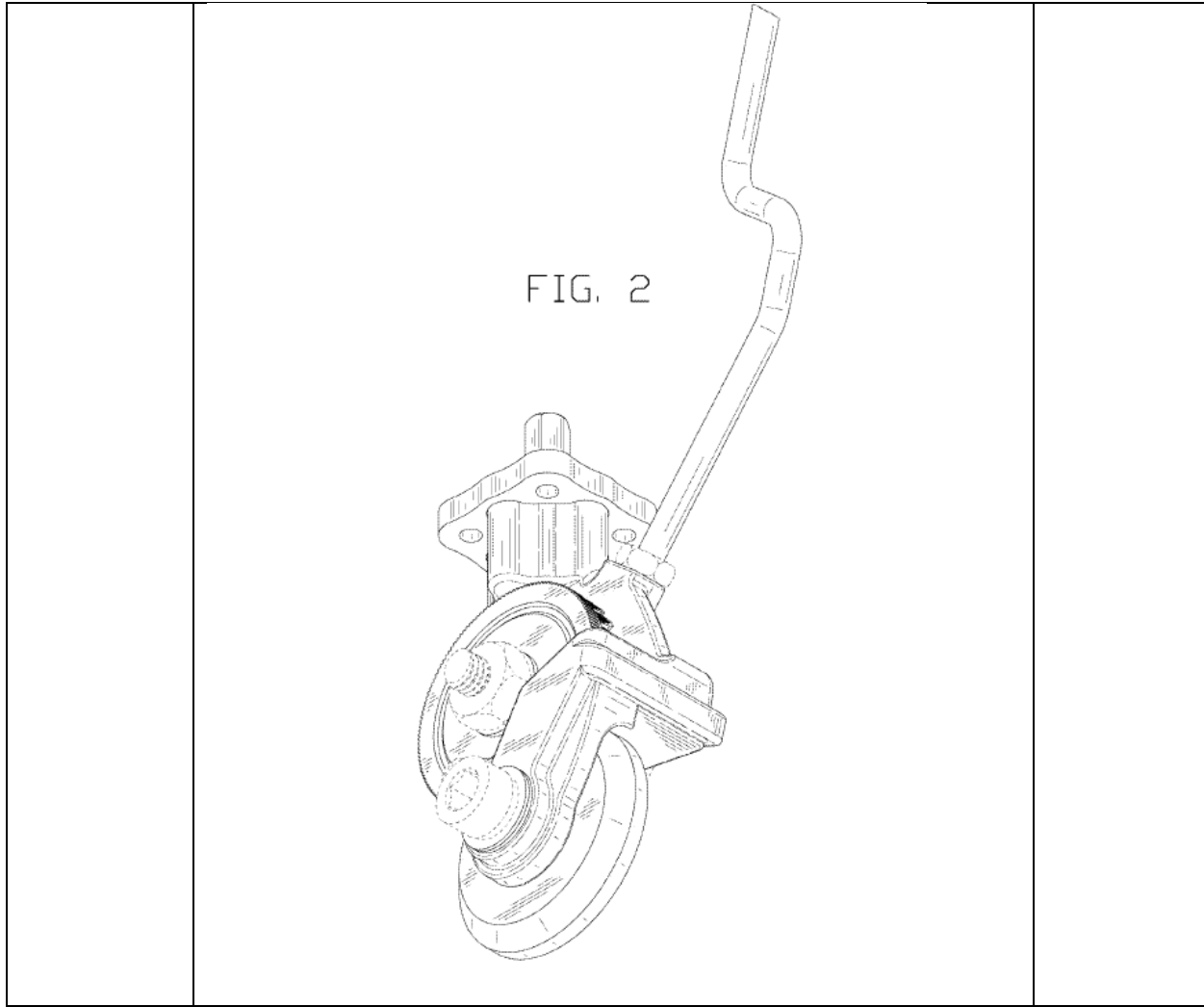

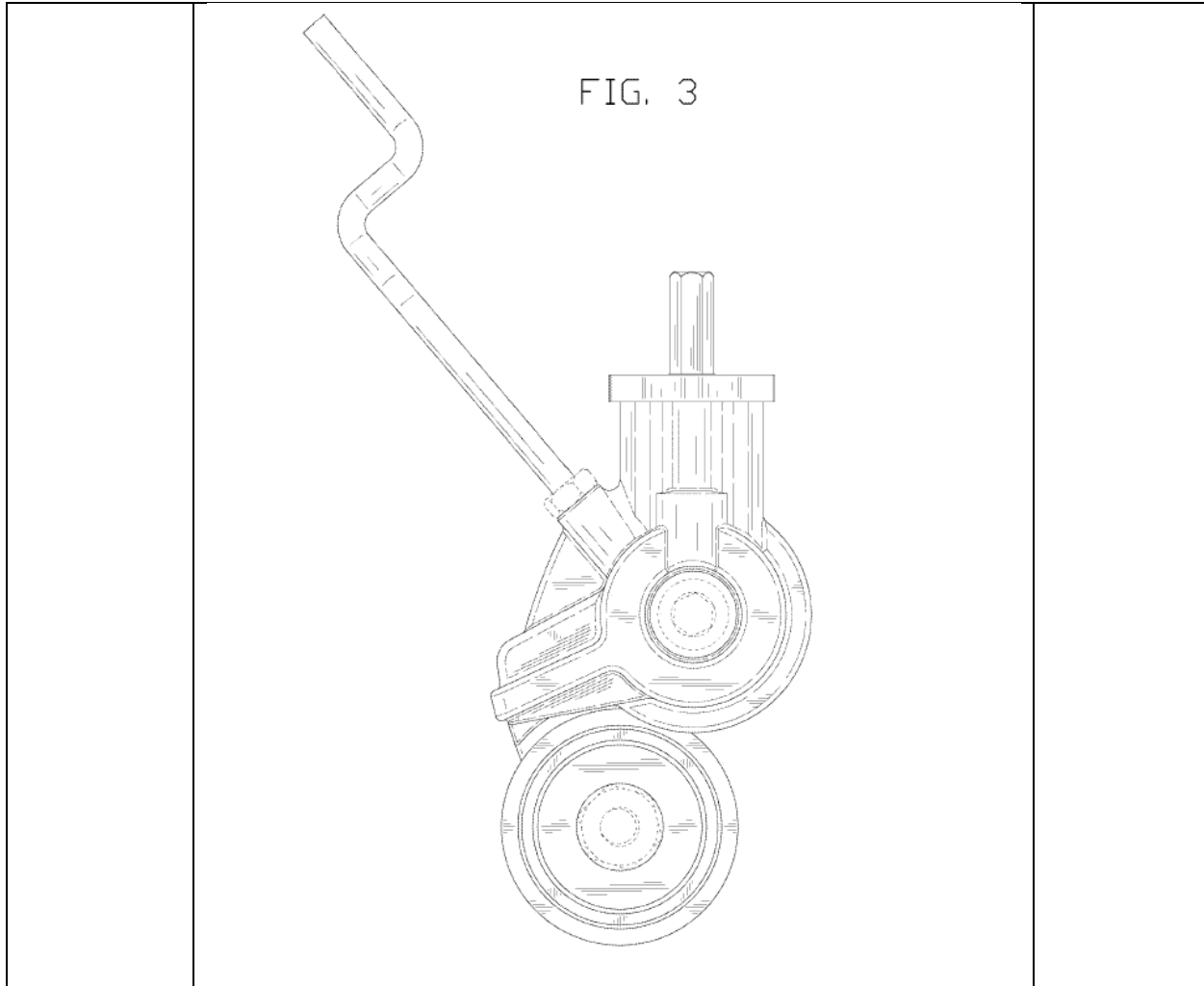
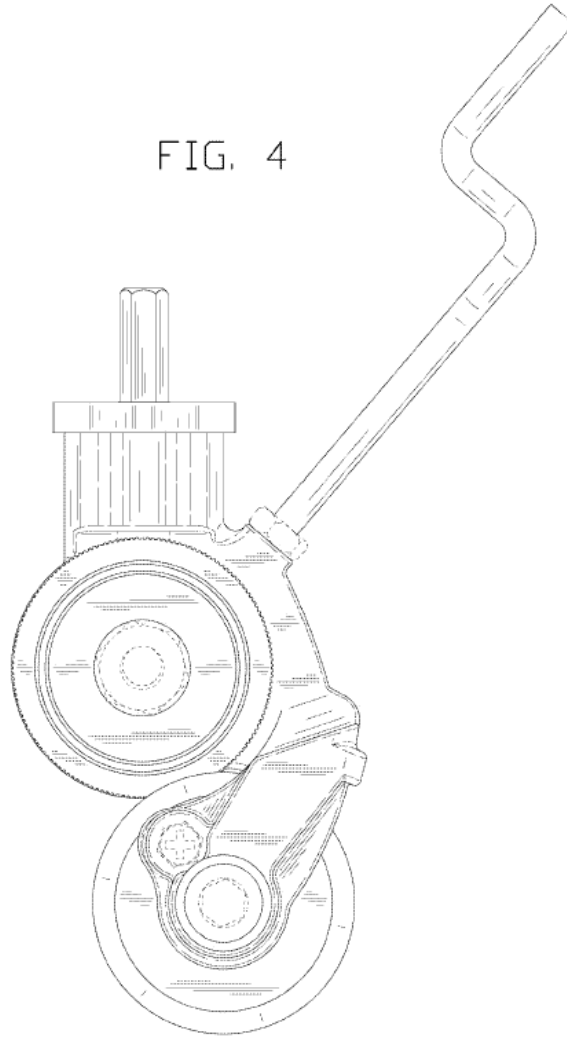

FIG. 4





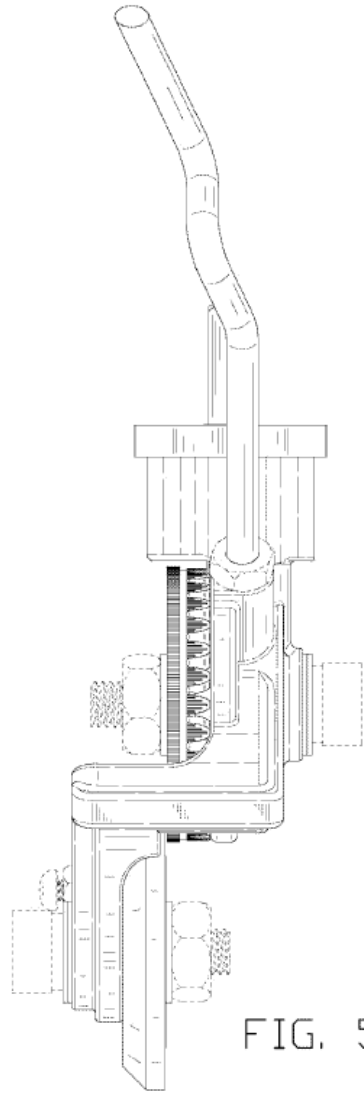
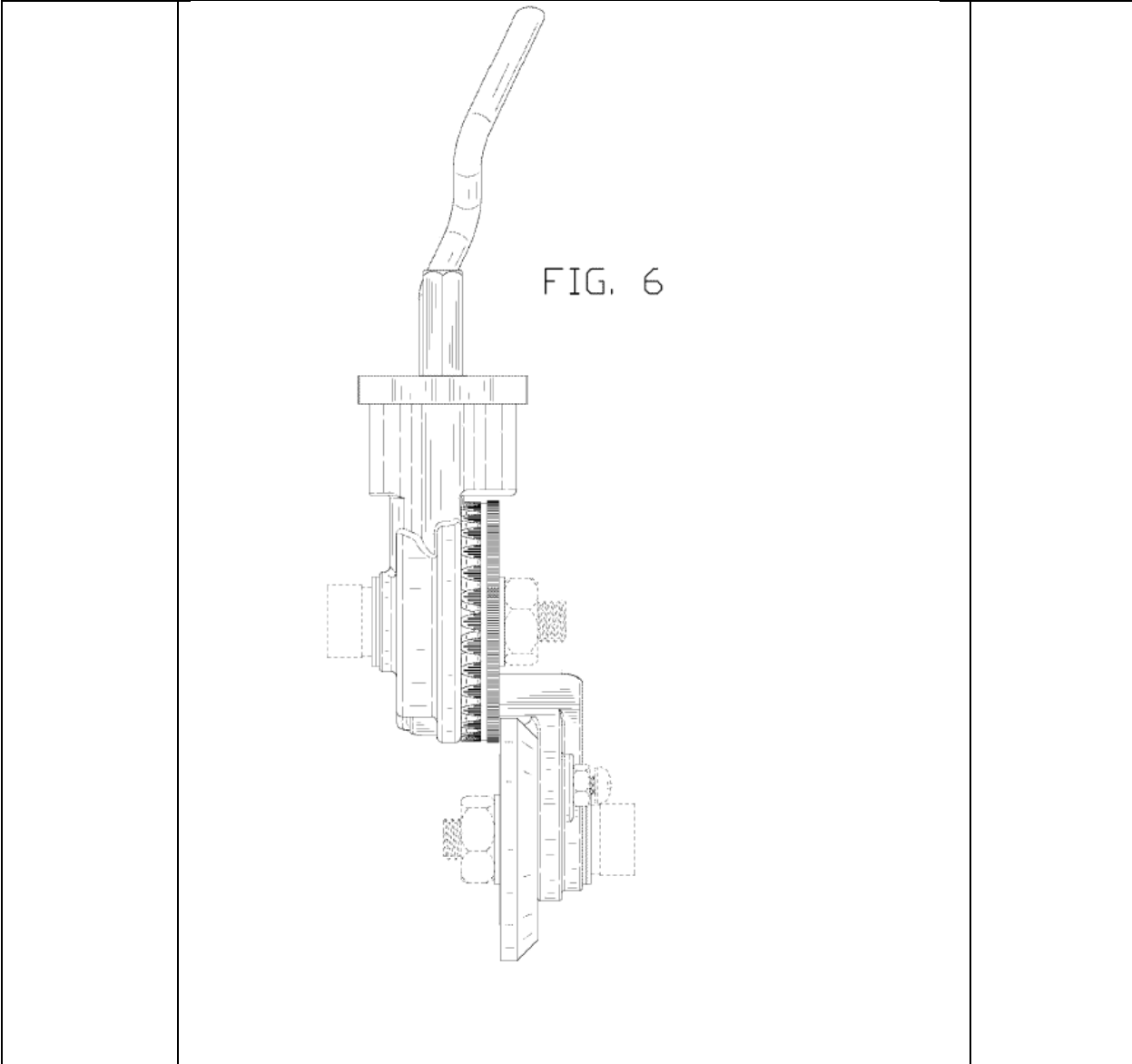

FIG. 5



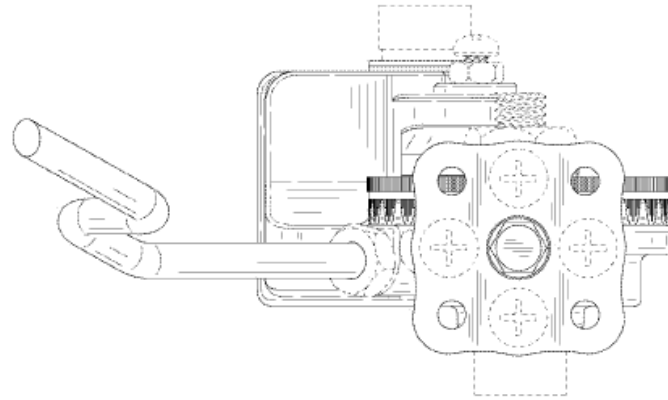

FIG. 7

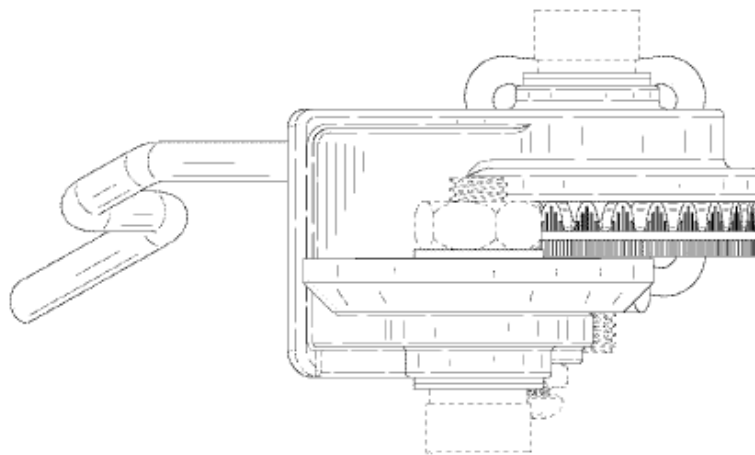

FIG. 8

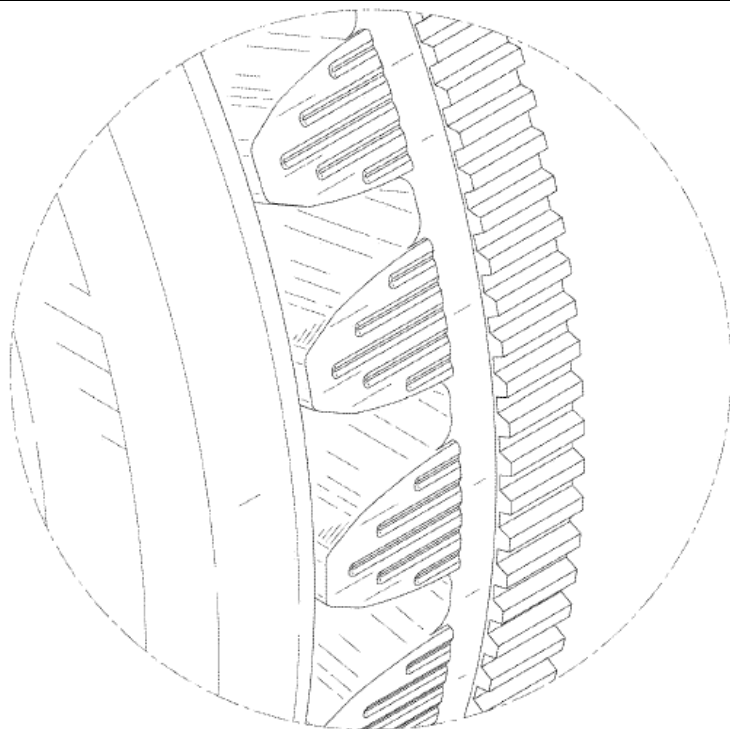
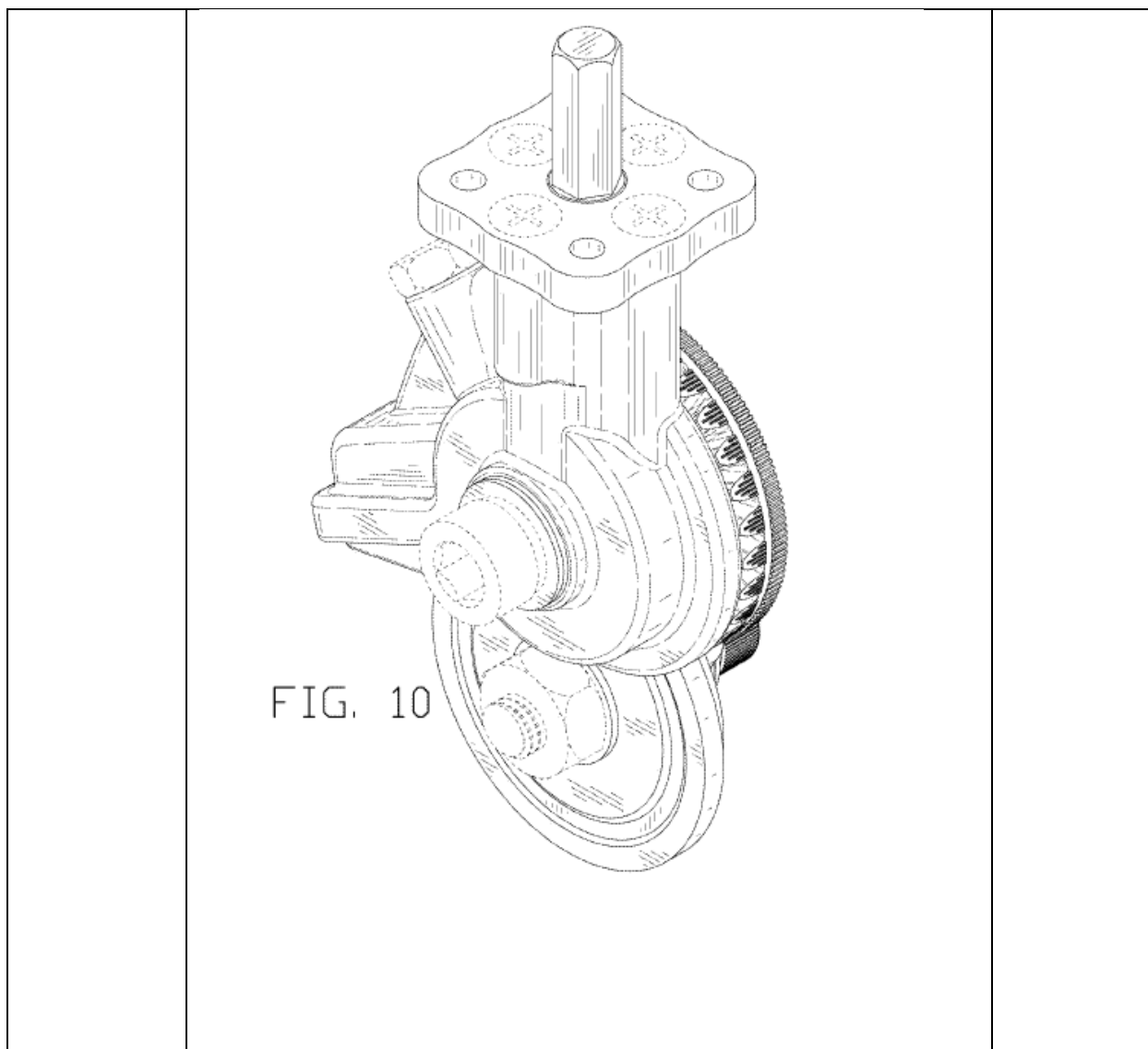

FIG. 9



9. Shunhechuanmei is the lawful assignee of all right, title, and interest in and to the Shunhechuanmei Design. The D1,006,076 patent for the Shunhechuanmei Design was lawfully issued on November 28, 2023, with Qing Jiang as the first named inventor. Attached hereto as Exhibit 2 is a true and correct copy of the United States Patent for the Shunhechuanmei Design.

10. A Petition for Certificate of Correction has been submitted with the United States Patent and Trademark Office (“USPTO”) to add Jiangyong Huang as an inventor.

The USPTO's approval of the Certificates of Correction of inventorship is attached hereto as Exhibit 6.

11. Defendants are individuals and business entities of unknown makeup who own and/or operate one or more of the e-commerce stores under at least the Seller Aliases identified on Schedule A and/or other seller aliases not yet known to Shunhechuanmei. On information and belief, Defendants reside and/or operate in the People's Republic of China or other foreign jurisdictions with lax intellectual property enforcement systems or redistribute products from the same or similar sources in those locations. Defendants have the capacity to be sued pursuant to Federal Rule of Civil Procedure 17(b).

12. On information and belief, Defendants either individually or jointly, operate one or more e-commerce stores under the Seller Aliases listed in Schedule A attached hereto. Tactics used by Defendants to conceal their identities and the full scope of their operation make it virtually impossible for Shunhechuanmei to discover Defendants' true identities and the exact interworking of their network. If Defendants provide additional credible information regarding their identities, Shunhechuanmei will take appropriate steps to amend the Complaint.

### **DEFENDANTS' UNLAWFUL CONDUCT**

13. In recent years, Shunhechuanmei has identified numerous fully interactive, e-commerce stores, including those operating under the Seller Aliases, which were offering for sale and/or selling Infringing Products on online marketplace platforms such as Amazon, eBay, AliExpress, Alibaba, Wish.com, Walmart, Etsy, and DHgate, including the e-commerce stores operating under the Seller Aliases. The Seller Aliases target consumers in this Judicial District and throughout the United States. According to a U.S. Customs

and Border Protection (CBP) Report, in 2021, CBP made over 27,000 seizures of goods with intellectual property rights (IPR) violations totaling over \$3.3 billion, an increase of \$2.0 billion from 2020. Intellectual Property Rights Seizure Statistics, Fiscal Year 2021, U.S. Customs and Border Protection (Exhibit 3). Of the 27,000 in total IPR seizures, over 24,000 came through international mail and express courier services (as opposed to containers), 51 percent of which originated from China and Hong Kong. *Id.*

14. Third party service providers like those used by Defendants do not adequately subject new sellers to verification and confirmation of their identities, allowing infringers to “routinely use false or inaccurate names and addresses when registering with these e-commerce platforms.” Exhibit 4, Daniel C.K. Chow, *Alibaba, Amazon, and Counterfeiting in the Age of the Internet*, 40 NW. J. INT’L L. & BUS. 157, 186 (2020); see also, report on “Combating Trafficking in Counterfeit and Pirated Goods” prepared by the U.S. Department of Homeland Security’s Office of Strategy, Policy, and Plans (Jan. 24, 2020), attached as Exhibit 5 and finding that on “at least some e-commerce platforms, little identifying information is necessary for [an infringer] to begin selling” and recommending that “[s]ignificantly enhanced vetting of third-party sellers” is necessary. Infringers hedge against the risk of being caught and having their websites taken down from an e-commerce platform by preemptively establishing multiple virtual storefronts. Exhibit 5 at p. 22. Since platforms generally do not require a seller on a third-party marketplace to identify the underlying business entity, infringers can have many different profiles that can appear unrelated even though they are commonly owned and operated. Exhibit 5 at p. 39. Further, “E-commerce platforms create bureaucratic or technical hurdles in helping brand owners to locate or identify sources of [infringement].” Exhibit 4 at 186-187.

15. Defendants have targeted sales to Illinois residents by setting up and operating e-commerce stores that target United States consumers using one or more Seller Aliases, offer shipping to the United States, including Illinois, accept payment in U.S. dollars and/or funds from U.S. bank accounts, and, on information and belief, have sold Infringing Products to residents of Illinois.

16. Defendants concurrently employ and benefit from substantially similar advertising and marketing strategies. For example, Defendants facilitate sales by designing e-commerce stores operating under the Seller Aliases so that they appear to unknowing consumers to be authorized online retailers, outlet stores, or wholesalers. E-commerce stores operating under the Seller Aliases appear sophisticated and accept payment in U.S. dollars and/or funds from U.S. bank accounts via credit cards, Alipay, Amazon Pay, eBay, and/or PayPal. E-commerce stores operating under the Seller Aliases often include content and images that make it very difficult for consumers to distinguish such stores from an authorized retailer. Shunhechuanmei has not licensed or authorized Defendants to use the Shunhechuanmei Design, and none of the Defendants are authorized retailers of genuine Shunhechuanmei Products.

17. E-commerce store operators like Defendants commonly engage in fraudulent conduct when registering the Seller Aliases by providing false, misleading and/or incomplete information to e-commerce platforms to prevent discovery of their true identities and the scope of their e-commerce operation.

18. E-commerce store operators like Defendants regularly register or acquire new seller aliases for the purpose of offering for sale and selling Infringing Products. Such seller alias registration patterns are one of many common tactics used by e-commerce



store operators like Defendants to conceal their identities and the full scope and inter-working of their operation, and to avoid being shut down.

19. Even though Defendants operate under multiple fictitious aliases, the e-commerce stores operating under the Seller Aliases often share unique identifiers, such as templates with common design elements that intentionally omit any contact information or other information for identifying Defendants or other Seller Aliases they operate or use. E-commerce stores operating under the Seller Aliases include other notable common features, such as use of the same registration patterns, accepted payment methods, check-out methods, keywords, advertising tactics, similarities in price and quantities, the same incorrect grammar and misspellings, and/or the use of the same text and images. Additionally, Infringing Products for sale by the Seller Aliases bear similar irregularities and indicia of being unauthorized to one another, suggesting that the Infringing Products were manufactured by and come from a common source and that Defendants are inter-related.

20. E-commerce store operators like Defendants are in constant communication with each other and regularly participate in QQ.com chat rooms and through websites such as sellerdefense.cn, kaidianyo.com and kuajingvs.com regarding tactics for operating multiple accounts, evading detection, pending litigation, and potential new lawsuits.

21. Infringers such as Defendants typically operate under multiple seller aliases and payment accounts so that they can continue operation despite Shunhechuanmei's enforcement. E-commerce store operators like Defendants maintain off-shore bank accounts and regularly move funds from their financial accounts to off-shore accounts outside the jurisdiction of this Court to avoid payment of any monetary judgment awarded to

Shunhechuanmei. Indeed, analysis of financial account transaction logs from previous similar cases indicates that off-shore infringers regularly move funds from U.S.-based financial accounts to off-shore accounts outside the jurisdiction of this Court.

22. Defendants are working in active concert to knowingly and willfully manufacture, import, distribute, offer for sale, and sell Infringing Products in the same transaction, occurrence, or series of transactions or occurrences. Defendants, without any authorization or license from Shunhechuanmei, have jointly and severally, knowingly and willfully offered for sale, sold, and/or imported into the United States for subsequent resale or use the same product that infringes directly and/or indirectly the Shunhechuanmei Design. Each e-commerce store operating under the Seller Aliases offers shipping to the United States, including Illinois, and, on information and belief, each Defendant has sold Infringing Products into the United States and Illinois over the Internet.

23. Defendants' infringement of the Shunhechuanmei Design in the making, using, offering for sale, selling, and/or importing into the United States for subsequent sale or use of the Infringing Products was willful.

24. Defendants' infringement of the Shunhechuanmei Design in connection with the making, using, offering for sale, selling, and/or importing into the United States for subsequent sale or use of the Infringing Products, including the making, using, offering for sale, selling, and/or importing into the United States for subsequent sale or use of Infringing Products into Illinois, is irreparably harming Shunhechuanmei.

**COUNT I**  
**PATENT INFRINGEMENT**  
**(35 U.S.C. § 271)**

25. Plaintiff realleges and incorporates by reference the previous paragraphs of this Complaint.

26. Defendants are making, using, offering for sale, selling, and/or importing into the United States for subsequent sale or use Infringing Products that infringe directly and/or indirectly the ornamental design claimed in the Shunhechuanmei Design disclosed and claimed in U.S. Patent No. D1,006,076.

27. Defendants have infringed the Shunhechuanmei Design through the afore-said acts and will continue to do so unless enjoined by this Court. Defendants' wrongful conduct has caused Shunhechuanmei to suffer irreparable harm resulting from the loss of its lawful patent rights to exclude others from making, using, selling, offering for sale, and importing the patented invention. Shunhechuanmei is entitled to injunctive relief pursuant to 35 U.S.C. § 283.

28. Shunhechuanmei is entitled to recover damages adequate to compensate for the infringement, including Defendants' profits pursuant to 35 U.S.C. § 289. Shunhechuanmei is entitled to recover any other damages as appropriate pursuant to 35 U.S.C. § 284.

### **PRAYER FOR RELIEF**

WHEREFORE, Plaintiff respectfully prays that this Court enter judgment against Defendants as follows:

WHEREFORE, Shunhechuanmei prays for judgment against Defendants as follows:

1. That Defendants, their affiliates, officers, agents, servants, employees, attorneys,

confederates, and all persons acting for, with, by, through, under or in active concert with them be temporarily, preliminarily, and permanently enjoined and restrained from:

- a. making, using, offering for sale, selling, and/or importing into the United States for subsequent sale or use the Infringing Product;
  - b. aiding, abetting, contributing to, or otherwise assisting anyone in making, using, offering for sale, selling, and/or importing into the United States for subsequent sale or use the Infringing Product; and
  - c. effecting assignments or transfers, forming new entities or associations or utilizing any other device for the purpose of circumventing or otherwise avoiding the prohibitions set forth in Subparagraphs (a) and (b).
2. Entry of an Order that, upon Shunhechuanmei's request, those with notice of the injunction, including, without limitation, any online marketplace platforms such as eBay, AliExpress, Alibaba, Amazon, Wish.com, Walmart, Etsy, and DHgate (collectively, the "Third Party Providers") shall disable and cease displaying any advertisements used by or associated with Defendants in connection with the sale of the Infringing Product, and take all reasonable steps necessary to prevent links to the Defendant Internet Stores identified on Schedule A from displaying in search results, including, but not limited to, removing links to the Defendant Internet Stores from any search index;
3. That Shunhechuanmei be awarded such damages as it shall prove at trial against Defendants that are adequate to compensate Shunhechuanmei for Defendants'

infringement of the Shunhechuanmei Design, but in no event less than a reasonable royalty for the use made of the invention by the Defendants, together with interest and costs, pursuant to 35 U.S.C. § 284;

4. That the amount of damages awarded to Shunhechuanmei to compensate Shunhechuanmei for infringement of the Shunhechuanmei Design be increased by three times the amount thereof, as provided by 35 U.S.C. § 284;
5. In the alternative, that Shunhechuanmei be awarded all profits realized by Defendants from Defendants' infringement of the Shunhechuanmei Design, but not less than \$250, pursuant to 35 U.S.C. § 289;
6. That Shunhechuanmei be awarded its reasonable attorneys' fees and costs; and
7. Award any and all other relief that this Court deems just and proper.

GUANGDONGSHENG SHUNHECHUANMEI  
CO., LTD.

Date: July 11, 2024

By: /s/ Konrad Sherinian  
An attorney for plaintiff

Attorneys for Plaintiff

Konrad Sherinian  
E-Mail: [ksherinian@sherinianlaw.net](mailto:ksherinian@sherinianlaw.net)  
Depeng Bi  
E-Mail: [ebi@sherinianlaw.net](mailto:ebi@sherinianlaw.net)  
THE LAW OFFICES OF KONRAD SHERINIAN, LLC  
1755 Park Street, Suite # 200  
Naperville, Illinois 60563  
Telephone: (630) 318-2606  
Facsimile: (630) 364-5825