

YK LAW LLP
Jesse Weiner
32 E. 57th Street, 8th Floor
New York, NY 10022

Attorney for Plaintiff
Guichun Qiu

**UNITED STATES DISTRICT COURT
EASTERN DISTRICT OF NEW YORK**

----- X
Guichun Qiu,

Plaintiff,

Civil Action No.:
24-cv-7596

-against-

The Partnerships and
Unincorporated Associations
Identified on Schedule A,

COMPLAINT FOR DESIGN
PATENT INFRINGEMENT,
FALSE DESIGNATION OF
ORIGIN, UNFAIR
COMPETITION AND
UNJUST ENRICHMENT

Defendants.

----- X

Plaintiff Guichun Qiu (the "Plaintiff") by and through its undersigned counsel, pleads the following against Defendants. The Partnerships and Unincorporated Associations Identified on Schedule A (hereinafter "Defendants"), and alleges as follows:

I. THE PARTIES

1. Plaintiff is the owner of record of the U.S. Patent No. D1,016,678 S (the "D'678 Patent", "Exhibit A"), entitled "Electric Bicycle," which was issued on March 5, 2024, from U.S. Patent Application No. 29/848,487 (the "D'487 Application"), filed on August 3, 2022. Plaintiff has been selling the electric bicycle covered by the D'678 Patent in its e-commerce stores to consumers in the United States and those in the State of New York.

2. Defendants are Partnerships and Unincorporated Associations Identified on Schedule A. On information and belief, Defendants are based in China and other foreign countries. Defendants sell, offer for sale their counterfeit products that infringe the D'678 Patent to consumers in the United States and in the State of New York through their e-commerce stores on Amazon.com.

II. JURISDICTION AND VENUE

3. This is an action arising under the patent laws of the United States, 35 U.S.C. § 1 et seq. This Court has subject matter jurisdiction pursuant to 28 U.S.C. §§ 1331 and 1338(a).

4. This Court has personal jurisdiction over Defendants because Defendants have offered for sale, sold, and continue to sell products covered by the D'678 Patent ("Infringing Products") to consumers in this District. Screenshots of the checkout pages

to purchase the Infringing Products from each of the Defendants on Schedule A for shipping to consumers in this District are attached herein (Exhibit B). Further, this Court has personal jurisdiction over the Defendants under Rule 4(k)(2) for their violations of the federal patent law.

5. Venue is proper in this District because Defendants, as foreign corporations, may be sued in any district pursuant to 28 U.S.C. § 1391(c)(3).

III. STATEMENT OF FACTS

6. Plaintiff develops, markets, sells and distributes its patented products under the D'678 Patent. Plaintiff's patented design has been the subject of substantial and continuous marketing and promotion.

7. Plaintiff has and continues to widely market and promote the patented products in the industry and to consumers. By way of example, but not limitation, they are promoted, marketed and sold on Plaintiff's websites, social media sites, and on the Amazon.com platform.

8. Among the purchasing public, Plaintiff's patented products are instantly recognizable, as such, and are known for their distinctive patented design. This design is well recognized by consumers.

9. Plaintiff is the lawful owner of all right, title, and interest in and to the D'678 Patent. Plaintiff has not granted a license or any other form of permission to Defendants to make, use, sell, or offer for sale the patented products disclosed and claimed in the D'678 Patent.'

10. Plaintiff's patented products have a distinctive ornamental design which is unique to Plaintiff. Defendants slavish copying of that design is likely to cause confusion to an ordinary observer, such that such a person may buy a copycat product from one of the Defendants thinking it is sold by the Plaintiff, with its distinctive features and signifying to the purchaser that the products are sold by the Plaintiff and are manufactured to Plaintiff's quality standards. Whether Plaintiff manufactures the products itself or licenses others to do so, Plaintiff has ensured that products bearing its patented design are manufactured to the highest quality standards. As such, the goodwill associated with the patented products is incalculable and of inestimable value to Plaintiff.

11. Plaintiff has expended substantial time, money, and other resources in developing, advertising, and otherwise promoting its patented products. As a result, products bearing the patented design are widely recognized and exclusively

associated by consumers, the public and the trade as being products sourced from Plaintiff.

12. Defendants are individuals and business entities who, upon information and belief, reside primarily in the People's Republic of China or other foreign jurisdictions. Defendants conduct business throughout the United States, including within New York and in this District, through the operation of fully interactive e-commerce stores on Amazon.com. Each Defendant targets the United States, including the district of New York, and has offered to sell and, on information and belief, has sold and continues to sell Infringing Products to consumers within the United States, including in New York and in this District. The Infringing Products from each Defendant are compared directly with the claimed design in the D'678 Patent (Exhibit C).

13. The success of the sale of the patented products by the Defendants has resulted in its infringement. Plaintiff has identified numerous e-commerce stores on Amazon.com, including the Defendants' e-commerce stores, which were offering for sale, selling, and importing Infringing Products to consumers in this District and throughout the United States.

14. According to an Intellectual Property Rights Seizures Statistics Report issued by the Department of Homeland Security,

the manufacturer's suggested retail price (MSRP) of goods seized by the U.S. government in fiscal year 2017 was over \$1.2 billion. Internet websites like the Defendants' e-commerce stores are also estimated to contribute to tens of thousands of lost jobs for legitimate businesses and broader economic damages such as lost tax revenue every year.

15. Upon information and belief, Defendants facilitate sales by designing their e-commerce stores so that they appear to unknowing consumers to be authorized online retailers, outlet stores, or wholesalers selling genuine products patented by the Plaintiff. Many of the Defendants' e-commerce stores look sophisticated and accept payment in U.S. dollars via credit cards, eBay, Wish, Amazon, Alipay, Alibaba, Walmart and Joom. Defendants' e-commerce stores often include images and design elements that make it very difficult for consumers to distinguish such infringing sites from an authorized website. Defendants further perpetuate the illusion of legitimacy by offering "live 24/7" customer service and using indicia of authenticity and security that consumers have come to associate with authorized retailers, including the McAfee® Security, VeriSign®, Visa®, MasterCard®, and PayPal® logos.

16. Plaintiff has not licensed or authorized Defendants to use the D'678 Patent, and none of the Defendants is an authorized retailer of genuine products patented by the Plaintiff.

17. Upon information and belief, Defendants also deceive unknowing consumers by using the design of the D'678 Patent without authorization within the content, text, and/or meta tags of their websites to attract various search engines crawling the Internet looking for websites relevant to consumer searches for products patented by Plaintiff. Additionally, upon information and belief, Defendants use other unauthorized search engine optimization (SEO) tactics and social media spamming so that the Defendants' e-commerce stores listings show up at or near the top of relevant search results and misdirect consumers searching for genuine products patented and sold by Plaintiff.

18. Defendants go to great lengths to conceal their identities and often use multiple fictitious names and addresses to register and operate their massive network of Defendants' e-commerce stores. For example, many of Defendants' names and physical addresses used to register the Defendants' e-commerce stores are incomplete, contain randomly typed letters, or fail to include cities or states. Other Defendants' e-commerce stores use privacy services that conceal the owners' identity and contact information. Upon information and belief, Defendants regularly create new websites and online marketplace accounts on various platforms using the identities listed in Schedule A to the Complaint, as well as other unknown fictitious names and addresses.

Defendants' e-commerce store registration patterns are one of many common tactics used by the Defendants to conceal their identities, the full scope and interworking of their massive infringing operation, and to avoid being shut down.

19. Even though Defendants operate under multiple fictitious names, there are numerous similarities among the Defendant e-commerce stores. For example, some of the Defendants' websites have virtually identical layouts, even though different aliases were used to register the respective domain names. In addition, the Infringing Products for sale in the Defendants' e-commerce stores bear similarities and indicia of being related to one another, suggesting that the Infringing Products were manufactured by and come from a common source and that, upon information and belief, Defendants are interrelated. The Defendant e-commerce stores also include other notable common features, including use of the same domain name registration patterns, unique shopping cart platforms, accepted payment methods, check-out methods, meta data, illegitimate SEO tactics, HTML user-defined variables, domain redirection, lack of contact information, identically or similarly priced items and volume sales discounts, similar hosting services, similar name servers, and the use of the same text and images.

20. In addition to operating under multiple fictitious names, Defendants in this case and defendants in other similar cases against online infringers use a variety of other common tactics to evade enforcement efforts. For example, infringers like Defendants will often register new domain names or online marketplace accounts under new aliases once they receive notice of a lawsuit. Infringers also often move website hosting to rogue servers located outside the United States once notice of a lawsuit is received. Rogue servers are notorious for ignoring take down demands sent by brand owners. Infringers also typically ship products in small quantities via international mail to minimize detection by U.S. Customs and Border Protection. A 2012 U.S. Customs and Border Protection report on seizure statistics indicated that the Internet has fueled "explosive growth" in the number of small packages of infringing goods shipped through the mail and express carriers.

21. Further, infringers such as Defendants typically operate multiple credit card merchant accounts and eBay, Wish, Amazon, Alipay, Alibaba, Walmart and Joom accounts behind layers of payment gateways so that they can continue operation despite Plaintiff's enforcement efforts. Upon information and belief, Defendants maintain off-shore bank accounts and regularly move funds from their eBay, Wish, Amazon, Alipay, Alibaba, Walmart and Joom

accounts to off-shore bank accounts outside the jurisdiction of this Court. Indeed, analysis of eBay, Wish, Amazon, Alipay, Alibaba, Walmart and Joom transaction logs from previous similar cases indicates that offshore infringers regularly move funds from U.S.-based eBay, Wish, Amazon, Alipay, Alibaba, Walmart and Joom accounts to China-based bank accounts outside the jurisdiction of this Court.

22. Defendants, without any authorization or license from Plaintiff, have knowingly and willfully used and continue to use the D'678 Patent in connection with the advertisement, distribution, offering for sale, and sale of Infringing Products into the United States and New York over the Internet. Each Defendant's e-commerce store offers shipping to the United States, including to the State of New York and, on information and belief, each Defendant has offered to sell and has sold Infringing Products into the United States, including the State of New York.

23. Defendants' use of the D'678 Patent in connection with the advertising, distribution, offering for sale, and sale of Infringing Products into the State of New York, is likely to cause and has caused confusion, mistake, and deception by and among consumers and is irreparably harming Plaintiff.

24. The Defendants create numerous Defendant E-commerce stores on Amazon.com to sell and offer for sale Infringing Products and design them to appear to be selling genuine Plaintiff's products, while selling inferior imitations of Plaintiff's authorized products. The Defendants' e-commerce stores share unique identifiers, such as design elements and similarities of the Infringing Products offered for sale, establishing a logical relationship between them, and suggesting that Defendants' illegal operations arise out of the same transaction, occurrence, or series of transactions or occurrences. Defendants attempt to avoid liability by going to great lengths to conceal both their identities and the full scope and interworking of their illegal infringing operation. Plaintiff is forced to file this action to combat Defendants' infringement of the D'678 Patent, and to protect unknowing consumers from purchasing unauthorized products over the Internet. Plaintiff has been and continues to be irreparably damaged by infringement of its valuable Patented Design by Defendants and seeks injunctive and monetary relief.

25. This Court has personal jurisdiction over each Defendant, in that each Defendant conducts business in New York and in this District, and the acts and events giving rise to this lawsuit of which each Defendant stands accused were undertaken in

New York and in this District. In addition, each Defendant has offered to sell and ship Infringing Products into this District.

26. Each of the Defendants offered for sale or sold Infringing Products, through the links identified in Schedule A in the U.S. and in the State of New York.

COUNT I. INFRINGEMENT OF UNITED STATES DESIGN PATENT (35 U.S.C. § 271)

27. Plaintiff repeats and incorporates by reference herein the allegations in paragraphs above.

28. Defendants are making, using, offering for sale, selling, and/or importing into the United States for subsequent sale or use products that infringe directly and/or indirectly the ornamental design claimed in the D'678 Patent.

29. Defendants have infringed the D'678 Patent through the aforesaid acts and will continue to do so unless enjoined by this Court. Defendants' wrongful conduct has caused Plaintiff to suffer irreparable harm resulting from the loss of its lawful patent rights to exclude others from making, using, selling, offering for sale, and importing the patented invention. Plaintiff is entitled to injunctive relief pursuant to 35 U.S.C. § 283.

30. Plaintiff is entitled to recover damages adequate to compensate for the infringement, including Defendants' profits

pursuant to 35 U.S.C. § 289. Plaintiff is entitled to recover any other damages as appropriate pursuant to 35 U.S.C. § 284.

PRAYER FOR RELIEF

WHEREFORE, Plaintiff prays for judgment against Defendants and each of them as follows:

1) That Defendants, their affiliates, officers, agents, servants, employees, attorneys, and all persons acting for, with, by, through, under, or in active concert with them be temporarily preliminarily, and permanently enjoined and restrained from:

a. using the D'678 Patent or any reproductions, infringing copies, or colorable imitations thereof in any manner in connection with the distribution, marketing, advertising, offering for sale, or sale of any products that are not genuine products from the Plaintiff or are not authorized by Plaintiff;

b. passing off, inducing, or enabling others to sell or pass off any products as genuine products covered by the D'678 Patent or any other products produced by Plaintiff that are not Plaintiff's or not produced under the authorization, control, or supervision of Plaintiff and approved by Plaintiff for sale;

c. committing any acts calculated to cause consumers to believe that Defendants' Infringing Products are those sold under

the authorization, control, or supervision of Plaintiff, or are sponsored by, approved by, or otherwise connected with Plaintiff;

d. further infringing the D'678 Patent and damaging Plaintiff's goodwill;

e. shipping, delivering, holding for sale, transferring or otherwise moving, storing, distributing, returning, or otherwise disposing of, in any manner, products or inventory not manufactured by or for Plaintiff, nor authorized by Plaintiff to be sold or offered for sale, and which bear any Patented Design of Plaintiff, or any reproductions, infringing copies, or colorable imitations thereof;

f. using, linking to, transferring, selling, exercising control over, or otherwise owning the Online Marketplace Accounts, the Defendant Domain Names, or any other domain name or online marketplace account that is being used to sell or is the means by which Defendants could continue to sell Infringing Products; and

g. operating and/or hosting websites at the Defendant Domain Names and any other domain names registered or operated by Defendants that are involved with the distribution, marketing, advertising, offering for sale, or sale of any product covered by the D'678 Patent or any reproduction, infringing copy or colorable imitation thereof that is not a genuine product covered by the D'678 Patent or is not authorized by Plaintiff.

2) That Defendants, within fourteen (14) days after service of judgment with notice of entry thereof upon them, be required to file with the Court and serve upon Plaintiff a written report under oath setting forth in detail the manner and form in which Defendants have complied with paragraph 1, a through g, above;

3) Entry of an Order that, at Plaintiff's choosing, the host of Defendants e-commerce stores, including, but not limited to, Amazon.com shall disable the Defendant's e-commerce stores and make them inactive and untransferable;

4) Entry of an Order that, upon Plaintiff's request, those in privity with Defendants and those with notice of the injunction, including any online marketplaces such as Amazon.com, web hosts for the Defendants' domain names, and domain name registrars, shall:

a. disable and cease providing services for any accounts through which Defendants engage in the sale of bicycles which infringe the D'678 Patent, including any accounts associated with the Defendants listed in Schedule A;

b. disable and cease displaying any advertisements used by or associated with Defendants in connection with the sale of Infringing Products; and

c. take all steps necessary to prevent links to the Defendants' e-commerce stores identified in Schedule A from

displaying in search results, including, but not limited to, removing links to the Defendants' e-commerce stores from any search index.

5) That the amount of damages awarded to Plaintiff to compensate Plaintiff for infringement of the D'678 Patent be increased by three times the amount thereof, as provided by 35 U.S.C. § 284;

6) In the alternative, that Plaintiff be awarded all profits realized by Defendants from Defendants' infringement of the D'678 Patent pursuant to 35 U.S.C. § 289;

7) That Plaintiff be awarded its reasonable attorneys' fees and costs; and

8) Award any and all other relief that this Court deems just and equitable.

Dated: **October 30, 2024**

Respectfully submitted,

/S/Jesse Weiner

Jesse Weiner

YK LAW LLP
Jesse Weiner
32 E. 57th Street, 8th Floor
New York, NY 10022

Attorney for Plaintiff
Guichun Qiu

SCHEDULE A

Defendant #	Seller Name	Seller Store ID	Seller Product ID
#1	Riding'times DIRECT	AEGDE9MPHD0FO	B0C4L5J1TQ
#2	Kaijian Mo	A3GAZ84XSJD6OK	B0CJJQTK3S
#3	Riding'times Shop	A3LY3N1O2WMUBZ	B0C9C88F39
#4	Bootime Direct	AA6QQHXL5LC3	B0CLCJ6HH1
#5	SAMBATON	A1BRIPMT50TUA4	B0CHMD95F9
#6	APIWO(US warehouse delivery)	A1RJW4TRW3YB30	B0BXCPIJWL
#7	VNUVCOE Store	A1IPK4M34B9YIQ	B0C1ZC3MM5
#8	KISTP	101124579	2410276526
#9	GYROOR	101079545	3358142152
#10	Big fish Ebike	634418216576117	601099606298288
#11	Big fish Ebike	634418216576117	601099605363807
#12	COONY eBike	634418216784366	601099611824606
#13	Aiken Ebike	634418216522801	601099608895671
#14	Scooter Electric	634418214968767	601099581104238
#15	Aromei	635517727901247	602470814218836
#16	LEEHE Ebike	634418217058170	601099619916789
#17	Huaao Time	634418215711094	601099637180937
#18	Aizepa ebike	634418213801373	601099585564231
#19	movcan shop	634418216732848	601099607510736
#20	ketelesebike	634418214507677	601099649773867
#21	KETELESEBIKEUS	635517728905165	602440749409983
#22	AMYET EBIKE	634418214925736	601099570451250

#23	ceilingLED	/	266746970298
#24	ceilingLED	/	266746978165
#25	KETELES	/	405192441584
#26	KAIJIELAISI	/	226317754944
#27	keteles- EbikeStore	/	315688949136

EXHIBIT A



(12) **United States Design Patent** (10) **Patent No.:** **US D1,016,678 S**
Qiu (45) **Date of Patent:** **** Mar. 5, 2024**

(54) **ELECTRIC BICYCLE**
 (71) Applicant: **Idpoo (Wuxi) Intelligent Technology Co., Ltd., Wuxi (CN)**
 (72) Inventor: **Guichun Qiu, Wuxi (CN)**
 (73) Assignee: **Idpoo (Wuxi) Intelligent Technology Co., Ltd., Wuxi (CN)**
 (**) Term: **15 Years**
 (21) Appl. No.: **29/848,487**

D940,600 S * 1/2022 Chambers D12/117
 D949,062 S * 4/2022 Chambers D13/103
 D979,458 S * 2/2023 Melton D12/110
 D999,115 S * 9/2023 Kikawa D12/111
 2010/0078249 A1 * 4/2010 Nishiura B62M 7/12
 180/220
 2011/0139531 A1 * 6/2011 Kanno B62K 25/283
 180/220
 2013/0270022 A1 * 10/2013 Matsuda B62K 11/04
 180/220
 2014/0305729 A1 * 10/2014 Testoni B62J 43/16
 180/220
 2016/0318577 A1 * 11/2016 Hayslett F16H 63/50

(22) Filed: **Aug. 3, 2022**
 (51) **LOC (14) Cl.** **12-11**
 (52) **U.S. Cl.**
 USPC **D12/111**
 (58) **Field of Classification Search**
 USPC D12/111, 117; D21/412, 414, 419,
 D21/423-428, 431-435
 CPC ... B62K 3/00; B62K 3/02; B62K 3/06; B62K
 11/00; B62K 11/02; B62K 11/04; B62K
 11/10; B62K 17/00; B62K 19/00; B62K
 2202/00
 See application file for complete search history.

OTHER PUBLICATIONS

“Idpoo Ebike for Adults, Max 1500W Retro Electric Bike, Up to 28MPH & 75 Miles Mountain Commuting Electric Bike, . . . Removable Battery.” Amazon., May 23, 2022 [online], [retrieved on Oct. 24, 2023]. Retrieved from the Internet <URL: <https://www.amazon.com/Electric-Mountain-Commuting-Absorbers-Removable/dp/BOBHLDVZSP>>.*

(Continued)

Primary Examiner — Darlington Ly
 (74) *Attorney, Agent, or Firm* — Nitin Kaushik

(56) **References Cited**

U.S. PATENT DOCUMENTS

D432,952 S * 10/2000 Scruggs D12/110
 D643,783 S * 8/2011 Thackery D12/110
 D645,791 S * 9/2011 Lee D12/110
 D803,103 S * 11/2017 Clyde D12/110
 D815,991 S * 4/2018 Clyde D12/110
 D910,496 S * 2/2021 Zhu D12/111
 D915,244 S * 4/2021 Chen D12/111
 D920,848 S * 6/2021 Kuehne D12/110
 D921,539 S * 6/2021 Chambers D12/117
 D924,735 S * 7/2021 Chambers D12/118
 D934,737 S * 11/2021 Chambers D12/110
 D939,387 S * 12/2021 Chambers D12/111
 D940,599 S * 1/2022 Chambers D12/110

DESCRIPTION

FIG. 1 is a front and left side perspective view of an electric bicycle embodying my new design;
 FIG. 2 is a front elevation view thereof;
 FIG. 3 is a rear elevation view thereof;
 FIG. 4 is a right side elevation view thereof;
 FIG. 5 is a left side elevation view thereof;
 FIG. 6 is a top plan view thereof; and,
 FIG. 7 is a bottom plan view thereof.

1 Claim, 7 Drawing Sheets

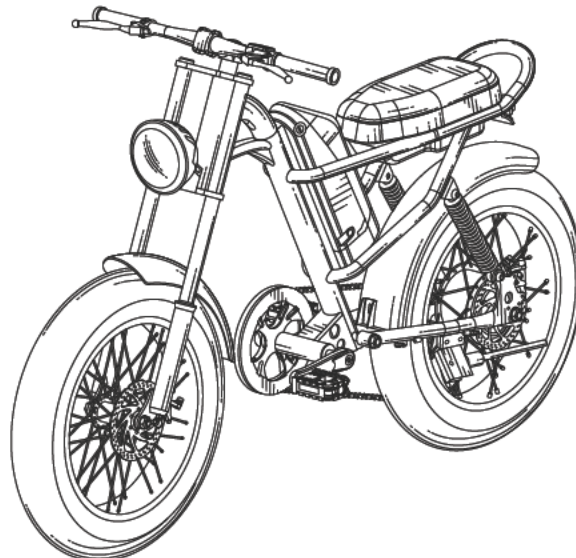

US D1,016,678 S

Page 2

(56) **References Cited**

OTHER PUBLICATIONS

“Zbzo Electric Bike Fat Tire Electric Bicycle 20”x4.0” Ebike for Adults 1000W with Removable 48V Battery, . . . Commuting Mountain Ebike.” Amazon., Mar. 1, 2023 [online], [retrieved on Oct. 24, 2023]. Retrieved from the Internet <URL: <https://www.amazon.com/ZBZO-Electric-Bike-Suspension-Mountain/dp/B0BX62VJDC?th=1>>.*

“Tamobyke Electric Bike,750W/1000W Motor,48V15Ah/30Ah Removable Battery Ebike, . . . Steering Light.” Amazon., May 15, 2023 [online], [retrieved on Oct. 24, 2023]. Retrieved from the Internet <URL: <https://www.amazon.com/Tamobyke-Electric-Removable-Bicycles-Hydraulic/dp/B0C534BXB5?th=1>>.*

“Idpoo IM-J1 Powerful 500W Electric Bike With Long-Range 48V/15AH Battery.” Ebikesz., Aug. 3, 2023 [online], [retrieved on Oct. 24, 2023]. Retrieved from the Internet <URL: <https://www.ebikesz.com/products/idpoo-im-j1-powerful-500w-electric-bike-with-long-range-48v-15ah-battery>>.*

“Riding’ times Z8 Electric Bike 20*4.0 inch Chaoyang Fat Tire . . . Disc Brake Shimano 7-Speed.” Geek Buying., Jun. 8, 2023 [online], [retrieved on Oct. 24, 2023]. Retrieved from the Internet <URL: <https://www.geekbuying.com/item/Riding-times-Z8-Electric-Bike-20-Inch-28MPH-Speed-48V-15Ah-500W-Motor-518044.html>>.*

“Samebike Pilot SR, Black.” Same Bike., Jun. 9, 2023 [online], [retrieved on Oct. 24, 2023]. Retrieved from the Internet <URL: <https://samebikeus.com/products/samebike-pilot-sr-black>>.*

* cited by examiner

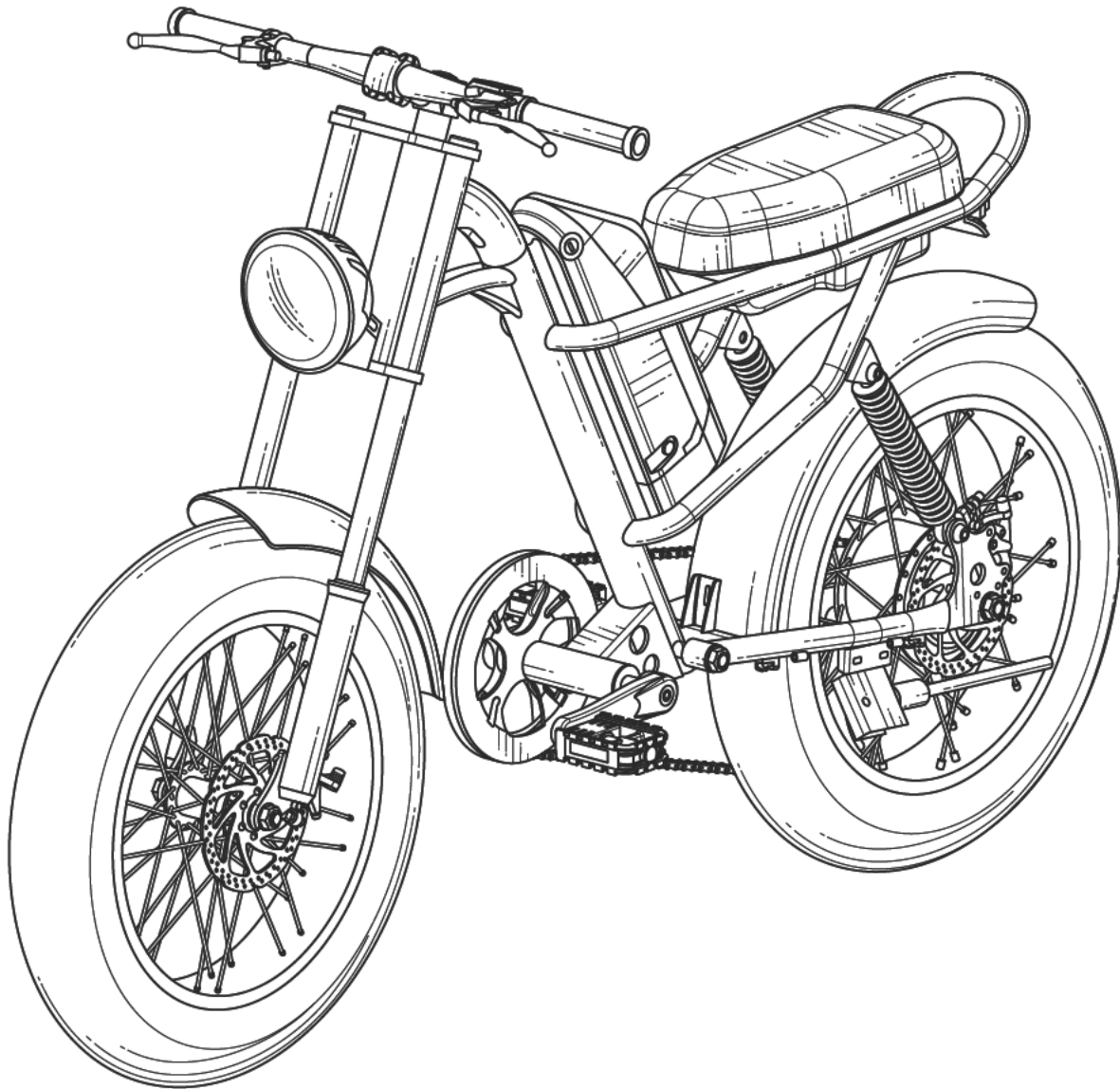

FIG. 1

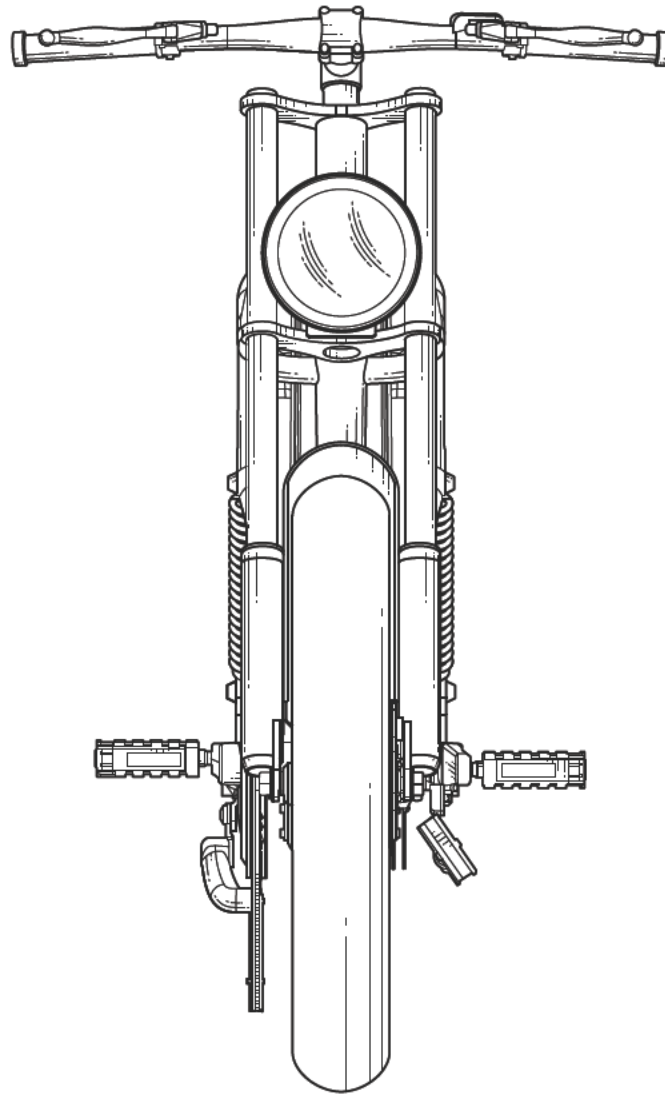

FIG. 2

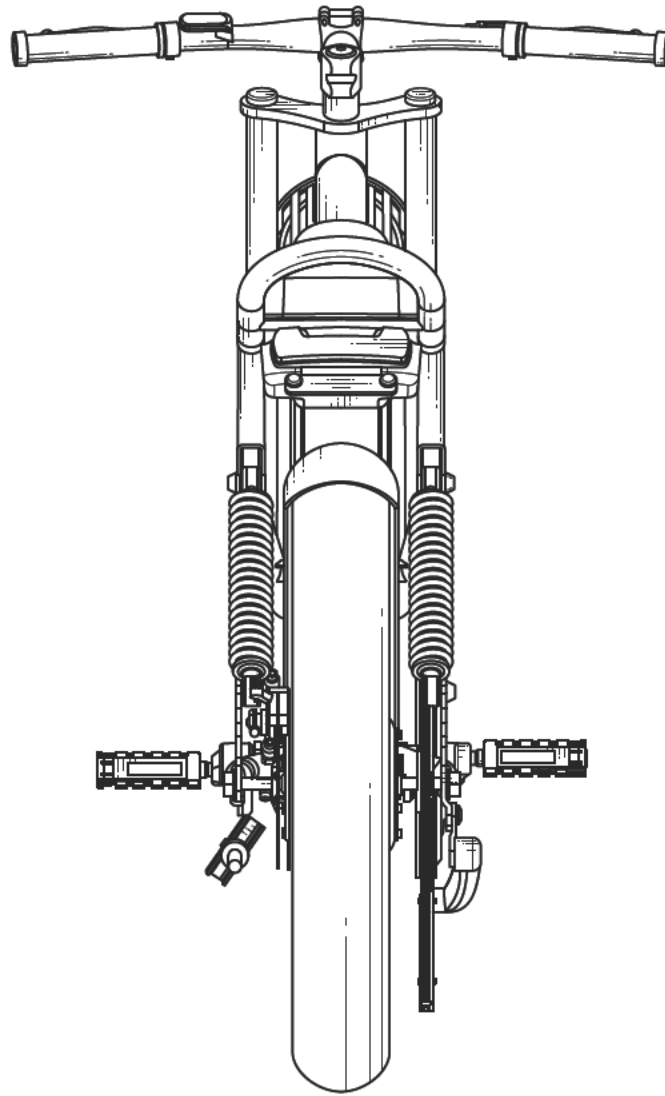

FIG. 3

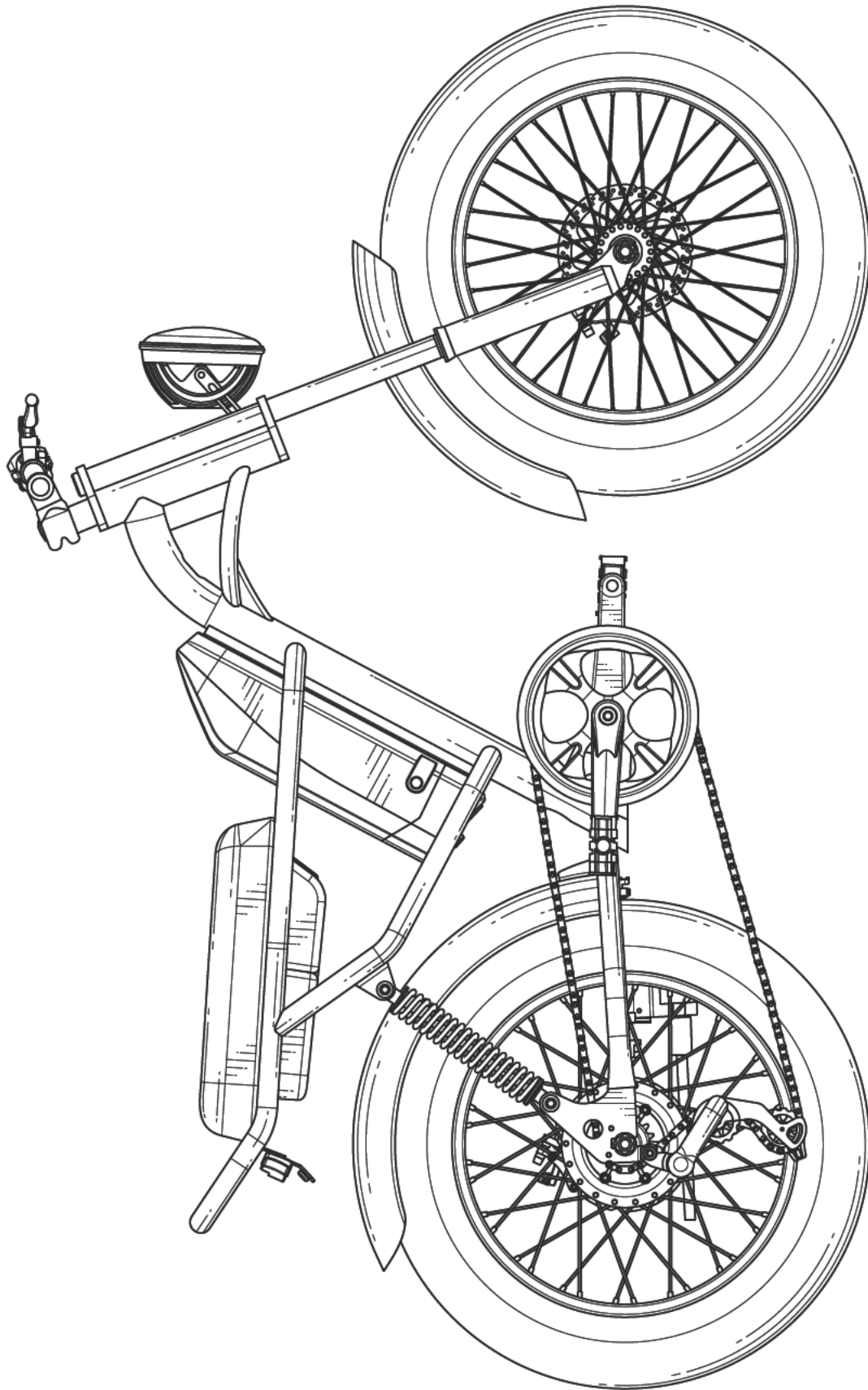

FIG. 4

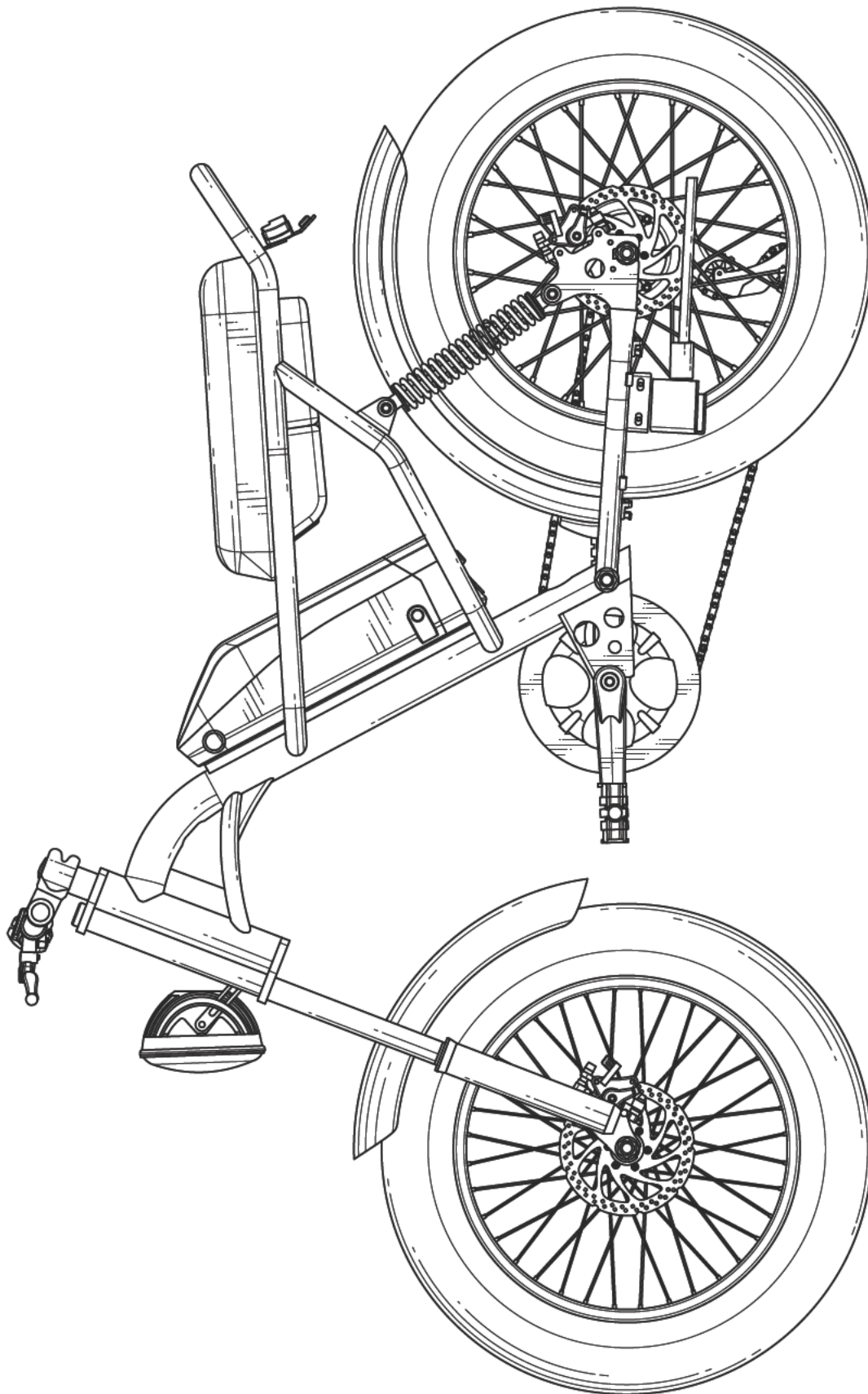

FIG. 5

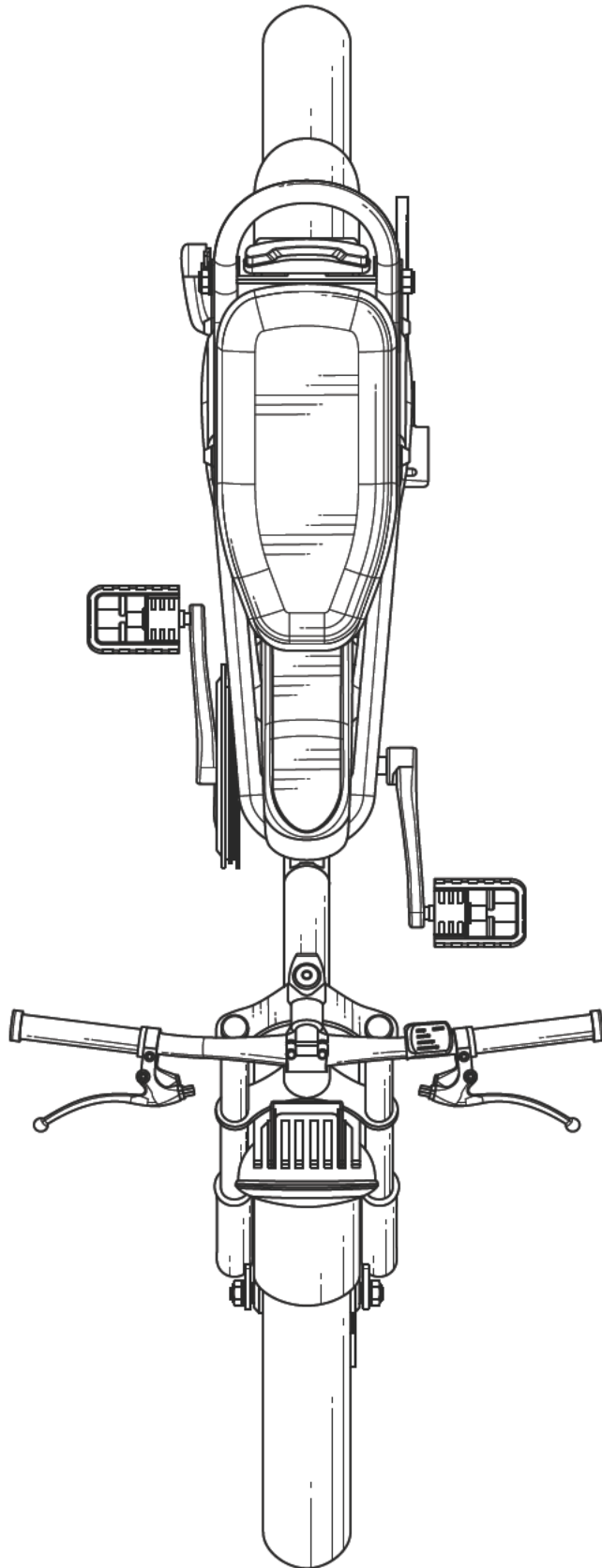

FIG. 6

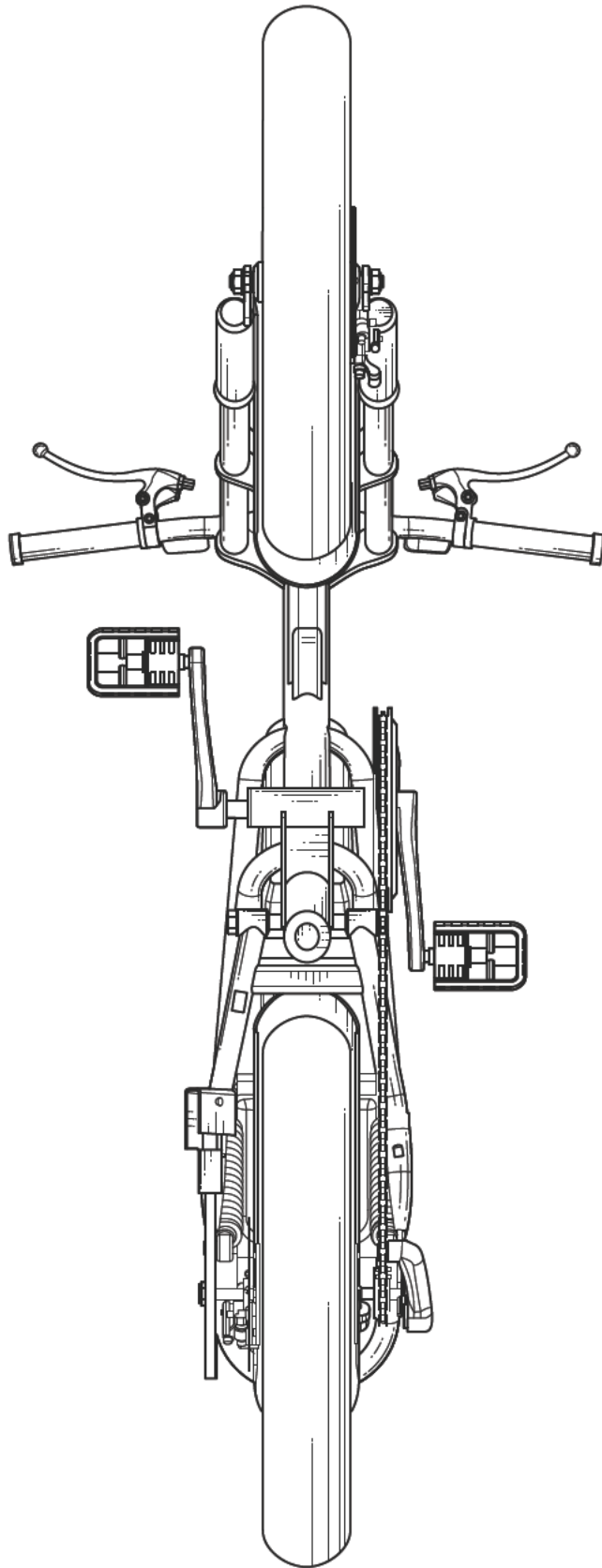

FIG. 7

EXHIBIT B

amazon Checkout (1 item)

1 Shipping address Change
Song Lin
451 W HURON ST UNIT 1505
CHICAGO, IL 60654-3445
[Add delivery instructions](#)

2 Choose a payment method Change

\$50 Amazon Gift Card **Wendy, pay \$992.24 \$942.24 for this order with a \$50 Amazon Gift Card** instantly upon approval. [Find out how](#)

Your credit and debit cards
+ [Add a credit or debit card](#) Amazon accepts all major credit cards.

Payment plans
 Pay over time with Affirm
Apply as part of checkout with just a few pieces of info. [Learn more](#)

Your available balance
+ [Enter a gift card, voucher or promotional code](#)
Enter Code

Other payment methods
+ [Learn more about Amazon Store Card](#) Access to exclusive financing offers. No annual fee. Zero fraud liability.
+ [Add a personal checking account](#)
Use your US based personal checking account. [Learn more](#)

[Use this payment method](#)

Order Summary
Items: \$899.99
Shipping & handling: \$0.00
Total before tax: \$899.99
Estimated tax to be collected*: \$92.25
Order total: \$992.24

[How are shipping costs calculated?](#)

amazon Checkout (1 item)

1 Shipping address Change
Song Lin
451 W HURON ST UNIT 1505
CHICAGO, IL 60654-3445
[Add delivery instructions](#)

2 Payment method Change
Pay over time with Affirm
+ [Add a gift card or promotion code or voucher](#)
Enter code

3 Offers

4 Review items and shipping

Arriving Sep 10, 2024 - Sep 13, 2024
Items shipped from Kalljan Mo

Dadid 1500W Electric Bike for Adults, 48V/15.6Ah Removable Battery, 6 Layer Full Suspension/20" Fat Tire Electric Bicycles, 28MPH/75Miles Range/7 Speed Gears, Beach Mountain Road Bike
\$899.99
Qty: 1
Sold by: Kalljan Mo
Gift options not available

Choose a delivery option:
 Tuesday, Sep 10 - Friday, Sep 13
FREE Delivery

Order total: \$992.24
By clicking or tapping Continue to Application, you agree to Amazon's [privacy notice](#) and [conditions of use](#).
You have selected to pay over time with Affirm, and you will need to submit an application for financing with a third party. We will share information about you, and your Amazon.com account, and this purchase transaction to assist Affirm in evaluating your finance application, and the detection and prevention of fraud.

[Continue to application](#)

Order Summary
Items: \$899.99
Shipping & handling: \$0.00
Total before tax: \$899.99
Estimated tax to be collected*: \$92.25
Order total: \$992.24

[How are shipping costs calculated?](#)

*Why has sales tax been applied? [See tax and seller information.](#)
Need help? Check our [help pages](#) or [contact us](#).

amazon Checkout (1 item)

1 Shipping address Change
Song Lin
451 W HURON ST UNIT 1505
CHICAGO, IL 60654-3445
[Add delivery instructions](#)

2 Payment method Change
Payment plan selected
Add a gift card or promotion code or voucher
Enter code

3 Offers

4 Items and shipping Change
Estimated delivery: Sept. 11, 2024 - Sept. 16, 2024
 RidingTimes 1500W Electric Bike with 20" x 4 inch Fat Tire, 6 Layer Full Suspension Retro Off Road Ebike, 15.6AH Removable Battery Up to 28MPH & 75Miles, Mountain Winter Snow Electric Bike

Next Step
Sign up for Prime or select "Not right now" to continue checking out. You'll still have a chance to review and edit your order before it's final.

Order Summary
Items: \$949.99
Shipping & handling: \$0.00
Total before tax: \$949.99
Estimated tax to be collected*: \$97.37
Order total: \$1,047.36

[How are shipping costs calculated?](#)

*Why has sales tax been applied? [See tax and seller information.](#)
Need help? Check our [help pages](#) or [contact us](#).
For an item sold by Amazon.com: When you click the "Place your order" button, we'll send you an email message acknowledging receipt of your order. Your contract to purchase an item will not be complete until we send you an email notifying you that the item has been shipped.
[Important information about sales tax you may owe in your state](#)
You may return new, unopened merchandise in original condition within 30 days of delivery. Exceptions and restrictions apply. See Amazon.com's [Returns Policy](#).
Need to add more items to your order? Continue shopping on the [Amazon.com homepage](#).

amazon Checkout (1 item)

1 Shipping address Change
Song Lin
451 W HURON ST UNIT 1505
CHICAGO, IL 60654-3445
[Add delivery instructions](#)

2 Special delivery options Change
Bootime Fat Tire Electric Bike for Adults 1500W,28mph,75miles,Full Suspension,Removable Battery,Electric Dirt Bike,Fatbike 20" All Terrain,Snow Tires,Electric Mountain Bike,7-Speed,Ebike,Moped Style

3 Payment method Change
Pay over time with Affirm
Add a gift card or promotion code or voucher
Enter code

4 Offers

5 Review items and shipping Change
Arriving Sep 11, 2024 - Sep 16, 2024
Items shipped from Bootime Direct
 Bootime Fat Tire Electric Bike for Adults 1500W,28mph,75miles,Full Suspension,Removable Battery,Electric Dirt Bike,Fatbike 20" All Terrain,Snow Tires,Electric Mountain Bike,7-Speed,Ebike,Moped Style \$1,199.99 Qty: 1 x/ Sold by: Bootime Direct Large, bulky item Gift options not available

Choose a delivery option:
Wednesday, Sep 11 - Monday, Sep 16
FREE Delivery
 Get text updates
You consent to receive texts from us for this delivery at +1(847)925-9638. [Change](#)

Continue to application
By clicking or tapping Continue to Application, you agree to Amazon's [privacy notice](#) and [conditions of use](#).
You have selected to pay over time with Affirm, and you will need to submit an application for financing with a third party. We will share information about you, and your Amazon.com account, and this purchase transaction to assist Affirm in evaluating your finance application, and the detection and prevention of fraud.

Order Summary
Items: \$1,199.99
Shipping & handling: \$0.00
Total before tax: \$1,199.99
Estimated tax to be collected*: \$123.00
Order total: \$1,322.99

[How are shipping costs calculated?](#)

Order total: \$1,322.99
By clicking or tapping Continue to Application, you agree to Amazon's [privacy notice](#) and [conditions of use](#).

amazon Checkout (1 item)

1 Shipping address Change
 Song Lin
 451 W HURON ST UNIT 1505
 CHICAGO, IL 60654-3445
[Add delivery instructions](#)

2 Payment method Change
 Pay over time with Affirm
 Add a gift card or promotion code or voucher

3 Offers

4 Review items and shipping

Arriving Sep 11, 2024 - Sep 16, 2024
 Items shipped from SAMBATON

 **FINHOLIN 2023-Electric-Motorcycles 750W Electric-Bike Adults-Men - 20 Inch Fat-Tire Dirt Bike with 15AH Removable Battery, 6 Layer Full Suspension Mountain Commuter 7 Speed Bicycle (US Warehouse)**
\$799.00
 Qty: 1
 Sold by: SAMBATON
 Gift options not available
[Disclaimers](#)

Choose a delivery option:
 Wednesday, Sep 11 - Monday, Sep 16
 \$199.00 - Delivery

Order total: \$1,079.90
 By clicking or tapping Continue to Application, you agree to Amazon's [privacy notice](#) and [conditions of use](#).

You have selected to pay over time with Affirm, and you will need to submit an application for financing with a third party. We will share information about you, and your Amazon.com account, and this purchase transaction to assist Affirm in evaluating your finance application, and the detection and prevention of fraud.

Continue to application

By clicking or tapping Continue to Application, you agree to Amazon's [privacy notice](#) and [conditions of use](#).

You have selected to pay over time with Affirm, and you will need to submit an application for financing with a third party. We will share information about you, and your Amazon.com account, and this purchase transaction to assist Affirm in evaluating your finance application, and the detection and prevention of fraud.

Order Summary

Items:	\$799.00
Shipping & handling:	\$199.00
Total before tax:	\$998.00
Estimated tax to be collected:	\$81.90
Order total:	\$1,079.90

How are shipping costs calculated?
 Why didn't I qualify for free shipping?

amazon Checkout (1 item)

1 Shipping address Change
 Song Lin
 451 W HURON ST UNIT 1505
 CHICAGO, IL 60654-3445
[Add delivery instructions](#)

2 Payment method Change
 Pay over time with Affirm
 Add a gift card or promotion code or voucher

3 Offers

4 Review items and shipping

Arriving Sep 11, 2024 - Sep 17, 2024
 Items shipped from APFWOL US warehouse delivery)

 **APIWO Fat tire Electric Bike 48V15Ah Build-in Lithium Large Battery Long Range 20" 4.0" Fat Tire E-Bike All Terrain Mountain Snow Beach City Cruiser Electric Bike Engine Pro (Black-1)**
\$899.00
 Qty: 1
 Sold by: APFWOL US warehouse delivery)
 Gift options not available

Choose a delivery option:
 Wednesday, Sep 11 - Tuesday, Sep 17
 \$346.95 - Delivery
 The carrier will contact you by phone (+1(847)925-9638) or by email. [Change](#)

Order total: \$1,338.10
 By clicking or tapping Continue to Application, you agree to Amazon's [privacy notice](#) and [conditions of use](#).

You have selected to pay over time with Affirm, and you will need to submit an application for financing with a third party. We will share information about you, and your Amazon.com account, and this purchase transaction to assist Affirm in evaluating your finance application, and the detection and prevention of fraud.

Order Summary

Items:	\$899.00
Shipping & handling:	\$346.95
Total before tax:	\$1,245.95
Estimated tax to be collected:	\$92.15
Order total:	\$1,338.10

How are shipping costs calculated?
 Why didn't I qualify for free shipping?

*Why has sales tax been applied? [See tax and seller information.](#)
 Need help? Check our [help pages](#) or [contact us](#).

amazon Checkout (1 item)

1 Shipping address Change
 Song Lin
 451 W HURON ST UNIT 1505
 CHICAGO, IL 60654-3445
 Add delivery instructions

2 Payment method Change
 Pay over time with Affirm
 Add a gift card or promotion code or voucher
 Enter code Apply

3 Offers

4 Review items and shipping

Arriving Sep 19, 2024 - Sep 20, 2024
 Items shipped from VNUVCOE--STORE

 KETELES Electric Bike for Adults, 2000W AND Moped Style Ebike, Full Suspension Dual Motor e-bike 20" Fat Tire Dirt Bike Electric bicycle 48V 23AH Removable Battery Hydraulic Disc Brake Electric Bike
 \$1,199.00
 Qty: 1 x
 Sold by: VNUVCOE--STORE
 Gift options not available

Choose a delivery option:
 Thursday, Sep 19 - Friday, Sep 20
 FREE Delivery

Order total: \$1,321.90

By clicking or tapping Continue to Application, you agree to Amazon's [privacy notice](#) and [conditions of use](#).

You have selected to pay over time with Affirm, and you will need to submit an application for financing with a third party. We will share information about you, and your Amazon.com account, and this purchase transaction to assist Affirm in evaluating your finance application, and the detection and prevention of fraud.

Order Summary

Items	\$1,199.00
Shipping & handling	\$0.00
Total before tax	\$1,199.00
Estimated tax to be collected*	\$122.90
Order total:	\$1,321.90

How are shipping costs calculated?

*Why has sales tax been applied? [See tax and seller information.](#)
 Need help? Check our [help pages](#) or [contact us](#).

Electric Bike for Adults, 20 In | Review your order - Walmart

walmart.com/checkout/review-order?cartid=8935eb06-fada-4b01-9171-9c2a82138f00

Checkout

1. Free shipping, arrives by Wed, Sep 18 ✓

Song Lin
 451 W Huron St, Unit 1505, Chicago, IL 60654 Edit

Delivery instructions (optional) Edit
 Apartment

Items details View details
 1 item

2. Payment method +

Pay with card



Learn more about [payment methods](#) we accept.

* Required field

You're saving \$700.00 today!

Subtotal (1 item)	\$1,999.00
Savings	-\$700.00
	\$1,299.00
Shipping	Free
Estimated taxes	\$133.15
Estimated total	\$1,432.15

Have a promo code? ▼

The screenshot shows the Walmart checkout page. At the top, there are browser tabs for 'Electric Bike for Adults, 20 Inch' and 'Review your order - Walmart'. The address bar shows 'walmart.com/checkout/review-order?cartid=8935e06-fada-4b01-9171-9c2a82138f00'. The main content area is titled 'Checkout' and is divided into two sections: '1. Free shipping, arrives by Wed, Sep 18' and '2. Payment method'. The shipping section includes the customer's name 'Song Lin', address '451 W Huron St, Unit 1505, Chicago, IL 60654', and delivery instructions. The payment section shows 'Pay with card' with logos for Visa, Mastercard, American Express, Discover, and others. A summary box on the right shows: Subtotal (1 item) \$1,299.00, Shipping Free, Estimated taxes \$133.15, and Estimated total \$1,432.15. There is also a field for 'Have a promo code?'.

The screenshot shows the Temu checkout page. At the top, there are promotional banners for 'Free shipping Special for you', 'Free returns Up to 90 days*', and 'Get the Temu App'. Below these, there are offers for '5.00 Credit for delay' and '5.00 Credit for delay'. The page is divided into several sections: 'Shipping address' (Song Lin, 451 W HURON ST, UNIT 1505, CHICAGO, IL 60654, United States), 'Ships from' (Big fish Ebike (1) Local warehouse), 'Payment methods' (Card, PayPal, Cash App Pay, Afterpay), and 'Order summary'. The order summary shows: Item(s) total \$949.99, Item(s) discount -\$142.51, Subtotal \$807.48, Shipping FREE, Sales tax \$82.77, and Order total \$890.25. There is also a 'Submit order' button and a 'Plant with Temu' section.

Temu

Free shipping Special for you

Delivery guarantee Refund for any issues

Get the Temu App

All data is encrypted

Home > Checkout

Free shipping on all items of this order

Shipping address [Change address >](#)

Song Lin +1 (847)925-9638
451 W HURON ST, UNIT 1505
CHICAGO, IL 60654, United States

Ships from **Big fish Ebike (1)** Local warehouse

Electric Mountain Bike - 20MPH, 16AH Removable Battery, Coarse Tire & Suspension, All-Terrain E Bike f...
Black
Qty: 1

Anniversary sale | -10% limited time

Almost sold out

\$848.29 ~~\$949.99~~

Standard shipping: FREE, delivery: 2-7 business days >

Payment methods

Card VISA Mastercard American Express Discover

PayPal

Cash App Pay @

Afterpay @ 4 interest-free payments of \$233.81

Order summary

Enter coupon code

Apply coupon code >

Item(s) total:	\$949.99
Item(s) discount:	-\$101.70
Subtotal:	\$848.29
Shipping:	FREE
Sales tax:	\$86.95
Order total:	\$935.24

Plant with Temu

We invite you to plant a tree for \$0.35 @

1 almost sold out

Temu's Tree Planting Program

Temu and its users have donated funds to Trees for the Future to plant trees across sub-Saharan Africa @

Temu protects your card information

- ✓ Temu follows the Payment Card Industry Data Security Standard (PCI DSS) when handling card data
- ✓ Card information is secure and uncompromised
- ✓ All data is encrypted
- ✓ Temu never sells your card information

Subscribe

Temu

Free shipping Special for you

Delivery guarantee Refund for any issues

Get the Temu App

All data is encrypted

Home > Checkout

Free shipping on all items of this order

Shipping address [Change address >](#)

Song Lin +1 (847)925-9638
451 W HURON ST, UNIT 1505
CHICAGO, IL 60654, United States

Ships from **COONY eBike (1)** Local warehouse

Electric Bike For Adults, 750W 750W Full Drive 48V 16Ah Ebike 20MPH Electric Bicycles 7-Speed With Full...
Black
Qty: 1

Big sale | -15% limited time

Almost sold out

\$805.88 ~~\$949.99~~

Standard shipping: FREE, delivery: 2-7 business days >

Payment methods

Card VISA Mastercard American Express Discover

PayPal

Cash App Pay @

Afterpay @ 4 interest-free payments of \$222.12

Order summary

Enter coupon code

Apply coupon code >

Item(s) total:	\$949.99
Item(s) discount:	-\$144.11
Subtotal:	\$805.88
Shipping:	FREE
Sales tax:	\$82.60
Order total:	\$888.48

Plant with Temu

We invite you to plant a tree for \$0.35 @

1 almost sold out

Temu's Tree Planting Program

Temu and its users have donated funds to Trees for the Future to plant trees across sub-Saharan Africa @

Temu protects your card information

- ✓ Temu follows the Payment Card Industry Data Security Standard (PCI DSS) when handling card data
- ✓ Card information is secure and uncompromised
- ✓ All data is encrypted
- ✓ Temu never sells your card information

Free shipping Special for you | Price adjustment Within 30 days | Get the Temu App

Home > Checkout

Free shipping on all items of this order

Shipping address: Song Lin +1 (847)925-9638, 451 W HURON ST, UNIT 1505, CHICAGO, IL 60654, United States

Ships from Aiken Ebike (1) Local warehouse: 750W High-Speed Electric Bike for Adults - 20MPH, 48V 16AH Battery, Up to 75 Miles Range, 7-Speed Ge... Black, Qty: 1, \$795.48

Payment methods: Card, PayPal, Cash App Pay, Afterpay

Order summary: Item(s) total: \$1,599.99, Item(s) discount: -\$804.51, Subtotal: \$795.48, Shipping: FREE, Sales tax: \$81.54, Order total: \$877.02

Submit order

Free shipping Special for you | Price adjustment Within 30 days | Get the Temu App

Home > Checkout

Free shipping on all items of this order

Shipping address: Song Lin +1 (847)925-9638, 451 W HURON ST, UNIT 1505, CHICAGO, IL 60654, United States

Ships from Scooter Electric (1) Local warehouse: Electric off-road SUV, adult, Max. 28 miles, 7-speed twin suspension and disc brakes, 20 by 4.0 inch fat tir... Electric Bike [BLACK], Qty: 1, \$890.48

Payment methods: Card, PayPal, Cash App Pay, Afterpay

Order summary: Item(s) total: \$949.99, Item(s) discount: -\$59.51, Subtotal: \$890.48, Shipping: FREE, Sales tax: \$91.27, Order total: \$981.75

Submit order

Free shipping Special for you | Delivery guarantee Refund for any issues | Get the Temu App

Home > Checkout

Free shipping on all items of this order

Shipping address [Change address >](#)

Song Lin +1 (847)925-9638
451 W HURON ST, UNIT 1505
CHICAGO, IL 60654, United States

Ships from **AROMEI (1)** Local warehouse

750W Powerful Electric Dirt Bike 20MPH 48V 16Ah Removable Battery Electric Bike 20"x4.0" Fat Tire Elect...
Black Qty: 1

Almost sold out \$848.30

Standard shipping: FREE, delivery: 3-7 business days >

Payment methods

- Card VISA Mastercard American Express Discover
- PayPal
- Cash App Pay @
- Afterpay @ 4 interest-free payments of \$233.81

Order summary

Enter coupon code

Apply coupon code >

Item(s) total:	\$848.30
Shipping:	FREE
Sales tax:	\$86.95
Order total:	\$935.25

Plant with Temu

We invite you to plant a tree for \$0.35 @

1 almost sold out

Temu's Tree Planting Program

Temu and its users have donated funds to Trees for the Future to plant trees across sub-Saharan Africa @

Temu protects your card information

- ✓ Temu follows the Payment Card Industry Data Security Standard (PCI DSS) when handling card data
- ✓ Card information is secure and uncompromised
- ✓ All data is encrypted
- ✓ Temu never sells your card information

Free shipping Special for you | Delivery guarantee Refund for any issues | Get the Temu App

Home > Checkout

Free shipping on all items of this order

Shipping address [Change address >](#)

Song Lin +1 (847)925-9638
451 W HURON ST, UNIT 1505
CHICAGO, IL 60654, United States

Ships from **LEEHE Ebike (1)** Local warehouse

Electric Bike For Adults, 20"x4.0" Fat Tire 750W Brushless Motor 48V 20A Removable Battery Bicycles WIL...
Black Qty: 1

Anniversary sale | -32% limited time

\$810.98 ~~\$1,199.99~~

Standard shipping: FREE, delivery: 2-7 business days >

Payment methods

- Card VISA Mastercard American Express Discover
- PayPal
- Cash App Pay @
- Afterpay @ 4 interest-free payments of \$223.52

Order summary

Enter coupon code

Apply coupon code >

Item(s) total:	\$1,199.99
Item(s) discount:	-\$389.01
Subtotal:	\$810.98
Shipping:	FREE
Sales tax:	\$83.13
Order total:	\$894.11

Plant with Temu

We invite you to plant a tree for \$0.35 @

1 almost sold out

Temu's Tree Planting Program

Temu and its users have donated funds to Trees for the Future to plant trees across sub-Saharan Africa @

Temu protects your card information

- ✓ Temu follows the Payment Card Industry Data Security Standard (PCI DSS) when handling card data
- ✓ Card information is secure and uncompromised
- ✓ All data is encrypted
- ✓ Temu never sells your card information

正在等待 www.temu.com 的响应...

Free shipping Special for you | Delivery guarantee Refund for any issues | Get the Temu App

Home > Checkout

Free shipping on all items of this order

Shipping address: Song Lin +1 (847)925-9638, 451 W HURON ST, UNIT 1505, CHICAGO, IL 60654, United States

Ships from: Huao Time (1) Local warehouse

16AH Removable Battery, Riding times 750W Moped Style Electric Bike, 20 Inch Fat Tire & Rear Suspensi...
Black
Anniversary sale | Limited time
Almost sold out
\$807.48
Standard shipping: FREE, delivery: 3-7 business days

Payment methods: Card, PayPal, Cash App Pay, Afterpay

Order summary: Item(s) total: \$807.48, Shipping: FREE, Sales tax: \$82.77, Order total: \$890.25

Plant with Temu: We invite you to plant a tree for \$0.35 @

Submit order (1 almost sold out)

Temu's Tree Planting Program: Temu and its users have donated funds to Trees for the Future to plant trees across sub-Saharan Africa @

Temu protects your card information: Temu follows the Payment Card Industry Data Security Standard (PCI DSS) when handling card data. Card information is secure and uncompromised. All data is encrypted. Temu never sells your card information.

Free shipping Special for you | Delivery guarantee Refund for any issues | Get the Temu App

Home > Checkout

Free shipping on all items of this order

Shipping address: Song Lin +1 (847)925-9638, 451 W HURON ST, UNIT 1505, CHICAGO, IL 60654, United States

Ships from: Aizepa ebike (1) Local warehouse

750W Moped Style Electric Bike, 20 Inch Fat Tire & 6-Layer Full Suspension Ebike, Up To 20 MPH & 75 ML...
Black
Top deals | +13% limited time
Almost sold out
\$826.35 \$949.99
Standard shipping: FREE, delivery: 3-7 business days

Payment methods: Card, PayPal, Cash App Pay, Afterpay

Order summary: Item(s) total: \$949.99, Item(s) discount: -\$123.64, Subtotal: \$826.35, Shipping: FREE, Sales tax: \$84.70, Order total: \$911.05

Plant with Temu: We invite you to plant a tree for \$0.35 @

Submit order (1 almost sold out)

Temu's Tree Planting Program: Temu and its users have donated funds to Trees for the Future to plant trees across sub-Saharan Africa @

Temu protects your card information: Temu follows the Payment Card Industry Data Security Standard (PCI DSS) when handling card data. Card information is secure and uncompromised. All data is encrypted. Temu never sells your card information.

正在等待 www.temu.com 的响应...

Free shipping Special for you | Delivery guarantee Refund for any issues | Get the Temu App

Home > Checkout

Free shipping on all items of this order

Shipping address: Song Lin +1 (847)925-9638, 451 W HURON ST, UNIT 1505, CHICAGO, IL 60654, United States

Ships from Besintu D (1) Local warehouse

Adult Electric Bike, 750W Brushless Motor, 20MPH 40 Miles, Removable Battery 48V 15.6AH, 7 Speed, 20" Black / wheel 20" 48V 15.6AH

Special sale | -18% last day

Qty: 1

Standard shipping: FREE, delivery: 2-7 business days

Payment methods: Card, PayPal, Cash App Pay, Afterpay

Order summary:

Item(s) total:	\$829.00
Item(s) discount:	-\$156.57
Subtotal:	\$672.43
Shipping:	FREE
Sales tax:	\$15.13
Order total:	\$687.56

Plant with Temu: We invite you to plant a tree for \$0.35 @

Submit order Special sale 12/5/27

Temu's Tree Planting Program: Temu and its users have donated funds to Trees for the Future to plant trees across sub-Saharan Africa @

Temu protects your card information: Temu follows the Payment Card Industry Data Security Standard (PCI DSS) when handling card data. Card information is secure and uncompromised. All data is encrypted. Temu never sells your card information.

Free shipping Special for you | Delivery guarantee Refund for any issues | Get the Temu App

Home > Checkout

Free shipping on all items of this order

Shipping address: Song Lin +1 (847)925-9638, 451 W HURON ST, UNIT 1505, CHICAGO, IL 60654, United States

Ships from ketelesebike (1) Local warehouse

KETELESE Brand electric bike KETELESE Electric Bike For Adults, 20" Fat Tire Powerful 750W Brushless Motor, ...

Black

Special sale | Limited time

Qty: 1

Standard shipping: FREE, delivery: 3-7 business days

Payment methods: Card, PayPal, Cash App Pay, Afterpay

Order summary:

Item(s) total:	\$818.18
Shipping:	FREE
Sales tax:	\$83.86
Order total:	\$902.04

Plant with Temu: We invite you to plant a tree for \$0.35 @

Submit order 1 almost sold out

Temu's Tree Planting Program: Temu and its users have donated funds to Trees for the Future to plant trees across sub-Saharan Africa @

Temu protects your card information: Temu follows the Payment Card Industry Data Security Standard (PCI DSS) when handling card data. Card information is secure and uncompromised. All data is encrypted. Temu never sells your card information.

Temu

Free shipping Special for you

Delivery guarantee Refund for any issues

Get the Temu App

All data is encrypted

Home > Checkout

Free shipping on all items of this order

Shipping address [Change address >](#)

Song Lin +1 (847)925-9638
451 W HURON ST, UNIT 1505
CHICAGO, IL 60654, United States

Ships from **KETELESBIKEUS (1)** Local warehouse

PRODUCT DETAILS **KETELES** Authorized provider: KETELES Electric Bike For Adults, 20" Fat Tire Powerful 750W Brushless Moto...
army green Qty: 1

Almost sold out \$913.49 ~~\$1,799.00~~ (-49%)

Standard shipping: FREE, delivery: 2-7 business days >

Payment methods

- Card
- PayPal
- Cash App Pay @
- Afterpay @ 4 interest-free payments of \$233.51

Order summary

Enter coupon code

Apply coupon code >

Item(s) total:	\$1,799.00
Item(s) discount:	-\$885.51
Subtotal:	\$913.49
Shipping:	FREE
Sales tax:	\$20.55
Order total:	\$934.04

Plant with Temu

We invite you to plant a tree for \$0.35 @

1 almost sold out

Temu's Tree Planting Program
Temu and its users have donated funds to Trees for the Future to plant trees across sub-Saharan Africa @

Temu protects your card information

- ✓ Temu follows the Payment Card Industry Data Security Standard (PCI DSS) when handling card data
- ✓ Card information is secure and uncompromised
- ✓ All data is encrypted
- ✓ Temu never sells your card information

Temu

Free shipping Special for you

Delivery guarantee Refund for any issues

Get the Temu App

All data is encrypted

Home > Checkout

Free shipping on all items of this order

Shipping address [Change address >](#)

Song Lin +1 (847)925-9638
451 W HURON ST, UNIT 1505
CHICAGO, IL 60654, United States

Ships from **AMYET EBIKE (1)** Local warehouse

Authorized provider: AMYET S8 Electric Mountain Bike - 750W AWD Motor, 48V 25Ah Battery, 20...
AMYET S8 BLACK / Adult Qty: 1

Big sale | +11% limited time
Only 8 left \$934.53 ~~\$1,056.49~~

Standard shipping: FREE, delivery: 2-7 business days >

Payment methods

- Card
- PayPal
- Cash App Pay @
- Afterpay @ 4 interest-free payments of \$257.58

Order summary

Enter coupon code

Apply coupon code >

Item(s) total:	\$1,056.49
Item(s) discount:	-\$121.96
Subtotal:	\$934.53
Shipping:	FREE
Sales tax:	\$95.79
Order total:	\$1,030.32

Plant with Temu

We invite you to plant a tree for \$0.35 @

1 almost sold out

Temu's Tree Planting Program
Temu and its users have donated funds to Trees for the Future to plant trees across sub-Saharan Africa @

Temu protects your card information

- ✓ Temu follows the Payment Card Industry Data Security Standard (PCI DSS) when handling card data
- ✓ Card information is secure and uncompromised
- ✓ All data is encrypted
- ✓ Temu never sells your card information

Temu Checkout | eBay

pay.ebay.com/rxio?action=view&sessionId=226266567012

🏠 导航 🌐 语言 🌐 币种 🌐 货币 🌐 国家

VISA x-8243

Add new card

Google Pay Google Pay

Pay Later No interest if paid in full in 6 months. Apply now. [See terms](#)

Ship to
Song Lin
451 W Huron St. UNIT 1505
Chicago, IL 60654-3445
United States
(617) 415-6717
[Change](#)

Review order

ceilingLED - [Add note for seller](#)
94.2% positive feedback - [Top Rated Seller](#)

 20" Electric Bicycle 750W Fat Tire Mountain Bike MTB All-terrain off-road Bike US
\$999.99

Quantity: 1

Delivery
Free FedEx Ground Economy
Est. delivery: Sep 12 - Sep 17

Gift cards and coupons

Item (1) \$999.99
Shipping Free
Tax* \$102.50

Order total \$1,102.49

By placing your order, you agree to eBay's [User Agreement](#) and [Privacy Policy](#).
*We're required by law to collect sales tax and applicable fees for certain tax authorities. [Learn more](#)

Confirm and pay

Purchase protected by eBay Money Back Guarantee

Temu Checkout | eBay

pay.ebay.com/rxio?action=view&sessionId=2262667534012

🏠 导航 🌐 语言 🌐 币种 🌐 货币 🌐 国家

Venmo

VISA x-0115

VISA x-8243

Add new card

Google Pay Google Pay

Pay Later No interest if paid in full in 6 months. Apply now. [See terms](#)

Ship to
Nicholas S. Lee
1475 E Woodfield Rd. Ste 600
Schaumburg, IL 60173-5485
United States
(847) 969-9123-8
[Change](#)

Review order

ceilingLED - [Add note for seller](#)
94.2% positive feedback - [Top Rated Seller](#)

 16" Electric Bicycle 250W Motorcycle City Flat Road E-Bike for Youngster Girl US
\$699.95

Quantity: 1

Delivery
Free FedEx Ground Economy
Est. delivery: Sep 24 - Oct 12

Item (1) \$699.95
Shipping Free
Tax* \$70.00

Order total \$769.95

By placing your order, you agree to eBay's [User Agreement](#) and [Privacy Policy](#).
*We're required by law to collect sales tax and applicable fees for certain tax authorities. [Learn more](#)

Confirm and pay

Purchase protected by eBay Money Back Guarantee

Temu Checkout | eBay

pay.ebay.com/rvo?action=view&sessionId=2268267673012

Add new card

- VISA
- Add new card
- No interest if paid in full in 6 months. Apply now: [See terms](#)

Ship to

Nicholas S. Lee
1475 E Woodfield Rd, Ste 600
Schaumburg, IL 60173-5485
United States
(847) 969-9123-8
[Change](#)

Review order

KETELES - [Add note for seller](#)
93.1% positive feedback · [Top Rated Seller](#)

 KETELES 20" 48V 23Ah Electric Bicycle for adult 30tPH 2000W Dual Motor E-Bike US
\$1,199.00

Quantity: 1

Returns accepted

Delivery
Free Economy Shipping
Est. delivery: Sep 12 - Sep 17

Gift cards and coupons

Enter code:

Item (1) \$1,199.00
Shipping Free
Tax* \$119.90
Order total \$1,318.90

By placing your order, you agree to eBay's [User Agreement](#) and [Privacy Notice](#).
*We're required by law to collect sales tax and applicable fees for certain tax authorities.
[Learn more](#)

 Purchase protected by **eBay Money Back Guarantee**

Temu Checkout | eBay

pay.ebay.com/rvo?action=view&sessionId=2268267880012

VISA x-8243

Add new card

Google Play

No interest if paid in full in 6 months. Apply now: [See terms](#)

Ship to

Nicholas S. Lee
1475 E Woodfield Rd, Ste 600
Schaumburg, IL 60173-5485
United States
(847) 969-9123-8
[Change](#)

Review order

KAUJELAISI - [Add note for seller](#)
99.7% positive feedback

 KETELES 20" 48V 1180WH 23Ah Electric Bicycle for adult 2000W Dual Motor E-Bike
\$1,099.00

Quantity: 1

Returns accepted

Delivery
Free Economy Shipping
Est. delivery: Sep 13 - Sep 18

Gift cards and coupons

Item (1) \$1,099.00
Shipping Free
Tax* \$109.90
Order total \$1,208.90

By placing your order, you agree to eBay's [User Agreement](#) and [Privacy Notice](#).
*We're required by law to collect sales tax and applicable fees for certain tax authorities.
[Learn more](#)

 Purchase protected by **eBay Money Back Guarantee**

Temu Checkout | eBay

pay.ebay.com/rxto?action=view&sessionId=2268268001012

导航 商店 天猫 京东 百度

Add new card

Google Pay

No interest if paid in full in 6 months. Apply now. [See terms](#)

Ship to
Nicholas S. Lee
1475 E Woodfield Rd. Ste 600
Schaumburg, IL 60173-5485
United States
(847) 969-9123-8
[Change](#)

Review order

[Add note for seller](#)
130% positive feedback

k880 Electric Bike 2000W 23AH AWD Dual Motor Dual Suspension
20" Fat Tyre E-bike
\$1,199.00

Quantity: 1

Returns accepted

Delivery
Free FedEx Ground or FedEx Home Delivery
Est. delivery: Sep 12 - Sep 17

Gift cards and coupons

Enter code:

Item (1) \$1,199.00
Shipping Free
Tax* \$119.90











Order total \$1,318.90











By placing your order, you agree to eBay's [User Agreement](#) and [Privacy Policy](#).
*Taxes required by law to collect sales tax and applicable fees for certain tax authorities. [Learn more](#)

Purchase protected by **eBay Money Back Guarantee**

?

EXHIBIT C

Defendant #	Seller Name	Claimed E-Bike	Infringing E-Bike Offered For Sale by Defendants
#1	Riding'times DIRECT		
#2	Kaijian Mo		
#3	Riding'times Shop		
#4	Bootime Direct		
#5	SAMBATON		

#6	APIWO(US warehouse delivery)		
#7	VNUVCOE Store		
#8	KISTP		
#9	GYROOR		
#10	Big fish Ebike		

#11	Big fish Ebike	 A black electric bicycle with a large front headlight, a black seat, and a battery pack mounted on the frame.	 A black electric bicycle, similar to the one in the previous image, shown from a slightly different angle.
#12	COONY eBike	 A black electric bicycle with a large front headlight, a black seat, and a battery pack mounted on the frame.	 A black electric bicycle shown on a stylized road graphic with a white dashed line.
#13	Aiken Ebike	 A black electric bicycle with a large front headlight, a black seat, and a battery pack mounted on the frame.	 A black electric bicycle shown from a slightly different angle.
#14	Scooter Electric	 A black electric bicycle with a large front headlight, a black seat, and a battery pack mounted on the frame.	 A black electric bicycle shown on a stylized road graphic with a white dashed line.
#15	Aromei	 A black electric bicycle with a large front headlight, a black seat, and a battery pack mounted on the frame.	 A black electric bicycle with a splatter effect around the base of the frame.
#16	LEEHE Ebike	 A black electric bicycle with a large front headlight, a black seat, and a battery pack mounted on the frame.	 A black electric bicycle with a colorful splatter effect around the base of the frame and a red '750W' label.

#17	Huao Time		
#18	Aizepa ebike		
#19	movcan shop		
#20	ketelesebike		
#21	KETELESEBIKEUS		
#22	AMYET EBIKE		

#23	ceilingLED		
#24	ceilingLED		
#25	KETELES		
#26	KAJIJELAISI		
#27	keteles-EbikeStore		