

**UNITED STATES DISTRICT COURT
NORTHERN DISTRICT OF ILLINOIS
EASTERN DIVISION**

Shenzhen Xiang Wang Technology Co., Ltd.,

Plaintiff,

v.

Vikingstrength, LLC,

Defendants.

CASE NO. 24-cv-12486

Jury Demand

COMPLAINT

This is an action brought under the Declaratory Judgment Act by Plaintiff Shenzhen Xiang Wang Technology Co., Ltd., (“Plaintiff” or “XW Tech”), against Defendant Vikingstrength LLC (“Defendant”). Upon actual knowledge with respect to itself and its acts, and upon information and belief as to all other matters, Plaintiff alleges as follows:

NATURE OF THE ACTION

1. This court has original jurisdiction over the subject matter of this action pursuant to the Patent Act, 35 U.S.C. §§ 101, 102, 103 et seq., pursuant to 28 U.S.C. §§ 1331, 1332(a) and (c), 1338(a), and pursuant to the Declaratory Judgment Act, 28 U.S.C. §§ 2201 and 2202.

2. This is an action under the Declaratory Judgment Act, 28 U.S.C. §§ 2201 and 2202, seeking a declaratory judgment that Plaintiff has not infringed any alleged Patent of Defendant (including any of Defendant’s predecessors and/or successors in interest), directly, contributorily, or vicariously.

3. This is an action under the Declaratory Judgment Act, 28 U.S.C. §§ 2201 and 2202, seeking a declaratory judgment that Defendant's Patent U.S. Patent No. D1,052,668 is invalid under at least 35 U.S.C. §§ 102 and 103.

4. This action arises from Defendant's filing of Patent infringement complaint to Amazon, causing Amazon to de-list Plaintiff's product from the market, which could lead to the total shut down of Plaintiff's business.

JURISDICTION AND VENUE

5. This Court has subject matter jurisdiction under 28 U.S.C. §§ 2201, 2202, 1331, 1338(a), because this action arises under the laws of the United States, in particular the Patent Act of the United States, 35 U.S.C. § 100 et seq.

6. An actual case or controversy exists between the parties to this action. Defendant filed the patent infringement complaint to Amazon which resulted in the removal of Plaintiff's Amazon product listings. Product delisting from Amazon has stopped Plaintiff's product sales on Amazon and caused significant financial loss in the United States, including Chicago, Illinois. Defendant's actions thereby give rise to an actual controversy under 28 U.S.C. §§ 2201 et. seq.

7. Venue is proper in this Court pursuant to 28 U.S.C. § 1391, and this Court may properly exercise personal jurisdiction over the Defendant since the Defendant has directly availed himself of the United States, including Illinois, by filing a patent infringement complaint against Plaintiff with Amazon, causing Plaintiff's ASINs to be taken down by Amazon, which has affected sales and activities in the state of Illinois.

8. Defendant also avails itself by operating online stores, such as Amazon.com. Defendant uses these online platforms to sell Wrist Roller that practice the Patent. Defendant sells its products in the United States, including in Illinois.

https://www.amazon.com/sp?ie=UTF8&seller=A3M92PS06QFJ33&asin=B08714ZTFQ&ref=dp_merchant_link&isAmazonFulfilled=1

THE PARTIES

THE PLAINTIFF

9. Plaintiff, Shenzhen Xiang Wang Technology Co., Ltd., operates an Amazon store under the name Xiangwang US Ltd., with Seller ID **AT6IV2T75C5HE**. Plaintiff is a company based in the People's Republic of China, with its address at D-1005, No. 2 Xuwu Road, Bitou Community, Songgang Street, Bao'an District, Shenzhen City, Guangdong Province, 518000, China.

THE DEFENDANT

10. Upon information and belief, Defendant is a Norwegian company located at Blåtoppveien 41, Hagan, 1481, Norway. Defendant operates an Amazon store under the name Vikingstrength, with Seller ID A3M92PS06QFJ33.

FACTUAL BACKGROUND

11. Plaintiff sells Wrist Roller in its Amazon store.

12. On November 29, 2024, Plaintiff received a cease and desist letter from the Defendant, stating that four of Plaintiff's ASINs infringed Defendant's design patent D1,052,668 ("668 Patent"). **Exhibit A.**

13. Then On December 5, 2024, Plaintiff received a notice from Amazon stating that Defendant had filed a complaint against Plaintiff for design patent infringement of the '688 Patent, resulting in the de-listing of Plaintiff's ASINs. The affected ASINs are: B0D7397J6M, B0D73DRFS7, B0D739D2TM, and B0D736RX9Z. **Exhibit B.**

14. In the complaint, Defendant alleged that: " Protected Design Elements The Patent

protects the ornamental design of a wrist roller device, specifically: 1. Handle Design: A proprietary cylindrical structure with ergonomic dimensions integral to the patented design. 2. **Attachment Mechanism:** Unique rope or cable integration points as part of the handle design. 3. Overall Design Unity: A blend of geometric and ergonomic elements

15. By using the term “Attachment Mechanism,” Defendant is intentionally attempting to blur the distinction between design patents and utility patents, seeking to use the design patent to improperly protect the functional aspects of Defendant’s product.

16. Defendant’s design patent D1,052,668 filing date is May3, 2021. **Exhibit C.** The Date of Patent is November 26, 2024. The drawings of the ’668 Patent is shown as below:

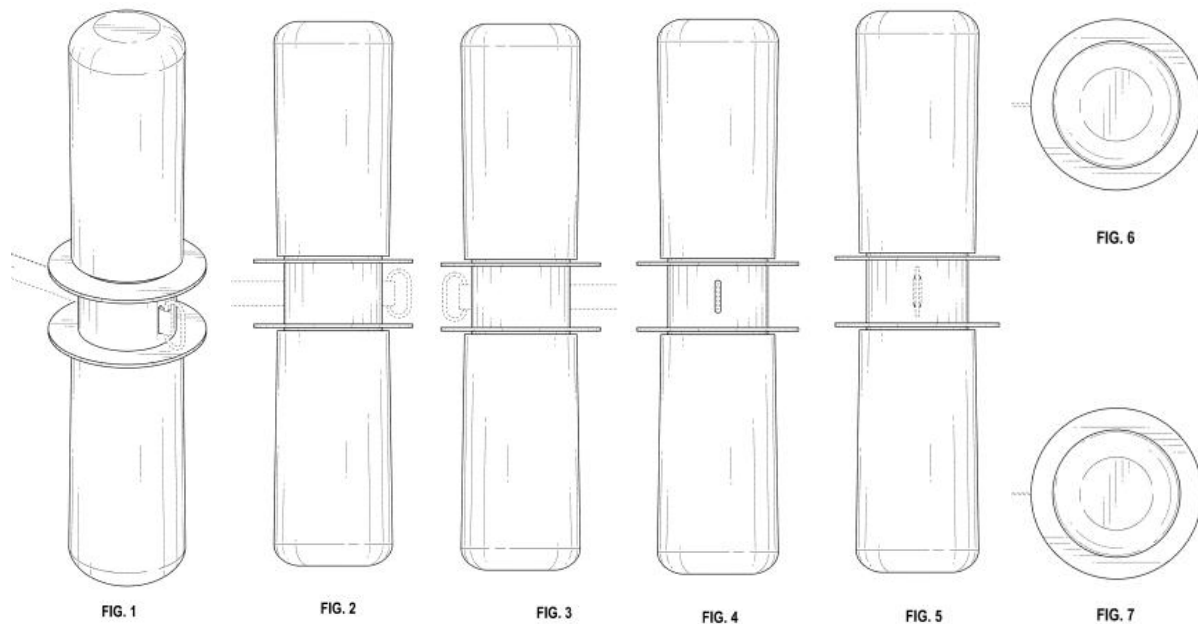

17. However, the ‘688 Patent is invalid, and even if it were valid, Plaintiff’s product does not infringe the ‘688 Patent.

COUNT I
(Declaration Judgment of Invalidity of U.S. Patent, No. D1,052,668)

18. Plaintiff incorporates by reference the allegations set forth above in this Complaint as if fully set forth herein.

19. This claim arises under the patent laws of the United States, Title 35 United States Code, and the Federal Declaratory Judgment Act, 28 U.S.C. § 2201, et seq.

20. There exists an actual and justiciable controversy between Plaintiff and Defendant with respect to the alleged validity of the '668 Patent due to the assertion of the '668 Patent against the Plaintiff's product.

21. The claimed design of '668 Patent was invalid under 35 U.S.C §§ 103 because the claimed invention would have been obvious to a person with ordinary skill in the art before the filing date

22. Two potential invalidity combinations can be seen below:

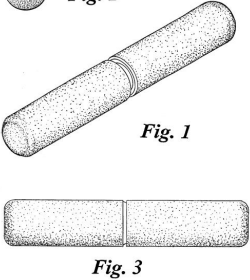
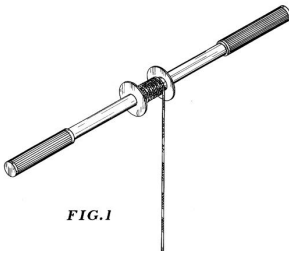
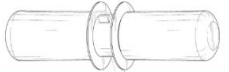
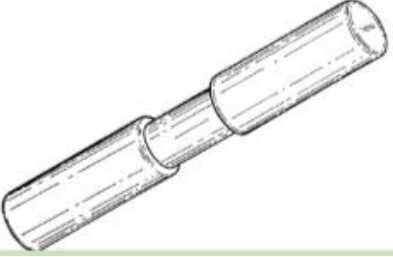
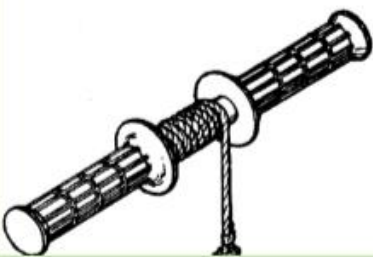
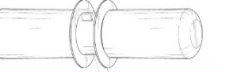
No. 1	USD451564S1 (Exhibit D)	USD264237S1(Exhibit E)	Defendant's Patent
			
No. 2	USD428946S1(Exhibit F)	USD268436S1(Exhibit G)	Defendant's Patent
			

23. Based on the foregoing combinations, the '668 Patent is rendered obvious under 35 U.S.C. § 103. Therefore, the '668 Patent is invalid and should not be enforceable.

24. In the view of the foregoing, Plaintiff is entitled to a judgment declaring that the '668 Patent is invalid.

COUNT II

(Declaration Judgment of Non-infringement of U.S. Patent, No. D1,052,668)

25. Plaintiff incorporates by reference the allegations set forth above in this Complaint as if fully set forth herein.

26. As described previously, Defendant alleges that Plaintiff's product infringes the '668 Patent.

27. The circumstances show that there is an actual, present, substantial, and justiciable controversy between Plaintiff and Defendant, which have adverse legal interests, of sufficient immediacy and reality to warrant the issuance of a declaratory judgment.

28. The '688 Patent, due to strong functional considerations, requires a clear distinction between functional and ornamental features. The so-called functional design elements include the two side handles, the two central flanges, and the cylindrical portion in the middle for winding the rope. These three design features/elements are standard functional requirements for this type of product and represent a basic or generic design concept that is inherently functional.

29. As such, these functional elements must be excluded. After excluding these elements, the scope of the patent claim is reduced to only the narrow ornamental features, such as the outward-sloping contour of the two handles, the rounded conical design at the ends of the handles, and the very small rope outlet in the middle.

30. Even assuming that Plaintiff's accused design and Defendant's patent are not sufficiently distinct or plainly dissimilar, a comparison incorporating prior art reveals significant differences. When visually comparing the claimed design, the accused design, and any relevant prior art identified by the accused infringer, differences that may have initially gone unnoticed

become apparent. These differences, highlighted through the lens of prior art, are sufficient to demonstrate that Plaintiff's accused product does not infringe Defendant's patent.

31. The prior arts can be seen as follows:

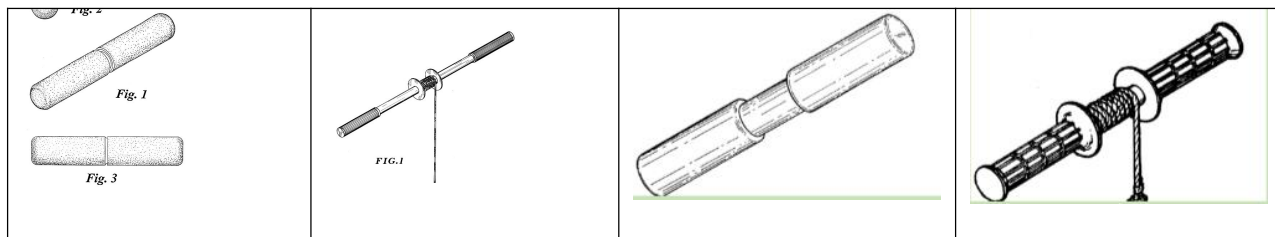

32. The prior art has already established the basic appearance profile for this type of product. The prior art has laid the foundation for this type of product, with both the '668 patent and Plaintiff's building upon it through redesign and further improvement

	USD1052668	Plaintiff's product
Difference No. 1		
Difference No. 2		
Difference No. 3		

33. The Asserted Patent features a flat-ended design, whereas Plaintiff's product has a domed design with a regular spherical shape.

34. The Asserted Patent's opening is located in the center and occupies only a small portion between the two flanges, while Defendant's opening spans the entire area between the two flanges.

35. The Asserted Patent's handle slopes inward with a concave shape, whereas Plaintiff's product features straight handles

36. Based on these noticeable differences mentioned above, an ordinary observer would clearly be able to distinguish between Plaintiff's product and the '668 patent. Therefore, Plaintiff's product does not infringe the '668 patent

37. Plaintiff seeks a declaratory judgment that Plaintiff is not infringing, has not infringed and is not liable for infringing the '668 Patent.

COUNT III
(Tortious Interference with Contractual Relations)

38. Plaintiff incorporates by reference the allegations set forth above in this Complaint as if fully set forth herein.

39. The elements of a claim for tortious interference with contract are: (1) the existence of a valid contract between the plaintiff and a third party; (2) the defendant's knowledge of the contract; (3) the defendant's intentional procurement of the third-party's breach of the contract without justification; (4) the defendant's wrongful conduct caused the third party to breach of the contract; and (5) damages resulting therefrom.

40. Plaintiff has a valid and existing contract with Amazon in order to sell their products through Amazon.com

41. Plaintiff is informed and believes, and on that basis alleges, that Defendant knew of Plaintiff's contractual relationships with the Amazon.

42. Plaintiff is informed and believes, and on that basis alleges, that Defendant intentionally interfered with those contractual relationships and furthermore knowingly and intentionally, by ways of asserting materially false allegations of patent infringement against Plaintiff in order to have Plaintiff's listing removed and eliminate Plaintiff's lawful competition.

43. As a result of Defendant's improper acts, Plaintiff's listings were removed from Amazon.

44. Plaintiff has suffered direct, proximate and foreseeable damages and continues to suffer direct, proximate and foreseeable damages.

45. Defendant's efforts to have Plaintiff's products delisted through improper means was and is unlawful, fraudulent.

46. By reason of Defendant's acts, Plaintiff is entitled to equitable remedies and damages in an amount to be proven at trial.

COUNT IV
(Tortious Interference with Prospective Economic Advantage)

47. Plaintiff incorporates by reference the allegations set forth above in this Complaint as if fully set forth herein.

48. The elements of a claim for tortious interference with prospective economic advantage are: (1) the plaintiff had a reasonable expectation of entering into or continuing a valid business relationship with a third party; (2) the defendant knew of that expectation; (3) the defendants intentionally and without justification interfered with that expectation; (4) the defendant's interference prevented the plaintiff's legitimate expectancy from ripening into a valid business relationship and (5) the plaintiff suffered damages as a result of the interference.

49. Plaintiff's ongoing business relationship with Amazon included the selling of Wrist Roller now delisted as a result of Defendant's malicious and spurious infringement complaint.

50. Plaintiff's ongoing business relationship with Amazon includes the current sale of products which Defendant claims are infringing.

51. Defendant had and continues to have full knowledge of the ongoing relationships and prospective future business arrangements between Plaintiff and Amazon regarding Plaintiff's sale of Wrist Roller products.

52. Defendant intentionally and knowingly made fraudulent assertions of patent infringement, which ultimately caused Amazon to remove Plaintiff's listing, thus denying the future and ongoing business relationship between Plaintiff with Amazon.

53. Defendant knew that the removal of Plaintiff's product listings would harm Plaintiff's business and would benefit Defendant due to it having less competition. Defendant intended to harm Plaintiff by fraudulently convincing Amazon to remove Plaintiff's product listing.

54. Defendant has no privilege or justification in interfering with Plaintiff's relationship with Amazon.

55. As a result of Defendant's interference with Plaintiff's ongoing and future relationship with Amazon, Plaintiff has incurred damages and will continue to incur damages

56. The damages to Plaintiff should its product be delisted as a result of Defendant's malicious complaint against Plaintiff will result in the incurring removal fees, transport fees, and fees associated with transportation of the delisted products

57. The delisting of Plaintiff's ASIN would result in an immediate and ongoing detrimental impact on Plaintiff's ability to conduct business, remain profitable, and damage Plaintiff's product's rankings and reviews, loss of Plaintiff's goodwill and reputation on the Amazon marketplace. The damage to Plaintiff should its product continue to be delisted as a result of Defendant's frivolous action against Plaintiff is incalculable and irreparable.

58. By reason of the foregoing, Plaintiff has suffered direct, proximate and foreseeable damages in an amount to be proven at trial.

PRAYER FOR RELIEF

WHEREFORE, Plaintiff prays for judgment against Defendant as follows:

1. For judgment in favor of Plaintiff against Defendant on all claims.
2. Declaring that Defendant's D1,052,668 Patent registration is invalid.
3. Declaring that Plaintiff's Wrist Roller products does not infringe Defendant's D1,052,668 Patent.
4. Judgment that this case is exceptional and that the Defendant be ordered to pay all Plaintiff's costs and attorneys' fees associated with this action pursuant to 35 U.S.C. § 285.
5. Order by this Court that Defendant must immediately revoke any complaints of infringement of the D1,052,668 Patent made to Amazon with respect to Plaintiff's Wrist Roller products.
6. Enjoining Defendant temporarily, preliminarily, and permanently from making any future complaint regarding the D1,052,668 Patent against Plaintiff's Wrist Roller products.
7. Ordering Defendant to return to the Court with proof of compliance of this Order within seven (7) days of entry thereof, with a copy served on Plaintiff's attorney.

8. Awarding Plaintiff damages due to Defendant's improper acts, doubled and/or trebled due to the willful and exceptional nature of the case.
9. Awarding Plaintiff compensatory, general and special, consequential and incidental damages in an amount to be determined at trial.
10. Awarding Plaintiff exemplary, punitive, statutory, and enhanced damages.
11. Awarding pre- and post- judgment interest.
12. Awarding Plaintiff such other and further relief as this Court deems is just and proper.

Jury Trial Demand

Plaintiff hereby demands a jury trial on all issues so triable.

Date: December 6, 2024

/s/ Ruoting Men

Ruoting Men, Esq.
GLACIER LAW LLP
41 Madison Avenue, Suite 2529
New York, NY 10010
Ruoting.men@glacier.law
212-729-5049
Attorney for Plaintiff