

**IN THE UNITED STATES DISTRICT COURT
FOR THE EASTERN DISTRICT OF TEXAS
MARSHALL DIVISION**

COMARCO WIRELESS SYSTEMS LLC,

Plaintiff,

v.

AT&T INC.,

Defendant.

C.A. No. 2:25-cv-00173

JURY TRIAL DEMANDED

PATENT CASE

ORIGINAL COMPLAINT FOR PATENT INFRINGEMENT

Plaintiff Comarco Wireless Systems LLC files this Original Complaint for Patent Infringement against AT&T Inc., and would respectfully show the Court as follows:

I. THE PARTIES

1. Plaintiff Comarco Wireless Systems LLC (“Comarco” or “Plaintiff”) is a Texas limited liability company, having a place of business located at 6000 Shepherd Mountain Cove, Suite #1604, Austin TX 78730.

2. On information and belief, Defendant AT&T Inc., (“Defendant”) is a corporation organized and existing under the laws of Delaware with a place of business at 1712 E Grand Avenue, Marshall, TX 75670. Defendant has a registered agent at CT Corporation System, 1999 Bryan St., Ste. 900, Dallas, TX 75201.

II. JURISDICTION AND VENUE

3. This action arises under the patent laws of the United States, Title 35 of the United States Code. This Court has subject matter jurisdiction of such action under 28 U.S.C. §§ 1331 and 1338(a).

4. On information and belief, Defendant is subject to this Court’s specific and general personal jurisdiction, pursuant to due process and the Texas Long-Arm Statute, due at least to its

business in this forum, including at least a portion of the acts of infringement alleged herein. Furthermore, Defendant is subject to this Court's specific and general personal jurisdiction because Defendant maintains places of business at 1712 E Grand Avenue, Marshall, TX 75670, 301 N Northwest Loop 323, Tyler, TX 75702, 2028 E Southeast Loop 323, Tyler, TX 75701, 4757 South Broadway Ave., Tyler, TX 75703, 1214 North US Highway 259, Suite 102, Kilgore, TX 75662, 109 W Loop 281 Longview, TX 75605, 3407 N 4th Street, Suite 107, Longview, TX 75605, 2306 Gilmer Road, Longview, TX 75604, and many more.

5. Without limitation, on information and belief, within this state, Defendant committed and continues to commit, acts of patent infringement, as alleged herein. In addition, on information and belief, Defendant has derived revenues from its infringing acts occurring within Texas. Further, on information and belief, Defendant is subject to the Court's general jurisdiction, including from regularly doing or soliciting business, engaging in other persistent courses of conduct, and deriving substantial revenue from services provided to persons or entities in Texas. Further, on information and belief, Defendant is subject to the Court's personal jurisdiction at least due to its providing services within Texas. Defendant has committed such purposeful acts and/or transactions in Texas such that it reasonably should know and expect that it could be haled into this Court as a consequence of such activity.

6. Venue is proper in this district under 28 U.S.C. § 1400(b). On information and belief, Defendant maintains places of business at 1712 E Grand Avenue, Marshall, TX 75670, 301 N Northwest Loop 323, Tyler, TX 75702, 2028 E Southeast Loop 323, Tyler, TX 75701, 4757 South Broadway Ave., Tyler, TX 75703, 1214 North US Highway 259, Suite 102, Kilgore, TX 75662, 109 W Loop 281 Longview, TX 75605, 3407 N 4th Street, Suite 107, Longview, TX 75605, 2306 Gilmer Road, Longview, TX 75604, and many more. On information and belief, from and

within this District, Defendant has committed and continues to commit at least a portion of the acts of infringement at issue in this case.

7. For these reasons, personal jurisdiction exists and venue is proper in this Court under 28 U.S.C. § 1400(b).

III. FACTUAL ALLEGATIONS UNDERLYING ALL CLAIMS

8. Plaintiff incorporates the above paragraphs herein by reference.

9. The patents at issue in this matter arose from the pioneering work of Thomas W. Lanni, an accomplished electrical engineer. Mr. Lanni began working in the field of power supply and conversion in the early 1980s. In 1994, Mr. Lanni joined Comarco, Inc. as Vice President and Chief Technology Officer.

10. Through his work at Comarco, Inc., Mr. Lanni recognized that the increasing use of a variety of portable devices and myriad power sources (e.g., automobile outlets and wall sockets) created the problem of a given device receiving the wrong level of power from a given power source. This mismatch could result in a failure to charge, or could cause damage to the device being charged by causing the battery to overheat or even catch fire.

11. To address this shortcoming in the prior art, Mr. Lanni invented a charging system whereby a charger and a portable electronic device engage in a “handshake” process in order to determine the appropriate level of power to be delivered to the portable electronic device. Mr. Lanni’s system includes a charger that comprises power circuitry to provide power along with data circuitry to receive a signal from the portable electronic device to be charged and to provide a signal in response. Conductors are configured to transfer DC power and a ground reference voltage to the portable electronic device. During operation, a third conductor receives the signal from the portable electronic device and a fourth conductor transmits the response signal to the portable electronic device. The portable electronic device is able to use this response signal to determine a

power level of the power supply system. This system enables the portable electronic device to receive the appropriate power level from the charger.

12. Mr. Lanni's work led to a large family of patent applications (and resulting issued patents) claiming priority to U.S. Patent Application No. 10/758,933 ("the '933 Application") filed on January 15, 2004. Mr. Lanni is the sole named inventor on these patents.

13. On July 16, 2013, U.S. Patent Application No. 13/943,453 was filed, claiming priority to U.S. Patent Application No 13/300,376. After examination, the USPTO issued U.S. Patent No. 9,413,187 ("the '187 Patent"), entitled "Power Supply System Providing Power and Analog Data Signal for Use by Portable Electronic Device to Control Battery Charging" on August 9, 2016. The term of the '187 patent has been adjusted by 381 days. A true and correct copy of the '187 Patent is attached as Exhibit 1.

14. On August 12, 2020, U.S. Patent Application No. 16/991,295 was filed, claiming priority to the '933 Application. After examination, the USPTO issued U.S. Patent No. 10,855,087 ("the '087 Patent"), entitled "Power Supply Systems" on December 1, 2020. A true and correct copy of the '087 Patent is attached as Exhibit 2.

15. On October 22, 2020, U.S. Patent Application No. 17/077,699 was filed, claiming priority to the '933 Application. After examination, the USPTO issued U.S. Patent No. 10,951,042 ("the '042 Patent"), entitled "Power Supply Systems" on March 16, 2021. A true and correct copy of the '042 Patent is attached as Exhibit 3.

16. Comarco is the assignee of all right, title, and interest in the '087 Patent, the '042 Patent, and the '187 Patent, (collectively "the Patents-in-Suit") including all rights to enforce and prosecute actions for infringement and to collect damages for all relevant times against infringers

of the Patents-in-Suit. Accordingly, Comarco possesses the exclusive right and standing to prosecute the present action for infringement of the Patents-in-Suit by Defendant.

IV. COUNT I
(PATENT INFRINGEMENT OF UNITED STATES PATENT NO. 9,413,187)

17. Upon information and belief, Defendant directly infringed claims 8 and 9, of the ‘187 patent (in Texas, and elsewhere in the United States), by making, using, selling, offering for sale and/or importing products including a power supply system, the power supply system being external to a portable electronic device and providing DC power, such products including, but not limited to, the following: AT&T Multi Port 72W Power Delivery Power Hub (USB-C + USB-A); AT&T Dual Port 32W Power Delivery Bullet Car Charger (USB-C + USB-A); AT&T Dual Port 40W Power Delivery Bullet Car Charger (USB-C + USB-C); AT&T Dual Port 32W Power Delivery Wall Block (USB-C + USB-A); AT&T Captive Cable Power Delivery Car Charger 40W with USB-C Port (USB-C); AT&T 10K Power Delivery Portable Battery with USB-C In/Out + USB-A Out; and AT&T Single Port 30W Power Delivery Wall Block USB-C (“‘187 Accused Chargers”).

18. Claim 8 of the ‘187 patent states:

A power supply system for providing DC power to a portable electronic device, the power supply system being external to the portable electronic device and comprising:

power circuitry to provide the DC power;

data circuitry to receive a first signal originating from the portable electronic device and to provide a second signal to the portable electronic device; and

a connector disposed on a cable end, the connector having four conductors for detachably mating with a power input opening of the portable electronic device, the first and second conductors transferring the DC power and its ground reference to the portable electronic device, the third conductor transferring the first signal from the portable electronic device to the data circuitry, and the fourth conductor transferring the second signal from the data circuitry to the portable electronic device,

wherein the data circuitry, in response to the first signal, provides the second signal to the portable electronic device, the second signal being an analog signal having a parameter level to indicate to the portable electronic device the potential power output level of the power supply system.

(Ex. A at 11:6-12:7).

A. Infringement for Compliance with the Battery Charging (BC) 1.2 specification

19. Defendant made, used, sold, offered for sale and/or imported products, such as the '187 Accused Chargers, that are or include a power supply system for providing DC power to a portable electronic device, the power supply system (*e.g.*, the '187 Accused Chargers) being external to the portable electronic device. Upon information and belief, the '187 Accused Chargers include circuitry compliant with the Battery Charging (BC) 1.2 specification to charge the portable electronic device. The Table 2-1 (<https://www.usb.org/sites/default/files/USB%20Type-C%20Spec%20R2.0%20-%20August%202019.pdf>, page 36) and the diagram depicting the power consumed by different USB specifications (<https://usb.org/sites/default/files/D2T2-1%20-%20USB%20Power%20Delivery.pdf>, page 5) disclose that BC 1.2 is used to output 5V voltage, 1.5A current, and 7.5W power. USB-compliant devices at USB 3.0 or above are compatible with the USB BC 1.2 specification.

< See all accessories



[Learn more about this accessory](#)

[Write a review](#)



AT&T USB Power Hub 72W with 4 ports (3 USB-C + 1 USB-A)

Special offers (1)

Earn up to \$440 back
AT&T Wireless customers enjoy an exclusive benefit with the AT&T Points Plus® Card from Citi. Terms apply. [Learn how](#)

Color: Black

Overview

With 72W of power, you can safely charge your laptop, phone, tablet, and other devices simultaneously. It's the perfect charger for your home or office, and its compact design and wall plug also makes it ideal for traveling.

Features:

- 3 USB-C ports and 1 USB-A port
- Compact design with wall plug
- Charges four devices at once
- 72W power charges laptops

(E.g., <https://www.att.com/buy/accessories/Chargers/att-usb-power-hub-72w-with-4-ports-3-usb-c-1-usb-a.html>).

ADDING A NEW DEVICE

Customize your accessory



1. Pick your accessory

2. Customize your accessory

3. Review your cart

Checkout

< See all accessories



★★★★★ 4.6 | 21 Write a review



AT&T Dual Port 32W Power Delivery Bullet Car Charger (USB-C + USB-A) **\$35.00**

Special offers (1)

Earn up to \$440 back
AT&T Wireless customers enjoy an exclusive benefit with the AT&T Points Plus® Card from Citi. Terms apply. [Learn how](#)

Color: Black



Overview

Easily plugs into your car's charging socket and delivers up to 32W of power to quickly charge your Apple and Android devices. The dual USB ports help power two devices fast and efficiently at the same time.

Features:

- Single USB-C port and single USB-A port
- Compact design with LED power indicator
- Charges two devices simultaneously
- Power delivery optimized for premium Android and Apple devices
- Output: USB-C Port (20W)
- 5VDC/3A; 9VDC/2.22A; 12VDC/1.67A
- PPS Output: 3.3-5.9VDC/3A; 3.3-11VDC/2.22A
- Output: USB-A Port (12W): 5VDC/2.4A
- Input: 12VDC
- USB Power Delivery 3.0 PPS
- 1-year limited warranty

(E.g., <https://www.att.com/buy/accessories/Chargers/att-dual-port-32w-power-delivery-bullet-car-charger-usb-c-plus-usb-a.html?q=usb%20c%20pd>).

ADDING A NEW DEVICE

Customize your accessory

1. Pick your accessory 2. Customize your accessory 3. Review your cart Checkout

< See all accessories



Write a review



AT&T Dual Port 40W Power Delivery Bullet Car Charger (USB-C + USB-C)

Special offers (1)

Earn up to \$440 back
AT&T Wireless customers enjoy an exclusive benefit with the AT&T Points Plus® Card from Citi. Terms apply. [Learn how](#)

Color: Black

Easily plugs into your car's charging socket and delivers up to 40W of power to quickly charge your Apple and Android devices. The dual USB ports help power two devices fast and efficiently at the same time.

Features:

- Dual USB-C ports
- Compact design with LED power indicator
- Charges two devices simultaneously
- Power delivery optimized for premium Android and Apple devices
- Output: USB-C Port (20W)
- 5VDC/3A; 9VDC/2.22A; 12VDC/1.67A
- PPS Output: 3.3-5.9VDC/3A; 3.3-11VDC/2.22A
- Output: USB-C Port (20W)
- 5VDC/3A; 9VDC/2.22A; 12VDC/1.67A
- PPS Output: 3.3-5.9VDC/3A; 3.3-11VDC/2.22A
- Input: 12VDC
- USB Power Delivery 3.0 PPS
- 1-year limited warranty

(E.g., <https://www.att.com/buy/accessories/Chargers/att-dual-port-40w-power-delivery-bullet-car-charger-usb-c-plus-usb-c.html?q=usb%20c%20pd>).

ADDING A NEW DEVICE

Customize your accessory

1. Pick your accessory 2. Customize your accessory 3. Review your cart Checkout

< See all accessories



Learn more about this accessory

Write a review



AT&T Dual Port 32W Power Delivery Wall Block (USB-C + USB-A)

Special offers (1)



Earn up to \$440 back

AT&T Wireless customers enjoy an exclusive benefit with the AT&T Points Plus® Card from Citi. Terms apply.

[Learn how](#)

Color: Black

With a compact design and foldable prongs, this charger easily fits into a purse or pocket and is convenient to take anywhere. The 32W of power safely charges your phone, tablet, and other devices simultaneously.

Features:

- Single USB-C port and Single USB-A port
- Foldable prongs
- Compact design
- Charges two devices simultaneously
- Power Delivery optimized for premium Android and Apple devices
- Output: USB-C (20W)
- 5VDC/3A; 9VDC/2.22A; 12VDC/1.67A
- PPS Output: 3.3-5.9VDC/3A; 3.3-11VDC/2.22A
- Output: USB-A (12W): 5VDC/2.4A
- Input: 100VAC – 240VAC
- USB Power Delivery 3.0 PPS
- 1-year limited warranty

(E.g., <https://www.att.com/buy/accessories/Chargers/att-dual-port-32w-power-delivery-wall-block-usb-c-plus-usb-a.html?q=usb%20c%20pd>).

ADDING A NEW DEVICE

Customize your accessory

1. Pick your accessory 2. Customize your accessory 3. Review your cart Checkout

< See all accessories



Write a review

AT&T Captive Cable Power Delivery Car Charger 40W with USB-C Port (USB-C)

Special offers (1)

Earn up to \$440 back
 AT&T Wireless customers enjoy an exclusive benefit with the AT&T Points Plus® Card from Citi. Terms apply. [Learn how](#)

Color: Black

Easily plugs into your car's charging socket and delivers up to 40W of power to quickly charge two devices simultaneously. Includes a 3-foot attached Type-C cable plus a Single USB-C port to charge all your compatible devices.

Features:

- Compact design with LED power indicator
- Charges two devices simultaneously
- Braided cable and aluminum connector provide extra durability
- Power delivery optimized for premium Android and Apple devices
- Output (each port)
- 5VDC/3A; 9VDC/2.22A; 12VDC/1.67A
- PPS Output: 3.3-5.9VDC/3A; 3.3-11VDC/2.22A
- Input: 12VDC
- USB Power Delivery 3.0 PPS
- 1-year limited warranty

(E.g., <https://www.att.com/buy/accessories/Chargers/att-captive-cable-power-delivery-car-charger-40w-with-usb-c-port-usb-c.html?q=usb%20c%20pd>).

[See all accessories](#)



[Write a review](#)



AT&T 10K Power Delivery Portable Battery with USB-C In/Out + USB-A Out

Special offers (1)



Earn up to \$440 back

AT&T Wireless customers enjoy an exclusive benefit with the AT&T Points Plus® Card from Citi. Terms apply.

[Learn how](#)

Color: Black

Simultaneously charge two devices at the same time while on-the-go to help keep you fully charged throughout the day. The LED indicator lights signify the charging status and current battery life so you know exactly how much power you have left.

Features:

- Single USB-C port + single USB-A port outputs
- Compact design
- Four LED indicators show battery power level
- Charges two devices simultaneously
- Power delivery output rapidly charges premium Android and Apple devices
- Power Delivery input rapidly re-charges the portable battery
- Output: USB-C (20W): 5VDC/3A; 9VDC/2.22A; 12VDC/1.67A
- USB-A: fast charge 18W
- Maximum 20W
- Input: USB-C 18W PD
- UL approved battery cell
- 1-year limited warranty

(E.g., <https://www.att.com/buy/accessories/Chargers/att-10k-power-delivery-portable-battery-with-usb-c-in-out-plus-usb-a-out.html?q=usb%20c%20pd>).

< See all accessories



[Learn more about this accessory](#)

★★★★★ 4.5 | 436 Write a review



AT&T Single Port 30W Power Delivery Wall Block USB-C \$31.99

Special offers (1)

Earn up to \$440 back
AT&T Wireless customers enjoy an exclusive benefit with the AT&T Points Plus® Card from Citi. Terms apply. [Learn how](#)

Color: Black



Available for pickup at our [Blackstone store](#)

FREE delivery by Feb 03

Overview ^

Your devices deserve a powerful and safe charging experience. This USB-C PD charger brings your battery back to life up to 80% faster than a standard charger. So you're never running on empty for too long.

Videos & images v

Customer Q & A v

Reviews v

Features & specs ^

Key Features

- Single USB-C port
- Foldable prongs
- Compact design

(E.g., <https://www.att.com/buy/accessories/Chargers/att-single-port-30w-power-delivery-wall-block-usb-c.html?q=usb%20c%20pd>).

Table 2-1 Summary of power supply options

Mode of Operation	Voltage	Current	Notes
USB 2.0	5 V	See USB 2.0	
USB 3.2	5 V	See USB 3.2	
USB4	5 V	1.5 A	See Section 5.3.
USB BC 1.2	5 V	1.5 A ¹	Legacy charging
USB Type-C Current @ 1.5 A	5 V	1.5 A	Supports higher power devices
USB Type-C Current @ 3.0 A	5 V	3 A	Supports higher power devices
USB PD	Configurable up to 20 V	Configurable up to 5 A	Directional control and power level management

(E.g., <https://www.usb.org/sites/default/files/USB%20Type-C%20Spec%20R2.0%20-%20August%202019.pdf>, page 36).

Our vision...

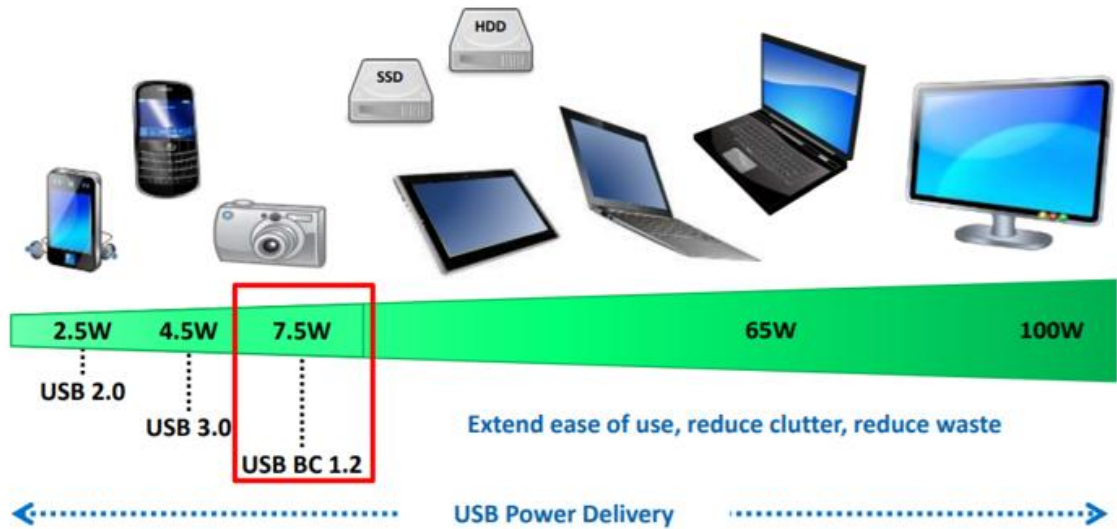

(E.g., <https://usb.org/sites/default/files/D2T2-1%20-%20USB%20Power%20Delivery.pdf>, page 5).

20. On information and belief, Defendant provided the ‘187 Accused Chargers which includes power circuitry to provide DC power. This element is met literally, or in the alternative, under the doctrine of equivalents. For example, to charge a portable electronic device, a USB cable is connected to the USB power supply. Further, the other end of the USB cable is connected to the charging port of a portable electronic device and the power supply is plugged into a standard wall socket. Therefore, the USB power supply comprises power circuitry to provide DC power to a portable electronic device.

3.2.4 Primary Detection

Primary Detection is used to distinguish between an SDP and different types of Charging Ports. A PD is required to implement Primary Detection.

3.2.4.1 Primary Detection, DCP

Figure 3-6 shows how Primary Detection works when a PD is attached to a DCP.

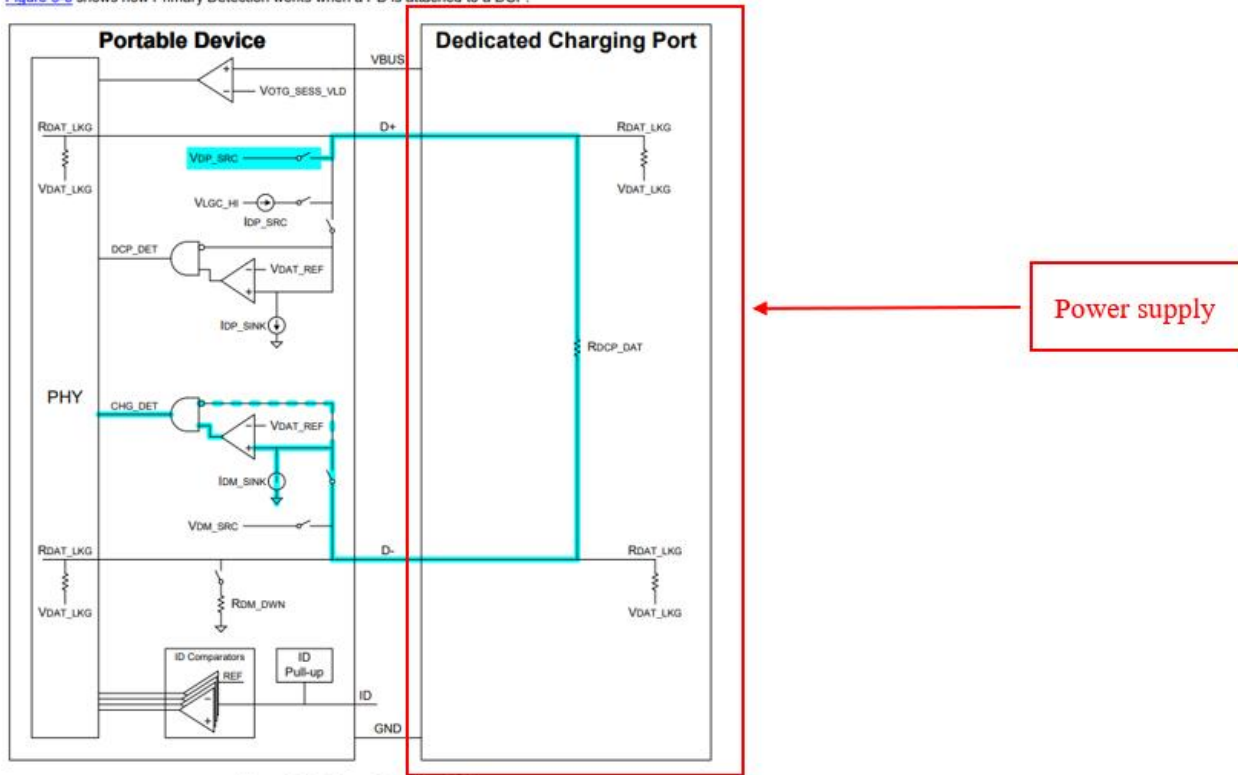

Figure 3-6 Primary Detection, DCP

(E.g., https://www.usb.org/sites/default/files/BCv1.2_070312_0.zip, USB Battery Charging Specification (Including errata and ECNs through March 15, 2012), Revision 1.2, March 15, 2012, Page 14).

21. Defendant provided a product or system, such as the '187 Accused Chargers, that include data circuitry to receive a first signal originating from the portable electronic device and to provide a second signal to the portable electronic device. This element is met literally, or in the alternative, under the doctrine of equivalents. For example, the USB power supply comprises data circuitry configured to use the Primary Detection method as described in the USB BC 1.2 specification. For example, during Primary Detection, when a portable electronic device is connected with the power supply through the USB cable, the portable electronic device generates a D+ signal ("first signal"). Data circuitry of the USB power supply receives a D+ signal ("first signal") and provides a D- signal ("second signal") to the portable electronic device to detect the type of connected power supply (standard downstream port or charging port). The D+ signal and D- signal are separate signals. The D+ signal originates at the portable electronic device and is received by the power supply. When the D+ signal passes through the resistor R_{DCP_DAT} , the resistance causes the voltage to drop, creating a new D- signal to be transmitted to the portable electronic device via the D- pin. Thus, the D+ signal is received by the power supply at one voltage and the D- signal is transmitted to the portable electronic device at a second voltage. To the extent the D- signal (*i.e.*, "second signal") is not found to literally satisfy this claim element because it is a modified signal originating in the portable electronic device, it satisfies this claim element under the doctrine of equivalents. The function of the D- signal is to inform the portable electronic device that the portable electronic device is to receive current from the power supply and charge its battery. Provided the D- signal is of the appropriate voltage, the portable electronic device interprets the D- signal received from the power supply as enabling battery charging regardless of the initial origin of the D- signal. The D- signal therefore performs the same function (informing the portable electronic device that it can receive current from the power supply for the purpose of

charging its battery) in the same way (by receiving a signal from the power supply) with the same result (the portable electronic device is able to charge its battery using the current from the power supply).

1.2 Background

The USB ports on personal computers are convenient places for Portable Devices (PDs) to draw current for charging their batteries. This convenience has led to the creation of USB Chargers that simply expose a USB standard-A receptacle. This allows PDs to use the same USB cable to charge from either a PC or from a USB Charger.

If a PD is attached to a USB host or hub, then the USB 2.0 specification requires that after connecting, a PD must draw less than:

- 2.5 mA average if the bus is suspended
- 100 mA if bus is not suspended and not configured
- 500 mA if bus is not suspended and configured for 500 mA

If a PD is attached to a Charging Port, (i.e. CDP, DCP, ACA-Dock or ACA), then it is allowed to draw `IDEV_CHG` without having to be configured or follow the rules of suspend.

In order for a PD to determine how much current it is allowed to draw from an upstream USB port, there need to be mechanisms that allow the PD to distinguish between a Standard Downstream Port and a Charging Port. This specification defines just such mechanisms.

Since PDs can be attached to USB chargers from various manufacturers, it is important that all provide an acceptable user experience. This specification defines the requirements for a compliant USB charger, which is referred to in this spec as a USB Charger.

(E.g., https://www.usb.org/sites/default/files/BCv1.2_070312_0.zip, USB Battery Charging Specification (Including errata and ECNs through March 15, 2012), Revision 1.2, March 15, 2012, Page 1).

3.2.4 Primary Detection

Primary Detection is used to distinguish between an SDP and different types of Charging Ports. A PD is required to implement Primary Detection.

3.2.4.1 Primary Detection, DCP

Figure 3-6 shows how Primary Detection works when a PD is attached to a DCP.

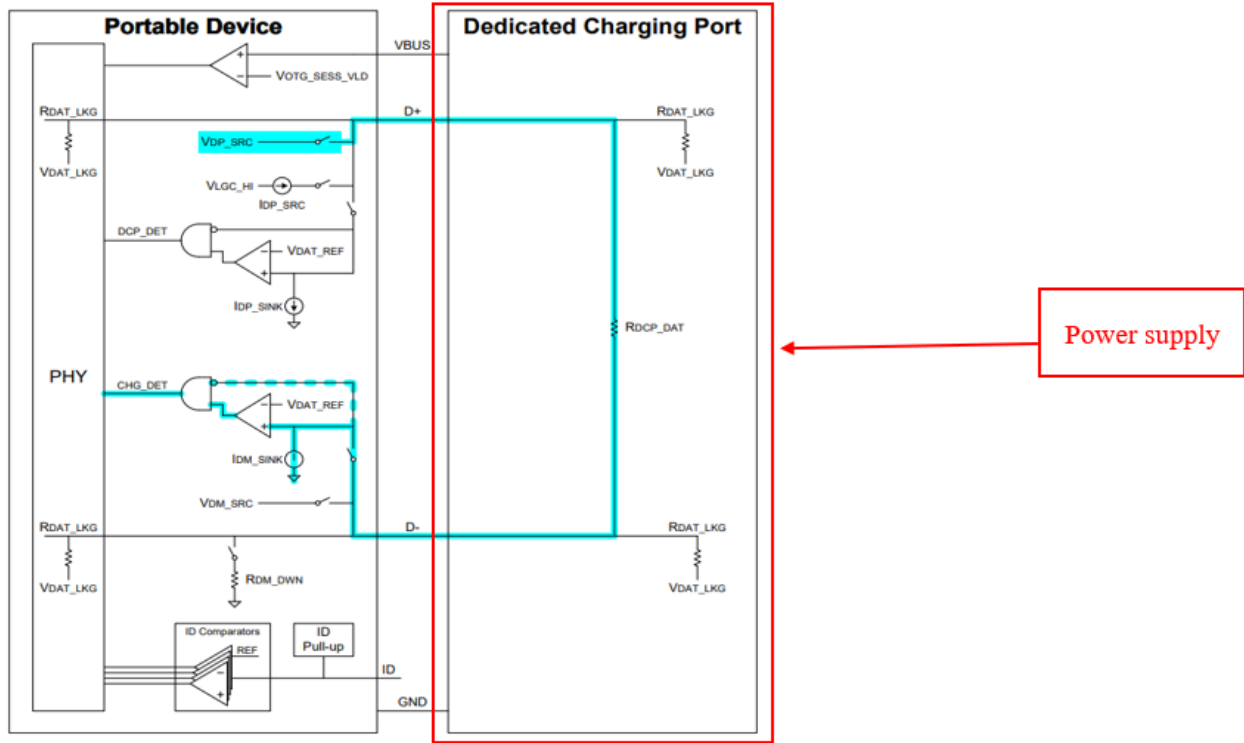

Figure 3-6 Primary Detection, DCP

(E.g., https://www.usb.org/sites/default/files/BCv1.2_070312_0.zip, USB Battery Charging Specification (Including errata and ECNs through March 15, 2012), Revision 1.2, March 15, 2012, Page 14).

During Primary Detection the PD shall turn on V_{DP_SRC} and IDM_SINK . Since a DCP is required to short D+ to D- through a resistance of R_{DCP_DAT} , the PD will detect a voltage on D- that is close to V_{DP_SRC} .

A PD shall compare the voltage on D- with V_{DAT_REF} . If D- is greater than V_{DAT_REF} , then the PD is allowed to detect that it is attached to either a DCP or CDP. A PD is optionally allowed to compare D- with V_{LGC} as well, and only determine that it is attached to a DCP or CDP if D- is greater than V_{DAT_REF} , but less than V_{LGC} . The reason for this option is as follows.

PS2 ports pull D+/- high. If a PD is attached to a PS2 port, and the PD only checks for D- greater than V_{DAT_REF} , then a PD attached to a PS2 port would determine that it is attached to a DCP or CDP and proceed to draw I_{DEV_CHG} . This much current could potentially damage a PS2 port. By only determining it is attached to DCP or CDP if D- is less than V_{LGC} , the PD can avoid causing damage to a PS2 port.

On the other hand, some proprietary chargers also pull D+/- high. If a PD is attached to one of these chargers, and it determined it was not attached to a charger because D- was greater than V_{LGC} , then the PD would determine that it was attached to an SDP, and only be able to draw I_{SUSP} .

The choice of whether or not to compare D- to V_{LGC} depends on whether the PD is more likely to be attached to a PS2 port, or to a proprietary charger.

(E.g., https://www.usb.org/sites/default/files/BCv1.2_070312_0.zip, USB Battery Charging Specification (Including errata and ECNs through March 15, 2012), Revision 1.2, March 15, 2012, Page 15).

22. Defendant provided a product or system, such as the ‘187 Accused Chargers, that include a connector disposed on a cable end, the connector having four conductors for detachably mating with a power input opening of the portable electronic device, the first and second conductors transferring the DC power and its ground reference to the portable electronic device, the third conductor transferring the first signal from the portable electronic device to the data circuitry, and the fourth conductor transferring the second signal from the data circuitry to the portable electronic device. This element is met literally, or in the alternative, under the doctrine of equivalents. For example, the USB power supply connects to the portable electronic device through a USB cable. The USB cable has a USB-C connector at one end to detachably mate with the charging port of a portable electronic device. The connector comprises VBUS (“first conductor”), GND (“second conductor”), D+ (“third conductor”) and D- (“fourth conductor”) pins. The VBUS pin is the voltage line that provides DC power to the portable electronic device and

GND pin provides a ground reference to the portable electronic device. The D+ pin provides the D+ signal (“first signal”) from the portable electronic device to the data circuitry of the USB power supply and the D- pin provides the D- signal (“second signal”) from the data circuitry of the USB power supply to the portable electronic device. To the extent the D- signal (*i.e.*, “second signal”) is not found to literally satisfy this claim element because it is a modified signal originating in the portable electronic device, it satisfies this claim element under the doctrine of equivalents. The function of the D- signal is to inform the portable electronic device that the portable electronic device is to receive current from the power supply and charge its battery. Provided the D- signal is of the appropriate voltage, the portable electronic device interprets the D- signal received from the power supply as enabling battery charging regardless of the initial origin of the D- signal. The D- signal therefore performs the same function (informing the portable electronic device that it can receive current from the power supply for the purpose of charging its battery) in the same way (by receiving a signal from the power supply) with the same result (the portable electronic device is able to charge its battery using the current from the power supply).

3.2.3.2 Problem Description

USB plugs and receptacles are designed such that when the plug is inserted into the receptacle, the power pins make contact before the data pins make contact. This is illustrated in [Figure 3-3](#).

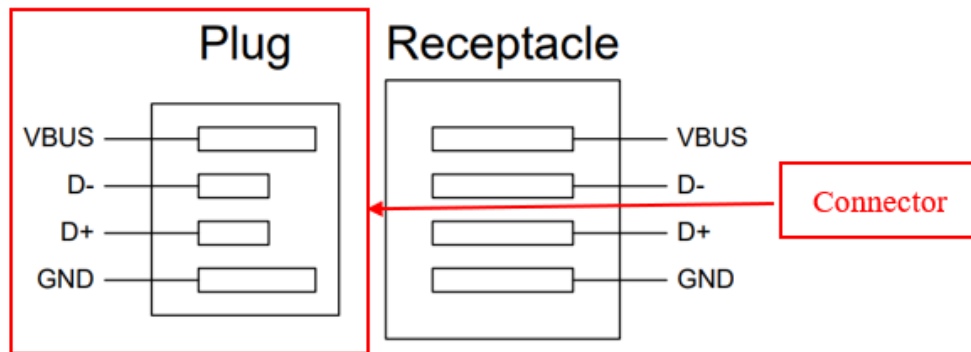

Figure 3-3 Data Pin Offset

(E.g., https://www.usb.org/sites/default/files/BCv1.2_070312_0.zip, USB Battery Charging Specification (Including errata and ECNs through March 15, 2012), Revision 1.2, March 15, 2012, Page 10).

3. Charging Port Detection

3.1 Overview

Figure 3-1 shows several examples of a PD attached to an SDP or Charging Port.

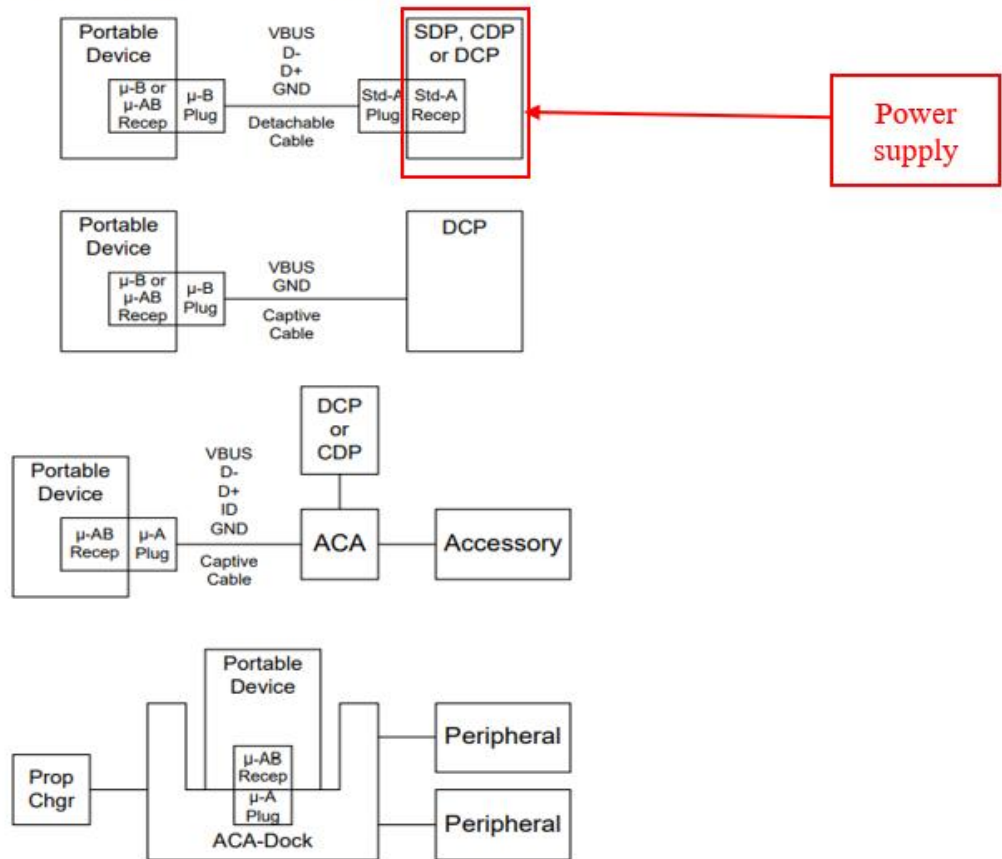

Figure 3-1 System Overview

(E.g., https://www.usb.org/sites/default/files/BCv1.2_070312_0.zip, USB Battery Charging Specification (Including errata and ECNs through March 15, 2012), Revision 1.2, March 15, 2012, Page 6).

3.5 Ground Current and Noise Margins

As shown in Figure 7-47 of the USB 2.0 specification, a current of 100 mA through the ground wire of a USB cable can result in a voltage difference of 25 mV between the host ground and the device ground. This ground difference has the effect of reducing noise margins for both signaling and charger detection.

(E.g., https://www.usb.org/sites/default/files/BCv1.2_070312_0.zip, USB Battery Charging Specification (Including errata and ECNs through March 15, 2012), Revision 1.2, March 15, 2012, Page 36).

Acronyms

ACA	Accessory Charger Adapter
CDP	Charging Downstream Port
DBP	Dead Battery Provision
DCD	Data Contact Detect
DCP	Dedicated Charging Port
FS	Full Speed
HS	High-Speed
LS	Low-Speed
OTG	On-The-Go
PC	Personal Computer
PD	Portable Device
PHY	Physical Layer Interface for High-Speed USB
PS2	Personal System 2
SDP	Standard Downstream Port
SRP	Session Request Protocol
TPL	Targeted Peripheral List
USB	Universal Serial Bus
USBCV	USB Command Verifier
USB-IF	USB Implementers Forum
<u>VBUS</u>	<u>Voltage line of the USB interface</u>

(E.g., https://www.usb.org/sites/default/files/BCv1.2_070312_0.zip, USB Battery Charging Specification (Including errata and ECNs through March 15, 2012), Revision 1.2, March 15, 2012, Page xi).

3.2.4 Primary Detection

Primary Detection is used to distinguish between an SDP and different types of Charging Ports. A PD is required to implement Primary Detection.

3.2.4.1 Primary Detection, DCP

Figure 3-6 shows how Primary Detection works when a PD is attached to a DCP.

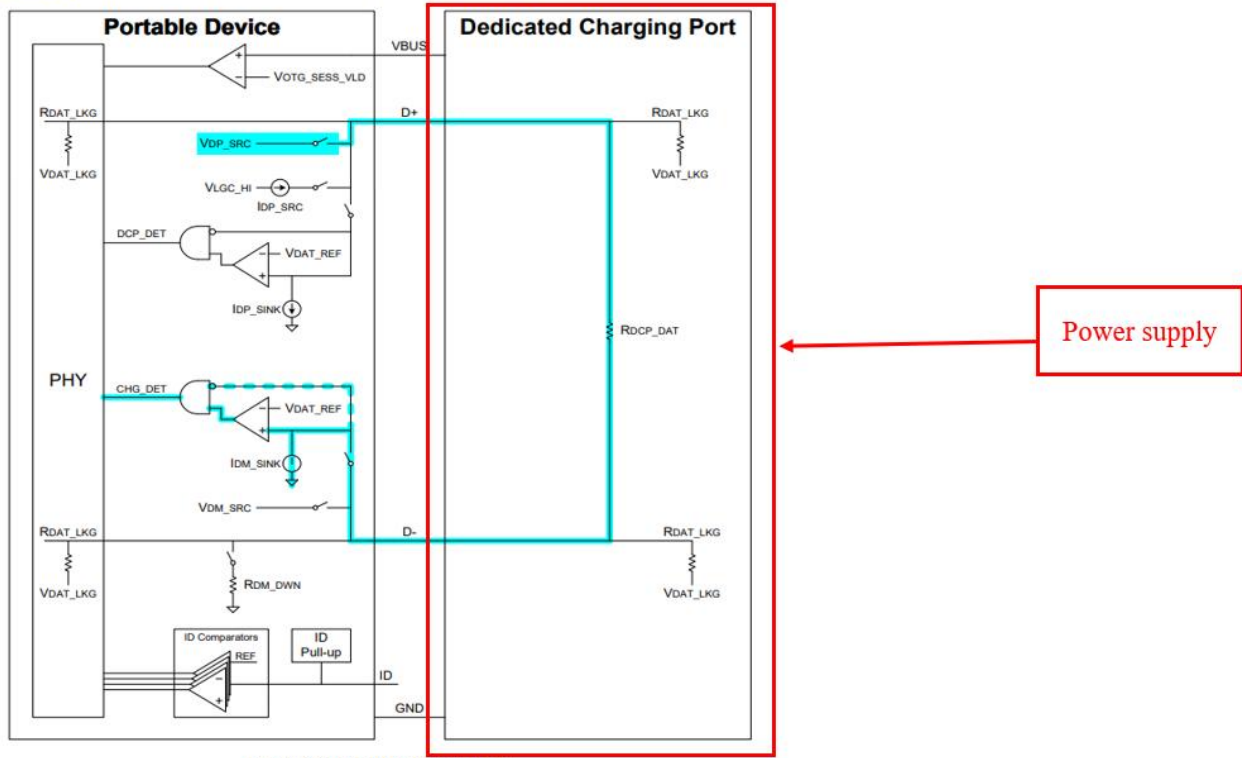

Figure 3-6 Primary Detection, DCP

(E.g., https://www.usb.org/sites/default/files/BCv1.2_070312_0.zip, USB Battery Charging Specification (Including errata and ECNs through March 15, 2012), Revision 1.2, March 15, 2012, Page 14).

During Primary Detection the PD shall turn on [VDP_SRC](#) and [IDM_SINK](#). Since a DCP is required to short D+ to D- through a resistance of [RDCP_DAT](#), the PD will detect a voltage on D- that is close to [VDP_SRC](#).

A PD shall compare the voltage on D- with [VDAT_REF](#). If D- is greater than [VDAT_REF](#), then the PD is allowed to detect that it is attached to either a DCP or CDP. A PD is optionally allowed to compare D- with [VLGC](#) as well, and only determine that it is attached to a DCP or CDP if D- is greater than [VDAT_REF](#), but less than [VLGC](#). The reason for this option is as follows.

PS2 ports pull D+/- high. If a PD is attached to a PS2 port, and the PD only checks for D- greater than [VDAT_REF](#), then a PD attached to a PS2 port would determine that it is attached to a DCP or CDP and proceed to draw [IDEV_CHG](#). This much current could potentially damage a PS2 port. By only determining it is attached to DCP or CDP if D- is less than [VLGC](#), the PD can avoid causing damage to a PS2 port.

On the other hand, some proprietary chargers also pull D+/- high. If a PD is attached to one of these chargers, and it determined it was not attached to a charger because D- was greater than [VLGC](#), then the PD would determine that it was attached to an SDP, and only be able to draw [ISUSP](#).

The choice of whether or not to compare D- to [VLGC](#) depends on whether the PD is more likely to be attached to a PS2 port, or to a proprietary charger.

(E.g., https://www.usb.org/sites/default/files/BCv1.2_070312_0.zip, USB Battery Charging Specification (Including errata and ECNs through March 15, 2012), Revision 1.2, March 15, 2012, Page 15).

> MINI & MICRO USB CONNECTOR PIN CONNECTIONS

PIN	WIRE COLOUR	SIGNAL NAMES
1	Red	Vbus (4.75 - 5.25 V)
2	White	Data -
3	Green	Data +
4		Not connected, although it can sometimes be ground or used as a presence indicator.
5	Black	Ground
Shell	Drain wire	Shield

TYPE A & B USB CONNECTOR PIN CONNECTIONS

PIN	WIRE COLOUR	SIGNAL NAMES
1	Red	Vbus (4.75 - 5.25 V)
2	White	Data -
3	Green	Data +
4	Black	Ground
Shell	Drain wire	Shield

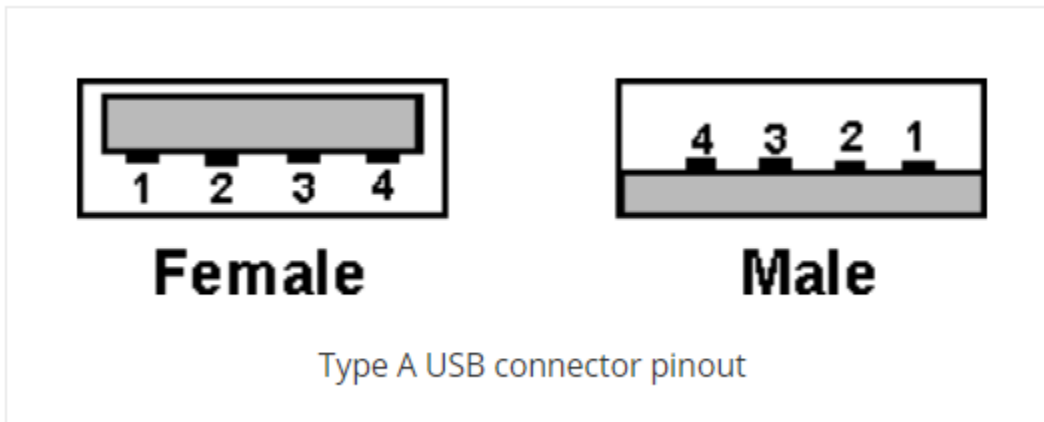

(E.g., <https://www.electronics-notes.com/articles/connectivity/usb-universal-serial-bus/connectors-pinouts-cables.php>).

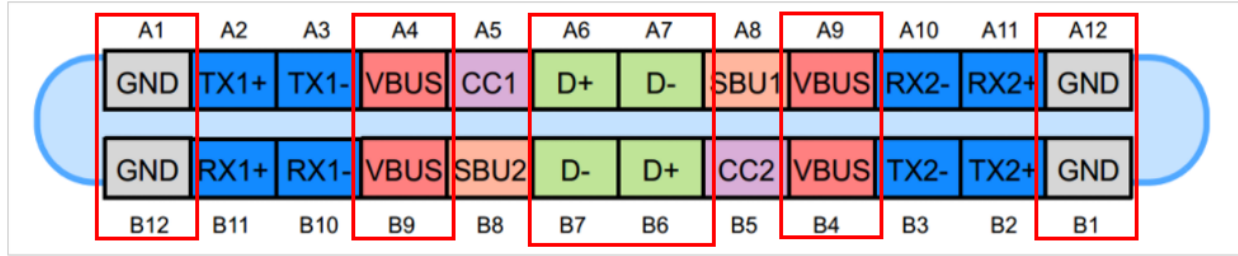

Figure 1. The USB Type-C receptacle. Image courtesy of Microchip.

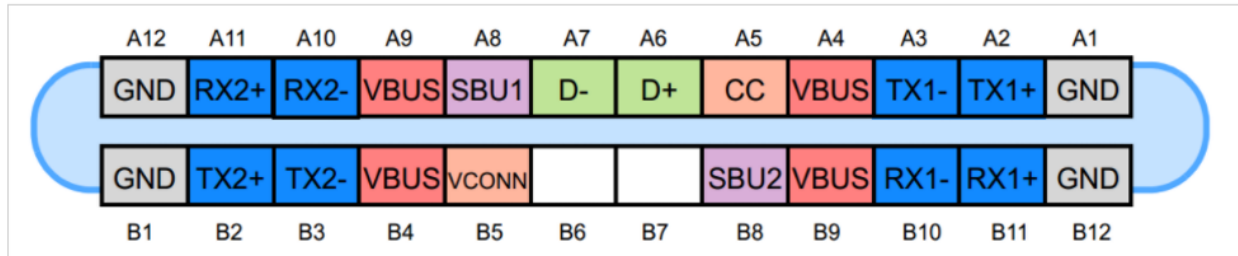

Figure 2. The USB Type-C plug. Image courtesy of Microchip.

(E.g., <https://www.allaboutcircuits.com/technical-articles/introduction-to-usb-type-c-which-pins-power-delivery-data-transfer/>).

23. Defendant provided a product or system with data circuitry, such as in ‘187 Accused Chargers, that in response to the first signal, provides the second signal to the portal electronic device, the second signal being an analog signal having a parameter level to indicate to the portable electronic device the potential power output level of the power supply system. This element is met literally, or in the alternative, under the doctrine of equivalents. For example, as described above, the USB power supply comprises data circuitry configured to use the Primary Detection method of the USB BC 1.2 specification. The USB power supply shorts the D+ to D- through a resistance of RDCP_DAT, such that in response to the D+ signal (“first signal”), the data circuitry of the power supply provides the D- signal (“second signal”) to the portable electronic device. The portable electronic device compares the D- signal’s voltage (“parameter”) level with a reference voltage to indicate the potential power output level of the connected power

supply. Therefore, the D- signal is an analog signal. To the extent the D- signal (*i.e.*, “second signal”) is not found to literally satisfy this claim element because it is a modified signal originating in the portable electronic device, it satisfies this claim element under the doctrine of equivalents. The function of the D- signal is to inform the portable electronic device that the portable electronic device is to receive current from the power supply and charge its battery. Provided the D- signal is of the appropriate voltage, the portable electronic device interprets the D- signal received from the power supply as enabling battery charging regardless of the initial origin of the D- signal. The D- signal therefore performs the same function (informing the portable electronic device that it can receive current from the power supply for the purpose of charging its battery) in the same way (by receiving a signal from the power supply) with the same result (the portable electronic device is able to charge its battery using the current from the power supply).

USB battery charging specifications

Battery Charging Specification Revision 1.2 (BC1.2)

The different port types described in the above section were first defined in the *Battery Charging Specification Revision 1.2 (BC1.2)* published in 2010. In addition to the port definitions, BC1.2 specifies primary and secondary charge port detection sequences and port specific performance requirements. These include required operating range, undershoot, detection signaling, and connectors for each port type. Also included are dead, weak, and good battery charge conditions, port shutdown procedures, and other details associated with battery charging.

BC1.2 was published after USB 2.0 but before USB 3.1 and so the information in BC1.2 refers to USB 2.0. The specification is, however, consistent and compatible with USB 3.1.

(E.g., https://www.lightingglobal.org/wp-content/uploads/2017/12/Issue-24_USB-smartphone-charging-final.pdf, page 4).

1.2 Background

The USB ports on personal computers are convenient places for Portable Devices (PDs) to draw current for charging their batteries. This convenience has led to the creation of USB Chargers that simply expose a USB standard-A receptacle. This allows PDs to use the same USB cable to charge from either a PC or from a USB Charger.

If a PD is attached to a USB host or hub, then the USB 2.0 specification requires that after connecting, a PD must draw less than:

- 2.5 mA average if the bus is suspended
- 100 mA if bus is not suspended and not configured
- 500 mA if bus is not suspended and configured for 500 mA

If a PD is attached to a Charging Port, (i.e. CDP, DCP, ACA-Dock or ACA), then it is allowed to draw IDEV_CHG without having to be configured or follow the rules of suspend.

In order for a PD to determine how much current it is allowed to draw from an upstream USB port, there need to be mechanisms that allow the PD to distinguish between a Standard Downstream Port and a Charging Port. This specification defines just such mechanisms.

Since PDs can be attached to USB chargers from various manufacturers, it is important that all provide an acceptable user experience. This specification defines the requirements for a compliant USB charger, which is referred to in this spec as a USB Charger.

(E.g., https://www.usb.org/sites/default/files/BCv1.2_070312_0.zip, USB Battery Charging Specification (Including errata and ECNs through March 15, 2012), Revision 1.2, March 15, 2012, Page 1).

3.2.4 Primary Detection

Primary Detection is used to distinguish between an SDP and different types of Charging Ports. A PD is required to implement Primary Detection.

3.2.4.1 Primary Detection, DCP

Figure 3-6 shows how Primary Detection works when a PD is attached to a DCP.

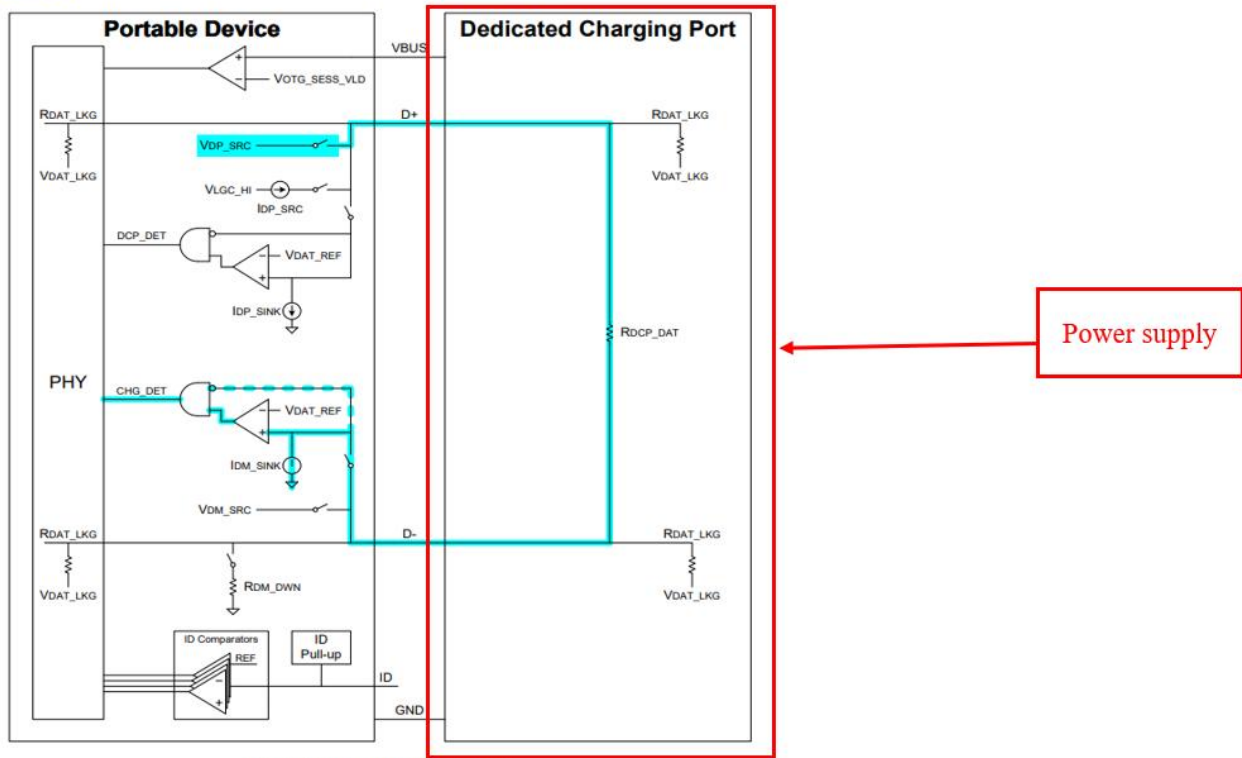

Figure 3-6 Primary Detection, DCP

(E.g., https://www.usb.org/sites/default/files/BCv1.2_070312_0.zip, USB Battery Charging Specification (Including errata and ECNs through March 15, 2012), Revision 1.2, March 15, 2012, Page 14).

During Primary Detection the PD shall turn on V_{DP_SRC} and I_{DM_SINK} . Since a DCP is required to short D+ to D- through a resistance of R_{DCP_DAT} , the PD will detect a voltage on D- that is close to V_{DP_SRC} .

A PD shall compare the voltage on D- with V_{DAT_REF} . If D- is greater than V_{DAT_REF} , then the PD is allowed to detect that it is attached to either a DCP or CDP. A PD is optionally allowed to compare D- with V_{LGC} as well, and only determine that it is attached to a DCP or CDP if D- is greater than V_{DAT_REF} , but less than V_{LGC} . The reason for this option is as follows.

PS2 ports pull D+/- high. If a PD is attached to a PS2 port, and the PD only checks for D- greater than V_{DAT_REF} , then a PD attached to a PS2 port would determine that it is attached to a DCP or CDP and proceed to draw I_{DEV_CHG} . This much current could potentially damage a PS2 port. By only determining it is attached to DCP or CDP if D- is less than V_{LGC} , the PD can avoid causing damage to a PS2 port.

On the other hand, some proprietary chargers also pull D+/- high. If a PD is attached to one of these chargers, and it determined it was not attached to a charger because D- was greater than V_{LGC} , then the PD would determine that it was attached to an SDP, and only be able to draw I_{SUSP} .

The choice of whether or not to compare D- to V_{LGC} depends on whether the PD is more likely to be attached to a PS2 port, or to a proprietary charger.

(E.g., https://www.usb.org/sites/default/files/BCv1.2_070312_0.zip, USB Battery Charging Specification (Including errata and ECNs through March 15, 2012), Revision 1.2, March 15, 2012, Page 15).

> MINI & MICRO USB CONNECTOR PIN CONNECTIONS

PIN	WIRE COLOUR	SIGNAL NAMES
1	Red	Vbus (4.75 - 5.25 V)
2	White	Data -
3	Green	Data +
4		Not connected, although it can sometimes be ground or used as a presence indicator.
5	Black	Ground
Shell	Drain wire	Shield

TYPE A & B USB CONNECTOR PIN CONNECTIONS

PIN	WIRE COLOUR	SIGNAL NAMES
1	Red	Vbus (4.75 - 5.25 V)
2	White	Data -
3	Green	Data +
4	Black	Ground
Shell	Drain wire	Shield

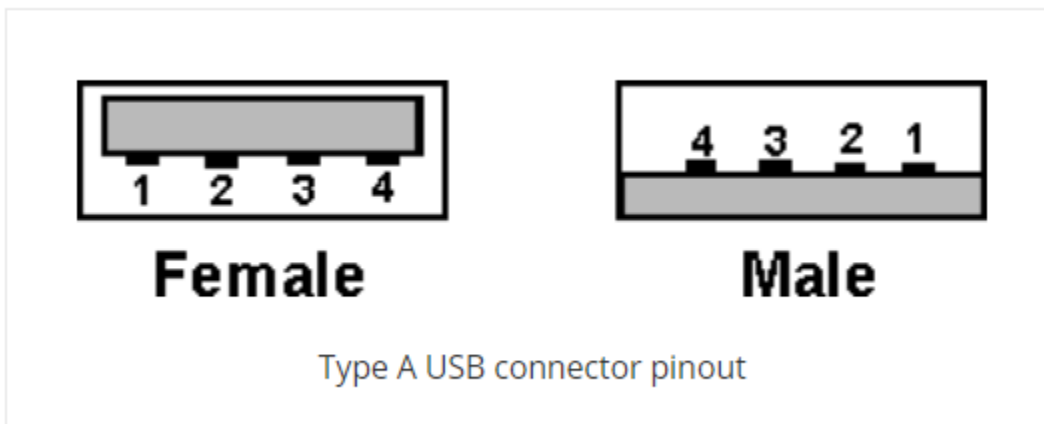

(E.g., <https://www.electronics-notes.com/articles/connectivity/usb-universal-serial-bus/connectors-pinouts-cables.php>).

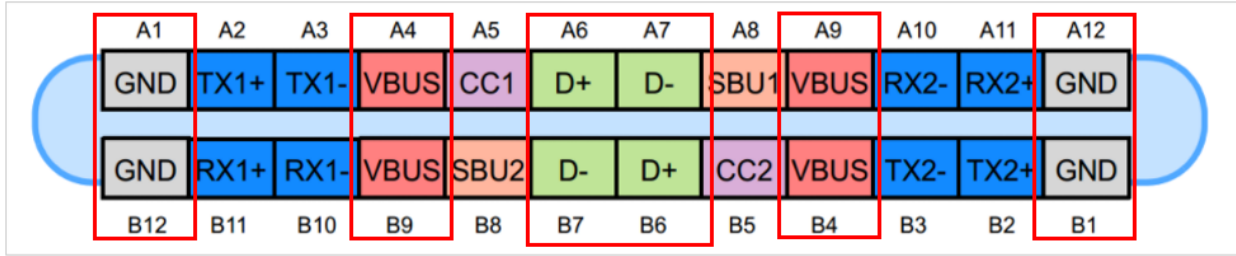

Figure 1. The USB Type-C receptacle. Image courtesy of Microchip.

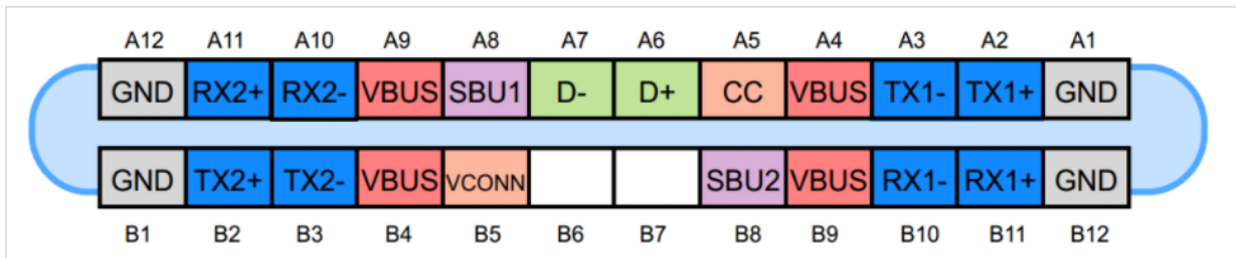

Figure 2. The USB Type-C plug. Image courtesy of Microchip.

(E.g., <https://www.allaboutcircuits.com/technical-articles/introduction-to-usb-type-c-which-pins-power-delivery-data-transfer/>).

24. Defendant provided a product or system, including the ‘187 Accused Chargers, in which the power circuitry of the power supply system converts power from an external power source to DC power. For example, to charge a portable electronic device, a USB cable is connected to the external USB power supply. Further, the other end of a USB cable is connected to the charging port of the portable electronic device and the power supply is plugged into a standard wall socket. Therefore, the external USB power supply system comprises power circuitry to provide DC power to the portable electronic device.

B. Infringement for Compliance with Power Delivery Standard

25. Upon information and belief, Defendant directly infringed claims 8 and 9, of the ‘187 patent (in Texas, and elsewhere in the United States), by making, using, selling, offering for sale and/or importing products including a power supply system, the power supply system being

external to a portable electronic device and providing DC power, such products including, but not limited to, the following: AT&T Multi Port 72W Power Delivery Power Hub (USB-C + USB-A); AT&T Dual Port 32W Power Delivery Bullet Car Charger (USB-C + USB-A); AT&T Dual Port 40W Power Delivery Bullet Car Charger (USB-C + USB-C); AT&T Dual Port 32W Power Delivery Wall Block (USB-C + USB-A); AT&T Captive Cable Power Delivery Car Charger 40W with USB-C Port (USB-C); and AT&T Single Port 30W Power Delivery Wall Block USB-C which comply with Universal Serial Bus Power Delivery Specification, Revision 2.0 January 2017. (“‘187 Accused PD Chargers”).

26. Defendant made, used, sold, offered for sale and/or imported products including the ‘187 Accused PD Chargers, that include a power supply system for providing DC power to a portable electronic device, the power supply system (*e.g.*, the ‘187 Accused PD Chargers) being external to the portable electronic device. Upon information and belief, the ‘187 Accused PD Chargers include circuitry that is compliant with at least Universal Serial Bus Type-C Cable and Connector Specification, Release 1.0 August 2014 (along with other subsequent revisions of Type-C specification), and Universal Serial Bus Power Delivery Specification, Revision 2.0 January 2017.

27. On information and belief, Defendant provided the ‘187 Accused PD Chargers which includes power circuitry to provide DC power. This element is met literally, or in the alternative, under the doctrine of equivalents. For example, to charge a portable electronic device, a USB cable is connected to the USB power supply. Further, the other end of the USB cable is connected to the charging port of a portable electronic device and the power supply is plugged into a standard wall socket. Therefore, the USB power supply comprises power circuitry to provide DC power to a portable electronic device.

28. Defendant provided a product or system, such as the ‘187 Accused PD Chargers, that include data circuitry to receive a first signal originating from the portable electronic device and to provide a second signal to the portable electronic device. This element is met literally, or in the alternative, under the doctrine of equivalents. For example, a portable device provides a CC1/CC2 signal (“first signal”) through the USB-C port to configure the device and transfer data. For example, in response to the CC1/CC2 signal (“first signal”), the data circuitry of the ‘187 Accused PD Charger provides RX signal (“second signal”) to the portable electronic device to configure the device and transfer data. The RX signal is an analog signal such that the signals are able to assume a plurality of voltages.

The USB Type-C receptacle, plug and cable designs are intended to support future USB functional extensions. As such, consideration was given to frequency scaling performance, pin-out arrangement and the configuration mechanisms when developing this solution. The definition of future USB functional extensions is not in the scope of this specification but rather will be provided in future releases of the base USB Specification, i.e., beyond the existing [USB 3.1 Specification](#).

Figure 2-1 illustrates the comprehensive functional signal plan for the USB Type-C receptacle, not all signals shown are required in all platforms or devices. As shown, the receptacle signal list functionally delivers both [USB 2.0](#) (D+ and D-) and [USB 3.1](#) (TX and RX pairs) data buses, USB power (VBUS) and ground (GND), [Configuration Channel](#) signals (CC1 and CC2), and two Sideband Use (SBU) signal pins. Multiple sets of USB data bus signal locations in this layout facilitate being able to functionally map the USB signals independent of plug orientation in the receptacle. For reference, the signal pins are labeled.

(E.g., <https://www.those.ch/designtechnik/wp-content/uploads/2014/08/USB-Type-C-Specification-Release-1.0.pdf>, Universal Serial Bus Type-C Cable and Connector Specification, Release 1.0 August 2014, Page 18).

Figure 2-1 USB Type-C Receptacle Interface (Front View)

A1	A2	A3	A4	A5	A6	A7	A8	A9	A10	A11	A12
GND	TX1+	TX1-	VBUS	CC1	D+	D-	SBU1	VBUS	RX2-	RX2+	GND
GND	RX1+	RX1-	VBUS	SBU2	D-	D+	CC2	VBUS	TX2-	TX2+	GND
B12	B11	B10	B9	B8	B7	B6	B5	B4	B3	B2	B1

(E.g., <https://www.those.ch/designtechnik/wp-content/uploads/2014/08/USB-Type-C-Specification-Release-1.0.pdf>, Universal Serial Bus Type-C Cable and Connector Specification, Release 1.0 August 2014, Page 18).

To establish the proper routing of the active USB data bus from DFP to UFP, the standard USB Type-C cable is wired such that a single CC wire is position aligned with the first USB SuperSpeed signal pairs (SSTXp1/SSTXn1 and SSRXp1/SSRXn1) – in this way, the CC wire and USB SuperSpeed data bus wires that are used for signaling within the cable track with regard to the orientation and twist of the cable. By being able to detect which of the CC pins (CC1 or CC2) at the receptacle is terminated by the UFP, the DFP is able to determine which SuperSpeed USB signals are to be used for the connection and the DFP can use this to control the functional switch for routing the SuperSpeed USB signal pairs. Similarly in the UFP, detecting which of the CC pins at the receptacle is terminated by the DFP allows the UFP to control the functional switch that routes its SuperSpeed USB signal pairs.

(E.g., <https://www.those.ch/designtechnik/wp-content/uploads/2014/08/USB-Type-C-Specification-Release-1.0.pdf>, Universal Serial Bus Type-C Cable and Connector Specification, Release 1.0 August 2014, Page 105).

5.2 Physical Layer Functions

The USB PD Physical Layer consists of a pair of transmitters and receivers that communicate across a single signal wire (V_{BUS} or CC). All communication is half duplex. The PHY Layer practices collision avoidance to minimize communication errors on the channel.

(E.g., <https://usb.org/sites/default/files/USB%20Power%20Delivery%2020210706.zip>, Universal Serial Bus Power Delivery Specification, Revision 2.0 Release January 2017, Page 104).

2.3 Configuration Process

The USB Type-C receptacle, plug and cable solution incorporates a configuration process to detect a downstream facing port to upstream facing port (DFP-to-UFP) connection for V_{BUS} management and host-to-device connected relationship determination.

The configuration process is used for the following:

- DFP-to-UFP attach/detach detection
- Plug orientation/cable twist detection
- Initial DFP-to-UFP (host-to-device) and power relationships detection
- USB Type-C V_{BUS} current detection and usage
- [USB PD](#) communication
- Discovery and configuration of functional extensions

(E.g., <https://www.those.ch/designtechnik/wp-content/uploads/2014/08/USB-Type-C-Specification-Release-1.0.pdf>, Universal Serial Bus Type-C Cable and Connector Specification, Release 1.0 August 2014, Page 20).

2.3.1 DFP-to-UFP Attach/Detach Detection

Initially, DFP-to-UFP attach is detected by a host or hub port (DFP) when one of the CC pins at its USB Type-C receptacle senses a specified resistance to GND. Subsequently, DFP-to-UFP detach is detected when the CC pin that was terminated at its USB Type-C receptacle is no longer terminated to GND.

Power is not applied to the USB Type-C host or hub receptacle (VBUS or VCONN) until the DFP detects the presence of an attached device (UFP) port. When a DFP-to-UFP attach is detected, the DFP is expected to enable power to the receptacle and proceed to normal USB operation with the attached device. When a DFP-to-UFP detach is detected, the port sourcing VBUS removes power.

(E.g., <https://www.those.ch/designtechnik/wp-content/uploads/2014/08/USB-Type-C-Specification-Release-1.0.pdf>, Universal Serial Bus Type-C Cable and Connector Specification, Release 1.0 August 2014, Page 21).

2.3.2 Plug Orientation/Cable Twist Detection

The USB Type-C plug can be inserted into a receptacle in either one of two orientations, therefore the CC pins enable a method for detecting plug orientation in order to determine which SuperSpeed USB data signal pairs are functionally connected through the cable. This allows for signal routing, if needed, within a DFP or UFP to be established for a successful connection.

(E.g., <https://www.those.ch/designtechnik/wp-content/uploads/2014/08/USB-Type-C-Specification-Release-1.0.pdf>, Universal Serial Bus Type-C Cable and Connector Specification, Release 1.0 August 2014, Page 21).

2.3.3 Initial DFP-to-UFP (host-to-device) and Power Relationships Detection

Unlike existing USB Type-A and Type-B receptacles and plugs, the mechanical characteristics of the USB Type-C receptacle and plug do not inherently establish the relationship of USB host and device ports. The CC pins on the receptacle also serve to establish an initial DFP-to-UFP and power relationships prior to the normal USB enumeration process.

For the purpose of defining how the CC pins are used to establish the initial DFP-to-UFP relationship, the following port behavior modes are defined.

1. Host-only – for this mode, the port exclusively behaves as a DFP
2. Device-only – for this mode, the port exclusively behaves as a UFP
3. Dual-role – for this mode, the port can behave either as a DFP or UFP

(E.g., <https://www.those.ch/designtechnik/wp-content/uploads/2014/08/USB-Type-C-Specification-Release-1.0.pdf>, Universal Serial Bus Type-C Cable and Connector Specification, Release 1.0 August 2014, Page 21).

Table 3-4 USB Type-C Receptacle Interface Pin Assignments

Pin	Signal Name	Description	Mating Sequence	Pin	Signal Name	Description	Mating Sequence
A1	GND	Ground return	First	B12	GND	Ground return	First
A2	SSTXp1	Positive half of first SuperSpeed TX differential pair	Second	B11	SSRXp1	Positive half of first SuperSpeed RX differential pair	Second
A3	SSTXn1	Negative half of first SuperSpeed TX differential pair	Second	B10	SSRXn1	Negative half of first SuperSpeed RX differential pair	Second
A4	VBUS	Bus Power	First	B9	VBUS	Bus Power	First
A5	CC1	Configuration Channel	Second	B8	SBU2	Sideband Use (SBU)	Second
A6	Dp1	Positive half of the USB 2.0 differential pair – Position 1	Second	B7	Dn2	Negative half of the USB 2.0 differential pair – Position 2	Second
A7	Dn1	Negative half of the USB 2.0 differential pair – Position 1	Second	B6	Dp2	Positive half of the USB 2.0 differential pair – Position 2	Second
A8	SBU1	Sideband Use (SBU)	Second	B5	CC2	Configuration Channel	Second
A9	VBUS	Bus Power	First	B4	VBUS	Bus Power	First
A10	SSRXn2	Negative half of second SuperSpeed RX differential pair	Second	B3	SSTXn2	Negative half of second SuperSpeed TX differential pair	Second
A11	SSRXp2	Positive half of second SuperSpeed RX differential pair	Second	B2	SSTXp2	Positive half of second SuperSpeed TX differential pair	Second
A12	GND	Ground return	First	B1	GND	Ground return	First

(E.g., <https://www.those.ch/designtechnik/wp-content/uploads/2014/08/USB-Type-C-Specification-Release-1.0.pdf>, Universal Serial Bus Type-C Cable and Connector Specification,

Release 1.0 August 2014, Page 49).

Figure 4-5 Pull-Up/Pull-Down CC Model

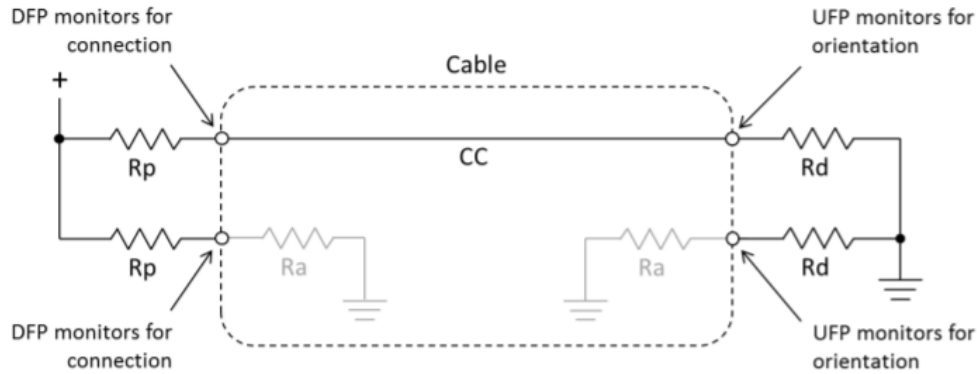

(E.g., <https://www.those.ch/designtechnik/wp-content/uploads/2014/08/USB-Type-C-Specification-Release-1.0.pdf>, Universal Serial Bus Type-C Cable and Connector Specification, Release 1.0 August 2014, Page 107).

Figure 4-6 Current Source/Pull-Down CC Model

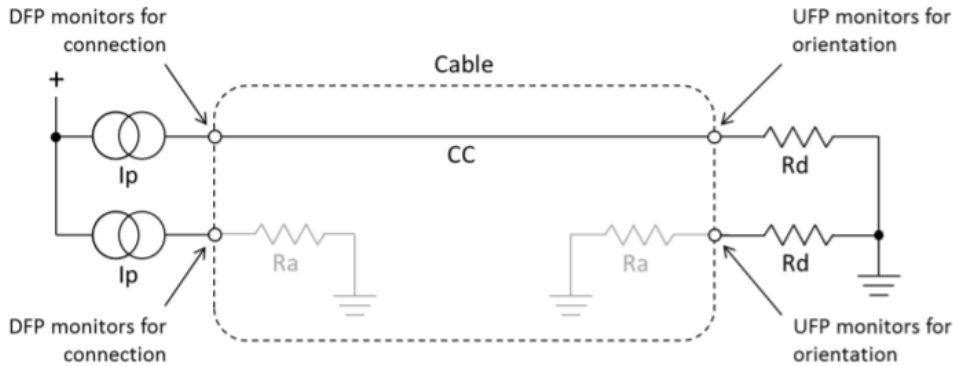

(E.g., <https://www.those.ch/designtechnik/wp-content/uploads/2014/08/USB-Type-C-Specification-Release-1.0.pdf>, Universal Serial Bus Type-C Cable and Connector Specification, Release 1.0 August 2014, Page 107).

Figure 4-3 Logical Model for Data Bus Routing across USB Type-C-based Ports

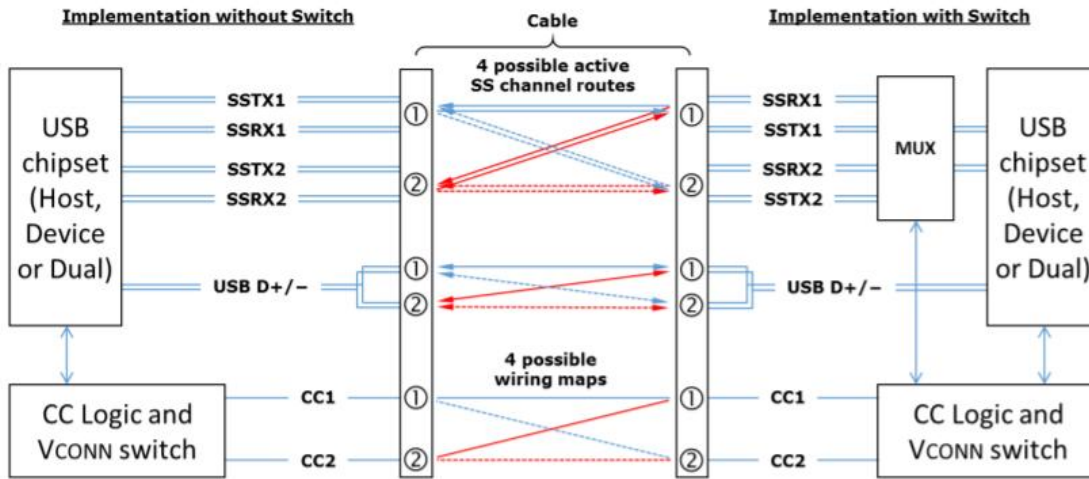

(E.g., <https://www.those.ch/designtechnik/wp-content/uploads/2014/08/USB-Type-C-Specification-Release-1.0.pdf>, Universal Serial Bus Type-C Cable and Connector Specification, Release 1.0 August 2014, Page 105).

4.5.1.1 USB Data Bus Interface and USB Type-C Plug Flip-ability

Since the USB Type-C plug can be inserted in either right-side-up or upside-down position, the hosts and devices that support USB data bus functionality must operate on the signal pins that are actually connected end-to-end. In the case of USB 2.0, this is done by shorting together the two D+ signal pins and the two D- signal pins in the DFP and UFP receptacles. In the case of USB SuperSpeed signals, it requires the functional equivalent of a switch in both the DFP and UFP to appropriately route the SuperSpeed TX and RX signal pairs to the connected path through the cable.

(E.g., <https://www.those.ch/designtechnik/wp-content/uploads/2014/08/USB-Type-C-Specification-Release-1.0.pdf>, Universal Serial Bus Type-C Cable and Connector Specification, Release 1.0 August 2014, Page 104).

2.4 Vbus

Vbus provides a path to deliver power between a host and a device, and between a charger and a host/device. A simplified high-current supply capability is defined for hosts and chargers that optionally support current levels beyond the [USB 2.0](#) and [USB 3.1](#) specifications. The [USB Power Delivery Specification](#) is supported.

Table 2-1 summarizes the power supply options available from the perspective of a device with the USB Type-C connector. Not all options will be available to the device from all host

(E.g., <https://www.those.ch/designtechnik/wp-content/uploads/2014/08/USB-Type-C-Specification-Release-1.0.pdf>, Universal Serial Bus Type-C Cable and Connector Specification, Release 1.0 August 2014, Page 104).

[Specification-Release-1.0.pdf](#), Universal Serial Bus Type-C Cable and Connector Specification, Release 1.0 August 2014, Page 22).

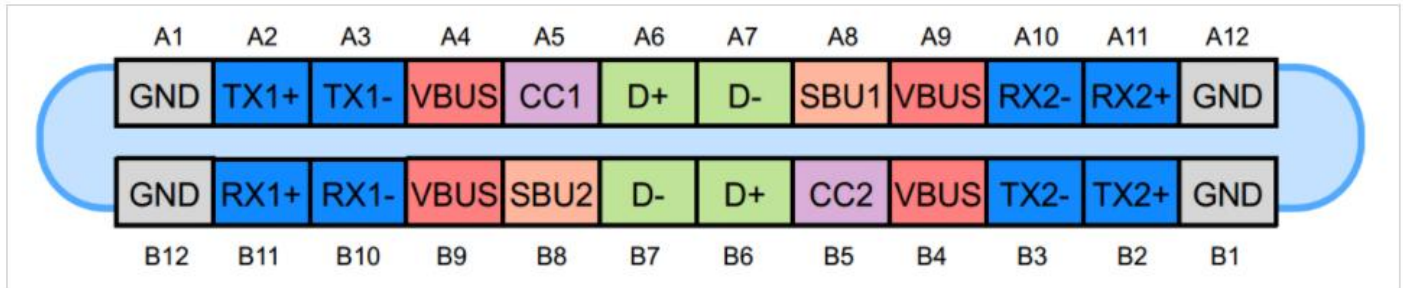

Figure 1. The USB Type-C receptacle. Image courtesy of Microchip.

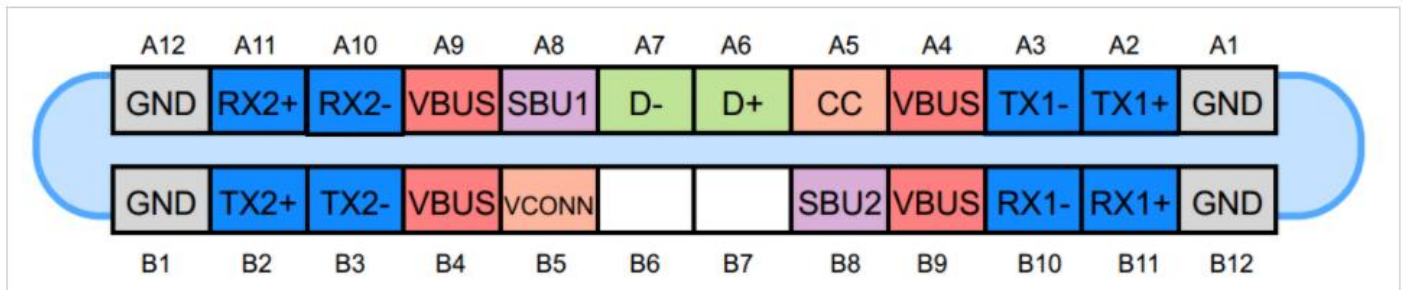

Figure 2. The USB Type-C plug. Image courtesy of Microchip.

(E.g., <https://www.allaboutcircuits.com/technical-articles/introduction-to-usb-type-c-which-pins-power-delivery-data-transfer/>).

8.3.2.3 Power Negotiation

Figure 8-5 illustrates an example of a successful Message flow during Power Negotiation. The negotiation goes through 5 distinct phases:

- The Source sends out its power capabilities in a **Source Capabilities** Message.
- The Sink evaluates these capabilities and in the request phase selects one power level by sending a **Request** Message.
- The Source evaluates the request and accepts the request with an **Accept** Message.
- The Source transitions to the new power level and then informs the Sink by sending a **PS_RDY** Message.
- The Sink starts using the new power level.

(E.g., <https://usb.org/sites/default/files/USB%20Power%20Delivery%2020210706.zip>, Universal Serial Bus Power Delivery Specification, Revision 2.0 Release January 2017, Page 297)

Figure 8-5 Successful Power Negotiation

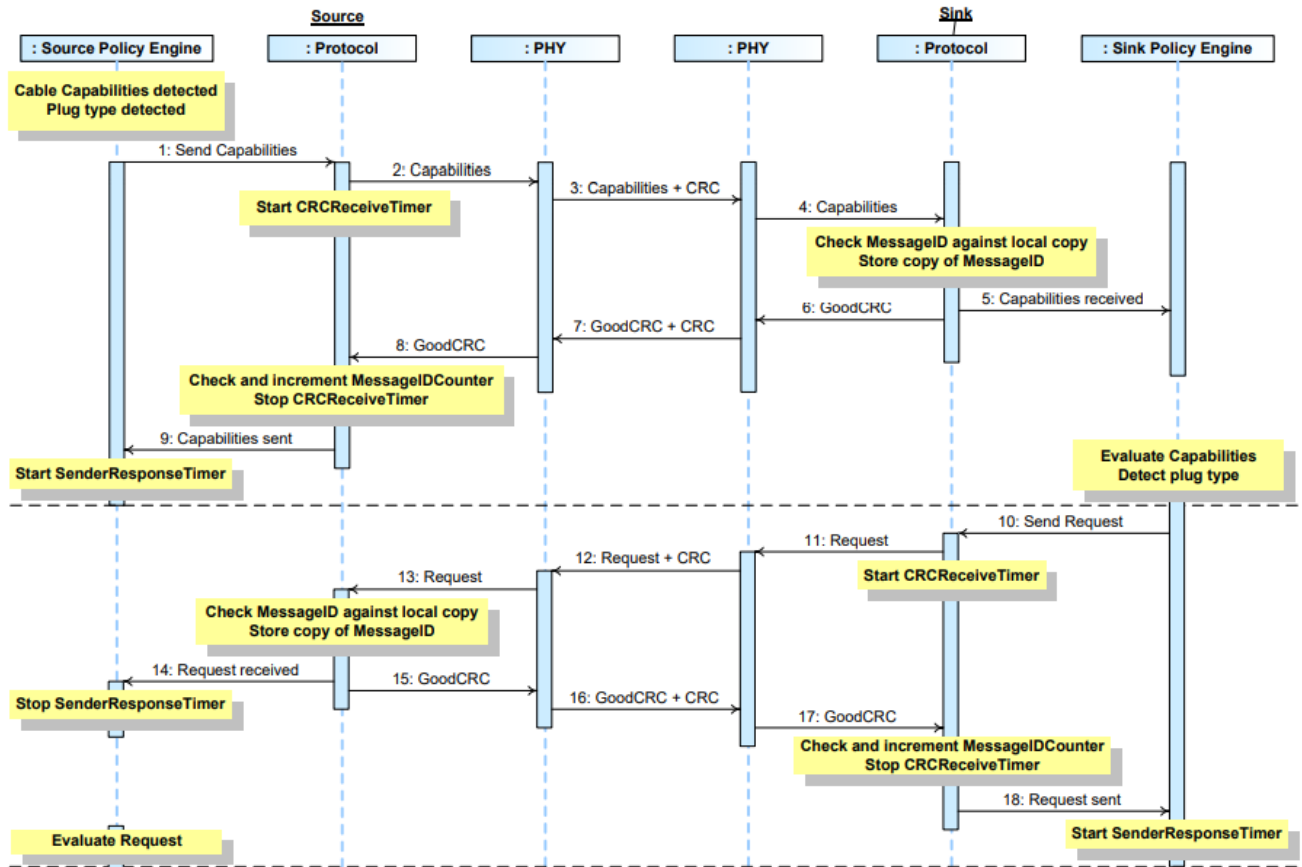

(E.g., <https://usb.org/sites/default/files/USB%20Power%20Delivery%2020210706.zip>, Universal Serial Bus Power Delivery Specification, Revision 2.0 Release January 2017, Page 298)

To establish the proper routing of the active USB data bus from DFP to UFP, the standard USB Type-C cable is wired such that a single CC wire is position aligned with the first USB SuperSpeed signal pairs (SSTXp1/SSTXn1 and SSRXp1/SSRXn1) – in this way, the CC wire and USB SuperSpeed data bus wires that are used for signaling within the cable track with regard to the orientation and twist of the cable. By being able to detect which of the CC pins (CC1 or CC2) at the receptacle is terminated by the UFP, the DFP is able to determine which SuperSpeed USB signals are to be used for the connection and the DFP can use this to control the functional switch for routing the SuperSpeed USB signal pairs. Similarly in the UFP, detecting which of the CC pins at the receptacle is terminated by the DFP allows the UFP to control the functional switch that routes its SuperSpeed USB signal pairs.

(E.g., <https://www.those.ch/designtechnik/wp-content/uploads/2014/08/USB-Type-C-Specification-Release-1.0.pdf>, Universal Serial Bus Type-C Cable and Connector Specification, Release 1.0 August 2014, Page 105).

29. Defendant provided a product or system, such as the ‘187 Accused PD Chargers, that include a connector disposed on a cable end, the connector having four conductors for detachably mating with a power input opening of the portable electronic device, the first and second conductors transferring the DC power and its ground reference to the portable electronic device, the third conductor transferring the first signal from the portable electronic device to the data circuitry, and the fourth conductor transferring the second signal from the data circuitry to the portable electronic device. This element is met literally, or in the alternative, under the doctrine of equivalents. For example, the adapter connects to the portable electronic device through a USB cable. The USB cable has a connector of the type including but not limited to USB-C at one end to detachably mate with the charging port of a portable electronic device. The connector comprises VBUS (“first conductor”), GND (“second conductor”), CC1/CC2 (“third conductor”), and RX (“fourth conductor”) pins. Further, the VBUS (Voltage line of the USB interface) pin is the voltage line that provides DC power to the portable electronic device and the GND pin provides a ground reference to the portable electronic device. Further, the CC1/CC2 pin provides the CC signal (“first signal”) from the portable electronic device to the data circuitry of the adapter, and RX pin provides the RX signal (“second signal”) from the data circuitry of the adapter to the portable electronic device.

The USB Type-C receptacle, plug and cable designs are intended to support future USB functional extensions. As such, consideration was given to frequency scaling performance, pin-out arrangement and the configuration mechanisms when developing this solution. The definition of future USB functional extensions is not in the scope of this specification but rather will be provided in future releases of the base USB Specification, i.e., beyond the existing [USB 3.1 Specification](#).

Figure 2-1 illustrates the comprehensive functional signal plan for the USB Type-C receptacle, not all signals shown are required in all platforms or devices. As shown, the receptacle signal list functionally delivers both [USB 2.0](#) (D+ and D-) and [USB 3.1](#) (TX and RX pairs) data buses, USB power (VBUS) and ground (GND), [Configuration Channel](#) signals (CC1 and CC2), and two Sideband Use (SBU) signal pins. Multiple sets of USB data bus signal locations in this layout facilitate being able to functionally map the USB signals independent of plug orientation in the receptacle. For reference, the signal pins are labeled.

(E.g., <https://www.those.ch/designtechnik/wp-content/uploads/2014/08/USB-Type-C-Specification-Release-1.0.pdf>, Universal Serial Bus Type-C Cable and Connector Specification, Release 1.0 August 2014, Page 18).

Figure 2-1 USB Type-C Receptacle Interface (Front View)

A1	A2	A3	A4	A5	A6	A7	A8	A9	A10	A11	A12
GND	TX1+	TX1-	VBUS	CC1	D+	D-	SBU1	VBUS	RX2-	RX2+	GND
GND	RX1+	RX1-	VBUS	SBU2	D-	D+	CC2	VBUS	TX2-	TX2+	GND
B12	B11	B10	B9	B8	B7	B6	B5	B4	B3	B2	B1

(E.g., <https://www.those.ch/designtechnik/wp-content/uploads/2014/08/USB-Type-C-Specification-Release-1.0.pdf>, Universal Serial Bus Type-C Cable and Connector Specification, Release 1.0 August 2014, Page 18).

To establish the proper routing of the active USB data bus from DFP to UFP, the standard USB Type-C cable is wired such that a single CC wire is position aligned with the first USB SuperSpeed signal pairs (SSTXp1/SSTXn1 and SSRXp1/SSRXn1) – in this way, the CC wire and USB SuperSpeed data bus wires that are used for signaling within the cable track with regard to the orientation and twist of the cable. By being able to detect which of the CC pins (CC1 or CC2) at the receptacle is terminated by the UFP, the DFP is able to determine which SuperSpeed USB signals are to be used for the connection and the DFP can use this to control the functional switch for routing the SuperSpeed USB signal pairs. Similarly in the UFP, detecting which of the CC pins at the receptacle is terminated by the DFP allows the UFP to control the functional switch that routes its SuperSpeed USB signal pairs.

(E.g., <https://www.those.ch/designtechnik/wp-content/uploads/2014/08/USB-Type-C-Specification-Release-1.0.pdf>, Universal Serial Bus Type-C Cable and Connector Specification, Release 1.0 August 2014, Page 105).

5.2 Physical Layer Functions

The USB PD Physical Layer consists of a pair of transmitters and receivers that communicate across a single signal wire (V_{BUS} or CC). All communication is half duplex. The PHY Layer practices collision avoidance to minimize communication errors on the channel.

(E.g., <https://usb.org/sites/default/files/USB%20Power%20Delivery%2020210706.zip>, Universal Serial Bus Power Delivery Specification, Revision 2.0 Release January 2017, Page 104).

2.3 Configuration Process

The USB Type-C receptacle, plug and cable solution incorporates a configuration process to detect a downstream facing port to upstream facing port (DFP-to-UFP) connection for VBUS management and host-to-device connected relationship determination.

The configuration process is used for the following:

- DFP-to-UFP attach/detach detection
- Plug orientation/cable twist detection
- Initial DFP-to-UFP (host-to-device) and power relationships detection
- USB Type-C VBUS current detection and usage
- [USB PD](#) communication
- Discovery and configuration of functional extensions

(E.g., <https://www.those.ch/designtechnik/wp-content/uploads/2014/08/USB-Type-C-Specification-Release-1.0.pdf>, Universal Serial Bus Type-C Cable and Connector Specification, Release 1.0 August 2014, Page 20).

2.3.1 DFP-to-UFP Attach/Detach Detection

Initially, DFP-to-UFP attach is detected by a host or hub port (DFP) when one of the CC pins at its USB Type-C receptacle senses a specified resistance to GND. Subsequently, DFP-to-UFP detach is detected when the CC pin that was terminated at its USB Type-C receptacle is no longer terminated to GND.

Power is not applied to the USB Type-C host or hub receptacle (VBUS or VCONN) until the DFP detects the presence of an attached device (UFP) port. When a DFP-to-UFP attach is detected, the DFP is expected to enable power to the receptacle and proceed to normal USB operation with the attached device. When a DFP-to-UFP detach is detected, the port sourcing VBUS removes power.

(E.g., <https://www.those.ch/designtechnik/wp-content/uploads/2014/08/USB-Type-C-Specification-Release-1.0.pdf>, Universal Serial Bus Type-C Cable and Connector Specification, Release 1.0 August 2014, Page 21).

2.3.2 Plug Orientation/Cable Twist Detection

The USB Type-C plug can be inserted into a receptacle in either one of two orientations, therefore the CC pins enable a method for detecting plug orientation in order to determine which SuperSpeed USB data signal pairs are functionally connected through the cable. This allows for signal routing, if needed, within a DFP or UFP to be established for a successful connection.

(E.g., <https://www.those.ch/designtechnik/wp-content/uploads/2014/08/USB-Type-C-Specification-Release-1.0.pdf>, Universal Serial Bus Type-C Cable and Connector Specification, Release 1.0 August 2014, Page 21).

[Specification-Release-1.0.pdf](#), Universal Serial Bus Type-C Cable and Connector Specification, Release 1.0 August 2014, Page 21).

Figure 4-3 Logical Model for Data Bus Routing across USB Type-C-based Ports

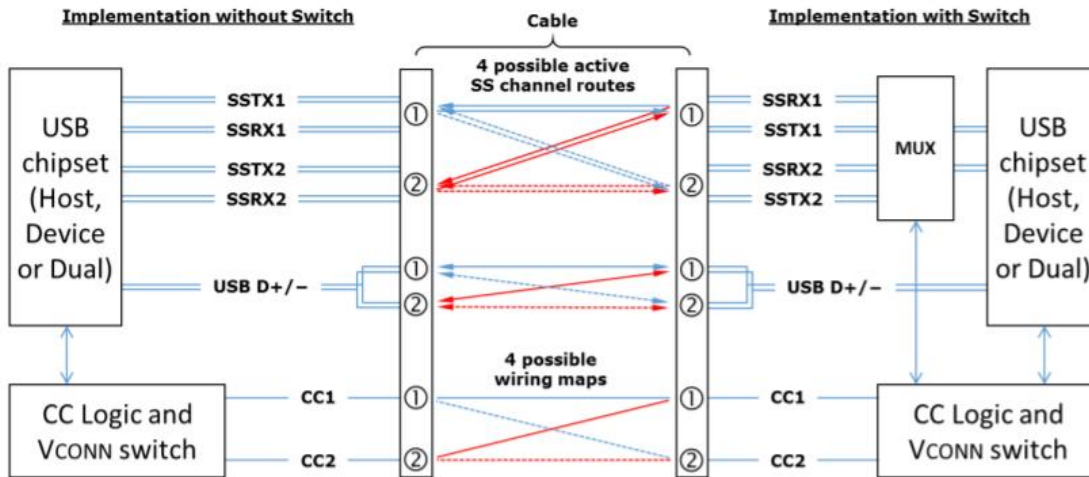

(E.g., <https://www.those.ch/designtechnik/wp-content/uploads/2014/08/USB-Type-C-Specification-Release-1.0.pdf>, Universal Serial Bus Type-C Cable and Connector Specification, Release 1.0 August 2014, Page 105).

4.5.1.1 USB Data Bus Interface and USB Type-C Plug Flip-ability

Since the USB Type-C plug can be inserted in either right-side-up or upside-down position, the hosts and devices that support USB data bus functionality must operate on the signal pins that are actually connected end-to-end. In the case of USB 2.0, this is done by shorting together the two D+ signal pins and the two D- signal pins in the DFP and UFP receptacles. In the case of USB SuperSpeed signals, it requires the functional equivalent of a switch in both the DFP and UFP to appropriately route the SuperSpeed TX and RX signal pairs to the connected path through the cable.

(E.g., <https://www.those.ch/designtechnik/wp-content/uploads/2014/08/USB-Type-C-Specification-Release-1.0.pdf>, Universal Serial Bus Type-C Cable and Connector Specification, Release 1.0 August 2014, Page 104).

2.4 VBUS

VBUS provides a path to deliver power between a host and a device, and between a charger and a host/device. A simplified high-current supply capability is defined for hosts and chargers that optionally support current levels beyond the [USB 2.0](#) and [USB 3.1](#) specifications. The [USB Power Delivery Specification](#) is supported.

Table 2-1 summarizes the power supply options available from the perspective of a device with the USB Type-C connector. Not all options will be available to the device from all host

(E.g., <https://www.those.ch/designtechnik/wp-content/uploads/2014/08/USB-Type-C-Specification-Release-1.0.pdf>, Universal Serial Bus Type-C Cable and Connector Specification, Release 1.0 August 2014, Page 22).

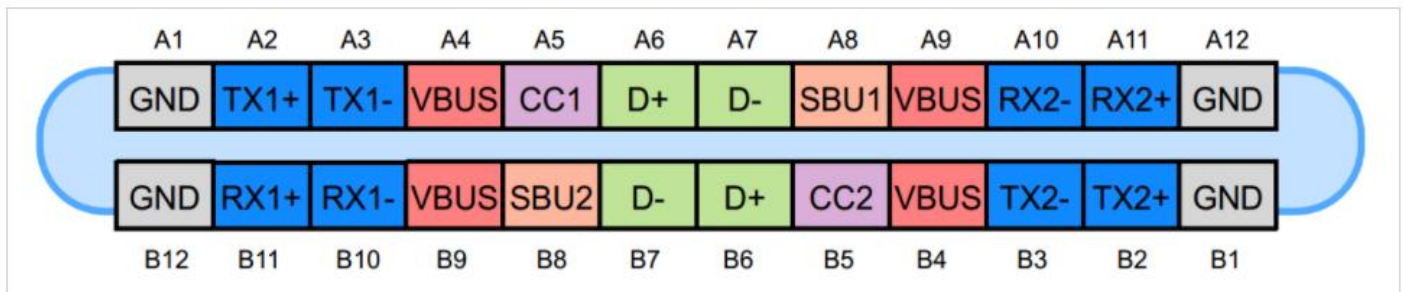

Figure 1. The USB Type-C receptacle. Image courtesy of *Microchip*.

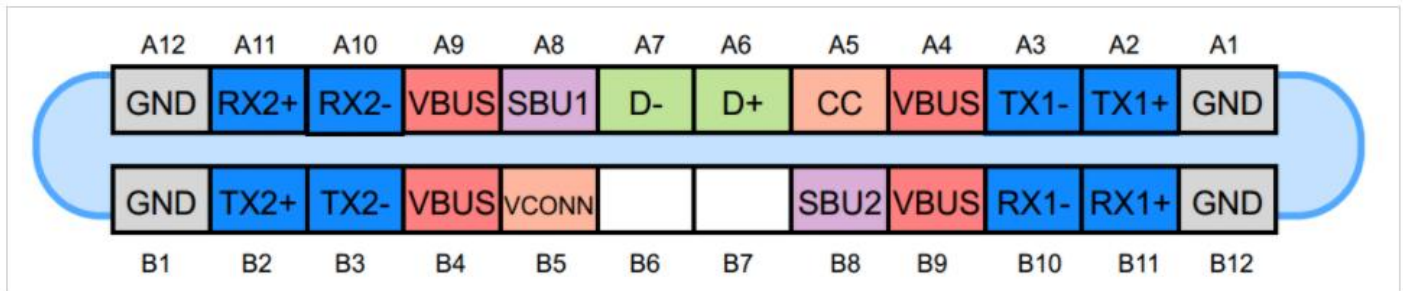

Figure 2. The USB Type-C plug. Image courtesy of *Microchip*.

(E.g., <https://www.allaboutcircuits.com/technical-articles/introduction-to-usb-type-c-which-pins-power-delivery-data-transfer/>).

30. Defendant provided a product or system with the data circuitry, such as in ‘187 Accused PD Charger, that in response to the first signal, provides the second signal to the portal electronic device, the second signal being an analog signal having a parameter level to indicate to

the portable electronic device the potential power output level of the power supply system. This element is met literally, or in the alternative, under the doctrine of equivalents. For example, in response to the CC1/CC2 signal (“first signal”), the data circuitry of the adapter provides RX signal (“second signal”) to the portable electronic device to configure the device and transfer data. The RX signal is an analog signal such that the signals are able to assume a plurality of voltages.

8.3.2.3 Power Negotiation

Figure 8-5 illustrates an example of a successful Message flow during Power Negotiation. The negotiation goes through 5 distinct phases:

- The Source sends out its power capabilities in a *Source_Capabilities* Message.
- The Sink evaluates these capabilities and in the request phase selects one power level by sending a *Request* Message.
- The Source evaluates the request and accepts the request with an *Accept* Message.
- The Source transitions to the new power level and then informs the Sink by sending a *PS_RDY* Message.
- The Sink starts using the new power level.

(E.g., <https://usb.org/sites/default/files/USB%20Power%20Delivery%2020210706.zip>, Universal Serial Bus Power Delivery Specification, Revision 2.0 Release January 2017, Page 297).

Figure 8-5 Successful Power Negotiation

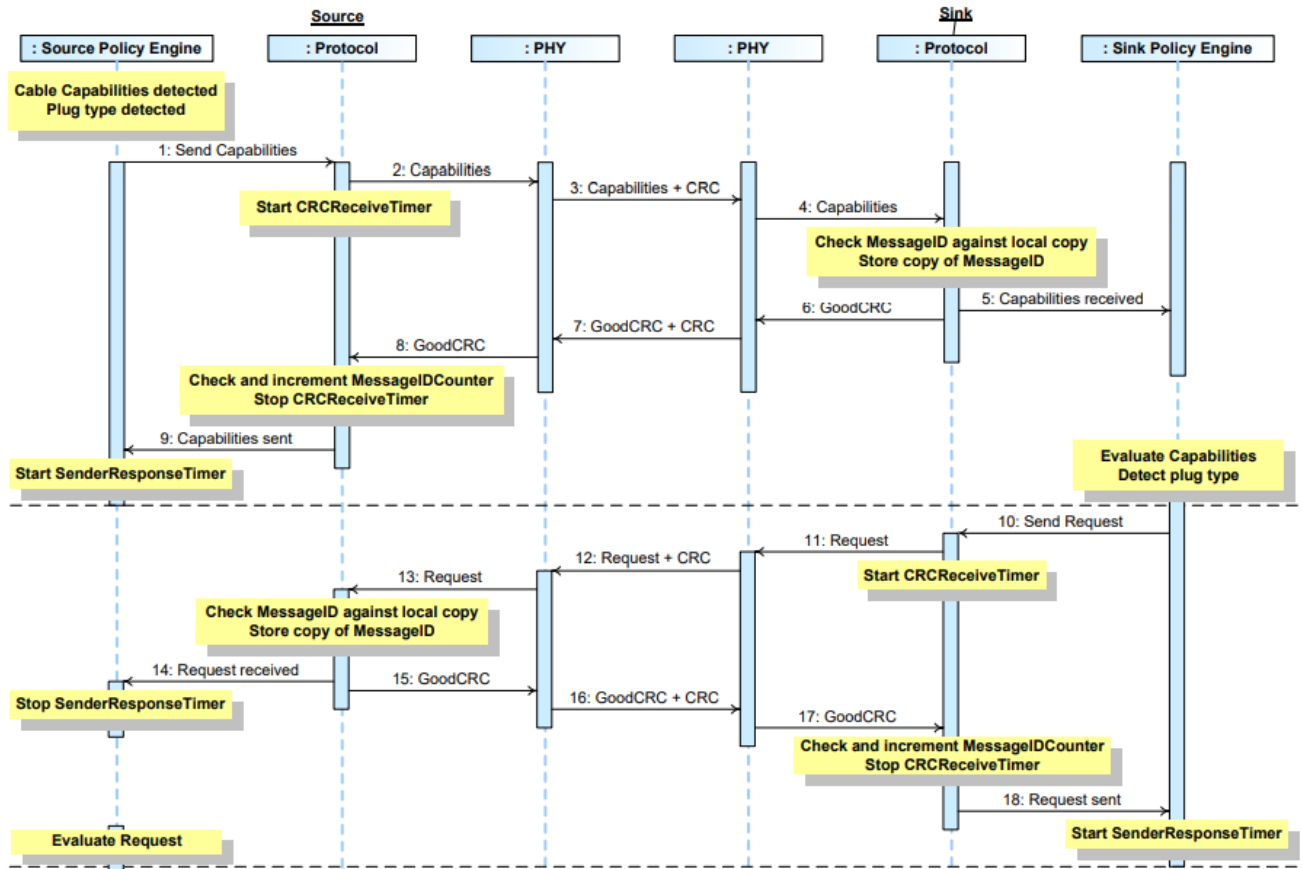

(E.g., <https://usb.org/sites/default/files/USB%20Power%20Delivery%2020210706.zip>, Universal Serial Bus Power Delivery Specification, Revision 2.0 Release January 2017, Page 298).

To establish the proper routing of the active USB data bus from DFP to UFP, the standard USB Type-C cable is wired such that a single CC wire is position aligned with the first USB SuperSpeed signal pairs (SSTXp1/SSTXn1 and SSRXp1/SSRXn1) – in this way, the CC wire and USB SuperSpeed data bus wires that are used for signaling within the cable track with regard to the orientation and twist of the cable. By being able to detect which of the CC pins (CC1 or CC2) at the receptacle is terminated by the UFP, the DFP is able to determine which SuperSpeed USB signals are to be used for the connection and the DFP can use this to control the functional switch for routing the SuperSpeed USB signal pairs. Similarly in the UFP, detecting which of the CC pins at the receptacle is terminated by the DFP allows the UFP to control the functional switch that routes its SuperSpeed USB signal pairs.

(E.g., <https://www.those.ch/designtechnik/wp-content/uploads/2014/08/USB-Type-C-Specification-Release-1.0.pdf>, Universal Serial Bus Type-C Cable and Connector Specification, Release 1.0 August 2014, Page 105).

2.3 Configuration Process

The USB Type-C receptacle, plug and cable solution incorporates a configuration process to detect a downstream facing port to upstream facing port (DFP-to-UFP) connection for VBUS management and host-to-device connected relationship determination.

The configuration process is used for the following:

- DFP-to-UFP attach/detach detection
- Plug orientation/cable twist detection
- Initial DFP-to-UFP (host-to-device) and power relationships detection
- USB Type-C VBUS current detection and usage
- [USB PD](#) communication
- Discovery and configuration of functional extensions

(E.g., <https://www.those.ch/designtechnik/wp-content/uploads/2014/08/USB-Type-C-Specification-Release-1.0.pdf>, Universal Serial Bus Type-C Cable and Connector Specification, Release 1.0 August 2014, Page 20).

2.3.1 DFP-to-UFP Attach/Detach Detection

Initially, DFP-to-UFP attach is detected by a host or hub port (DFP) when one of the CC pins at its USB Type-C receptacle senses a specified resistance to GND. Subsequently, DFP-to-UFP detach is detected when the CC pin that was terminated at its USB Type-C receptacle is no longer terminated to GND.

Power is not applied to the USB Type-C host or hub receptacle (VBUS or VCONN) until the DFP detects the presence of an attached device (UFP) port. When a DFP-to-UFP attach is detected, the DFP is expected to enable power to the receptacle and proceed to normal USB operation with the attached device. When a DFP-to-UFP detach is detected, the port sourcing VBUS removes power.

(E.g., <https://www.those.ch/designtechnik/wp-content/uploads/2014/08/USB-Type-C-Specification-Release-1.0.pdf>, Universal Serial Bus Type-C Cable and Connector Specification, Release 1.0 August 2014, Page 21).

2.3.2 Plug Orientation/Cable Twist Detection

The USB Type-C plug can be inserted into a receptacle in either one of two orientations, therefore the CC pins enable a method for detecting plug orientation in order to determine which SuperSpeed USB data signal pairs are functionally connected through the cable. This allows for signal routing, if needed, within a DFP or UFP to be established for a successful connection.

(E.g., <https://www.those.ch/designtechnik/wp-content/uploads/2014/08/USB-Type-C-Specification-Release-1.0.pdf>, Universal Serial Bus Type-C Cable and Connector Specification, Release 1.0 August 2014, Page 21).

[Specification-Release-1.0.pdf](#), Universal Serial Bus Type-C Cable and Connector Specification, Release 1.0 August 2014, Page 21).

Figure 4-3 Logical Model for Data Bus Routing across USB Type-C-based Ports

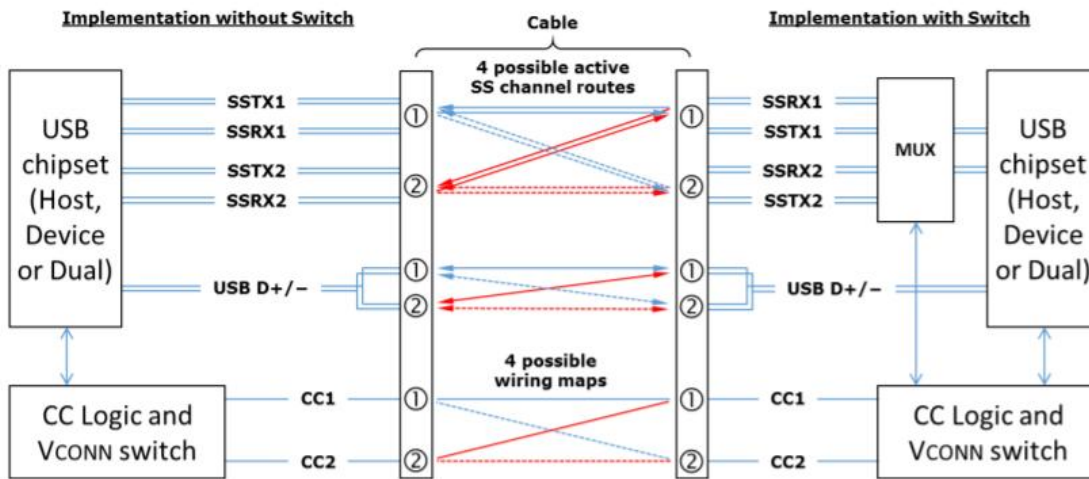

(E.g., <https://www.those.ch/designtechnik/wp-content/uploads/2014/08/USB-Type-C-Specification-Release-1.0.pdf>, Universal Serial Bus Type-C Cable and Connector Specification, Release 1.0 August 2014, Page 105).

4.5.1.1 USB Data Bus Interface and USB Type-C Plug Flip-ability

Since the USB Type-C plug can be inserted in either right-side-up or upside-down position, the hosts and devices that support USB data bus functionality must operate on the signal pins that are actually connected end-to-end. In the case of USB 2.0, this is done by shorting together the two D+ signal pins and the two D- signal pins in the DFP and UFP receptacles. In the case of USB SuperSpeed signals, it requires the functional equivalent of a switch in both the DFP and UFP to appropriately route the SuperSpeed TX and RX signal pairs to the connected path through the cable.

(E.g., <https://www.those.ch/designtechnik/wp-content/uploads/2014/08/USB-Type-C-Specification-Release-1.0.pdf>, Universal Serial Bus Type-C Cable and Connector Specification, Release 1.0 August 2014, Page 104).

2.3.3 Initial DFP-to-UFP (host-to-device) and Power Relationships Detection

Unlike existing USB Type-A and Type-B receptacles and plugs, the mechanical characteristics of the USB Type-C receptacle and plug do not inherently establish the relationship of USB host and device ports. The CC pins on the receptacle also serve to establish an initial DFP-to-UFP and power relationships prior to the normal USB enumeration process.

For the purpose of defining how the CC pins are used to establish the initial DFP-to-UFP relationship, the following port behavior modes are defined.

1. Host-only – for this mode, the port exclusively behaves as a DFP
2. Device-only – for this mode, the port exclusively behaves as a UFP
3. Dual-role – for this mode, the port can behave either as a DFP or UFP

(E.g., <https://www.those.ch/designtechnik/wp-content/uploads/2014/08/USB-Type-C-Specification-Release-1.0.pdf>, Universal Serial Bus Type-C Cable and Connector Specification, Release 1.0 August 2014, Page 21).

Table 3-4 USB Type-C Receptacle Interface Pin Assignments

Pin	Signal Name	Description	Mating Sequence	Pin	Signal Name	Description	Mating Sequence
A1	GND	Ground return	First	B12	GND	Ground return	First
A2	SSTXp1	Positive half of first SuperSpeed TX differential pair	Second	B11	SSRXp1	Positive half of first SuperSpeed RX differential pair	Second
A3	SSTXn1	Negative half of first SuperSpeed TX differential pair	Second	B10	SSRXn1	Negative half of first SuperSpeed RX differential pair	Second
A4	VBUS	Bus Power	First	B9	VBUS	Bus Power	First
A5	CC1	Configuration Channel	Second	B8	SBU2	Sideband Use (SBU)	Second
A6	Dp1	Positive half of the USB 2.0 differential pair – Position 1	Second	B7	Dn2	Negative half of the USB 2.0 differential pair – Position 2	Second
A7	Dn1	Negative half of the USB 2.0 differential pair – Position 1	Second	B6	Dp2	Positive half of the USB 2.0 differential pair – Position 2	Second
A8	SBU1	Sideband Use (SBU)	Second	B5	CC2	Configuration Channel	Second
A9	VBUS	Bus Power	First	B4	VBUS	Bus Power	First
A10	SSRXn2	Negative half of second SuperSpeed RX differential pair	Second	B3	SSTXn2	Negative half of second SuperSpeed TX differential pair	Second
A11	SSRXp2	Positive half of second SuperSpeed RX differential pair	Second	B2	SSTXp2	Positive half of second SuperSpeed TX differential pair	Second
A12	GND	Ground return	First	B1	GND	Ground return	First

(E.g., <https://www.those.ch/designtechnik/wp-content/uploads/2014/08/USB-Type-C-Specification-Release-1.0.pdf>, Universal Serial Bus Type-C Cable and Connector Specification,

Release 1.0 August 2014, Page 49).

Figure 4-5 Pull-Up/Pull-Down CC Model

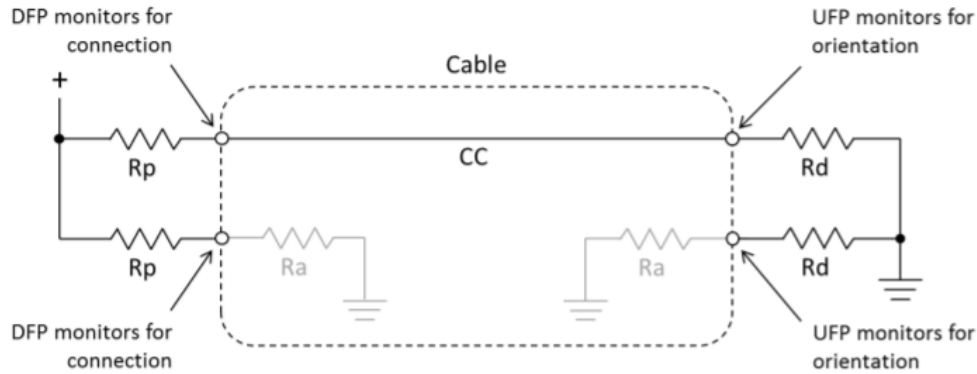

(E.g., <https://www.those.ch/designtechnik/wp-content/uploads/2014/08/USB-Type-C-Specification-Release-1.0.pdf>, Universal Serial Bus Type-C Cable and Connector Specification, Release 1.0 August 2014, Page 107).

Figure 4-6 Current Source/Pull-Down CC Model

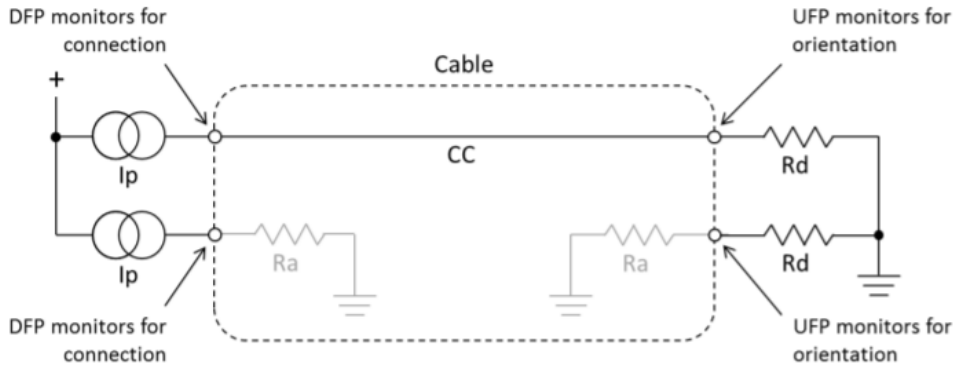

(E.g., <https://www.those.ch/designtechnik/wp-content/uploads/2014/08/USB-Type-C-Specification-Release-1.0.pdf>, Universal Serial Bus Type-C Cable and Connector Specification, Release 1.0 August 2014, Page 107).

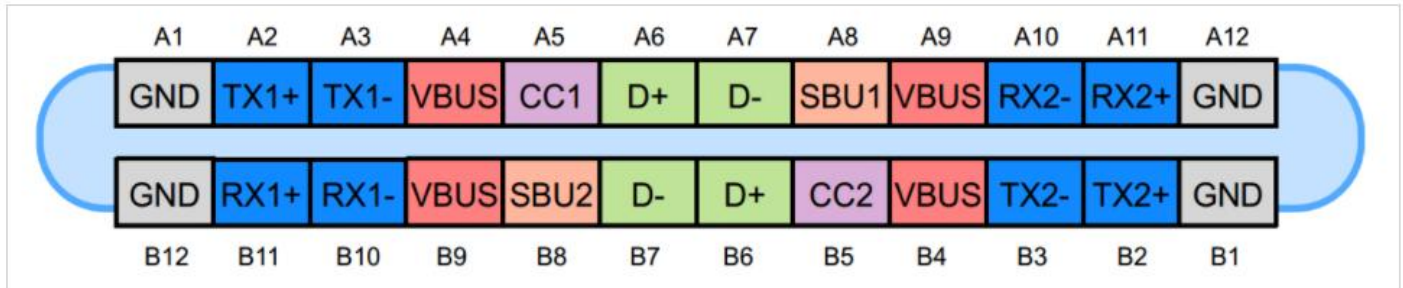

Figure 1. The USB Type-C receptacle. Image courtesy of Microchip.

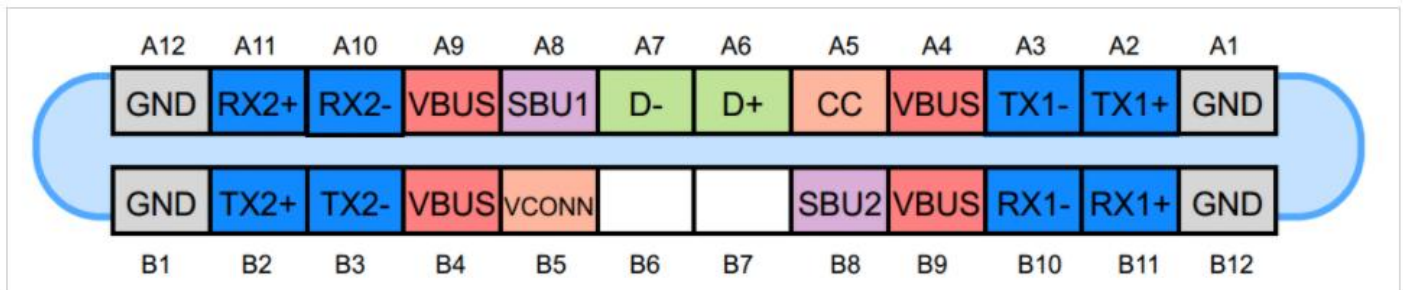

Figure 2. The USB Type-C plug. Image courtesy of Microchip.

(E.g., <https://www.allaboutcircuits.com/technical-articles/introduction-to-usb-type-c-which-pins-power-delivery-data-transfer/>).

31. Defendant provided a product or system, including the ‘187 Accused PD Charger in which the power circuitry of the power supply system converts power from an external power source to DC power. For example, to charge a portable electronic device, a USB cable is connected to the external USB power supply. Further, the other end of a USB cable is connected to the charging port of the portable electronic device and the power supply is plugged into a standard wall socket. Therefore, the external USB power supply system comprises power circuitry to provide DC power to the portable electronic device.

D. Indirect Infringement

32. Upon information and belief, Defendant was indirectly infringing by way of inducing infringement and contributing to the infringement of the asserted claims of the ‘187

patent in the State of Texas, in this District, and elsewhere in the United States, by providing the '187 Accused Chargers for use as described above by Defendant's customers. Defendant advertised, offered for sale, and/or sold the '187 Accused Chargers to its customers for use in a manner that Defendant knew infringed at least one claim of the '187 patent. For example, Defendant advertised and sold the '187 Accused Chargers. Defendant was a direct and indirect infringer, and its customers using the '187 Accused Chargers were direct infringers. Defendant had actual knowledge of the '187 patent at least as early as when they received letters from Plaintiff sent on August 1, 2023, and April 13, 2024, asserting that the '187 Accused Chargers infringed claims of the '187 patent and they were provided a claim chart that provided evidence of the infringement. Defendant has known of its infringement since at least that date as a result of the accusations of infringement in the notice letters. Defendant has therefore also known that the use of the '187 Accused Chargers by its customers infringed at least one claim of the '187 patent since at least the date they received the letters.

33. On information and belief, since Defendant became aware of the '187 patent and of the infringement through advertising and offering for sale the '187 Accused Chargers for use by its customers, Defendant was committing the act of inducing infringement by specifically intending to induce infringement by providing the '187 Accused Chargers to its customers and by aiding and abetting its use in a manner known to infringe by Defendant. Since Defendant became aware of the infringing use of the '187 Accused Chargers, Defendant knew that the use of the '187 Accused Chargers by its customers as a charger with a portable electronic device (including a rechargeable battery) constituted direct patent infringement. Despite this knowledge, Defendant continued and continues to encourage and induce its customers to use the '187 Accused Chargers to infringe as described above and provided instructions for using the '187 Accused Chargers to

infringe, including through advertisements. Defendant therefore knowingly induced infringement and specifically intended to encourage and induce the infringement of the '187 patent by its customers.

34. On information and belief, since Defendant became aware of the acts of infringement at least as of the date of receipt of the notice letters on August 1, 2023, and April 13, 2024, Defendant was committing the act of contributory infringement by intending to provide the '187 Accused Chargers to its customers knowing that such devices are a material part of the claimed invention, knowing that its use was made and adapted for infringement of the '187 patent as described above, and further knowing that the accused aspect of the '187 Accused Chargers described above is not a staple article or commodity of commerce suitable for substantially noninfringing use. As described above, Defendant was aware that all material claim limitations are satisfied by the use and implementation of the '187 Accused Chargers by Defendant's customers in the manner described above yet continued to provide the '187 Accused Chargers to its customers knowing that it is a material part of the claimed invention. As described above, since learning of the infringement, Defendant knew that the use and implementation of the '187 Accused Chargers by its customers was made and adapted for infringement of the '187 patent. A new act of direct infringement occurred each time a customer implemented and/or used the '187 Accused Chargers in the manner described above. After Defendant became aware that the use of the '187 Accused Chargers infringed at least one claim of the '187 patent, Defendant knew that each such new use was made and adapted for infringement of at least one claim of the '187 patent and Defendant continued to advertise and provide the '187 Accused Chargers for such infringing activities. Furthermore, as described more fully above, the '187 Accused Chargers have

functionality designed for use in a system in the manner described above and is therefore not a staple article or commodity of commerce suitable for substantially noninfringing use.

35. Upon information and belief, Defendant was willfully infringing the asserted claims of the '187 patent in Texas, in this District, and elsewhere in the United States. As explained above, Defendant was informed of its infringement of the '187 patent by way of the August 1, 2023, and April 13, 2024, letters sent to Defendant, including claim charts demonstrating Defendant's infringement. As a result of the letters, Defendant should have known that its actions constituted an unjustifiably high risk of infringement. Despite the letters and knowledge that the risk of infringement was either known or so obvious that it should have been known, Defendant continued its infringing actions.

36. Plaintiff has been damaged as a result of Defendant's infringing conduct. Defendant is thus liable to Plaintiff for damages in an amount that adequately compensates Plaintiff for Defendant's infringement of the '187 patent, *i.e.*, in an amount that by law cannot be less than a reasonable royalty for the use of the patented technology, together with interest and costs as fixed by this Court under 35 U.S.C. § 284.

V. COUNT II
(PATENT INFRINGEMENT OF UNITED STATES PATENT NO. 10,855,087)

37. Upon information and belief, Defendant directly infringed claims 1, 5-7, 11, and 15-17 of the '087 patent (in Texas, and elsewhere in the United States), by making, using, selling, offering for sale and/or importing a power supply system comprising power circuitry configured to provide direct current power such products including, but not limited to, the following: AT&T Multi Port 72W Power Delivery Power Hub (USB-C + USB-A); AT&T Dual Port 32W Power Delivery Bullet Car Charger (USB-C + USB-A); AT&T Dual Port 40W Power Delivery Bullet Car Charger (USB-C + USB-C); AT&T Dual Port 32W Power Delivery Wall Block (USB-C +

USB-A); AT&T Captive Cable Power Delivery Car Charger 40W with USB-C Port (USB-C); AT&T 10K Power Delivery Portable Battery with USB-C In/Out + USB-A Out; and AT&T Single Port 30W Power Delivery Wall Block USB-C (“’087 Accused Chargers”).

38. Claim 1 of the ’087 patent states:

A power supply system comprising:

power circuitry configured to provide direct current power; and

data circuitry configured to receive a first signal that originates from a portable electronic device and to provide a second signal to be sent to the portable electronic device, the data circuitry and the power circuitry configured to be coupled via a connector to the portable electronic device, the connector comprising a first conductor, a second conductor, a third conductor, and a fourth conductor, the connector configured to be detachably mated with a power input interface of the portable electronic device to:

transfer, via the first conductor, the direct current power to the portable electronic device,

transfer, via the second conductor, a ground reference to the portable electronic device,

transfer, via the third conductor, the first signal from the portable electronic device to the data circuitry, and

transfer, via the fourth conductor, the second signal from the data circuitry to the portable electronic device,

wherein the data circuitry is further configured, in coordination with the first signal, to provide the second signal having a parament level that is usable by the portable electronic device in connection with control of charging a rechargeable battery of the portable electronic device based on the direct current power provided by the power circuitry.

(Ex. B at 10:63-11:24).

A. Infringement for Compliance with Power Delivery Standard

39. Upon information and belief, Defendant directly infringed claims 1, 5-7, 11, and 15-17 of the ’087 patent (in Texas, and elsewhere in the United States), by making, using, selling, offering for sale and/or importing a power supply system comprising power circuitry configured to provide direct current power such products including, but not limited to, the following: AT&T

Multi Port 72W Power Delivery Power Hub (USB-C + USB-A); AT&T Dual Port 32W Power Delivery Bullet Car Charger (USB-C + USB-A); AT&T Dual Port 40W Power Delivery Bullet Car Charger (USB-C + USB-C); AT&T Dual Port 32W Power Delivery Wall Block (USB-C + USB-A); AT&T Captive Cable Power Delivery Car Charger 40W with USB-C Port (USB-C); AT&T 10K Power Delivery Portable Battery with USB-C In/Out + USB-A Out; and AT&T Single Port 30W Power Delivery Wall Block USB-C which comply with Universal Serial Bus Power Delivery Specification, Revision 2.0 January 2017. (“‘087 Accused PD Chargers”).

40. Defendant made, used, sold, offered for sale and/or imported a USB power supply (*e.g.*, the ‘087 Accused PD Chargers) comprising power circuitry configured to provide direct current power. This element is met literally, or in the alternative, under the doctrine of equivalents. For example, Defendant provided ‘087 Accused PD Chargers. Each ‘087 Accused PD Charger includes a USB-C port with Power Delivery, through which the ‘087 Accused PD Charger can charge batteries of portable electronic devices using a full featured USB Type-C cable. The ‘087 Accused PD Chargers are configured to connect to portable electronic devices through a full featured USB Type-C cable to provide DC power to the portable electronic devices. Further, the USB-C ports of the ‘087 Accused PD Chargers are compliant with at least Universal Serial Bus Type-C Cable and Connector Specification, Release 1.0 August 2014 (along with other subsequent revisions of Type-C specification), and Universal Serial Bus Power Delivery Specification, Revision 1.0 January 2017. Further, to charge the battery in a portable electronic device, the portable electronic device is connected to the USB power supply. The other end of the USB cable is connected to the charging port of the portable electronic device and the power supply is plugged into a standard wall socket or a DC power source. Therefore, the USB power supply comprises power circuitry to provide DC power to the portable electronic device.

< See all accessories



[Learn more about this accessory](#)

[Write a review](#)



AT&T USB Power Hub 72W with 4 ports (3 USB-C + 1 USB-A)

Special offers (1)



Earn up to \$440 back

AT&T Wireless customers enjoy an exclusive benefit with the AT&T Points Plus® Card from Citi. Terms apply. [Learn how](#)

Color: Black

Overview

With 72W of power, you can safely charge your laptop, phone, tablet, and other devices simultaneously. It's the perfect charger for your home or office, and its compact design and wall plug also makes it ideal for traveling.

Features:

- 3 USB-C ports and 1 USB-A port
- Compact design with wall plug
- Charges four devices at once
- 72W power charges laptops

(E.g., <https://www.att.com/buy/accessories/Chargers/att-usb-power-hub-72w-with-4-ports-3-usb-c-1-usb-a.html>).

ADDING A NEW DEVICE
Customize your accessory

- 1. Pick your accessory
 - 2. **Customize your accessory**
 - 3. Review your cart
- Checkout

< See all accessories



★★★★★ 4.6 | 21 Write a review

AT&T Dual Port 32W Power Delivery Bullet Car Charger (USB-C + USB-A) **\$35.00**

Special offers (1)

Earn up to \$440 back
AT&T Wireless customers enjoy an exclusive benefit with the AT&T Points Plus® Card from Citi. Terms apply. [Learn how](#)

Color: Black



Overview

Easily plugs into your car's charging socket and delivers up to 32W of power to quickly charge your Apple and Android devices. The dual USB ports help power two devices fast and efficiently at the same time.

Features:

- Single USB-C port and single USB-A port
- Compact design with LED power indicator
- Charges two devices simultaneously
- Power delivery optimized for premium Android and Apple devices
- Output: USB-C Port (20W)
- 5VDC/3A; 9VDC/2.22A; 12VDC/1.67A
- PPS Output: 3.3-5.9VDC/3A; 3.3-11VDC/2.22A
- Output: USB-A Port (12W): 5VDC/2.4A
- Input: 12VDC
- USB Power Delivery 3.0 PPS
- 1-year limited warranty

(E.g., <https://www.att.com/buy/accessories/Chargers/att-dual-port-32w-power-delivery-bullet-car-charger-usb-c-plus-usb-a.html?q=usb%20c%20pd>).

ADDING A NEW DEVICE

Customize your accessory

- 1. Pick your accessory
 - 2. Customize your accessory
 - 3. Review your cart
- Checkout

< See all accessories



Write a review



AT&T Dual Port 40W Power Delivery Bullet Car Charger (USB-C + USB-C)

Special offers (1)

Earn up to \$440 back
AT&T Wireless customers enjoy an exclusive benefit with the AT&T Points Plus® Card from Citi. Terms apply.
[Learn how](#)

Color: Black

Easily plugs into your car's charging socket and delivers up to 40W of power to quickly charge your Apple and Android devices. The dual USB ports help power two devices fast and efficiently at the same time.

Features:

- Dual USB-C ports
- Compact design with LED power indicator
- Charges two devices simultaneously
- Power delivery optimized for premium Android and Apple devices
- Output: USB-C Port (20W)
- 5VDC/3A; 9VDC/2.22A; 12VDC/1.67A
- PPS Output: 3.3-5.9VDC/3A; 3.3-11VDC/2.22A
- Output: USB-C Port (20W)
- 5VDC/3A; 9VDC/2.22A; 12VDC/1.67A
- PPS Output: 3.3-5.9VDC/3A; 3.3-11VDC/2.22A
- Input: 12VDC
- USB Power Delivery 3.0 PPS
- 1-year limited warranty

(E.g., <https://www.att.com/buy/accessories/Chargers/att-dual-port-40w-power-delivery-bullet-car-charger-usb-c-plus-usb-c.html?q=usb%20c%20pd>).

ADDING A NEW DEVICE

Customize your accessory



1. Pick your accessory

2. Customize your accessory

3. Review your cart

Checkout

< See all accessories



[Learn more about this accessory](#)

Write a review



AT&T Dual Port 32W Power Delivery Wall Block (USB-C + USB-A)

Special offers (1)



Earn up to \$440 back

AT&T Wireless customers enjoy an exclusive benefit with the AT&T Points Plus® Card from Citi. Terms apply. [Learn how](#)

Color: Black

With a compact design and foldable prongs, this charger easily fits into a purse or pocket and is convenient to take anywhere. The 32W of power safely charges your phone, tablet, and other devices simultaneously.

Features:

- Single USB-C port and Single USB-A port
- Foldable prongs
- Compact design
- Charges two devices simultaneously
- Power Delivery optimized for premium Android and Apple devices
- Output: USB-C (20W)
- 5VDC/3A; 9VDC/2.22A; 12VDC/1.67A
- PPS Output: 3.3-5.9VDC/3A; 3.3-11VDC/2.22A
- Output: USB-A (12W): 5VDC/2.4A
- Input: 100VAC – 240VAC
- USB Power Delivery 3.0 PPS
- 1-year limited warranty

(E.g., <https://www.att.com/buy/accessories/Chargers/att-dual-port-32w-power-delivery-wall-block-usb-c-plus-usb-a.html?q=usb%20c%20pd>).

ADDING A NEW DEVICE

Customize your accessory

- 1. Pick your accessory
 - 2. Customize your accessory
 - 3. Review your cart
- Checkout

< See all accessories



Write a review



AT&T Captive Cable Power Delivery Car Charger 40W with USB-C Port (USB-C)

Special offers (1)



Earn up to \$440 back

AT&T Wireless customers enjoy an exclusive benefit with the AT&T Points Plus® Card from Citi. Terms apply. [Learn how](#)

Color: Black

Easily plugs into your car's charging socket and delivers up to 40W of power to quickly charge two devices simultaneously. Includes a 3-foot attached Type-C cable plus a Single USB-C port to charge all your compatible devices.

Features:

- Compact design with LED power indicator
- Charges two devices simultaneously
- Braided cable and aluminum connector provide extra durability
- Power delivery optimized for premium Android and Apple devices
- Output (each port)
- 5VDC/3A; 9VDC/2.22A; 12VDC/1.67A
- PPS Output: 3.3-5.9VDC/3A; 3.3-11VDC/2.22A
- Input: 12VDC
- USB Power Delivery 3.0 PPS
- 1-year limited warranty

(E.g., <https://www.att.com/buy/accessories/Chargers/att-captive-cable-power-delivery-car-charger-40w-with-usb-c-port-usb-c.html?q=usb%20c%20pd>).

< See all accessories



Write a review



AT&T 10K Power Delivery Portable Battery with USB-C In/Out + USB-A Out

Special offers (1)



Earn up to \$440 back

AT&T Wireless customers enjoy an exclusive benefit with the AT&T Points Plus® Card from Citi. Terms apply. [Learn how](#)

Color: Black

Simultaneously charge two devices at the same time while on-the-go to help keep you fully charged throughout the day. The LED indicator lights signify the charging status and current battery life so you know exactly how much power you have left.

Features:

- Single USB-C port + single USB-A port outputs
- Compact design
- Four LED indicators show battery power level
- Charges two devices simultaneously
- Power delivery output rapidly charges premium Android and Apple devices
- Power Delivery input rapidly re-charges the portable battery
- Output: USB-C (20W): 5VDC/3A; 9VDC/2.22A; 12VDC/1.67A
- USB-A: fast charge 18W
- Maximum 20W
- Input: USB-C 18W PD
- UL approved battery cell
- 1-year limited warranty

(E.g., <https://www.att.com/buy/accessories/Chargers/att-10k-power-delivery-portable-battery-with-usb-c-in-out-plus-usb-a-out.html?q=usb%20c%20pd>).

< See all accessories

♡ 📄



★★★★★ 4.5 | 436 Write a review

AT&T Single Port 30W Power Delivery Wall Block USB-C **\$31.99**

Special offers (1)

 **Earn up to \$440 back**
 AT&T Wireless customers enjoy an exclusive benefit with the AT&T Points Plus® Card from Citi. Terms apply. [Learn how](#)

Color: Black

 Available for pickup at our [Blackstone store](#)

 FREE delivery by Feb 03

[Learn more about this accessory](#)

Overview ^

Your devices deserve a powerful and safe charging experience. This USB-C PD charger brings your battery back to life up to 80% faster than a standard charger. So you're never running on empty for too long.

Videos & images v

Customer Q & A v

Reviews v

Features & specs ^

Key Features

- Single USB-C port
- Foldable prongs
- Compact design

(E.g., <https://www.att.com/buy/accessories/Chargers/att-single-port-30w-power-delivery-wall-block-usb-c.html?q=usb%20c%20pd>).

41. On information and belief, Defendant provided a product or power supply system, such as the '087 Accused PD Chargers, that comprise data circuitry configured to receive a first signal that originates from a portable electronic device and to provide a second signal to be sent to the portable electronic device, the data circuitry and the power circuitry configured to be coupled via a connector to the portable electronic device, the connector comprising a first conductor, a second conductor, a third conductor, and a fourth conductor, the connector configured to be

detachably mated with a power input interface of the portable electronic device. This element is met literally, or in the alternative, under the doctrine of equivalents. For example, the '087 Accused PD Chargers comprise data circuitry as described in the Universal Serial Bus Type-C Cable and Connector Specification and Universal Serial Bus Power Delivery Specification. The '087 Accused PD Chargers are configured to connect to portable electronic devices through a USB cable. The USB cable has a connector of the type including but not limited to USB-C at one end to detachably mate with the charging port of a portable electronic device. The connector comprises VBUS ("first conductor"), GND ("second conductor"), and two Configuration Channel conductors, *i.e.*, CC1/CC2 ("third conductor" / "fourth conductor"). When a portable electronic device is connected to the Accused PD Charger through the full featured USB Type-C cable, the orientation of the connector to the Accused PD Charger is detected first. The Accused PD Chargers detect the proper orientation of the connected USB Type-Cable by checking the voltage signal at the CC1 and CC2 pins. The values of the two resistors, R_p and R_d are fixed such that the voltage signal at one of the two CC pins (*i.e.*, CC1 and CC2) will be lower than the predetermined threshold value. The '087 Accused PD Chargers determine which of the two CC pins are used as a configuration channel by detecting a voltage less than a certain threshold voltage at the CC pin in use. The CC pin used as a configuration channel is the "third conductor" and the voltage signal ("first signal") received at one of the CC pin meeting the threshold requirement from the portable device connected via the full featured USB Type-Cable is determined by the voltage divider signal generated by the R_d resistor in the portable electronic devices with the R_p resistor in the '087 Accused PD Chargers. The CC pin that is not used as a configuration channel then becomes the V_{conn} conductor ("the fourth conductor"). The '087 Accused PD Chargers connect to the full-featured USB Type-C cables that are electronically marked. To connect to an electronically

marked USB Type-C cable, the ‘087 Accused PD Chargers utilize the Vconn pin. With the electronically marked USB Type-Cable, the CC pin not used as the configuration channel is used as the Vconn source. Upon providing the Vconn signal to the portable electronic device, the ‘087 Accused PD Chargers communicate the SOP/SOP’/SOP’’ (SOP*) packet with the portable electronic device that is used to control the power delivery from the Accused PD Chargers to the portable electronic device. The SOP* includes the SOP communication from the Accused PD Chargers to the portable electronic devices that are attached. The voltage signal at the Vconn pin sent from the Accused PD Chargers to the portable electronic devices is the “second signal” because the Vconn signal enables the SOP* communication that controls the charging batteries in the portable electronic devices.

Table 3-4 USB Type-C Receptacle Interface Pin Assignments

Pin	Signal Name	Description	Mating Sequence	Pin	Signal Name	Description	Mating Sequence
A1	GND	Ground return	First	B12	GND	Ground return	First
A2	SSTXp1	Positive half of first SuperSpeed TX differential pair	Second	B11	SSRXp1	Positive half of first SuperSpeed RX differential pair	Second
A3	SSTXn1	Negative half of first SuperSpeed TX differential pair	Second	B10	SSRXn1	Negative half of first SuperSpeed RX differential pair	Second
A4	Vbus	Bus Power	First	B9	Vbus	Bus Power	First
A5	CC1	Configuration Channel	Second	B8	SBU2	Sideband Use (SBU)	Second
A6	Dp1	Positive half of the USB 2.0 differential pair - Position 1	Second	B7	Dn2	Negative half of the USB 2.0 differential pair - Position 2	Second
A7	Dn1	Negative half of the USB 2.0 differential pair - Position 1	Second	B6	Dp2	Positive half of the USB 2.0 differential pair - Position 2	Second
A8	SBU1	Sideband Use (SBU)	Second	B5	CC2	Configuration Channel	Second
A9	Vbus	Bus Power	First	B4	Vbus	Bus Power	First
A10	SSRXn2	Negative half of second SuperSpeed RX differential pair	Second	B3	SSTXn2	Negative half of second SuperSpeed TX differential pair	Second
A11	SSRXp2	Positive half of second SuperSpeed RX differential pair	Second	B2	SSTXp2	Positive half of second SuperSpeed TX differential pair	Second
A12	GND	Ground return	First	B1	GND	Ground return	First

(E.g., Universal Serial Bus Type-C Cable and Connector Specification Revision 1.0 August 2014, Page 49).

The USB Type-C receptacle, plug and cable designs are intended to support future USB functional extensions. As such, consideration was given to frequency scaling performance, pin-out arrangement and the configuration mechanisms when developing this solution. The definition of future USB functional extensions is not in the scope of this specification but rather will be provided in future releases of the base USB Specification, i.e., beyond the existing [USB 3.1 Specification](#).

Figure 2-1 illustrates the comprehensive functional signal plan for the USB Type-C receptacle, not all signals shown are required in all platforms or devices. As shown, the receptacle signal list functionally delivers both [USB 2.0](#) (D+ and D-) and [USB 3.1](#) (TX and RX pairs) data buses, USB power (VBUS) and ground (GND), [Configuration Channel](#) signals (CC1 and CC2), and two Sideband Use (SBU) signal pins. Multiple sets of USB data bus signal locations in this layout facilitate being able to functionally map the USB signals independent of plug orientation in the receptacle. For reference, the signal pins are labeled.

(E.g., Universal Serial Bus Type-C Cable and Connector Specification, Release 1.0 August 2014, Page 18).

Figure 2-1 USB Type-C Receptacle Interface (Front View)

A1	A2	A3	A4	A5	A6	A7	A8	A9	A10	A11	A12
GND	TX1+	TX1-	VBUS	CC1	D+	D-	SBU1	VBUS	RX2-	RX2+	GND
GND	RX1+	RX1-	VBUS	SBU2	D-	D+	CC2	VBUS	TX2-	TX2+	GND
B12	B11	B10	B9	B8	B7	B6	B5	B4	B3	B2	B1

(E.g., Universal Serial Bus Type-C Cable and Connector Specification Revision 1.0 August 2014, Page 18).

4.5.1.1 USB Data Bus Interface and USB Type-C Plug Flip-ability

Since the USB Type-C plug can be inserted in either right-side-up or upside-down position, the hosts and devices that support USB data bus functionality must operate on the signal pins that are actually connected end-to-end. In the case of USB 2.0, this is done by shorting together the two D+ signal pins and the two D- signal pins in the DFP and UFP receptacles. In the case of USB SuperSpeed signals, it requires the functional equivalent of a switch in both the DFP and UFP to appropriately route the SuperSpeed TX and RX signal pairs to the connected path through the cable.

(E.g., Universal Serial Bus Type-C Cable and Connector Specification Revision 1.0 August 2014, Page 104).

Figure 4-3 Logical Model for Data Bus Routing across USB Type-C-based Ports

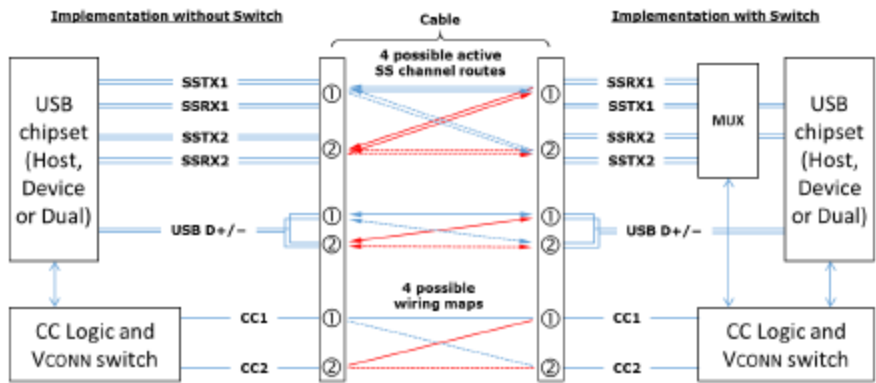

(E.g., Universal Serial Bus Type-C Cable and Connector Specification Revision 1.0 August 2014, Page 105).

4.5.1.2.1 Detecting a Valid DFP-to-UFP Connection

The general concept for setting up a valid connection between a DFP and UFP is based on being able to detect terminations residing in the product being attached.

To aid in defining the functional behavior of CC, a pull-up (R_p) and pull-down (R_d) termination model is used – actual implementation in hosts and devices may vary, for example, the pull-up termination could be replaced by a current source. Figure 4-5 and Figure 4-6 illustrates two models, the first based on a pull-up resistor in the DFP and the second replacing this with a current source.

Figure 4-5 Pull-Up/Pull-Down CC Model

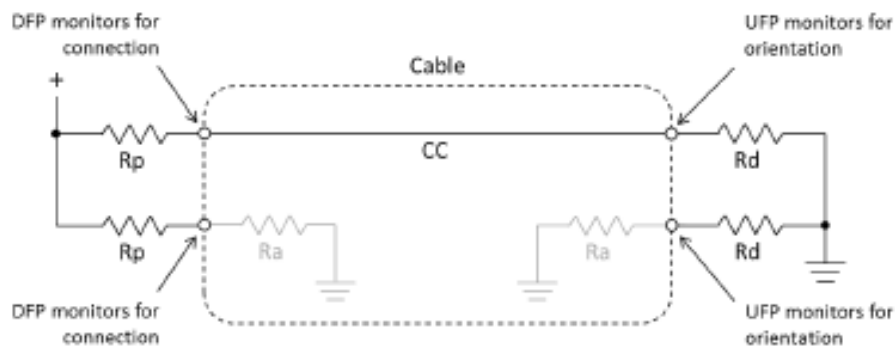

(E.g., Universal Serial Bus Type-C Cable and Connector Specification Revision 1.0 August 2014, Page 107).

Table 4-10 provides the values that shall be used for the DFP's R_p or current source. Other pull-up voltages shall be allowed if they remain less than 5.5 V and fall within the correct voltage ranges on the UFP side - see Table 4-18, Table 4-19 and Table 4-20. Note: when two DFPs are connected together, they may use different termination methods which could result in unexpected current flow.

Table 4-10 DFP CC Termination (R_p) Requirements

DFP Advertisement	Current Source to 1.7 - 5.5 V	Resistor pull-up to 4.75 - 5.5 V	Resistor pull-up to 3.3 V \pm 5%
Default USB Power	80 μ A \pm 20%	56 k Ω \pm 20%	36 k Ω \pm 20%
1.5 A @ 5 V	180 μ A \pm 8%	22 k Ω \pm 5%	12 k Ω \pm 5%
3.0 A @ 5 V	330 μ A \pm 8%	10 k Ω \pm 5%	4.7 k Ω \pm 5%

The UFP may find it convenient to implement R_d in multiple ways simultaneously (a wide range R_d when unpowered and a trimmed R_d when powered). Transitions between R_d implementations that do not exceed $t_{CCDebounce}$ shall not be interpreted as exceeding the wider R_d range. Table 4-11 provides the methods and values that shall be used for the UFP's R_d implementation.

Table 4-11 UFP CC Termination (R_d) Requirements

R_d Implementation	Nominal value	Can detect power capability?	Max voltage on pin
\pm 20% voltage clamp ¹	1.1 V	No	1.32 V
\pm 20% resistor to GND	5.1 k Ω	No	2.18 V
\pm 10% resistor to GND	5.1 k Ω	Yes	2.04 V

Note:

1. The clamp implementation inhibits USB PD communication although the system can start with the clamp and transition to the resistor once it is able to do USB PD.

(E.g., Universal Serial Bus Type-C Cable and Connector Specification Revision 1.0 August 2014, Pages 149-150).

2.5 VCONN

Once the connection between host and device is established, the CC pin (CC1 or CC2) in the receptacle that is not connected via the CC wire through the standard cable is repurposed to source VCONN to power circuits in the plug needed to implement Electronically Marked Cables (see Section 4.9). Initially, the DFP sources VCONN and the source may be swapped using USB PD VCONN_Swap.

Electronically marked cables may use VBUS instead of VCONN as VBUS is available across the cable. VCONN functionally differs from VBUS in that it is isolated from the other end of the cable. VCONN is independent of VBUS and, unlike VBUS which can use USB PD to support higher voltages, VCONN voltage is fixed at 5 V.

(E.g., Universal Serial Bus Type-C Cable and Connector Specification Revision 1.0 August 2014, Page 23).

4.9 Electronically Marked Cables

All USB Full-Featured Type-C cables shall be electronically marked. USB 2.0 Type-C cables may be electronically marked.

Electronically marked cables shall support *USB Power Delivery* Structured VDM Discover Identity command directed to SOP'. This provides a method to determine the characteristics of the cable, e.g. its current carrying capability, its performance, vendor identification, etc. This may be referred to as the USB Type-C Cable ID function.

Prior to an explicit *USB PD* contract, a Charging UFP is allowed to use SOP' to discover the cable's identity. After an explicit *USB PD* contract has been negotiated, only the DFP shall communicate with SOP'.

An electronically marked cable incorporates electronics that require VCONN, although VBUS or another source may be used. Electronically marked cables that do not incorporate data bus signal conditioning circuits shall consume no more than 70 mW from VCONN. During USB suspend, electronically marked cables shall not draw more than 7.5 mA from VCONN, see Section 4.6.1.2.

(E.g., Universal Serial Bus Type-C Cable and Connector Specification Revision 1.0 August 2014, Page 147).

Figure 4-34 Electronically Marked Cable with VCONN connected through the cable

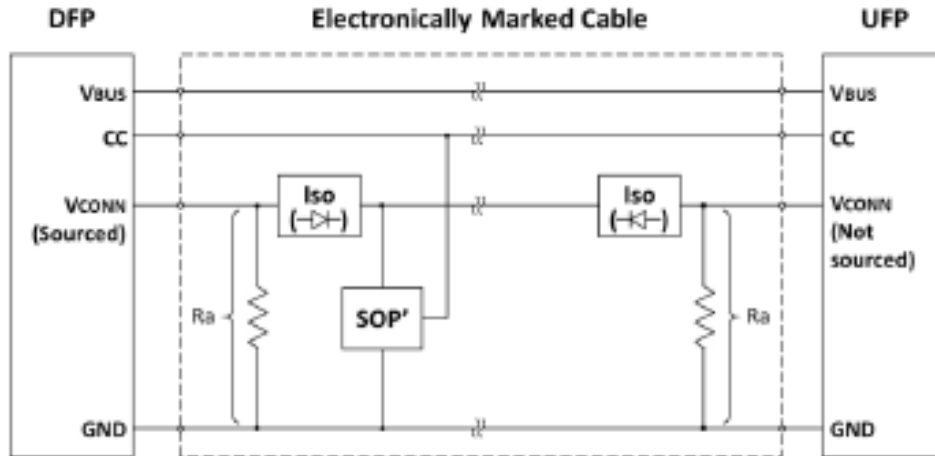

(E.g., Universal Serial Bus Type-C Cable and Connector Specification Revision 1.0 August 2014, Page 148).

Figure 4-35 Electronically Marked Cable with SOP' at both ends

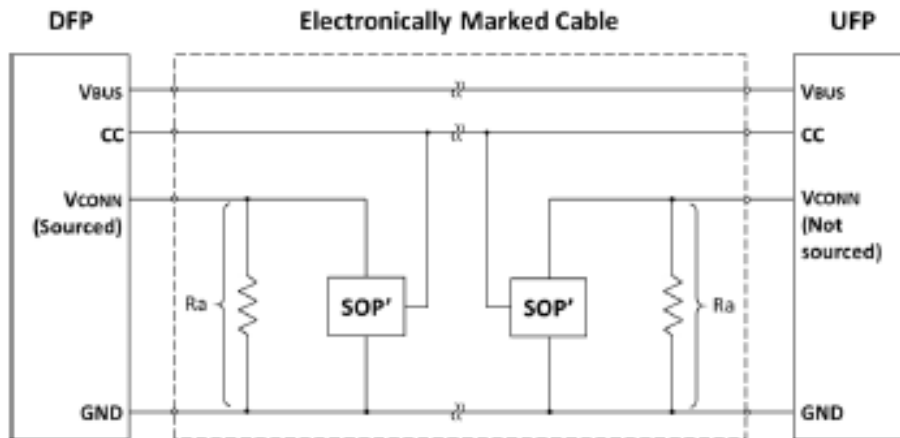

(E.g., Universal Serial Bus Type-C Cable and Connector Specification Revision 1.0 August 2014, Page 147).

All SOP* Communications take place over a single wire (CC). This means that the SOP* Communication periods must be coordinated to prevent important communication from being blocked. For a product which does not recognize SOP/SOP' or SOP'' Packets, this will look like a non-idle channel, leading to missed packets and retries. Communications between the Port Partners take precedence meaning that communications with the Cable Plug can be interrupted but will not lead to a Soft or Hard Reset.

When no Contract or an Implicit Contract is in place (e.g., after a Power Role Swap or Fast Role Swap) only the Source port that is supplying VCONN is allowed to send packets to a Cable Plug (SOP') and is allowed to respond to packets from the Cable Plug (SOP') with a GoodCRC in order to discover the Cable Plug's characteristics (see Figure 2-2). During this phase all communication with the Cable Plug is initiated and controlled by the Source which acts to prevent conflicts between SOP and SOP' Packets. The Sink does not communicate with the Cable Plug and Discards any SOP' Packets received.

When an Explicit Contract is in place the VCONN Source (either the DFP or the UFP) can communicate with the Cable Plug(s) using SOP'/SOP'' Packets (see Figure 2-2). During this phase all communication with the Cable Plug is initiated and controlled by the VCONN Source which acts to prevent conflicts between SOP* Packets. The Port that is not the VCONN Source does not communicate with the Cable Plug and does not recognize any SOP'/SOP'' Packets received. Only the DFP, when acting as a VCONN Source, is allowed to send SOP* in order to control the entry and exiting of Modes and to manage Modal Operation.

Figure 2-2 Example SOP' Communication between VCONN Source and Cable Plug(s)

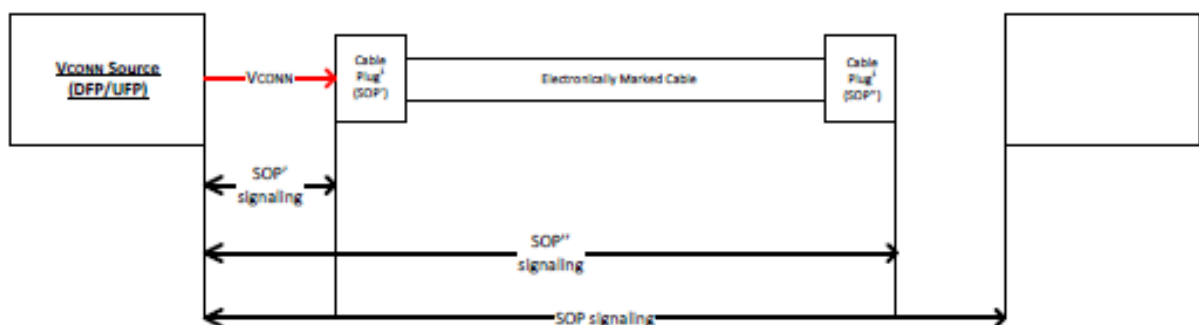

(E.g., Universal Serial Bus Power Delivery Specification Revision 3.1, April 2022, Page 7).

Term	Description
Sink Directed Charge	A charging scheme whereby the Sink connects the Source to its battery through safety and other circuitry. When the SPR PPS Current Limit feature is activated, the Source automatically controls its output current by adjusting its output Voltage.
Soft Reset	A process that resets the PD communications engine to its default state.
SOP Communication	Communication using SOP Packets also implies that a Message sequence is being followed.
SOP Packet	Any Power Delivery Packet which starts with an <i>SOP</i> .
SOP* Communication	Communication with a Cable Plug using SOP* Packets, also implies a Message sequence is being followed.
SOP* Packet	A term referring to any Power Delivery Packet starting with either <i>SOP</i> , <i>SOP*</i> or <i>SOP''</i> .
SOP' Communication	Communication with a Cable Plug using SOP' Packets, also implies that a Message sequence is being followed.
SOP' Packet	Any Power Delivery Packet which starts with an <i>SOP'</i> used to communicate with a Cable Plug.
SOP'' Communication	Communication with a Cable Plug using SOP'' Packets, also implies that a Message sequence is being followed.
SOP'' Packet	Any Power Delivery Packet which starts with an <i>SOP''</i> used to communicate with a Cable Plug when SOP' Packets are being used to communicate with the other Cable Plug.

(Universal Serial Bus Power Delivery Specification Revision 3.1, April 2022, Page 68).

42. On information and belief, Defendant provided a product or power supply system, such as '087 Accused PD Chargers, to transfer, via the first conductor, the direct current power to the portable electronic device. This element is met literally, or in the alternative, under the doctrine of equivalents. For example, the VBUS pin is the voltage line that provides DC power to the portable electronic device.

Figure 2-1 illustrates the comprehensive functional signal plan for the USB Type-C receptacle, not all signals shown are required in all platforms or devices. As shown, the receptacle signal list functionally delivers both [USB 2.0](#) (D+ and D-) and [USB 3.1](#) (TX and RX pairs) data buses, **USB power (VBUS) and ground (GND)**, [Configuration Channel](#) signals (CC1 and CC2), and two Sideband Use (SBU) signal pins. Multiple sets of USB data bus signal locations in this layout facilitate being able to functionally map the USB signals independent of plug orientation in the receptacle. For reference, the signal pins are labeled.

Figure 2-1 USB Type-C Receptacle Interface (Front View)

A1	A2	A3	A4	A5	A6	A7	A8	A9	A10	A11	A12
GND	TX1+	TX1-	VBUS	CC1	D+	D-	SBU1	VBUS	RX2-	RX2+	GND
GND	RX1+	RX1-	VBUS	SBU2	D-	D+	CC2	VBUS	TX2-	TX2+	GND
B12	B11	B10	B9	B8	B7	B6	B5	B4	B3	B2	B1

(E.g., Universal Serial Bus Type-C Cable and Connector Specification, Release 1.0 August 2014,

Page 18).

2.4 VBus

VBus provides a path to deliver power between a host and a device, and between a charger and a host/device. A simplified high-current supply capability is defined for hosts and chargers that optionally support current levels beyond the [USB 2.0](#) and [USB 3.1](#) specifications. The [USB Power Delivery Specification](#) is supported.

Table 2-1 summarizes the power supply options available from the perspective of a device with the USB Type-C connector. Not all options will be available to the device from all host

(E.g., Universal Serial Bus Type-C Cable and Connector Specification Revision 1.0 August 2014, Page 22).

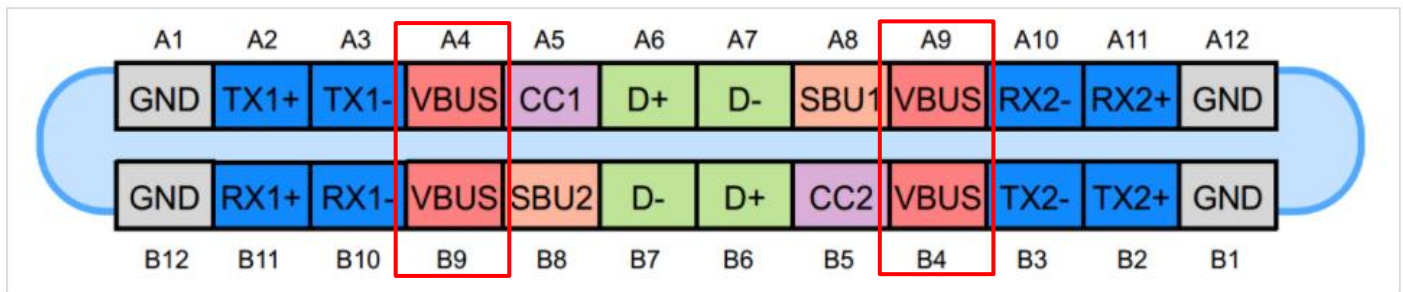

Figure 1. The USB Type-C receptacle. Image courtesy of *Microchip*.

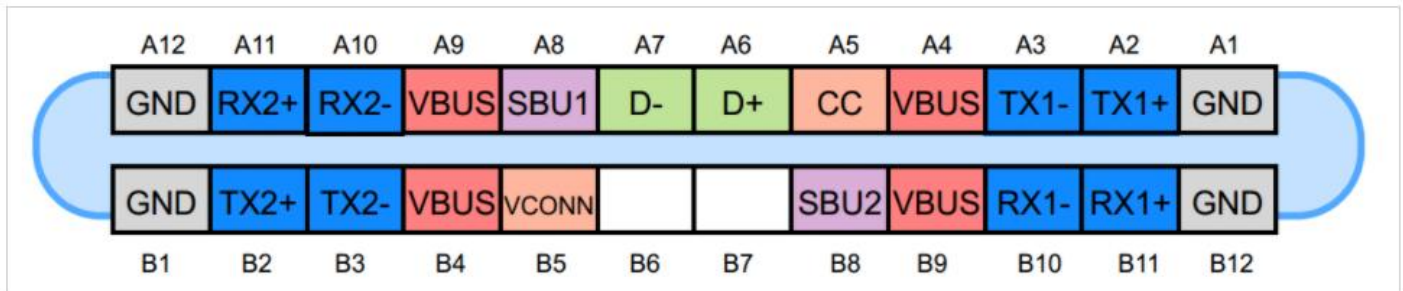

Figure 2. The USB Type-C plug. Image courtesy of *Microchip*.

(E.g., <https://www.allaboutcircuits.com/technical-articles/introduction-to-usb-type-c-which-pins-power-delivery-data-transfer/>).

43. Defendant provided a product or power supply system, such as ‘087 Accused PD Chargers, to transfer, via the second conductor, a ground reference to the portable electronic

device. This element is met literally, or in the alternative, under the doctrine of equivalents. For example, the GND pin provides a ground reference to the portable electronic device.

2.3.1 DFP-to-UFP Attach/Detach Detection

Initially, DFP-to-UFP attach is detected by a host or hub port (DFP) when one of the CC pins at its USB Type-C receptacle senses a specified resistance to GND. Subsequently, DFP-to-UFP detach is detected when the CC pin that was terminated at its USB Type-C receptacle is no longer terminated to GND.

Power is not applied to the USB Type-C host or hub receptacle (VBUS or VCONN) until the DFP detects the presence of an attached device (UFP) port. When a DFP-to-UFP attach is detected, the DFP is expected to enable power to the receptacle and proceed to normal USB operation with the attached device. When a DFP-to-UFP detach is detected, the port sourcing VBUS removes power.

(E.g., Universal Serial Bus Type-C Cable and Connector Specification, Release 1.0 August 2014, Page 21).

Table 3-4 USB Type-C Receptacle Interface Pin Assignments

Pin	Signal Name	Description	Mating Sequence	Pin	Signal Name	Description	Mating Sequence
A1	GND	Ground return	First	B12	GND	Ground return	First

(E.g., Universal Serial Bus Type-C Cable and Connector Specification Revision 1.0 August 2014, Page 49).

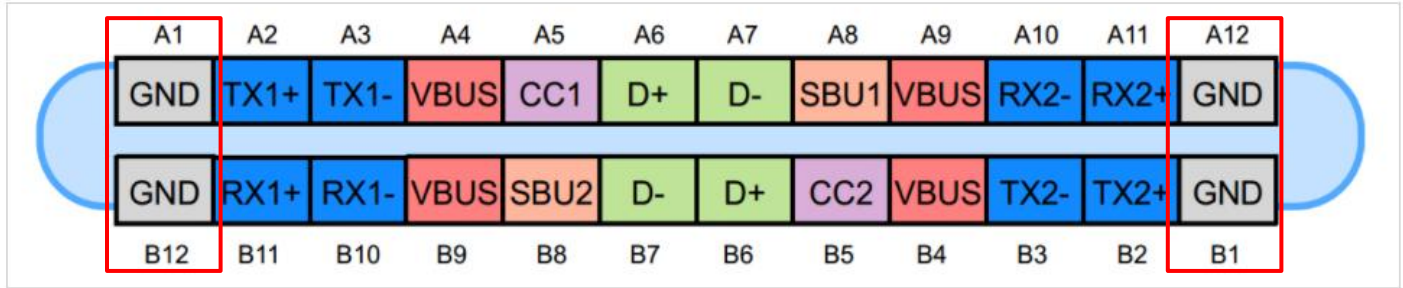

Figure 1. The USB Type-C receptacle. Image courtesy of Microchip.

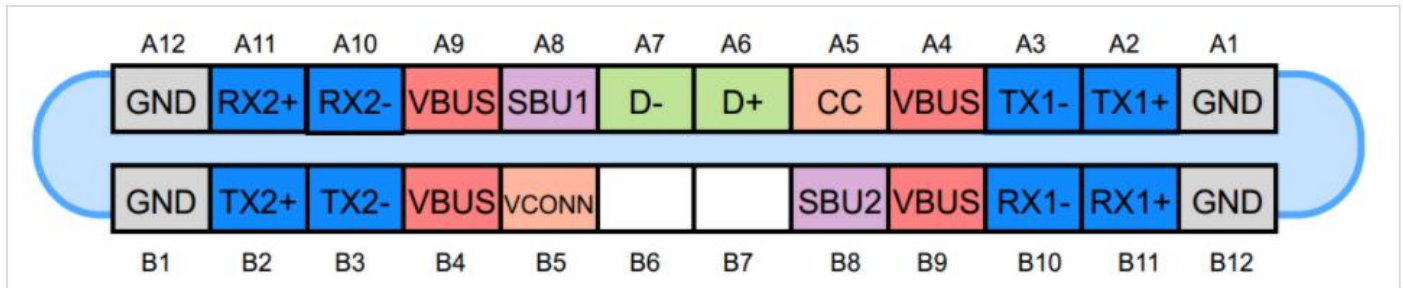

Figure 2. The USB Type-C plug. Image courtesy of Microchip.

(E.g., <https://www.allaboutcircuits.com/technical-articles/introduction-to-usb-type-c-which-pins-power-delivery-data-transfer/>).

44. Defendant provided a product or power supply system, such as ‘087 Accused PD Chargers, to transfer, via the third conductor, the first signal from the portable electronic device to the data circuitry. This element is met literally, or in the alternative, under the doctrine of equivalents. When a portable electronic device is connected to an ‘087 Accused PD Charger through the USB Type-C cable, the orientation of the connector to the ‘087 Accused PD Charger is detected first. The ‘087 Accused PD Chargers detect the proper orientation of the connected USB Type-Cable by checking the voltage signal at the CC1 and CC2 pins. The values of the two resistors, Rp and Rd are fixed such that the voltage signal at one of the two CC pins (i.e., CC1 and CC2) will be lower than the predetermined threshold value. The ‘087 Accused PD Chargers determine which of the two CC pins are used as the configuration channel by detecting a voltage

less than a certain threshold voltage at the CC pin in use. The CC pin used as the configuration channel is the “third conductor” and the voltage signal received at one of the CC pins meeting the threshold requirement (“first signal”) from the portable electronic device connected via the full featured USB Type-Cable is determined by the voltage divider signal generated by the R_d resistor in the portable electronic devices with the R_p resistor in the ‘087 Accused PD Chargers.

4.5.1.2.1 Detecting a Valid DFP-to-UFP Connection

The general concept for setting up a valid connection between a DFP and UFP is based on being able to detect terminations residing in the product being attached.

To aid in defining the functional behavior of CC, a pull-up (R_p) and pull-down (R_d) termination model is used – actual implementation in hosts and devices may vary, for example, the pull-up termination could be replaced by a current source. Figure 4-5 and Figure 4-6 illustrates two models, the first based on a pull-up resistor in the DFP and the second replacing this with a current source.

Figure 4-5 Pull-Up/Pull-Down CC Model

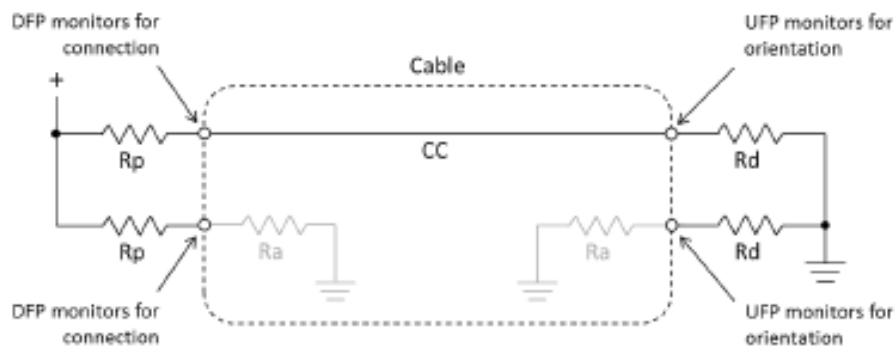

(E.g., Universal Serial Bus Type-C Cable and Connector Specification Revision 1.0 August 2014, Page107).

Table 4-10 provides the values that shall be used for the DFP's R_p or current source. Other pull-up voltages shall be allowed if they remain less than 5.5 V and fall within the correct voltage ranges on the UFP side - see Table 4-18, Table 4-19 and Table 4-20. Note: when two DFPs are connected together, they may use different termination methods which could result in unexpected current flow.

Table 4-10 DFP CC Termination (R_p) Requirements

DFP Advertisement	Current Source to 1.7 - 5.5 V	Resistor pull-up to 4.75 - 5.5 V	Resistor pull-up to 3.3 V \pm 5%
Default USB Power	80 μ A \pm 20%	56 k Ω \pm 20%	36 k Ω \pm 20%
1.5 A @ 5 V	180 μ A \pm 8%	22 k Ω \pm 5%	12 k Ω \pm 5%
3.0 A @ 5 V	330 μ A \pm 8%	10 k Ω \pm 5%	4.7 k Ω \pm 5%

The UFP may find it convenient to implement R_d in multiple ways simultaneously (a wide range R_d when unpowered and a trimmed R_d when powered). Transitions between R_d implementations that do not exceed $t_{CCDebounce}$ shall not be interpreted as exceeding the wider R_d range. Table 4-11 provides the methods and values that shall be used for the UFP's R_d implementation.

Table 4-11 UFP CC Termination (R_d) Requirements

R_d Implementation	Nominal value	Can detect power capability?	Max voltage on pin
\pm 20% voltage clamp ¹	1.1 V	No	1.32 V
\pm 20% resistor to GND	5.1 k Ω	No	2.18 V
\pm 10% resistor to GND	5.1 k Ω	Yes	2.04 V

Note:

1. The clamp implementation inhibits [USB PD](#) communication although the system can start with the clamp and transition to the resistor once it is able to do [USB PD](#).

(E.g., Universal Serial Bus Type-C Cable and Connector Specification Revision 1.0 August 2014, Pages 149-150).

45. Defendant provided a product or power supply system, such as ‘087 Accused PD Chargers, to transfer, via the fourth conductor, the second signal from the data circuitry to the portable electronic device. This element is met literally, or in the alternative, under the doctrine of equivalents. The CC pin that is not used as a configuration channel then becomes the Vconn conductor (“the fourth conductor”). The Accused PD Chargers connect to the full-featured USB Type-C cables that are electronically marked. To connect to an electronically marked USB Type-C cable, the Accused PD Chargers utilize the Vconn pin. With the electronically marked USB Type-Cable, the CC pin not used for the configuration is used as the Vconn source. Upon providing the Vconn source, the Accused PD Chargers communicate the SOP* packets with the

portable electronic device, which control charging of the batteries in the portable electronic devices. The SOP* includes the SOP communication from the Accused PD Chargers to the portable devices that are attached. The voltage signal sent at the Vconn pin from the Accused PD Chargers to the portable electronic devices is the “second signal” because this voltage signal enables the SOP* communication that controls charging batteries in the portable electronic devices.

2.5 VCONN

Once the connection between host and device is established, the CC pin (CC1 or CC2) in the receptacle that is not connected via the CC wire through the standard cable is repurposed to source VCONN to power circuits in the plug needed to implement Electronically Marked Cables (see Section 4.9). Initially, the DFP sources VCONN and the source may be swapped using [USB PD VCONN_Swap](#).

Electronically marked cables may use VBUS instead of VCONN as VBUS is available across the cable. VCONN functionally differs from VBUS in that it is isolated from the other end of the cable. VCONN is independent of VBUS and, unlike VBUS which can use [USB PD](#) to support higher voltages, VCONN voltage is fixed at 5 V.

(E.g., Universal Serial Bus Type-C Cable and Connector Specification Revision 1.0 August 2014, Page 23).

4.9 Electronically Marked Cables

All USB Full-Featured Type-C cables shall be electronically marked. USB 2.0 Type-C cables may be electronically marked.

Electronically marked cables shall support [USB Power Delivery](#) Structured VDM Discover Identity command directed to SOP'. This provides a method to determine the characteristics of the cable, e.g. its current carrying capability, its performance, vendor identification, etc. This may be referred to as the USB Type-C Cable ID function.

Prior to an explicit [USB PD](#) contract, a Charging UFP is allowed to use SOP' to discover the cable's identity. After an explicit [USB PD](#) contract has been negotiated, only the DFP shall communicate with SOP'.

An electronically marked cable incorporates electronics that require VCONN, although VBUS or another source may be used. Electronically marked cables that do not incorporate data bus signal conditioning circuits shall consume no more than 70 mW from VCONN. During USB suspend, electronically marked cables shall not draw more than 7.5 mA from VCONN, see Section 4.6.1.2.

(E.g., Universal Serial Bus Type-C Cable and Connector Specification Revision 1.0 August

2014, Page 147).

Figure 4-34 Electronically Marked Cable with VCONN connected through the cable

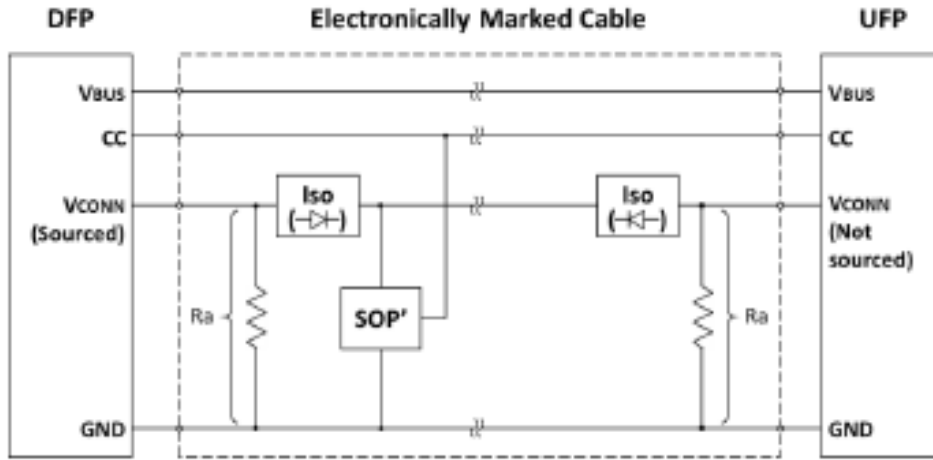

(E.g., Universal Serial Bus Type-C Cable and Connector Specification Revision 1.0 August 2014, Page 148).

Figure 4-35 Electronically Marked Cable with SOP' at both ends

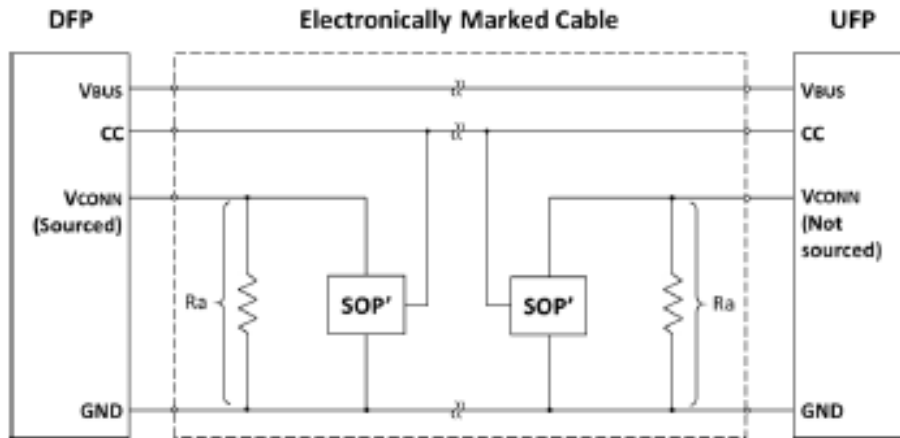

(E.g., Universal Serial Bus Type-C Cable and Connector Specification Revision 1.0 August 2014, Page 147).

All SOP* Communications take place over a single wire (CC). This means that the SOP* Communication periods must be coordinated to prevent important communication from being blocked. For a product which does not recognize SOP/SOP' or SOP'' Packets, this will look like a non-idle channel, leading to missed packets and retries. Communications between the Port Partners take precedence meaning that communications with the Cable Plug can be interrupted but will not lead to a Soft or Hard Reset.

When no Contract or an Implicit Contract is in place (e.g., after a Power Role Swap or Fast Role Swap) only the Source port that is supplying VCONN is allowed to send packets to a Cable Plug (SOP') and is allowed to respond to packets from the Cable Plug (SOP') with a GoodCRC in order to discover the Cable Plug's characteristics (see Figure 2-2). During this phase all communication with the Cable Plug is initiated and controlled by the Source which acts to prevent conflicts between SOP and SOP' Packets. The Sink does not communicate with the Cable Plug and Discards any SOP' Packets received.

When an Explicit Contract is in place the VCONN Source (either the DFP or the UFP) can communicate with the Cable Plug(s) using SOP'/SOP'' Packets (see Figure 2-2). During this phase all communication with the Cable Plug is initiated and controlled by the VCONN Source which acts to prevent conflicts between SOP* Packets. The Port that is not the VCONN Source does not communicate with the Cable Plug and does not recognize any SOP'/SOP'' Packets received. Only the DFP, when acting as a VCONN Source, is allowed to send SOP* in order to control the entry and exiting of Modes and to manage Modal Operation.

Figure 2-2 Example SOP' Communication between VCONN Source and Cable Plug(s)

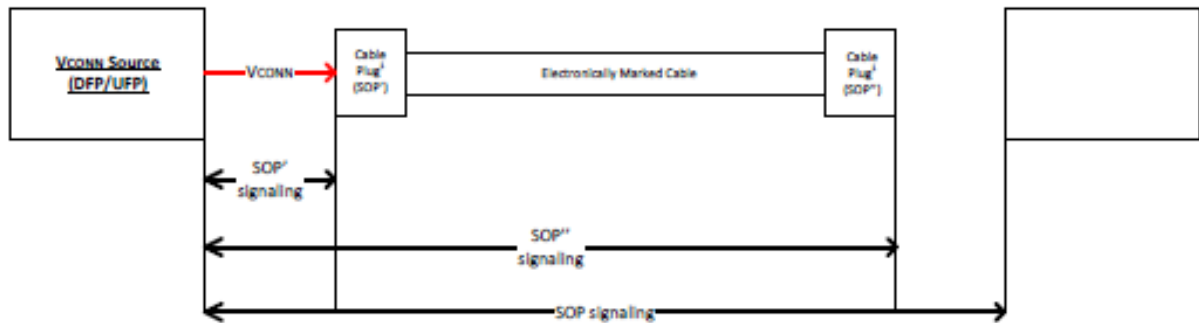

(E.g., Universal Serial Bus Power Delivery Specification Revision 3.1, April 2022, Page 7).

Term	Description
Sink Directed Charge	A charging scheme whereby the Sink connects the Source to its battery through safety and other circuitry. When the SPR PPS Current Limit feature is activated, the Source automatically controls its output current by adjusting its output Voltage.
Soft Reset	A process that resets the PD communications engine to its default state.
SOP Communication	Communication using SOP Packets also implies that a Message sequence is being followed.
SOP Packet	Any Power Delivery Packet which starts with an <i>SOP</i> .
SOP* Communication	Communication with a Cable Plug using SOP* Packets, also implies a Message sequence is being followed.
SOP* Packet	A term referring to any Power Delivery Packet starting with either <i>SOP</i> , <i>SOP'</i> or <i>SOP''</i> .
SOP' Communication	Communication with a Cable Plug using SOP' Packets, also implies that a Message sequence is being followed.
SOP' Packet	Any Power Delivery Packet which starts with an <i>SOP'</i> used to communicate with a Cable Plug.
SOP'' Communication	Communication with a Cable Plug using SOP'' Packets, also implies that a Message sequence is being followed.
SOP'' Packet	Any Power Delivery Packet which starts with an <i>SOP''</i> used to communicate with a Cable Plug when SOP' Packets are being used to communicate with the other Cable Plug.

(E.g., Universal Serial Bus Power Delivery Specification Revision 3.1, April 2022, Page 68).

46. Defendant provided a product or power supply system, such as ‘087 Accused PD Chargers, that has data circuitry that is further configured, in coordination with the first signal, to provide the second signal, the second signal having a parameter level that is usable by the portable electronic device in connection with control of charging a rechargeable battery of the portable electronic device based on the direct current power provided by the power circuitry. This element is met literally, or in the alternative, under the doctrine of equivalents. As explained above, a voltage signal meeting the specified threshold value, i.e., the “first signal,” is detected at the CC pin used as the configuration channel. In coordination with this voltage signal, the second signal, i.e., another voltage signal from the Vconn pin is sent from the ‘087 Accused PD Chargers to the portable electronic devices, which enables the SOP* communication that controls charging a rechargeable battery of the portable electronic device.

2.5.3 SOP Communication

SOP Communication is used for Port-to-Port communication between the Source and the Sink. SOP Communication is recognized by both Port Partners but not by any intervening Cable Plugs. SOP Communication takes priority over other SOP* Communications since it is critical to complete power related operations as soon as possible. Message sequences relating to power are also allowed to interrupt other sequences to ensure that negotiation and control of power is given priority on the bus.

(E.g., Universal Serial Bus Power Delivery Specification Revision 3.1, April 2022, Page 75).

6.4.1.1 Use of the Capabilities Message

6.4.1.1.1 Use by Sources

Sources send a *Source_Capabilities* Message (see Section 6.4.1) either as part of advertising Port capabilities, or in response to a *Get_Source_Cap* Message.

Following a Hard Reset, a power-on event or plug insertion event, a Source Port *Shall* send a *Source_Capabilities* Message after every *SourceCapabilityTimer* timeout as an Advertisement that *Shall* be interpreted by the Sink Port on Attachment. The Source *Shall* continue sending a minimum of *nCapsCount* *Source_Capabilities* Messages until a *GoodCRC* Message is received.

(E.g., Universal Serial Bus Power Delivery Specification Revision 3.1, April 2022, Page 146).

B. Indirect Infringement

47. Upon information and belief, Defendant was indirectly infringing by way of inducing infringement and contributing to the infringement of the asserted claims of the '087 patent in the State of Texas, in this District, and elsewhere in the United States, by providing the '087 Accused Chargers for use as described above by Defendant's customers. Defendant advertised, offered for sale, and/or sold the '087 Accused Chargers to its customers for use in a manner that Defendant knew infringed at least one claim of the '087 patent. For example, Defendant advertised and sold the '087 Accused Chargers. Defendant is a direct and indirect infringer, and its customers using the '087 Accused Chargers are direct infringers. Defendant had actual knowledge of the '087 patent at least as early as when they received letters from Plaintiff sent on August 1, 2023, and April 13, 2024, asserting that the '087 Accused Chargers infringed claims of the '087 patent and they were provided a claim chart that provided evidence of the infringement. Defendant has known of its infringement since at least that date as a result of the accusations of infringement in the notice letters. Defendant has therefore also known that the use of the '087 Accused Chargers by its customers infringed at least one claim of the '087 patent since at least the date they received the letters.

48. On information and belief, since Defendant became aware of the '087 patent and of the infringement through advertising and offering for sale the '087 Accused Chargers for use by its customers, Defendant was committing the act of inducing infringement by specifically intending to induce infringement by providing the '087 Accused Chargers to its customers and by aiding and abetting its use in a manner known to infringe by Defendant. Since Defendant became aware of the infringing use of the '087 Accused Chargers, Defendant knew that the use of the '087 Accused Chargers by its customers as a charger with a portable electronic device (including a

rechargeable battery) constituted direct patent infringement. Despite this knowledge, Defendant continued to encourage and induce its customers to use the '087 Accused Chargers to infringe as described above and provided instructions for using the '087 Accused Chargers to infringe, including through advertisements. Defendant therefore knowingly induced infringement and specifically intended to encourage and induce the infringement of the '087 patent by its customers.

49. On information and belief, since Defendant became aware of the acts of infringement at least as of the date of receipt of the notice letters, Defendant was committing the act of contributory infringement by intending to provide the '087 Accused Chargers to its customers knowing that such devices are a material part of the claimed invention, knowing that its use was made and adapted for infringement of the '087 patent as described above, and further knowing that the accused aspect of the '087 Accused Chargers described above is not a staple article or commodity of commerce suitable for substantially noninfringing use. As described above, Defendant was aware that all material claim limitations are satisfied by the use and implementation of the '087 Accused Chargers by Defendant's customers in the manner described above yet continued to provide the Accused Chargers to its customers knowing that it is a material part of the claimed invention. As described above, since learning of the infringement, Defendant knew that the use and implementation of the '087 Accused Chargers by its customers was made and adapted for infringement of the '087 patent. A new act of direct infringement occurred each time a customer implemented and/or used the '087 Accused Chargers in the manner described above. After Defendant became aware that the use of the '087 Accused Chargers infringed at least one claim of the '087 patent, Defendant knew that each such new use was made and adapted for infringement of at least one claim of the '087 patent and Defendant continued to advertise and provide the '087 Accused Chargers for such infringing activities. Furthermore, as described more

fully above, the '087 Accused Chargers have functionality designed for use in a system in the manner described above and is therefore not a staple article or commodity of commerce suitable for substantially noninfringing use.

50. Upon information and belief, Defendant was willfully infringing the asserted claims of the '087 patent in Texas, in this District, and elsewhere in the United States. Defendant had actual knowledge of the '087 patent at least as early as when they received letters from Plaintiff sent on August 1, 2023, and April 13, 2024, asserting that the '087 Accused Chargers infringed claims of the '087 patent and they were provided a chart of the infringement. Defendant has known of its infringement since at least that date as a result of the accusations of infringement in the letters. Defendant has therefore also known that the use of the '087 Accused Chargers by its customers infringed at least one claim of the '087 patent since at least the date they received the letters. Defendant was informed of its infringement of the '087 patent by way of the August 1, 2023, and April 13, 2024, letters sent to Defendant, including claim charts demonstrating Defendant's infringement. As a result of the letters, Defendant should have known that its actions constituted an unjustifiably high risk of infringement. Despite the letters and knowledge that the risk of infringement was either known or so obvious that it should have been known, Defendant continued its infringing actions.

51. Plaintiff has been damaged as a result of Defendant's infringing conduct. Defendant is thus liable to Plaintiff for damages in an amount that adequately compensates Plaintiff for Defendant's infringement of the '087 patent, *i.e.*, in an amount that by law cannot be less than a reasonable royalty for the use of the patented technology, together with interest and costs as fixed by this Court under 35 U.S.C. § 284.

VI. COUNT III
(PATENT INFRINGEMENT OF UNITED STATES PATENT NO. 10,951,042)

52. Upon information and belief, Defendant directly infringed claims 1, 5-6, 11,15-16 of the '042 patent (in Texas, and elsewhere in the United States), by making, using, selling, offering for sale and/or importing a product or power supply system comprising power circuitry configured to provide direct current power, such products including, but not limited to, the following: AT&T 10K Power Delivery Portable Battery with USB-C In/Out + USB-A Out (“’042 Accused Chargers”).

53. Claim 1 of the '042 patent states:

A portable electronic device comprising:

a rechargeable battery;

power circuitry configured to receive direct current and to charge the rechargeable battery; and

data circuitry configured to provide a first signal to a power supply and to receive a second signal from the power supply, the data circuitry and the power circuitry configured to be coupled via a connector to the power supply, the connector comprising a first conductor, a second conductor, a third conductor, and a fourth conductor, the connector configured to be detachably mated with an interface of the power supply to:

transfer, via the first conductor, the direct current from the power supply,

provide, via the second conductor, a ground reference from the power supply,

communicate, via the third conductor, the first signal from the data circuitry to the power supply, and

communicate, via the fourth conductor, the second signal from the power supply to the data circuitry;

wherein the second signal has a parameter level that is usable by the data circuitry in connection with control of charging the rechargeable battery based on the direct current received by the power circuitry.

(Ex. C at 11:2-25).

A. Infringement for Compliance with the Power Delivery Standard

54. Upon information and belief, Defendant directly infringed claims 1, 5-6, 11,15-16 of the '042 patent (in Texas, and elsewhere in the United States), by making, using, selling, offering for sale and/or importing a product or power supply system comprising power circuitry configured to provide direct current power, such products including: AT&T 10K Power Delivery Portable Battery with USB-C In/Out + USB-A Out which comply with Universal Serial Bus Power Delivery Specification, Revision 2.0 January 2017. (“‘042 Accused PD Chargers”).

55. Defendant made, used, sold, offered for sale and/or imported a portable electronic device, such as the '042 Accused PD Chargers, comprising a rechargeable battery. This element is met literally, or in the alternative, under the doctrine of equivalents. For example, Defendant provided '042 Accused PD Chargers. Each '042 Accused PD Charger includes a USB-C port with Power Delivery, through which the '042 Accused PD Chargers device can charge batteries of portable electronic devices using a full featured USB Type-C cable. The '042 Accused PD Chargers are configured to connect to charging devices through a full featured USB Type-C cable to receive DC power. Further, the USB-C ports of the '042 Accused PD Chargers are compliant with at least Universal Serial Bus Type-C Cable and Connector Specification, Release 1.0 August 2014 (along with other subsequent revisions of Type-C specification), and Universal Serial Bus Power Delivery Specification, Revision 1.0 January 2017.

[See all accessories](#)[Write a review](#)**AT&T 10K Power Delivery
Portable Battery with USB-C
In/Out + USB-A Out****Special offers (1)****Earn up to \$440 back**

AT&T Wireless customers enjoy an exclusive benefit with the AT&T Points Plus® Card from Citi. Terms apply.

[Learn how](#)**Color:** Black

Simultaneously charge two devices at the same time while on-the-go to help keep you fully charged throughout the day. The LED indicator lights signify the charging status and current battery life so you know exactly how much power you have left.

Features:

- Single USB-C port + single USB-A port outputs
- Compact design
- Four LED indicators show battery power level
- Charges two devices simultaneously
- Power delivery output rapidly charges premium Android and Apple devices
- Power Delivery input rapidly re-charges the portable battery
- Output: USB-C (20W): 5VDC/3A; 9VDC/2.22A; 12VDC/1.67A
- USB-A: fast charge 18W
- Maximum 20W
- Input: USB-C 18W PD
- UL approved battery cell
- 1-year limited warranty

(E.g., <https://www.att.com/buy/accessories/Chargers/att-10k-power-delivery-portable-battery-with-usb-c-in-out-plus-usb-a-out.html?q=usb%20c%20pd>).

56. On information and belief, Defendant provided a portable electronic device, such as the '042 Accused PD Chargers, comprising power circuitry configured to receive direct current and to charge the rechargeable battery. This element is met literally, or in the alternative, under the doctrine of equivalents. For example, to charge the rechargeable battery of a portable electronic device, a USB cable is connected to the USB power supply acting as a power supply. The other end of the USB cable is connected to the charging port of the portable electronic device and the power supply is plugged into a standard wall socket. Therefore, the portable electronic device comprises power circuitry to receive DC power from the power supply.

57. Defendant provided a portable electronic device, such as the ‘042 Accused PD Chargers, that comprises a data circuitry configured to provide a first signal to a power supply and to receive a second signal from the power supply. This element is met literally, or in the alternative, under the doctrine of equivalents. For example, the ‘042 Accused PD Chargers comprise data circuitry as described in the Universal Serial Bus Type-C Cable and Connector Specification and Universal Serial Bus Power Delivery Specification. The ‘042 Accused PD Chargers are configured to connect to power supplies through a USB cable. The USB cable has a connector of the type including but not limited to USB-C at one end to detachably mate with the charging port of a power supply. The connector comprises VBUS (“first conductor”), GND (“second conductor”), and two Configuration Channel conductors, *i.e.*, CC1/CC2 (“third conductor” / “fourth conductor”). The USB Type-C connector mating the USB Type-C charging port of the ‘042 Accused PD Chargers are designed to be used without regard to orientation. When an ‘042 Accused PD Charger is connected to a power supply through the full featured USB Type-C cable, the orientation of the connector to the power supply is detected first. The power supply detects the proper orientation of the connected USB Type-Cable by checking the voltage signal at the CC1 and CC2 pins. The values of the two resistors, R_p and R_d are fixed such that the voltage signal at one of the two CC pins (*i.e.*, CC1 and CC2) will be lower than the predetermined threshold value. The power supply determines which of the two CC pins are used as a configuration channel by detecting a voltage less than a certain threshold voltage at the CC pin in use. The CC pin used as a configuration channel is the “third conductor” and the voltage signal (“first signal”) received at one of the CC pin meeting the threshold requirement from the ‘042 Accused PD Charger connected via the full featured USB Type-Cable is determined by the voltage divider signal generated by the R_d resistor in the ‘042 Accused PD Charger with the R_p resistor in the power supply. The CC pin

that is not used as a configuration channel then becomes the Vconn conductor (“the fourth conductor”). The power supply connects to the full-featured USB Type-C cable that is electronically marked. To connect to an electronically marked USB Type-C cable, the power supply utilizes the Vconn pin. With the electronically marked USB Type-Cable, the CC pin not used as the configuration channel is used as the Vconn source. Upon providing the Vconn signal to the ‘042 Accused PD Charger, the power supply communicates the SOP/SOP’/SOP’’ (SOP*) packet with the ‘042 Accused PD Charger that is used to control the power delivery from the power supply to the ‘042 Accused PD Charger. The SOP* includes the SOP communication from the power supply to the ‘042 Accused PD Charger that is attached. The voltage signal at the Vconn pin sent from the power supply to the ‘042 Accused PD Charger is the “second signal” because the Vconn signal enables the SOP* communication that controls charging the battery in the ‘042 Accused PD Charger.

Table 3-4 USB Type-C Receptacle Interface Pin Assignments

Pin	Signal Name	Description	Mating Sequence	Pin	Signal Name	Description	Mating Sequence
A1	GND	Ground return	First	B12	GND	Ground return	First
A2	SSTXp1	Positive half of first SuperSpeed TX differential pair	Second	B11	SSRXp1	Positive half of first SuperSpeed RX differential pair	Second
A3	SSTXn1	Negative half of first SuperSpeed TX differential pair	Second	B10	SSRXn1	Negative half of first SuperSpeed RX differential pair	Second
A4	Vbus	Bus Power	First	B9	Vbus	Bus Power	First
A5	CC1	Configuration Channel	Second	B8	SBU2	Sideband Use (SBU)	Second
A6	Dp1	Positive half of the USB 2.0 differential pair - Position 1	Second	B7	Dn2	Negative half of the USB 2.0 differential pair - Position 2	Second
A7	Dn1	Negative half of the USB 2.0 differential pair - Position 1	Second	B6	Dp2	Positive half of the USB 2.0 differential pair - Position 2	Second
A8	SBU1	Sideband Use (SBU)	Second	B5	CC2	Configuration Channel	Second
A9	Vbus	Bus Power	First	B4	Vbus	Bus Power	First
A10	SSRXn2	Negative half of second SuperSpeed RX differential pair	Second	B3	SSTXn2	Negative half of second SuperSpeed TX differential pair	Second
A11	SSRXp2	Positive half of second SuperSpeed RX differential pair	Second	B2	SSTXp2	Positive half of second SuperSpeed TX differential pair	Second
A12	GND	Ground return	First	B1	GND	Ground return	First

(E.g., Universal Serial Bus Type-C Cable and Connector Specification Revision 1.0 August 2014, Page 49).

The USB Type-C receptacle, plug and cable designs are intended to support future USB functional extensions. As such, consideration was given to frequency scaling performance, pin-out arrangement and the configuration mechanisms when developing this solution. The definition of future USB functional extensions is not in the scope of this specification but rather will be provided in future releases of the base USB Specification, i.e., beyond the existing [USB 3.1 Specification](#).

Figure 2-1 illustrates the comprehensive functional signal plan for the USB Type-C receptacle, not all signals shown are required in all platforms or devices. As shown, the receptacle signal list functionally delivers both [USB 2.0](#) (D+ and D-) and [USB 3.1](#) (TX and RX pairs) data buses, USB power (VBUS) and ground (GND), [Configuration Channel](#) signals (CC1 and CC2), and two Sideband Use (SBU) signal pins. Multiple sets of USB data bus signal locations in this layout facilitate being able to functionally map the USB signals independent of plug orientation in the receptacle. For reference, the signal pins are labeled.

(E.g., Universal Serial Bus Type-C Cable and Connector Specification, Release 1.0 August 2014, Page 18).

Figure 2-1 USB Type-C Receptacle Interface (Front View)

A1	A2	A3	A4	A5	A6	A7	A8	A9	A10	A11	A12
GND	TX1+	TX1-	VBUS	CC1	D+	D-	SBU1	VBUS	RX2-	RX2+	GND
GND	RX1+	RX1-	VBUS	SBU2	D-	D+	CC2	VBUS	TX2-	TX2+	GND
B12	B11	B10	B9	B8	B7	B6	B5	B4	B3	B2	B1

(E.g., Universal Serial Bus Type-C Cable and Connector Specification Revision 1.0 August 2014, Page 18).

4.5.1.1 USB Data Bus Interface and USB Type-C Plug Flip-ability

Since the USB Type-C plug can be inserted in either right-side-up or upside-down position, the hosts and devices that support USB data bus functionality must operate on the signal pins that are actually connected end-to-end. In the case of USB 2.0, this is done by shorting together the two D+ signal pins and the two D- signal pins in the DFP and UFP receptacles. In the case of USB SuperSpeed signals, it requires the functional equivalent of a switch in both the DFP and UFP to appropriately route the SuperSpeed TX and RX signal pairs to the connected path through the cable.

(E.g., Universal Serial Bus Type-C Cable and Connector Specification Revision 1.0 August 2014, Page 104).

Figure 4-3 Logical Model for Data Bus Routing across USB Type-C-based Ports

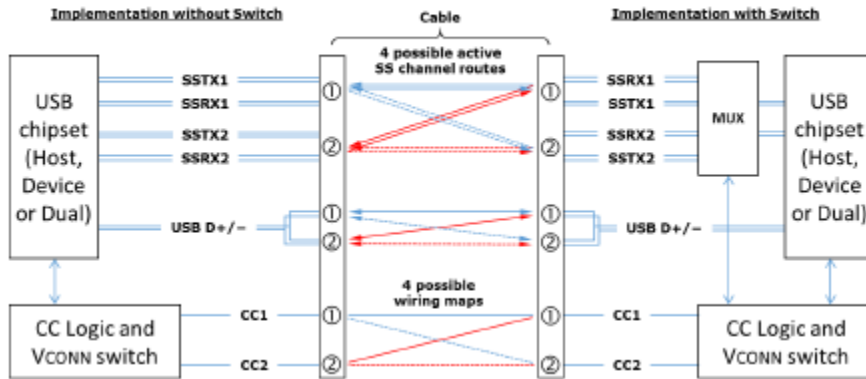

(E.g., Universal Serial Bus Type-C Cable and Connector Specification Revision 1.0 August 2014, Page 105).

4.5.1.2.1 Detecting a Valid DFP-to-UFP Connection

The general concept for setting up a valid connection between a DFP and UFP is based on being able to detect terminations residing in the product being attached.

To aid in defining the functional behavior of CC, a pull-up (R_p) and pull-down (R_d) termination model is used – actual implementation in hosts and devices may vary, for example, the pull-up termination could be replaced by a current source. Figure 4-5 and Figure 4-6 illustrates two models, the first based on a pull-up resistor in the DFP and the second replacing this with a current source.

Figure 4-5 Pull-Up/Pull-Down CC Model

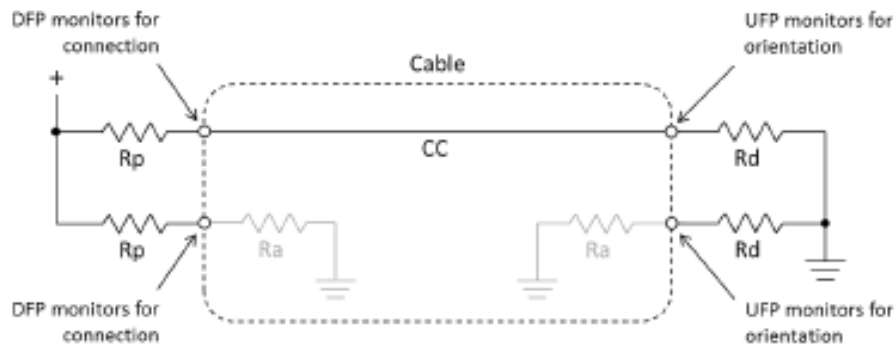

(E.g., Universal Serial Bus Type-C Cable and Connector Specification Revision 1.0 August

2014, Page 107).

Table 4-10 provides the values that shall be used for the DFP's R_p or current source. Other pull-up voltages shall be allowed if they remain less than 5.5 V and fall within the correct voltage ranges on the UFP side – see Table 4-18, Table 4-19 and Table 4-20. Note: when two DFPs are connected together, they may use different termination methods which could result in unexpected current flow.

Table 4-10 DFP CC Termination (R_p) Requirements

DFP Advertisement	Current Source to 1.7 – 5.5 V	Resistor pull-up to 4.75 – 5.5 V	Resistor pull-up to 3.3 V ± 5%
Default USB Power	80 μ A ± 20%	56 k Ω ± 20%	36 k Ω ± 20%
1.5 A @ 5 V	180 μ A ± 8%	22 k Ω ± 5%	12 k Ω ± 5%
3.0 A @ 5 V	330 μ A ± 8%	10 k Ω ± 5%	4.7 k Ω ± 5%

The UFP may find it convenient to implement R_d in multiple ways simultaneously (a wide range R_d when unpowered and a trimmed R_d when powered). Transitions between R_d implementations that do not exceed $t_{CCDebounce}$ shall not be interpreted as exceeding the wider R_d range. Table 4-11 provides the methods and values that shall be used for the UFP's R_d implementation.

Table 4-11 UFP CC Termination (R_d) Requirements

R_d Implementation	Nominal value	Can detect power capability?	Max voltage on pin
± 20% voltage clamp ¹	1.1 V	No	1.32 V
± 20% resistor to GND	5.1 k Ω	No	2.18 V
± 10% resistor to GND	5.1 k Ω	Yes	2.04 V

Note:

1. The clamp implementation inhibits *USB PD* communication although the system can start with the clamp and transition to the resistor once it is able to do *USB PD*.

(E.g., Universal Serial Bus Type-C Cable and Connector Specification Revision 1.0 August 2014, Pages 149-150).

2.5 VCONN

Once the connection between host and device is established, the CC pin (CC1 or CC2) in the receptacle that is not connected via the CC wire through the standard cable is repurposed to source VCONN to power circuits in the plug needed to implement Electronically Marked Cables (see Section 4.9). Initially, the DFP sources VCONN and the source may be swapped using *USB PD* VCONN_Swap.

Electronically marked cables may use VBUS instead of VCONN as VBUS is available across the cable. VCONN functionally differs from VBUS in that it is isolated from the other end of the cable. VCONN is independent of VBUS and, unlike VBUS which can use *USB PD* to support higher voltages, VCONN voltage is fixed at 5 V.

(E.g., Universal Serial Bus Type-C Cable and Connector Specification Revision 1.0 August

2014, Page 23).

4.9 Electronically Marked Cables

All USB Full-Featured Type-C cables shall be electronically marked. USB 2.0 Type-C cables may be electronically marked.

Electronically marked cables shall support USB Power Delivery Structured VDM Discover Identity command directed to SOP'. This provides a method to determine the characteristics of the cable, e.g. its current carrying capability, its performance, vendor identification, etc. This may be referred to as the USB Type-C Cable ID function.

Prior to an explicit USB PD contract, a Charging UFP is allowed to use SOP' to discover the cable's identity. After an explicit USB PD contract has been negotiated, only the DFP shall communicate with SOP'.

An electronically marked cable incorporates electronics that require VCONN, although VBUS or another source may be used. Electronically marked cables that do not incorporate data bus signal conditioning circuits shall consume no more than 70 mW from VCONN. During USB suspend, electronically marked cables shall not draw more than 7.5 mA from VCONN, see Section 4.6.1.2.

(E.g., Universal Serial Bus Type-C Cable and Connector Specification Revision 1.0 August 2014, Page 147).

Figure 4-34 Electronically Marked Cable with VCONN connected through the cable

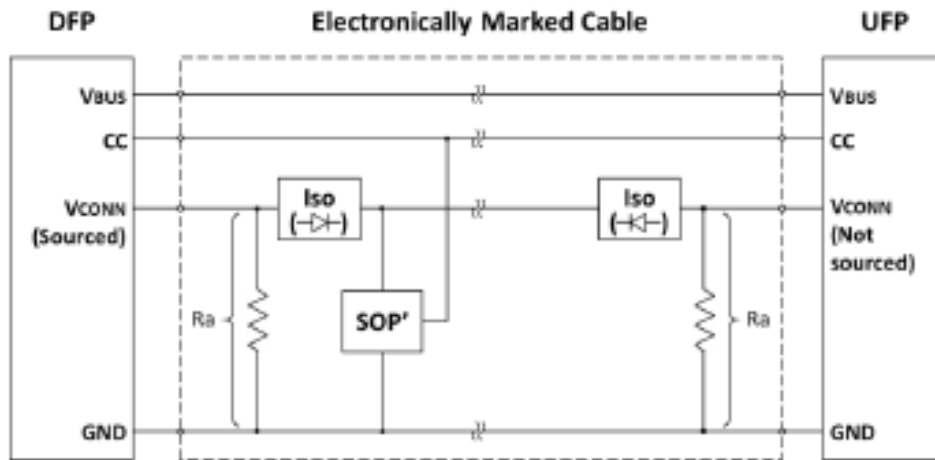

(E.g., Universal Serial Bus Type-C Cable and Connector Specification Revision 1.0 August 2014, Page 148).

Figure 4-35 Electronically Marked Cable with SOP' at both ends

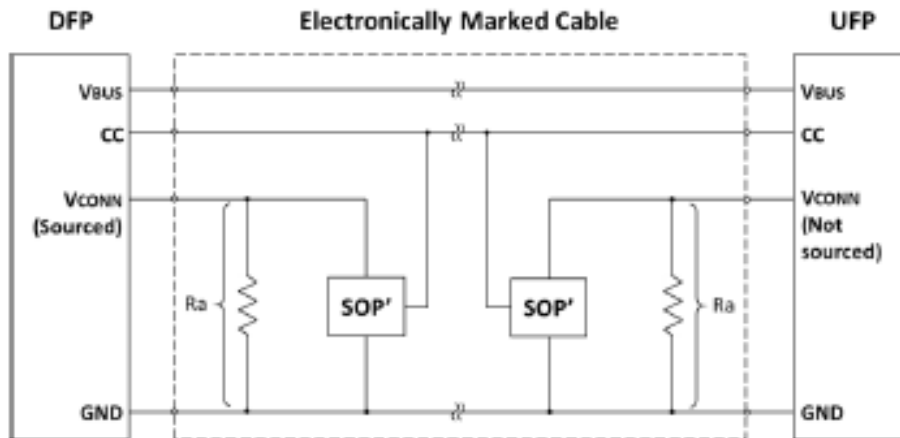

(E.g., Universal Serial Bus Type-C Cable and Connector Specification Revision 1.0 August 2014, Page 147).

All SOP* Communications take place over a single wire (CC). This means that the SOP* Communication periods must be coordinated to prevent important communication from being blocked. For a product which does not recognize SOP/SOP' or SOP'' Packets, this will look like a non-idle channel, leading to missed packets and retries. Communications between the Port Partners take precedence meaning that communications with the Cable Plug can be interrupted but will not lead to a Soft or Hard Reset.

When no Contract or an Implicit Contract is in place (e.g., after a Power Role Swap or Fast Role Swap) only the Source port that is supplying VCONN is allowed to send packets to a Cable Plug (SOP') and is allowed to respond to packets from the Cable Plug (SOP') with a GoodCRC in order to discover the Cable Plug's characteristics (see Figure 2-2). During this phase all communication with the Cable Plug is initiated and controlled by the Source which acts to prevent conflicts between SOP and SOP' Packets. The Sink does not communicate with the Cable Plug and Discards any SOP' Packets received.

When an Explicit Contract is in place the VCONN Source (either the DFP or the UFP) can communicate with the Cable Plug(s) using SOP'/SOP'' Packets (see Figure 2-2). During this phase all communication with the Cable Plug is initiated and controlled by the VCONN Source which acts to prevent conflicts between SOP* Packets. The Port that is not the VCONN Source does not communicate with the Cable Plug and does not recognize any SOP'/SOP'' Packets received. Only the DFP, when acting as a VCONN Source, is allowed to send SOP* in order to control the entry and exiting of Modes and to manage Modal Operation.

Figure 2-2 Example SOP' Communication between VCONN Source and Cable Plug(s)

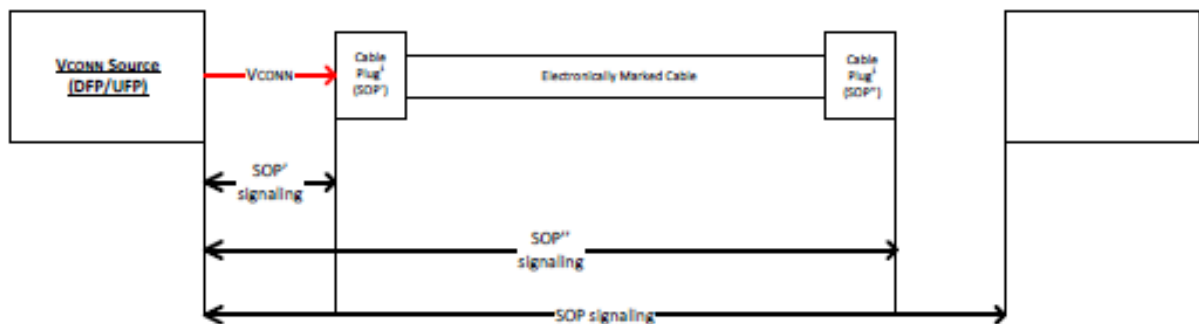

(E.g., Universal Serial Bus Power Delivery Specification Revision 3.1, April 2022, Page 7).

Term	Description
Sink Directed Charge	A charging scheme whereby the Sink connects the Source to its battery through safety and other circuitry. When the SPR PPS Current Limit feature is activated, the Source automatically controls its output current by adjusting its output Voltage.
Soft Reset	A process that resets the PD communications engine to its default state.
SOP Communication	Communication using SOP Packets also implies that a Message sequence is being followed.
SOP Packet	Any Power Delivery Packet which starts with an <i>SOP</i> .
SOP* Communication	Communication with a Cable Plug using SOP* Packets, also implies a Message sequence is being followed.
SOP* Packet	A term referring to any Power Delivery Packet starting with either <i>SOP</i> , <i>SOP*</i> or <i>SOP''</i> .
SOP' Communication	Communication with a Cable Plug using SOP' Packets, also implies that a Message sequence is being followed.
SOP' Packet	Any Power Delivery Packet which starts with an <i>SOP'</i> used to communicate with a Cable Plug.
SOP'' Communication	Communication with a Cable Plug using SOP'' Packets, also implies that a Message sequence is being followed.
SOP'' Packet	Any Power Delivery Packet which starts with an <i>SOP''</i> used to communicate with a Cable Plug when SOP' Packets are being used to communicate with the other Cable Plug.

(E.g., Universal Serial Bus Power Delivery Specification Revision 3.1, April 2022, Page 68).

58. Defendant provided a portable electronic device, such as the ‘042 Accused PD Chargers, to transfer, via the first conductor, the direct current from the power supply, provide, via the second conductor, a ground reference from the power supply, communicate, via the third conductor, the first signal from the data circuitry to the power supply, and communicate, via the fourth conductor, the second signal from the power supply to the data circuitry. This element is met literally, or in the alternative, under the doctrine of equivalents. For example, the VBUS pin is the voltage line that provides DC power from the power supply to the ‘042 Accused PD Charger. For example, the GND pin provides a ground reference from the power supply to the ‘042 Accused PD Charger. When an ‘042 Accused PD Charger is connected to a power supply through a USB Type-C cable, the orientation of the connector to the power supply is detected first. The power supply detects the proper orientation of the connected USB Type-Cable by checking the voltage signal at the CC1 and CC2 pins. The values of the two resistors, Rp and Rd are fixed such that the voltage signal at one of the two CC pins (*i.e.*, CC1 and CC2) will be lower than the predetermined

threshold value. The power supply determines which of the two CC pins are used as the configuration channel by detecting a voltage less than a certain threshold voltage at the CC pin in use. The CC pin used as the configuration channel is the “third conductor” and the voltage signal received at one of the CC pins meeting the threshold requirement (“first signal”) from the ‘042 Accused PD Charger connected via the full featured USB Type-Cable is determined by the voltage divider signal generated by the R_d resistor in the ‘042 Accused PD Charger with the R_p resistor in the power supply. The CC pin that is not used as a configuration channel then becomes the Vconn conductor (“the fourth conductor”). The power supply connects to the full-featured USB Type-C cable that is electronically marked. To connect to an electronically marked USB Type-C cable, the power supply utilizes the Vconn pin. With the electronically marked USB Type-Cable, the CC pin not used for the configuration is used as the Vconn source. Upon providing the Vconn source, the power supply communicates the SOP* packets with the ‘042 Accused PD Charger, which control charging of the battery in the ‘042 Accused PD Charger. The SOP* includes the SOP communication from the power supply to the ‘042 Accused PD Charger that is attached. The voltage signal sent at the Vconn pin from the power supply to the ‘042 Accused PD Charger is the “second signal” because this voltage signal enables the SOP* communication that controls charging the battery in the ‘042 Accused PD Charger.

Figure 2-1 illustrates the comprehensive functional signal plan for the USB Type-C receptacle, not all signals shown are required in all platforms or devices. As shown, the receptacle signal list functionally delivers both [USB 2.0](#) (D+ and D-) and [USB 3.1](#) (TX and RX pairs) data buses, [USB power \(VBUS\) and ground \(GND\)](#), [Configuration Channel](#) signals (CC1 and CC2), and two Sideband Use (SBU) signal pins. Multiple sets of USB data bus signal locations in this layout facilitate being able to functionally map the USB signals independent of plug orientation in the receptacle. For reference, the signal pins are labeled.

Figure 2-1 USB Type-C Receptacle Interface (Front View)

A1	A2	A3	A4	A5	A6	A7	A8	A9	A10	A11	A12
GND	TX1+	TX1-	VBUS	CC1	D+	D-	SBU1	VBUS	RX2-	RX2+	GND
GND	RX1+	RX1-	VBUS	SBU2	D-	D+	CC2	VBUS	TX2-	TX2+	GND
B12	B11	B10	B9	B8	B7	B6	B5	B4	B3	B2	B1

(E.g., Universal Serial Bus Type-C Cable and Connector Specification, Release 1.0 August 2014, Page 18).

2.4 VBUS

VBUS provides a path to deliver power between a host and a device, and between a charger and a host/device. A simplified high-current supply capability is defined for hosts and chargers that optionally support current levels beyond the [USB 2.0](#) and [USB 3.1](#) specifications. The [USB Power Delivery Specification](#) is supported.

Table 2-1 summarizes the power supply options available from the perspective of a device with the USB Type-C connector. Not all options will be available to the device from all host

(E.g., Universal Serial Bus Type-C Cable and Connector Specification Revision 1.0 August 2014, Page 22).

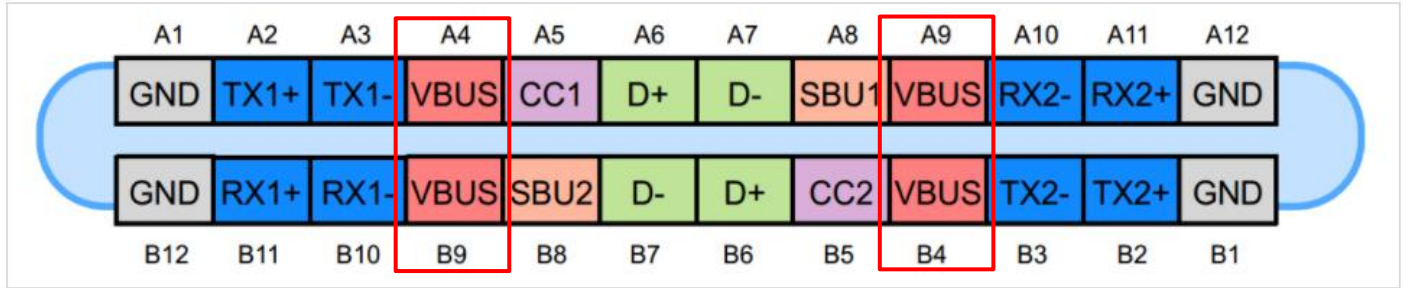

Figure 1. The USB Type-C receptacle. Image courtesy of Microchip.

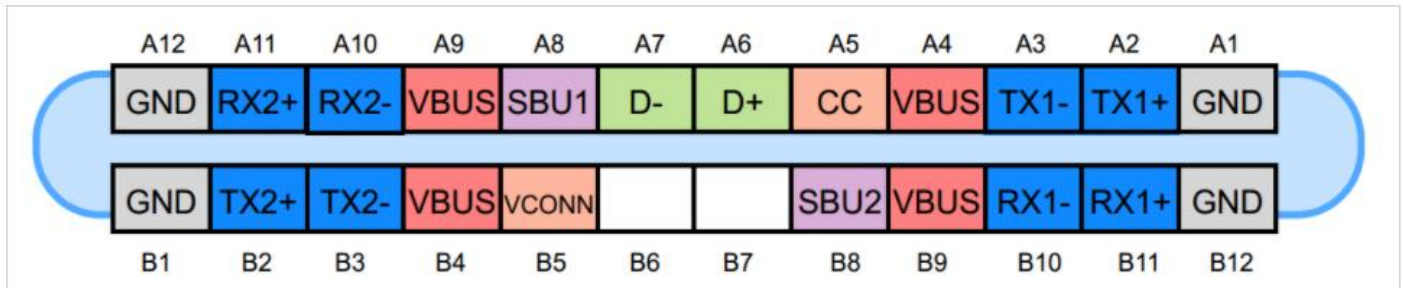

Figure 2. The USB Type-C plug. Image courtesy of Microchip.

(E.g., <https://www.allaboutcircuits.com/technical-articles/introduction-to-usb-type-c-which-pins-power-delivery-data-transfer/>).

2.3.1 DFP-to-UFP Attach/Detach Detection

Initially, DFP-to-UFP attach is detected by a host or hub port (DFP) when one of the CC pins at its USB Type-C receptacle senses a specified resistance to GND. Subsequently, DFP-to-UFP detach is detected when the CC pin that was terminated at its USB Type-C receptacle is no longer terminated to GND.

Power is not applied to the USB Type-C host or hub receptacle (VBUS or VCONN) until the DFP detects the presence of an attached device (UFP) port. When a DFP-to-UFP attach is detected, the DFP is expected to enable power to the receptacle and proceed to normal USB operation with the attached device. When a DFP-to-UFP detach is detected, the port sourcing VBUS removes power.

(E.g., Universal Serial Bus Type-C Cable and Connector Specification, Release 1.0 August 2014, Page 21).

Table 3-4 USB Type-C Receptacle Interface Pin Assignments

Pin	Signal Name	Description	Mating Sequence	Pin	Signal Name	Description	Mating Sequence
A1	GND	Ground return	First	B12	GND	Ground return	First

(E.g., Universal Serial Bus Type-C Cable and Connector Specification Revision 1.0 August 2014, Page 49).

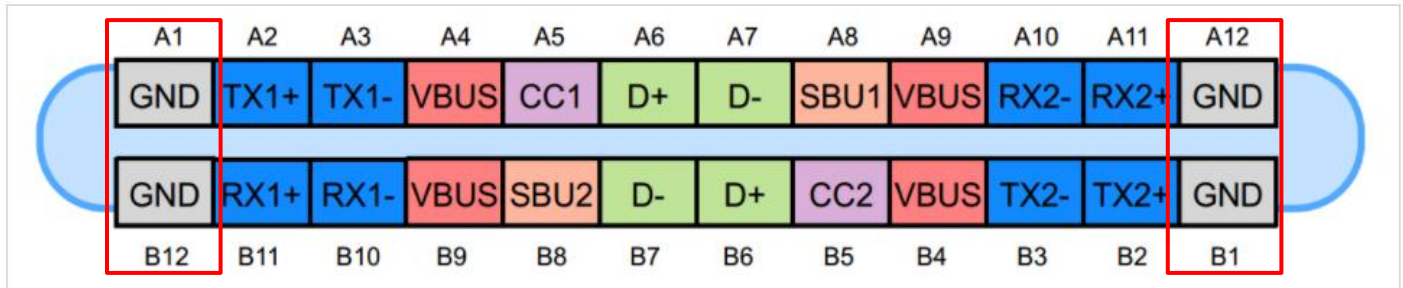

Figure 1. The USB Type-C receptacle. Image courtesy of *Microchip*.

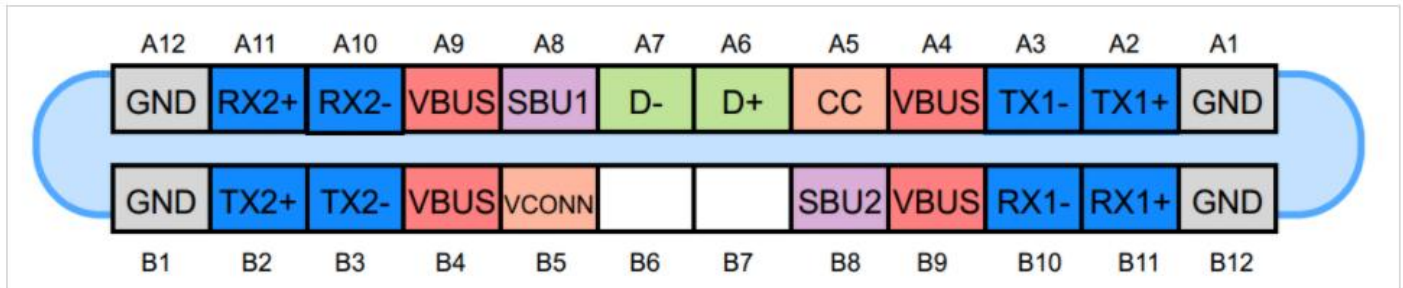

Figure 2. The USB Type-C plug. Image courtesy of *Microchip*.

(E.g., <https://www.allaboutcircuits.com/technical-articles/introduction-to-usb-type-c-which-pins-power-delivery-data-transfer/>).

4.5.1.2.1 Detecting a Valid DFP-to-UFP Connection

The general concept for setting up a valid connection between a DFP and UFP is based on being able to detect terminations residing in the product being attached.

To aid in defining the functional behavior of CC, a pull-up (R_p) and pull-down (R_d) termination model is used – actual implementation in hosts and devices may vary, for example, the pull-up termination could be replaced by a current source. Figure 4-5 and Figure 4-6 illustrates two models, the first based on a pull-up resistor in the DFP and the second replacing this with a current source.

Figure 4-5 Pull-Up/Pull-Down CC Model

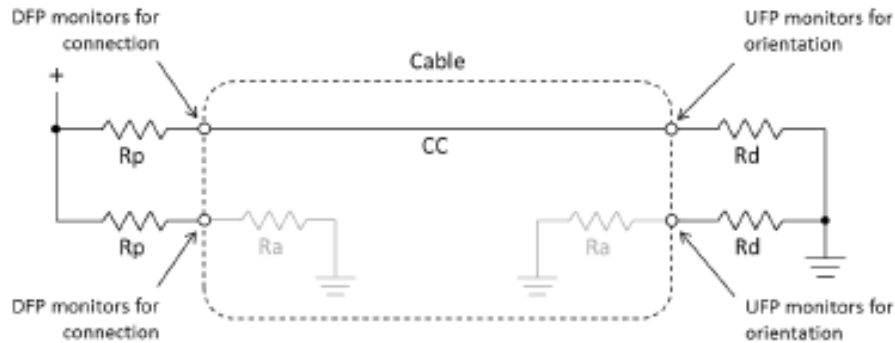

(E.g., Universal Serial Bus Type-C Cable and Connector Specification Revision 1.0 August 2014, Page107).

Table 4-10 provides the values that shall be used for the DFP's R_p or current source. Other pull-up voltages shall be allowed if they remain less than 5.5 V and fall within the correct voltage ranges on the UFP side – see Table 4-18, Table 4-19 and Table 4-20. Note: when two DFPs are connected together, they may use different termination methods which could result in unexpected current flow.

Table 4-10 DFP CC Termination (R_p) Requirements

DFP Advertisement	Current Source to 1.7 - 5.5 V	Resistor pull-up to 4.75 - 5.5 V	Resistor pull-up to 3.3 V ± 5%
Default USB Power	80 μ A ± 20%	56 k Ω ± 20%	36 k Ω ± 20%
1.5 A @ 5 V	180 μ A ± 8%	22 k Ω ± 5%	12 k Ω ± 5%
3.0 A @ 5 V	330 μ A ± 8%	10 k Ω ± 5%	4.7 k Ω ± 5%

The UFP may find it convenient to implement R_d in multiple ways simultaneously (a wide range R_d when unpowered and a trimmed R_d when powered). Transitions between R_d implementations that do not exceed $t_{CCDebounce}$ shall not be interpreted as exceeding the wider R_d range. Table 4-11 provides the methods and values that shall be used for the UFP's R_d implementation.

Table 4-11 UFP CC Termination (Rd) Requirements

Rd Implementation	Nominal value	Can detect power capability?	Max voltage on pin
± 20% voltage clamp ¹	1.1 V	No	1.32 V
± 20% resistor to GND	5.1 kΩ	No	2.18 V
± 10% resistor to GND	5.1 kΩ	Yes	2.04 V

Note:

1. The clamp implementation inhibits [USB PD](#) communication although the system can start with the clamp and transition to the resistor once it is able to do [USB PD](#).

(E.g., Universal Serial Bus Type-C Cable and Connector Specification Revision 1.0 August 2014, Pages 149-150).

2.5 VCONN

Once the connection between host and device is established, the CC pin (CC1 or CC2) in the receptacle that is not connected via the CC wire through the standard cable is repurposed to source VCONN to power circuits in the plug needed to implement Electronically Marked Cables (see Section 4.9). Initially, the DFP sources VCONN and the source may be swapped using [USB PD](#) VCONN_Swap.

Electronically marked cables may use VBUS instead of VCONN as VBUS is available across the cable. VCONN functionally differs from VBUS in that it is isolated from the other end of the cable. VCONN is independent of VBUS and, unlike VBUS which can use [USB PD](#) to support higher voltages, VCONN voltage is fixed at 5 V.

(E.g., Universal Serial Bus Type-C Cable and Connector Specification Revision 1.0 August 2014, Page 23).

4.9 Electronically Marked Cables

All USB Full-Featured Type-C cables shall be electronically marked. USB 2.0 Type-C cables may be electronically marked.

Electronically marked cables shall support [USB Power Delivery](#) Structured VDM Discover Identity command directed to SOP'. This provides a method to determine the characteristics of the cable, e.g. its current carrying capability, its performance, vendor identification, etc. This may be referred to as the USB Type-C Cable ID function.

Prior to an explicit [USB PD](#) contract, a Charging UFP is allowed to use SOP' to discover the cable's identity. After an explicit [USB PD](#) contract has been negotiated, only the DFP shall communicate with SOP'.

An electronically marked cable incorporates electronics that require VCONN, although VBUS or another source may be used. Electronically marked cables that do not incorporate data bus signal conditioning circuits shall consume no more than 70 mW from VCONN. During USB suspend, electronically marked cables shall not draw more than 7.5 mA from VCONN, see Section 4.6.1.2.

(E.g., Universal Serial Bus Type-C Cable and Connector Specification Revision 1.0 August 2014, Page 147).

Figure 4-34 Electronically Marked Cable with VCONN connected through the cable

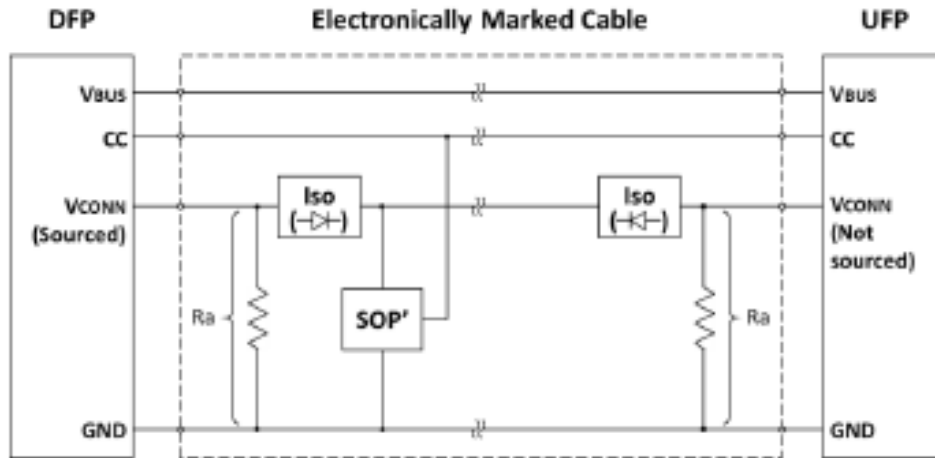

(E.g., Universal Serial Bus Type-C Cable and Connector Specification Revision 1.0 August 2014, Page 148).

Figure 4-35 Electronically Marked Cable with SOP' at both ends

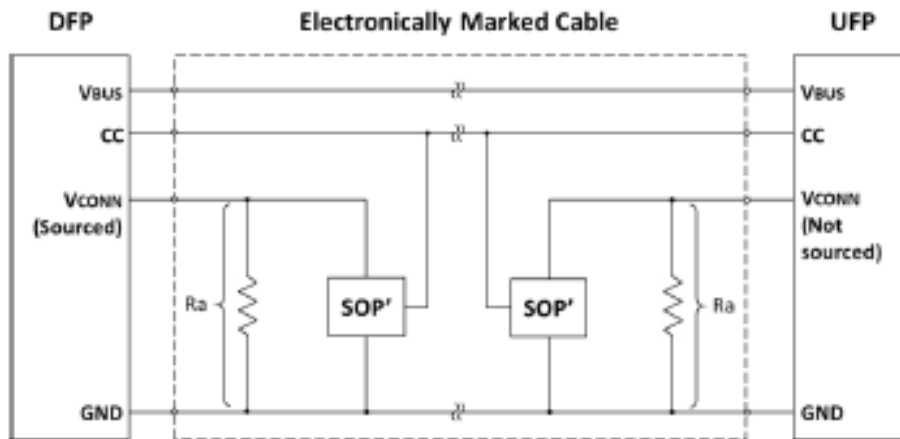

(E.g., Universal Serial Bus Type-C Cable and Connector Specification Revision 1.0 August 2014, Page 147).

All SOP* Communications take place over a single wire (CC). This means that the SOP* Communication periods must be coordinated to prevent important communication from being blocked. For a product which does not recognize SOP/SOP' or SOP'' Packets, this will look like a non-idle channel, leading to missed packets and retries. Communications between the Port Partners take precedence meaning that communications with the Cable Plug can be interrupted but will not lead to a Soft or Hard Reset.

When no Contract or an Implicit Contract is in place (e.g., after a Power Role Swap or Fast Role Swap) only the Source port that is supplying VCONN is allowed to send packets to a Cable Plug (SOP') and is allowed to respond to packets from the Cable Plug (SOP') with a GoodCRC in order to discover the Cable Plug's characteristics (see Figure 2-2). During this phase all communication with the Cable Plug is initiated and controlled by the Source which acts to prevent conflicts between SOP and SOP' Packets. The Sink does not communicate with the Cable Plug and Discards any SOP' Packets received.

When an Explicit Contract is in place the VCONN Source (either the DFP or the UFP) can communicate with the Cable Plug(s) using SOP'/SOP'' Packets (see Figure 2-2). During this phase all communication with the Cable Plug is initiated and controlled by the VCONN Source which acts to prevent conflicts between SOP* Packets. The Port that is not the VCONN Source does not communicate with the Cable Plug and does not recognize any SOP'/SOP'' Packets received. Only the DFP, when acting as a VCONN Source, is allowed to send SOP* in order to control the entry and exiting of Modes and to manage Modal Operation.

Figure 2-2 Example SOP' Communication between VCONN Source and Cable Plug(s)

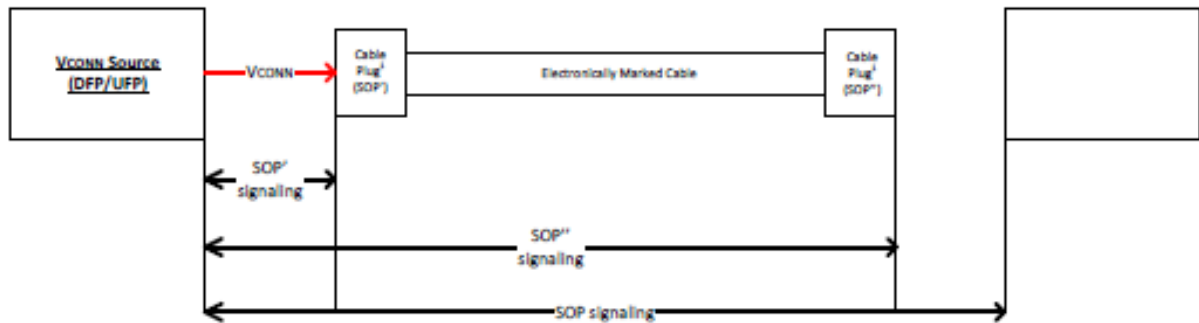

(E.g., Universal Serial Bus Power Delivery Specification Revision 3.1, April 2022, Page 7).

Term	Description
Sink Directed Charge	A charging scheme whereby the Sink connects the Source to its battery through safety and other circuitry. When the SPR PPS Current Limit feature is activated, the Source automatically controls its output current by adjusting its output Voltage.
Soft Reset	A process that resets the PD communications engine to its default state.
SOP Communication	Communication using SOP Packets also implies that a Message sequence is being followed.
SOP Packet	Any Power Delivery Packet which starts with an <i>SOP</i> .
SOP* Communication	Communication with a Cable Plug using SOP* Packets, also implies a Message sequence is being followed.
SOP* Packet	A term referring to any Power Delivery Packet starting with either <i>SOP</i> , <i>SOP'</i> or <i>SOP''</i> .
SOP' Communication	Communication with a Cable Plug using SOP' Packets, also implies that a Message sequence is being followed.
SOP' Packet	Any Power Delivery Packet which starts with an <i>SOP'</i> used to communicate with a Cable Plug.
SOP'' Communication	Communication with a Cable Plug using SOP'' Packets, also implies that a Message sequence is being followed.
SOP'' Packet	Any Power Delivery Packet which starts with an <i>SOP''</i> used to communicate with a Cable Plug when SOP' Packets are being used to communicate with the other Cable Plug.

(E.g., Universal Serial Bus Power Delivery Specification Revision 3.1, April 2022, Page 68).

59. Defendant provided a portable electronic device, such as the ‘042 Accused PD Chargers, in which the second signal has a parameter level that is usable by the data circuitry in connection with control of charging the rechargeable battery based on the direct current received by the power circuitry. This element is met literally, or in the alternative, under the doctrine of equivalents. As explained above, a voltage signal meeting the specified threshold value, *i.e.*, the “first signal,” is detected at the CC pin used as the configuration channel. In coordination with this voltage signal, the second signal, *i.e.*, another voltage signal from the Vconn pin is sent from the power supply to the ‘042 Accused PD Charger, which enables the SOP* communication that controls charging a rechargeable battery of the ‘042 Accused PD Charger.

2.5.3 SOP Communication

SOP Communication is used for Port-to-Port communication between the Source and the Sink. SOP Communication is recognized by both Port Partners but not by any intervening Cable Plugs. SOP Communication takes priority over other SOP* Communications since it is critical to complete power related operations as soon as possible. Message sequences relating to power are also allowed to interrupt other sequences to ensure that negotiation and control of power is given priority on the bus.

(E.g., Universal Serial Bus Power Delivery Specification Revision 3.1, April 2022, Page 75).

6.4.1.1 Use of the Capabilities Message

6.4.1.1.1 Use by Sources

Sources send a *Source_Capabilities* Message (see Section 6.4.1) either as part of advertising Port capabilities, or in response to a *Get_Source_Cap* Message.

Following a Hard Reset, a power-on event or plug insertion event, a Source Port *shall* send a *Source_Capabilities* Message after every *SourceCapabilityTimer* timeout as an Advertisement that *shall* be interpreted by the Sink Port on Attachment. The Source *shall* continue sending a minimum of *nCapsCount* *Source_Capabilities* Messages until a *GoodCRC* Message is received.

(E.g., Universal Serial Bus Power Delivery Specification Revision 3.1, April 2022, Page 146).

B. Indirect Infringement

60. Upon information and belief, Defendant was indirectly infringing by way of inducing infringement and contributing to the infringement of the asserted claims of the ‘042 patent in the State of Texas, in this District, and elsewhere in the United States, by providing the

'042 Accused Chargers for use as described above by Defendant's customers. Defendant advertised, offered for sale, and/or sold the '042 Accused Chargers (and continues to advertise, offer to sell, and sell) to its customers for use in a manner that Defendant knew infringed at least one claim of the '042 patent. For example, Defendant advertised and sold the '042 Accused Chargers. In addition, Defendant sold and offered for sale the following additional devices that are advertised as charging batteries and satisfy all limitations of the claim with the exception for the rechargeable battery: AT&T Multi Port 72W Power Delivery Power Hub (USB-C + USB-A); AT&T Dual Port 32W /Power Delivery Bullet Car Charger (USB-C + USB-A); AT&T Dual Port 40W Power Delivery Bullet Car Charger (USB-C + USB-C); AT&T Dual Port 32W Power Delivery Wall Block (USB-C + USB-A); AT&T Captive Cable Power Delivery Car Charger 40W with USB-C Port (USB-C); and AT&T Single Port 30W Power Delivery Wall Block USB-C (collectively "Additional '042 Accused Chargers"). Defendant is a direct and indirect infringer, and its customers using the '042 Accused Chargers and Additional '042 Accused Chargers are direct infringers. Defendant had actual knowledge of the '042 patent at least as early as when they received letters from Plaintiff sent on August 1, 2023, and April 13, 2024, asserting that the '042 Accused Chargers and Additional '042 Accused Chargers infringed claims of the '042 patent and they were provided a claim chart that provided evidence of the infringement. Defendant has known of its infringement since at least that date as a result of the accusations of infringement in the notice letters. Defendant has therefore also known that the use of the '042 Accused Chargers and Additional '042 Accused Chargers by its customers infringed at least one claim of the '042 patent since at least the date they received the letters.

61. On information and belief, since Defendant became aware of the '042 patent and of the infringement through advertising and offering for sale the '042 Accused Chargers and

Additional '042 Accused Chargers for use by its customers, Defendant was committing the act of inducing infringement by specifically intending to induce infringement by providing the '042 Accused Chargers and Additional '042 Accused Chargers to its customers and by aiding and abetting its use in a manner known to infringe by Defendant. Since Defendant became aware of the infringing use of the '042 Accused Chargers and Additional '042 Accused Chargers, Defendant knew that the use of the '042 Accused Chargers and Additional '042 Accused Chargers by its customers as a charger with a portable electronic device (including a rechargeable battery) constituted direct patent infringement. Despite this knowledge, Defendant continued to encourage and induce its customers to use the '042 Accused Chargers and Additional '042 Accused Chargers to infringe as described above and provided instructions for using the '042 Accused Chargers and Additional '042 Accused Chargers to infringe, including through advertisements. Defendant therefore knowingly induced infringement and specifically intended to encourage and induce the infringement of the '042 patent by its customers.

62. On information and belief, since Defendant became aware of the acts of infringement at least as of the date of receipt of the notice letters, Defendant was committing the act of contributory infringement by intending to provide the '042 Accused Chargers and Additional '042 Accused Chargers to its customers knowing that such devices are a material part of the claimed invention, knowing that its use was made and adapted for infringement of the '042 patent as described above, and further knowing that the accused aspect of the '042 Accused Chargers and Additional '042 Accused Chargers described above is not a staple article or commodity of commerce suitable for substantially noninfringing use. As described above, Defendant was aware that all material claim limitations are satisfied by the use and implementation of the '042 Accused Chargers and Additional '042 Accused Chargers by Defendant's customers in the manner

described above yet continued to provide the '042 Accused Chargers and Additional '042 Accused Chargers to its customers knowing that it is a material part of the claimed invention. As described above, since learning of the infringement, Defendant knew that the use and implementation of the '042 Accused Chargers and Additional '042 Accused Chargers by its customers was made and adapted for infringement of the '042 patent. A new act of direct infringement occurred each time a customer implemented and/or used the '042 Accused Chargers and Additional '042 Accused Chargers in the manner described above. After Defendant became aware that the use of the '042 Accused Chargers and Additional '042 Accused Chargers infringe at least one claim of the '042 patent, Defendant knew that each such new use was made and adapted for infringement of at least one claim of the '042 patent and Defendant continued to advertise and provide the '042 Accused Chargers and Additional '042 Accused Chargers for such infringing activities. Furthermore, as described more fully above, the '042 Accused Chargers and Additional '042 Accused Chargers have functionality designed for use in a system in the manner described above and is therefore not a staple article or commodity of commerce suitable for substantially noninfringing use.

63. Upon information and belief, Defendant was willfully infringing the asserted claims of the '042 patent in Texas, in this District, and elsewhere in the United States. Defendant had actual knowledge of the '042 patent at least as early as when they received letters from Plaintiff sent on August 1, 2023, and April 13, 2024, asserting that the '042 Accused Chargers and Additional '042 Accused Chargers infringed claims of the '042 patent and they were provided a chart of the infringement. Defendant has known of its infringement since at least that date as a result of the accusations of infringement in the letters. Defendant has therefore also known that the use of the '042 Accused Chargers and Additional '042 Accused Chargers by its customers infringed at least one claim of the '042 patent since at least the date they received the letters.

Defendant was informed of its infringement of the '042 patent by way of the August 1, 2023, and April 13, 2024, letters sent to Defendant, including claim charts demonstrating Defendant's infringement. As a result of the letters, Defendant should have known that its actions constituted an unjustifiably high risk of infringement. Despite the letters and knowledge that the risk of infringement was either known or so obvious that it should have been known, Defendant continued its infringing actions.

64. Plaintiff has been damaged as a result of Defendant's infringing conduct. Defendant is thus liable to Plaintiff for damages in an amount that adequately compensates Plaintiff for Defendant's infringement of the '042 patent, *i.e.*, in an amount that by law cannot be less than a reasonable royalty for the use of the patented technology, together with interest and costs as fixed by this Court under 35 U.S.C. § 284.

65. On information and belief, to the extent marking is required, Comarco complied with all marking requirements.

VII. JURY DEMAND

Plaintiff, under Rule 38 of the Federal Rules of Civil Procedure, requests a trial by jury of any issues so triable by right.

VIII. PRAYER FOR RELIEF

WHEREFORE, Plaintiff respectfully requests that the Court find in its favor and against Defendant, and that the Court grant Plaintiff the following relief:

- a. Judgment that one or more claims of United States Patent No. 9,413,187 have been directly and indirectly infringed, either literally and/or under the doctrine of equivalents, by Defendant;
- b. Judgment that one or more claims of United States Patent No. 10,855,087 have been directly and indirectly infringed, either literally and/or under the doctrine of equivalents, by Defendant;

- c. Judgment that one or more claims of United States Patent No. 10,951,042 have been directly and indirectly infringed, either literally and/or under the doctrine of equivalents, by Defendant;
- d. Judgment that Defendant account for and pay to Plaintiff all damages to and costs incurred by Plaintiff because of Defendant's infringing activities and other conduct complained of herein, and an accounting of all infringements and damages not presented at trial;
- e. Adjudging that Defendant's infringement of United States Patent Nos. 9,413,187, 10,855,087, and 10,951,042 was willful and trebling all damages awarded to Comarco for such infringement pursuant to 35 U.S.C. § 284;
- f. That Plaintiff be granted pre-judgment and post-judgment interest on the damages caused by Defendant's infringing activities and other conduct complained of herein; and
- g. That Plaintiff be granted such other and further relief as the Court may deem just and proper under the circumstances.

February 13, 2025

DIRECTION IP LAW

/s/ Steven G. Kalberg

David R. Bennett (IL Bar No. 6244214)

Steven G. Kalberg (IL Bar No. 6336131)

(Admitted to the U.S. Dist. Ct. for the E.D. Texas)

Direction IP Law

P.O. Box 14184

Chicago, IL 60614-0184

(312) 291-1667

dbennett@directionip.com

skalberg@directionip.com

Attorney for Plaintiff

Comarco Wireless Systems LLC